



Operation Manual

PRODUCT NAME

Liquid Dispense Pump (Solenoid Type)

MODEL / Series / Product Number

LSP series

SMC Corporation

Contents

1. Safety Instructions	P2
2. Specific Product Precautions	P3~5
3. Feature / Application Example	P6
4. How To Order / Specifications	P7
5. Construction	P8
6. Dimensions	P9~10
7. Countermeasures	P11~13

Safety Instructions

These safety instructions are intended to prevent hazardous situations and/or equipment damage. These instructions indicate the level of potential hazard with the labels of “**Caution**,” “**Warning**” or “**Danger**.” They are all important notes for safety and must be followed in addition to International Standards (ISO/IEC)*1), and other safety regulations.

 **Danger :** **Danger** indicates a hazard with a high level of risk which, if not avoided, will result in death or serious injury.

 **Warning:** **Warning** indicates a hazard with a medium level of risk which, if not avoided, could result in death or serious injury.

 **Caution:** **Caution** indicates a hazard with a low level of risk which, if not avoided, could result in minor or moderate injury.

*1) ISO 4414: Pneumatic fluid power - General rules and safety requirements for systems and their components
ISO 4413: Hydraulic fluid power - General rules and safety requirements for systems and their components
IEC 60204-1: Safety of machinery - Electrical equipment of machines - Part 1: General requirements
ISO 10218-1: Robots and robotic devices - Safety requirements for industrial robots - Part 1: Robots etc.

Warning

1. The compatibility of the product is the responsibility of the person who designs the equipment or decides its specifications.

Since the product specified here is used under various operating conditions, its compatibility with specific equipment must be decided by the person who designs the equipment or decides its specifications based on necessary analysis and test results. The expected performance and safety assurance of the equipment will be the responsibility of the person who has determined its compatibility with the product. This person should also continuously review all specifications of the product referring to its latest catalog information, with a view to giving due consideration to any possibility of equipment failure when configuring the equipment.

2. Only personnel with appropriate training should operate machinery and equipment.

The product specified here may become unsafe if handled incorrectly. The assembly, operation and maintenance of machines or equipment including our products must be performed by an operator who is appropriately trained and experienced.

3. Do not service or attempt to remove product and machinery/equipment until safety is confirmed.

1. The inspection and maintenance of machinery/equipment should only be performed after measures to prevent falling or runaway of the driven objects have been confirmed.
2. When the product is to be removed, confirm that the safety measures as mentioned above are implemented and the power from any appropriate source is cut, and read and understand the specific product precautions of all relevant products carefully.
3. Before machinery/equipment is restarted, take measures to prevent unexpected operation and malfunction.

4. Our products cannot be used beyond their specifications. Our products are not developed, designed, and manufactured to be used under the following conditions or environments. Use under such conditions or environments is not covered.

1. Conditions and environments outside of the given specifications, or use outdoors or in a place exposed to direct sunlight.
2. Use for nuclear power, railways, aviation, space equipment, ships, vehicles, military application, equipment affecting human life, body, and property, fuel equipment, entertainment equipment, emergency shut-off circuits, press clutches, brake circuits, safety equipment, etc., and use for applications that do not conform to standard specifications such as catalogs and operation manuals.
3. Use for interlock circuits, except for use with double interlock such as installing a mechanical protection function in case of failure. Please periodically inspect the product to confirm that the product is operating properly.

Caution

We develop, design, and manufacture our products to be used for automatic control equipment, and provide them for peaceful use in manufacturing industries.

Use in non-manufacturing industries is not covered.

Products we manufacture and sell cannot be used for the purpose of transactions or certification specified in the Measurement Act.

The new Measurement Act prohibits use of any unit other than SI units in Japan.

Limited warranty and Disclaimer/ Compliance Requirements

The product used is subject to the following “Limited warranty and Disclaimer” and “Compliance Requirements”.

Read and accept them before using the product.

Limited warranty and Disclaimer

1. The warranty period of the product is 1 year in service or 1.5 years after the product is delivered, whichever is first.*2)
Also, the product may have specified durability, running distance or replacement parts. Please consult your nearest sales branch.
2. For any failure or damage reported within the warranty period which is clearly our responsibility, a replacement product or necessary parts will be provided.
This limited warranty applies only to our product independently, and not to any other damage incurred due to the failure of the product.
3. Prior to using SMC products, please read and understand the warranty terms and disclaimers noted in the specified catalog for the particular products.

*2) **Vacuum pads are excluded from this 1 year warranty.**

A vacuum pad is a consumable part, so it is warranted for a year after it is delivered. Also, even within the warranty period, the wear of a product due to the use of the vacuum pad or failure due to the deterioration of rubber material are not covered by the limited warranty.

Compliance Requirements

1. The use of SMC products with production equipment for the manufacture of weapons of mass destruction (WMD) or any other weapon is strictly prohibited.
2. The exports of SMC products or technology from one country to another are governed by the relevant security laws and regulations of the countries involved in the transaction. Prior to the shipment of a SMC product to another country, assure that all local rules governing that export are known and followed.



LSP Series

Specific Product Precautions 1

Be sure to read this before handling the products. Refer to the back cover for safety instructions and the "Operation Manual" for handling the products. Please download the Operation Manual via our website, <https://www.smcworld.com>

Design / Selection

Warning

- 1. Do not use this product in applications which may adversely affect human life (e.g. medical equipment connected to the human body for drip infusion).**
- 2. Confirm the specifications.**

Give careful consideration to the operating conditions such as the application, fluid and environment, and use within the operating ranges specified in this catalog.
- 3. Do not apply pressure to the pump. If the pump operates with pressure applied, the repeatability may decrease or liquid may leak to the OUT side when the pump is off.**

* Refer to page 4 "Piping, Caution 1." for the installation position of the pump.
- 4. For stable dispensing, please use the product under stable operating conditions (suction height, ambient temperature, fluid temperature). If air bubbles are present in the fluid and the piping material is soft, it may influence on the repeatability of the dispense volume. Install the pump vertically facing downward so that air bubbles in the pump are removed easily. It is recommended to degasify the fluid and use hard material for piping.**

When the piping diameter of the fluid outlet is large, repeatability may be influenced by surface tension, so it is recommended to use proper piping diameter with the installation of a nozzle.
- 5. Repeatability**

Measure the amount of clear water which is dispensed 10 times continuously and convert it to one shot of dispensed volume. Repeat this measurement 10 times, and indicate the difference (%) between the average value of 10 sets of data (converted value of one shot) and the maximum and minimum values. These values are calculated based on SMC measurement conditions, so the repeatability accuracy is not guaranteed.

<Variation in SMC measurement conditions> * Tank liquid level must be lower than the pump and the OUT side tube end must be higher than the tank liquid level. Remove any air bubbles in the piping and pump chamber.

Ambient/Fluid temperatures: $\pm 2^{\circ}\text{C}$, IN/OUT side piping pressure: ± 0.1 kPa or less, Applied voltage: ± 0.01 V
- 6. Fluid**

Be sure to confirm the compatibility between the component material and the fluid. Since the compatibility of the fluid used may vary depending on its type, additives, concentration, temperature, etc., give sufficient consideration when selecting the material.

If the fluid contains foreign matter, it may be caught in the seat or cause wear on the inside of the pump, causing problems. Install an appropriate filter (strainer) before the pump. As a guide, the appropriate filtration is approximately 50 μm .

When transferring a coagulable liquid, take measures to prevent it from coagulating in the pump.

This product is not designed to be explosion proof, so it is not suitable for flammable fluids.
- 7. Dispense volume will vary depending on the fluid and piping conditions.**

After mounting is complete, perform appropriate functional inspections.

Warning

- 8. Maintenance space**

The installation should allow sufficient space for maintenance activities.
- 9. Ambient environment**

Use within the allowable ambient temperature range. Be sure that the liquid or corrosive gas does not touch the external surface of the product. Specifically, do not expose the solenoid to fluid. This may cause short circuit. When touching the wet solenoid, an electric shock may occur.
- 10. Countermeasures against static electricity**

Take measures to prevent static electricity since some fluids can cause static electricity.
- 11. Energizing for extended periods of time**

If the pump is continuously energized for long periods of time, temperature rise due to heat generation of the coil may result in reduced performance and shorter service life or adversely affect the peripheral device. Therefore, if the pump is energized for long periods, take measures to cool the pump by mounting a fan to keep the surface temperature at 50°C or less. When the pump is mounted into a control panel, take measures to cool the pump and keep the operating temperature within the specified range.
- 12. If the product has not been used for long periods of time, perform a trial run before use. If the product is to remain inactive for long periods of time, remove the fluid from the pump.**
- 13. Do not touch the pump directly with hands. The coil can be hot depending on the ambient temperature or energizing time. Install a protective cover over the valve if it can be touched directly with hands.**
- 14. Leakage voltage**

Voltages caused by leakage current may lead to pump malfunction.

Leakage voltage: 2% or less of the rated voltage

Mounting

Warning

- 1. If equipment does not operate properly, stop operation.**

After mounting is completed, confirm that it has been done correctly by performing a suitable function test.
- 2. For stable dispensing, mount the coil vertically facing downward so that bubbles in the pump are removed easily.**

After releasing air bubbles, mounting orientation is not specified.
- 3. Do not use this product in a location where it will be subject to vibration or impact. The dispense volume may become unstable in the presence of vibration at the pump or piping.**
- 4. Do not apply external force to the coil section.**
- 5. Install and operate the product only after reading the operation manual carefully and understanding its contents.**



LSP Series

Specific Product Precautions 2

Be sure to read this before handling the products. Refer to the back cover for safety instructions and the "Operation Manual" for handling the products. Please download the Operation Manual via our website, <https://www.smcworld.com>

Piping

Caution

1. Do not apply pressure to the pump. If the pump operates with pressure applied, the repeatability may decrease or liquid may leak to the OUT side when the pump is off. Tank liquid level must be lower than the pump and the OUT side tube end must be higher than the tank liquid level. Remove any air bubbles in the piping and pump chamber.

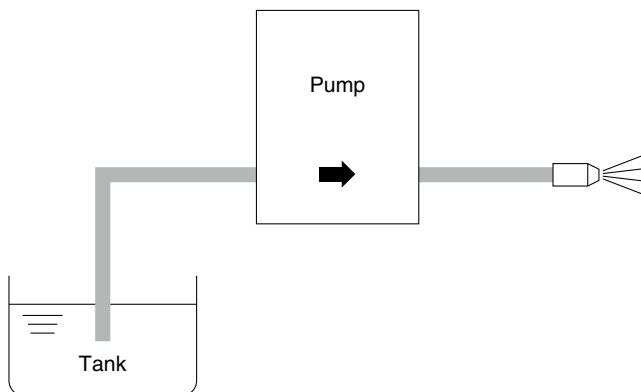

2. Make sure to remove any air bubbles in the piping and pump chamber before use.
3. Preparation before piping
Before piping is connected, it should be thoroughly blown out with air (flushing) or washed to remove chips, cutting oil and other debris from inside the pipe.
4. Always tighten threads with the proper tightening torque.

When piping the fitting to the body ported (threaded ports), the installation method and tightening torque value may vary depending on the seal structure (shape) or material of the fitting to be used. Check the methods and precautions recommended by the fitting manufacturer to be used, and be sure to check for leakage. It is customer's responsibility to verify the compatibility of the fitting and operating liquid.

The table below indicates the reference value when KQ2 series is used for water.

Model		Thread size	Tightening method	Tightening torque [N·m] (Reference)
Body ported (Threaded ports)	LSP1□1-□A(B)1	M5	After tightening by hand, tighten 1/6 to 1/4 turn with a tightening tool.	0.5 to 0.7
	LSP1□1-□C(D)1			0.3 to 0.35
	LSP1□1-□A(B)2(3)	M6	After tightening by hand, tighten 1/6 to 1/4 turn with a tightening tool.	0.6 to 0.8
	LSP1□1-□C(D)2(3)	1/4-28UNF		0.4 to 0.45

When mounting the pump, tighten it with the proper tightening torque shown below. For base mounted, tighten the screw surely to the correct torque in the table below after confirming that the O-ring is mounted on the interface properly.

Model		Thread size	Proper tightening torque [N·m]
Body ported (Tube connection type)/Base mounted, Body mounting	LSP1□1-□A(B)4 LSP1□2-□A(B)	M2	0.15 to 0.2
	LSP1□1-□C(D)4 LSP1□2-□C(D)		0.1 to 0.15
Body ported (Threaded ports), Body mounting	LSP1□1-□A(B)1(2, 3) LSP1□1-□C(D)1(2, 3)	M3	0.4 to 0.6
			0.2 to 0.25

5. Mount the pump on the flat surface.
Applicable model: All models
6. Remove dust from the pump mounting surface completely.
The surface roughness of the mounting surface should be Rz3.2 or less.
Applicable model: Base mounted
7. When connecting tubing to the tube connection type, please make sure inserting it straight to the end of the tube inlet.
If external force of 10 N or more is applied to tube inlet, the inlet may become damaged, and leakage or breakage could occur.
Select appropriate tubing while referring to the table below.

Model	Tube inside diameter (I.D.)	Tubing outside diameter (O.D.) (after mounting)
LSP1□1-□□4	ø2 or less	ø5.8 or less

The holding force varies by the tubing material. Be sure to confirm the holding force of each material before operation. After connecting the tubing, please do not apply load such as tensile force, compression, or bending force.

8. When the tubing is long or according to the operating conditions, tubing may thrash about, causing damage to the tube inlet of the pump, or the tubing to come off or deteriorate. In this case, secure the tubing to prevent its uncontrolled movement.
9. If the removed tubing is to be used again, cut off the section of the tubing which has been gripped by the fitting.



LSP Series

Specific Product Precautions 3

Be sure to read this before handling the products. Refer to the back cover for safety instructions and the "Operation Manual" for handling the products. Please download the Operation Manual via our website, <https://www.smcworld.com>

Wiring

Caution

- 1. Use electrical circuits which do not generate chattering in their contacts.**
- 2. Use voltage which is within $\pm 10\%$ of the rated voltage.**
However, when response time is prioritized, or dispensing is difficult due to high fluid viscosity or high piping resistance, control the voltage so that there is no fluctuation below the rated voltage.
- 3. Apply the correct voltage.**
Applying incorrect voltage may cause a malfunction or a burned coil.
- 4. Make sure that no excessive force is applied to the lead wires.**
Otherwise, the coil will burn.
- 5. Electrical polarity does not matter.**

Fluid Quality

Warning

When component crystallizes or clots depending on its nature, malfunction will occur due to the diaphragm or check valve sticking. When a crystallized or clotted component is caught between the sealing parts, unstable liquid dispensing will occur. Take measures to clean such component if necessary.

Operating Environment

Warning

- 1. Do not use in explosive atmospheres.**
- 2. Do not use in locations subject to excessive vibration or impact.**
- 3. Do not use in locations where radiated heat will be received from nearby heat sources.**

Maintenance

Warning

- 1. Removing the product**
Shut off the fluid supply and release the fluid pressure in the system. Shut off the power supply. Remove the product.
- 2. Before operating, remove residual chemicals and completely replace it with deionized water, air, etc.**
- 3. Do not disassemble the product.**
Products which have been disassembled cannot be guaranteed.

Adjustment of dispense volume is possible.

Dispense volume can be changed by adjusting the armature stroke with adjusting screw.

Dispense volume:

- 5 to 50 μL per shot
- 50 to 100 μL per shot
- 100 to 200 μL per shot

Stable dispense volume

Repeatability: $\pm 1\%$ *1, *2

Diaphragm movement is supported by buffer. Stable dispense volume and longer life can be achieved by restricting deformation of the diaphragm.

*1 $\pm 2\%$ at 5 to 15 μL *2

*2 Under SMC's measurement conditions

Shut-off function

Liquid leakage due to a siphonic phenomenon can be prevented by seating with diaphragm. No need to install an external shut-off valve designed to prevent leakage before and after the pump.

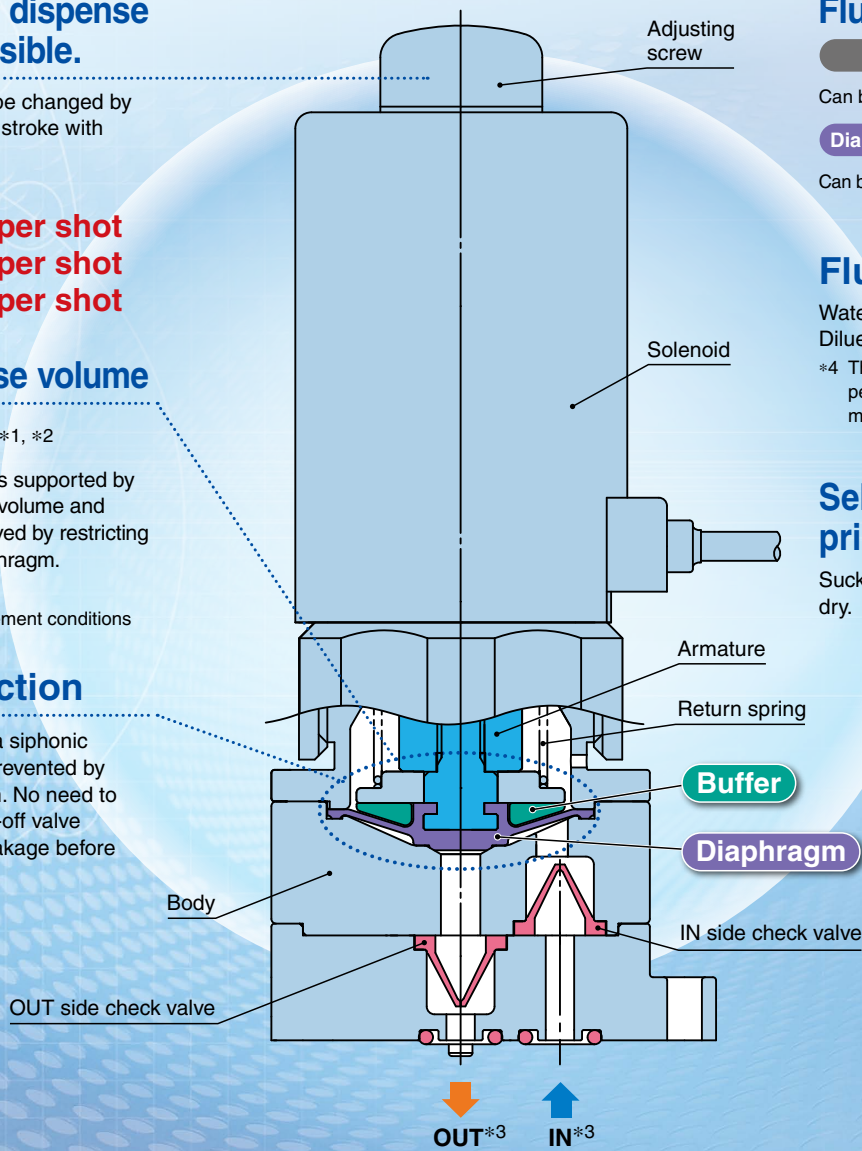

*3 Do not apply positive or vacuum pressure to IN or OUT port.

Fluid contact material

Body

Can be selected from **PEEK or PP**

Diaphragm, Check valve

Can be selected from **EPDM or FKM**

Fluid *4

Water, DI water (Pure water), Diluent, or Cleaning fluid

*4 These fluids should not corrode or permeate into the fluid contact materials.

Self-priming makes priming unnecessary.

Sucks the liquid even if the pump is dry.

Application Examples

Analyzer (for medical/biochemical)



Ink jet printing

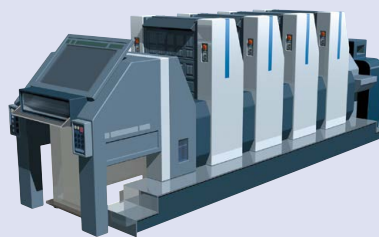

Related to semiconductor/solar cell



Liquid Dispense Pump (Solenoid Type)

LSP Series



How to Order

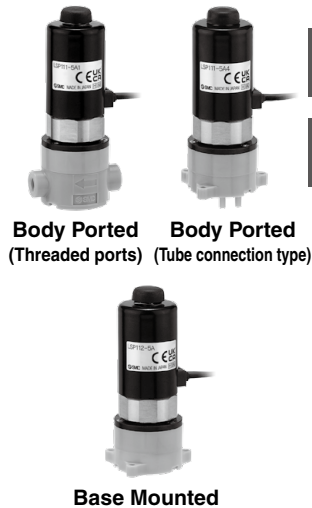

Body Ported LSP1 1 1 - 5 A 1
Base Mounted LSP1 1 2 - 5 A

● Dispense volume ●

1	5 to 50 μ L
2	50 to 100 μ L
3	100 to 200 μ L

● Coil voltage ●

5	24 VDC
6	12 VDC

● Port size

1	M5 thread
2	M6 thread
3	1/4-28UNF thread
4	Tube connection type

● Fluid contact material

Symbol	Body	Diaphragm	Check valve
A	PEEK	EPDM	EPDM
B	PEEK	FKM	FKM
C	PP	EPDM	EPDM
D	PP	FKM	FKM

Specifications

Model		LSP111/112	LSP121/122	LSP131/132
Dispense volume adjustable range*1		5 to 50 μ L	50 to 100 μ L	100 to 200 μ L
Fluid*4 Water, DI water (Pure water), Diluent, or Cleaning fluid (These fluids should not corrode or permeate into the fluid contact materials.)				
Fluid contact material	Body	PEEK, PP		
	Diaphragm	EPDM, FKM		
	Check valve	EPDM, FKM		
Repeatability*1		$\pm 1\%$ ($\pm 2\%$ at 5 to 15 μ L) * Under SMC's measurement conditions		
Dispense pressure*2		10 kPa		
Suction pressure*2	Dry	15 kPa		
	Wet	35 kPa		
Max. operating frequency*3		2 Hz (Minimum ON time 200 ms/Minimum OFF time 300 ms)		
Fluid temperature		10 to 50°C (No freezing)		
Ambient temperature		10 to 50°C (No freezing)		
Mounting orientation		Unrestricted*5		
Enclosure		Equivalent to IP40		
Weight	Body ported	90 g		
	Threaded ports	85 g		
	Tube connection type	85 g		
Base mounted		85 g		
Rated voltage		12 VDC, 24 VDC		
Allowable voltage fluctuation		$\pm 10\%$ of the rated voltage*6		
Type of coil insulation		Class B		
Lead wire		AWG20 (Outside diameter of insulator: 1.79 mm)		
Power consumption		4 W	9 W	17 W
Operation noise		60 dB or less *7		

*1 The values above are at room temperature with clear water at zero pressure. The dispense volume and repeatability will vary depending on the piping conditions (height, diameter, length, etc.), of the INLET and OUTLET sides, fluids, and the ambient and fluid temperatures, etc. For stable dispensing, use the product under stable operating conditions where pressure is not applied to the INLET and OUTLET side as much as possible.

Do not apply excessive torque when rotating the dispensing volume adjusting screw. If the screw is tightened too much, it may lead to product failure or cause the screw to shear. For details on repeatability, refer to page 3 "Design / Selection, 5. Repeatability."

<Variation in SMC measurement conditions> * Refer to page 4 "Piping, Caution 1." for the installation position of the pump.

Ambient/Fluid temperatures: $\pm 2^\circ\text{C}$, IN/OUT side piping pressure: ± 0.1 kPa or less, Applied voltage: ± 0.01 V

*2 The value is measured when the max. dispense volume of clear water at room temperature is adjusted. This value will vary depending on the dispense volume and fluid conditions.

*3 High-speed operation affects the dispense volume and accuracy. The max. operation frequency is decreased by the fluid characteristics (large viscosity) and the piping condition (large piping resistance). When the pump is used continuously for extended periods of time, make the OFF time appropriately longer with the minimum ON time of 200 ms to set the operating frequency to 1 Hz or less. Since the coil temperature may rise due to ambient temperature and energizing time, so make the OFF time appropriately longer.

*4 Select an appropriate fluid contact material when fluid such as cleaning liquid is used. Also, check the fluid compatibility in advance. Some fluids may have an influence on the dispense volume and repeatability. After mounting is complete, perform appropriate functional inspections.

This product is not designed to be explosion proof, so it is not suitable for flammable fluids.

*5 For stable dispensing, we recommend that the coil is mounted vertically facing downward or OUTLET side facing upward so that air bubbles are removed easily. Also, dispense liquids by operating the product continuously to remove any air bubbles in the piping and pump chamber. It is recommended to degasify the fluid before use.

*6 When response time is prioritized, or dispensing is difficult due to high fluid viscosity or high piping resistance, control the voltage so that there is no fluctuation below the rated voltage.

*7 The value above is under SMC's measurement conditions, and will vary depending on the conditions.

LSP Series

Construction

Body Ported (Threaded ports) LSP1□1

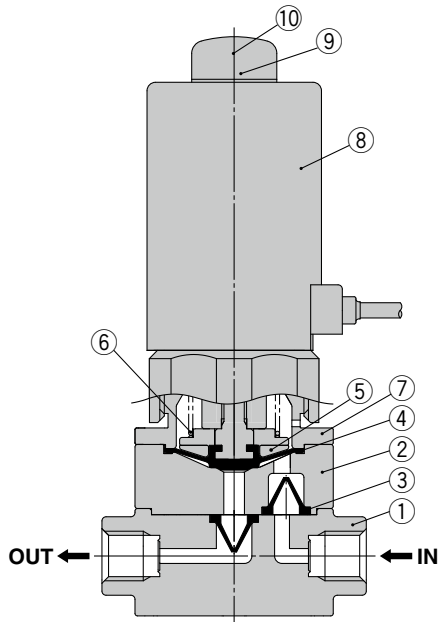

Body Ported (Tube connection type) LSP1□1

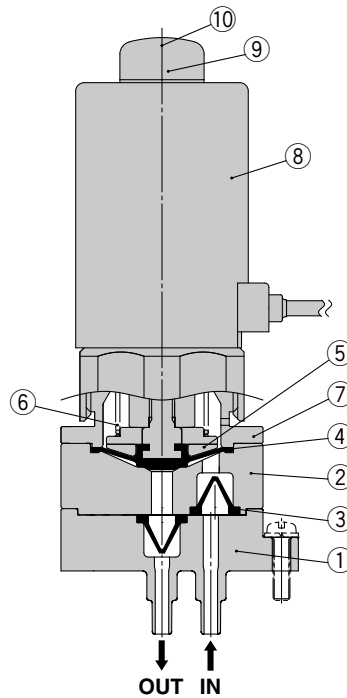

Base Mounted LSP1□2

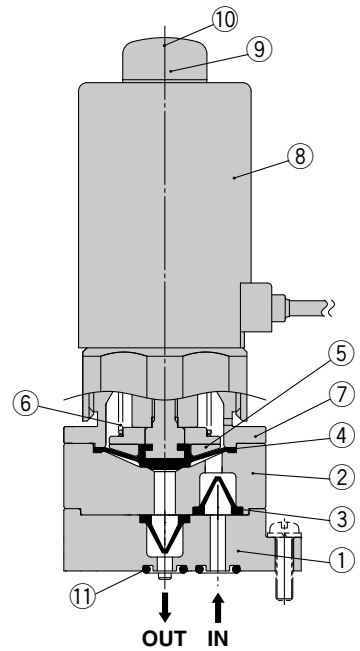

Working Principle

When the pump turns ON (energized), the diaphragm will perform a stroke to the solenoid side. This condition makes the pressure in the pump chamber negative and the check valve on the OUT side is closed. Fluid passed through the suction port then the check valve on the IN side is sucked in the pump chamber.

When the pump turns OFF (de-energized), the diaphragm will perform a stroke to the body side with return force of the return spring. Due to this, the check valve on the IN side is closed, and fluid in the pump chamber is passed through the check valve on the OUT side and is dispensed from the outlet.

Suction and dispensing are repeated with repetitive ON/OFF operation.

Component Parts

No.	Description	Material
1	Plate	PEEK, PP
2	Body	PEEK, PP
3	Check valve	EPDM, FKM
4	Diaphragm	EPDM, FKM
5	Buffer	NBR
6	Return spring	Stainless steel
7	Housing	PPS
8	Solenoid	—
9	Dispensing volume adjusting screw	Stainless steel
10	Cap	EPDM
11	O-ring	EPDM, FKM

Dispense Volume Adjustment

The dispense volume per shot can be changed by rotating the dispensing volume adjusting screw.

When rotating the dispensing volume adjusting screw clockwise, the dispense volume decreases. When rotating it counterclockwise, the dispense volume increases.

Step 1 Remove the cap and loosen the lock nut while holding the dispensing volume adjusting screw with a flat blade screwdriver to prevent it from rotating. (Counterclockwise)

Step 2 Rotate the dispensing volume adjusting screw to adjust the dispense volume. Refer to the drawing on the right and the table below as reference for the range of the dispensing volume adjusting screw.

- * Do not apply excessive torque when rotating the dispensing volume adjusting screw. If the screw is tightened too much, it may lead to product failure or cause the screw to shear. Adjust the dispense volume gradually to avoid breakage of the inner parts due to tightening the adjusting screw too much.
- * When the dispensing volume adjusting screw is close to the maximum adjustment level, the noise may be loud. In this case, turn the screw clockwise until the noise is reduced.

	LSP11□	LSP12□	LSP13□
Upper limit of the adjustment (fully open)	Approx. 3 mm		
Adjustment range (Clockwise)	1.5 turns	2 turns	2.5 turns

Step 3 Tighten the lock nut while holding the dispensing volume adjusting screw with a flat blade screwdriver to prevent it from rotating. (Clockwise)

- * Lock nut tightening torque: 0.6 to 0.8 N·m

* Ensure that the lock nut is secured after adjusting the dispense volume.

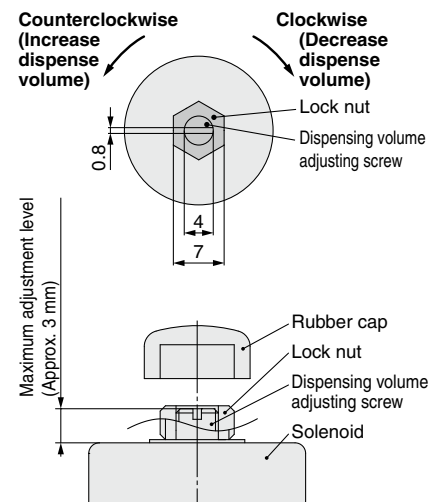

Dimensions

Body Ported (Threaded ports)

LSP1□1

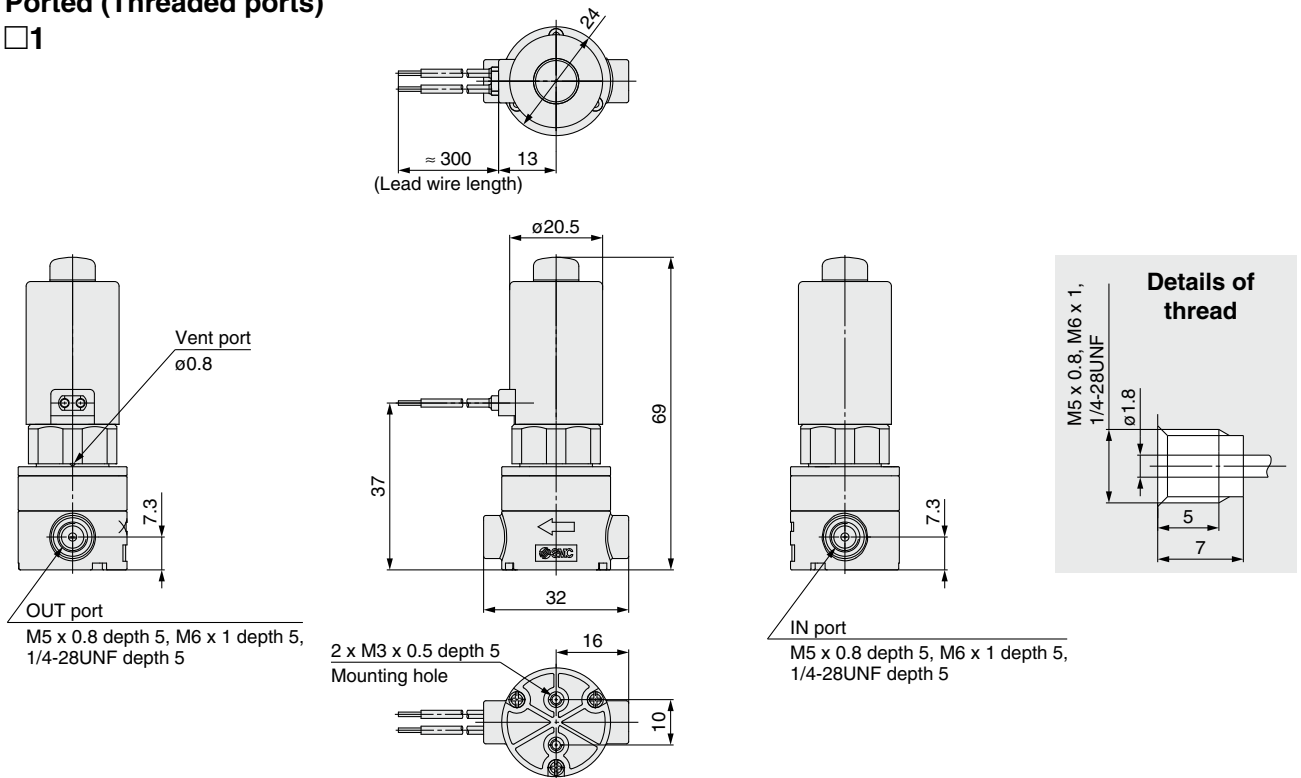

Body Ported (Tube connection type)

LSP1□1

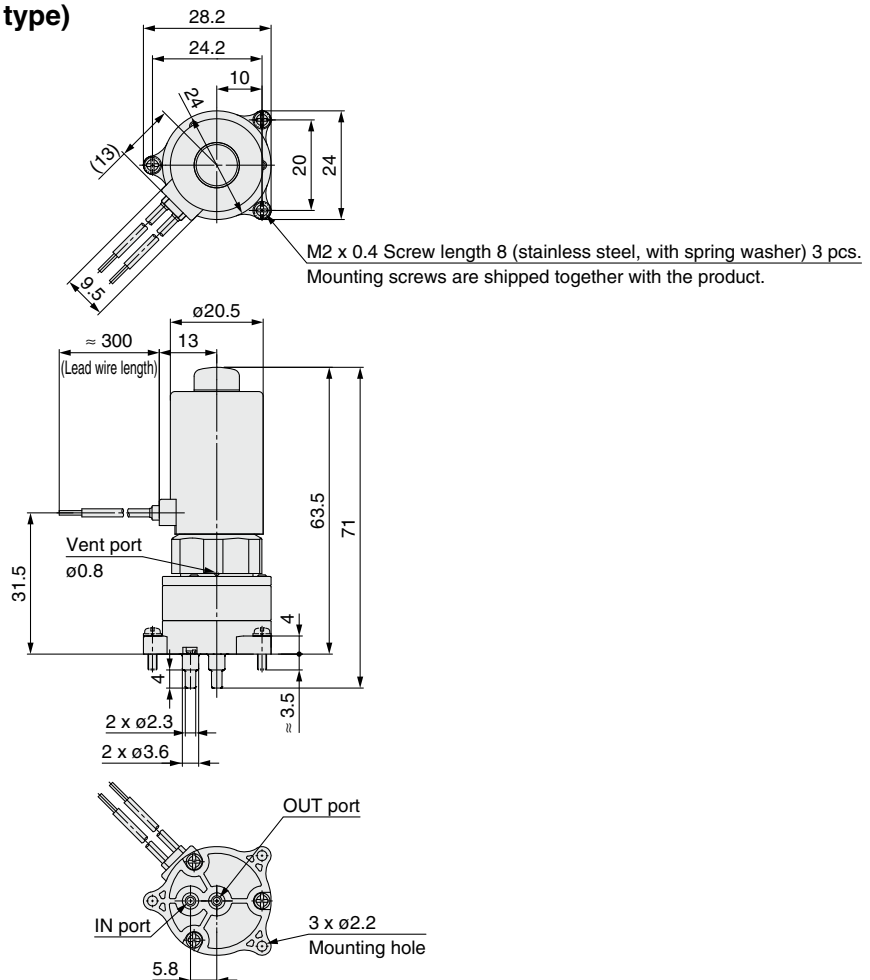

LSP Series

Dimensions

Base Mounted LSP1□2

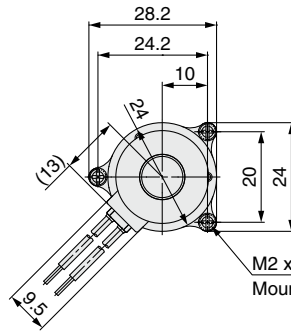

M2 x 0.4 screw length 8 (stainless steel, with spring washer) 3 pcs.
Mounting screws are shipped together with the product.

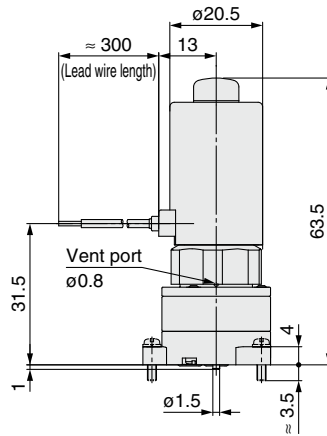

Recommended interface dimensions

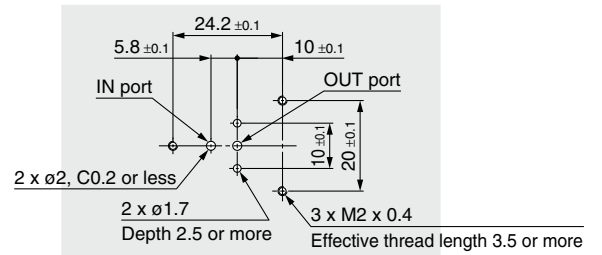

* Surface roughness is Rz3.2 or less

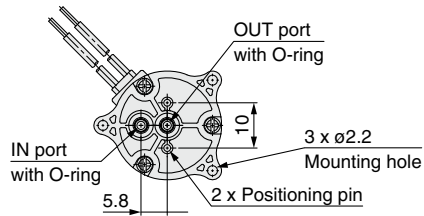

Countermeasures

If any abnormality is found, perform checks according to the following list. If the abnormality cannot be eliminated, contact your SMC representative.



Warning

Discharge fluids from the pump. Eliminate the residual fluids, and thoroughly clean the product with pure water or air. Do not disassemble the product, as this could allow contact with any residual chemicals.

Problem	Possible causes	Countermeasures
1) The product does not operate when power is applied.	<ul style="list-style-type: none"> - Lead wire connection is defective. - Non-conformance of electric system - The suction port (IN) or dispense port (OUT) are closed or resistance is too large. - Defect in the body - Diaphragm breakage - Broken wire in the coil. - Piping blocked. - Sealing failure on the suction (IN) side. - Intrusion of air from the suction (IN) side. - Suction (IN) side filter blocked. - Catching of foreign matter in the check valve. 	<ul style="list-style-type: none"> - Check wiring. - Check electric system. - Review the piping on the suction and dispense port and remove the orifice. - Replace the pump. - Replace the pump. - Replace the pump. - Clean or replace the piping. - Check sealing of the piping. - Check the piping on the suction (IN) side. - Clean or replace the filter. - Install the filter to the suction (IN) side.
2) Pump operates, but does not dispense.	<p>There is no suction.</p> <ul style="list-style-type: none"> - Check valve sticking or blocked. - Excessive pump head on the suction (IN) side. - Excessive fluid viscosity. - Breakage or wear of the check valve. 	<ul style="list-style-type: none"> - Clean the check valve. - Reduce the pump head on the suction (IN) side. - Use fluid of the recommended viscosity. - Replace the pump. - Replace the pump, check the compatibility of the fluid contact parts.
The product creates suction, but does not dispense.	<ul style="list-style-type: none"> - Swelling, contraction or deterioration of the diaphragm/check valve. - Diaphragm breakage. - Piping blocked. - Check valve sticking or blocked. 	<ul style="list-style-type: none"> - Replace the pump. - Clean or replace the piping. - Clean the check valve.

Problem	Possible causes	Countermeasures
3) Insufficient dispense volume.	<ul style="list-style-type: none"> - Dispense volume adjusting screw incorrectly set. - Excessive fluid viscosity. - Operating frequency is too high. - Piping diameter is too small. - Suction side (IN) filter blocked. - Excessive pump head on the suction (IN) side and dispense (OUT) side. - Ambient temperature is too high - Coil temperature increase due to continuous operation. - Intrusion of air from the suction (IN) / dispense (OUT) side. - Residual bubbles in the piping or pump chamber. - Dissolved gas in fluid vaporizes in piping and pump chambers - Power supply under voltage. - Check valve sticking or blocked. - The lock nut for adjusting the dispense amount is loose. - Excessive fluid viscosity. - Operating frequency is too high. 	<ul style="list-style-type: none"> - Adjust dispense volume screw until correct dispense obtained. - Use fluid of the recommended viscosity. - The frequency should be set at or below the maximum operating frequency. - Increase the piping diameter. - Clean or replace the filter. - Reduce the pump head on the suction (IN) side and dispense (OUT) side. - Decrease the ambient temperature. - Decrease the operation frequency by increasing OFF time and by setting ON time to 200msec - Increase cooling around pump by installing fans, etc. - Check the piping on the suction (IN) / dispense (OUT) side. - Eliminate bubbles in the piping and pump chamber. - Use degassed fluid - Check power supply. - Perform cleaning. - Tighten the lock nut at standard torque (0.6 to 0.8Nm). - Use fluid of the recommended viscosity. The frequency should be set at or below the maximum operating frequency.
4) dispense amount is unstable	<ul style="list-style-type: none"> - The diameter of the piping or nozzle is too small/ large. - Ambient and fluid temperature change is large. - Tank fluid level of the suction (IN) side is higher than the pump. - Tube end position of the dispense (OUT) side is lower than the tank fluid level. - Fluctuation of the tank fluid level of the suction (IN) side is large. - Excessive pump head on the suction (IN) side and dispense (OUT) side. - Fluctuation of the suction and dispense pressure of the suction (IN) and dispense (OUT) side is large. - Tube is made of soft piping material - Sealing failure on the suction (IN) side or dispense (OUT) side. - Large voltage fluctuation. - Check valve sticking or blocked. - Suction side (IN) filter blocked. 	<ul style="list-style-type: none"> - Change the diameter of the piping or nozzle. - Stabilize the ambient and fluid temperature - Lower the tank fluid level of the suction (IN) side below the pump position. - Change the tube end position of the dispense(OUT) side to the position higher than the tank fluid level. - Reduce the fluctuation of the tank fluid level of the suction (IN) side. - Reduce the pump head on the suction (IN) side and dispense (OUT) side. - Stabilize the suction and dispense pressure of the suction (IN) and dispense (OUT) side. - Use the tube made of hard piping material. - Check sealing of the piping. - Stabilize the power supply voltage - Clean the check valve. - Clean or replace the filter.

Problem	Possible causes	Countermeasures
5) Leakage of fluids from pump connections.	<ul style="list-style-type: none"> - Intrusion of air from the suction (IN) side. . - Sealing failure on the suction (IN) side or dispense (OUT) side. - Diaphragm breakage. 	<ul style="list-style-type: none"> - Check the piping on the suction (IN) side. - Check sealing of the piping. - Replace the pump.
6) Fluid leakage to the outside.	<ul style="list-style-type: none"> - Body piping connections insecure. - Diaphragm breakage - Swelling, contraction or deterioration of the diaphragm/check valve. 	<ul style="list-style-type: none"> - Re-tighten connections and check that piping are secure. - Replace the pump. - Replace the pump.

Revision history

- A: Tube connection type added
Precautions change
- B: Fixed failure countermeasures
- C: Safety Instructions changed.

SMC Corporation

Tel: + 81 3 5207 8249 Fax: +81 3 5298 5362
URL <https://www.smcworld.com>

Note: Specifications are subject to change without prior notice and any obligation on the part of the manufacturer.
© SMC Corporation All Rights Reserved