



Operation Manual

PRODUCT NAME

AC Servo Motor Driver (Network card type)

MODEL/ Series

LECSND2-T□ Series



SMC Corporation



LECSND2-T□ Series / Driver

1. Safety Instructions

These safety instructions are intended to prevent hazardous situations and/or equipment damage. These instructions indicate the level of potential hazard with the labels of "Caution," "Warning" or "Danger." They are all important notes for safety and must be followed in addition to International Standards (ISO/IEC), *1) and other safety regulations.

- *1) ISO 4414: Pneumatic fluid power -- General rules relating to systems
- ISO 4413: Hydraulic fluid power -- General rules relating to systems
- IEC 60204-1: Safety of machinery -- Electrical equipment of machines (Part 1: General requirements)
- ISO 10218: Manipulating industrial robots -- Safety

	Caution	Caution indicates a hazard with a low level of risk which, if not avoided, could result in minor or moderate injury.
	Warning	Warning indicates a hazard with a medium level of risk which, if not avoided, could result in death or serious injury.
	Danger	Danger indicates a hazard with a high level of risk which, if not avoided, will result in death or serious injury.

Warning

1. The compatibility of the product is the responsibility of the person who designs the equipment or decides its specifications.

Since the product specified here is used under various operating conditions, its compatibility with specific equipment must be decided by the person who designs the equipment or decides its specifications based on necessary analysis and test results.

The expected performance and safety assurance of the equipment will be the responsibility of the person who has determined its compatibility with the product.

This person should also continuously review all specifications of the product referring to its latest catalog information, with a view to giving due consideration to any possibility of equipment failure when configuring the equipment.

2. Only personnel with appropriate training should operate machinery and equipment.

The product specified here may become unsafe if handled incorrectly.

The assembly, operation and maintenance of machines or equipment including our products must be performed by an operator who is appropriately trained and experienced.

3. Do not service or attempt to remove product and machinery/equipment until safety is confirmed.

The inspection and maintenance of machinery/equipment should only be performed after measures to prevent falling or runaway of the driven objects have been confirmed.

When the product is to be removed, confirm that the safety measures as mentioned above are implemented and the power from any appropriate source is cut, and read and understand the specific product precautions of all relevant products carefully.





Before machinery/equipment is restarted, take measures to prevent unexpected operation and malfunction.

4. Contact SMC beforehand and take special consideration of safety measures if the product is to be used in any of the following conditions.

- 1) Conditions and environments outside of the given specifications, or use outdoors or in a place exposed to direct sunlight.
- 2) Installation on equipment in conjunction with atomic energy, railways, air navigation, space, shipping, vehicles, military, medical treatment, combustion and recreation, or equipment in contact with food and beverages, emergency stop circuits, clutch and brake circuits in press applications, safety equipment or other applications unsuitable for the standard specifications described in the product catalog.
- 3) An application which could have negative effects on people, property, or animals requiring special safety analysis.
- 4) Use in an interlock circuit, which requires the provision of double interlock for possible failure by using a mechanical protective function, and periodical checks to confirm proper operation.

Note that the CAUTION level may lead to a serious consequence according to conditions. Please follow the instructions of both levels because they are important to personnel safety.

What must not be done and what must be done are indicated by the following diagrammatic symbols.

	Prohibition	Indicates what must not be done. For example, "No Fire" is indicated by	
	Compulsion	Indicates what must be done. For example, grounding is indicated by	

In this Instruction Manual, instructions at a lower level than the above, instructions for other functions, and so on are classified into "POINT".

After reading this installation guide, always keep it accessible to the operator.



LECSND2-T□ Series / Driver

1. Safety Instructions

Caution

The product is provided for use in manufacturing industries.

The product herein described is basically provided for peaceful use in manufacturing industries.

If considering using the product in other industries, consult SMC beforehand and exchange specifications or a contract if necessary.

If anything is unclear, contact your nearest sales branch.

Limited warranty and Disclaimer/Compliance Requirements

The product used is subject to the following “Limited warranty and Disclaimer” and “Compliance Requirements”.

Read and accept them before using the product.

Limited warranty and Disclaimer

The warranty period of the product is 1 year in service or 1.5 years after the product is delivered, whichever is first.*3)

Also, the product may have specified durability, running distance or replacement parts. Please consult your nearest sales branch.

For any failure or damage reported within the warranty period which is clearly our responsibility, a replacement product or necessary parts will be provided.

This limited warranty applies only to our product independently, and not to any other damage incurred due to the failure of the product.

Prior to using SMC products, please read and understand the warranty terms and disclaimers noted in the specified catalog for the particular products.

***3) Vacuum pads are excluded from this 1 year warranty.**

A vacuum pad is a consumable part, so it is warranted for a year after it is delivered.

Also, even within the warranty period, the wear of a product due to the use of the vacuum pad or failure due to the deterioration of rubber material are not covered by the limited warranty.

Compliance Requirements

When the product is exported, strictly follow the laws required by the Ministry of Economy, Trade and Industry (Foreign Exchange and Foreign Trade Control Law).

1. To prevent electric shock, note the following

 **WARNING**

- Before wiring and inspections, turn off the power and wait for 15 minutes or more until the charge lamp turns off. Then, confirm that the voltage between P+ and N- is safe with a voltage tester and others. Otherwise, an electric shock may occur. In addition, when confirming whether the charge lamp is off or not, always confirm it from the front of the driver.
- Ground the driver and servo motor securely.
- Any person who is involved in wiring and inspection should be fully competent to do the work.
- Do not attempt to wire the driver and servo motor until they have been installed. Otherwise, it may cause an electric shock.
- Do not operate switches with wet hands. Otherwise, it may cause an electric shock.
- The cables should not be damaged, stressed, loaded, or pinched. Otherwise, it may cause an electric shock.
- During power-on or operation, do not open the front cover of the s driver. Otherwise, it may cause an electric shock.
- Do not operate the driver with the front cover removed. High-voltage terminals and charging area are exposed and you may get an electric shock.
- Except for wiring and periodic inspection, do not remove the front cover of the driver even if the power is off. The driver is charged and you may get an electric shock.
- To prevent an electric shock, always connect the protective earth (PE) terminal (marked ⊕) of the driver to the protective earth (PE) of the cabinet.
- To avoid an electric shock, insulate the connections of the power supply terminals.

2. To prevent fire, note the following

 **CAUTION**

- Install the driver, servo motor, and regenerative resistor on incombustible material. Installing it directly or close to combustibles will lead to a fire.
- Always connect a magnetic contactor between the power supply and the main circuit power supply (L1, L2, and L3) of the driver, in order to configure a circuit that shuts down the power supply on the side of the driver's power supply. If a magnetic contactor is not connected, continuous flow of a large current may cause a fire when the driver malfunctions.
- When using the regenerative resistor, switch power off with the alarm signal. Not doing so may cause a fire when a regenerative transistor malfunctions or the like may overheat the regenerative resistor.
- Provide adequate protection to prevent screws and other conductive matter, oil and other combustible matter from entering the driver and servo motor.
- Always connect a molded-case circuit breaker to the power supply of the driver.

3. To prevent injury, note the following

 **CAUTION**

- Only the voltage specified in the Instruction Manual should be applied to each terminal. Otherwise, a burst, damage, etc. may occur.
- Connect cables to the correct terminals. Otherwise, a burst, damage, etc. may occur.
- Ensure that polarity (+/-) is correct. Otherwise, a burst, damage, etc. may occur.
- The driver heat sink, regenerative resistor, servo motor, etc. may be hot while power is on or for some time after power-off. Take safety measures, e.g. provide covers, to prevent accidental contact of hands and parts (cables, etc.) with them.

4. Additional instructions

The following instructions should also be fully noted. Incorrect handling may cause a fault, injury, electric shock, etc.

(1) Transportation and installation

⚠ CAUTION

- Transport the products correctly according to their mass.
- Stacking in excess of the specified number of product packages is not allowed.
- Do not hold the front cover when transporting the driver. Otherwise, it may drop.
- Install the driver and the servo motor in a load-bearing place in accordance with the Instruction Manual.
- Do not get on or put heavy load on the equipment.
- The equipment must be installed in the specified direction.
- Leave specified clearances between the driver and the cabinet walls or other equipment.
- Do not install or operate the driver and servo motor which have been damaged or have any parts missing.
- Do not block the intake and exhaust areas of the driver. Otherwise, it may cause a malfunction.
- Do not drop or strike the driver and servo motor. Isolate them from all impact loads.
- When you keep or use the equipment, please fulfill the following environment.

Environment		Conditions		
		Driver		Servo motor
Ambient temperature	In operation	[°C]	0 to +55 (non-freezing)	0 to +40 (non-freezing)
		[°F]	32 to 131 (non-freezing)	32 to 104 (non-freezing)
	In storage	[°C]	-20 to +65 (non-freezing)	-15 to +70 (non-freezing)
		[°F]	-4 to 149 (non-freezing)	5 to 158 (non-freezing)
Ambient humidity	In operation	90%RH or less (non-condensing)		80%RH or less (non-condensing)
	In storage	90%RH or less (non-condensing)		
Ambience		Indoors (no direct sunlight) Free from corrosive gas, flammable gas, oil mist, dust and dirt		
Altitude		Max. 2000m (6560 ft) above sea level		
(Note) Vibration	[m/s ²]	5.9 or less at 10 Hz to 55 Hz (directions of X, Y and Z axes)	LECSND2-T5 LECSND2-T7 LECSND2-T8 LECSND2-T9 series	X · Y: 49

- When handling the driver, be careful about the edged parts such as corners of the driver.
- The driver must be installed in the metal cabinet.

(2) Wiring

⚠ CAUTION

- Perform wiring correctly and securely. It may cause unexpected movement of the servo motor.
- Do not attach a phase-advancing capacitor, surge killer, or radio noise filter (FR-BIF manufactured by Mitsubishi Electric Corporation) to the output side of the driver.
- Connect the driver and servo motor power phases (U, V, W) correctly, as this may cause the servo motor to malfunction.
- Connect the driver power output (U, V, and W) to the servo motor power input (U, V, and W) directly. Do not let a magnetic contactor, etc. intervene. Otherwise, it may cause a malfunction.

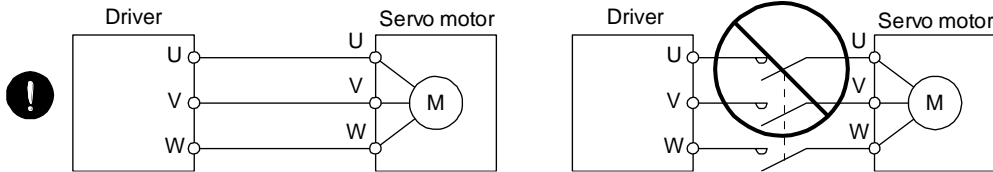

- The surge absorbing diode installed to the DC relay for control output should be fitted in the specified direction. Otherwise, the emergency stop and other protective circuits may not operate.

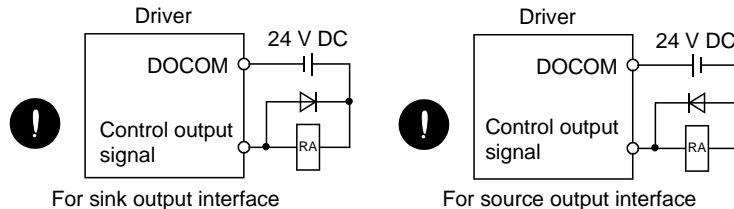

- When the cable is not tightened enough to the terminal block, the cable or terminal block may generate heat because of the poor contact. Be sure to tighten the cable with specified torque.
- Connecting a servo motor for different axis to the U, V, W, or CN2 may cause a malfunction.
- Configure a circuit turn off EM2 or EM1 when the main circuit power supply is turned off to prevent an unexpected restart of the driver.
- To prevent malfunction, avoid bundling power lines (input/output) and signal cables together or running them in parallel to each other. Separate the power lines from the signal cables.

(3) Test run and adjustment

⚠ CAUTION

- Before operation, check the parameter settings. Improper settings may cause some machines to perform unexpected operation.
- Never adjust or change the parameter values extremely as it will make operation unstable.
- Do not close to moving parts at servo-on status.

(4) Usage

⚠ CAUTION

- Provide an external emergency stop circuit to ensure that operation can be stopped and power switched off immediately.
- Do not disassemble, repair, or modify the equipment.
- Before resetting an alarm, make sure that the run signal of the driver is off in order to prevent a sudden restart. Otherwise, it may cause an accident.
- Use a noise filter to reduce the effects of electromagnetic interference. Electromagnetic interference may occur on electronic devices used near the driver.
- Do not burn or disassemble the driver, as toxic gas may be generated.

⚠ CAUTION

- Use a noise filter, etc. to minimize the influence of electromagnetic interference. Electromagnetic interference may be given to the electronic equipment used near the driver.
- Burning or breaking a driver may cause a toxic gas. Do not burn or break it.
- Use the driver with the specified servo motor.
- The lock on the servo motor is designed to hold the motor shaft and should not be used for ordinary braking.
- For such reasons as service life and mechanical structure (e.g. where a ball screw and the servo motor are coupled via a timing belt), the lock may not hold the motor shaft. To ensure safety, install a stopper on the machine side.

(5) Corrective actions

⚠ CAUTION

- When it is assumed that a hazardous condition may occur due to a power failure or product malfunction, use a servo motor with a lock or external lock to prevent the condition.
- **Do not use the 24 V DC interface power supply for the lock.**
 - Configure a lock circuit so that it is activated also by an external EMG stop switch.

Contacts must be opened when ALM (Malfunction) and MBR (Electromagnetic brake interlock) turns off. Contacts must be opened with the EMG stop switch.

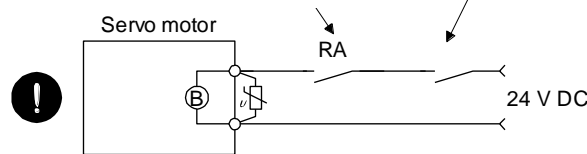

Lock
Refer to section 3.9 when wiring for the circuit configuration.

- When any alarm has occurred, eliminate its cause, ensure safety, and deactivate the alarm before restarting operation.
- Provide an adequate protection to prevent unexpected restart after an instantaneous power failure.

(6) Maintenance, inspection and parts replacement

 CAUTION
<ul style="list-style-type: none"> ● It is recommend that the driver be replaced every 10 years when it is used in general environment.

(7) General instruction

<ul style="list-style-type: none"> ● To illustrate details, the equipment in the diagrams of this Instruction Manual may have been drawn without covers and safety guards. When the equipment is operated, the covers and safety guards must be installed as specified. Operation must be performed in accordance with this Specifications and Instruction Manual.

● DISPOSAL OF WASTE ●

Please dispose a driver, battery (primary battery) and other options according to your local laws and regulations. Please display or notify the final product as necessary.

EEP-ROM life

The number of write times to the EEP-ROM, which stores parameter settings, etc., is limited to 100,000. If the total number of the following operations exceeds 100,000, the driver may malfunction when the EEP-ROM reaches the end of its useful life.

- Write to the EEP-ROM due to parameter setting changes
- Write to the EEP-ROM due to device changes
- Origin setting in absolute position detection system

STO function of the driver

When using the STO function of the driver, refer to chapter 13.

Compliance with global standards

For the compliance with global standards, refer to appendix 4.

«About the manuals»

You must have this Instruction Manual and the following manuals to use this servo. Ensure to prepare them to use the LECSND2-T□ safely.

«Wiring»

Wires mentioned in this Instruction Manual are selected based on the ambient temperature of 40 °C.

«U.S. customary units»

U.S. customary units are not shown in this manual. Convert the values if necessary according to the following table.

Quantity	SI (metric) unit	U.S. customary unit
Mass	1 [kg]	2.2046 [lb]
Length	1 [mm]	0.03937 [in]
Torque	1 [N·m]	141.6 [oz·in]
Moment of inertia	1 [(× 10 ⁻⁴ kg·m ²)]	5.4675 [oz·in ²]
Load (thrust load/axial load)	1 [N]	0.2248 [lbf]
Temperature	N [°C] × 9/5 + 32	N [°F]

CONTENTS

1. FUNCTIONS AND CONFIGURATION	1- 1 to 1-18
1.1 Summary	1-2
1.2 Function block diagram	1-3
1.3 Driver standard specifications	1-6
1.4 Combinations of driver and servo motors	1-7
1.5 Function list	1-8
1.6 Model designation	1-11
1.7 Structure	1-14
1.7.1 Parts identification	1-14
1.8 Installation and removal of network card	1-15
1.9 Configuration including peripheral equipment	1-18
2. INSTALLATION	2- 1 to 2- 7
2.1 Installation direction and clearances	2-3
2.2 Keep out foreign materials	2-5
2.3 Encoder cable stress.....	2-5
2.4 Inspection items	2-5
2.5 Parts having service lives	2-6
2.6 Restrictions when using this product at altitude exceeding 1000 m and up to 2000 m above sea level..	2-7
3. SIGNALS AND WIRING	3- 1 to 3-37
3.1 Input power supply circuit	3-3
3.2 I/O signal connection example	3-6
3.2.1 For sink I/O interface	3-6
3.2.2 For source I/O interface	3-7
3.3 Explanation of power supply system.....	3-8
3.3.1 Signal explanations	3-8
3.3.2 Power-on sequence	3-9
3.3.3 Wiring CNP1, CNP2, and CNP3	3-10
3.4 Connectors and pin assignment	3-12
3.5 Signal (device) explanations	3-14
3.5.1 Input device	3-14
3.5.2 Output device	3-16
3.5.3 Output signal	3-18
3.5.4 Power supply	3-18
3.6 Forced stop deceleration function	3-19
3.6.1 Forced stop deceleration function	3-19
3.6.2 Base circuit shut-off delay time function	3-21
3.6.3 Vertical axis freefall prevention function	3-22
3.6.4 Residual risks of the forced stop function (EM2)	3-22
3.7 Alarm occurrence timing chart	3-23
3.7.1 When you use the forced stop deceleration function	3-23
3.7.2 When you do not use the forced stop deceleration function	3-24
3.8 Interfaces	3-25
3.8.1 Internal connection diagram	3-25

3.8.2 Detailed explanation of interfaces	3-26
3.8.3 Source I/O interfaces	3-28
3.9 Servo motor with a lock.....	3-29
3.9.1 Safety precautions	3-29
3.9.2 Timing chart.....	3-30
3.9.3 Wiring diagrams (LE-□-□ series servo motor)	3-36
3.10 Grounding	3-37

4. STARTUP	4- 1 to 4-17
-------------------	---------------------

4.1 Switching power on for the first time	4-3
4.1.1 Startup procedure	4-3
4.1.2 Wiring check.....	4-4
4.1.3 Surrounding environment.....	4-5
4.2 Startup.....	4-5
4.3 Switch setting and display of the driver.....	4-7
4.3.1 Switches	4-7
4.3.2 Scrolling display	4-8
4.3.3 Status display of an axis	4-10
4.4 Test operation	4-12
4.5 Test operation mode	4-12
4.5.1 Test operation mode in Setup software (MR Configurator2™)	4-13
4.5.2 Motor-less operation in upper side.....	4-17

5. PARAMETERS	5- 1 to 5-102
----------------------	----------------------

5.1 Parameter list	5-2
5.1.1 Basic setting parameters ([Pr. PA_ _]).....	5-3
5.1.2 Gain/filter setting parameters ([Pr. PB_ _])	5-4
5.1.3 Extension setting parameters ([Pr. PC_ _])	5-6
5.1.4 I/O setting parameters ([Pr. PD_ _]).....	5-8
5.1.5 I/O Extension setting 2 parameters ([Pr. PE_ _]).....	5-9
5.1.6 Extension setting 3 parameters ([Pr. PF_ _]).....	5-11
5.1.7 Positioning control parameters ([Pr. PT_ _]).....	5-13
5.1.8 Network setting parameters ([Pr. PN_ _])	5-16
5.2 Detailed list of parameters	5-17
5.2.1 Basic setting parameters ([Pr. PA_ _]).....	5-17
5.2.2 Gain/filter setting parameters ([Pr. PB_ _])	5-31
5.2.3 Extension setting parameters ([Pr. PC_ _])	5-44
5.2.4 I/O setting parameters ([Pr. PD_ _]).....	5-64
5.2.5 Extension setting 2 parameters ([Pr. PE_ _]).....	5-68
5.2.6 Extension setting 3 parameters ([Pr. PF_ _]).....	5-72
5.2.7 Positioning control parameters ([Pr. PT_ _]).....	5-74
5.2.8 Network setting parameters ([Pr. PN_ _])	5-99
5.3 Software limit.....	5-99
5.4 How to set the electronic gear	5-100
5.4.1 Electronic gear setting in the cyclic synchronous mode, profile mode and point table method	5-100
5.4.2 Electronic gear setting in the indexer method.....	5-102

6. NORMAL GAIN ADJUSTMENT	6- 1 to 6-21
----------------------------------	---------------------

6.1 Different adjustment methods	6-2
6.1.1 Adjustment on a single driver	6-2
6.1.2 Adjustment using setup software (MR Configurator2TM)	6-3
6.2 One-touch tuning	6-4
6.2.1 One-touch tuning flowchart	6-5
6.2.2 Display transition and operation procedure of one-touch tuning	6-6
6.2.3 Caution for one-touch tuning	6-11
6.3 Auto tuning	6-12
6.3.1 Auto tuning mode	6-12
6.3.2 Auto tuning mode basis	6-13
6.3.3 Adjustment procedure by auto tuning	6-14
6.3.4 Response level setting in auto tuning mode	6-15
6.4 Manual mode	6-16
6.5 2gain adjustment mode	6-20

7. SPECIAL ADJUSTMENT FUNCTIONS	7- 1 to 7-36
--	---------------------

7.1 Filter setting	7-2
7.1.1 Machine resonance suppression filter	7-2
7.1.2 Adaptive filter II	7-5
7.1.3 Shaft resonance suppression filter	7-7
7.1.4 Low-pass filter	7-8
7.1.5 Advanced vibration suppression control II	7-8
7.1.6 Command notch filter	7-13
7.2 Gain switching function	7-14
7.2.1 Applications	7-14
7.2.2 Function block diagram	7-15
7.2.3 Parameter	7-16
7.2.4 Gain switching procedure	7-19
7.3 Tough drive function	7-23
7.3.1 Vibration tough drive function	7-23
7.3.2 Instantaneous power failure tough drive function	7-25
7.4 Compliance with SEMI-F47 standard	7-29
7.5 Model adaptive control disabled	7-31
7.6 Lost motion compensation function	7-32
7.7 Super trace control	7-35

8. TROUBLESHOOTING	8- 1 to 8- 66
---------------------------	----------------------

8.1 Explanations of the lists	8-2
8.2 Alarm list	8-3
8.3 Warning list	8-11
8.4 Remedies for alarms	8-14
8.5 Remedies for warnings	8-54
8.6 Troubleshooting at power on	8-65
8.7 Trouble which does not trigger an alarm/warning	8-66

9. OUTLINE DRAWINGS	9- 1 to 9-4
----------------------------	--------------------

9.1 Driver	9-2
9.2 Connector	9-4

10. CHARACTERISTICS	10- 1 to 10-8
----------------------------	----------------------

10.1 Overload protection characteristics.....	10-2
10.2 Power supply capacity and generated loss	10-3
10.3 Dynamic lock characteristics.....	10-5
10.3.1 Dynamic lock operation.....	10-5
10.3.2 Permissible load to motor inertia when the dynamic lock is used.....	10-6
10.4 Cable bending life	10-7
10.5 Inrush currents at power-on of main circuit and control circuit	10-8

11. OPTIONS AND PERIPHERAL EQUIPMENT	11- 1 to 11-34
---	-----------------------

11.1 Cable/connector sets	11-2
11.1.1 Combinations of cable/connector sets	11-3
11.1.2 STO cable	11-6
11.1.3 Encoder cable/connector sets.....	11-7
11.1.4 Motor cables.....	11-9
11.1.5 Lock cables	11-10
11.2 Regenerative options	11-11
11.2.1 Combination and regenerative power	11-11
11.2.2 Parameter setting.....	11-11
11.2.3 Selection of regenerative option.....	11-12
11.2.4 Dimensions.....	11-13
11.3 Setup software (MR Configurator2™).....	11-14
11.3.1 Specifications	11-14
11.3.2 System configuration.....	11-15
11.3.3 Precautions for using USB communication function	11-16
11.4 Battery	11-17
11.5 Selection example of wires	11-18
11.6 Molded-case circuit breakers, fuses, magnetic contactors (recommended)	11-20
11.7 Relay (recommended)	11-20
11.8 Noise reduction techniques.....	11-21
11.9 Earth-leakage current breaker	11-29
11.10 EMC filter (recommended).....	11-31

12. ABSOLUTE POSITION DETECTION SYSTEM	12- 1 to 12- 8
---	-----------------------

12.1 Summary	12-2
12.1.1 Features	12-2
12.1.2 Structure.....	12-2
12.1.3 Parameter setting.....	12-2
12.1.4 Confirmation of absolute position detection data	12-3
12.2 Battery.....	12-4
12.3 Battery replacement procedure.....	12-5
12.4 Constructing an absolute position detection system with the upper side that does not use the home position return mode of the driver	12-7
12.4.1 Overview	12-7
12.4.2 Start-up procedure	12-7
12.4.3 Usage precautions and restrictions.....	12-8

13. USING STO FUNCTION	13- 1 to 13-13
-------------------------------	-----------------------

13.1 Introduction	13-2
13.1.1 Summary	13-2
13.1.2 Terms related to safety	13-2
13.1.3 Cautions	13-2
13.1.4 Residual risks of the STO function	13-3
13.1.5 Specifications	13-4
13.1.6 Maintenance	13-5
13.2 STO I/O signal connector (CN8) and signal layouts	13-5
13.2.1 Signal layouts	13-5
13.2.2 Signal (device) explanations	13-6
13.2.3 How to pull out the STO cable	13-6
13.3 Connection example	13-7
13.3.1 Connection example for CN8 connector	13-7
13.3.2 External I/O signal connection example using an MR-J3-D05 safety logic unit of Mitsubishi Electric Corporation	13-8
13.3.3 External I/O signal connection example using an external safety relay unit	13-10
13.4 Detailed description of interfaces	13-11
13.4.1 Sink I/O interface	13-11
13.4.2 Source I/O interface	13-13

14. APPLICATION OF FUNCTIONS	14- 1 to 14- 2
-------------------------------------	-----------------------

14.1 Infinite feed function (setting degree)	14-2
--	------

15. SERVO MOTOR	15- 1 to 15- 6
------------------------	-----------------------

15.1 Servo motor with a lock	15-2
15.1.1 Features	15-2
15.1.2 Characteristics of servo motor with a lock	15-4
15.2 Protection from oil and water	15-5
15.3 Cable	15-5
15.4 Rated speed of servo motor	15-5
15.5 Mounting connectors	15-6

16. HOW TO USE THE POINT TABLE	16- 1 to 16- 30
---------------------------------------	------------------------

16.1 Specification list	16-3
16.2 Switching power on for the first time	16-4
16.3 Switching power on for the first time Point table mode (pt)	16-6
16.3.1 Point table mode (pt)	16-6
16.3.2 Automatic operation using point table	16-6
16.4 Jog mode (jg)	16-24
16.5 Point table setting method	16-26
16.5.1 Point table setting method with Setup software (MR Configurator2TM)	16-26
16.5.2 Point table setting method with objects	16-29

17. HOW TO USE INDEXER	17- 1 to 17- 17
-------------------------------	------------------------

17.1 Specification list	17-3
-------------------------------	------

17.2	Switching power on for the first time	17-4
17.3	Indexer mode (idx)	17-6
17.3.1	Indexer mode (idx)	17-6
17.3.2	Rotation direction specifying indexer	17-7
17.3.3	Shortest rotating indexer operation	17-11
17.4	Jog mode (jg)	17-14
17.4.1	Station JOG operation	17-14
17.4.2	JOG operation	17-16

18. EtherCAT COMMUNICATION

18- 1 to 18- 206

18.1	EtherCAT COMMUNICATION.....	18-3
18.1.1	Summary.....	18-3
18.1.2	Function list.....	18-6
18.1.3	Communication specifications	18-9
18.1.4	Communication specifications	18-10
18.1.4.1	Communication status	18-10
18.1.4.2	EtherCAT state	18-11
18.1.4.3	Startup.....	18-12
18.1.4.4	Network disconnection procedure	18-13
18.1.5	Summary of object dictionary (OD)	18-14
18.1.5.1	Section definition of object dictionary	18-14
18.1.5.2	Saving object dictionary data to EEPROM	18-14
18.2	EtherCAT NETWORK CARD (LEC-S-NE)	18-15
18.2.1	Specifications.....	18-15
18.2.2	Parts identification	18-16
18.2.3	LED indication.....	18-16
18.2.3.1	LED indication definition	18-16
18.2.3.2	LED indication list	18-17
18.2.4	Connecting Ethernet cable.....	18-18
18.3	PDO (PROCESS DATA OBJECT) COMMUNICATION.....	18-19
18.3.1	PDO communication cycle.....	18-19
18.3.2	PDO setting-related object.....	18-19
18.3.3	PDO default mapping	18-20
18.3.4	PDO variable mapping.....	18-22
18.3.5	Mapping-necessary objects	18-23
18.4	SDO (SERVICE DATA OBJECT) COMMUNICATION	18-25
18.4.1	SDO communication-related service	18-25
18.4.2	SDO Abort Code.....	18-26
18.5	CiA 402 DRIVE PROFILE	18-26
18.5.1	FSA state	18-26
18.5.2	Controlword/Control DI	18-29
18.5.2.1	Bit definition of Controlword	18-29
18.5.2.2	Bit definition of Control DI	18-30
18.5.3	Statusword/Status DO	18-32
18.5.3.1	Bit definition of Statusword	18-32
18.5.3.2	Bit definition of Status DO	18-33
18.5.4	Control mode	18-37
18.5.4.1	Selecting control mode (Modes of operation)	18-37
18.5.4.2	Control switching.....	18-37

18.5.4.3	Cyclic synchronous position mode (csp)	18-38
18.5.4.4	Cyclic synchronous velocity mode (csv)	18-41
18.5.4.5	Cyclic synchronous torque mode (cst).....	18-43
18.5.4.6	Profile position mode (pp)	18-45
18.5.4.7	Profile velocity mode (pv).....	18-49
18.5.4.8	Profile torque mode (tq)	18-53
18.5.4.9	Homing mode (hm)	18-56
18.5.4.10	Point table mode (pt).....	18-84
18.5.4.11	Jog mode (jg)	18-89
18.5.4.12	Indexer mode (idx)	18-96
18.5.5	Touch probe.....	18-103
18.5.6	Quick stop	18-107
18.5.7	Halt.....	18-108
18.5.8	Software position limit.....	18-109
18.5.9	Torque limit	18-109
18.5.10	Polarity	18-110
18.5.11	Degree function	18-112
18.5.12	Torque offset.....	18-114
18.6	MANUFACTURER FUNCTIONS	18-115
18.6.1	Object for status monitor.....	18-115
18.6.2	Incremental counter	18-117
18.6.3	Stroke end.....	18-117
18.6.4	Definition of alarm-related objects	18-118
18.6.5	Parameter object	18-119
18.6.5.1	Definition of parameter objects	18-119
18.6.5.2	Enabling parameters.....	18-120
18.6.7	One-touch tuning	18-121
18.6.8	Machine diagnosis function	18-123
18.6.9	Driver life diagnosis function.....	18-124
18.7	OBJECT DICTIONARY	18-125
18.7.1	Store Parameters.....	18-125
18.7.2	Supported object dictionary list.....	18-126
18.7.3	Object dictionary	18-130
18.7.3.1	General Objects	18-130
18.7.3.2	PDO Mapping Objects	18-136
18.7.3.3	Sync Manager Communication Objects	18-140
18.7.3.4	Parameter Objects	18-145
18.7.3.5	Alarm Objects.....	18-148
18.7.3.6	Monitor Objects.....	18-151
18.7.3.7	Manufacturer Specific Control Objects	18-164
18.7.3.8	PDS Control Objects.....	18-175
18.7.3.9	Position Control Function Objects.....	18-179
18.7.3.10	Profile Velocity Mode Objects	18-182
18.7.3.11	Profile Torque Mode Objects	18-184
18.7.3.12	Profile Position Mode Objects.....	18-186
18.7.3.13	Homing Mode Objects	18-190
18.7.3.14	Factor Group Objects.....	18-196
18.7.3.15	Touch Probe Function Objects	18-199
18.7.3.16	Optional application FE Objects	18-200
18.7.3.17	Point Table Mode Objects.....	18-203

19. EtherNet/IP COMMUNICATION	19- 1 to 19- 182
--------------------------------------	-------------------------

19.1	EtherNet/IP COMMUNICATION	19-3
19.1.1	Summary.....	19-3
19.1.2	Function list.....	19-4
19.1.3	Communication specifications	19-6
19.1.4	Establishing and disconnecting the communication	19-7
19.1.4.1	Communication status	19-7
19.1.4.2	Startup.....	19-8
19.1.4.3	Network disconnection procedure	19-9
19.1.5	Summary of object library	19-9
19.1.5.1	Section definition of Drive Configuration Object (64h).....	19-9
19.2	EtherNet/IP NETWORK CARD (LEC-S-N9)	19-10
19.2.1	Specifications.....	19-10
19.2.2	Parts identification	19-10
19.2.3	LED indication.....	19-11
19.2.3.1	LED indication definition	19-11
19.2.3.2	LED indication list	19-11
19.2.4	Connecting Ethernet cables.....	19-12
19.3	I/O COMMUNICATION.....	19-13
19.3.1	I/O communication cycle.....	19-13
19.3.2	I/O communication mapping	19-15
19.4	Explicit Message COMMUNICATION	19-17
19.4.1	Explicit Message communication-related service.....	19-17
19.4.2	Common service.....	19-18
19.4.2.1	Set_Attribute_Single	19-18
19.4.2.2	Get_Attribute_Single.....	19-18
19.4.2.3	Get_Attributes_All	19-18
19.4.2.4	Reset.....	19-19
19.5	DRIVE PROFILE	19-19
19.5.1	FSA state	19-19
19.5.2	Controlword/Control DI	19-22
19.5.2.1	Bit definition of Controlword	19-22
19.5.2.2	Bit definition of Control DI	19-23
19.5.3	Statusword/Status DO	19-26
19.5.3.1	Bit definition of Statusword	19-26
19.5.3.2	Bit definition of Status DO	19-27
19.5.4	Control mode	19-33
19.5.4.1	Selecting control mode (Modes of operation)	19-33
19.5.4.2	Control switching.....	19-33
19.5.4.3	Profile position mode (pp)	19-34
19.5.4.4	Profile velocity mode (pv).....	19-38
19.5.4.5	Profile torque mode (tq)	19-42
19.5.4.6	Homing mode (hm)	19-45
19.5.5	Touch probe.....	19-72
19.5.6	Quick stop	19-76
19.5.7	Halt.....	19-77
19.5.8	Software position limit.....	19-78

19.5.9	Torque limit	19-78
19.5.10	Polarity	19-79
19.5.11	Degree function	19-81
19.6	MANUFACTURER FUNCTIONS	19-83
19.6.1	Object for status monitor.....	19-83
19.6.2	Instruction code	19-85
19.6.2.1	Summary.....	19-85
19.6.2.2	Reading instruction codes.....	19-85
19.6.2.3	Writing instruction code.....	19-86
19.6.2.4	Variable mapping	19-88
19.6.2.5	Respond code	19-89
19.6.3	Stroke end.....	19-90
19.6.4	Definition of alarm-related objects	19-91
19.6.5	Parameter object	19-92
19.6.5.1	Definition of parameter objects	19-92
19.6.5.2	Enabling parameters.....	19-93
19.6.6	One-touch tuning	19-94
19.6.7	Machine diagnosis function	19-96
19.6.8	Driver life diagnosis function.....	19-97
19.6.9	Positioning function by operation start-up signal.....	19-97
19.6.9.1	Summary.....	19-97
19.6.9.2	Specification list	19-97
19.6.9.3	Settings	19-97
19.6.9.4	Status obtainable in the network communication	19-98
19.6.9.5	Operation method	19-99
19.7	OBJECT LIBRARY	19-102
19.7.1	Store Parameters.....	19-102
19.7.2	Supported object library list	19-103
19.7.3	Object library.....	19-107
19.7.3.1	General Objects	19-108
19.7.3.2	Communication Setting Objects.....	19-112
19.7.3.3	Assembly Objects	19-123
19.7.3.4	Parameter Objects (Class ID: 64h).....	19-125
19.7.3.5	Alarm Objects (Class ID: 64h)	19-128
19.7.3.6	Monitor Objects (Class ID: 64h).....	19-132
19.7.3.7	Manufacturer Specific Control Objects (Class ID: 64h)	19-143
19.7.3.8	PDS Control Objects (Class ID: 64h).....	19-155
19.7.3.9	Position Control Function Objects (Class ID: 64h)	19-159
19.7.3.10	Profile Velocity Mode Objects (Class ID: 64h).....	19-162
19.7.3.11	Profile Torque Mode Objects (Class ID: 64h)	19-164
19.7.3.12	Profile Position Mode Objects (Class ID: 64h).....	19-166
19.7.3.13	Homing Mode Objects (Class ID: 64h)	19-171
19.7.3.14	Factor Group Objects.....	19-175
19.7.3.15	Touch Probe Function Objects (Class ID: 64h)	19-178
19.7.3.16	Optional application FE Objects (Class ID: 64h)	19-180

20. PROFINET COMMUNICATION

20- 1 to 20- 176

20.1	PROFINET COMMUNICATION	20-3
20.1.1	Description	20-3

20.1.2	Communication specifications	20-5
20.1.3	Startup	20-6
20.1.4	Network disconnection procedure	20-7
20.1.5	Object dictionary (OD)	20-7
20.1.5.1	Section definition of object dictionary	20-7
20.2	PROFINET NETWORK CARD (LEC-S-NP)	20-8
20.2.1	Specifications.....	20-8
20.2.2	Parts identification	20-8
20.2.3	LED display.....	20-9
20.2.3.1	Network Status LED.....	20-9
20.2.3.2	Card Status LED	20-9
20.2.3.3	Link/Activity LED	20-9
20.2.4	Ethernet cable connection	20-10
20.3	PROCESS DATA (CYCLIC DATA EXCHANGE).....	20-11
20.4	ACYCLIC DATA EXCHANGE	20-15
20.4.1	Acyclic data exchange communication format	20-15
20.4.2	Error number.....	20-16
20.4.3	PROFIdrive parameters (PROFIdrive-specific)	20-16
20.4.3.1	Telegram Selection (P922)	20-17
20.4.3.2	Operating mode (P930)	20-17
20.4.3.3	Fault message counter (P944)	20-17
20.4.3.4	Fault number (P947).....	20-18
20.4.3.5	Drive Unit identification (P964)	20-18
20.4.3.6	Profile identification number (P965)	20-18
20.4.3.7	DO identification (P975).....	20-19
20.4.3.8	Parameter Database Handling and Identification (P980)	20-19
20.4.4	Identification & Maintenance (I&M).....	20-20
20.4.5	Reset To Factory	20-21
20.5	STATE TRANSITION	20-22
20.5.1	Basic State Machine	20-22
20.5.2	FSA state	20-25
20.5.3	Controlword/Statusword	20-27
20.5.3.1	Controlword.....	20-27
20.5.3.2	Statusword.....	20-30
20.6	CONTROL MODE	20-36
20.6.1	Selection of control mode	20-36
20.6.2	Control switching	20-37
20.6.3	Profile position mode (pp).....	20-37
20.6.4	Profile velocity mode (pv)	20-42
20.6.5	Profile torque mode (tq).....	20-48
20.6.6	Homing mode (hm).....	20-51
20.6.7	Point table mode (pt)	20-79
20.6.8	Indexer mode (idx).....	20-84
20.6.9	Jog mode (jg).....	20-91
20.7	WEB SERVER.....	20-97
20.8	MANUFACTURER FUNCTIONS	20-98
20.8.1	PROFIdrive parameters for status monitor.....	20-98
20.8.2	Stroke end	20-100
20.8.3	Software limit	20-101
20.8.4	Torque limit	20-102

20.8.5	Polarity.....	20-103
20.8.6	Touch probe.....	20-104
20.8.7	One-touch tuning	20-109
20.8.8	Driver life diagnosis function.....	20-110
20.8.9	Machine diagnosis	20-111
20.8.10	Quick stop.....	20-112
20.8.11	Halt	20-113
20.8.12	Ramp Stop.....	20-113
20.8.13	PROFIdrive parameter definitions related to alarms	20-114
20.8.14	Parameter	20-115
20.8.14.1	Parameter enabling.....	20-116
20.8.15	Degree function	20-117
20.9	OBJECT DICTIONARY	20-119
20.9.1	Store parameters	20-119
20.9.2	PROFIdrive parameter (Manufacturer-specific) list	20-120
20.9.3	PROFIdrive parameter (Manufacturer-specific)	20-124
20.9.3.1	General Objects	20-124
20.9.3.2	Servo Parameter Objects.....	20-125
20.9.3.3	Alarm Objects.....	20-128
20.9.3.4	Monitor Objects	20-130
20.9.3.5	Manufacturer Specific Control Objects	20-143
20.9.3.6	PDS Control Objects.....	20-151
20.9.3.7	Position Control Function Objects.....	20-154
20.9.3.8	Profile Velocity Mode Objects	20-156
20.9.3.9	Profile Torque Mode Objects	20-158
20.9.3.10	Profile Position Mode Objects.....	20-160
20.9.3.11	Homing Mode Objects	20-164
20.9.3.12	Point Table Mode Objects.....	20-168
20.9.3.13	Factor Group Objects.....	20-171
20.9.3.14	Optional application FE Objects	20-173
20.9.3.15	Touch Probe Function Objects	20-175

APPENDIX	App.- 1 to App.-30
----------	--------------------

App. 1	Peripheral equipment manufacturer (for reference)	App.-2
App. 2	Handling of AC driver batteries for the United Nations Recommendations on the Transport of Dangerous Goods	App.-2
App. 3	Symbol for the new EU Battery Directive	App.-4
App. 4	Compliance with global standards.....	App.-5
App. 4.1	Terms related to safety (IEC 61800-5-2 Stop function)	App.-5
App. 4.2	About safety	App.-5
App. 4.2.1	Professional engineer	App.-5
App. 4.2.2	Applications of the devices	App.-5
App. 4.2.3	Correct use.....	App.-5
App. 4.2.4	General cautions for safety protection and protective measures	App.-8
App. 4.2.5	Residual risk.....	App.-8
App. 4.2.6	Disposal	App.-8
App. 4.2.7	Lithium battery transportation	App.-9
App. 4.3	Mounting/dismounting.....	App.-9
App. 4.4	Electrical Installation and configuration diagram	App.-10



App. 4.5 Signal	App.-11
App. 4.5.1 Signal	App.-11
App. 4.5.2 I/O device	App.-11
App. 4.6 Maintenance and service	App.-12
App. 4.6.1 Inspection items	App.-12
App. 4.6.2 Parts having service lives	App.-13
App. 4.7 Transportation and storage	App.-14
App. 4.8 Technical data	App.-15
App. 4.8.1 LECSND2-T□ driver	App.-15
App. 4.8.2 Driver dimensions	App.-15
App. 4.8.3 Mounting hole	App.-15
App. 4.9 Check list for user documentation	App.-16
App. 5 MR-J3-D05 Safety logic unit of Mitsubishi Electric Corporation	App.-16
App. 5.1 Terms related to safety	App.-16
App. 5.1.1 Stop function for IEC/EN 61800-5-2	App.-16
App. 5.1.2 Emergency operation for IEC/EN 60204-1	App.-16
App. 5.2 Cautions	App.-17
App. 5.3 Residual risk	App.-17
App. 7 Analog monitor	App.-18
App. 8 Encoder output pulse setting method	App.-21
App. 9 Recommended parameter values for each actuator	App.-22

1. FUNCTIONS AND CONFIGURATION

1. FUNCTIONS AND CONFIGURATION	2
1.1 Summary	2
1.2 Function block diagram	3
1.3 Driver standard specifications	6
1.4 Combinations of driver and servo motors	7
1.5 Function list	8
1.6 Model designation	11
1.7 Structure	14
1.7.1 Parts identification	14
1.8 Installation and removal of network card	15
1.9 Configuration including peripheral equipment	18

1. FUNCTIONS AND CONFIGURATION

1. FUNCTIONS AND CONFIGURATION

1.1 Summary



CAUTION ● To ensure safety of the system against unauthorized access via a network, take security measures such as using a firewall.

The LECSND□-T□ series general-purpose AC servo has further higher performance and higher functions compared to the previous LECS□-S□ series.

The LECSND□-T□ series compatible rotary servo motor is equipped with 22-bit (4,194,304 pulses/rev) high-resolution absolute encoder. In addition, speed frequency response is increased to 2.5 kHz. Thus, faster and more accurate control is enabled as compared to the LECS□-S□ series.

With one-touch tuning and real-time auto tuning, you can automatically adjust the servo gains according to the machine.

The tough drive function and the drive recorder function, which are well-received in the LECSA□-S□ series, have been improved. The driver supports the improved functions. Additionally, the preventive maintenance support function detects an error in the machine parts. This function provides strong support for the machine maintenance and inspection.

The LECSND□-T□ driver supports the STO (Safe Torque Off) function. By combining with optional MR-J3-D05 (Mitsubishi Electric), the driver supports SS1 (Safe stop 1) function.

The driver has a USB communication interface. Therefore, you can connect the driver to the personal computer with Setup software (MR Configurator2™) installed to perform the parameter setting, test operation, gain adjustment, and others.

The following shows compatible networks. Prepare a network card (LEC-S-N□).

Network	Network card
EtherCAT	LEC-S-NE
EtherNet/IP	LEC-S-N9
PROFINET	LEC-S-NP

1. FUNCTIONS AND CONFIGURATION

1.2 Function block diagram

The function block diagram of this servo is shown below.

(1) LECSND2-T5, T7, T8

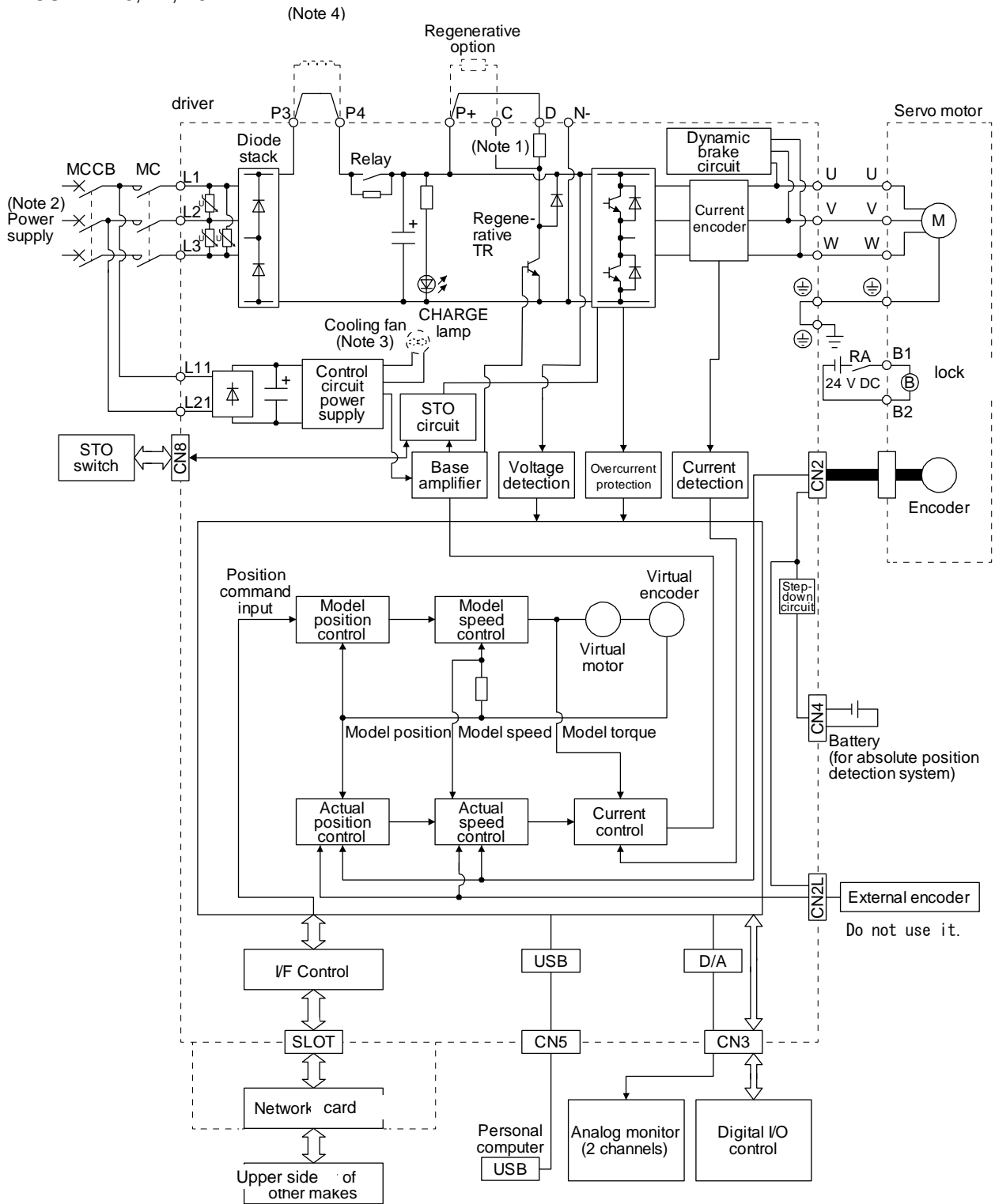

1. FUNCTIONS AND CONFIGURATION

- Note
1. The built-in regenerative resistor is not provided for LECSND2-T5.
 2. For 1-phase 200 V AC to 240 V AC, connect the power supply to L1 and L3. Leave L2 open. For the power supply specifications, refer to section 1.3.
 3. Drivers LECSND2-T9 or more have a cooling fan.
 4. short P3 and P4.

1. FUNCTIONS AND CONFIGURATION

(2) LECSND2-T9

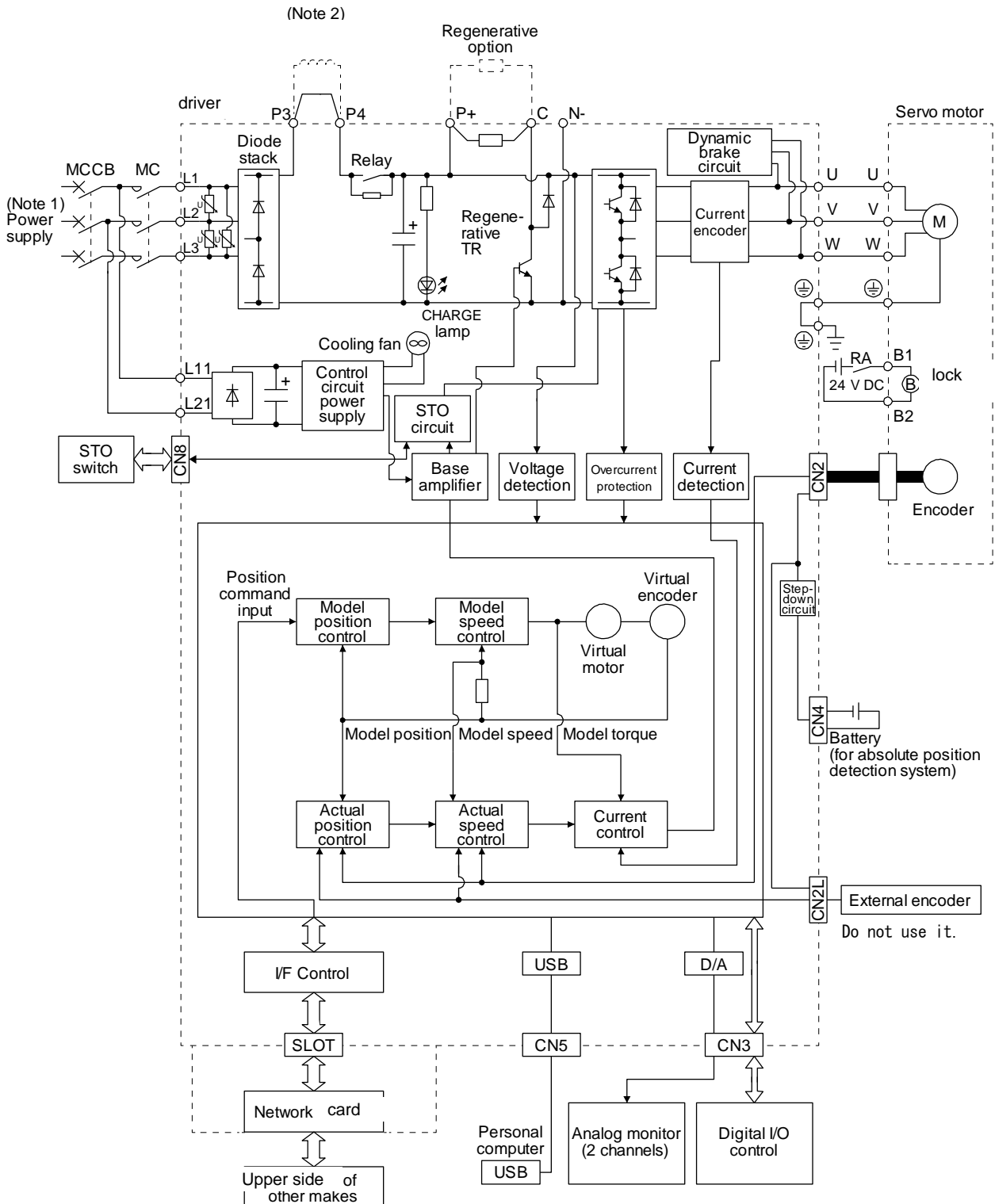

Note 1. Refer to section 1.3 for the power supply specifications.

2. short P3 and P4.

1. FUNCTIONS AND CONFIGURATION

1.3 Driver standard specifications

Model: LECSND2-T□		5	7	8	9	
Output	Rated voltage	3-phase 170 V AC				
	Rated current [A]	1.1	1.5	2.8	5.8	
	Output frequency	Less than 590 Hz				
	Output frequency accuracy	±0.01%				
Main circuit power supply	Voltage/Frequency (Note 12)	3-phase or 1-phase 200 V AC to 240 V AC, 50 Hz/60 Hz				
	Rated current [A]	0.9	1.5	2.6	3.8	
	Permissible voltage fluctuation (Note 12)	3-phase or 1-phase 170 V AC to 264 V AC				
	Permissible frequency fluctuation	Within ±5%				
	Power supply capacity [kVA]	Refer to section 10.2.				
	Inrush current [A]	Refer to section 10.5.				
Control circuit power supply	Voltage/Frequency	1-phase 200 V AC to 240 V AC, 50 Hz/60 Hz				
	Rated current [A]	0.2				
	Permissible voltage fluctuation	1-phase 170 V AC to 264 V AC				
	Permissible frequency fluctuation	Within ±5%				
	Power consumption [W]	30				
	Inrush current [A]	Refer to section 10.5.				
Interface power supply	Voltage	24 V DC ± 10%				
	Current capacity [A]	(Note 1) 0.3 (including CN8 connector signals)				
Control method	Sine-wave PWM control, current control method					
Dynamic brake	Built-in					
Communication function	USB: connection to a personal computer or others (setup software (MR Configurator2™)-compatible)					
Encoder output pulses	Compatible (A/B/Z-phase pulse)					
Analog monitor	Two channels					
Protective functions	Overcurrent shut-off, regenerative overvoltage shut-off, overload shut-off (electronic thermal), servo motor overheat protection, encoder error protection, regenerative error protection, undervoltage protection, instantaneous power failure protection, overspeed protection, error excessive protection					
Safety function	STO (IEC/EN 61800-5-2)					
Safety performance	Standards certified by CB	EN ISO 13849-1 category 3 PL e, EN 61508 SIL 3, EN 62061 SIL CL 3, and EN 61800-5-2				
	Response performance	8 ms or less (STO input off → energy shut off)				
	(Note 3) Test pulse input (STO)	Test pulse interval: 1 Hz to 25 Hz Test pulse off time: Up to 1 ms				
	Mean time to dangerous failure (MTTFd)	MTTFd ≥ 100 [years]				
	Diagnosis coverage (DC)	DC = Medium, 97.6 [%]				
	Average probability of dangerous failures per hour (PFH)	PFH = 6.4 × 10 ⁻⁹ [1/h]				
Compliance to global standards	CE marking	LVD: EN 61800-5-1 EMC: EN 61800-3 MD: EN ISO 13849-1, EN 61800-5-2, EN 62061				
	UL standard (Note 11)	UL 508C				
Structure (IP rating)	Natural cooling, open (IP20)			Force cooling, open (IP20)		
Close mounting (Note 2)	Possible					
Environment	Ambient temperature	Operation	0 °C to 55 °C (non-freezing)			
		Storage	-20 °C to 65 °C (non-freezing)			
	Ambient humidity	Operation	5% to 90 %RH (non-condensing)			
		Storage				
	Ambience	Indoors (no direct sunlight), free from corrosive gas, flammable gas, oil mist, dust, and dirt				
	Altitude	2000 m or less above sea level(note7)				
Vibration resistance	5.9 m/s ² , at 10 Hz to 55 Hz (directions of X, Y and Z axes)					
Mass [kg]	1.0			1.4		

1. FUNCTIONS AND CONFIGURATION

- Note
1. 0.3 A is the value applicable when all I/O signals are used. The current capacity can be decreased by reducing the number of I/O points.
 2. When closely mounting the drivers, operate them at the ambient temperature of 0 °C to 45 °C or at 75% or smaller effective load ratio.
 3. Test pulse is a signal which instantaneously turns off a signal to the driver at a constant period for external circuit to self-diagnose.
 4. Except for the terminal block.
 5. This value is applicable when a 3-phase power supply is used.
 7. When using 1-phase 200 V AC to 240 V AC power supply, operate the driver at 75% or smaller effective load ratio.
 9. Follow the restrictions in section 2.6 when using this product at altitude exceeding 1000 m and up to 2000 m above sea level.
 10. The safety level depends on the setting value of [Pr. PF18 STO diagnosis error detection time] and whether STO input diagnosis by TOFB output is performed or not. For details, refer to the Function column of [Pr. PF18] in section 5.2.6.
 11. The driver product (without network card) is UL compliant.
 12. The driver will be damaged if 3-phase 400V AC is applied.

1.4 Combinations of driver and servo motors

Driver	Servo motor
	LE-□-□
LECSND□-T5	T5, T6
LECSND□-T7	T7
LECSND□-T8	T8
LECSND2-T9	T9

1. FUNCTIONS AND CONFIGURATION

1.5 Function list

The following table lists the functions of this servo. For details of the functions, refer to each section of the detailed description field.

POINT
<p>● Symbols in the network column indicate the following networks.</p> <p>ECT: EtherCAT EIP: EtherNet/IP PNT: PROFINET</p>

Function	Description	Network			Detailed explanation
		ECT	EIP	PNT	
Cyclic synchronous position mode (csp)	The position control operation performed by a synchronous sequential position command through network is supported.	○	/	/	(Note)
Cyclic synchronous velocity mode (csv)	The speed control operation performed by a synchronous sequential speed command through network is supported.	○	/	/	
Cyclic synchronous torque mode (cst)	The torque control operation performed by a synchronous sequential torque command through network is supported.	○	/	/	
Profile position mode (pp)	The positioning operation performed by an asynchronous end position command through network is supported.	○	○	○	
Profile velocity mode (pv)	The speed control operation performed by an asynchronous speed command through network is supported.	○	○	○	
Profile torque mode (tq)	The torque control operation performed by an asynchronous torque command through network is supported.	○	○	○	
Homing mode (hm)	The home position return operation specified in each network is supported.	○	○	○	
Point table mode (pt)	Set 1 to 255 point tables in advance, and select any point table to perform operation in accordance with the set values. This is available with drivers with software version B2 or later.	○	/	○	Chapter 16
Indexer mode (idx)	Set the station positions divided into 2 to 255 in advance to perform operation to the station positions. This is available with drivers with software version B2 or later.	○	/	○	Chapter 17
Jog mode (jg)	This is a control mode where the servo motor speed is set to drive the servo motor manually. This is available with drivers with software version B2 or later.	○	/	○	Chapter 16, Chapter 17
Model adaptive control	This function achieves a high response and stable control following the ideal model. The two-degrees-of-freedom model adaptive control enables you to set a response to the command and response to the disturbance separately. Additionally, this function can be disabled. Refer to section 7.5 for disabling this function.	○	○	○	/
Touch probe	When the touch probe signal turns on, the current position is latched.	○	○	○	Section 3.5 (2) [Pr. PD37] (Note)
High-resolution encoder	High-resolution encoder of 4194304 pulses/rev is used for the encoder of the rotary servo motor compatible with the MELSERVO-J4 series.	○	○	○	/
Absolute position detection system	Setting a home position once makes home position return unnecessary at every power-on.	○	○	○	Chapter 12
Gain switching function	You can switch gains during rotation/stop, and can use input devices to switch gains during operation.	○	○	○	Section 7.2
Advanced vibration suppression control II	This function suppresses vibration at an arm end or residual vibration.	○	○	○	Section 7.1.5
Machine resonance suppression filter	This filter function (notch filter) decreases the gain of the specific frequency to suppress the resonance of the mechanical system.	○	○	○	Section 7.1.1
Shaft resonance suppression filter	When a load is mounted to the servo motor shaft, resonance by shaft torsion during driving may generate a mechanical vibration at high frequency. The shaft resonance suppression filter suppresses the vibration.	○	○	○	Section 7.1.3
Adaptive filter II	The driver detects mechanical resonance and sets filter characteristics automatically to suppress mechanical vibration.	○	○	○	Section 7.1.2
Low-pass filter	Suppresses high-frequency resonance which occurs as the servo system response is increased.	○	○	○	Section 7.1.4

1. FUNCTIONS AND CONFIGURATION

Function	Description	Network			Detailed explanation
		ECT	EIP	PNT	
Machine analyzer function	Analyzes the frequency characteristic of the mechanical system by simply connecting an Setup software (MR Configurator2™) installed personal computer and the driver. Setup software (MR Configurator2™) is necessary for this function.	○	○	○	
Robust filter	For roll feed axis, etc. of which a response level cannot be increased because of the large load to motor inertia ratio, this function improves a disturbance response.	○	○	○	[Pr. PE41]
Slight vibration suppression control	This function suppresses vibration of ±1 pulse generated at a servo motor stop.	○	○	○	[Pr. PB24]
Electronic gear	Positioning control is performed with the value obtained by multiplying the position command from the upper side by a set electronic gear ratio.	○	○	○	[Pr. PA06] [Pr. PA07]
S-pattern acceleration/deceleration time constant	Speed can be increased and decreased smoothly.	○	○	○	[Pr. PT51]
Auto tuning	Automatically adjusts the gain to optimum value if load applied to the servo motor shaft varies.	○	○	○	Section 6.3
Regenerative option	Use a regenerative option when the built-in regenerative resistor of the driver does not have sufficient regenerative capacity for a large regenerative power generated.	○	○	○	Section 11.2
Alarm history clear	Clears alarm histories.	○	○	○	[Pr. PC21]
Input signal selection (device settings)	The input devices including LSP (forward rotation stroke end) and LSN (reverse rotation stroke end) can be assigned to certain pins of the CN3 connector.	○	○	○	[Pr. PD03] to [Pr. PD05]
Output signal selection (device settings)	The output devices including MBR (Electromagnetic brake interlock) can be assigned to certain pins of the CN3 connector.	○	○	○	[Pr. PD07] to [Pr. PD09]
Output signal (DO) forced output	Turns on/off the output signals forcibly independently of the servo status. Use this function for checking output signal wiring, etc.	○	○	○	Section 4.5.1 (1) (d)
Torque limit	Limits the servo motor torque.	○	○	○	[Pr. PA11] [Pr. PA12]
Speed limit	The servo motor speed can be limited.	○	○	○	[Pr. PT67]
Status display	Shows servo status on the 3-digit, 7-segment LED display.	○	○	○	Section 4.3
Test operation mode	JOG operation, positioning operation, motor-less operation, DO forced output, program operation and single-step feed Setup software (MR Configurator2™) is necessary for this function.	○	○	○	Section 4.5
Analog monitor output	Outputs servo status with voltage in real time.	○	○	○	[Pr. PC09] [Pr. PC10]
Setup software (MR Configurator2™)	Using a personal computer, you can perform the parameter setting, test operation, monitoring, and others.	○	○	○	Section 11.7
One-touch tuning	Gain adjustment is performed just by one click a certain button on Setup software (MR Configurator2™). Also, one-touch tuning can be performed via a network. For details, refer to respective communication method manuals of "MR-J4- TM_ Driver Instruction Manual".	○	○	○	Section 6.2
SEMI-F47 function	This function enables to avoid triggering [AL. 10 Undervoltage] using the electrical energy charged in the capacitor in case that an instantaneous power failure occurs during operation. Use a 3-phase for the input power supply of the driver. Using a 1-phase 100 V AC/200 V AC for the input power supply will not comply with SEMI-F47 standard.	○	○	○	[Pr. PA20] [Pr. PF25] Section 7.4
Tough drive function	This function makes the equipment continue operating even under the condition that an alarm occurs. The tough drive function includes two types: the vibration tough drive and the instantaneous power failure tough drive.	○	○	○	Section 7.3
Drive recorder function	This function continuously monitors the servo status and records the status transition before and after an alarm for a fixed period of time. You can check the recorded data on the drive recorder window of Setup software (MR Configurator2™) by clicking the "Graph" button. However, the drive recorder is not available when: 1. You are using the graph function of Setup software (MR Configurator2™). 2. You are using the machine analyzer function. 3. [Pr. PF21] is set to "-1". 4. The upper side is not connected (except the test operation mode). 5. An alarm related to the upper side has occurred.	○	○	○	[Pr. PA23]

1. FUNCTIONS AND CONFIGURATION

Function	Description	Network			Detailed explanation
		ECT	EIP	PNT	
STO function	This amplifier complies with the STO function as functional safety of IEC/EN 61800-5-2. You can create a safety system for the equipment easily.	<input type="radio"/>	<input type="radio"/>	<input type="radio"/>	Chapter 13
Driver life diagnosis function	You can check the cumulative energization time and the number of on/off times of the inrush relay. This function gives an indication of the replacement time for parts of the driver including a capacitor and a relay before they malfunction. Setup software (MR Configurator2™) is necessary for this function. Also, the driver life diagnosis function can be used via a network. For details, refer to respective communication method manuals of "MR-J4-_TM_ Driver Instruction Manual".	<input type="radio"/>	<input type="radio"/>	<input type="radio"/>	
Power monitoring function	This function calculates the power running energy and the regenerative power from the data in the driver such as speed and current. Power consumption and others are displayed on Setup software (MR Configurator2™). Also, the power monitoring function can be used via a network. For details, refer to respective communication method manuals of "MR-J4-_TM_ Driver Instruction Manual".	<input type="radio"/>	<input type="radio"/>	<input type="radio"/>	
Machine diagnosis function	From the data in the driver, this function estimates the friction and vibrational component of the drive system in the equipment and recognizes an error in the machine parts, including a ball screw and bearing. Setup software (MR Configurator2™) is necessary for this function. Also, the machine diagnosis function can be used via a network. For details, refer to respective communication method manuals of "MR-J4-_TM_ Driver Instruction Manual".	<input type="radio"/>	<input type="radio"/>	<input type="radio"/>	
Lost motion compensation function	This function improves the response delay generated when the machine moving direction is reversed.	<input type="radio"/>	<input type="radio"/>	<input type="radio"/>	Section 7.6
Super trace control	This function sets constant and uniform acceleration/deceleration droop pulses to almost 0.	<input type="radio"/>	<input type="radio"/>	<input type="radio"/>	Section 7.7
Superimposed synchronous control function	This function drives the servo motor by using externally input pulses as the master.		<input type="radio"/>		(Note)
Positioning function by operation start-up signal	This function starts positioning with an input signal.		<input type="radio"/>		(Note)
FoE (File Access over EtherCAT)	This driver supports FoE (File Access over EtherCAT). For details, contact your local sales office. This is used with drivers with software version B3 or later.	<input type="radio"/>			
Infinite feed function (setting degree)	When the unit of position data is set to degree in the profile mode, the detection of [AL. E3.1 Multi-revolution counter travel distance excess warning] is disabled and the home position is retained even if the servo motor rotates 32768 revolutions or more are in the same direction. Thus, the current position is restored after the power is cycled. This function can be used with the absolute position detection system. This is available with drivers with software version B0 or later.	<input type="radio"/>	<input type="radio"/>	<input type="radio"/>	Section 14

Note. For details, refer to chapter 18,19,20..

(Note)

The firmware version of the LECSND2-T□ driver is "C1" regardless of the type of network card used.

The firmware version of the LECSND2-T□ driver can be checked using the setup software (MR Configurator2™).

(Diagnosis → System Configuration → Servo Amplifier S/W No.)

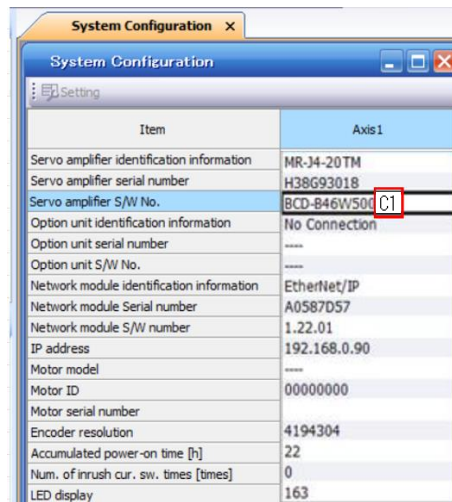

1. FUNCTIONS AND CONFIGURATION

1.6 Model designation (1) Rating plate

LECSND 2 - T5

Driver type

Motor type

ND	Network card type (Absolute encoder)
----	---

	Type	Capacity	Encoder
T5	AC Servo motor (T6) *1	100W	Absolute
T7	AC Servo motor (T7) *1	200W	
T8	AC Servo motor (T8) *1	400W	
T9	AC Servo motor (T9) *1	750W	

Power supply

2	AC200V~AC240V 50/60Hz
---	-----------------------

*1 This is a symbol of motor type (actuator part).

* If I/O connector(CN1) is required, order the part number "LE-CSNS" separately.

* If I/O cable(CN1) is required, order the part number "LEC-CSNS-1" separately.

(2) Option Model

a) Motor cable / Lock cable / Encoder cable

LE - CSM - S5A

Motor Type

S	AC Servo motor
---	----------------

Cable Content

M	Motor cable
B	Lock cable
E	Encoder cable

Connector Direction

A	Axis side
B	Opposite axis side

Cable Length (L) [m]

2	2m
5	5m
A	10m

Cable Type

S	Standard cable
R	Robot cable

1. FUNCTIONS AND CONFIGURATION

b) I/O Connector (For LECSND□-T□)

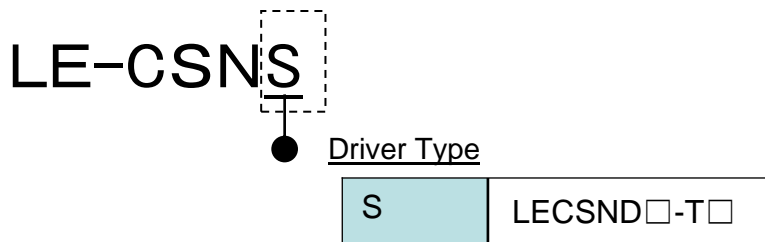

*LE-CSNS is 10120-3000PE (Connector)/ 10320-52F0-008 (Shell kit) of Sumitomo 3M Limited or equivalent goods.
Applicable wire size: AWG24~30

c) Regenerative options

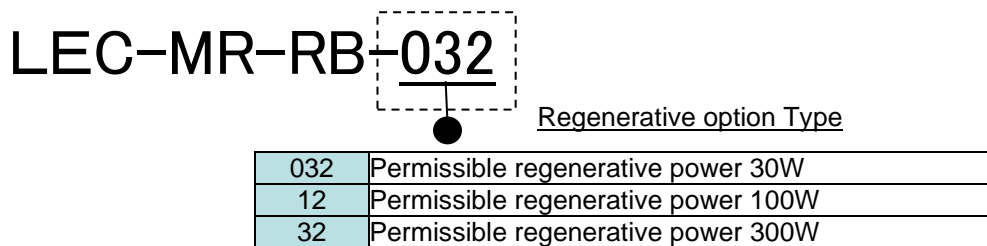

*MR-RB□ of Mitsubishi Electric Corporation.

d) Setup software (MR Configurator2™)

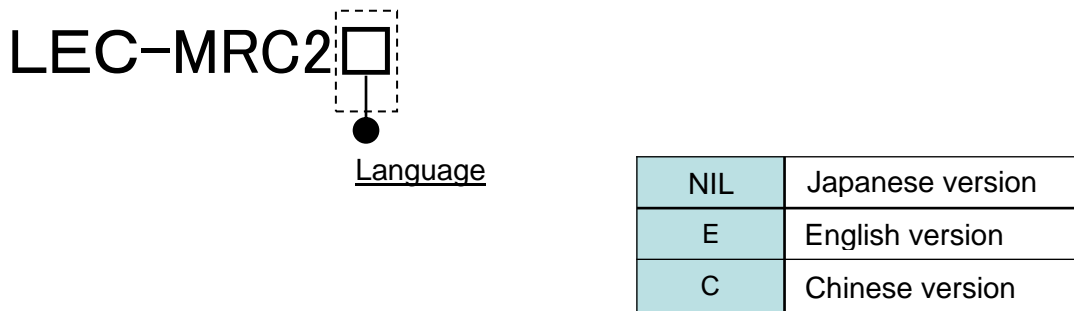

* SW1DNc-MRC2-J of Mitsubishi Electric Corporation.
Refer to the website of Mitsubishi Electric Corporation for the information of the operating environment and upgrading. Order USB cable separately.

*LECSND2-T□ cannot be used by LEC-MR-SETUP221□.

e) USB cable(3m)

LEC-MR-J3USB

* MR-J3USBCBL3M of Mitsubishi Electric Corporation.

f) Battery

Please purchase replacement battery from Mitsubishi Electric Corporation.
Mitsubishi Electric Corporation product number: MR-BAT6V1SET-A

Absolute position data is maintained by installing the battery to the driver.

1. FUNCTIONS AND CONFIGURATION

g) STO cable(3m)

LEC-MR-D05UDL3M

* MR-D05UDL3M-B of Mitsubishi Electric Corporation.
It is a cable that connects the driver with the equipment when the safety function is used.
Do not use other cables.

h) I/O Connector

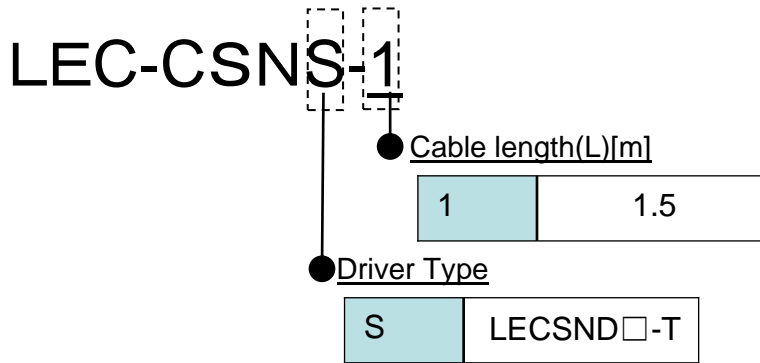

*LEC-CSNS-1 is 10120-3000PE (Connector)/ 10320-52F0-008 (Shell kit) of Sumitomo 3M Limited or equivalent goods.

*Conductor size:AWG24

Wiring

LEC-CSNS-1: Pin nos. 1 to 20

Connector pin no.	Pair no. of wire	Insulation color	Dot mark	Dot color	Connector pin no.	Pair no. of wire	Insulation color	Dot mark	Dot color	
A side	1	Orange	■	Red	A side	19	10	■ ■	Red	
	2		■	Black		20			■ ■	Black
	3	Light gray	■	Red						
	4		■	Black						
	5	White	■	Red						
	6		■	Black						
	7	Yellow	■	Red						
	8		■	Black						
	9	Pink	■	Red						
	10		■	Black						
	11	Orange	■ ■	Red						
	12		■ ■	Black						
	13	Light gray	■ ■	Red						
	14		■ ■	Black						
	15	White	■ ■	Red						
	16		■ ■	Black						
	17	Yellow	■ ■	Red						
	18		■ ■	Black						

i) Network card type (for LECSND□-T□)

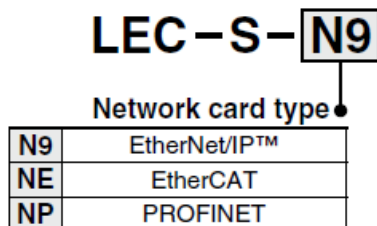

1. FUNCTIONS AND CONFIGURATION

1.7 Structure

1.7.1 Parts identification

(1) LECSND2-T□

The diagram is for LECSND2-T5

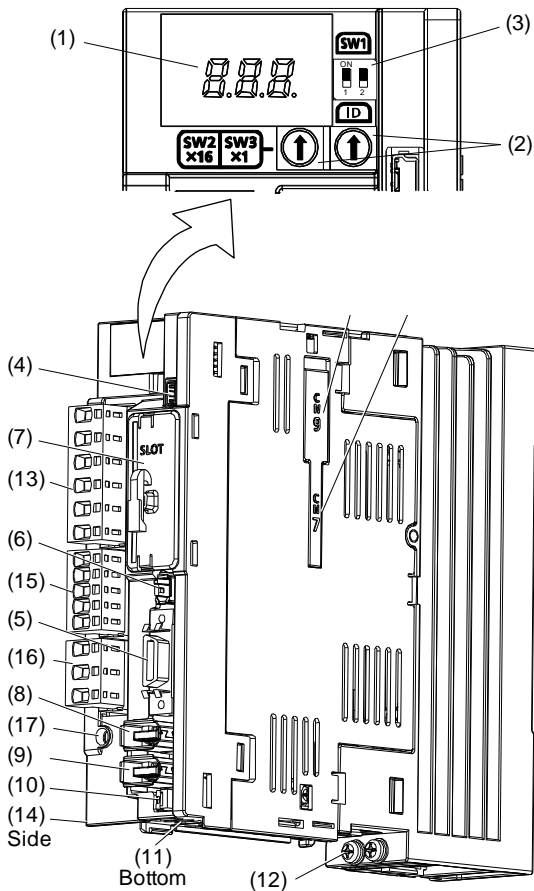

No.	Name/Application	Detailed explanation
(1)	Display The 3-digit, 7-segment LED shows the servo status and the alarm number.	
(2)	Axis selection rotary switch (SW2/SW3) Used to set the axis No. of driver.	Section 4.3
(3)	Mode select switch (SW1) Set the test operation mode. (SW1-1)	
(4)	USB communication connector (CN5) Connect with the personal computer.	Section 11.7
(5)	I/O signal connector (CN3) Used to connect digital I/O signals.	Section 3.2 Section 3.4
(6)	STO input signal connector (CN8) Used to connect MR-J3-D05 safety logic unit and external safety relay.	Chapter 13 App. 5
(7)	Network card slot (SLOT) Insert the network card. (Note) Do not discard the open tool attached to the cover.	Section 1.7.3
(8)	Encoder connector (CN2) Used to connect the servo motor encoder.	
(9)	External encoder connector (CN2L) Do not use it.	
(10)	Battery connector (CN4) Used to connect the battery for absolute position data backup.	Chapter 12
(11)	Battery holder Install the battery for absolute position data backup.	Section 12.2
(12)	Protective earth (PE) terminal	Section 3.1 Section 3.3
(13)	Main circuit power connector (CNP1) Connect the input power supply.	
(14)	Rating plate	Section 1.6
(15)	Control circuit power connector (CNP2) Connect the control circuit power supply and regenerative option.	Section 3.1 Section 3.3
(16)	Servo motor power output connector (CNP3) Connect the servo motor.	
(17)	Charge lamp When the main circuit is charged, this will light. While this lamp is lit, do not reconnect the cables.	

1. FUNCTIONS AND CONFIGURATION

1.8 Installation and removal of network card



WARNING

- Before installing or removing network card, turn off the power and wait for 15 minutes or more until the charge lamp turns off. Then, confirm that the voltage between P+ and N- is safe with a voltage tester and others. Otherwise, an electric shock may occur. In addition, when confirming whether the charge lamp is off or not, always confirm it from the front of the driver.



CAUTION

- Avoid installing and removing the network card repeatedly. Any contact failure of the connector may be caused.

POINT

- The internal circuits of the driver and the network card may be damaged by static electricity. Always take the following precautions.
 - Ground human body and work bench.
 - Do not touch the conductive areas, such as connector pins and electrical parts, directly by hand.

1. FUNCTIONS AND CONFIGURATION

(1) Installation of network card

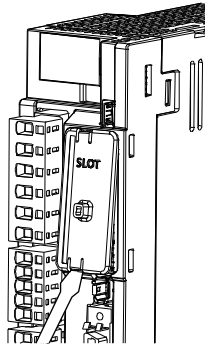

- 1) Remove the slot cover with a flat-blade screwdriver, etc. Make sure to store the removed cover.

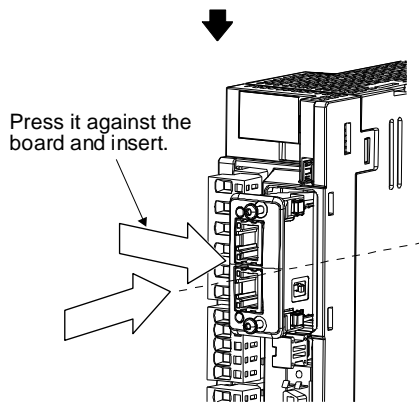

- 2) Press the network card against the board on the right side so as to align with the guide in the driver, and insert it along the board. Forcibly inserting it all the way in obliquely without aligning with the guide may break the board and the network card.

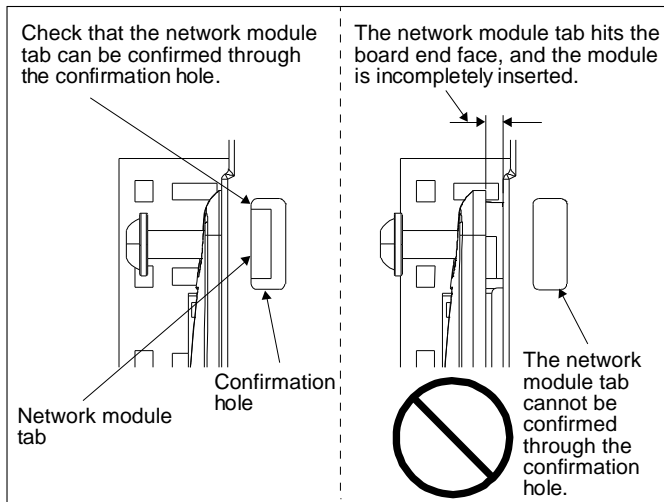

- 3) Check if the network card tabs can be confirmed through the confirmation hole on the side of the driver as shown in the diagram. If the tabs cannot be confirmed, insert the network card while pressing it since the tabs hit the board end face, and the card is incompletely inserted.

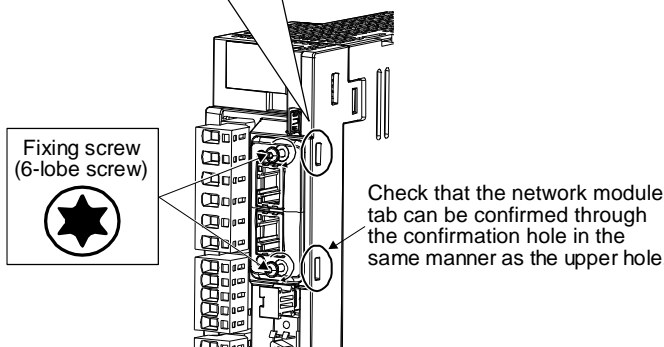

- 4) Tighten the fixing screws using a #8 6-lobe driver. Tightening torque is 0.25 N•m.

1. FUNCTIONS AND CONFIGURATION

(2) Removal of network card

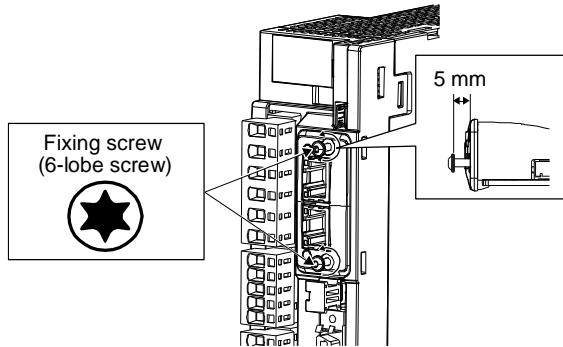

- 1) Loosen two screws fixing the network card approximately 5 mm using the #8 6-lobe driver.

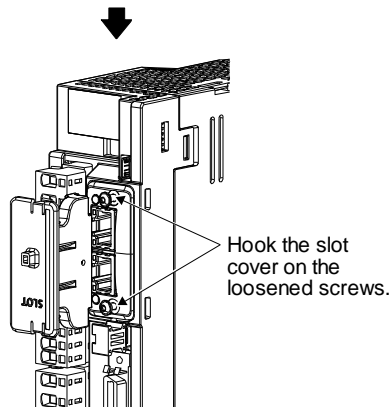

- 2) Hook the slot cover included at product shipment on the loosened screws as shown in the diagram.

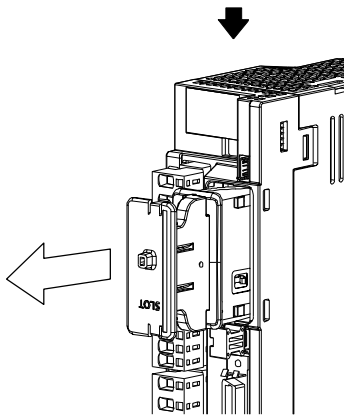

- 3) Hold the slot cover, and pull it straight toward you to remove the network card.

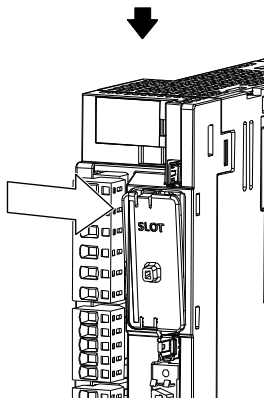

- 4) Fit the slot cover to prevent dust from entering it.

1. FUNCTIONS AND CONFIGURATION

1.9 Configuration including peripheral equipment



CAUTION ●Connecting a servo motor of the wrong axis to U, V, W, or CN2 of the driver may cause a malfunction.

POINT

●Equipment other than the driver and servo motor are optional or recommended products.

(1) LECSND2-T□

The diagram shows LECSND2-T7.

Caution: The driver will be damaged if 3-phase 400V AC is applied.

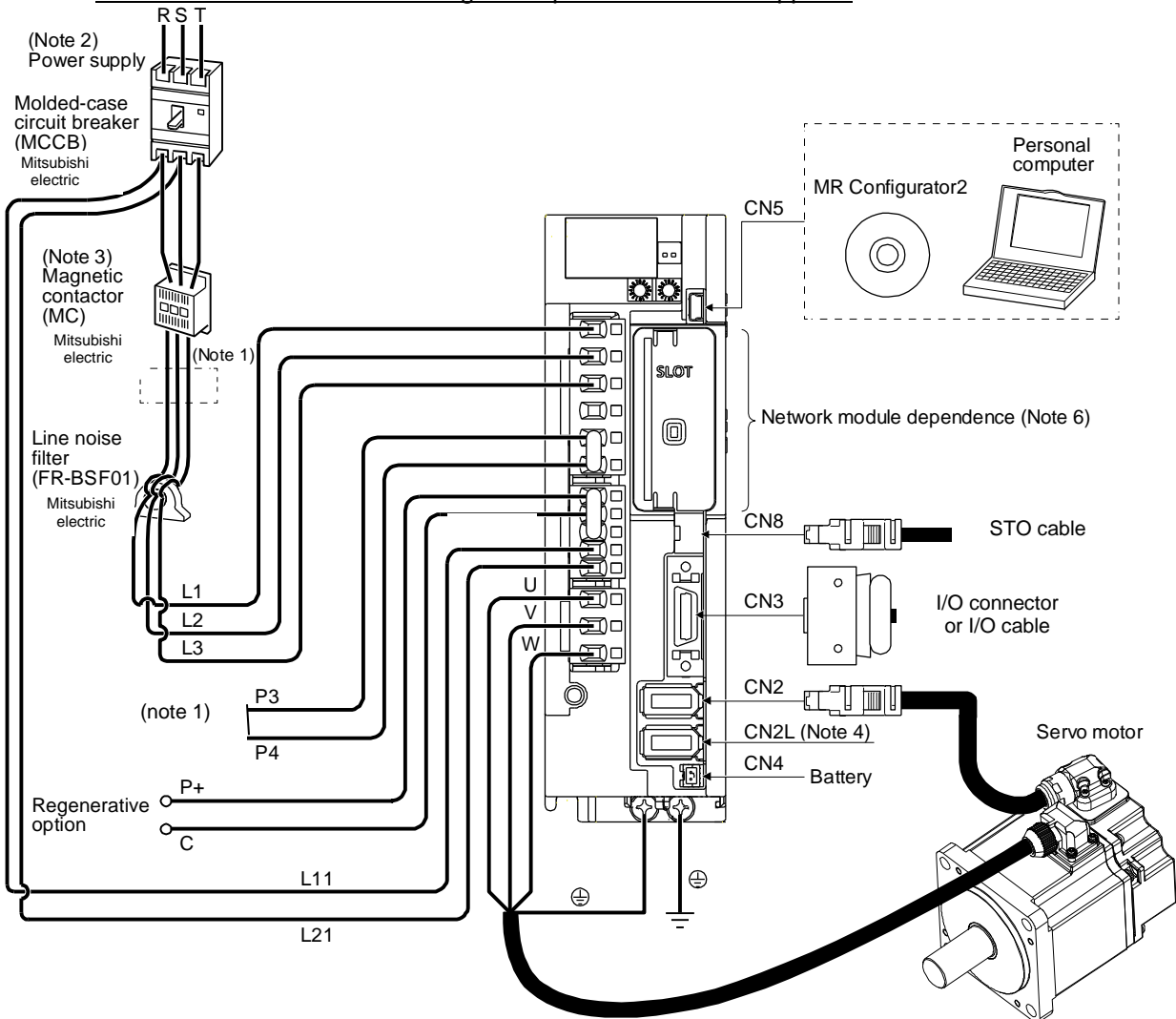

Note 1. short P3 and P4.

2. For 1-phase 200 V AC to 240 V AC, connect the power supply to L1 and L3. Leave L2 open. Refer to section 1.3 for the power supply specifications.
3. Depending on the main circuit voltage and operation pattern, bus voltage decreases, and that may cause the forced stop deceleration to shift to the dynamic brake deceleration. When dynamic brake deceleration is not required, slow the time to turn off the magnetic contactor.
4. CN2L cannot be used. Connect the encoder cable to CN2.
5. Always connect between P+ and D terminals. When using the regenerative option, refer to section 11.2.
6. For the network card connections, refer to chapter 18,19,20

2. INSTALLATION

2. INSTALLATION	2
2.1 Installation direction and clearances	3
2.2 Keep out foreign materials	5
2.3 Encoder cable stress.....	5
2.4 Inspection items	5
2.5 Parts having service lives	6
2.6 Restrictions when using this product at altitude exceeding 1000 m and up to 2000 m above sea level.	7

2. INSTALLATION

2. INSTALLATION

 **WARNING** ● To prevent electric shock, ground each equipment securely.

 **CAUTION**

- Stacking in excess of the specified number of product packages is not allowed.
- Do not hold the front cover, cable, or connector when carrying the driver. It may fall.
- Install the equipment on incombustible material. Installing it directly or close to combustibles will lead to a fire.
- Install the driver and the servo motor in a load-bearing place in accordance with this manual.
- Do not get on or put heavy load on the equipment. Otherwise, it may cause injury.
- Use the equipment within the specified environment. For the environment, refer to section 1.3.
- Provide an adequate protection to prevent screws and other conductive matter, oil and other combustible matter from entering the driver.
- Do not block the intake and exhaust areas of the driver. Otherwise, it may cause a malfunction.
- Do not drop or strike the driver. Isolate it from all impact loads.
- Do not install or operate the driver which have been damaged or have any parts missing.
- When the equipment has been stored for an extended period of time, contact your local sales office.
- When handling the driver, be careful about the edged parts such as corners of the driver.
- The driver must be installed in the metal cabinet.

2. INSTALLATION

2.1 Installation direction and clearances



CAUTION

- The equipment must be installed in the specified direction. Otherwise, it may cause a malfunction.
- Leave specified clearances between the driver and the cabinet walls or other equipment. Otherwise, it may cause a malfunction.

(1) Installation clearances of the driver

(a) Installation of one driver

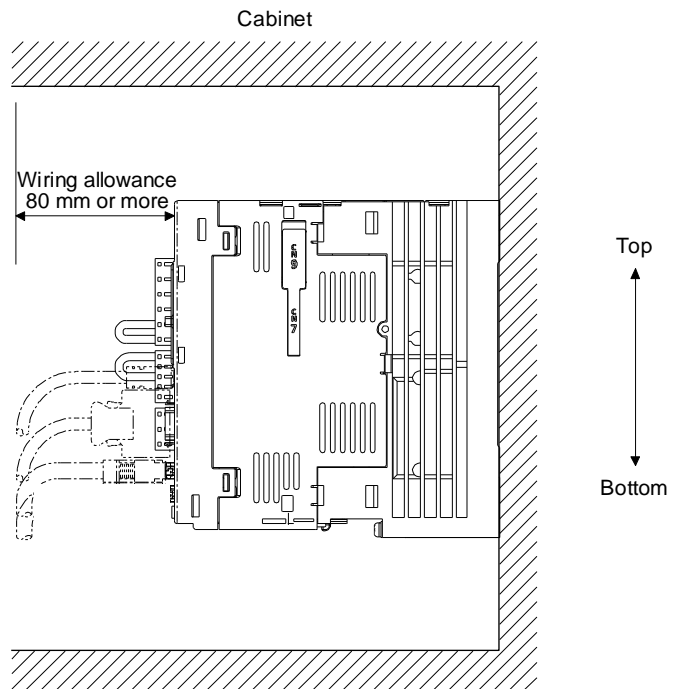
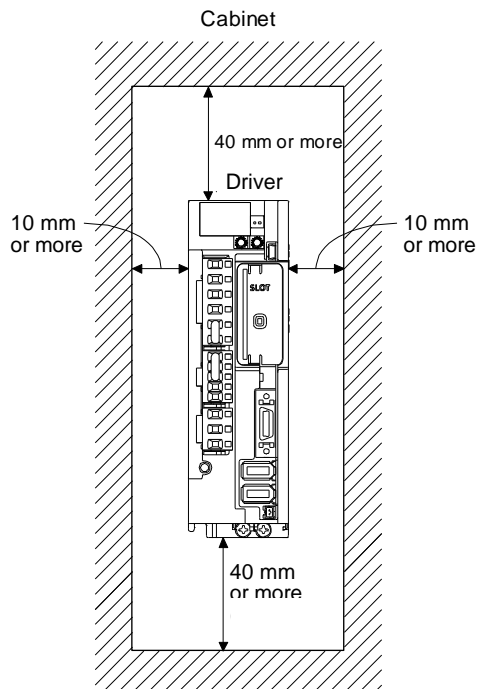

2. INSTALLATION

(b) Installation of two or more drivers

POINT

- Close mounting is possible depending on the capacity of the driver. Refer to section 1.3 for availability of close mounting.
- When mounting the drivers closely, do not install the driver whose depth is larger than that of the left side driver since CNP1, CNP2, and CNP3 connectors cannot be disconnected.

Leave a large clearance between the top of the driver and the cabinet walls, and install a cooling fan to prevent the internal temperature of the cabinet from exceeding the environment.

When mounting the drivers closely, leave a clearance of 1 mm between the adjacent drivers in consideration of mounting tolerances. In this case, keep the ambient temperature within 0 °C to 45 °C or use the driver with 75% or less of the effective load ratio.

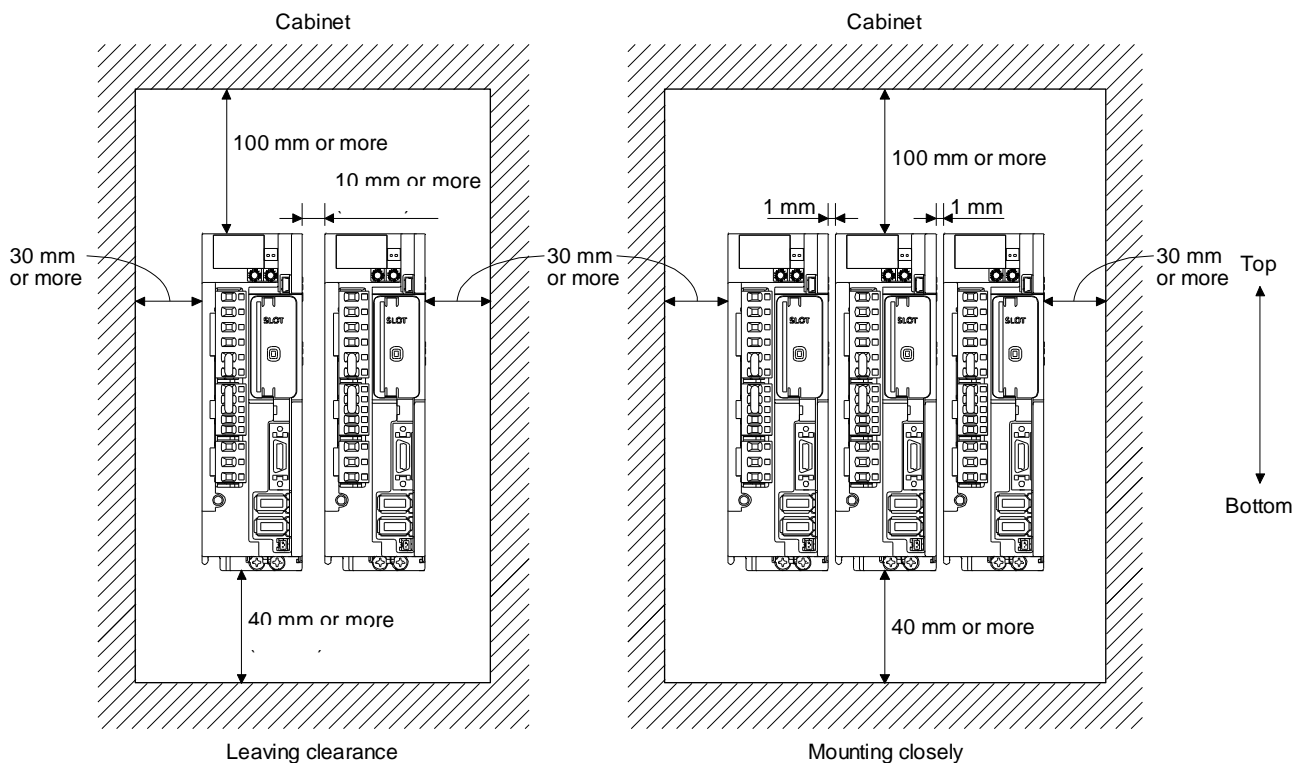

(2) Others

When using heat generating equipment such as the regenerative option, install them with full consideration of heat generation so that the driver is not affected.

Install the driver on a perpendicular wall in the correct vertical direction.

2. INSTALLATION

2.2 Keep out foreign materials

- (1) When drilling in the cabinet, prevent drill chips and wire fragments from entering the driver.
- (2) Prevent oil, water, metallic dust, etc. from entering the driver through openings in the cabinet or a cooling fan installed on the ceiling.
- (3) When installing the cabinet in a place where toxic gas, dirt and dust exist, conduct an air purge (force clean air into the cabinet from outside to make the internal pressure higher than the external pressure) to prevent such materials from entering the cabinet.

2.3 Encoder cable stress

- (1) The way of clamping the cable must be fully examined so that bending stress and cable's own weight stress are not applied to the cable connection.
- (2) For use in any application where the servo motor moves, fix the cables (encoder, power supply, and lock) with having some slack from the connector connection part of the servo motor to avoid putting stress on the connector connection part. Use the optional encoder cable within the bending life range. Use the power supply and lock wiring cables within the bending life of the cables.
- (3) Avoid any probability that the cable sheath might be cut by sharp chips, rubbed by a machine corner or stamped by workers or vehicles.
- (4) For installation on a machine where the servo motor moves, the bending radius should be made as large as possible. Refer to section 10.4 for the bending life.
- (5) The minimum bending radius : Min. 45mm.

2.4 Inspection items

 WARNING	<ul style="list-style-type: none">● Before starting maintenance and/or inspection, turn off the power and wait for 15 minutes or more until the charge lamp turns off. Then, confirm that the voltage between P+ and N- is safe with a voltage tester and others. Otherwise, an electric shock may occur. In addition, when confirming whether the charge lamp is off or not, always confirm it from the front of the driver.● To avoid an electric shock, only qualified personnel should attempt inspections.
--	--

 CAUTION	<ul style="list-style-type: none">● Do not perform insulation resistance test on the driver. Otherwise, it may cause a malfunction.● Do not disassemble and/or repair the equipment on customer side.
--	--

It is recommended that the following points periodically be checked.

- (1) Check for loose terminal block screws. Retighten any loose screws.
- (2) Check the cables and the like for scratches or cracks. Inspect them periodically according to operating conditions especially when the servo motor is movable.
- (3) Check that the connector is securely connected to the driver.
- (4) Check that the wires are not coming out from the connector.
- (5) Check for dust accumulation on the driver.
- (6) Check for unusual noise generated from the driver.

2. INSTALLATION

2.5 Parts having service lives

Service lives of the following parts are listed below. However, the service lives vary depending on operation and environment.

Part name	Life guideline
Smoothing capacitor	10 years
Relay	Number of power-on, forced stop by EM1 (Forced stop 1), and quick stop command from controller: 100,000 times Number of on and off for STO: 1,000,000 times
Cooling fan	10,000 hours to 30,000 hours (2 years to 3 years)
Absolute position battery	Refer to section 12.2.

(1) Smoothing capacitor

The characteristic of smoothing capacitor is deteriorated due to ripple currents, etc. The life of the capacitor greatly depends on ambient temperature and operating conditions. The capacitor will reach the end of its life in 10 years of continuous operation in normal air-conditioned environment (40 °C surrounding air temperature or less).

(2) Relays

Contact faults will occur due to contact wear arisen from switching currents. Relays reach the end of their lives when the power has been turned on, forced stop by EM1 (Forced stop 1) has occurred, and PC or PLC...etc forced stop has occurred 100,000 times in total, or when the STO has been turned on and off 1,000,000 times while the servo motor is stopped under servo-off state. However, the lives of relays may depend on the power supply capacity.

(3) Driver cooling fan

The cooling fan bearings reach the end of their life in 10,000 hours to 30,000 hours. Normally, therefore, the cooling fan must be replaced in a few years of continuous operation as a guideline. It must also be changed if unusual noise or vibration is found during inspection.

The life indicates under the yearly average ambient temperature of 40 °C, free from corrosive gas, flammable gas, oil mist, dust and dirt.

2. INSTALLATION

2.6 Restrictions when using this product at altitude exceeding 1000 m and up to 2000 m above sea level

(1) Effective load ratio and regenerative load ratio

As heat dissipation effects decrease in proportion to the decrease in air density, use the product Within the effective load ratio and regenerative load ratio shown in the following figure.

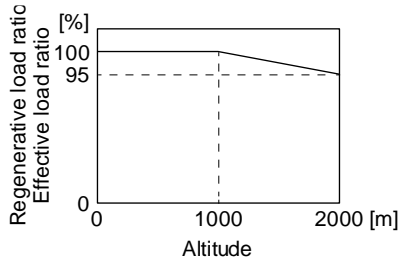

When closely mounting the drivers, operate them at the ambient temperature of 0 °C to 45 °C or at 75% or smaller effective load ratio. (Refer to section 2.1.)

(2) Input voltage

Generally, a withstand voltage decreases as increasing altitude; however, there is no restriction on the withstand voltage. Use in the same manner as in 1000 m or less. (Refer to section 1.3.)

(3) Parts having service life

(a) Smoothing capacitor

The capacitor will reach the end of its life in 10 years of continuous operation in air-conditioned environment (ambient temperature of 30 °C or less).

(b) Relay

There is no restriction. Use in the same manner as in 1000 m or less. (Refer to section 2.5.)

(c) Driver cooling fan

There is no restriction. Use in the same manner as in 1000 m or less. (Refer to section 2.5.)

3. SIGNALS AND WIRING

3. SIGNALS AND WIRING	2
3.1 Input power supply circuit	3
3.2 I/O signal connection example	6
3.2.1 For sink I/O interface	6
3.2.2 For source I/O interface	7
3.3 Explanation of power supply system	8
3.3.1 Signal explanations	8
3.3.2 Power-on sequence	9
3.3.3 Wiring CNP1, CNP2, and CNP3	10
3.4 Connectors and pin assignment	12
3.5 Signal (device) explanations	14
3.5.1 Input device	14
3.5.2 Output device	16
3.5.3 Output signal	18
3.5.4 Power supply	18
3.6 Forced stop deceleration function	19
3.6.1 Forced stop deceleration function	19
3.6.2 Base circuit shut-off delay time function	21
3.6.3 Vertical axis freefall prevention function	22
3.6.4 Residual risks of the forced stop function (EM2)	22
3.7 Alarm occurrence timing chart	23
3.7.1 When you use the forced stop deceleration function	23
3.7.2 When you do not use the forced stop deceleration function	24
3.8 Interfaces	25
3.8.1 Internal connection diagram	25
3.8.2 Detailed explanation of interfaces	26
3.8.3 Source I/O interfaces	28
3.9 Servo motor with a lock	29
3.9.1 Safety precautions	29
3.9.2 Timing chart	30
3.9.3 Wiring diagrams (LE-□-□ series servo motor)	36
3.10 Grounding	37

3. SIGNALS AND WIRING

3. SIGNALS AND WIRING

! WARNING

- Any person who is involved in wiring should be fully competent to do the work.
- Before wiring, turn off the power and wait for 15 minutes or more until the charge lamp turns off. Then, confirm that the voltage between P+ and N- is safe with a voltage tester and others. Otherwise, an electric shock may occur. In addition, when confirming whether the charge lamp is off or not, always confirm it from the front of the driver.
- Ground the driver and servo motor securely.
- Do not attempt to wire the driver and servo motor until they have been installed. Otherwise, it may cause an electric shock.
- The cables should not be damaged, stressed, loaded, or pinched. Otherwise, it may cause an electric shock.
- To avoid an electric shock, insulate the connections of the power supply terminals.

- Wire the equipment correctly and securely. Otherwise, the servo motor may operate unexpectedly, resulting in injury.
- Connect cables to the correct terminals. Otherwise, a burst, damage, etc. may occur.
- Ensure that polarity (+/-) is correct. Otherwise, a burst, damage, etc. may occur.
- The surge absorbing diode installed to the DC relay for control output should be fitted in the specified direction. Otherwise, the emergency stop and other protective circuits may not operate.

Driver
DOCOM (DOCOMD)
Control output signal
24 V DC
RA
For sink output interface

Driver
DOCOM (DOCOMD)
Control output signal
24 V DC
RA
For source output interface

! CAUTION

- Use a noise filter, etc. to minimize the influence of electromagnetic interference. Electromagnetic interference may be given to the electronic equipment used near the driver.
- Do not install a power capacitor, surge killer or radio noise filter (optional FR-BIF (-H)) with the power line of the servo motor.
- When using the regenerative resistor, switch power off with the alarm signal. Otherwise, a transistor fault or the like may overheat the regenerative resistor, causing a fire.
- Do not modify the equipment.
- Connect the driver power output (U/V/W) to the servo motor power input (U/V/W) directly. Do not let a magnetic contactor, etc. intervene. Otherwise, it may cause a malfunction.

Driver
U
V
W
Servo motor
U
V
W
M

Driver
U
V
W
Servo motor
U
V
W
M

3. SIGNALS AND WIRING

CAUTION

- Connecting a servo motor of the wrong axis to U, V, W, or CN2 of the driver may cause a malfunction.
- Before wiring, switch operation, etc., eliminate static electricity. Otherwise, it may cause a malfunction.

3.1 Input power supply circuit

CAUTION

- Always connect a magnetic contactor between the power supply and the main circuit power supply (L1/L2/L3) of the driver, in order to configure a circuit that shuts down the power supply on the side of the driver's power supply. If a magnetic contactor is not connected, continuous flow of a large current may cause a fire when the driver malfunctions.
- Use ALM (Malfunction) to switch main circuit power supply off. Not doing so may cause a fire when a regenerative transistor malfunctions or the like may overheat the regenerative resistor.
- Check the driver model, and then input proper voltage to the driver power supply. If input voltage exceeds the upper limit of the specification, the driver will break down.
- The driver has a built-in surge absorber (varistor) to reduce exogenous noise and to suppress lightning surge. Exogenous noise or lightning surge deteriorates the varistor characteristics, and the varistor may be damaged. To prevent a fire, use a molded-case circuit breaker or fuse for input power supply.
- Connecting a servo motor of the wrong axis to U, V, W, or CN2 of the driver may cause a malfunction.
- The N- terminal is not a neutral point of the power supply. Incorrect wiring will cause a burst, damage, etc.

POINT

- Even if alarm has occurred, do not switch off the control circuit power supply. When the control circuit power supply has been switched off, network card does not operate, and transmission of network communication is interrupted. Therefore, the next axis driver displays "AA" at the indicator and turns into base circuit shut-off. The servo motor stops with starting dynamic brake.
- EM2 has the same function as EM1 in the torque mode.

Configure the wiring so that the main circuit power supply is shut off and the servo-on command turns off after deceleration to a stop due to an alarm occurring, an enabled servo forced stop, or a quick stop command from upper side. A molded-case circuit breaker (MCCB) must be used with the input cables of the main circuit power supply.

3. SIGNALS AND WIRING

(1) Using 3-phase 200 V AC to 240 V AC power supply for LECSND2-T□

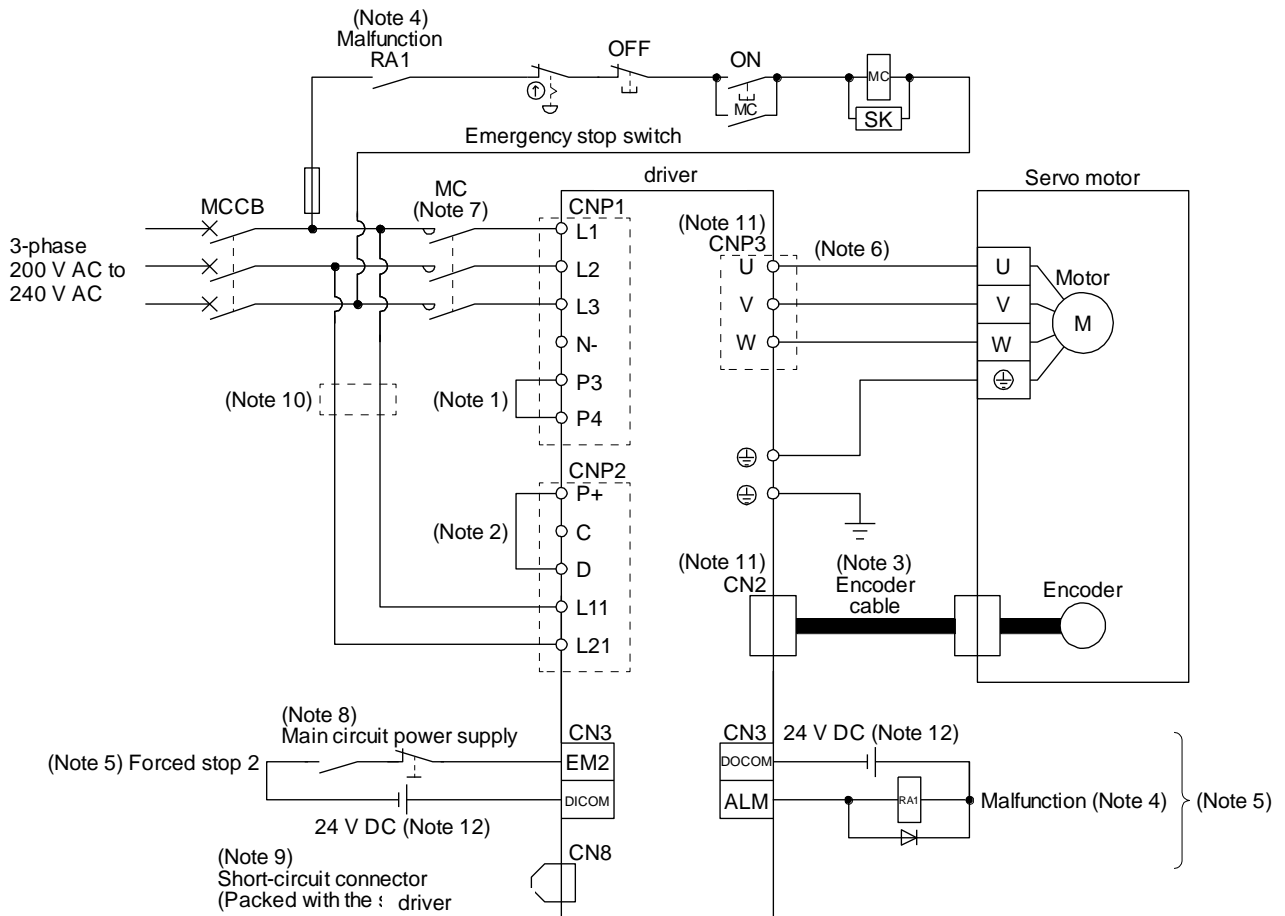

- Note 1. Between P3 and P4 is connected by default.
- Note 2. Always connect between P+ and D terminals. (factory-wired) When using the regenerative option, refer to section 11.2.
- Note 3. If disabling ALM (Malfunction) output with the parameter, configure up the power supply circuit which switches off the magnetic contactor after detection of alarm occurrence on the upper side side.
- Note 4. This diagram shows sink I/O interface. For source I/O interface, refer to section 3.8.3.
- Note 5. Use a magnetic contactor with an operation delay time (interval between current being applied to the coil until closure of contacts) of 80 ms or less. Depending on the main circuit voltage and operation pattern, bus voltage decreases, and that may cause the forced stop deceleration to shift to the dynamic brake deceleration. When dynamic brake deceleration is not required, slow the time to turn off the magnetic contactor.
- Note 6. Configure a circuit to turn off EM2 when the main circuit power is turned off to prevent an unexpected restart of the driver
- Note 7. When not using the STO function, attach the short-circuit connector came with a driver.
- Note 8. When wires used for L11 and L21 are thinner than wires used for L1, L2, and L3, use a molded-case circuit breaker. (Refer to section 11.10.)
- Note 9. Connecting a servo motor of the wrong axis to U, V, W, or CN2 of the driver may cause a malfunction.
- Note 10. The illustration of the 24 V DC power supply is divided between input signal and output signal for convenience. However, they can be configured by one.

3. SIGNALS AND WIRING

(2) Using 1-phase 200 V AC to 240 V AC power supply for LECSND2-T□

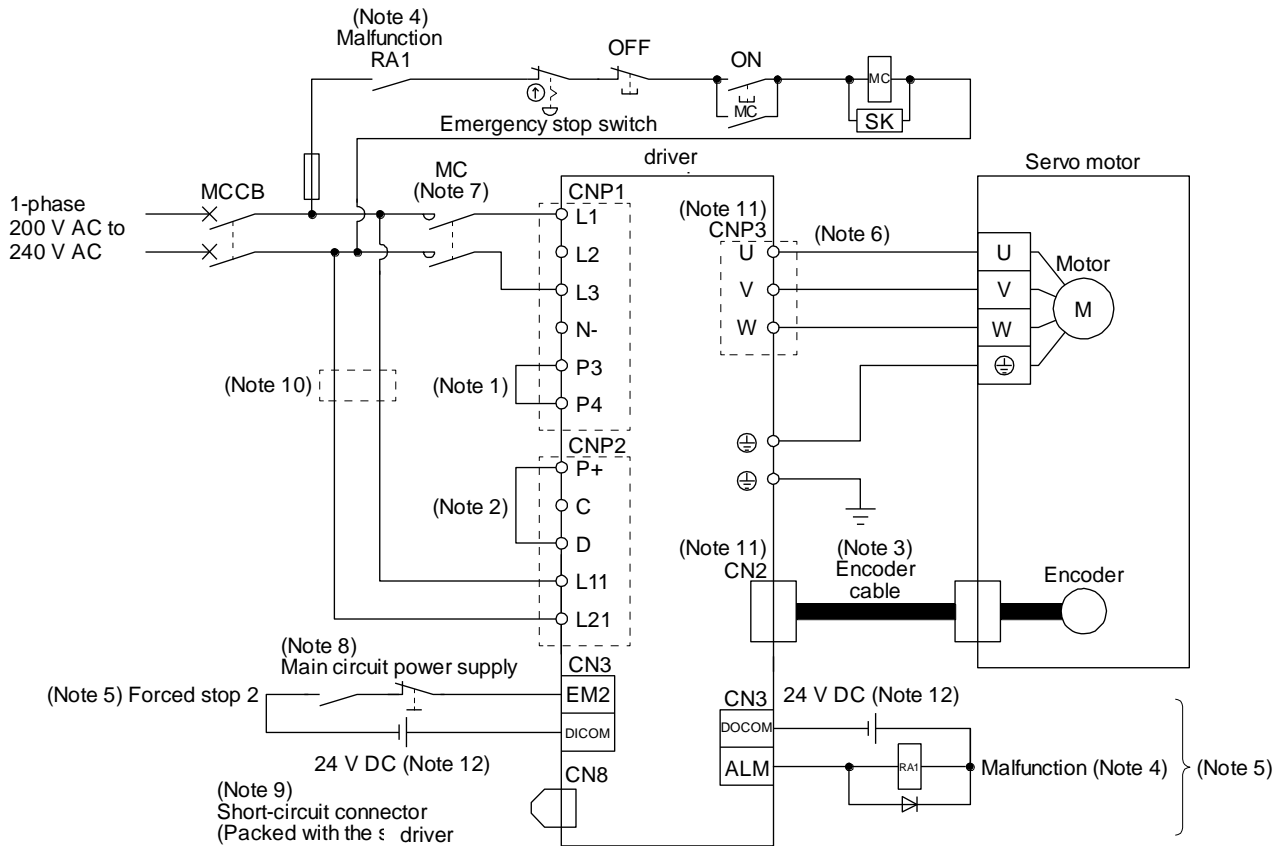

- Note 1. Between P3 and P4 is connected by default.
- Note 2. Always connect between P+ and D terminals. (factory-wired) When using the regenerative option, refer to section 11.2.
- Note 3. If disabling ALM (Malfunction) output with the parameter, configure up the power supply circuit which switches off the magnetic contactor after detection of alarm occurrence on the upper side side.
- Note 4. This diagram shows sink I/O interface. For source I/O interface, refer to section 3.8.3.
- Note 5. Use a magnetic contactor with an operation delay time (interval between current being applied to the coil until closure of contacts) of 80 ms or less. Depending on the main circuit voltage and operation pattern, bus voltage decreases, and that may cause the forced stop deceleration to shift to the dynamic brake deceleration. When dynamic brake deceleration is not required, slow the time to turn off the magnetic contactor.
- Note 6. Configure a circuit to turn off EM2 when the main circuit power is turned off to prevent an unexpected restart of the driver
- Note 7. When not using the STO function, attach the short-circuit connector came with a driver.
- Note 8. When wires used for L11 and L21 are thinner than wires used for L1, and L3, use a molded-case circuit breaker. (Refer to section 11.10.)
- Note 9. Connecting a servo motor of the wrong axis to U, V, W, or CN2 of the driver may cause a malfunction.
- Note 10. The illustration of the 24 V DC power supply is divided between input signal and output signal for convenience. However, they can be configured by one.

3. SIGNALS AND WIRING

3.2 I/O signal connection example

POINT
●EM2 has the same function as EM1 in the torque mode.

3.2.1 For sink I/O interface

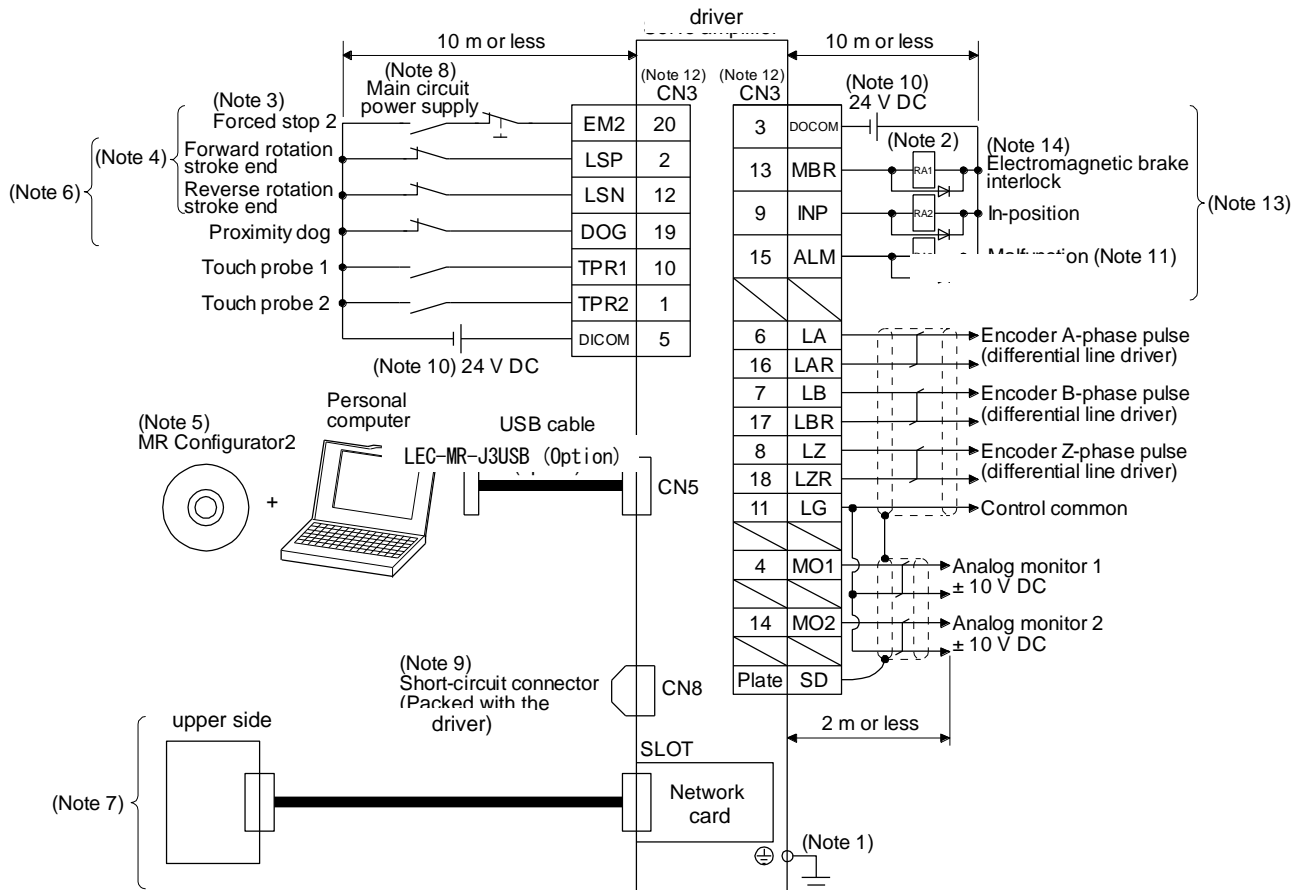

- Note 1. To prevent an electric shock, always connect the protective earth (PE) terminal (marked ⊕) of the driver to the protective earth (PE) of the cabinet.
- Note 2. Connect the diode in the correct direction. If it is connected reversely, the driver will malfunction and will not output signals, disabling EM2 (Forced stop 2) and other protective circuits.
- Note 3. If the upper side does not have forced stop function, always install the forced stop 2 switch (normally closed contact).
- Note 4. When starting operation, always turn on EM2 (Forced stop 2), LSP (Forward rotation stroke end) and LSN (Reverse rotation stroke end). (Normally closed contact)
- Note 6. You can change devices of these pins with [Pr. PD03], [Pr. PD05], and [Pr. PD06].
- Note 7. For the network connections, refer to chapter 18,19,20.
- Note 8. Configure a circuit to turn off EM2 when the main circuit power is turned off to prevent an unexpected restart of the driver.
- Note 9. When not using the STO function, attach the short-circuit connector came with a driver.
- Note 10. Supply 24 V DC ± 10% for interfaces from outside. Set the total current capacity to 300 mA. 300 mA is the value applicable when all I/O signals are used. The current capacity can be decreased by reducing the number of I/O points. Refer to section 3.8.2 (1) that gives the current value necessary for the interface. The illustration of the 24 V DC power supply is divided between input signal and output signal for convenience. However, they can be configured by one.
- Note 11. ALM (Malfunction) turns on in normal alarm-free condition. (Normally closed contact)
- Note 12. The pins with the same signal name are connected in the driver.
- Note 13. You can change devices of these pins with [Pr. PD07], [Pr. PD08], and [Pr. PD09].

3. SIGNALS AND WIRING

3.2.2 For source I/O interface

POINT
 ● For notes, refer to section 3.2.1.

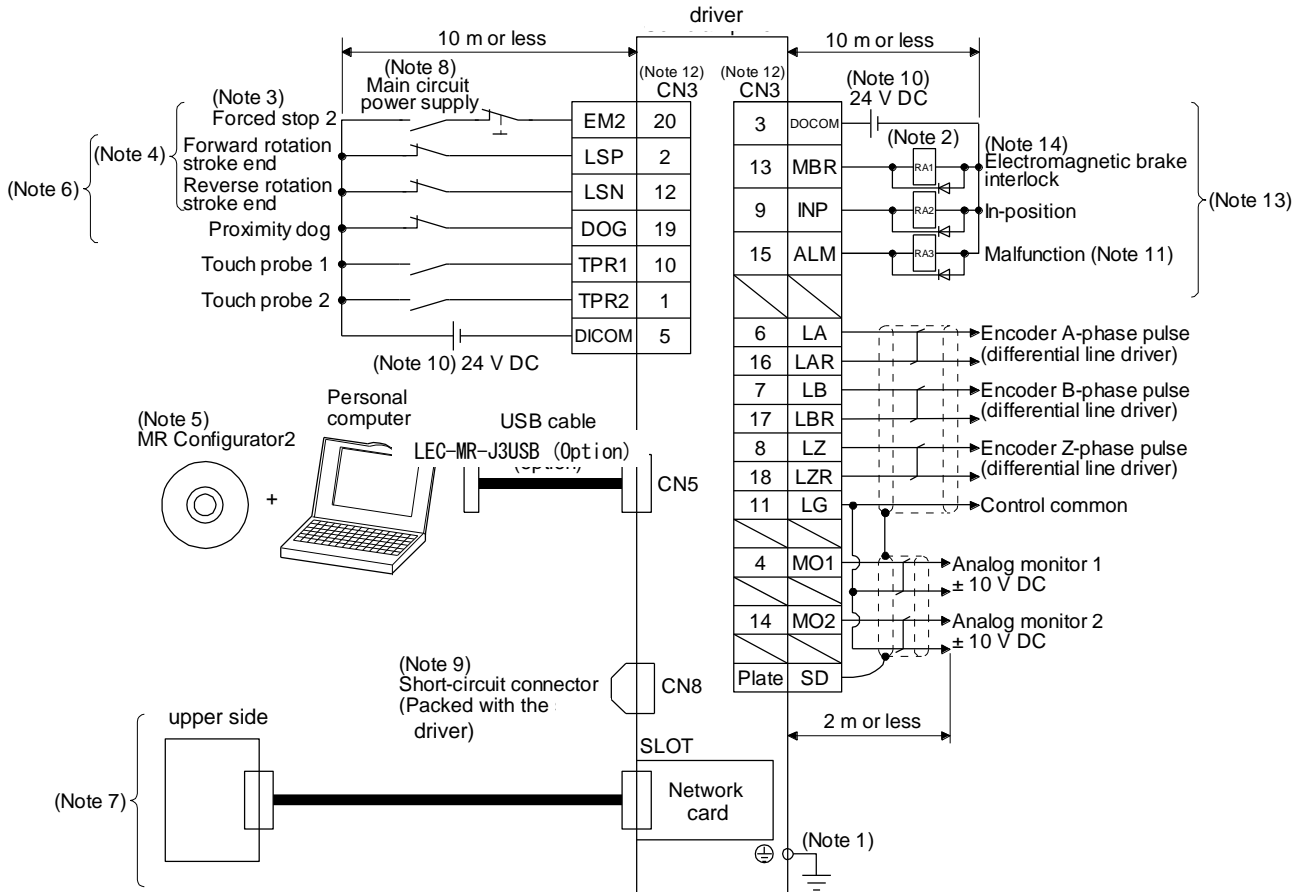

3. SIGNALS AND WIRING

3.3 Explanation of power supply system

3.3.1 Signal explanations

POINT
● For the layout of connector and terminal block, refer to chapter 9.

Symbol	Connection target (application)	Description								
L1/L2/L3	Main circuit power supply	<p>Supply the following power to L1, L2, and L3. For 1-phase 200 V AC to 240 V AC, connect the power supply to L1 and L3. Leave L2 open.</p> <table border="1" style="width: 100%;"> <tr> <td style="text-align: center;">Driver</td> <td style="text-align: center;">LECSND2-T5 ~ LECSND2-T9</td> </tr> <tr> <td>Power</td> <td></td> </tr> <tr> <td>3-phase 200 V AC to 240 V AC, 50 Hz/60 Hz</td> <td style="text-align: center;">L1/L2/L3</td> </tr> <tr> <td>1-phase 200 V AC to 240 V AC, 50 Hz/60 Hz</td> <td style="text-align: center;">L1/L3</td> </tr> </table>	Driver	LECSND2-T5 ~ LECSND2-T9	Power		3-phase 200 V AC to 240 V AC, 50 Hz/60 Hz	L1/L2/L3	1-phase 200 V AC to 240 V AC, 50 Hz/60 Hz	L1/L3
Driver	LECSND2-T5 ~ LECSND2-T9									
Power										
3-phase 200 V AC to 240 V AC, 50 Hz/60 Hz	L1/L2/L3									
1-phase 200 V AC to 240 V AC, 50 Hz/60 Hz	L1/L3									
P3/P4	-	connect P3 and P4. (factory-wired)								
P+/C/D	Regenerative option	<p>When using a driver built-in regenerative resistor, connect P+ and D. (factory-wired)</p> <p>When using a regenerative option, disconnect P+ and D, and connect the regenerative option to P+ and C.</p> <p>Refer to section 11.2 for details.</p>								

Symbol	Connection target (application)	Description						
L11/L21	Control circuit power supply	<p>Supply the following power to L11 and L21.</p> <table border="1" style="width: 100%;"> <tr> <td style="text-align: center;">Driver</td> <td style="text-align: center;">LECSND2-T5 ~ LECSND2-T9</td> </tr> <tr> <td>Power</td> <td></td> </tr> <tr> <td>1-phase 200 V AC to 240 V AC, 50 Hz/60 Hz</td> <td style="text-align: center;">L11/L21</td> </tr> </table>	Driver	LECSND2-T5 ~ LECSND2-T9	Power		1-phase 200 V AC to 240 V AC, 50 Hz/60 Hz	L11/L21
Driver	LECSND2-T5 ~ LECSND2-T9							
Power								
1-phase 200 V AC to 240 V AC, 50 Hz/60 Hz	L11/L21							
U/V/W	Servo motor power	Connect the driver power output (U/V/W) to the servo motor power input (U/V/W) directly. Do not let a magnetic contactor, etc. intervene. Otherwise, it may cause a malfunction.						
N-	-	Do not connect it.						
⊕	Protective earth (PE)	Connect it to the grounding terminal of the servo motor and to the protective earth (PE) of the cabinet for grounding.						

3. SIGNALS AND WIRING

3.3.2 Power-on sequence

POINT
● The output signal, etc. may be unstable at power-on.

(1) Power-on procedure

- 1) Always wire the power supply as shown in above section 3.1 using the magnetic contactor with the main circuit power supply (L1/L2/L3). Configure up an external sequence to switch off the magnetic contactor as soon as an alarm occurs.
- 2) Switch on the control circuit power supply (L11/L21) simultaneously with the main circuit power supply or before switching on the main circuit power supply. If the control circuit power supply is turned on with the main circuit power supply off, and then the servo-on command is transmitted, [AL. E9 Main circuit off warning] will occur. Turning on the main circuit power supply stops the warning and starts the normal operation.
- 3) The driver receives the servo-on command in 3 s to 4 s + network initial communication time after the main circuit power supply is switched on.
(Refer to (2) in this section.)

(2) Timing chart

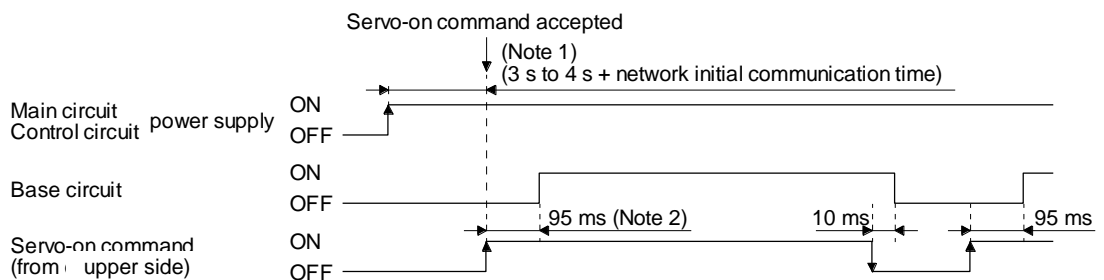

3. SIGNALS AND WIRING

3.3.3 Wiring CNP1, CNP2, and CNP3

POINT
● For the wire sizes used for wiring, refer to section 11.9.
● When wiring, remove the power connectors from the driver.
● Insert only one wire or ferrule to each wire insertion hole.

Use the driver power supply connector for wiring CNP1, CNP2, and CNP3.

- (1) Connector
 (a) LECSND□-T□

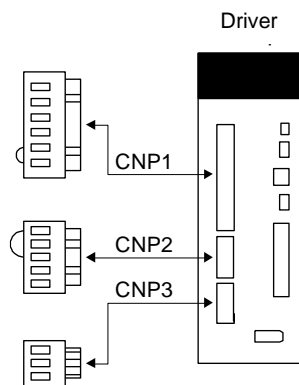

Table 3.1 Connector and applicable wire

Connector	Receptacle assembly	Applicable wire		Stripped length [mm]	Manufacturer
		Size	Insulator OD		
CNP1	K05A01490252	AWG 18 to 14	39 mm or shorter	9	MITSUBISHI ELECTRIC SYSTEM & SERVICE CO., LTD (Note)
CNP2	K05A01490253				
CNP3	K05A01490254				

Note. Please purchase from distributor or distributor of Mitsubishi Electric Corporation.

(Note)

If you order CNP1(K05A01490252), an open tool will be included with the connector.

3. SIGNALS AND WIRING

(2) Cable connection procedure

(a) Fabrication on cable insulator

Refer to table 3.1 to 3.4 for stripped length of cable insulator. The appropriate stripped length of cables depends on their type, etc. Set the length considering their status.

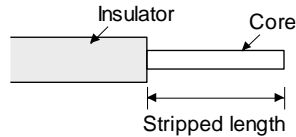

Twist strands lightly and straighten them as follows.

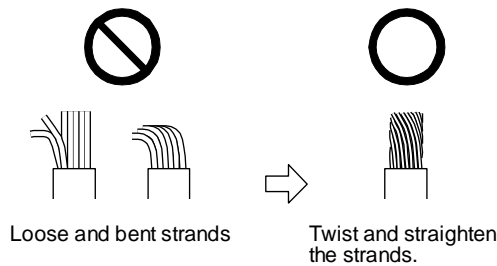

You can also use a ferrule to connect with the connectors. The following shows references to select ferrules according to wire sizes.

Driver	Wire size	Ferrule model (Phoenix Contact)		Crimping tool (Phoenix Contact)
		For one	For two	
LECSND□-T5 ~ LECSND□-T8, LECSND2-T9	AWG 16	AI1.5-10BK	AI-TWIN2x1.5-10BK	CRIMPFOX-ZA3
	AWG 14	AI2.5-10BU		

(b) Inserting wire

Insert only one wire or ferrule to each wire insertion hole.

Insert the open tool as follows and push it down to open the spring. While the open tool is pushed down, insert the stripped wire into the wire insertion hole. Check the wire insertion depth, and make sure that the cable insulator will not be caught by the spring and that the conductive part of the stripped wire will not be exposed.

Release the open tool to fix the wire. Pull the wire lightly to confirm that the wire is surely connected. In addition, make sure that no conductor wire sticks out of the connector.

The following shows a connection example of the CNP3 connector.

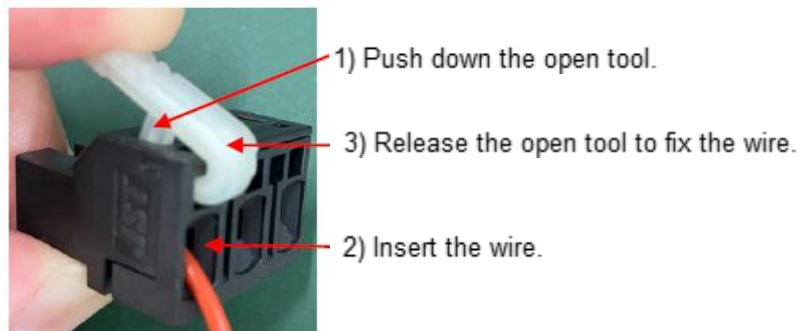

3. SIGNALS AND WIRING

3.4 Connectors and pin assignment

POINT
<ul style="list-style-type: none">● The pin assignment of the connectors is as viewed from the cable connector wiring section.● For the STO I/O signal connector (CN8), refer to chapter 13.● For the CN1 connector, securely connect the external conductive portion of the shielded cable to the ground plate and fix it to the connector shell.

The diagram illustrates the assembly of a shielded cable connector. On the left, a perspective view shows a cable with a braided shield being secured to a metal ground plate. Two screws are used: one to clamp the shield to the ground plate and another to secure the cable to the connector shell. On the right, a top-down view shows the cable and shield assembly fully mounted on the connector shell.

3. SIGNALS AND WIRING

The driver front view shown is that of the LECSND□-T7 or less. Refer to chapter 9 DIMENSIONS for the appearances and connector layouts of the other drivers.

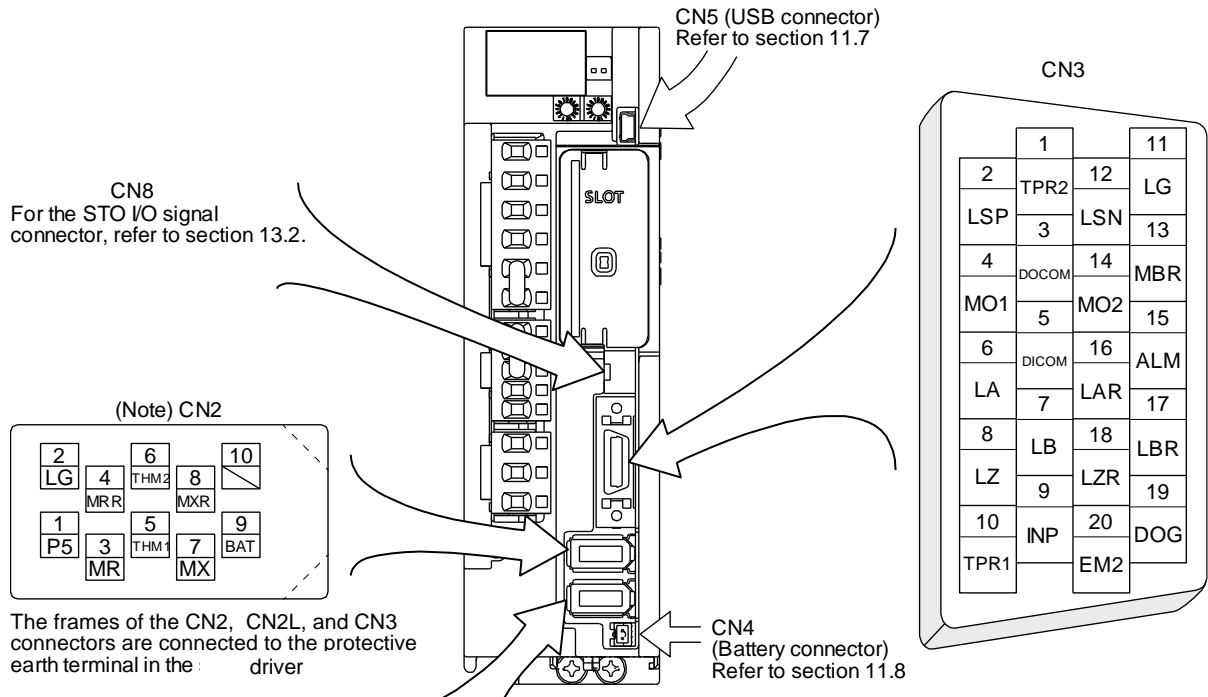

Note. CN2L cannot be used. Connect the encoder cable to CN2.

3. SIGNALS AND WIRING

3.5 Signal (device) explanations

For the I/O interfaces (symbols in I/O division column in the table), refer to section 3.8.2.

The pin numbers in the connector pin No. column are those in the initial status.

3.5.1 Input device

(1) Input device pin

The following shows the input device pins and parameters for setting devices.

Connector pin No.	Parameter	Initial device	I/O division
CN3-2	[Pr. PD03]	LSP	DI-1
CN3-12	[Pr. PD04]	LSN	
CN3-19	[Pr. PD05]	DOG	
CN3-10	[Pr. PD38]	TPR1	
CN3-20	[Pr. PA04]	EM2	

The on/off statuses of the pins can be read with "Digital inputs" of the object.

For details, refer to chapter 18,19,20.

(2) Input device explanations

Device	Symbol	Connector pin No.	Function and application	I/O division																						
Forced stop 2	EM2	CN3-20	<p>Turn off EM2 (open between commons) to decelerate the servo motor to a stop with commands.</p> <p>Turn EM2 on (short between commons) in the forced stop state to reset that state.</p> <p>Set [Pr. PA04] to "2 1 _ _" to disable EM2.</p> <p>The following shows the setting of [Pr. PA04].</p> <table border="1" style="width: 100%; border-collapse: collapse;"> <thead> <tr> <th rowspan="2">[Pr. PA04] setting</th> <th rowspan="2">EM2/EM1</th> <th colspan="2">Deceleration method</th> </tr> <tr> <th>EM2 or EM1 is off</th> <th>Alarm occurred</th> </tr> </thead> <tbody> <tr> <td>0 0 _ _</td> <td>EM1</td> <td>MBR (Lock interlock) turns off without the forced stop deceleration.</td> <td>MBR (Lock interlock) turns off without the forced stop deceleration.</td> </tr> <tr> <td>2 0 _ _</td> <td>EM2</td> <td>MBR (Lock interlock) turns off after the forced stop deceleration.</td> <td>MBR (Lock interlock) turns off after the forced stop deceleration.</td> </tr> <tr> <td>0 1 _ _</td> <td>Not using EM2 and EM1</td> <td style="text-align: center;">\</td> <td>MBR (Lock interlock) turns off without the forced stop deceleration.</td> </tr> <tr> <td>2 1 _ _</td> <td>Not using EM2 and EM1</td> <td style="text-align: center;">/</td> <td>MBR (Lock interlock) turns off after the forced stop deceleration.</td> </tr> </tbody> </table> <p>EM2 and EM1 are mutually exclusive. EM2 has the same function as EM1 in the torque mode.</p>	[Pr. PA04] setting	EM2/EM1	Deceleration method		EM2 or EM1 is off	Alarm occurred	0 0 _ _	EM1	MBR (Lock interlock) turns off without the forced stop deceleration.	MBR (Lock interlock) turns off without the forced stop deceleration.	2 0 _ _	EM2	MBR (Lock interlock) turns off after the forced stop deceleration.	MBR (Lock interlock) turns off after the forced stop deceleration.	0 1 _ _	Not using EM2 and EM1	\	MBR (Lock interlock) turns off without the forced stop deceleration.	2 1 _ _	Not using EM2 and EM1	/	MBR (Lock interlock) turns off after the forced stop deceleration.	DI-1
[Pr. PA04] setting	EM2/EM1	Deceleration method																								
		EM2 or EM1 is off	Alarm occurred																							
0 0 _ _	EM1	MBR (Lock interlock) turns off without the forced stop deceleration.	MBR (Lock interlock) turns off without the forced stop deceleration.																							
2 0 _ _	EM2	MBR (Lock interlock) turns off after the forced stop deceleration.	MBR (Lock interlock) turns off after the forced stop deceleration.																							
0 1 _ _	Not using EM2 and EM1	\	MBR (Lock interlock) turns off without the forced stop deceleration.																							
2 1 _ _	Not using EM2 and EM1	/	MBR (Lock interlock) turns off after the forced stop deceleration.																							
Forced stop 1	EM1	(CN3-20)	<p>When using EM1, set [Pr. PA04] to "0 0 _ _" to enable EM1.</p> <p>When EM1 is turned off (open between commons), the base circuit shuts off, and the dynamic brake operates to decelerate the servo motor to a stop.</p> <p>The forced stop will be reset when EM1 is turned on (short between commons).</p> <p>Set [Pr. PA04] to "0 1 _ _" to disable EM1.</p>	DI-1																						

3. SIGNALS AND WIRING

Device	Symbol	Connector pin No.	Function and application	I/O division																																					
Touch probe 1	TPR1	CN3-10	The touch probe function is available to latch the current position by sensor input. Turn it on to latch the current position. For the touch probe function, refer to chapter 18,19,20.	DI-1																																					
Touch probe 2	TPR2	CN3-1		DI-1																																					
Operation start-up	ST	(CN3-10)	Use this device for the positioning function by the operation start-up signal. For details, refer to chapter 18,19,20.	DI-1																																					
Forward rotation stroke end	LSP	CN3-2	To start the operation, turn on LSP and LSN. Turn it off to bring the servo motor to a slow stop and make it servo-locked.	DI-1																																					
Reverse rotation stroke end	LSN	CN3-12																																							
			<table border="1"> <thead> <tr> <th colspan="2">(Note) Input device</th> <th colspan="2">Operation</th> </tr> <tr> <th>LSP</th> <th>LSN</th> <th>CCW direction Positive direction</th> <th>CW direction Negative direction</th> </tr> </thead> <tbody> <tr> <td>1</td> <td>1</td> <td style="text-align: center;">○</td> <td style="text-align: center;">○</td> </tr> <tr> <td>0</td> <td>1</td> <td style="text-align: center;">/</td> <td style="text-align: center;">○</td> </tr> <tr> <td>1</td> <td>0</td> <td style="text-align: center;">○</td> <td style="text-align: center;">/</td> </tr> <tr> <td>0</td> <td>0</td> <td style="text-align: center;">/</td> <td style="text-align: center;">/</td> </tr> </tbody> </table> <p>Note. 0: Off 1: On</p> <p>Setting [Pr. PD01] as follows turn the signals on automatically (always connected) in the driver.</p> <table border="1"> <thead> <tr> <th rowspan="2">[Pr. PD01]</th> <th colspan="2">Status</th> </tr> <tr> <th>LSP</th> <th>LSN</th> </tr> </thead> <tbody> <tr> <td>_ 4 _ _</td> <td>Automatic on</td> <td style="text-align: center;">/</td> </tr> <tr> <td>_ 8 _ _</td> <td style="text-align: center;">/</td> <td>Automatic on</td> </tr> <tr> <td>_ C _ _</td> <td>Automatic on</td> <td>Automatic on</td> </tr> </tbody> </table> <p>When LSP or LSN is turned off, [AL. 99 Stroke limit warning] occurs. In the torque mode, this device cannot be used during normal operation.</p>	(Note) Input device		Operation		LSP	LSN	CCW direction Positive direction	CW direction Negative direction	1	1	○	○	0	1	/	○	1	0	○	/	0	0	/	/	[Pr. PD01]	Status		LSP	LSN	_ 4 _ _	Automatic on	/	_ 8 _ _	/	Automatic on	_ C _ _	Automatic on	Automatic on
(Note) Input device		Operation																																							
LSP	LSN	CCW direction Positive direction	CW direction Negative direction																																						
1	1	○	○																																						
0	1	/	○																																						
1	0	○	/																																						
0	0	/	/																																						
[Pr. PD01]	Status																																								
	LSP	LSN																																							
_ 4 _ _	Automatic on	/																																							
_ 8 _ _	/	Automatic on																																							
_ C _ _	Automatic on	Automatic on																																							
Proximity dog	DOG	CN3-19	Proximity dog at home position return will be detected. The polarity for dog detection can be changed with [Pr. PT29].	DI-1																																					
			<table border="1"> <thead> <tr> <th rowspan="3">[Pr. PT29]</th> <th colspan="2">Polarity for proximity dog detection</th> </tr> <tr> <th colspan="2">Profile mode</th> </tr> <tr> <th>Cyclic synchronous mode Point table method</th> <th>Indexer method</th> </tr> </thead> <tbody> <tr> <td>_ _ _ 0</td> <td>Dog detection with off</td> <td>Dog detection with on</td> </tr> <tr> <td>_ _ _ 1</td> <td>Dog detection with on</td> <td>Dog detection with off</td> </tr> </tbody> </table>	[Pr. PT29]	Polarity for proximity dog detection		Profile mode		Cyclic synchronous mode Point table method	Indexer method	_ _ _ 0	Dog detection with off	Dog detection with on	_ _ _ 1	Dog detection with on	Dog detection with off																									
[Pr. PT29]	Polarity for proximity dog detection																																								
	Profile mode																																								
	Cyclic synchronous mode Point table method	Indexer method																																							
_ _ _ 0	Dog detection with off	Dog detection with on																																							
_ _ _ 1	Dog detection with on	Dog detection with off																																							

3. SIGNALS AND WIRING

Device	Symbol	Connector pin No.	Function and application	I/O division
Proportional control	PC		Turn PC on to switch the speed amplifier from the proportional integral type to the proportional type. If the servo motor at a stop is rotated even one pulse due to any external factor, it generates torque to compensate for a position shift. When the servo motor shaft is to be locked mechanically after positioning completion (stop), switching on the PC (Proportion control) upon positioning completion will suppress the unnecessary torque generated to compensate for a position shift. When the shaft is to be locked for a long time, switch on the PC (Proportion control) at the same time to make the torque less than the rated one. Do not use PC (Proportional control) in the torque mode. When PC (Proportional control) is used in the torque mode, operation may be performed at a speed exceeding the speed limit value.	DI-1
Gain switching	CDP		Turn on CDP to use the values of [Pr. PB29] to [Pr. PB36] and [Pr. PB56] to [Pr. PB60] as the load to motor inertia ratio and gain values.	DI-1
Fully closed loop selection	CLD		This is used when the semi closed loop control/fully closed loop control switching is enabled with [Pr. PE01]. Turn off CLD to select the semi closed loop control, and turn on CLD to select the fully closed loop control.	DI-1
General-purpose input A	DIA		When using input signals of the driver with a upper side, use this device.	DI-1
General-purpose input B	DIB			
General-purpose input C	DIC			

3.5.2 Output device

(1) Output device pin

The following shows the output device pins and parameters for assigning devices.

Connector pin No.	Parameter	Initial device	I/O division
CN3-13	[Pr. PD07]	MBR	DO-1
CN3-9	[Pr. PD08]	INP	
CN3-15	[Pr. PD09]	ALM	

(2) Output device explanations

Device	Symbol	Function and application
Lock interlock	MBR	When using the device, set operation delay time of the lock in [Pr. PC02]. When a servo-off status or alarm occurs, MBR will turn off.
Malfunction	ALM	When the protective circuit is activated to shut off the base circuit, ALM will turn off. When an alarm does not occur, ALM will turn on after 2.5 s to 3.5 s after power-on.
In-position	INP	When the number of droop pulses is in the in-position range, INP will turn on. The in-position range can be changed using [Pr. PA10]. When the in-position range is increased, INP may be on during low-speed rotation. The device cannot be used in the velocity mode and torque mode.
Dynamic brake interlock	DB	When using the signal, enable it by the setting of [Pr. PD07] to [Pr. PD09]. DB turns off when the dynamic brake needs to operate. When using the external dynamic brake on the driver of 11 kW or more, this device is required. (Refer to section 11.17.) For the driver of 7 kW or less, it is not necessary to use this device. The external dynamic brake cannot be used with 11 kW or more driver for compliance with SEMI-F47 standard. Do not assign DB (Dynamic brake interlock) in [Pr. PD07] to [Pr. PD09]. Failure to do so will cause the driver to become servo-off when an instantaneous power failure occurs.
Ready	RD	Enabling servo-on to make the driver ready to operate will turn on RD.
Speed reached	SA	SA will turn off during servo-off. When the servo motor speed reaches the following range, SA will turn on. Set speed $\pm ((\text{Set speed} \times 0.05) + 20)$ r/min When the preset speed is 20 r/min or less, SA always turns on. The device cannot be used in the position mode and torque mode.

3. SIGNALS AND WIRING

Device	Symbol	Function and application
Limiting speed	VLC	When the speed reaches the speed limit value in the torque mode, VLC will turn on. When the servo is off, TLC will be turned off. The device cannot be used in the position mode and velocity mode.
Zero speed detection	ZSP	<p>ZSP turns on when the servo motor speed is zero speed (50 r/min) or less. Zero speed can be changed with [Pr. PC07].</p> <p>Forward rotation direction: OFF level 70 r/min, ON level 50 r/min</p> <p>Servo motor speed: 0 r/min</p> <p>Reverse rotation direction: ON level -50 r/min, OFF level -70 r/min</p> <p>ZSP (Zero speed detection): ON, OFF</p> <p>20 r/min (Hysteresis width) [Pr. PC07]</p> <p>20 r/min (Hysteresis width) [Pr. PC07]</p> <p>ZSP will turn on when the servo motor is decelerated to 50 r/min (at 1)), and will turn off when the servo motor is accelerated to 70 r/min again (at 2)). ZSP will turn on when the servo motor is decelerated again to 50 r/min (at 3)), and will turn off when the servo motor speed has reached -70 r/min (at 4)). The range from the point when the servo motor speed has reached on level, and ZSP turns on, to the point when it is accelerated again and has reached off level is called hysteresis width. Hysteresis width is 20 r/min for this driver.</p>
Limiting torque	TLC	When the torque reaches the torque limit value during torque generation, TLC will turn on. When the servo is off, TLC will be turned off. This device cannot be used in the torque mode.
Warning	WNG	When warning has occurred, WNG turns on. When a warning is not occurring, WNG will turn off in 2.5 s to 3.5 s after power-on.
Battery warning	BWNG	BWNG turns on when [AL. 92 Battery cable disconnection warning] or [AL. 9F Battery warning] has occurred. When the battery warning is not occurring, BWNG will turn off in 2.5 s to 3.5 s after power-on.
Variable gain selection	CDPS	CDPS will turn on during variable gain.
Absolute position undetermined	ABSV	ABSV turns on when the absolute position is undetermined. The device cannot be used in the velocity mode and torque mode.
During tough drive	MTTR	When a tough drive is enabled in [Pr. PA20], activating the instantaneous power failure tough drive will turn on MTTR.
During fully closed loop control	CLDS	CLDS turns on during fully closed loop control.
General-purpose output A	DOA	The pins to which this device is assigned can be switched on/off with "Digital outputs" of the object. For details, refer to chapter 18,19,20.
General-purpose output B	DOB	
General-purpose output C	DOC	

3. SIGNALS AND WIRING

3.5.3 Output signal

Signal name	Symbol	Connector pin No.	Function and application
Encoder A-phase pulse (differential line driver)	LA LAR	CN3-6 CN3-16	These devices output pulses of encoder output set in [Pr. PA15] and [Pr. PA16] in the differential line driver type. In CCW rotation of the servo motor, the encoder B-phase pulse lags the encoder A-phase pulse by a phase angle of $\pi/2$.
Encoder B-phase pulse (differential line driver)	LB LBR	CN3-7 CN3-17	The relation between rotation direction and phase difference of the A-phase and B-phase pulses can be changed with [Pr. PC03]. Output pulse specification, dividing ratio setting, and electronic gear setting can be selected.
Encoder Z-phase pulse (differential line driver)	LZ LZR	CN3-8 CN3-18	The encoder zero-point signal is output in the differential line driver type. One pulse is output per servo motor revolution. This turns on when the zero-point position is reached. (negative logic) The minimum pulse width is about 400 μ s. For home position return using this pulse, set the creep speed to 100 r/min or less.
Analog monitor 1	MO1	CN3-4	This is used to output the data set in [Pr. PC09] to between MO1 and LG in terms of voltage. Resolution: 10 bits or equivalent
Analog monitor 2	MO2	CN3-14	This signal output the data set in [Pr. PC10] to between MO2 and LG in terms of voltage. Resolution: 10 bits or equivalent

3.5.4 Power supply

Signal name	Symbol	Connector pin No.	Function and application
Digital I/F power supply input	DICOM	CN3-5	Input 24 V DC (24 V DC \pm 10% 300 mA) for I/O interface. The power supply capacity changes depending on the number of I/O interface points to be used. For sink interface, connect + of 24 V DC external power supply. For source interface, connect - of 24 V DC external power supply.
Digital I/F common	DOCOM	CN3-3	Common terminal of input signal such as EM2 of the driver. This is separated from LG. For sink interface, connect - of 24 V DC external power supply. For source interface, connect + of 24 V DC external power supply.
Monitor common	LG	CN3-11	Common terminal of MO1 and MO2.
Shield	SD	Plate	Connect the external conductor of the shielded wire.

3. SIGNALS AND WIRING

3.6 Forced stop deceleration function

POINT
●When alarms not related to the forced stop function occur, control of motor deceleration cannot be guaranteed. (Refer to chapter 8.)
●When network communication is shut-off, forced stop deceleration will operate. (Refer to section 3.7.1 (3).)
●In the torque mode, the forced stop deceleration function is not available.
●Disable the forced stop deceleration function for a machine in which multiple axes are connected together, such as a tandem structure. If an alarm occurs with the forced stop deceleration function disabled, the servo motor will stop with the dynamic brake.
●Keep the servo-on command (from upper side) and ready-on command (from upper side) on while EM2 (Forced stop 2) is off. When the servo-on command (from upper side) or ready-on command (from upper side) is off, forced stop deceleration, base circuit shut-off delay time, and vertical axis freefall prevention do not function.

3.6.1 Forced stop deceleration function

When EM2 is turned off, dynamic brake will start to stop the servo motor after forced stop deceleration.

During this sequence, the display shows [AL. E6 Servo forced stop warning].

During normal operation, do not use EM2 (Forced stop 2) to alternate stop and drive. The driver life may be shortened.

(1) Connection diagram

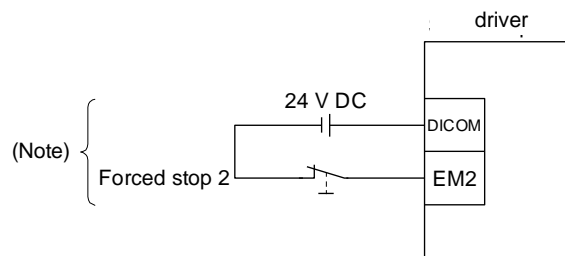

Note. This diagram shows sink I/O interface. For source I/O interface, refer to section 3.8.3.

3. SIGNALS AND WIRING

(2) Timing chart

When EM2 (Forced stop 2) is turned off, the motor will decelerate according to [Pr. PC24 Forced stop deceleration time constant]. Once the motor speed is below [Pr. PC07 Zero speed], base power is cut and the dynamic brake activates.

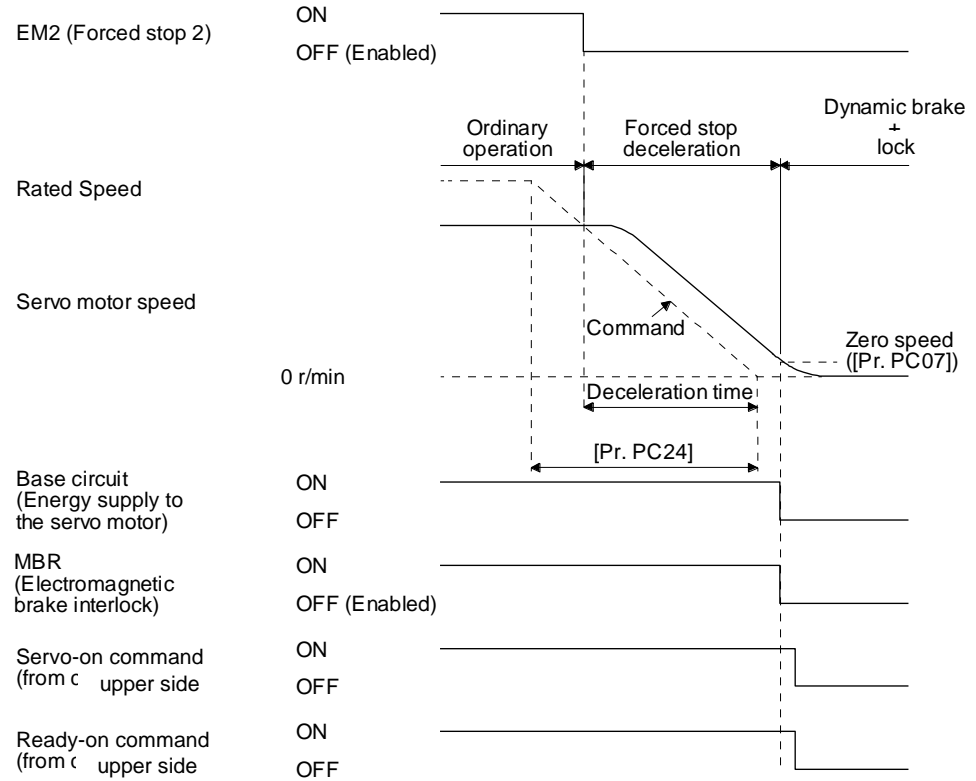

3. SIGNALS AND WIRING

3.6.2 Base circuit shut-off delay time function

The base circuit shut-off delay time function is used to prevent vertical axis from dropping at a forced stop (EM2 goes off), alarm occurrence, or network communication shut-off due to delay time of the lock. Set the time from MBR (Lock interlock) off to base circuit shut-off with [Pr. PC02].

(1) Timing chart

When EM2 (Forced stop 2) turns off or an alarm occurs during driving, the servo motor will decelerate based on the deceleration time constant. MBR (Lock interlock) will turn off, and then after the delay time set in [Pr. PC02], the driver will be base circuit shut-off status.

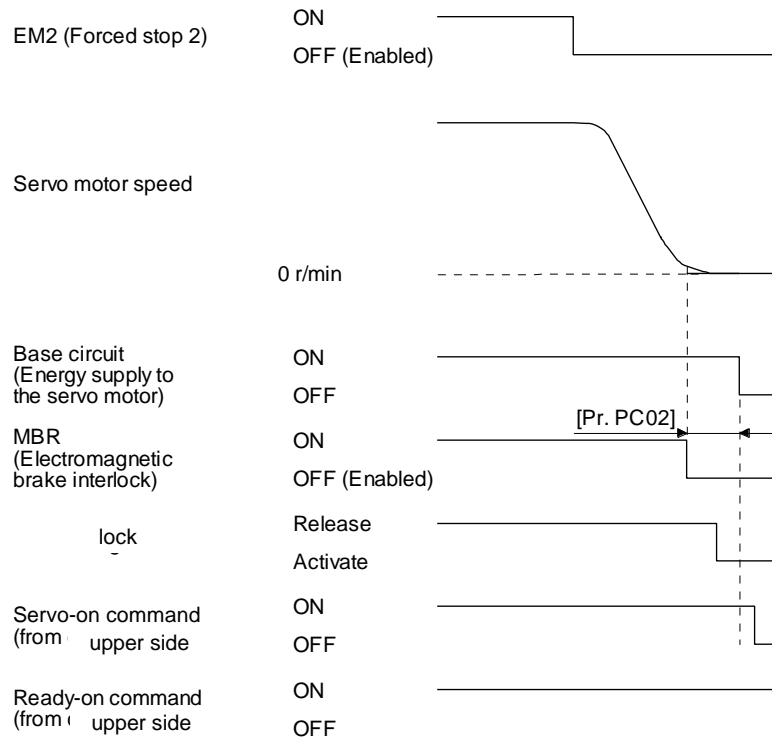

(2) Adjustment

While the servo motor is stopped, turn off EM2 (Forced stop 2), adjust the base circuit shut-off delay time in [Pr. PC02], and set the value to approximately 1.5 times of the smallest delay time in which the servo motor shaft does not freefall.

3. SIGNALS AND WIRING

3.6.3 Vertical axis freefall prevention function

The vertical axis freefall prevention function avoids machine damage by pulling up the shaft slightly like the following case.

When the servo motor is used for operating vertical axis, the servo motor lock and the base circuit shut-off delay time function avoid dropping axis at forced stop. However, the functions may not avoid dropping axis a few μm due to the backlash of the servo motor lock.

The vertical axis freefall prevention function is enabled with the following conditions.

- Other than "0" is set to [Pr. PC31 Vertical axis freefall prevention compensation amount].
- EM2 (Forced stop 2) turned off, an alarm occurred, or network communication shut-off occurred while the servo motor speed is zero speed or less.
- The base circuit shut-off delay time function is enabled.

(1) Timing chart

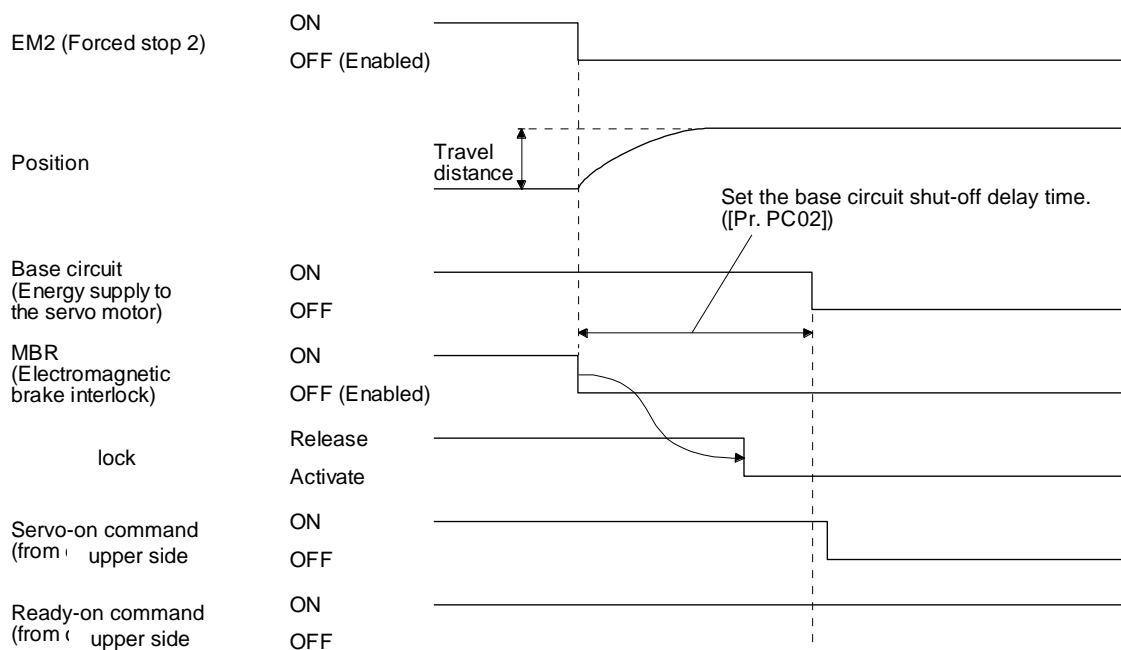

(2) Adjustment

- Set the freefall prevention compensation amount in [Pr. PC31].
- While the servo motor is stopped, turn off the EM2 (Forced stop 2). Adjust the base circuit shut-off delay time in [Pr. PC02] in accordance with the travel distance ([Pr. PC31]). Adjust it considering the freefall prevention compensation amount by checking the servo motor speed, torque ripple, etc.

3.6.4 Residual risks of the forced stop function (EM2)

- (1) The forced stop function is not available for alarms that activate the dynamic brake when the alarms occur.
- (2) When an alarm that activates the dynamic brake during forced stop deceleration occurs, the braking distance until the servo motor stops will be longer than that of normal forced stop deceleration without the dynamic brake.
- (3) If STO is turned off during forced stop deceleration, [AL. 63 STO timing error] will occur.

3. SIGNALS AND WIRING

3.7 Alarm occurrence timing chart

 CAUTION	<ul style="list-style-type: none"> ● When an alarm has occurred, remove its cause, make sure that the operation signal is not being input, ensure safety, and reset the alarm before restarting operation.
--	---

POINT	<ul style="list-style-type: none"> ● In the torque mode, the forced stop deceleration function is not available.
--------------	---

To deactivate the alarm, cycle the control circuit power, give the error reset command from the upper side, or perform network communication reset. However, the alarm cannot be deactivated unless its cause is removed.

3.7.1 When you use the forced stop deceleration function

POINT	<ul style="list-style-type: none"> ● To enable the function, set "2 _ _ _ (initial value)" in [Pr. PA04]. ● If an alarm occurs with the forced stop deceleration function disabled, the servo motor will stop with the dynamic brake.
--------------	---

(1) When the forced stop deceleration function is enabled

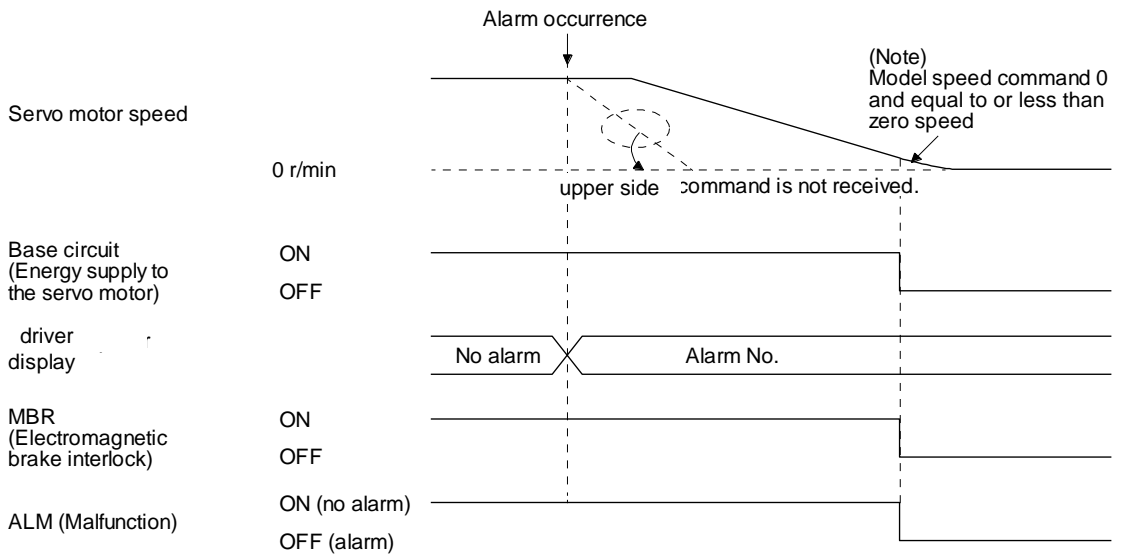

Note. The model speed command is a speed command generated in the driver for forced stop deceleration of the servo motor.

3. SIGNALS AND WIRING

(2) When the forced stop deceleration function is not enabled

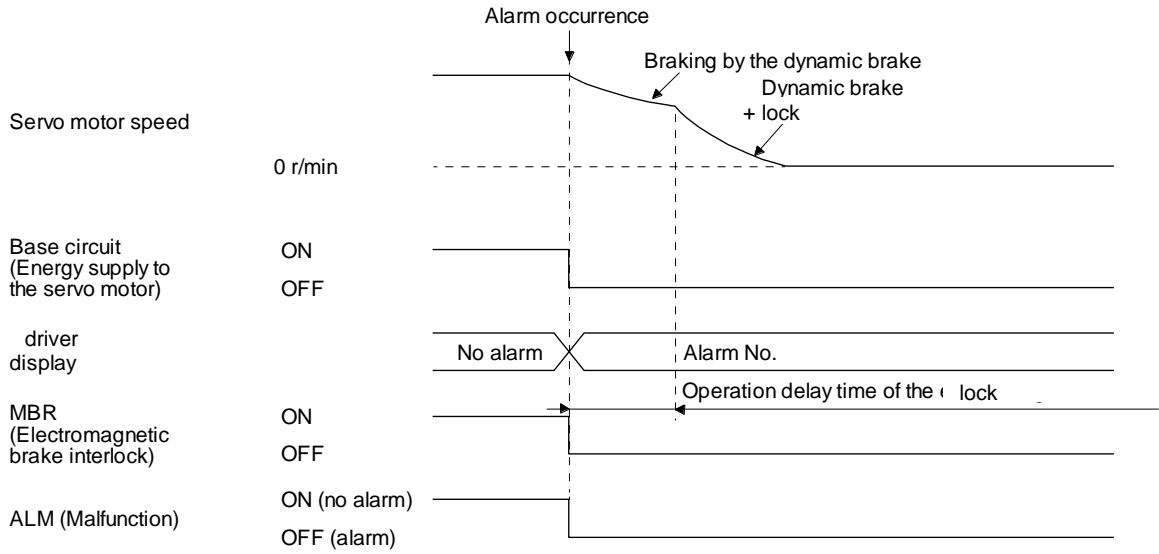

(3) When network communication is shut-off

The dynamic brake may operate depending on the communication shut-off status.

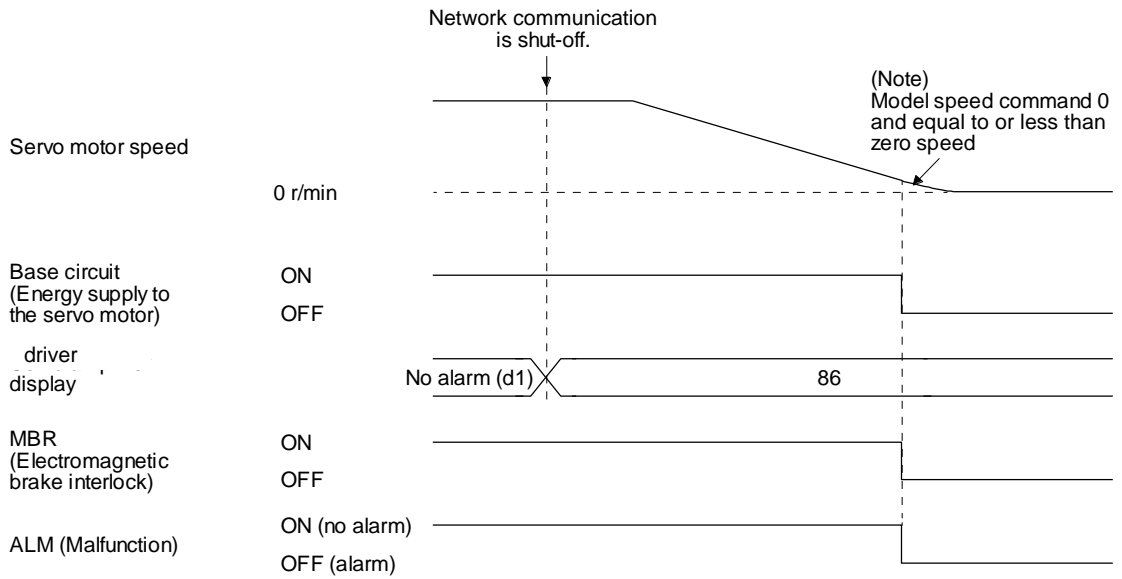

Note. The model speed command is a speed command generated in the driver for forced stop deceleration of the servo motor.

3.7.2 When you do not use the forced stop deceleration function

POINT
● To disable the function, set "0 _ _ _" in [Pr. PA04].

The timing chart that shows the servo motor condition when an alarm or network communication shut-off occurs is the same as section 3.7.1 (2).

3. SIGNALS AND WIRING

3.8 Interfaces

3.8.1 Internal connection diagram

POINT

● Refer to section 13.3.1 for the CN8 connector.

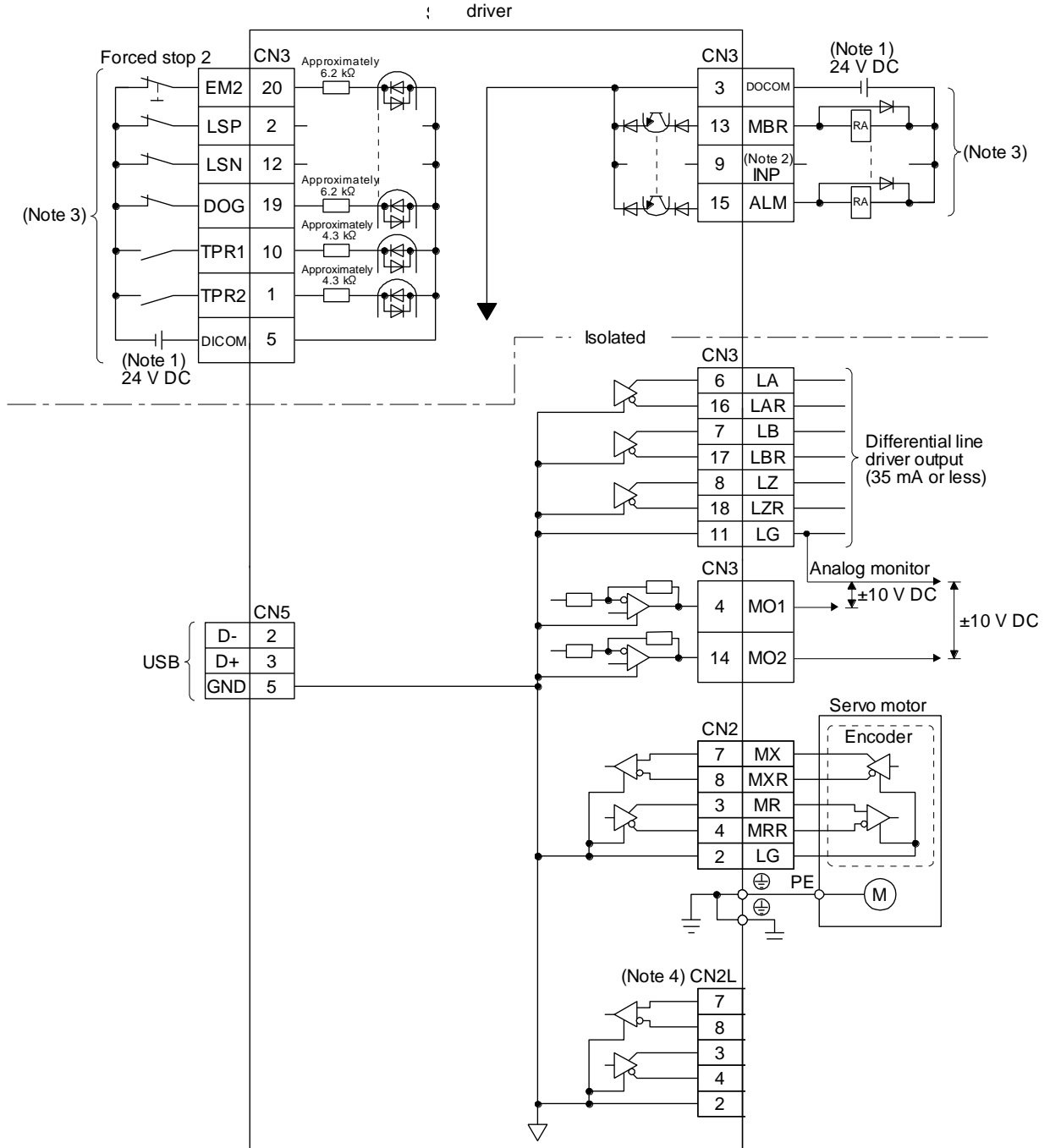

Note 1. The illustration of the 24 V DC power supply is divided between input signal and output signal for convenience. However, they can be configured by one.

Note 2. The signal cannot be used in the velocity mode and torque mode.

Note 3. This diagram shows sink I/O interface. For source I/O interface, refer to section 3.8.3.

Note 4. Do not use it.

3. SIGNALS AND WIRING

3.8.2 Detailed explanation of interfaces

This section provides the details of the I/O signal interfaces (refer to the I/O division in the table) given in section 3.5. Refer to this section and make connection with the external device.

(1) Digital input interface DI-1

This is an input circuit whose photocoupler cathode side is input terminal. Transmit signals from sink (open-collector) type transistor output, relay switch, etc. The following is a connection diagram for sink input. Refer to section 3.8.3 for source input.

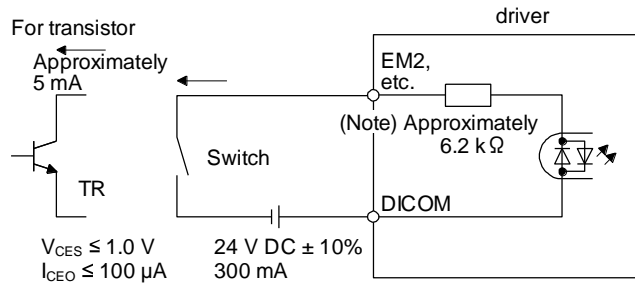

Note. It will be approximately 4.3 kΩ for interface of CN3-1 and CN3-10 pins.

(2) Digital output interface DO-1

This is a circuit in which the collector of the output transistor is the output terminal. When the output transistor is turned on, the current will flow to the collector terminal.

A lamp, relay or photocoupler can be driven. Install a diode (D) for an inductive load, or install an inrush current suppressing resistor (R) for a lamp load.

(Rated current: 40 mA or less, maximum current: 50 mA or less, inrush current: 100 mA or less) A maximum of 2.6 V voltage drop occurs in the driver.

The following shows a connection diagram for sink output. Refer to section 3.8.3 for source output.

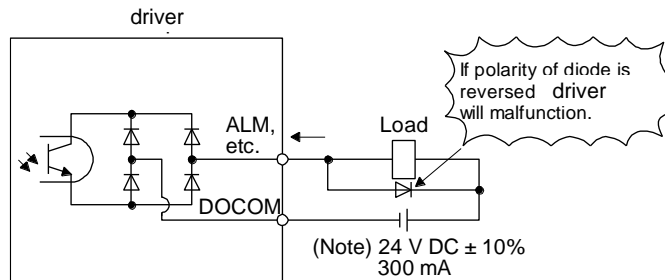

Note. If the voltage drop (maximum of 2.6 V) interferes with the relay operation, apply high voltage (maximum of 26.4 V) from external source.

3. SIGNALS AND WIRING

(3) Encoder output pulses DO-2 (differential line driver type)

(a) Interface

Maximum output current: 35 mA

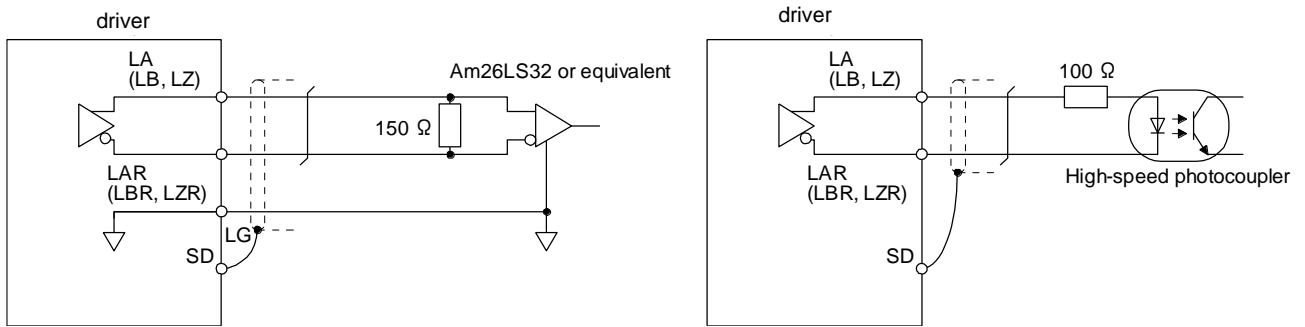

(b) Output pulse

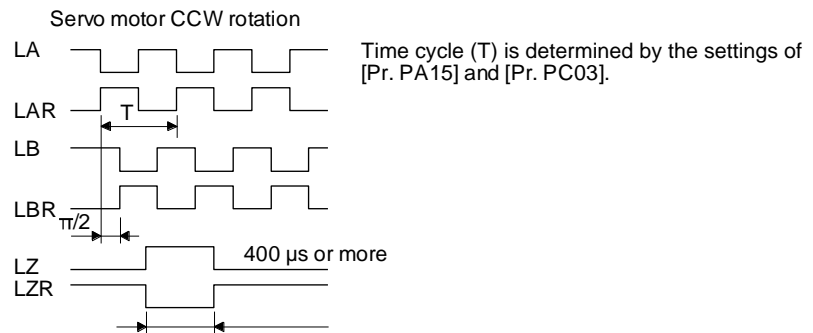

(4) Analog output

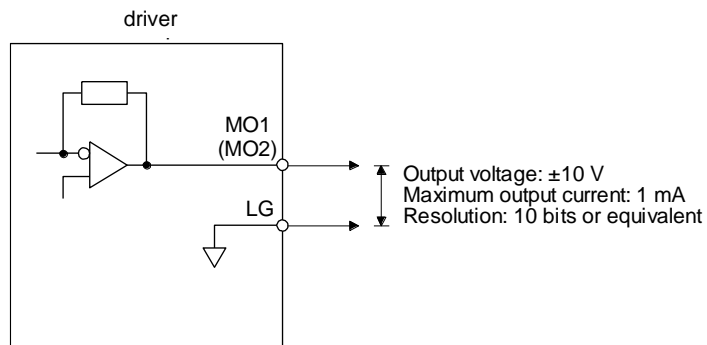

Note. Output voltage range varies depending on the output contents.

3. SIGNALS AND WIRING

3.8.3 Source I/O interfaces

In this driver, source type I/O interfaces can be used.

(1) Digital input interface DI-1

This is an input circuit whose photocoupler anode side is input terminal. Transmit signals from source (open-collector) type transistor output, relay switch, etc.

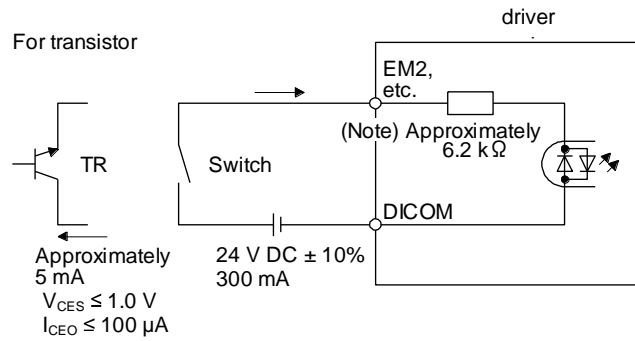

Note. It will be approximately 4.3 k Ω for interface of CN3-1 and CN3-10 pins.

(2) Digital output interface DO-1

This is a circuit in which the emitter of the output transistor is the output terminal. When the output transistor is turned on, the current will flow from the output terminal to a load.

A maximum of 2.6 V voltage drop occurs in the driver.

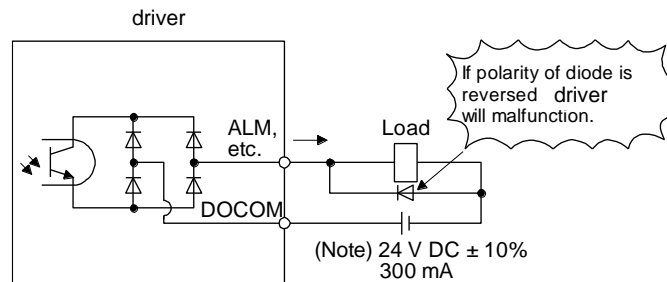

Note. If the voltage drop (maximum of 2.6 V) interferes with the relay operation, apply high voltage (maximum of 26.4 V) from external source.

3. SIGNALS AND WIRING

3.9 Servo motor with a lock 3.9.1 Safety precautions

● Configure a lock circuit which is interlocked with an external emergency stop switch.

Contacts must be opened when ALM (Malfunction) and MBR (Electromagnetic brake interlock) turns off.

Contacts must be opened with the EMG stop switch.

Refer to section 3.10.3 when wiring for the circuit configuration.

CAUTION

- The lock is provided for holding purpose and must not be used for ordinary braking.
- Before operating the servo motor, be sure to confirm that the lock operates properly.
- Do not use the 24 V DC interface power supply for the lock. Always use the power supply designed exclusively for the lock. Otherwise, it may cause a malfunction.
- When using EM2 (Forced stop 2), use MBR (Lock interlock) for operating the lock. Operating the lock without using MBR during deceleration to a stop will saturate servo motor torques at the maximum value due to brake torque of the lock. This can result in delay of the deceleration to a stop from a set value.

POINT

- Refer to Chapter 15 for specifications such as the power supply capacity and operation delay time of the lock.
- Refer to Chapter 15 for the selection of a surge absorber for the lock.

Note the following when the servo motor with an lock is used.

- 1) The lock will operate when the power (24 V DC) turns off.
- 2) Turn off SON (Servo-on) after the servo motor stopped.

(1) Connection diagram

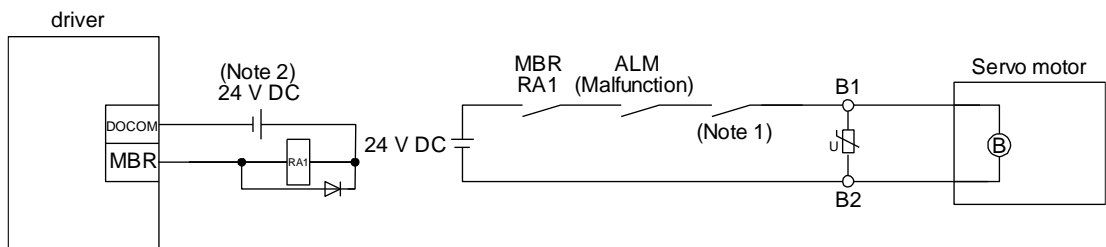

- Note 1. Create the circuit in order to shut off by interlocking with the emergency stop switch.
2. Do not use the 24 V DC interface power supply for the lock.

(2) Setting

In [Pr. PC02 Lock sequence output], set a delay time (Tb) from MBR (Lock interlock) off to base circuit shut-off at a servo-off as in the timing chart in section 3.9.2.

3. SIGNALS AND WIRING

3.9.2 Timing chart

(1) When you use the forced stop deceleration function

POINT
●To enable the function, set "2 _ _ _ (initial value)" in [Pr. PA04].

(a) Servo-on command (from upper side) on/off

POINT
●Keep the ready-on command (from upper side) on while the servo-on command (from upper side) is off. When the ready-off command (from upper side) is off, Tb [Pr. PC02 Lock sequence output] does not function.

When servo-on command is turned off, the servo lock will be released after Tb [ms], and the servo motor will coast. If the lock is enabled during servo-lock, the brake life may be shorter. Therefore, set Tb about 1.5 times of the minimum delay time where the moving part will not drop down for a vertical axis system, etc.

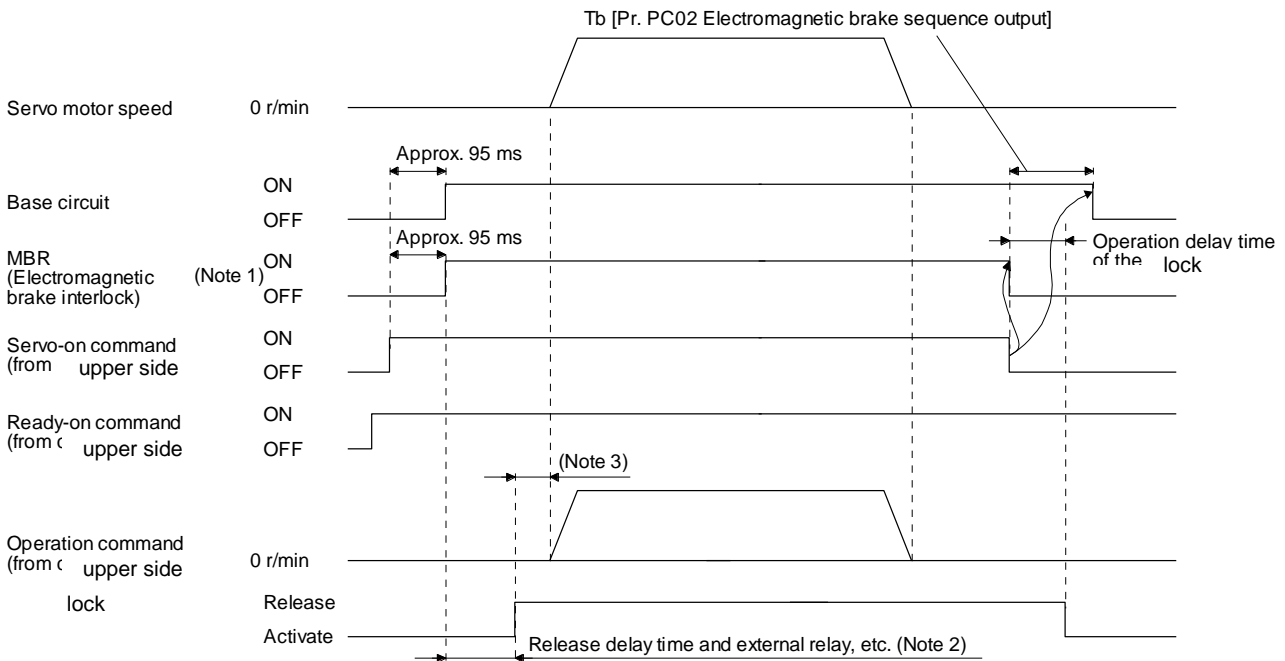

Note 1. ON: Lock is not activated.

OFF: Lock is activated.

2. Lock is released after delaying for the release delay time of lock and operation time of external circuit relay. For the release delay time of lock, refer to chapter 15.

3. Give the operation command from the upper side after the lock is released.

3. SIGNALS AND WIRING

(b) Off/on of the quick stop command (from upper side) or EM2 (Forced stop 2)

POINT

- In the torque mode, the forced stop deceleration function is not available.
- Keep the servo-on command (from upper side) and ready-on command (from upper side) on while the quick stop command (from upper side) or the EM2 (Forced stop 2) is off. When the ready-off command (from upper side) is off, Tb [Pr. PC02 Lock sequence output] does not function.

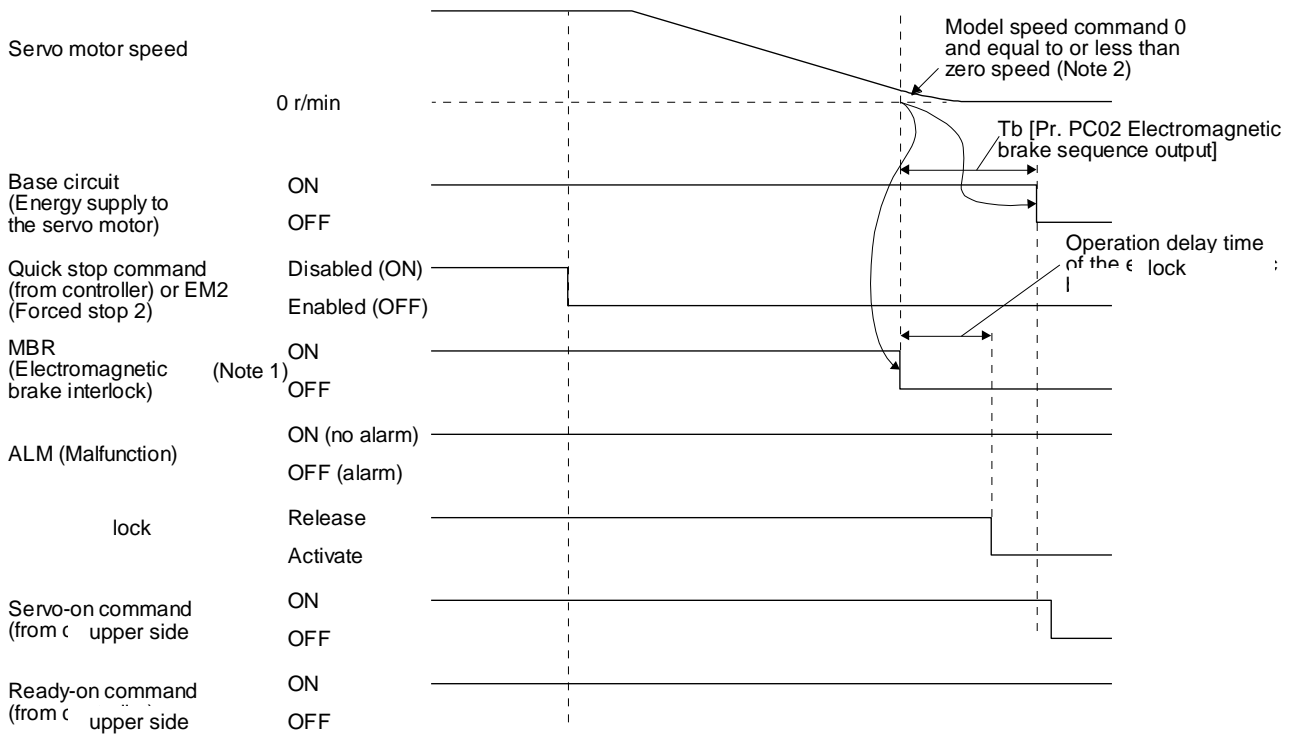

Note 1. ON: Lock is not activated.
 OFF: Lock is activated.

2. The model speed command is a speed command generated in the driver for forced stop deceleration of the servo motor.

3. SIGNALS AND WIRING

(c) Alarm occurrence

1) When the forced stop deceleration function is enabled

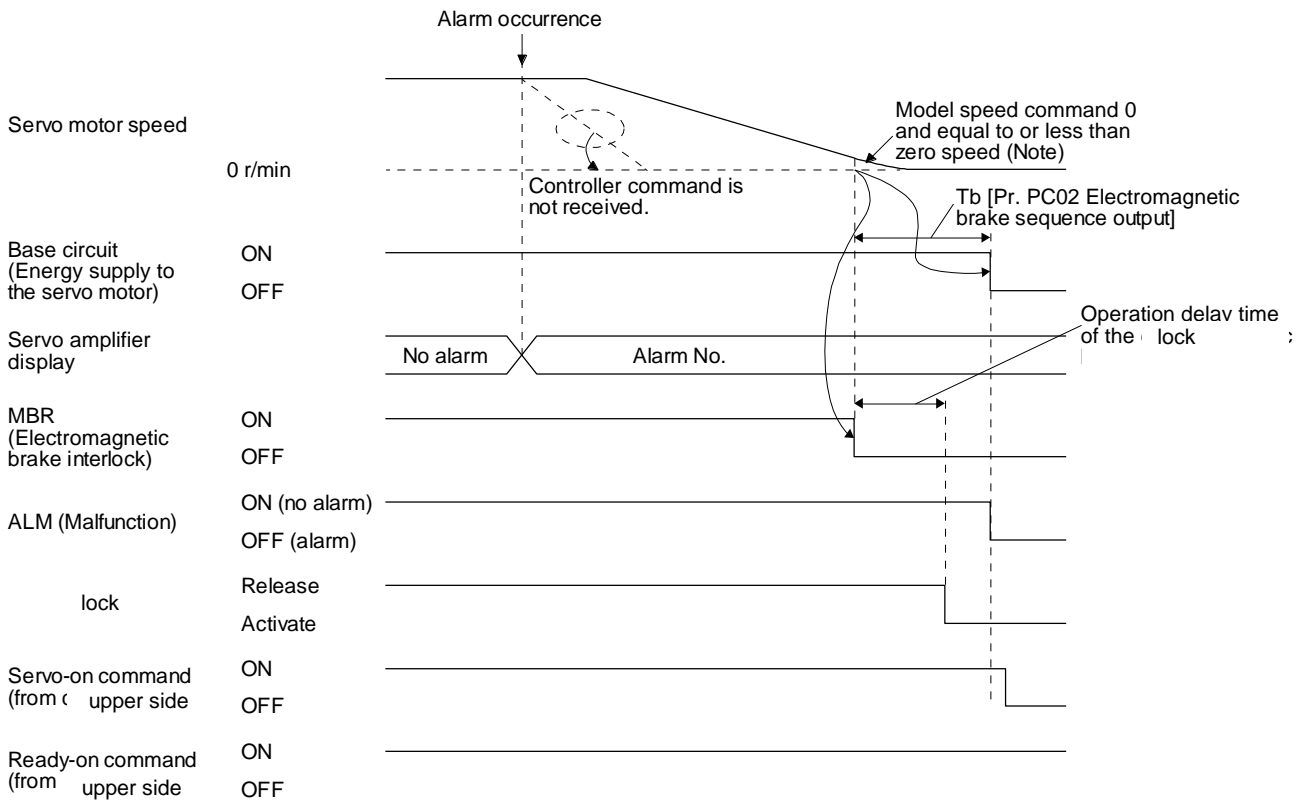

Note. The model speed command is a speed command generated in the driver for forced stop deceleration of the servo motor.

2) When the forced stop deceleration function is disabled The operation status is the same as section 3.7.1 (2).

3. SIGNALS AND WIRING

3) When network communication shut-off occurs

The dynamic brake may operate depending on the communication shut-off status.

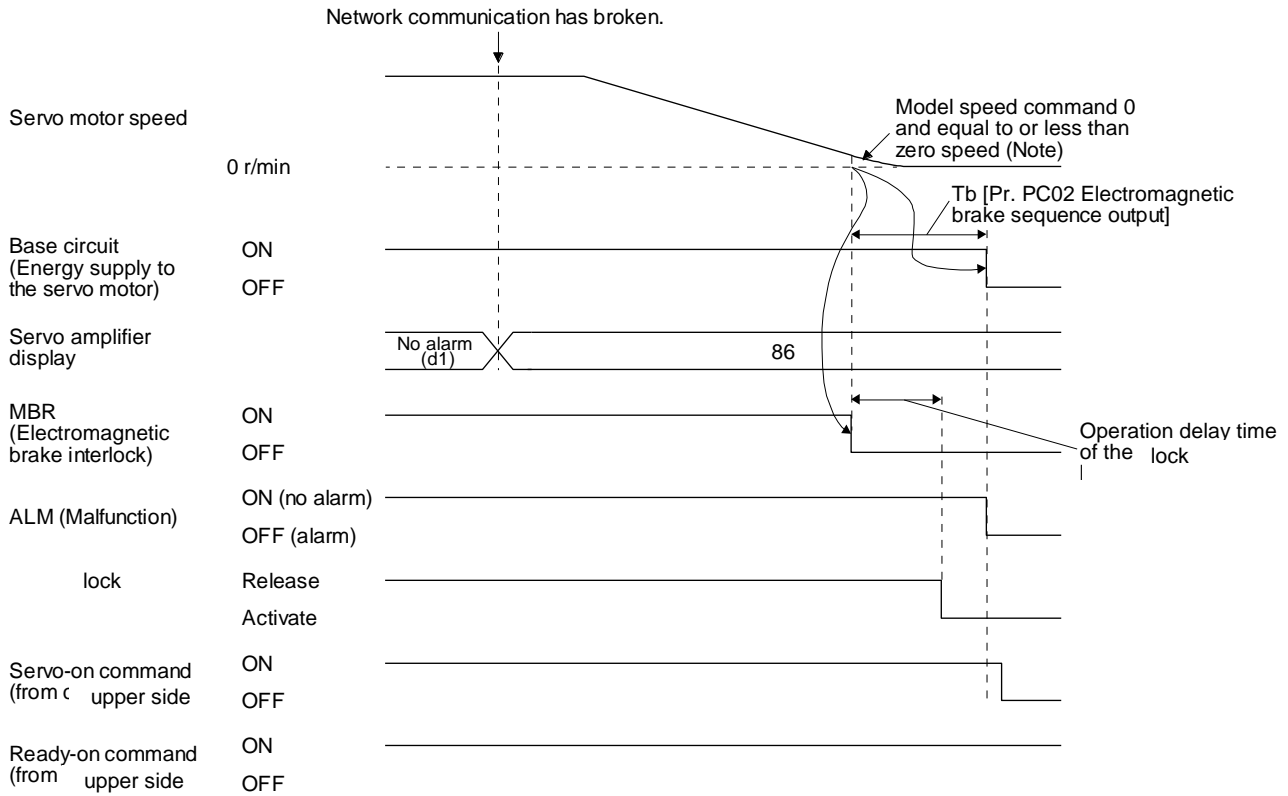

Note. The model speed command is a speed command generated in the driver for forced stop deceleration of the servo motor.

(d) Both main and control circuit power supplies off

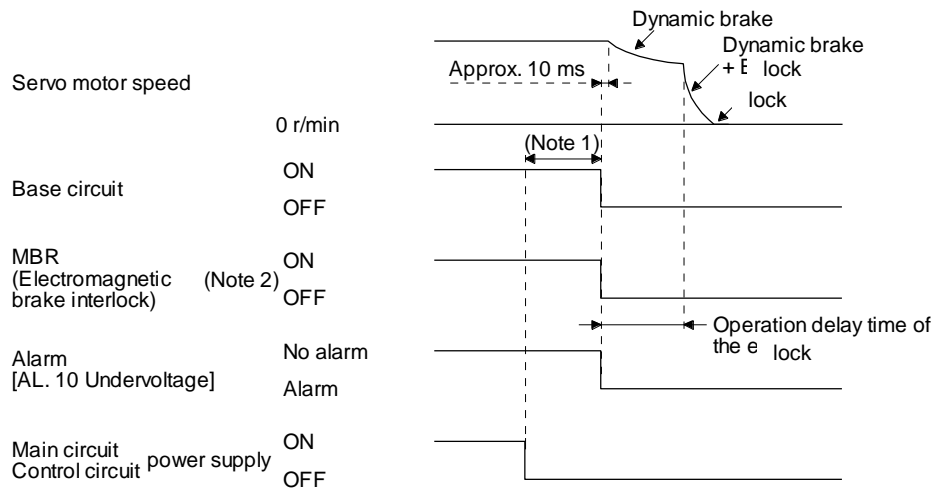

Note 1. Variable according to the operation status.

2. ON: Lock is not activated.

OFF: Lock is activated.

3. SIGNALS AND WIRING

(e) Main circuit power supply off during control circuit power supply on

POINT
 ● In the torque mode, the forced stop deceleration function is not available.

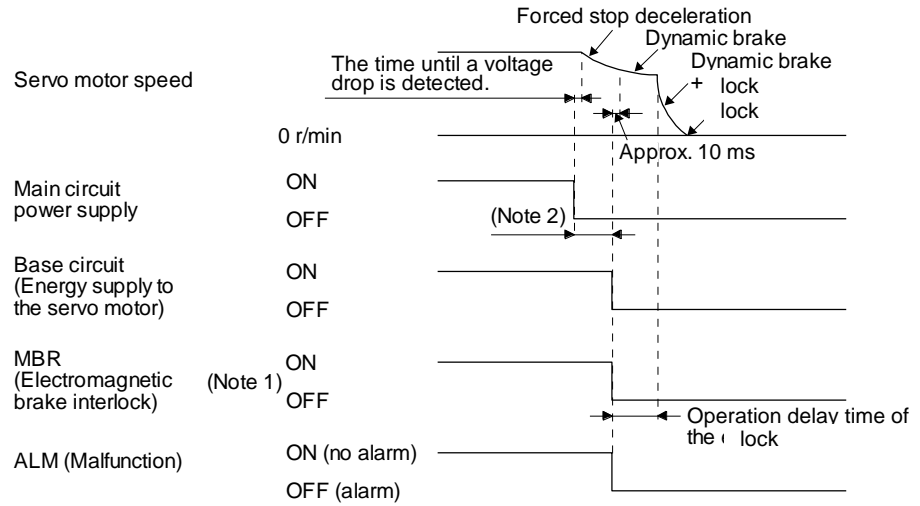

- Note 1. ON: Lock is not activated.
 OFF: Lock is activated.
2. Variable according to the operation status.

(f) Ready-off command from upper side

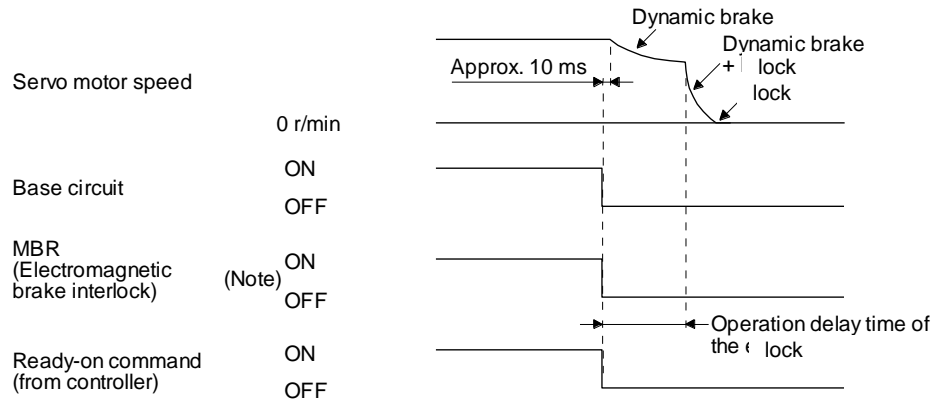

- Note. ON: Lock is not activated.
 OFF: Lock is activated.

3. SIGNALS AND WIRING

(2) When you do not use the forced stop deceleration function

POINT
●To disable the function, set "0 _ _ _" in [Pr. PA04].

(a) Servo-on command (from upper side) on/off
It is the same as (1) (a) in this section.

(b) Off/on of the quick stop command (from upper side) or EM1 (Forced stop 1)

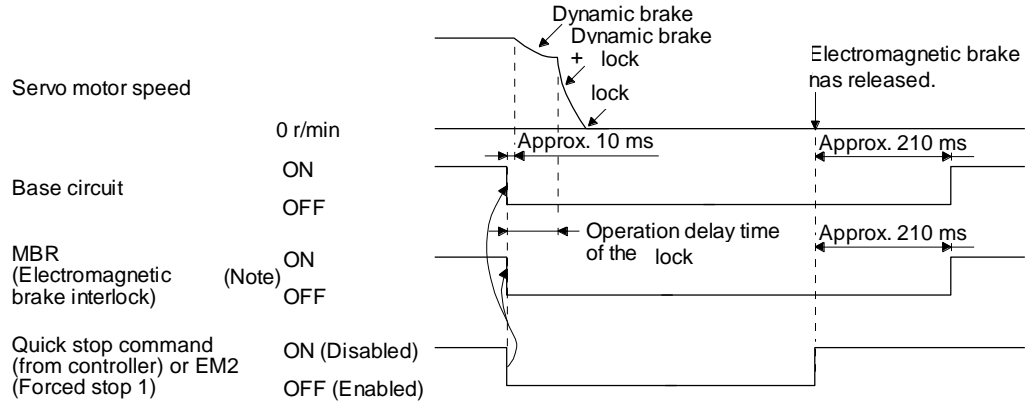

Note. ON: Lock is not activated.
OFF: Lock is activated.

(c) Alarm occurrence

The operation status during an alarm is the same as section 3.7.2.

(d) Both main and control circuit power supplies off

It is the same as (1) (d) in this section.

(e) Main circuit power supply off during control circuit power supply on

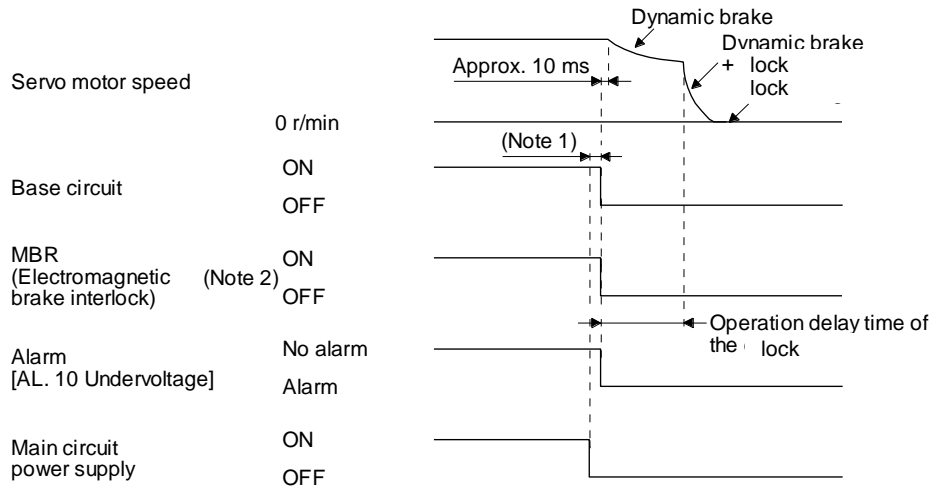

Note 1. Variable according to the operation status.
Note 2. ON: Lock is not activated.
OFF: Lock is activated.

(f) Ready-off command from upper side

It is the same as (1) (f) in this section.

3. SIGNALS AND WIRING

3.9.3 Wiring diagrams (LE-□-□ series servo motor)

(1) When cable length is 10m or less

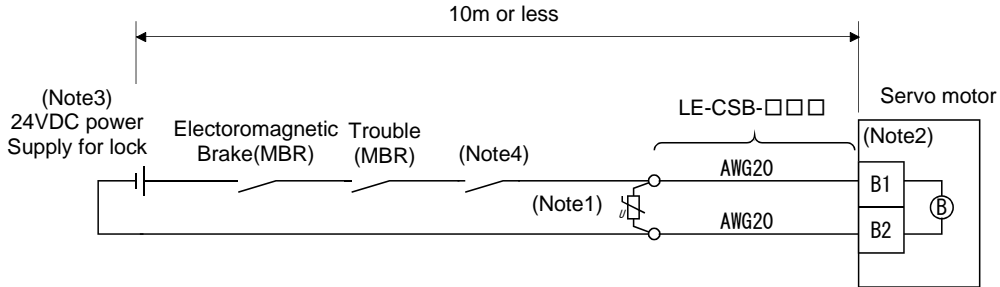

- Note 1. Connect a surge absorber as close to the servo motor as possible.
2. There is no polarity in lock terminals (B1 and B2).
 3. Do not share the lock power supply with the interface 24VDC power supply.
 4. Shut off the circuit in conjunction with the emergency stop switch.

When fabricating the lock cable LE-CSB-R□□, refer to section 11.1.6.

(2) When cable length exceeds 10m

When the cable length exceeds 10m, fabricate an extension cable as shown below on the customer side. In this case, the lock cable should be within 2m long.

Refer to section 11.5 for the wire used for the extension cable.

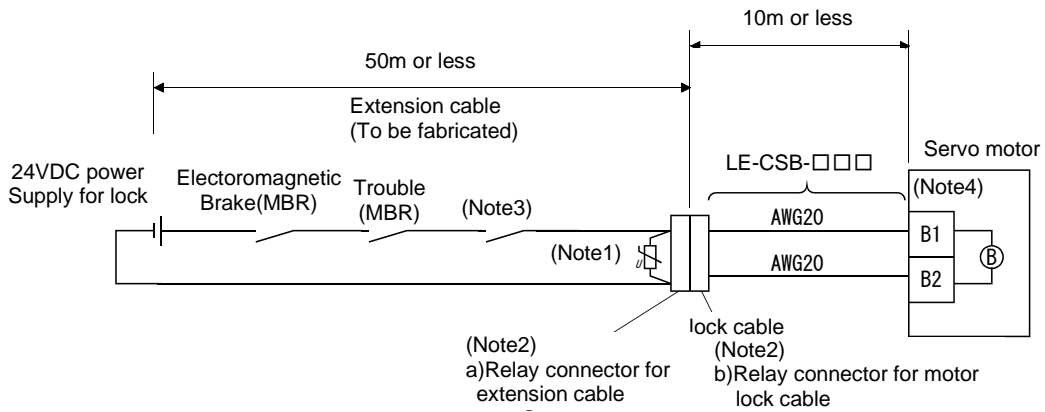

- Note 1. Connect a surge absorber as close to the servo motor as possible.
2. Use of the following connectors is recommended when ingress protection (IP65) is necessary.

Relay connector	Description	Protective structure
a) Relay connector for extension cable	CM10-CR2P-* (DDK) Wire size: S, M, L	IP65
b) Relay connector for motor lock cable	CM10-SP2S-* (DDK) Wire size: S, M, L	IP65

3. Shut off the circuit in conjunction with the emergency stop switch.
4. There is no polarity in lock terminals (B1 and B2).
5. Do not share the lock power supply with the interface 24VDC power supply.

3. SIGNALS AND WIRING

3.10 Grounding

WARNING ● Ground the driver and servo motor securely.
● To prevent an electric shock, always connect the protective earth (PE) terminal (marked ⊕) of the driver to the protective earth (PE) of the cabinet.

The driver switches the power transistor on-off to supply power to the servo motor. Depending on the wiring and ground cable routing, the driver may be affected by the switching noise (due to di/dt and dv/dt) of the transistor. To prevent such a fault, refer to the following diagram and always ground.

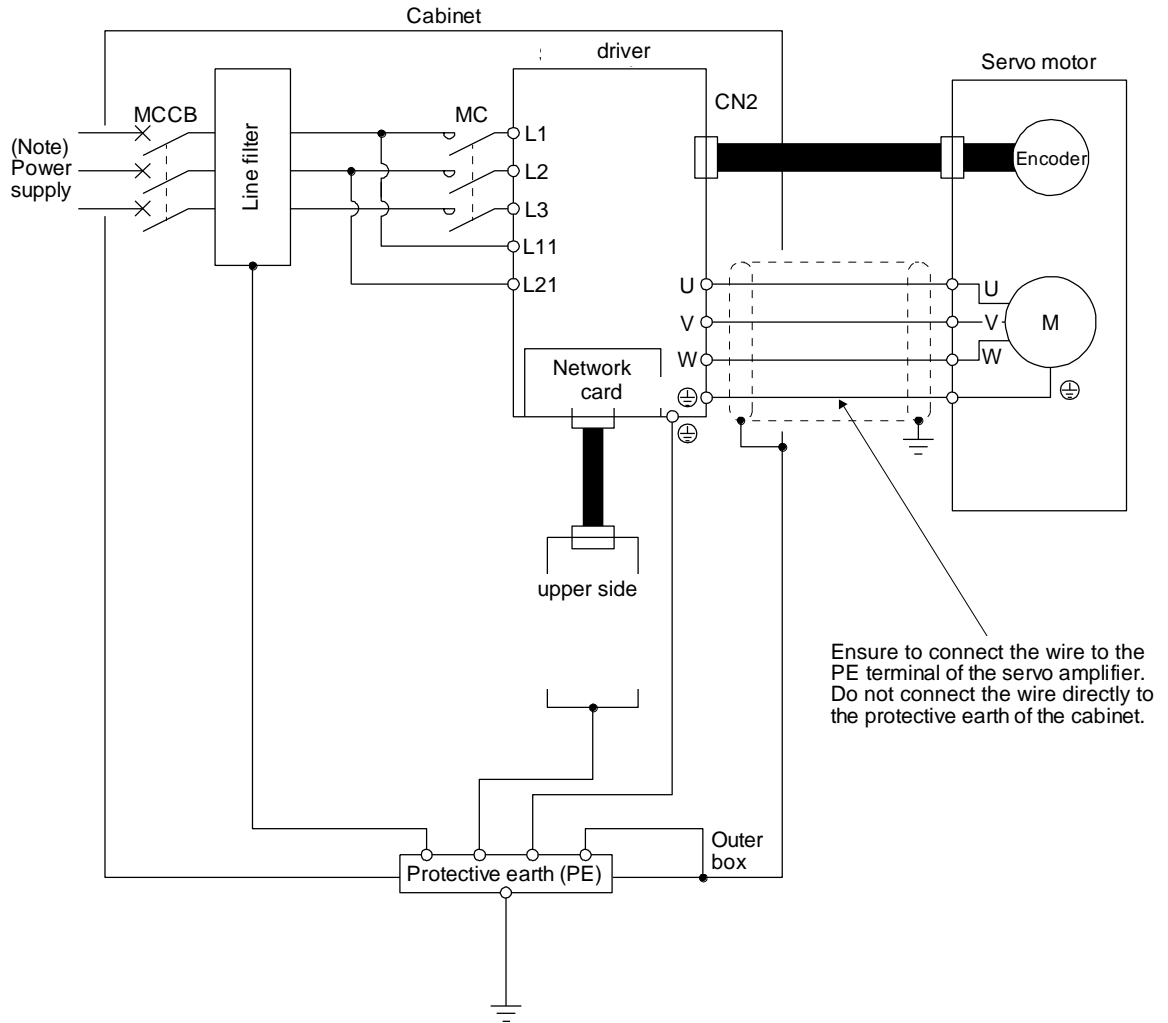

Note. For the power supply specifications, refer to section 1.3.

4. STARTUP

4. STARTUP	2
4.1 Switching power on for the first time.....	3
4.1.1 Startup procedure	3
4.1.2 Wiring check.....	4
4.1.3 Surrounding environment.....	5
4.2 Startup	5
4.3 Switch setting and display of the driver	7
4.3.1 Switches.....	7
4.3.2 Scrolling display.....	8
4.3.3 Status display of an axis.....	10
4.4 Test operation	12
4.5 Test operation mode	12
4.5.1 Test operation mode in Setup software (MR Configurator2™)	13
4.5.2 Motor-less operation in upper side	17

4. STARTUP

4. STARTUP

WARNING

- When executing a test run, follow the notice and procedures in this manual. Otherwise, it may cause a malfunction, damage to the machine, or injury.
- Do not operate the switches with wet hands. Otherwise, it may cause an electric shock.

CAUTION

- Before starting operation, check the parameters. Improper settings may cause some machines to operate unexpectedly.
- The driver heat sink, regenerative resistor, servo motor, etc., may be hot while the power is on and for some time after power-off. Take safety measures such as providing covers to avoid accidentally touching them by hands and parts such as cables.
- During operation, never touch the rotor of the servo motor. Otherwise, it may cause injury.
- Before wiring, switch operation, etc., eliminate static electricity. Otherwise, it may cause a malfunction.

4. STARTUP

4.1 Switching power on for the first time

POINT
●When using the driver in the point table method, refer to section 16.2.
●When using the driver in the indexer method, refer to section 17.2.

When switching power on for the first time, follow this section to make a startup.

4.1.1 Startup procedure

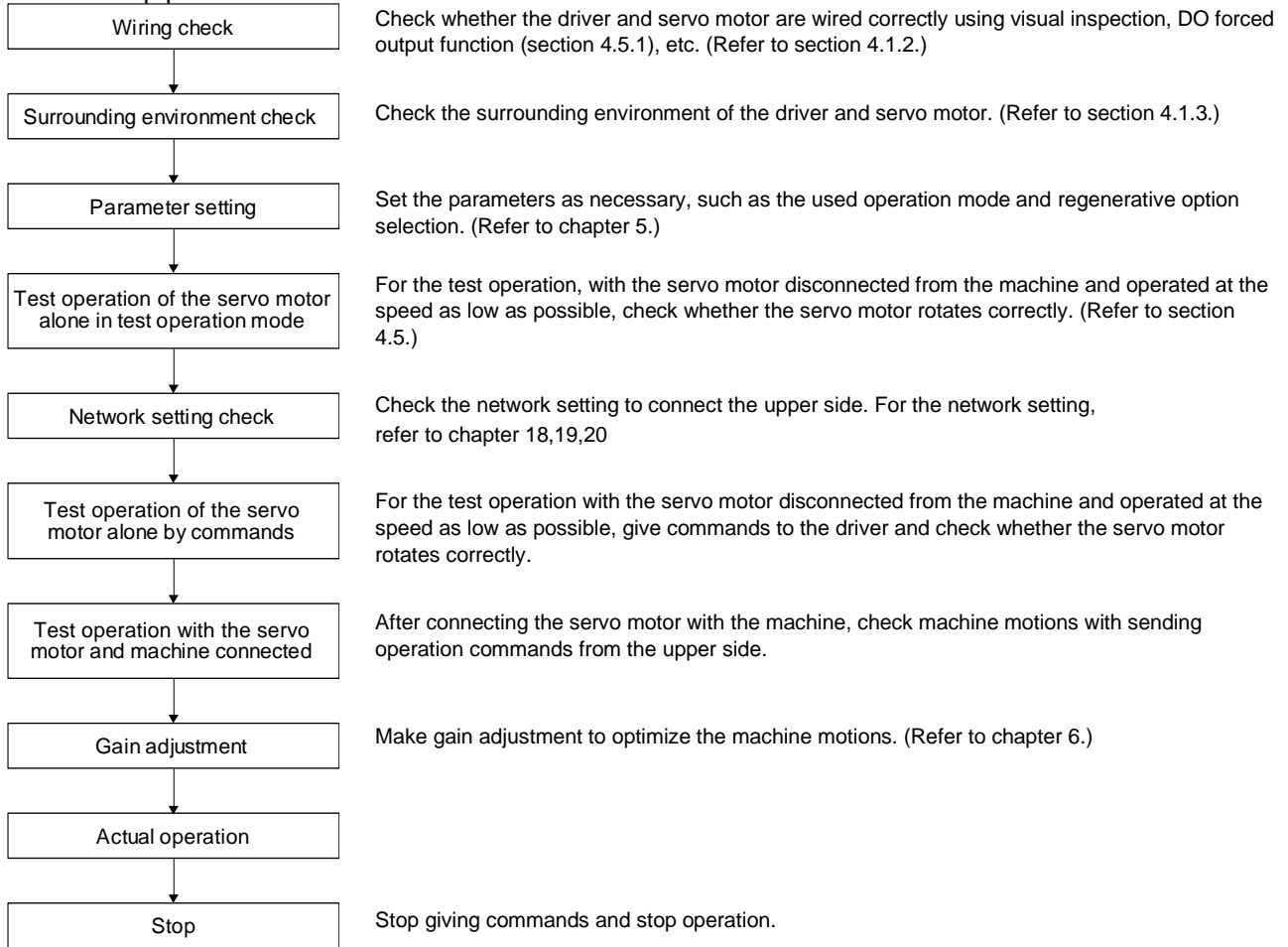

4. STARTUP

4.1.2 Wiring check

(1) Power supply system wiring

Before switching on the main circuit and control circuit power supplies, check the following items.

(a) Power supply system wiring

- 1) The power supplied to the power input terminals (L1/L2/L3/L11/L21) of the driver should satisfy the defined specifications. (Refer to section 1.3.)
- 2) between P3 and P4 should be connected.

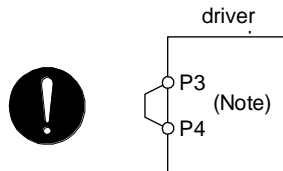

(b) Connection of driver and servo motor

- 1) The driver power output (U/V/W) should match in phase with the servo motor power input terminals (U/V/W).

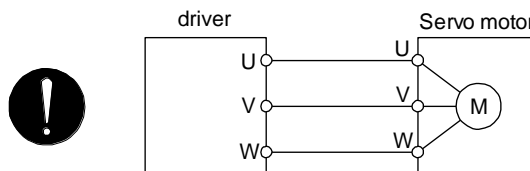

- 2) The power supplied to the driver should not be connected to the servo motor power terminals (U/V/W). Doing so will fail the driver and servo motor.

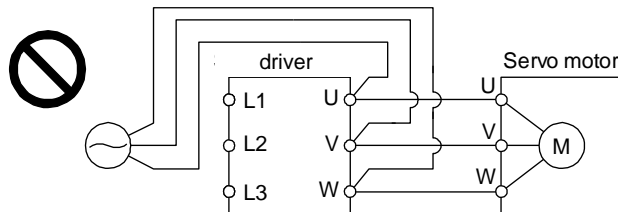

- 3) The grounding terminal of the servo motor is connected to the PE terminal of the driver.

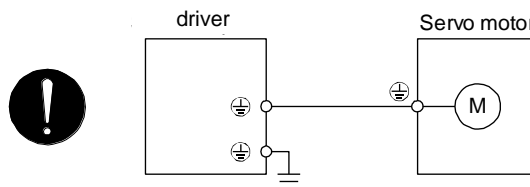

- 4) The CN2 connector of the driver should be connected to the encoder of the servo motor securely using the encoder cable.

4. STARTUP

(c) When you use an option and auxiliary equipment

1) LECSND□-T□

When you use a regenerative option

- The lead wire between P+ terminal and D terminal should not be connected.
- The regenerative option wire should be connected between P+ and C terminal.
- Twisted wires should be used. (Refer to section 11.2.4.)

(2) I/O signal wiring

(a) The I/O signals should be connected correctly.

Use DO forced output to forcibly turn on/off the pins of the CN3 connector. You can use the function to check the wiring. In this case, switch on the control circuit power supply only.

Refer to section 3.2 for details of I/O signal connection.

(b) 24 V DC or higher voltage is not applied to the pins of the CN3 connector.

(c) Plate and DOCOM of the CN3 connector is not shorted.

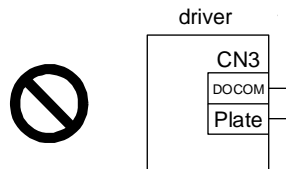

4.1.3 Surrounding environment

(1) Cable routing

(a) The wiring cables should not be stressed.

(b) The encoder cable should not be used in excess of its bending life. (Refer to section 10.4.)

(c) The connector of the servo motor should not be stressed.

(2) Environment

Signal cables and power cables are not shorted by wire offcuts, metallic dust or the like.

4.2 Startup

(1) Power on

When the main and control circuit power supplies are turned on, "b01" (for the first axis) appears on the driver display.

When the absolute position detection system is used in a rotary servo motor, first power-on results in [AL. 25 Absolute position erased] and the servo-on cannot be ready. The alarm can be deactivated by then switching power off once and on again.

Also, if power is switched on at the servo motor speed of 3000 r/min or higher, position mismatch may occur due to external force or the like. Power must therefore be switched on when the servo motor is at a stop.

(2) Parameter setting

Set the parameters according to the structure and specifications of the machine. Refer to chapter 5 for details.

After setting the above parameters, turn power off as necessary. Then switch power on again to enable the parameter values.

4. STARTUP

(3) Servo-on

Enable the servo-on with the following procedure.

- (a) Switch on main circuit power supply and control circuit power supply.
- (b) Transmit the servo-on command with the upper side.

When the servo-on status is enabled, the driver is ready to operate and the servo motor is locked.

(4) Home position return

Always perform home position return before starting positioning operation.

(5) Stop

Turn off the servo-on command after the servo motor has stopped, and then switch the power off.

If any of the following situations occurs, the driver suspends the running of the servo motor and brings it to a stop.

Refer to section 3.9 for the servo motor with a lock.

	Operation/command	Stopping condition
Upper side	Servo-off command	The base circuit is shut off and the servo motor coasts.
	Ready-off command	The base circuit is shut off and the dynamic brake operates to bring the servo motor to a stop.
	Quick stop command	The servo motor decelerates to a stop with the command.
Driver	Alarm occurrence	The servo motor decelerates to a stop with the command. With some alarms, however, the dynamic brake operates to bring the servo motor to a stop. (Refer to chapter 8.)
	EM2 (Forced stop 2) off	The servo motor decelerates to a stop with the command. [AL. E6 Servo forced stop warning] occurs. EM2 has the same function as EM1 in the torque mode. Refer to section 3.5 for EM1.
	STO (STO1, STO2) off	The base circuit is shut off and the dynamic brake operates to bring the servo motor to a stop.

4. STARTUP

4.3 Switch setting and display of the driver

POINT

- For EtherNet/IP and PROFINET, an IP address is displayed in the digit of the axis number.

Switching to the test operation mode and setting control axis No. are enabled with switches on the driver. On the driver display (three-digit, seven-segment LED), check the status of communication with the upper side at power-on, and the axis number, and diagnose a malfunction at occurrence of an alarm.

4.3.1 Switches

! WARNING

- When switching the axis selection rotary switch (SW2/SW3) and mode select switch (SW1), use insulated screw driver. Do not use a metal screw driver. Touching patterns on electronic boards, lead of electronic parts, etc. may cause an electric shock.

POINT

- Turning "ON (up)" all the mode select switches (SW1) enables an operation mode for manufacturer setting and displays "off". The mode is not available. Set the mode select switches (SW1) correctly according to this section.
- Cycling the main circuit power supply and control circuit power supply enables the setting of each switch.

The following explains the mode select switches (SW1) and the axis selection rotary switch.

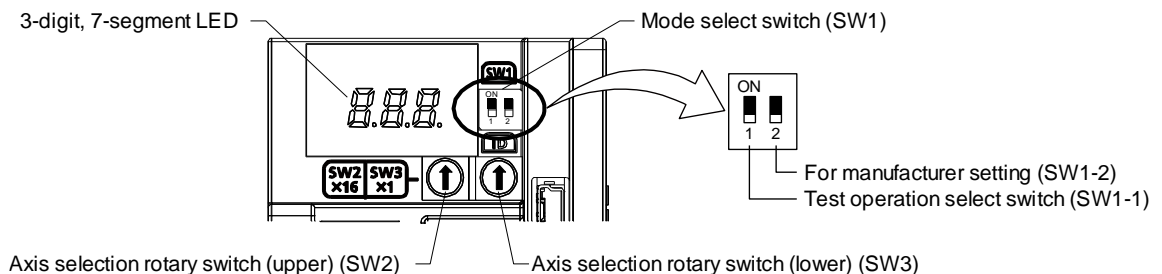

(1) Test operation select switch (SW1-1)

To use the test operation mode, turn "ON (up)" the switch. Turning "ON (up)" the switch enables the test operation mode. In the test operation mode, the functions such as JOG operation, positioning operation, and machine analyzer are available with Setup software (MR Configurator2™)

(2) Axis selection rotary switch (SW2/SW3)

Control axis No. of the servo can be set. For the settings, refer to chapter 18,19,20.

4. STARTUP

4.3.2 Scrolling display

Axis number will be displayed in hexadecimal. For 100h or more, last two digits will be displayed.

(1) Normal display

(a) For EtherCAT

When there is no alarm, the axis No. and blank are displayed in rotation.

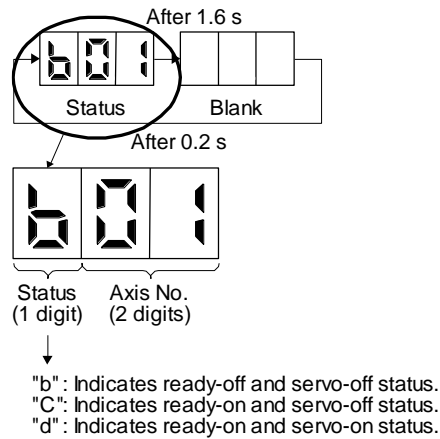

(b) For EtherNet/IP and PROFINET

When there is no alarm, the IP address is displayed.

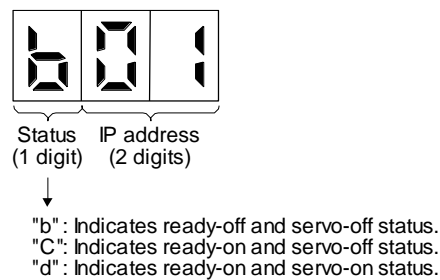

(2) Alarm display

When an alarm occurs, the alarm number (two digits) and the alarm detail (one digit) are displayed following the status display. For example, the following shows when [AL. 32 Overcurrent] is occurring.

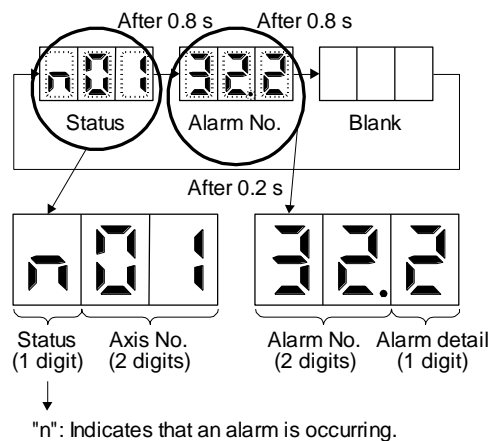

4. STARTUP

When an alarm occurs during the network initial communication, the alarm number (two digits), the alarm detail (one digit), and the network initial communication status are displayed following the status display. For example, the following shows when [AL. 16.1 Encoder initial communication - Receive data error 1] is occurring.

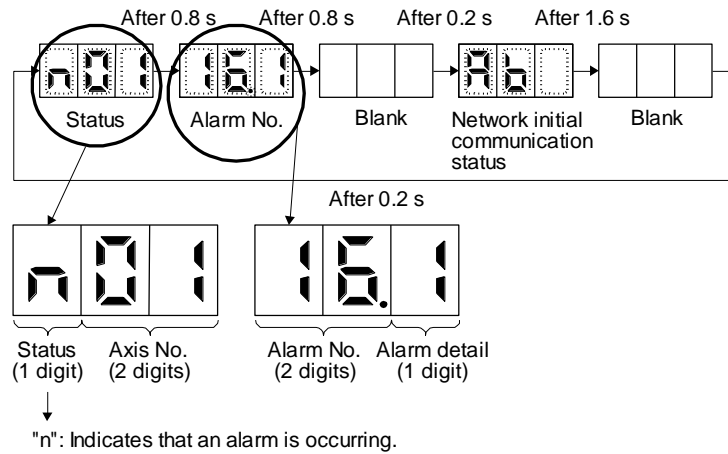

4. STARTUP

4.3.3 Status display of an axis

(1) Display sequence

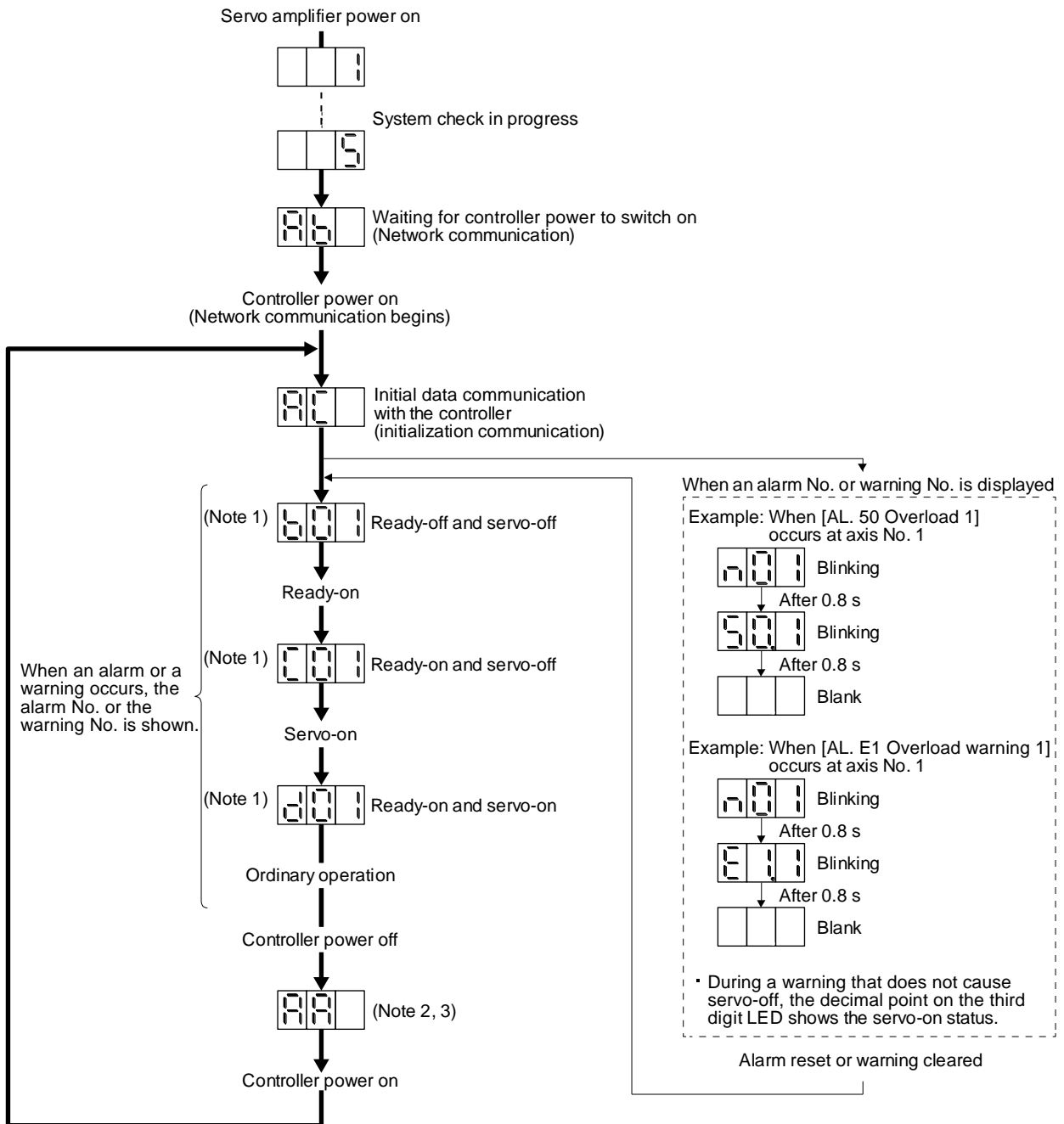









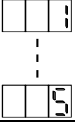



Note 1. ... The segment of the last 2 digits shows the axis number.
 Axis No. 1 Axis No. 2

2. For the EtherCAT, turning off the upper side power in the "Operational" state triggers [AL. 86.1 Network communication error 1].
3. For PROFINET, "Ab" is displayed.

4. STARTUP

(2) Indication list

Indication	Status	Description
	Initializing	System check in progress
	Initializing	No connection with the upper side
	Initializing	During initial communication with the upper side
	Initializing standby	Communication disconnection with the upper side
(Note 1) 	Ready-off	The ready-off signal from the upper side was received.
(Note 1) 	Servo-on	The ready-off signal from the upper side was received.
(Note 1) 	Servo-off	The ready-off signal from the upper side was received.
(Note 1) 	Alarm occurrence	An alarm or warning occurred on the driver.
(Note 2) 	Alarm and warning	The alarm No. and the warning No. that occurred is displayed. (Refer to chapter 8.)
	CPU error	CPU watchdog error has occurred.
(Note 1)   	(Note 3) Test operation mode	During test operation JOG operation, positioning operation, program operation, output signal (DO) forced output, motor-less operation, or single-step feed was set.

Note 1. ## is displayed in hexadecimal. The following table shows the description.

##	Description
00	For the last 2 digits of axis No. or automatic setting with the upper side.
01 }	Last 2 digits of axis No.
FF	

2. ** indicates the alarm No. and the warning No.
3. Requires the Setup software (MR Configurator2™)

4. STARTUP

4.4 Test operation

Before starting actual operation, perform test operation to make sure that the machine operates normally. Refer to section 4.2 for the power on and off methods of the driver.

POINT

- If necessary, verify upper side program by using motor-less operation. Refer to section 4.5.2 for the motor-less operation.
- When EtherNet/IP and PROFINET are used and the test operation mode is set, the value set with the axis selection rotary switch (SW2/SW3) is displayed in the digit of the axis number.

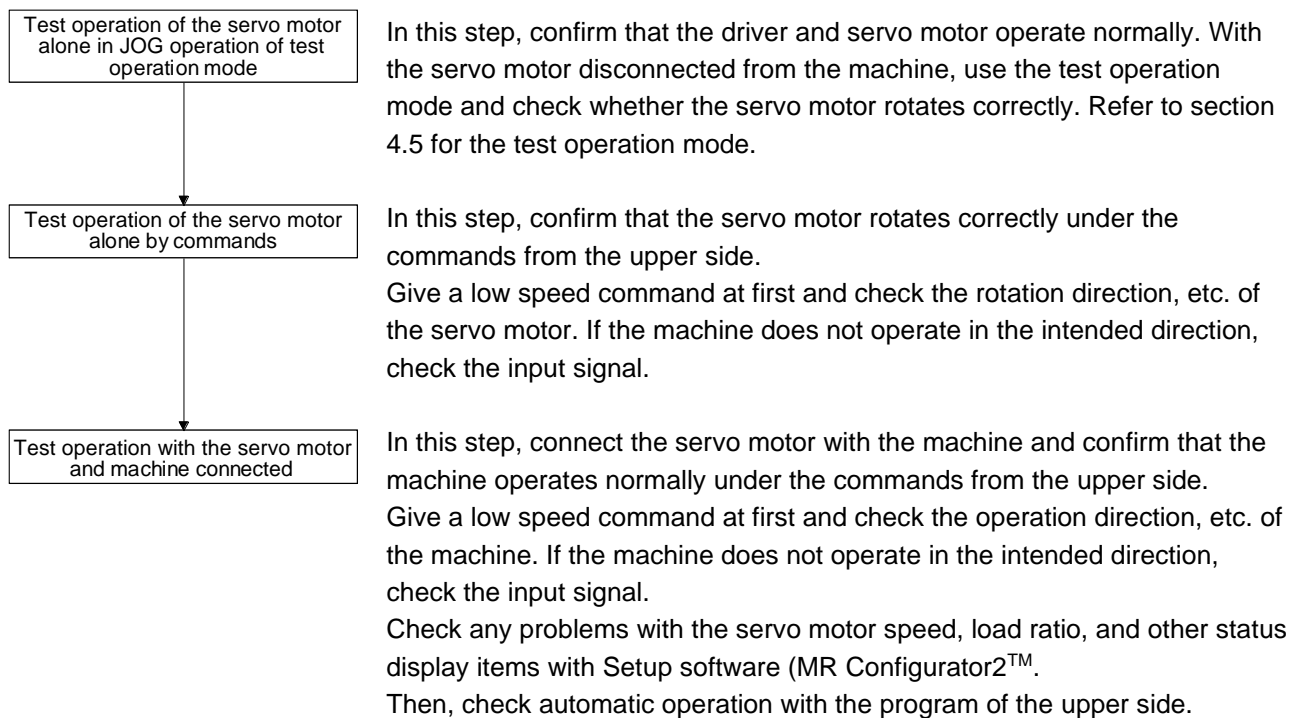

4.5 Test operation mode

CAUTION

- The test operation mode is designed for checking servo operation. It is not for checking machine operation. Do not use this mode with the machine. Always use the servo motor alone.
- If the servo motor operates abnormally, use EM2 (Forced stop 2) to stop it.

POINT

- The content described in this section indicates that the driver and a personal computer are directly connected.

By using a personal computer and Setup software (MR Configurator2™), you can execute JOG operation, positioning operation, output signal (DO) forced output, and program operation.

4. STARTUP

4.5.1 Test operation mode in Setup software (MR Configurator2™)

POINT
<ul style="list-style-type: none"> ● When the test operation mode is selected with the test operation select switch (SW1-1), the Network communication for the driver in the test operation mode and the following drivers is blocked. ● For the EtherCAT, turning on the test operation select switch (SW1-1) with the following parameter settings triggers [AL. 37 Parameter error]. <ul style="list-style-type: none"> ▪ "Automatic selection by each network (_ _ _ 0) (initial value)" of "Control mode selection" is selected in [Pr. PA01].

(1) Test operation mode

(a) Jog operation

Jog operation can be performed without using the upper side. Use this operation with the forced stop reset. This operation may be used independently of whether the servo is on or off and whether the upper side is connected or not.

Exercise control on the jog operation screen of Setup software (MR Configurator2™)

1) Operation pattern

Item	initial value	Setting range
Motor speed [r/min]	200	0 to max. speed
Acceleration/deceleration time constant [ms]	1000	0 to 50000

2) Operation method

a) When the check box of "Rotation only while the CCW or CW button is being pushed." is checked.

Operation	Screen control
Forward rotation start	Keep pressing "Forward".
Reverse rotation start	Keep pressing "Reverse".
Stop	Release "Forward" or "Reverse".
Forced stop	Click "Forced stop".

b) When the check box of "Rotation only while the CCW or CW button is being pushed." is not checked.

Operation	Screen control
Forward rotation start	Click "Forward".
Reverse rotation start	Click "Reverse".
Stop	Click "Stop".
Forced stop	Click "Forced stop".

4. STARTUP

(b) Positioning operation

Positioning operation can be performed without using the upper side. Use this operation with the forced stop reset. This operation may be used independently of whether the servo is on or off and whether the upper side is connected or not.

Exercise control on the positioning operation screen of Setup software (MR Configurator2™).

1) Operation pattern

Item	initial value	Setting range
Travel distance [pulse]	4000	0 to 99999999
Motor speed [r/min]	200	0 to max. speed
Acceleration/deceleration time constant [ms]	1000	0 to 50000
Repeat pattern	Fwd. rot. (CCW) to rev. rot. (CW)	Fwd. rot. (CCW) to rev. rot. (CW) Fwd. rot. (CCW) to fwd. rot. (CCW) Rev. rot. (CW) to fwd. rot. (CCW) Rev. rot. (CW) to rev. rot. (CW)
Dwell time [s]	2.0	0.1 to 50.0
Number of repeats [time]	1	1 to 9999

2) Operation method

Operation	Screen control
Forward rotation start	Click "Forward".
Reverse rotation start	Click "Reverse".
Pause	Click "Pause".
Stop	Click "Stop".
Forced stop	Click "Forced stop".

(c) Program operation

Positioning operation can be performed in two or more operation patterns combined, without using the upper side. Use this operation with the forced stop reset. This operation may be used independently of whether the servo is on or off and whether the upper side is connected or not.

Exercise control on the program operation screen of Setup software (MR Configurator2™) For details, refer to Help of Setup software (MR Configurator2™).

Operation	Screen control
Start	Click "Start".
Pause	Click "Pause".
Stop	Click "Stop".
Forced stop	Click "Forced stop".

(d) Output signal (DO) forced output

Output signals can be switched on/off forcibly independently of the servo status. Use this function for output signal wiring check, etc. Exercise control on the DO forced output screen of Setup software (MR Configurator2™).

4. STARTUP

(e) Single-step feed

The positioning operation can be performed in accordance with the point table No. set with Setup software (MR Configurator2™).

Select the test operation/single-step feed from the menu of Setup software (MR Configurator2™).

When the single-step feed window is displayed, input the following items and operate.

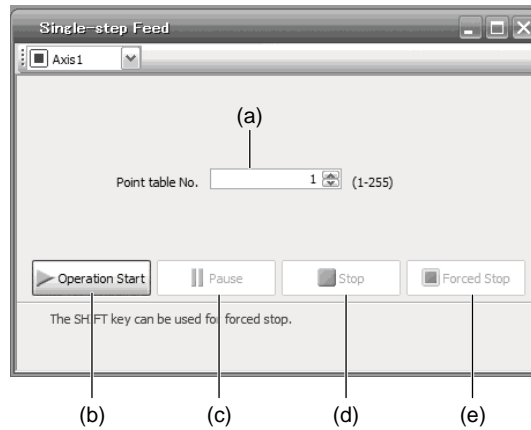

Point table operation

- 1) Set the point table No.
Enter a point table No. in the input box (a) "Point table No.".
- 2) Forward/reverse the servo motor
Click "Operation Start" (b) to rotate the servo motor.
- 3) Pause the servo motor
Click "Pause" (c) to temporarily stop the servo motor.
Click "Operation Start" (b) during a temporary stop to restart the rotation of the remaining travel distance.
In addition, click "Stop" (d) during a temporary stop to clear the remaining travel distance.
- 4) Stop the servo motor
Click "Stop" (d) to stop the servo motor. At this time, the remaining travel distance will be cleared.
Click "Operation Start" (b) to restart the rotation.
- 5) Execute the servo motor forced stop
Click "Forced Stop" (e) to make an instantaneous stop. When "Forced Stop" is enabled, "Operation Start" cannot be used. Click "Forced Stop" again to enable "Operation Start".
- 6) Switch to the normal operation mode
Before switching from the test operation mode to the normal operation mode, turn off the driver.

4. STARTUP

(2) Operation procedure

- 1) Turn off the power.
- 2) Turn "ON (up)" SW1-1.

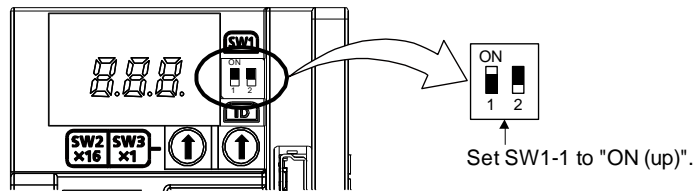

Turning "ON (up)" SW1-1 during power-on will not start the test operation mode.

3) Turn on the driver.

When initialization is completed, the decimal point on the first digit will blink.

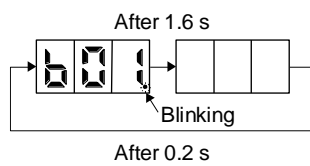

When an alarm or warning also occurs during the test operation, the decimal point on the first digit will blink as follows.

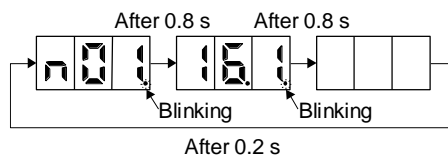

4) Start operation with the personal computer.

4. STARTUP

4.5.2 Motor-less operation in upper side

POINT
● Connect the upper side to the driver before the motor-less operation.

(1) Motor-less operation

Without connecting the servo motor to the driver, output signals or status displays can be provided in response to the upper side commands as if the servo motor is actually running. This operation may be used to check the upper side sequence. Use this operation with the forced stop reset. Use this operation with the driver connected to the upper side.

To stop the motor-less operation, set "Disabled (_ _ _ 0)" of "Motor-less operation selection" in [Pr. PC05]. The motor-less operation will be disabled from the next power-on.

(a) Load conditions

Load item	Condition
Load torque	0
Load to motor inertia ratio	[Pr. PB06 Load to motor inertia ratio/load to motor mass ratio]

(b) Alarms

The following alarms and warning do not occur. However, the other alarms and warnings occur as when the servo motor is connected.

- [AL. 16 Encoder initial communication error 1]
- [AL. 1E Encoder initial communication error 2]
- [AL. 1F Encoder initial communication error 3]
- [AL. 20 Encoder normal communication error 1]
- [AL. 21 Encoder normal communication error 2]
- [AL. 25 Absolute position erased]
- [AL. 92 Battery cable disconnection warning]
- [AL. 9F Battery warning]

(2) Operation procedure

- 1) Set the driver to the servo-off status.
- 2) Set [Pr. PC05] to " _ _ _ 1", turn "OFF (down)" the test operation mode switch (SW1-1), and then turn on the power supply.

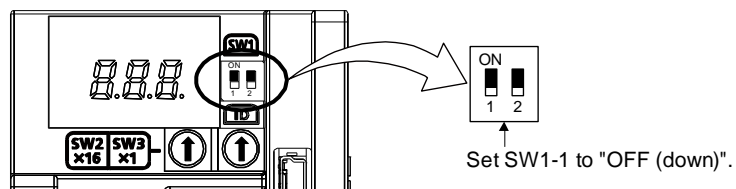

- 3) Start the motor-less operation with the upper side.

The display shows the following screen.

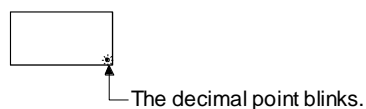

5. PARAMETERS

5. PARAMETERS.....	2
5.1 Parameter list.....	2
5.1.1 Basic setting parameters ([Pr. PA_ _]).....	3
5.1.2 Gain/filter setting parameters ([Pr. PB_ _]).....	4
5.1.3 Extension setting parameters ([Pr. PC_ _]).....	6
5.1.4 I/O setting parameters ([Pr. PD_ _]).....	8
5.1.5 I/O Extension setting 2 parameters ([Pr. PE_ _]).....	9
5.1.6 Extension setting 3 parameters ([Pr. PF_ _]).....	11
5.1.7 Positioning control parameters ([Pr. PT_ _]).....	13
5.1.8 Network setting parameters ([Pr. PN_ _]).....	16
5.2 Detailed list of parameters.....	17
5.2.1 Basic setting parameters ([Pr. PA_ _]).....	17
5.2.2 Gain/filter setting parameters ([Pr. PB_ _]).....	31
5.2.3 Extension setting parameters ([Pr. PC_ _]).....	44
5.2.4 I/O setting parameters ([Pr. PD_ _]).....	64
5.2.5 Extension setting 2 parameters ([Pr. PE_ _]).....	68
5.2.6 Extension setting 3 parameters ([Pr. PF_ _]).....	72
5.2.7 Positioning control parameters ([Pr. PT_ _]).....	74
5.2.8 Network setting parameters ([Pr. PN_ _]).....	99
5.3 Software limit.....	99
5.4 How to set the electronic gear.....	100
5.4.1 Electronic gear setting in the cyclic synchronous mode, profile mode and point table method.....	100
5.4.2 Electronic gear setting in the indexer method.....	102

5. PARAMETERS

5. PARAMETERS

CAUTION

- Never make a drastic adjustment or change to the parameter values as doing so will make the operation unstable.
- Do not change the parameter settings as described below. Doing so may cause an unexpected condition, such as failing to start up the driver.
 - Changing the values of the parameters for manufacturer setting
 - Setting a value out of the range
 - Changing the fixed values in the digits of a parameter
- When you write parameters with the upper side, make sure that the control axis No. of the driver is set correctly. Otherwise, the parameter settings of another axis may be written, possibly causing the driver to be an unexpected condition.

POINT

- The fractional portion of the value in each of the following parameters will be rounded down.
 - [Pr. PT05 Home position return speed]
 - [Pr. PT06 Creep speed]
 - [Pr. PT65 Profile speed command]

5.1 Parameter list

POINT

- The parameter whose symbol is preceded by * is enabled with the following conditions:
 - *: After setting the parameter, cycle the power or reset the network communication.
 - ** : After setting the parameter, cycle the power.

5. PARAMETERS

5.1.1 Basic setting parameters ([Pr. PA_ _])

No.	Symbol	Name	Initial value	Unit	Operation mode
					Standard
PA01	**STY	Operation mode	1000h		○
PA02	**REG	Regenerative option	0000h		○
PA03	*ABS	Absolute position detection system	0000h		○
PA04	*AOP1	Function selection A-1	2000h		○
PA05		For manufacturer setting	10000		
PA06	*CMX	Electronic gear numerator/Number of gear teeth on machine side	1		○
PA07	*CDV	Electronic gear denominator/Number of gear teeth on servo motor side	1		○
PA08	ATU	Auto tuning mode	0001h		○
PA09	RSP	Auto tuning response	16		○
PA10	INP	In-position range	1600	[pulse]	○
PA11	TLP	Forward rotation torque limit/	1000.0	[%]	○
PA12	TLN	Reverse rotation torque limit/	1000.0	[%]	○
PA13		For manufacturer setting	0000h		
PA14	*POL	Rotation direction selection/	0		○
PA15	*ENR	Encoder output pulses	4000	[pulse/rev]	○
PA16	*ENR2	Encoder output pulses 2	1		○
PA17	**MSR	Servo motor series setting	0000h		
PA18	**MTY	Servo motor type setting	0000h		
PA19	*BLK	Parameter writing inhibit	00ABh		○
PA20	*TDS	Tough drive setting	0000h		○
PA21	*AOP3	Function selection A-3	0001h		○
PA22	**PCS	Position control composition selection	0000h		○
PA23	DRAT	Drive recorder arbitrary alarm trigger setting	0000h		○
PA24	AOP4	Function selection A-4	0000h		○
PA25	OTHOV	One-touch tuning - Overshoot permissible level	0	[%]	○
PA26	*AOP5	Function selection A-5	0000h		○
PA27		For manufacturer setting	0000h		
PA28			0000h		
PA29			0000h		
PA30			0000h		
PA31			0000h		
PA32			0000h		

5. PARAMETERS

5.1.2 Gain/filter setting parameters ([Pr. PB_ _])

No.	Symbol	Name	Initial value	Unit	Operation mode
					Standard
PB01	FILT	Adaptive tuning mode (adaptive filter II)	0000h		○
PB02	VRFT	Vibration suppression control tuning mode (advanced vibration suppression control II)	0000h		○
PB03		For manufacturer setting	18000		
PB04	FFC	Feed forward gain	0	[%]	○
PB05		For manufacturer setting	500		
PB06	GD2	Load to motor inertia ratio/	7.00	[Multiplier]	○
PB07	PG1	Model loop gain	15.0	[rad/s]	○
PB08	PG2	Position loop gain	37.0	[rad/s]	○
PB09	VG2	Speed loop gain	823	[rad/s]	○
PB10	VIC	Speed integral compensation	33.7	[ms]	○
PB11	VDC	Speed differential compensation	980		○
PB12	OVA	Overshoot amount compensation	0	[%]	○
PB13	NH1	Machine resonance suppression filter 1	4500	[Hz]	○
PB14	NHQ1	Notch shape selection 1	0000h		○
PB15	NH2	Machine resonance suppression filter 2	4500	[Hz]	○
PB16	NHQ2	Notch shape selection 2	0000h		○
PB17	NHF	Shaft resonance suppression filter	0000h		○
PB18	LPF	Low-pass filter setting	3141	[rad/s]	○
PB19	VRF11	Vibration suppression control 1 - Vibration frequency	100.0	[Hz]	○
PB20	VRF12	Vibration suppression control 1 - Resonance frequency	100.0	[Hz]	○
PB21	VRF13	Vibration suppression control 1 - Vibration frequency damping	0.00		○
PB22	VRF14	Vibration suppression control 1 - Resonance frequency damping	0.00		○
PB23	VFBF	Low-pass filter selection	0000h		○
PB24	*MVS	Slight vibration suppression control	0000h		○
PB25	*BOP1	Function selection B-1	0000h		○
PB26	*CDP	Gain switching function	0000h		○
PB27	CDL	Gain switching condition	10	[kpulse/s]/ [pulse]/ [r/min]	○
PB28	CDT	Gain switching time constant	1	[ms]	○
PB29	GD2B	Load to motor inertia ratio/	7.00	[Multiplier]	○
PB30	PG2B	Position loop gain after gain switching	0.0	[rad/s]	○
PB31	VG2B	Speed loop gain after gain switching	0	[rad/s]	○
PB32	VICB	Speed integral compensation after gain switching	0.0	[ms]	○
PB33	VRF11B	Vibration suppression control 1 - Vibration frequency after gain switching	0.0	[Hz]	○
PB34	VRF12B	Vibration suppression control 1 - Resonance frequency after gain switching	0.0	[Hz]	○
PB35	VRF13B	Vibration suppression control 1 - Vibration frequency damping after gain switching	0.00		○
PB36	VRF14B	Vibration suppression control 1 - Resonance frequency damping after gain switching	0.00		○
PB37		For manufacturer setting	1600		
PB38			0.00		
PB39			0.00		
PB40			0.00		
PB41			0000h		
PB42			0000h		
PB43			0000h		
PB44			0.00		
PB45	CNHF	Command notch filter	0000h		○

5. PARAMETERS

No.	Symbol	Name	Initial value	Unit	Operation mode
					Standard
PB46	NH3	Machine resonance suppression filter 3	4500	[Hz]	<input type="radio"/>
PB47	NHQ3	Notch shape selection 3	0000h		<input type="radio"/>
PB48	NH4	Machine resonance suppression filter 4	4500	[Hz]	<input type="radio"/>
PB49	NHQ4	Notch shape selection 4	0000h		<input type="radio"/>
PB50	NH5	Machine resonance suppression filter 5	4500	[Hz]	<input type="radio"/>
PB51	NHQ5	Notch shape selection 5	0000h		<input type="radio"/>
PB52	VRF21	Vibration suppression control 2 - Vibration frequency	100.0	[Hz]	<input type="radio"/>
PB53	VRF22	Vibration suppression control 2 - Resonance frequency	100.0	[Hz]	<input type="radio"/>
PB54	VRF23	Vibration suppression control 2 - Vibration frequency damping	0.00		<input type="radio"/>
PB55	VRF24	Vibration suppression control 2 - Resonance frequency damping	0.00		<input type="radio"/>
PB56	VRF21B	Vibration suppression control 2 - Vibration frequency after gain switching	0.0	[Hz]	<input type="radio"/>
PB57	VRF22B	Vibration suppression control 2 - Resonance frequency after gain switching	0.0	[Hz]	<input type="radio"/>
PB58	VRF23B	Vibration suppression control 2 - Vibration frequency damping after gain switching	0.00		<input type="radio"/>
PB59	VRF24B	Vibration suppression control 2 - Resonance frequency damping after gain switching	0.00		<input type="radio"/>
PB60	PG1B	Model loop gain after gain switching	0.0	[rad/s]	<input type="radio"/>
PB61		For manufacturer setting	0.0		
PB62			0000h		
PB63			0000h		
PB64			0000h		

5. PARAMETERS

5.1.3 Extension setting parameters ([Pr. PC_ _])

No.	Symbol	Name	Initial value	Unit	Operation mode
					Standard
PC01	ERZ	Error excessive alarm level	0	[rev]	○
PC02	MBR	Electromagnetic brake sequence output	0	[ms]	○
PC03	*ENRS	Encoder output pulse selection	0000h		○
PC04	**COP1	Function selection C-1	0000h		○
PC05	**COP2	Function selection C-2	0000h		○
PC06	*COP3	Function selection C-3	0000h		○
PC07	ZSP	Zero speed	50	[r/min]	○
PC08	OSL	Overspeed alarm detection level	0	[r/min]	○
PC09	MOD1	Analog monitor 1 output	0000h		○
PC10	MOD2	Analog monitor 2 output	0001h		○
PC11	MO1	Analog monitor 1 offset	0	[mV]	○
PC12	MO2	Analog monitor 2 offset	0	[mV]	○
PC13		For manufacturer setting	0		
PC14			0		
PC15			0		
PC16			0000h		
PC17	**COP4	Function selection C-4	0000h		○
PC18	*COP5	Function selection C-5	0010h		○
PC19	*COP6	Function selection C-6	0000h		○
PC20	*COP7	Function selection C-7	0000h		○
PC21	*BPS	Alarm history clear	0000h		○
PC22		For manufacturer setting	0		
PC23			0000h		
PC24	RSBR	Forced stop deceleration time constant	100	[ms]	○
PC25		For manufacturer setting	0		
PC26	**COP8	Function selection C-8	0000h		○
PC27	**COP9	Function selection C-9	0000h		○
PC28		For manufacturer setting	0000h		
PC29	*COPB	Function selection C-B	1000h		○
PC30		For manufacturer setting	0		
PC31	RSUP1	Vertical axis freefall prevention compensation amount	0	[0.0001 rev]	○
PC32		For manufacturer setting	0000h		
PC33			0		
PC34			100		
PC35			0000h		
PC36			0000h		
PC37			0000h		
PC38	ERW	Error excessive warning level	0	[rev]	○
PC39		For manufacturer setting	0000h		
PC40			0000h		
PC41			0000h		
PC42			0000h		
PC43			0000h		
PC44			0000h		
PC45			0000h		

5. PARAMETERS

No.	Symbol	Name	Initial value	Unit	Operation mode
					Standard
PC46		For manufacturer setting	0000h		
PC47			0000h		
PC48			0000h		
PC49			0000h		
PC50			0000h		
PC51			0000h		
PC52			0000h		
PC53			0000h		
PC54			0000h		
PC55			0000h		
PC56			0000h		
PC57			0000h		
PC58			0000h		
PC59			0000h		
PC60			0000h		
PC61			0000h		
PC62			0000h		
PC63		0000h			
PC64		0000h			
PC65	ZSP2L	Zero speed 2 level	50.00	[r/min]	○
PC66	ZSP2F	Zero speed 2 filtering time	10	[ms]	○
PC67	FEWL	Following error output level	0000h	10 ^{STM} [μm]/ 10 ^(STM-4) [inch]/ 10 ⁻³ [degree]/ [pulse]	○
PC68	FEWH		00C0h		
PC69	FEWF	Following error output filtering time	10	[ms]	○
PC70	INP2R	In-position 2 output range	100	10 ^{STM} [μm]/ 10 ^(STM-4) [inch]/ 10 ⁻³ [degree]/ [pulse]	○
PC71	INP2F	In-position 2 output filtering time	10	[ms]	○
PC72	SA2R	Speed reached 2 output range	20.00	[r/min]	○
PC73	SA2F	Speed reached 2 output filtering time	10	[ms]	○
PC74		For manufacturer setting	10.0		
PC75			10		
PC76	*COPE	Function selection C-E	0001h		○
PC77		For manufacturer setting	0000h		
PC78			0000h		
PC79	*COP10	Function selection C-10	0000h		○
PC80		For manufacturer setting	0000h		

5. PARAMETERS

5.1.4 I/O setting parameters ([Pr. PD_ _])

No.	Symbol	Name	Initial value	Unit	Operation mode
					Standard
PD01	*DIA1	Input signal automatic on selection 1	0000h		<input type="radio"/>
PD02		For manufacturer setting	0000h		
PD03	*DI1	Input device selection 1	000Ah		<input type="radio"/>
PD04	*DI2	Input device selection 2	000Bh		<input type="radio"/>
PD05	*DI3	Input device selection 3	0022h		<input type="radio"/>
PD06		For manufacturer setting	0000h		
PD07	*DO1	Output device selection 1	0005h		<input type="radio"/>
PD08	*DO2	Output device selection 2	0004h		<input type="radio"/>
PD09	*DO3	Output device selection 3	0003h		<input type="radio"/>
PD10		For manufacturer setting	0000h		
PD11	*DIF	Input filter setting	0004h		<input type="radio"/>
PD12	*DOP1	Function selection D-1	0101h		<input type="radio"/>
PD13	*DOP2	Function selection D-2	0000h		<input type="radio"/>
PD14	*DOP3	Function selection D-3	0000h		<input type="radio"/>
PD15		For manufacturer setting	0000h		
PD16			0000h		
PD17			0000h		
PD18			0000h		
PD19			0000h		
PD20			0		
PD21			0		
PD22			0		
PD23			0		
PD24			0000h		
PD25			0000h		
PD26			0000h		
PD27		0000h			
PD28		0000h			
PD29		0000h			
PD30		0			
PD31		0			
PD32		0			
PD33		0000h			
PD34		0000h			
PD35		0000h			
PD36		0000h			
PD37	*TPOP	Touch probe function selection	0000h		<input type="radio"/>
PD38	*TPR1	Touch probe selection 1	002Ch		<input type="radio"/>
PD39		For manufacturer setting	002Dh		
PD40			0		
PD41			0000h		
PD42			0000h		
PD43			0000h		
PD44			0000h		
PD45			0000h		
PD46			0000h		
PD47			0000h		
PD48			0000h		

5. PARAMETERS

5.1.5 I/O Extension setting 2 parameters ([Pr. PE_ _])

No.	Symbol	Name	Initial value	Unit	Operation mode
					Standard
PE01	**FCT1	Fully closed loop function selection 1 Do not change this value.	0000h		
PE02		For manufacturer setting	0000h		
PE03	*FCT2	Fully closed loop function selection 2 Do not change this value.	0003h		
PE04	**FBN	Fully closed loop control - Feedback pulse electronic gear 1 – Numerator Do not change this value.	1		
PE05	**FBD	Fully closed loop control - Feedback pulse electronic gear 1 – Denominator Do not change this value.	1		
PE06	BC1	Fully closed loop control - Speed deviation error detection level Do not change this value.	400	[r/min]	
PE07	BC2	Fully closed loop control - Position deviation error detection level Do not change this value.	100	[kpulse]	
PE08	DUF	Fully closed loop dual feedback filter Do not change this value.	10	[rad/s]	
PE09		For manufacturer setting	0000h		
PE10	FCT3	Fully closed loop function selection 3 Do not change this value.	0000h		
PE11		For manufacturer setting	0000h		
PE12			0000h		
PE13			0000h		
PE14			0111h		
PE15			20		
PE16			0000h		
PE17			0000h		
PE18			0000h		
PE19			0000h		
PE20			0000h		
PE21			0000h		
PE22			0000h		
PE23			0000h		
PE24			0000h		
PE25		0000h			
PE26		0000h			
PE27		0000h			
PE28		0000h			
PE29		0000h			
PE30		0000h			
PE31		0000h			
PE32		0000h			
PE33		0000h			
PE34	**FBN2	Fully closed loop control - Feedback pulse electronic gear 2 – Numerator Do not change this value.	1		
PE35	**FBD2	Fully closed loop control - Feedback pulse electronic gear 2 – Denominator Do not change this value.	1		
PE36		For manufacturer setting	0.0		
PE37			0.00		
PE38			0.00		
PE39			20		
PE40			0000h		
PE41	EOP3	Function selection E-3	0000h		○
PE42		For manufacturer setting	0		
PE43			0.0		
PE44	LMCP	Lost motion compensation positive-side compensation value selection	0	[0.01%]	○
PE45	LMCN	Lost motion compensation negative-side compensation value selection	0	[0.01%]	○
PE46	LMFLT	Lost motion filter setting	0	[0.1 ms]	○
PE47	TOF	Torque offset	0	[0.01%]	○

5. PARAMETERS

PE48	*LMOP	Lost motion compensation function selection	0000h		<input type="radio"/>
PE49	LMCD	Lost motion compensation timing	0	[0.1 ms]	<input type="radio"/>
PE50	LMCT	Lost motion compensation non-sensitive band	0	[pulse]/ [kpulse]	<input type="radio"/>

No.	Symbol	Name	Initial value	Unit	Operation mode
					Standard
PE51		For manufacturer setting	0000h		
PE52			0000h		
PE53			0000h		
PE54			0000h		
PE55			0000h		
PE56			0000h		
PE57			0000h		
PE58			0000h		
PE59			0000h		
PE60			0000h		
PE61			0.00		
PE62			0.00		
PE63			0.00		
PE64			0.00		

5. PARAMETERS

5.1.6 Extension setting 3 parameters ([Pr. PF_ _])

No.	Symbol	Name	Initial value	Unit	Operation mode
					Standard
PF01		For manufacturer setting	0000h		
PF02			0000h		
PF03			0000h		
PF04			0		
PF05			0000h		
PF06	*FOP5	Function selection F-5	0000h		○
PF07		For manufacturer setting	0000h		
PF08			0000h		
PF09			0		
PF10			0		
PF11			0		
PF12	DBT	Electronic dynamic brake operating time	2000	[ms]	○
PF13		For manufacturer setting	0000h		
PF14			10		
PF15			0000h		
PF16			0000h		
PF17			0000h		
PF18	**STOD	STO diagnosis error detection time	10	[s]	○
PF19		For manufacturer setting	0000h		
PF20			0000h		
PF21	DRT	Drive recorder switching time setting	0	[s]	○
PF22		For manufacturer setting	200		
PF23	OSCL1	Vibration tough drive - Oscillation detection level	50	[%]	○
PF24	*OSCL2	Vibration tough drive function selection	0000h		○
PF25	CVAT	SEMI-F47 function - Instantaneous power failure detection time	200	[ms]	○
PF26		For manufacturer setting	0		
PF27			0		
PF28			0		
PF29			0000h		
PF30			0		
PF31	FRIC	Machine diagnosis function - Friction judgment speed	0	[r/min]	○
PF32		For manufacturer setting	50		
PF33			0000h		
PF34			0000h		
PF35			0000h		
PF36			0000h		
PF37			0000h		
PF38			0000h		
PF39			0000h		
PF40			0000h		
PF41			0000h		
PF42			0000h		
PF43			0000h		
PF44			0		
PF45			0000h		
PF46			0000h		
PF47			0000h		
PF48			0000h		
PF49			100		
PF50			100		

5. PARAMETERS

No.	Symbol	Name	Initial value	Unit	Operation mode
					Standard
PF51		For manufacturer setting	0000h		
PF52			0000h		
PF53			0		
PF54			0		
PF55			0		
PF56			0		
PF57			0000h		
PF58			0000h		
PF59			0000h		
PF60			0000h		
PF61			0000h		
PF62			0000h		
PF63			0000h		
PF64			0000h		

5. PARAMETERS

5.1.7 Positioning control parameters ([Pr. PT_ _])

No.	Symbol	Name	Initial value	Unit	Operation mode
					Standard
PT01	**CTY	Command mode selection	0300h		○
PT02		For manufacturer setting	0001h		
PT03	*FTY	Feeding function selection	0000h		○
PT04		For manufacturer setting	0000h		
PT05	ZRF	Home position return speed	100.00	[r/min]	○
PT06	CRF	Creep speed	10.00	[r/min]	○
PT07	ZST	Home position shift distance	0	[μm]/ 10 ⁻⁴ [inch]/ 10 ⁻³ [degree]/ [pulse]	○
PT08		For manufacturer setting	0		
PT09	DCT	Travel distance after proximity dog	0	10 ^{STM} [μm]/ 10 ^(STM-4) [inch]/ 10 ⁻³ [degree]/ [pulse]	○
PT10	ZTM	Stopper type home position return stopper time	100	[ms]	○
PT11	ZTT	Stopper type home position return torque limit value	15.0	[%]	○
PT12	CRP	Rough match output range	0	10 ^{STM} [μm]/ 10 ^(STM-4) [inch]/ 10 ⁻³ [degree]/ [pulse]	○
PT13		For manufacturer setting	100		
PT14			0		
PT15	LMPL	Software limit +	0000h	10 ^{STM} [μm]/ 10 ^(STM-4) [inch]/ 10 ⁻³ [degree]/ [pulse]	○
PT16	LMPH		0000h		
PT17	LMNL	Software limit -	0000h	10 ^{STM} [μm]/ 10 ^(STM-4) [inch]/ 10 ⁻³ [degree]/ [pulse]	○
PT18	LMNH		0000h		
PT19	*LPPL	Position range output address +	0000h	10 ^{STM} [μm]/ 10 ^(STM-4) [inch]/ 10 ⁻³ [degree]/ [pulse]	○
PT20	*LPPH		0000h		

5. PARAMETERS

No.	Symbol	Name	Initial value	Unit	Operation mode
					Standard
PT21	*LNPL	Position range output address -	0000h	10 ^{STM} [μm]/ 10 ^(STM-4) [inch]/ 10 ⁻³ [degree]/ [pulse]	○
PT22	*LNPH		0000h		
PT23		For manufacturer setting	0		
PT24			0		
PT25			0		
PT26	*TOP2	Function selection T-2	0000h		○
PT27	*ODM	Indexer method - Operation mode selection	0000h		○
PT28	*STN	Number of stations per rotation	8	[stations]	○
PT29	*TOP3	Function selection T-3	0000h		○
PT30		For manufacturer setting	0000h		
PT31			0000h		
PT32			0000h		
PT33			0000h		
PT34	**PDEF	Point table default	0000h		○
PT35	*TOP5	Function selection T-5	0000h		○
PT36		For manufacturer setting	0000h		
PT37			10		
PT38			0000h		
PT39	INT	Torque limit delay time	100	[ms]	○
PT40	*SZS	Station home position shift distance	0	[pulse]	○
PT41	ORP	Home position return inhibit function selection	0000h		○
PT42		For manufacturer setting	0		
PT43			0		
PT44			0000h		
PT45	HMM	Home position return method	37		○
PT46	ESTC	Synchronous encoder filter time constant	0	[ms]	○
PT47		For manufacturer setting	0000h		
PT48			0000h		
PT49	STA	Acceleration time constant	0	[ms]	○
PT50	STB	Deceleration time constant	0	[ms]	○
PT51	STC	S-pattern acceleration/deceleration time constant	0	[ms]	○
PT52		For manufacturer setting	0		
PT53	TQS	Torque slope	0.0	[%/s]	○
PT54		For manufacturer setting	0		
PT55	*TOP8	Function selection T-8	0000h		○
PT56	HMA	Home position return acceleration time constant	0	[ms]	○
PT57	HMB	Home position return deceleration time constant	0	[ms]	○
PT58		For manufacturer setting	100.00		
PT59			500.00		
PT60			1000.00		
PT61			200.00		
PT62			0000h		
PT63			0000h		
PT64			0000h		
PT65	PVC	Profile speed command	100.00	[r/min]	○
PT66	MPVC	Maximum profile speed	20000.00	[r/min]	○
PT67	VLMT	Speed limit	500.00	[r/min]	○

5. PARAMETERS

No.	Symbol	Name	Initial value	Unit	Operation mode
					Standard
PT68		For manufacturer setting	0102h		
PT69	ZSTH	Home position shift distance (extension parameter)	0	[μm]/ 10 ⁻⁴ [inch]/ 10 ⁻³ [degree]/ [pulse]	○
PT70		For manufacturer setting	0000h		
PT71	DCTH	Travel distance after proximity dog (extension parameter)	0	10 ^{STM} [μm]/ 10 ^(STM-4) [inch]/ 10 ⁻³ [degree]/ [pulse]	○
PT72	ECMXL	Synchronous encoder electronic gear - Numerator	0000h		○
PT73	ECMXH		0000h		
PT74	ECDVL	Synchronous encoder electronic gear - Denominator	0000h		○
PT75	ECDVH		0000h		
PT76		For manufacturer setting	0000h		
PT77			0000h		
PT78			0000h		
PT79			0000h		
PT80			0000h		
			0000h		

5. PARAMETERS

5.1.8 Network setting parameters ([Pr. PN_ _])

No.	Symbol	Name	Initial value	Unit	Operation mode
					Standard
PN01	**NADR	Node address setting	0000h		○
PN02	CERT	Sync Error Counter Limit setting	0	(Note)	○
PN03		For manufacturer setting	0000h		
PN04			0000h		
PN05			0000h		
PN06	*NOP1	Function selection N-1	0000h		○
PN07		For manufacturer setting	0000h		
PN08			0000h		
PN09			0000h		
PN10			0000h		
PN11			0000h		
PN12			0000h		
PN13			0000h		
PN14			0000h		
PN15			0000h		
PN16			0000h		
PN17			0000h		
PN18			0000h		
PN19			0000h		
PN20			0000h		
PN21			0000h		
PN22			0000h		
PN23			0000h		
PN24			0000h		
PN25			0000h		
PN26			0000h		
PN27			0000h		
PN28			0000h		
PN29			0000h		
PN30			0000h		
PN31			0000h		
PN32			0000h		

Note. Refer to the function column of [Pr. PN02] for details.

5. PARAMETERS

5.2 Detailed list of parameters

POINT
<ul style="list-style-type: none"> ● Set a value to each "x" in the "Setting digit" columns. ● Symbols in the network column indicate the following networks. ECT: EtherCAT EIP: EtherNet/IP PNT: PROFINET

5.2.1 Basic setting parameters ([Pr. PA__])

No./ symbol/name	Setting digit	Function	Initial value [unit]	Network		
				ECT	EIP	PNT
PA01 **STY Operation mode	___x	Control mode selection Select a control mode. 0: Automatic selection by each network It will be "Profile mode" during test operation or when the network card is not connected. 1: Cyclic synchronous mode 2: Profile mode 6: Positioning mode (point table method) 8: Positioning mode (indexer method) Setting any value other than above will trigger [AL. 37 Parameter error]. Setting "1" when an incompatible network card is connected will trigger [AL. 37 Parameter error]. With EtherNet/IP, setting "6" or "8" will trigger [AL. 37 Parameter error]. Refer to table 5.1 for details of control modes in respective networks.	0h	○	○	○
	__x_	Do not change this value.	0h	○	○	○
	_x__	For manufacturer setting	0h	/	/	/
	x___		1h	/	/	/

Table 5.1 Control mode selection

[Pr. PA01] setting	Control mode		
	EtherCAT	EtherNet/IP	PROFINET
___0	Cyclic synchronous mode (csp/csv/cst) Homing mode (hm)	Profile mode (pp/pv/tq)/homing mode (hm) (*1)	
___1	Cyclic synchronous mode (csp/csv/cst) Homing mode (hm)	/	/
___2	Profile mode (pp/pv/tq)/homing mode (hm) (*1)		
___6	Point table mode (pt)/Jog mode (jg)/homing mode (hm)	/	Point table mode (pt)/Jog mode (jg)/homing mode (hm)
___8	Indexer mode (idx)/Jog mode (jg)/homing mode (hm)	/	Indexer mode (idx)/Jog mode (jg)/homing mode (hm)

(*1) When using EtherNet/IP or PROFINET, the PA01 setting values "___0" and "___2" have the same function. Use the setting value "___0" (default value).

(Note) In servo motor speed commands, when the mode is other than csv mode, the decimal places of the actual motor drive speed are rounded down.

5. PARAMETERS

No./ symbol/name	Setting digit	Function	Initial value [unit]	Network		
				ECT	EIP	PNT
PA02 **REG Regenerative option	__ x x	Regenerative option Select a regenerative option. Incorrect setting may cause the regenerative option to burn. If a selected regenerative option is not for use with the driver, [AL. 37 Parameter error] occurs. 00: Regenerative option is not used. 02: LEC-LEC-MR-RB-032 03: LEC-LEC-MR-RB-12	00h	<input type="radio"/>	<input type="radio"/>	<input type="radio"/>
	_ x _ _	For manufacturer setting	0h	<input type="checkbox"/>	<input type="checkbox"/>	<input type="checkbox"/>
	x _ _ _		0h	<input type="checkbox"/>	<input type="checkbox"/>	<input type="checkbox"/>
PA03 *ABS Absolute position detection system	___ x	Absolute position detection system selection Set this digit when using the absolute position detection system. 0: Disabled (incremental system) 1: Enabled (absolute position detection system)	0h	<input type="radio"/>	<input type="radio"/>	<input type="radio"/>
	_ _ x _	For manufacturer setting	0h	<input type="checkbox"/>	<input type="checkbox"/>	<input type="checkbox"/>
	_ x _ _		0h	<input type="checkbox"/>	<input type="checkbox"/>	<input type="checkbox"/>
	x _ _ _		0h	<input type="checkbox"/>	<input type="checkbox"/>	<input type="checkbox"/>

5. PARAMETERS

No./ symbol/name	Setting digit	Function	Initial value [unit]	Network																								
				ECT	EIP	PNT																						
PA04 *AOP1 Function selection A-1	___x	For manufacturer setting	0h																									
	__x_		0h																									
	_x__	Servo forced stop selection 0: Enabled (The forced stop input EM2 or EM1 is used.) 1: Disabled (The forced stop input EM2 and EM1 are not used.) Refer to table 5.2 for details.	0h	○	○	○																						
	x___	Forced stop deceleration function selection 0: Forced stop deceleration function disabled (EM1) 2: Forced stop deceleration function enabled (EM2) Refer to table 5.2 for details.	2h	○	○	○																						
Table 5.2 Deceleration method																												
<table border="1" style="width: 100%; border-collapse: collapse;"> <thead> <tr> <th rowspan="2">Setting value</th> <th rowspan="2">EM2/EM1</th> <th colspan="2">Deceleration method</th> </tr> <tr> <th>EM2 or EM1 is off</th> <th>Alarm occurred</th> </tr> </thead> <tbody> <tr> <td>00__</td> <td>EM1</td> <td>MBR (Electromagnetic brake interlock) turns off without the forced stop deceleration.</td> <td>MBR (Electromagnetic brake interlock) turns off without the forced stop deceleration.</td> </tr> <tr> <td>20__</td> <td>EM2</td> <td>MBR (Electromagnetic brake interlock) turns off after the forced stop deceleration.</td> <td>MBR (Electromagnetic brake interlock) turns off after the forced stop deceleration.</td> </tr> <tr> <td>01__</td> <td>Not using EM2 and EM1</td> <td style="text-align: center;">/</td> <td>MBR (Electromagnetic brake interlock) turns off without the forced stop deceleration.</td> </tr> <tr> <td>21__</td> <td>Not using EM2 and EM1</td> <td style="text-align: center;">/</td> <td>MBR (Electromagnetic brake interlock) turns off after the forced stop deceleration.</td> </tr> </tbody> </table>							Setting value	EM2/EM1	Deceleration method		EM2 or EM1 is off	Alarm occurred	00__	EM1	MBR (Electromagnetic brake interlock) turns off without the forced stop deceleration.	MBR (Electromagnetic brake interlock) turns off without the forced stop deceleration.	20__	EM2	MBR (Electromagnetic brake interlock) turns off after the forced stop deceleration.	MBR (Electromagnetic brake interlock) turns off after the forced stop deceleration.	01__	Not using EM2 and EM1	/	MBR (Electromagnetic brake interlock) turns off without the forced stop deceleration.	21__	Not using EM2 and EM1	/	MBR (Electromagnetic brake interlock) turns off after the forced stop deceleration.
Setting value	EM2/EM1	Deceleration method																										
		EM2 or EM1 is off	Alarm occurred																									
00__	EM1	MBR (Electromagnetic brake interlock) turns off without the forced stop deceleration.	MBR (Electromagnetic brake interlock) turns off without the forced stop deceleration.																									
20__	EM2	MBR (Electromagnetic brake interlock) turns off after the forced stop deceleration.	MBR (Electromagnetic brake interlock) turns off after the forced stop deceleration.																									
01__	Not using EM2 and EM1	/	MBR (Electromagnetic brake interlock) turns off without the forced stop deceleration.																									
21__	Not using EM2 and EM1	/	MBR (Electromagnetic brake interlock) turns off after the forced stop deceleration.																									

5. PARAMETERS

No./ symbol/name	Setting digit	Function	Initial value [unit]	Network		
				ECT	EIP	PNT
PA06 *CMX Electronic gear numerator		<ul style="list-style-type: none"> In the cyclic synchronous mode Set an electronic gear numerator. The following shows the recommended range of the electronic gear ratio. Refer to section 5.4.1 for details. $\frac{1}{10} < \frac{CMX}{CDV} < 4000$ If any value other than the recommended range is set, noise may be generated during acceleration/deceleration. In the profile mode and the positioning mode (point table method) Set an electronic gear numerator. Set the electronic gear within the following range. Setting out of the range will trigger [AL. 37 Parameter error]. Refer to section 5.4.1 for details. $\frac{1}{865} < \frac{CMX}{CDV} < 271471$ In the positioning mode (indexer method) Set the number of gear teeth on machine side. Set the electronic gear within the following range. Refer to section 5.4.2 for details. <ul style="list-style-type: none"> (1) $1 \leq CMX \leq 16384, 1 \leq CDV \leq 16384$ (2) $\frac{1}{9999} \leq \frac{CMX}{CDV} \leq 9999$ (3) $CDV \times STN \leq 32767$ (STN: Number of stations per rotation [Pr. PT28]) (4) $CMX \times CDV \leq 100000$ <p>Setting out of the range will trigger [AL. 37 Parameter error]. When a small value is set to the electronic gear ratio with the manual operation mode, the servo motor may not drive at the set servo motor speed.</p> <p>Travel distance of 1 station = P_1 (servo motor resolution) $\times \frac{1}{STN} \times \frac{CMX}{CDV}$</p> <p>This parameter corresponds to "Motor revolutions (Index: 6091h, Sub: 1)". When this parameter is mapped for the PDO communication, the value written with Setup software (MR Configurator2™) is overwritten with the upper side. Thus, do not write a value with Setup software (MR Configurator2™).</p> <p>Setting range: 1 to 16777215</p>	1	○		
PA06 *CMX Electronic gear numerator		<p>Set an electronic gear numerator. Set the electronic gear within the following range. Setting out of the range will trigger [AL. 37 Parameter error]. Refer to section 5.4.1 for details.</p> $\frac{1}{865} < \frac{CMX}{CDV} < 271471$ <p>This parameter corresponds to "Motor revolutions (Class ID: 64h, Ins ID: 6091h, Attr ID: 1)". When this parameter is mapped for the I/O communication, the value written with Setup software (MR Configurator2™) is overwritten with the upper side. Thus, do not write a value with Setup software (MR Configurator2™).</p> <p>Setting range: 1 to 16777215</p>	1		○	

5. PARAMETERS

No./ symbol/name	Setting digit	Function	Initial value [unit]	Network		
				ECT	EIP	PNT
PA06 *CMX Electronic gear numerator		<ul style="list-style-type: none"> In the profile mode and the positioning mode (point table method) Set an electronic gear numerator. Set the electronic gear within the following range. Setting out of the range will trigger [AL. 37 Parameter error]. Refer to section 5.4.1 for details. $\frac{1}{865} < \frac{CMX}{CDV} < 271471$ In the positioning mode (indexer method) Set the number of gear teeth on machine side. Set the electronic gear within the following range. Refer to section 5.4.2 for details. (1) $1 \leq CMX \leq 16384, 1 \leq CDV \leq 16384$ (2) $\frac{1}{9999} \leq \frac{CMX}{CDV} \leq 9999$ (3) $CDV \times STN \leq 32767$ (STN: Number of stations per rotation [Pr. PT28]) (4) $CMX \times CDV \leq 100000$ Setting out of the range will trigger [AL. 37 Parameter error]. When a small value is set to the electronic gear ratio with the manual operation mode, the servo motor may not drive at the set servo motor speed. Travel distance of 1 station = P_r (servo motor resolution) $\times \frac{1}{STN} \times \frac{CMX}{CDV}$ <p>This parameter corresponds to "Motor revolutions (PNU: 24721, Sub: 0)". When this parameter is mapped for the Process Data communication, the value written with Setup software (MR Configurator2™) is overwritten with the upper side. Thus, do not write a value with Setup software (MR Configurator2™).</p> <p>Setting range: 1 to 1677215</p>	1			○

5. PARAMETERS

No./ symbol/name	Setting digit	Function	Initial value [unit]	Network		
				ECT	EIP	PNT
PA07 *CDV Electronic gear denominator		<p>Set an electronic gear denominator. In the indexer method, set the number of gear teeth on servo motor side. Set the value within the range of [Pr. PA06].</p> <p>This parameter corresponds to "Shaft revolutions (Index: 6091h, Sub: 2)". When this parameter is mapped for the PDO communication, the value written with Setup software (MR Configurator2™) is overwritten with the upper side. Thus, do not write a value with Setup software (MR Configurator2™).</p> <p>Setting range: 1 to 16777215</p>	1	<input type="radio"/>		
		<p>Set an electronic gear denominator. Set the value within the range of [Pr. PA06].</p> <p>This parameter corresponds to "Shaft revolutions (Class ID: 64h, Ins ID: 6091h, Attr ID: 2)". When this parameter is mapped for the I/O communication, the value written with Setup software (MR Configurator2™) is overwritten with the upper side. Thus, do not write a value with Setup software (MR Configurator2™).</p> <p>Setting range: 1 to 16777215</p>	1		<input type="radio"/>	
		<p>Set an electronic gear denominator. In the indexer method, set the number of gear teeth on servo motor side. Set the value within the range of [Pr. PA06].</p> <p>This parameter corresponds to "Shaft revolutions (PNU: 24721, Sub: 1)". When this parameter is mapped for the Process Data communication, the value written with Setup software (MR Configurator2™) is overwritten with the upper side. Thus, do not write a value with Setup software (MR Configurator2™).</p> <p>Setting range: 1 to 16777215</p>	1			<input type="radio"/>

5. PARAMETERS

No./ symbol/name	Setting digit	Function	Initial value [unit]	Network																				
				ECT	EIP	PNT																		
PA08 ATU Auto tuning mode	___x	Gain adjustment mode selection Select the gain adjustment mode. 0: 2 gain adjustment mode 1 (interpolation mode) 1: Auto tuning mode 1 2: Auto tuning mode 2 3: Manual mode 4: 2 gain adjustment mode 2 Refer to table 5.3 for details.	1h	<input type="radio"/>	<input type="radio"/>	<input type="radio"/>																		
	__x_	For manufacturer setting	0h	<input type="checkbox"/>	<input type="checkbox"/>	<input type="checkbox"/>																		
	_x__		0h	<input type="checkbox"/>	<input type="checkbox"/>	<input type="checkbox"/>																		
	x___		0h	<input type="checkbox"/>	<input type="checkbox"/>	<input type="checkbox"/>																		
<p>Table 5.3 Gain adjustment mode selection</p> <table border="1"> <thead> <tr> <th>Setting value</th> <th>Gain adjustment mode</th> <th>Automatically adjusted parameter</th> </tr> </thead> <tbody> <tr> <td>___0</td> <td>2 gain adjustment mode 1 (interpolation mode)</td> <td>[Pr. PB06 Load to motor inertia ratio] [Pr. PB08 Position loop gain] [Pr. PB09 Speed loop gain] [Pr. PB10 Speed integral compensation]</td> </tr> <tr> <td>___1</td> <td>Auto tuning mode 1</td> <td>[Pr. PB06 Load to motor inertia ratio] [Pr. PB07 Model loop gain] [Pr. PB08 Position loop gain] [Pr. PB09 Speed loop gain] [Pr. PB10 Speed integral compensation]</td> </tr> <tr> <td>___2</td> <td>Auto tuning mode 2</td> <td>[Pr. PB07 Model loop gain] [Pr. PB08 Position loop gain] [Pr. PB09 Speed loop gain] [Pr. PB10 Speed integral compensation]</td> </tr> <tr> <td>___3</td> <td>Manual mode</td> <td></td> </tr> <tr> <td>___4</td> <td>2 gain adjustment mode 2</td> <td>[Pr. PB08 Position loop gain] [Pr. PB09 Speed loop gain] [Pr. PB10 Speed integral compensation]</td> </tr> </tbody> </table>							Setting value	Gain adjustment mode	Automatically adjusted parameter	___0	2 gain adjustment mode 1 (interpolation mode)	[Pr. PB06 Load to motor inertia ratio] [Pr. PB08 Position loop gain] [Pr. PB09 Speed loop gain] [Pr. PB10 Speed integral compensation]	___1	Auto tuning mode 1	[Pr. PB06 Load to motor inertia ratio] [Pr. PB07 Model loop gain] [Pr. PB08 Position loop gain] [Pr. PB09 Speed loop gain] [Pr. PB10 Speed integral compensation]	___2	Auto tuning mode 2	[Pr. PB07 Model loop gain] [Pr. PB08 Position loop gain] [Pr. PB09 Speed loop gain] [Pr. PB10 Speed integral compensation]	___3	Manual mode		___4	2 gain adjustment mode 2	[Pr. PB08 Position loop gain] [Pr. PB09 Speed loop gain] [Pr. PB10 Speed integral compensation]
Setting value	Gain adjustment mode	Automatically adjusted parameter																						
___0	2 gain adjustment mode 1 (interpolation mode)	[Pr. PB06 Load to motor inertia ratio] [Pr. PB08 Position loop gain] [Pr. PB09 Speed loop gain] [Pr. PB10 Speed integral compensation]																						
___1	Auto tuning mode 1	[Pr. PB06 Load to motor inertia ratio] [Pr. PB07 Model loop gain] [Pr. PB08 Position loop gain] [Pr. PB09 Speed loop gain] [Pr. PB10 Speed integral compensation]																						
___2	Auto tuning mode 2	[Pr. PB07 Model loop gain] [Pr. PB08 Position loop gain] [Pr. PB09 Speed loop gain] [Pr. PB10 Speed integral compensation]																						
___3	Manual mode																							
___4	2 gain adjustment mode 2	[Pr. PB08 Position loop gain] [Pr. PB09 Speed loop gain] [Pr. PB10 Speed integral compensation]																						

5. PARAMETERS

No./ symbol/name	Setting digit	Function	Initial value [unit]	Network																																																																																													
				ECT	EIP	PNT																																																																																											
PA09 RSP Auto tuning response	Set the auto tuning response.		16	○	○	○																																																																																											
	<table border="1"> <thead> <tr> <th rowspan="2">Setting value</th> <th colspan="2">Machine characteristic</th> <th rowspan="2">Setting value</th> <th colspan="2">Machine characteristic</th> </tr> <tr> <th>Response</th> <th>Guideline for machine resonance frequency [Hz]</th> <th>Response</th> <th>Guideline for machine resonance frequency [Hz]</th> </tr> </thead> <tbody> <tr> <td>1</td> <td rowspan="10">Low response ↑</td> <td>2.7</td> <td>21</td> <td rowspan="10">Middle response ↑</td> <td>67.1</td> </tr> <tr> <td>2</td> <td>3.6</td> <td>22</td> <td>75.6</td> </tr> <tr> <td>3</td> <td>4.9</td> <td>23</td> <td>85.2</td> </tr> <tr> <td>4</td> <td>6.6</td> <td>24</td> <td>95.9</td> </tr> <tr> <td>5</td> <td>10.0</td> <td>25</td> <td>108.0</td> </tr> <tr> <td>6</td> <td>11.3</td> <td>26</td> <td>121.7</td> </tr> <tr> <td>7</td> <td>12.7</td> <td>27</td> <td>137.1</td> </tr> <tr> <td>8</td> <td>14.3</td> <td>28</td> <td>154.4</td> </tr> <tr> <td>9</td> <td>16.1</td> <td>29</td> <td>173.9</td> </tr> <tr> <td>10</td> <td>18.1</td> <td>30</td> <td>195.9</td> </tr> <tr> <td>11</td> <td rowspan="10">↓ Middle response</td> <td>20.4</td> <td>31</td> <td rowspan="10">↓ High response</td> <td>220.6</td> </tr> <tr> <td>12</td> <td>23.0</td> <td>32</td> <td>248.5</td> </tr> <tr> <td>13</td> <td>25.9</td> <td>33</td> <td>279.9</td> </tr> <tr> <td>14</td> <td>29.2</td> <td>34</td> <td>315.3</td> </tr> <tr> <td>15</td> <td>32.9</td> <td>35</td> <td>355.1</td> </tr> <tr> <td>16</td> <td>37.0</td> <td>36</td> <td>400.0</td> </tr> <tr> <td>17</td> <td>41.7</td> <td>37</td> <td>446.6</td> </tr> <tr> <td>18</td> <td>47.0</td> <td>38</td> <td>501.2</td> </tr> <tr> <td>19</td> <td>52.9</td> <td>39</td> <td>571.5</td> </tr> <tr> <td>20</td> <td>59.6</td> <td>40</td> <td>642.7</td> </tr> </tbody> </table>	Setting value					Machine characteristic		Setting value	Machine characteristic		Response	Guideline for machine resonance frequency [Hz]	Response	Guideline for machine resonance frequency [Hz]	1	Low response ↑	2.7	21	Middle response ↑	67.1	2	3.6	22	75.6	3	4.9	23	85.2	4	6.6	24	95.9	5	10.0	25	108.0	6	11.3	26	121.7	7	12.7	27	137.1	8	14.3	28	154.4	9	16.1	29	173.9	10	18.1	30	195.9	11	↓ Middle response	20.4	31	↓ High response	220.6	12	23.0	32	248.5	13	25.9	33	279.9	14	29.2	34	315.3	15	32.9	35	355.1	16	37.0	36	400.0	17	41.7	37	446.6	18	47.0	38	501.2	19	52.9	39	571.5	20	59.6
Setting value	Machine characteristic		Setting value	Machine characteristic																																																																																													
	Response	Guideline for machine resonance frequency [Hz]		Response	Guideline for machine resonance frequency [Hz]																																																																																												
1	Low response ↑	2.7	21	Middle response ↑	67.1																																																																																												
2		3.6	22		75.6																																																																																												
3		4.9	23		85.2																																																																																												
4		6.6	24		95.9																																																																																												
5		10.0	25		108.0																																																																																												
6		11.3	26		121.7																																																																																												
7		12.7	27		137.1																																																																																												
8		14.3	28		154.4																																																																																												
9		16.1	29		173.9																																																																																												
10		18.1	30		195.9																																																																																												
11	↓ Middle response	20.4	31	↓ High response	220.6																																																																																												
12		23.0	32		248.5																																																																																												
13		25.9	33		279.9																																																																																												
14		29.2	34		315.3																																																																																												
15		32.9	35		355.1																																																																																												
16		37.0	36		400.0																																																																																												
17		41.7	37		446.6																																																																																												
18		47.0	38		501.2																																																																																												
19		52.9	39		571.5																																																																																												
20		59.6	40		642.7																																																																																												
Setting range: 1 to 40																																																																																																	
PA10 INP In-position range	Set an in-position range per command pulse. To change it to the servo motor encoder pulse unit, set [Pr. PC06].		1600 Refer to Function column for unit.	○	○	○																																																																																											
	<table border="1"> <thead> <tr> <th>Pr. PA01</th> <th>In-position setting range</th> </tr> </thead> <tbody> <tr> <td>___ 0 (Automatic selection by each network)</td> <td rowspan="3">The range in which INP/S_INP (In-position) turns on</td> </tr> <tr> <td>___ 1 (Cyclic synchronous mode)</td> </tr> <tr> <td>___ 2 (Profile mode)</td> </tr> <tr> <td>___ 6 (Positioning mode (point table method))</td> <td rowspan="2">The range in which S_MEND (Travel completion) and INP/S_INP (In-position) turn on</td> </tr> <tr> <td>___ 8 (Positioning mode (indexer method))</td> </tr> </tbody> </table>						Pr. PA01	In-position setting range	___ 0 (Automatic selection by each network)	The range in which INP/S_INP (In-position) turns on	___ 1 (Cyclic synchronous mode)	___ 2 (Profile mode)	___ 6 (Positioning mode (point table method))	The range in which S_MEND (Travel completion) and INP/S_INP (In-position) turn on	___ 8 (Positioning mode (indexer method))																																																																																		
Pr. PA01	In-position setting range																																																																																																
___ 0 (Automatic selection by each network)	The range in which INP/S_INP (In-position) turns on																																																																																																
___ 1 (Cyclic synchronous mode)																																																																																																	
___ 2 (Profile mode)																																																																																																	
___ 6 (Positioning mode (point table method))	The range in which S_MEND (Travel completion) and INP/S_INP (In-position) turn on																																																																																																
___ 8 (Positioning mode (indexer method))																																																																																																	
<p>The unit will be as follows, depending on the control mode.</p> <ul style="list-style-type: none"> In the cyclic synchronous mode The unit is [pulse]. In the profile mode and the point table method When [Pr. PC06] is set to "___ 0", the unit can be changed to [μm], 10⁻⁴ [inch], 10⁻³ [degree] or [pulse] with the setting of [Pr. PT01]. When [Pr. PC06] is set to "___ 1", the unit is [pulse]. In the indexer method Command unit [pulse] (A load-side rotation expressed by the number of servo motor resolution pulses) For example, when making an in-position range "± 1 degree" for the rotation angle on the load side, set 4194304 × (1/360) = 11650 pulses. 																																																																																																	
Setting range: 0 to 65535																																																																																																	

5. PARAMETERS

No./ symbol/name	Setting digit	Function	Initial value [unit]	Network		
				ECT	EIP	PNT
PA11 TLP Forward rotation torque limit		<p>You can limit the torque generated by the servo motor.</p> <p>When torque is output with the analog monitor output, the setting of [Pr. PA11 Forward rotation torque limit/] or [Pr. PA12 Reverse rotation torque limit/], whichever is larger, will be the maximum output voltage (8 V).</p> <p>Set the parameter on the assumption that the rated torque or continuous thrust is 100.0 [%]. Set the parameter for limiting the torque of the servo motor in the CCW power running or CW regeneration, or for limiting the thrust of the linear servo motor in the positive direction power running or negative direction regeneration. Set this parameter to "0.0" to generate no torque .</p> <p>The polarity of the torque limit can be changed depending on the setting values of [Pr. PA14 Rotation direction selection/] and [Pr. PC29 POL reflection selection at torque mode].</p> <p>This parameter corresponds to "Positive torque limit value (Index: 60E0h)". When this parameter is mapped for the PDO communication, the value written with Setup software (MR Configurator2™) is overwritten with the upper side. Thus, do not write a value with Setup software (MR Configurator2™).</p> <p>Setting range: 0.0 to 1000.0</p>	1000.0 [%]	<input type="radio"/>		
		<p>You can limit the torque generated by the servo motor.</p> <p>When torque is output with the analog monitor output, the setting of [Pr. PA11 Forward rotation torque limit/] or [Pr. PA12 Reverse rotation torque limit/], whichever is larger, will be the maximum output voltage (8 V).</p> <p>Set the parameter on the assumption that the rated torque or continuous thrust is 100.0 [%]. Set the parameter for limiting the torque of the servo motor in the CCW power running or CW regeneration, or for limiting the thrust of the linear servo motor in the positive direction power running or negative direction regeneration. Set this parameter to "0.0" to generate no torque .</p> <p>The polarity of the torque limit can be changed depending on the setting values of [Pr. PA14 Rotation direction selection/] and [Pr. PC29 POL reflection selection at torque mode].</p> <p>This parameter corresponds to "Positive torque limit value (Class ID: 64h, Ins ID: 60E0h, Attr ID: 0)". When this parameter is mapped for the I/O communication, the value written with Setup software (MR Configurator2™) is overwritten with the upper side. Thus, do not write a value with Setup software (MR Configurator2™).</p> <p>Setting range: 0.0 to 1000.0</p>	1000.0 [%]		<input type="radio"/>	
		<p>You can limit the torque generated by the servo motor.</p> <p>When torque is output with the analog monitor output, the setting of [Pr. PA11 Forward rotation torque limit/] or [Pr. PA12 Reverse rotation torque limit/], whichever is larger, will be the maximum output voltage (8 V).</p> <p>Set the parameter on the assumption that the rated torque or continuous thrust is 100.0 [%]. Set the parameter for limiting the torque of the servo motor in the CCW power running or CW regeneration, or for limiting the thrust of the linear servo motor in the positive direction power running or negative direction regeneration. Set this parameter to "0.0" to generate no torque .</p> <p>The polarity of the torque limit can be changed depending on the setting values of [Pr. PA14 Rotation direction selection/] and [Pr. PC29 POL reflection selection at torque mode].</p> <p>This parameter corresponds to "Positive torque limit value (PNU: 24800, Sub: 0)". When this parameter is mapped for the Process Data communication, the value written with Setup software (MR Configurator2™) is overwritten with the upper side. Thus, do not write a value with Setup software (MR Configurator2™).</p> <p>Setting range: 0.0 to 1000.0</p>	1000.0 [%]			<input type="radio"/>

5. PARAMETERS

No./ symbol/name	Setting digit	Function	Initial value [unit]	Network		
				ECT	EIP	PNT
PA12 TLN Reverse rotation torque limit		<p>You can limit the torque generated by the servo motor.</p> <p>When torque is output with the analog monitor output, the setting of [Pr. PA11 Forward rotation torque limit/] or [Pr. PA12 Reverse rotation torque limit/], whichever is larger, will be the maximum output voltage (8 V).</p> <p>Set the parameter on the assumption that the rated torque or continuous thrust is 100.0 [%]. The parameter is for limiting the torque of the servo motor in the CW power running or CCW regeneration, or for limiting the thrust of the linear servo motor in the negative direction power running or positive direction regeneration. Set this parameter to "0.0" to generate no torque .</p> <p>The polarity of the torque limit can be changed depending on the setting values of [Pr. PA14 Rotation direction selection/] and [Pr. PC29 POL reflection selection at torque mode].</p> <p>This parameter corresponds to "Negative torque limit value (Index: 60E1)". When this parameter is mapped for the PDO communication, the value written with Setup software (MR Configurator2™) is overwritten with the upper side. Thus, do not write a value with Setup software (MR Configurator2™).</p> <p>Setting range: 0.0 to 1000.0</p>	1000.0 [%]	○		
		<p>You can limit the torque generated by the servo motor.</p> <p>When torque is output with the analog monitor output, the setting of [Pr. PA11 Forward rotation torque limit/] or [Pr. PA12 Reverse rotation torque limit/], whichever is larger, will be the maximum output voltage (8 V).</p> <p>Set the parameter on the assumption that the rated torque or continuous thrust is 100.0 [%]. The parameter is for limiting the torque of the servo motor in the CW power running or CCW regeneration, or for limiting the thrust of the linear servo motor in the negative direction power running or positive direction regeneration. Set this parameter to "0.0" to generate no torque .</p> <p>The polarity of the torque limit can be changed depending on the setting values of [Pr. PA14 Rotation direction selection/] and [Pr. PC29 POL reflection selection at torque mode].</p> <p>This parameter corresponds to "Negative torque limit value (Class ID: 64h, Ins ID: 60E1h, Attr ID: 0)". When this parameter is mapped for the I/O communication, the value written with Setup software (MR Configurator2™) is overwritten with the upper side. Thus, do not write a value with Setup software (MR Configurator2™).</p> <p>Setting range: 0.0 to 1000.0</p>	1000.0 [%]		○	
		<p>You can limit the torque generated by the servo motor.</p> <p>When torque is output with the analog monitor output, the setting of [Pr. PA11 Forward rotation torque limit/] or [Pr. PA12 Reverse rotation torque limit/], whichever is larger, will be the maximum output voltage (8 V).</p> <p>Set the parameter on the assumption that the rated torque or continuous thrust is 100.0 [%]. The parameter is for limiting the torque of the servo motor in the CW power running or CCW regeneration, or for limiting the thrust of the linear servo motor in the negative direction power running or positive direction regeneration. Set this parameter to "0.0" to generate no torque .</p> <p>The polarity of the torque limit can be changed depending on the setting values of [Pr. PA14 Rotation direction selection/] and [Pr. PC29 POL reflection selection at torque mode].</p> <p>This parameter corresponds to "Negative torque limit value (PNU: 24801, Sub: 0)". When this parameter is mapped for the Process Data communication, the value written with Setup software (MR Configurator2™) is overwritten with the upper side. Thus, do not write a value with Setup software (MR Configurator2™).</p> <p>Setting range: 0.0 to 1000.0</p>	1000.0 [%]			○

5. PARAMETERS

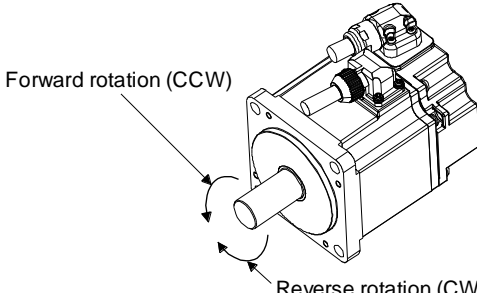
No./ symbol/name	Setting digit	Function	Initial value [unit]	Network																																			
				ECT	EIP	PNT																																	
PA14 *POL Rotation direction selection		<p>Select a rotation direction.</p> <p>You can enable or disable the following settings for the torque mode depending on the setting value of [Pr. PC29 POL reflection selection at torque mode].</p> <ul style="list-style-type: none"> At position mode/velocity mode <table border="1" style="margin-left: 20px;"> <thead> <tr> <th rowspan="2">Setting value</th> <th colspan="2">Servo motor rotation direction</th> </tr> <tr> <th>Position mode Positioning address increase/ Velocity mode Speed command: Positive</th> <th>Position mode Positioning address decrease/ Velocity mode Speed command: Negative</th> </tr> </thead> <tbody> <tr> <td>0</td> <td>CCW or positive direction</td> <td>CW or negative direction</td> </tr> <tr> <td>1</td> <td>CW or negative direction</td> <td>CCW or positive direction</td> </tr> </tbody> </table> <ul style="list-style-type: none"> At torque mode <table border="1" style="margin-left: 20px;"> <thead> <tr> <th colspan="2">Setting value</th> <th colspan="2">Servo motor rotation direction</th> </tr> <tr> <th>[Pr. PA14]</th> <th>[Pr. PC29]</th> <th>Torque mode Torque command: Positive</th> <th>Torque mode Torque command: Negative</th> </tr> </thead> <tbody> <tr> <td rowspan="2">0</td> <td>0 ___: Enabled</td> <td>CCW or positive direction</td> <td>CW or negative direction</td> </tr> <tr> <td>1 ___: Disabled</td> <td>CCW or positive direction</td> <td>CW or negative direction</td> </tr> <tr> <td rowspan="2">1</td> <td>0 ___: Enabled</td> <td>CW or negative direction</td> <td>CCW or positive direction</td> </tr> <tr> <td>1 ___: Disabled</td> <td>CCW or positive direction</td> <td>CW or negative direction</td> </tr> </tbody> </table> <p>The following shows the servo motor rotation directions.</p> <div style="text-align: center;">  </div> <p>The positive/negative directions of the linear servo motor are as follows.</p> <p>Setting range: 0, 1</p>	Setting value	Servo motor rotation direction		Position mode Positioning address increase/ Velocity mode Speed command: Positive	Position mode Positioning address decrease/ Velocity mode Speed command: Negative	0	CCW or positive direction	CW or negative direction	1	CW or negative direction	CCW or positive direction	Setting value		Servo motor rotation direction		[Pr. PA14]	[Pr. PC29]	Torque mode Torque command: Positive	Torque mode Torque command: Negative	0	0 ___: Enabled	CCW or positive direction	CW or negative direction	1 ___: Disabled	CCW or positive direction	CW or negative direction	1	0 ___: Enabled	CW or negative direction	CCW or positive direction	1 ___: Disabled	CCW or positive direction	CW or negative direction	0	<input type="radio"/>	<input type="radio"/>	<input type="radio"/>
Setting value	Servo motor rotation direction																																						
	Position mode Positioning address increase/ Velocity mode Speed command: Positive	Position mode Positioning address decrease/ Velocity mode Speed command: Negative																																					
0	CCW or positive direction	CW or negative direction																																					
1	CW or negative direction	CCW or positive direction																																					
Setting value		Servo motor rotation direction																																					
[Pr. PA14]	[Pr. PC29]	Torque mode Torque command: Positive	Torque mode Torque command: Negative																																				
0	0 ___: Enabled	CCW or positive direction	CW or negative direction																																				
	1 ___: Disabled	CCW or positive direction	CW or negative direction																																				
1	0 ___: Enabled	CW or negative direction	CCW or positive direction																																				
	1 ___: Disabled	CCW or positive direction	CW or negative direction																																				

5. PARAMETERS

No./ symbol/name	Setting digit	Function	Initial value [unit]	Network		
				ECT	EIP	PNT
PA15 *ENR Encoder output pulses		<p>Set the encoder output pulses from the driver by using the number of output pulses per revolution, dividing ratio, or electronic gear ratio. (after multiplication by 4)</p> <p>Selecting "Dividing ratio setting (_ _ 1 _)" of "Encoder output pulse setting selection" in [Pr. PC03] will divide the travel distance [pulse] of the linear encoder by the setting value.</p> <p>Set a numerator of the electronic gear for the A/B-phase pulse output when selecting "A-phase/B-phase pulse electronic gear setting (_ _ 3 _)" of "Encoder output pulse setting selection" in [Pr. PC03].</p> <p>Refer to app. 12 for details.</p> <p>The maximum output frequency is 4.6 Mpulses/s. Set the parameter within this range.</p> <p>Setting range: 1 to 4194304</p>	4000 [pulse/ rev]	<input type="radio"/>	<input type="radio"/>	<input type="radio"/>
PA16 *ENR2 Encoder output pulses 2		<p>Set a denominator of the electronic gear for the A/B-phase pulse output.</p> <p>Set a denominator of the electronic gear when selecting "A-phase/B-phase pulse electronic gear setting (_ _ 3 _)" of "Encoder output pulse setting selection" in [Pr. PC03].</p> <p>Selecting "Dividing ratio setting (_ _ 1 _)" of "Encoder output pulse setting selection" in [Pr. PC03] will disable the setting value.</p> <p>Refer to app. 11 for details.</p> <p>The maximum output frequency is 4.6 Mpulses/s. Set the parameter within this range.</p> <p>Setting range: 1 to 4194304</p>	1	<input type="radio"/>	<input type="radio"/>	<input type="radio"/>

No./ symbol/name	Setting digit	Function	Initial value [unit]	Network		
				ECT	EIP	PNT
PA17 **MSR Servo motor series setting		Do not change this value.	0000h	<input type="radio"/>	<input type="radio"/>	<input type="radio"/>
PA18 **MTY Servo motor type setting		Do not change this value.	0000h	<input type="radio"/>	<input type="radio"/>	<input type="radio"/>

5. PARAMETERS

No./ symbol/name	Setting digit	Function	Initial value [unit]	Network																																																																																																																																																																																																																																																																									
				ECT	EIP	PNT																																																																																																																																																																																																																																																																							
PA19 *BLK Parameter writing inhibit		Select a reference range and writing range of the parameter. Refer to table 5.4 for settings.	00ABh	<input type="radio"/>	<input type="radio"/>	<input type="radio"/>																																																																																																																																																																																																																																																																							
	Table 5.4 [Pr. PA19] setting value and reading/writing range																																																																																																																																																																																																																																																																												
<table border="1" style="width: 100%; border-collapse: collapse; text-align: center;"> <thead> <tr> <th>PA19</th> <th>Setting operation</th> <th>PA</th> <th>PB</th> <th>PC</th> <th>PD</th> <th>PE</th> <th>PF</th> <th>PL</th> <th>PT</th> <th>PN</th> </tr> </thead> <tbody> <tr> <td rowspan="2">Other than below</td> <td>Reading</td> <td><input type="radio"/></td> <td>/</td> <td>/</td> <td>/</td> <td>/</td> <td>/</td> <td>/</td> <td>/</td> <td>/</td> </tr> <tr> <td>Writing</td> <td><input type="radio"/></td> <td>/</td> <td>/</td> <td>/</td> <td>/</td> <td>/</td> <td>/</td> <td>/</td> <td>/</td> </tr> <tr> <td rowspan="2">000Ah</td> <td>Reading</td> <td>Only 19</td> <td>/</td> <td>/</td> <td>/</td> <td>/</td> <td>/</td> <td>/</td> <td>/</td> <td>/</td> </tr> <tr> <td>Writing</td> <td>Only 19</td> <td>/</td> <td>/</td> <td>/</td> <td>/</td> <td>/</td> <td>/</td> <td>/</td> <td>/</td> </tr> <tr> <td rowspan="2">000Bh</td> <td>Reading</td> <td><input type="radio"/></td> <td><input type="radio"/></td> <td><input type="radio"/></td> <td>/</td> <td>/</td> <td>/</td> <td>/</td> <td>/</td> <td>/</td> </tr> <tr> <td>Writing</td> <td><input type="radio"/></td> <td><input type="radio"/></td> <td><input type="radio"/></td> <td>/</td> <td>/</td> <td>/</td> <td>/</td> <td>/</td> <td>/</td> </tr> <tr> <td rowspan="2">000Ch</td> <td>Reading</td> <td><input type="radio"/></td> <td><input type="radio"/></td> <td><input type="radio"/></td> <td><input type="radio"/></td> <td>/</td> <td>/</td> <td>/</td> <td>/</td> <td>/</td> </tr> <tr> <td>Writing</td> <td><input type="radio"/></td> <td><input type="radio"/></td> <td><input type="radio"/></td> <td><input type="radio"/></td> <td>/</td> <td>/</td> <td>/</td> <td>/</td> <td>/</td> </tr> <tr> <td rowspan="2">000Fh</td> <td>Reading</td> <td><input type="radio"/></td> <td><input type="radio"/></td> <td><input type="radio"/></td> <td><input type="radio"/></td> <td><input type="radio"/></td> <td>/</td> <td><input type="radio"/></td> <td>/</td> <td>/</td> </tr> <tr> <td>Writing</td> <td><input type="radio"/></td> <td><input type="radio"/></td> <td><input type="radio"/></td> <td><input type="radio"/></td> <td><input type="radio"/></td> <td>/</td> <td><input type="radio"/></td> <td>/</td> <td>/</td> </tr> <tr> <td rowspan="2">00AAh</td> <td>Reading</td> <td><input type="radio"/></td> <td><input type="radio"/></td> <td><input type="radio"/></td> <td><input type="radio"/></td> <td><input type="radio"/></td> <td><input type="radio"/></td> <td>/</td> <td>/</td> <td>/</td> </tr> <tr> <td>Writing</td> <td><input type="radio"/></td> <td><input type="radio"/></td> <td><input type="radio"/></td> <td><input type="radio"/></td> <td><input type="radio"/></td> <td><input type="radio"/></td> <td>/</td> <td>/</td> <td>/</td> </tr> <tr> <td rowspan="2">00ABh (initial value)</td> <td>Reading</td> <td><input type="radio"/></td> <td><input type="radio"/></td> <td><input type="radio"/></td> <td><input type="radio"/></td> <td><input type="radio"/></td> <td><input type="radio"/></td> <td><input type="radio"/></td> <td><input type="radio"/></td> <td><input type="radio"/></td> </tr> <tr> <td>Writing</td> <td><input type="radio"/></td> <td><input type="radio"/></td> <td><input type="radio"/></td> <td><input type="radio"/></td> <td><input type="radio"/></td> <td><input type="radio"/></td> <td><input type="radio"/></td> <td><input type="radio"/></td> <td><input type="radio"/></td> </tr> <tr> <td rowspan="2">100Bh</td> <td>Reading</td> <td><input type="radio"/></td> <td>/</td> <td>/</td> <td>/</td> <td>/</td> <td>/</td> <td>/</td> <td>/</td> <td>/</td> </tr> <tr> <td>Writing</td> <td>Only 19</td> <td>/</td> <td>/</td> <td>/</td> <td>/</td> <td>/</td> <td>/</td> <td>/</td> <td>/</td> </tr> <tr> <td rowspan="2">100Ch</td> <td>Reading</td> <td><input type="radio"/></td> <td><input type="radio"/></td> <td><input type="radio"/></td> <td><input type="radio"/></td> <td>/</td> <td>/</td> <td>/</td> <td>/</td> <td>/</td> </tr> <tr> <td>Writing</td> <td>Only 19</td> <td>/</td> <td>/</td> <td>/</td> <td>/</td> <td>/</td> <td>/</td> <td>/</td> <td>/</td> </tr> <tr> <td rowspan="2">100Fh</td> <td>Reading</td> <td><input type="radio"/></td> <td><input type="radio"/></td> <td><input type="radio"/></td> <td><input type="radio"/></td> <td><input type="radio"/></td> <td>/</td> <td><input type="radio"/></td> <td>/</td> <td>/</td> </tr> <tr> <td>Writing</td> <td>Only 19</td> <td>/</td> <td>/</td> <td>/</td> <td>/</td> <td>/</td> <td>/</td> <td>/</td> <td>/</td> </tr> <tr> <td rowspan="2">10AAh</td> <td>Reading</td> <td><input type="radio"/></td> <td><input type="radio"/></td> <td><input type="radio"/></td> <td><input type="radio"/></td> <td><input type="radio"/></td> <td><input type="radio"/></td> <td>/</td> <td>/</td> <td>/</td> </tr> <tr> <td>Writing</td> <td>Only 19</td> <td>/</td> <td>/</td> <td>/</td> <td>/</td> <td>/</td> <td>/</td> <td>/</td> <td>/</td> </tr> <tr> <td rowspan="2">10ABh</td> <td>Reading</td> <td><input type="radio"/></td> <td><input type="radio"/></td> <td><input type="radio"/></td> <td><input type="radio"/></td> <td><input type="radio"/></td> <td><input type="radio"/></td> <td><input type="radio"/></td> <td><input type="radio"/></td> <td><input type="radio"/></td> </tr> <tr> <td>Writing</td> <td>Only 19</td> <td>/</td> <td>/</td> <td>/</td> <td>/</td> <td>/</td> <td>/</td> <td>/</td> <td>/</td> </tr> </tbody> </table>							PA19	Setting operation	PA	PB	PC	PD	PE	PF	PL	PT	PN	Other than below	Reading	<input type="radio"/>	/	/	/	/	/	/	/	/	Writing	<input type="radio"/>	/	/	/	/	/	/	/	/	000Ah	Reading	Only 19	/	/	/	/	/	/	/	/	Writing	Only 19	/	/	/	/	/	/	/	/	000Bh	Reading	<input type="radio"/>	<input type="radio"/>	<input type="radio"/>	/	/	/	/	/	/	Writing	<input type="radio"/>	<input type="radio"/>	<input type="radio"/>	/	/	/	/	/	/	000Ch	Reading	<input type="radio"/>	<input type="radio"/>	<input type="radio"/>	<input type="radio"/>	/	/	/	/	/	Writing	<input type="radio"/>	<input type="radio"/>	<input type="radio"/>	<input type="radio"/>	/	/	/	/	/	000Fh	Reading	<input type="radio"/>	<input type="radio"/>	<input type="radio"/>	<input type="radio"/>	<input type="radio"/>	/	<input type="radio"/>	/	/	Writing	<input type="radio"/>	<input type="radio"/>	<input type="radio"/>	<input type="radio"/>	<input type="radio"/>	/	<input type="radio"/>	/	/	00AAh	Reading	<input type="radio"/>	<input type="radio"/>	<input type="radio"/>	<input type="radio"/>	<input type="radio"/>	<input type="radio"/>	/	/	/	Writing	<input type="radio"/>	<input type="radio"/>	<input type="radio"/>	<input type="radio"/>	<input type="radio"/>	<input type="radio"/>	/	/	/	00ABh (initial value)	Reading	<input type="radio"/>	<input type="radio"/>	<input type="radio"/>	<input type="radio"/>	<input type="radio"/>	<input type="radio"/>	<input type="radio"/>	<input type="radio"/>	<input type="radio"/>	Writing	<input type="radio"/>	<input type="radio"/>	<input type="radio"/>	<input type="radio"/>	<input type="radio"/>	<input type="radio"/>	<input type="radio"/>	<input type="radio"/>	<input type="radio"/>	100Bh	Reading	<input type="radio"/>	/	/	/	/	/	/	/	/	Writing	Only 19	/	/	/	/	/	/	/	/	100Ch	Reading	<input type="radio"/>	<input type="radio"/>	<input type="radio"/>	<input type="radio"/>	/	/	/	/	/	Writing	Only 19	/	/	/	/	/	/	/	/	100Fh	Reading	<input type="radio"/>	<input type="radio"/>	<input type="radio"/>	<input type="radio"/>	<input type="radio"/>	/	<input type="radio"/>	/	/	Writing	Only 19	/	/	/	/	/	/	/	/	10AAh	Reading	<input type="radio"/>	<input type="radio"/>	<input type="radio"/>	<input type="radio"/>	<input type="radio"/>	<input type="radio"/>	/	/	/	Writing	Only 19	/	/	/	/	/	/	/	/	10ABh	Reading	<input type="radio"/>	<input type="radio"/>	<input type="radio"/>	<input type="radio"/>	<input type="radio"/>	<input type="radio"/>	<input type="radio"/>	<input type="radio"/>	<input type="radio"/>	Writing	Only 19	/	/	/	/	/	/	/	/
PA19	Setting operation	PA	PB	PC	PD	PE	PF	PL	PT	PN																																																																																																																																																																																																																																																																			
Other than below	Reading	<input type="radio"/>	/	/	/	/	/	/	/	/																																																																																																																																																																																																																																																																			
	Writing	<input type="radio"/>	/	/	/	/	/	/	/	/																																																																																																																																																																																																																																																																			
000Ah	Reading	Only 19	/	/	/	/	/	/	/	/																																																																																																																																																																																																																																																																			
	Writing	Only 19	/	/	/	/	/	/	/	/																																																																																																																																																																																																																																																																			
000Bh	Reading	<input type="radio"/>	<input type="radio"/>	<input type="radio"/>	/	/	/	/	/	/																																																																																																																																																																																																																																																																			
	Writing	<input type="radio"/>	<input type="radio"/>	<input type="radio"/>	/	/	/	/	/	/																																																																																																																																																																																																																																																																			
000Ch	Reading	<input type="radio"/>	<input type="radio"/>	<input type="radio"/>	<input type="radio"/>	/	/	/	/	/																																																																																																																																																																																																																																																																			
	Writing	<input type="radio"/>	<input type="radio"/>	<input type="radio"/>	<input type="radio"/>	/	/	/	/	/																																																																																																																																																																																																																																																																			
000Fh	Reading	<input type="radio"/>	<input type="radio"/>	<input type="radio"/>	<input type="radio"/>	<input type="radio"/>	/	<input type="radio"/>	/	/																																																																																																																																																																																																																																																																			
	Writing	<input type="radio"/>	<input type="radio"/>	<input type="radio"/>	<input type="radio"/>	<input type="radio"/>	/	<input type="radio"/>	/	/																																																																																																																																																																																																																																																																			
00AAh	Reading	<input type="radio"/>	<input type="radio"/>	<input type="radio"/>	<input type="radio"/>	<input type="radio"/>	<input type="radio"/>	/	/	/																																																																																																																																																																																																																																																																			
	Writing	<input type="radio"/>	<input type="radio"/>	<input type="radio"/>	<input type="radio"/>	<input type="radio"/>	<input type="radio"/>	/	/	/																																																																																																																																																																																																																																																																			
00ABh (initial value)	Reading	<input type="radio"/>	<input type="radio"/>	<input type="radio"/>	<input type="radio"/>	<input type="radio"/>	<input type="radio"/>	<input type="radio"/>	<input type="radio"/>	<input type="radio"/>																																																																																																																																																																																																																																																																			
	Writing	<input type="radio"/>	<input type="radio"/>	<input type="radio"/>	<input type="radio"/>	<input type="radio"/>	<input type="radio"/>	<input type="radio"/>	<input type="radio"/>	<input type="radio"/>																																																																																																																																																																																																																																																																			
100Bh	Reading	<input type="radio"/>	/	/	/	/	/	/	/	/																																																																																																																																																																																																																																																																			
	Writing	Only 19	/	/	/	/	/	/	/	/																																																																																																																																																																																																																																																																			
100Ch	Reading	<input type="radio"/>	<input type="radio"/>	<input type="radio"/>	<input type="radio"/>	/	/	/	/	/																																																																																																																																																																																																																																																																			
	Writing	Only 19	/	/	/	/	/	/	/	/																																																																																																																																																																																																																																																																			
100Fh	Reading	<input type="radio"/>	<input type="radio"/>	<input type="radio"/>	<input type="radio"/>	<input type="radio"/>	/	<input type="radio"/>	/	/																																																																																																																																																																																																																																																																			
	Writing	Only 19	/	/	/	/	/	/	/	/																																																																																																																																																																																																																																																																			
10AAh	Reading	<input type="radio"/>	<input type="radio"/>	<input type="radio"/>	<input type="radio"/>	<input type="radio"/>	<input type="radio"/>	/	/	/																																																																																																																																																																																																																																																																			
	Writing	Only 19	/	/	/	/	/	/	/	/																																																																																																																																																																																																																																																																			
10ABh	Reading	<input type="radio"/>	<input type="radio"/>	<input type="radio"/>	<input type="radio"/>	<input type="radio"/>	<input type="radio"/>	<input type="radio"/>	<input type="radio"/>	<input type="radio"/>																																																																																																																																																																																																																																																																			
	Writing	Only 19	/	/	/	/	/	/	/	/																																																																																																																																																																																																																																																																			
PA20 *TDS Tough drive setting		Alarms may not be avoided with the tough drive function depending on the situations of the power supply and load fluctuation. You can assign MTTR (During tough drive) to pins CN3-9, CN3-13, and CN3-15 with [Pr. PD07] to [Pr. PD09].																																																																																																																																																																																																																																																																											
	___x	For manufacturer setting	0h	/	/	/																																																																																																																																																																																																																																																																							
	__x_	Vibration tough drive selection 0: Disabled 1: Enabled Selecting "1" enables to suppress vibrations by automatically changing the setting values of [Pr. PB13 Machine resonance suppression filter 1] and [Pr. PB15 Machine resonance suppression filter 2] in case that the vibration exceeds the value of the oscillation level set in [Pr. PF23]. The parameter will operate when [Pr. PB13 Machine resonance suppression filter 1] and [Pr. PB15 Machine resonance suppression filter 2] are enabled. Refer to section 7.3 for details.	0h	<input type="radio"/>	<input type="radio"/>	<input type="radio"/>																																																																																																																																																																																																																																																																							
	_x__	SEMI-F47 function selection 0: Disabled 1: Enabled Selecting "1" enables to avoid triggering [AL. 10 Undervoltage] using the electrical energy charged in the capacitor in case that an instantaneous power failure occurs during operation. In [Pr. PF25 SEMI-F47 function - Instantaneous power failure detection time], set the time until the occurrence of [AL. 10.1 Voltage drop in the control circuit power].	0h	<input type="radio"/>	<input type="radio"/>	<input type="radio"/>																																																																																																																																																																																																																																																																							
x___	For manufacturer setting	0h	/	/	/																																																																																																																																																																																																																																																																								

5. PARAMETERS

No./ symbol/name	Setting digit	Function	Initial value [unit]	Network		
				ECT	EIP	PNT
PA21 *AOP3 Function selection A-3	___x	One-touch tuning function selection 0: Disabled 1: Enabled When this digit is "0", the one-touch tuning will be disabled.	1h	<input type="radio"/>	<input type="radio"/>	<input type="radio"/>
	__x_	For manufacturer setting	0h	<input type="checkbox"/>	<input type="checkbox"/>	<input type="checkbox"/>
	_x__		0h	<input type="checkbox"/>	<input type="checkbox"/>	<input type="checkbox"/>
	x___		0h	<input type="checkbox"/>	<input type="checkbox"/>	<input type="checkbox"/>
PA22 **PCS Position control composition selection	___x	For manufacturer setting	0h	<input type="checkbox"/>	<input type="checkbox"/>	<input type="checkbox"/>
	__x_	Super trace control selection 0: Disabled 2: Enabled	0h	<input type="radio"/>	<input type="radio"/>	<input type="radio"/>
	_x__	For manufacturer setting	0h	<input type="checkbox"/>	<input type="checkbox"/>	<input type="checkbox"/>
	x___	Scale measurement function selection Do not change this value.	0h	<input type="radio"/>	<input type="radio"/>	<input type="checkbox"/>
PA23 DRAT Drive recorder arbitrary alarm trigger setting	__xx	Alarm detail No. setting Set the digits when you execute the trigger with arbitrary alarm detail No. for the drive recorder function. When these digits are "0 0", only the arbitrary alarm No. setting will be enabled.	00h	<input type="radio"/>	<input type="radio"/>	<input type="radio"/>
	xx__	Alarm No. setting Set the digits when you execute the trigger with arbitrary alarm No. for the drive recorder function. When "0 0" are set, arbitrary alarm trigger of the drive recorder will be disabled.	00h	<input type="radio"/>	<input type="radio"/>	<input type="radio"/>
	Setting example: To activate the drive recorder when [AL. 50 Overload 1] occurs, set "5 0 0 0". To activate the drive recorder when [AL. 50.3 Thermal overload error 4 during operation] occurs, set "5 0 0 3".					
PA24 AOP4 Function selection A-4	___x	Vibration suppression mode selection 0: Standard mode 1: 3 inertia mode 2: Low response mode When you select the standard mode or low response mode, "Vibration suppression control 2" is not available. When you select the 3 inertia mode, the feed forward gain is not available. Before changing the control mode during the 3 inertia mode or low response mode, stop the motor.	0h	<input type="radio"/>	<input type="radio"/>	<input type="radio"/>
	__x_	For manufacturer setting	0h	<input type="checkbox"/>	<input type="checkbox"/>	<input type="checkbox"/>
	_x__		0h	<input type="checkbox"/>	<input type="checkbox"/>	<input type="checkbox"/>
	x___		0h	<input type="checkbox"/>	<input type="checkbox"/>	<input type="checkbox"/>

5. PARAMETERS

No./ symbol/name	Setting digit	Function	Initial value [unit]	Network		
				ECT	EIP	PNT
PA25 OTHOV One-touch tuning - Overshoot permissible level		Set a permissible value of overshoot amount for one-touch tuning as a percentage of the in-position range. Note that setting "0" will be 50%. Setting range: 0 to 100	0 [%]	<input type="radio"/>	<input type="radio"/>	<input type="radio"/>
PA26 *AOP5 Function selection A-5	___x	Torque limit function selection at instantaneous power failure 0: Disabled 1: Enabled When an instantaneous power failure occurs during operation, you can save electric energy charged in the capacitor in the driver by limiting torque at acceleration. You can also delay the time until [AL. 10.2 Voltage drop in the main circuit power] occurs with instantaneous power failure tough drive function. Doing this will enable you to set a longer time in [Pr. PF25 SEMI-F47 function - Instantaneous power failure detection time]. The torque limit function at instantaneous power failure is enabled when "SEMI-F47 function selection" in [Pr. PA20] is "Enabled (_ 1 _)".	0h	<input type="radio"/>	<input type="radio"/>	<input type="radio"/>
	__x_	For manufacturer setting	0h	<input type="checkbox"/>	<input type="checkbox"/>	<input type="checkbox"/>
	_x__		0h	<input type="checkbox"/>	<input type="checkbox"/>	<input type="checkbox"/>
	x___		0h	<input type="checkbox"/>	<input type="checkbox"/>	<input type="checkbox"/>

5.2.2 Gain/filter setting parameters ([Pr. PB_ _])

No./ symbol/name	Setting digit	Function	Initial value [unit]	Network		
				ECT	EIP	PNT
PB01 FILT Adaptive tuning mode (adaptive filter II)	___x	Filter tuning mode selection Set the adaptive tuning. Select the adjustment mode of the machine resonance suppression filter 1. Refer to section 7.1.2 for details. 0: Disabled 1: Automatic setting 2: Manual setting	0h	<input type="radio"/>	<input type="radio"/>	<input type="radio"/>
	__x_	For manufacturer setting	0h	<input type="checkbox"/>	<input type="checkbox"/>	<input type="checkbox"/>
	_x__		0h	<input type="checkbox"/>	<input type="checkbox"/>	<input type="checkbox"/>
	x___		0h	<input type="checkbox"/>	<input type="checkbox"/>	<input type="checkbox"/>
PB02 VRFT Vibration suppression control tuning mode (advanced vibration suppression control II)	___x	Vibration suppression control 1 tuning mode selection Select the tuning mode of the vibration suppression control 1. Refer to section 7.1.5 for details. 0: Disabled 1: Automatic setting 2: Manual setting	0h	<input type="radio"/>	<input type="radio"/>	<input type="radio"/>
	__x_	Vibration suppression control 2 tuning mode selection Select the tuning mode of the vibration suppression control 2. To enable the digit, set "Vibration suppression mode selection" to "3 inertia mode (_ _ _ 1)" in [Pr. PA24]. Refer to section 7.1.5 for details. 0: Disabled 1: Automatic setting 2: Manual setting	0h	<input type="radio"/>	<input type="radio"/>	<input type="radio"/>
	_x__	For manufacturer setting	0h	<input type="checkbox"/>	<input type="checkbox"/>	<input type="checkbox"/>
	x___		0h	<input type="checkbox"/>	<input type="checkbox"/>	<input type="checkbox"/>

5. PARAMETERS

No./ symbol/name	Setting digit	Function	Initial value [unit]	Network												
				ECT	EIP	PNT										
PB04 FFC Feed forward gain		<p>Set the feed forward gain. When the setting is 100%, the droop pulses during operation at constant speed will be almost 0. When the super trace control is enabled, constant speed and uniform acceleration/deceleration droop pulses will be almost 0. However, sudden acceleration/deceleration will increase the overshoot. As a guideline, when the feed forward gain setting is 100%, set 1 s or more for the acceleration time constant to the rated speed.</p> <p>Setting range: 0 to 100</p>	0 [%]	<input type="radio"/>	<input type="radio"/>	<input type="radio"/>										
PB06 GD2 Load to motor inertia ratio/		<p>Set a load to motor inertia ratio or . Setting a value considerably different from the actual load moment of inertia or load mass may cause an unexpected operation such as an overshoot. The setting of this parameter will be automatic or manual depending on the setting of [Pr. PA08]. Refer to the following table for details. When the parameter is set to automatic, the value will vary between 0.00 and 100.00.</p> <p>Setting range: 0.00 to 300.00</p>	7.00 [times]	<input type="radio"/>	<input type="radio"/>	<input type="radio"/>										
		<table border="1"> <thead> <tr> <th>Pr. PA08</th> <th>This parameter</th> </tr> </thead> <tbody> <tr> <td>___ 0 (2 gain adjustment mode 1 (interpolation mode))</td> <td>Automatic setting</td> </tr> <tr> <td>___ 1: (Auto tuning mode 1)</td> <td rowspan="3">Manual setting</td> </tr> <tr> <td>___ 2: (Auto tuning mode 2)</td> </tr> <tr> <td>___ 3 (Manual mode)</td> </tr> <tr> <td>___ 4: (2 gain adjustment mode 2)</td> <td></td> </tr> </tbody> </table>	Pr. PA08	This parameter	___ 0 (2 gain adjustment mode 1 (interpolation mode))	Automatic setting	___ 1: (Auto tuning mode 1)	Manual setting	___ 2: (Auto tuning mode 2)	___ 3 (Manual mode)	___ 4: (2 gain adjustment mode 2)					
Pr. PA08	This parameter															
___ 0 (2 gain adjustment mode 1 (interpolation mode))	Automatic setting															
___ 1: (Auto tuning mode 1)	Manual setting															
___ 2: (Auto tuning mode 2)																
___ 3 (Manual mode)																
___ 4: (2 gain adjustment mode 2)																
PB07 PG1 Model loop gain		<p>Set the response gain to the target position. Increasing the setting value will also increase the response level to the position command but will be liable to generate vibration and noise. For the vibration suppression control tuning mode, the setting range of [Pr. PB07] is limited. Refer to section 7.1.5 (4) for details. The setting of this parameter will be automatic or manual depending on the setting of [Pr. PA08]. Refer to the following table for details.</p> <p>Setting range: 1.0 to 2000.0</p>	15.0 [rad/s]	<input type="radio"/>	<input type="radio"/>	<input type="radio"/>										
		<table border="1"> <thead> <tr> <th>Pr. PA08</th> <th>This parameter</th> </tr> </thead> <tbody> <tr> <td>___ 0 (2 gain adjustment mode 1 (interpolation mode))</td> <td>Manual setting</td> </tr> <tr> <td>___ 1: (Auto tuning mode 1)</td> <td>Automatic setting</td> </tr> <tr> <td>___ 2: (Auto tuning mode 2)</td> <td rowspan="3">Manual setting</td> </tr> <tr> <td>___ 3 (Manual mode)</td> </tr> <tr> <td>___ 4: (2 gain adjustment mode 2)</td> </tr> </tbody> </table>	Pr. PA08	This parameter	___ 0 (2 gain adjustment mode 1 (interpolation mode))	Manual setting	___ 1: (Auto tuning mode 1)	Automatic setting	___ 2: (Auto tuning mode 2)	Manual setting	___ 3 (Manual mode)	___ 4: (2 gain adjustment mode 2)				
Pr. PA08	This parameter															
___ 0 (2 gain adjustment mode 1 (interpolation mode))	Manual setting															
___ 1: (Auto tuning mode 1)	Automatic setting															
___ 2: (Auto tuning mode 2)	Manual setting															
___ 3 (Manual mode)																
___ 4: (2 gain adjustment mode 2)																

5. PARAMETERS

No./ symbol/name	Setting digit	Function	Initial value [unit]	Network														
				ECT	EIP	PNT												
PB08 PG2 Position loop gain		<p>Set the gain of the position loop.</p> <p>Set this parameter to increase the position response to level load disturbance. Increasing the setting value will also increase the response level to the load disturbance but will be liable to generate vibration and noise.</p> <p>The setting of this parameter will be automatic or manual depending on the setting of [Pr. PA08]. Refer to the following table for details.</p> <p>Setting range: 1.0 to 2000.0</p> <table border="1" style="margin: 10px auto;"> <thead> <tr> <th>Pr. PA08</th> <th>This parameter</th> </tr> </thead> <tbody> <tr> <td>___ 0 (2 gain adjustment mode 1 (interpolation mode))</td> <td>Automatic setting</td> </tr> <tr> <td>___ 1: (Auto tuning mode 1)</td> <td></td> </tr> <tr> <td>___ 2: (Auto tuning mode 2)</td> <td></td> </tr> <tr> <td>___ 3 (Manual mode)</td> <td>Manual setting</td> </tr> <tr> <td>___ 4: (2 gain adjustment mode 2)</td> <td>Automatic setting</td> </tr> </tbody> </table>	Pr. PA08	This parameter	___ 0 (2 gain adjustment mode 1 (interpolation mode))	Automatic setting	___ 1: (Auto tuning mode 1)		___ 2: (Auto tuning mode 2)		___ 3 (Manual mode)	Manual setting	___ 4: (2 gain adjustment mode 2)	Automatic setting	37.0 [rad/s]	<input type="radio"/>	<input type="radio"/>	<input type="radio"/>
Pr. PA08	This parameter																	
___ 0 (2 gain adjustment mode 1 (interpolation mode))	Automatic setting																	
___ 1: (Auto tuning mode 1)																		
___ 2: (Auto tuning mode 2)																		
___ 3 (Manual mode)	Manual setting																	
___ 4: (2 gain adjustment mode 2)	Automatic setting																	
PB09 VG2 Speed loop gain		<p>Set the gain of the speed loop.</p> <p>Set this parameter when vibration occurs on machines of low rigidity or with large backlash. Increasing the setting value will also increase the response level but will be liable to generate vibration and noise.</p> <p>The setting of this parameter will be automatic or manual depending on the setting of [Pr. PA08]. Refer to the table of [Pr. PB08] for details.</p> <p>Setting range: 20 to 65535</p>	823 [rad/s]	<input type="radio"/>	<input type="radio"/>	<input type="radio"/>												
PB10 VIC Speed integral compensation		<p>Set the integral time constant of the speed loop.</p> <p>Decreasing the setting value will increase the response level but will be liable to generate vibration and noise.</p> <p>The setting of this parameter will be automatic or manual depending on the setting of [Pr. PA08]. Refer to the table of [Pr. PB08] for details.</p> <p>Setting range: 0.1 to 1000.0</p>	33.7 [ms]	<input type="radio"/>	<input type="radio"/>	<input type="radio"/>												
PB11 VDC Speed differential compensation		<p>Set the differential compensation.</p> <p>To enable the parameter at all times, select "Continuous PID control enabled (___ 3 ___)" of "PI-PID switching control selection" in [Pr. PB24].</p> <p>To enable it, turn on PC (Proportional control) or PID switching signal (C_PC) from upper side.</p> <p>Setting range: 0 to 1000</p>	980	<input type="radio"/>	<input type="radio"/>	<input type="radio"/>												
PB12 OVA Overshoot amount compensation		<p>Set a dynamic friction torque in percentage to the rated torque at servo motor rated speed. Or, set a percentage of dynamic friction force against the continuous thrust at linear servo motor rated speed.</p> <p>When the response level is low or when the torque/thrust is limited, the efficiency of the parameter may be lower.</p> <p>Setting range: 0 to 100</p>	0 [%]	<input type="radio"/>	<input type="radio"/>	<input type="radio"/>												
PB13 NH1 Machine resonance suppression filter 1		<p>Set the notch frequency of the machine resonance suppression filter 1.</p> <p>When "Filter tuning mode selection" is set to "Automatic setting (___ 1)" in [Pr. PB01], this parameter will be adjusted automatically by adaptive tuning.</p> <p>When "Filter tuning mode selection" is set to "Manual setting (___ 2)" in [Pr. PB01], the setting value will be enabled.</p> <p>Setting range: 10 to 4500</p>	4500 [Hz]	<input type="radio"/>	<input type="radio"/>	<input type="radio"/>												

5. PARAMETERS

No./ symbol/name	Setting digit	Function	Initial value [unit]	Network		
				ECT	EIP	PNT
PB14 NHQ1 Notch shape selection 1		Set forms of the machine resonance suppression filter 1. When "Filter tuning mode selection" is set to "Automatic setting (_ _ _ 1)" in [Pr. PB01], this parameter will be adjusted automatically by adaptive tuning. When "Filter tuning mode selection" is set to "Manual setting (_ _ _ 2)" in [Pr. PB01], the setting value will be enabled.				
	_ _ _ x	For manufacturer setting	0h	<input type="checkbox"/>	<input type="checkbox"/>	<input type="checkbox"/>
	_ _ x _	Notch depth selection 0: -40 dB 1: -14 dB 2: -8 dB 3: -4 dB	0h	<input type="checkbox"/>	<input type="checkbox"/>	<input type="checkbox"/>
	_ x _ _	Notch width selection 0: $\alpha = 2$ 1: $\alpha = 3$ 2: $\alpha = 4$ 3: $\alpha = 5$	0h	<input type="checkbox"/>	<input type="checkbox"/>	<input type="checkbox"/>
	x _ _ _	For manufacturer setting	0h	<input type="checkbox"/>	<input type="checkbox"/>	<input type="checkbox"/>
PB15 NH2 Machine resonance suppression filter 2		Set the notch frequency of the machine resonance suppression filter 2. To enable the setting value, select "Enabled (_ _ _ 1)" of "Machine resonance suppression filter 2 selection" in [Pr. PB16]. Setting range: 10 to 4500	4500 [Hz]	<input type="checkbox"/>	<input type="checkbox"/>	<input type="checkbox"/>
PB16 NHQ2 Notch shape selection 2		Set forms of the machine resonance suppression filter 2.				
	_ _ _ _ x	Machine resonance suppression filter 2 selection 0: Disabled 1: Enabled	0h	<input type="checkbox"/>	<input type="checkbox"/>	<input type="checkbox"/>
	_ _ x _	Notch depth selection 0: -40 dB 1: -14 dB 2: -8 dB 3: -4 dB	0h	<input type="checkbox"/>	<input type="checkbox"/>	<input type="checkbox"/>
	_ x _ _	Notch width selection 0: $\alpha = 2$ 1: $\alpha = 3$ 2: $\alpha = 4$ 3: $\alpha = 5$	0h	<input type="checkbox"/>	<input type="checkbox"/>	<input type="checkbox"/>
	x _ _ _	For manufacturer setting	0h	<input type="checkbox"/>	<input type="checkbox"/>	<input type="checkbox"/>

5. PARAMETERS

No./ symbol/name	Setting digit	Function	Initial value [unit]	Network																																																																						
				ECT	EIP	PNT																																																																				
PB17 NHF Shaft resonance suppression filter		<p>Set the shaft resonance suppression filter.</p> <p>Use this to suppress a low-frequency machine vibration.</p> <p>When you select "Automatic setting (___ 0)" of "Shaft resonance suppression filter selection" in [Pr. PB23], the value will be calculated automatically from the servo motor you use and load to motor inertia ratio. It will not be automatically calculated for the linear servo motor. When "Manual setting (___ 1)" is selected, the setting written to the parameter is used.</p> <p>When "Shaft resonance suppression filter selection" is set to "Disabled (___ 2)" in [Pr. PB23], the setting value of this parameter will be disabled.</p> <p>When "Machine resonance suppression filter 4 selection" is set to "Enabled (___ 1)" in [Pr. PB49], the shaft resonance suppression filter is not available.</p> <p>When "Shaft resonance suppression filter selection" is set to "Disabled (___ 2)" in [Pr. PB23], the performance may be reduced.</p>																																																																								
	__ x x	Shaft resonance suppression filter setting frequency selection Refer to table 5.5 for settings. Set the value closest to the frequency you need.	00h	<input type="radio"/>	<input type="radio"/>	<input type="radio"/>																																																																				
	_ x _ _	Notch depth selection 0: -40 dB 1: -14 dB 2: -8 dB 3: -4 dB	0h	<input type="radio"/>	<input type="radio"/>	<input type="radio"/>																																																																				
	x _ _ _	For manufacturer setting	0h	<input type="checkbox"/>	<input type="checkbox"/>	<input type="checkbox"/>																																																																				
<p>Table 5.5 Shaft resonance suppression filter setting frequency selection</p> <table border="1" style="width: 100%; border-collapse: collapse;"> <thead> <tr> <th>Setting value</th> <th>Frequency [Hz]</th> <th>Setting value</th> <th>Frequency [Hz]</th> </tr> </thead> <tbody> <tr><td>__ 0 0</td><td>Disabled</td><td>__ 1 0</td><td>562</td></tr> <tr><td>__ 0 1</td><td>Disabled</td><td>__ 1 1</td><td>529</td></tr> <tr><td>__ 0 2</td><td>4500</td><td>__ 1 2</td><td>500</td></tr> <tr><td>__ 0 3</td><td>3000</td><td>__ 1 3</td><td>473</td></tr> <tr><td>__ 0 4</td><td>2250</td><td>__ 1 4</td><td>450</td></tr> <tr><td>__ 0 5</td><td>1800</td><td>__ 1 5</td><td>428</td></tr> <tr><td>__ 0 6</td><td>1500</td><td>__ 1 6</td><td>409</td></tr> <tr><td>__ 0 7</td><td>1285</td><td>__ 1 7</td><td>391</td></tr> <tr><td>__ 0 8</td><td>1125</td><td>__ 1 8</td><td>375</td></tr> <tr><td>__ 0 9</td><td>1000</td><td>__ 1 9</td><td>360</td></tr> <tr><td>__ 0 A</td><td>900</td><td>__ 1 A</td><td>346</td></tr> <tr><td>__ 0 B</td><td>818</td><td>__ 1 B</td><td>333</td></tr> <tr><td>__ 0 C</td><td>750</td><td>__ 1 C</td><td>321</td></tr> <tr><td>__ 0 D</td><td>692</td><td>__ 1 D</td><td>310</td></tr> <tr><td>__ 0 E</td><td>642</td><td>__ 1 E</td><td>300</td></tr> <tr><td>__ 0 F</td><td>600</td><td>__ 1 F</td><td>290</td></tr> </tbody> </table>							Setting value	Frequency [Hz]	Setting value	Frequency [Hz]	__ 0 0	Disabled	__ 1 0	562	__ 0 1	Disabled	__ 1 1	529	__ 0 2	4500	__ 1 2	500	__ 0 3	3000	__ 1 3	473	__ 0 4	2250	__ 1 4	450	__ 0 5	1800	__ 1 5	428	__ 0 6	1500	__ 1 6	409	__ 0 7	1285	__ 1 7	391	__ 0 8	1125	__ 1 8	375	__ 0 9	1000	__ 1 9	360	__ 0 A	900	__ 1 A	346	__ 0 B	818	__ 1 B	333	__ 0 C	750	__ 1 C	321	__ 0 D	692	__ 1 D	310	__ 0 E	642	__ 1 E	300	__ 0 F	600	__ 1 F	290
Setting value	Frequency [Hz]	Setting value	Frequency [Hz]																																																																							
__ 0 0	Disabled	__ 1 0	562																																																																							
__ 0 1	Disabled	__ 1 1	529																																																																							
__ 0 2	4500	__ 1 2	500																																																																							
__ 0 3	3000	__ 1 3	473																																																																							
__ 0 4	2250	__ 1 4	450																																																																							
__ 0 5	1800	__ 1 5	428																																																																							
__ 0 6	1500	__ 1 6	409																																																																							
__ 0 7	1285	__ 1 7	391																																																																							
__ 0 8	1125	__ 1 8	375																																																																							
__ 0 9	1000	__ 1 9	360																																																																							
__ 0 A	900	__ 1 A	346																																																																							
__ 0 B	818	__ 1 B	333																																																																							
__ 0 C	750	__ 1 C	321																																																																							
__ 0 D	692	__ 1 D	310																																																																							
__ 0 E	642	__ 1 E	300																																																																							
__ 0 F	600	__ 1 F	290																																																																							
PB18 LPF Low-pass filter setting		<p>Set the low-pass filter.</p> <p>The following shows a relation of a required parameter to this parameter.</p> <p>Setting range: 100 to 18000</p>	3141 [rad/s]	<input type="radio"/>	<input type="radio"/>	<input type="radio"/>																																																																				
		<table border="1" style="width: 100%; border-collapse: collapse;"> <thead> <tr> <th>[Pr. PB23]</th> <th>[Pr. PB18]</th> </tr> </thead> <tbody> <tr> <td>__ 0 _ (Initial value)</td> <td>Automatic setting</td> </tr> <tr> <td>__ 1 _</td> <td>Setting value enabled</td> </tr> <tr> <td>__ 2 _</td> <td>Setting value disabled</td> </tr> </tbody> </table>	[Pr. PB23]	[Pr. PB18]	__ 0 _ (Initial value)	Automatic setting	__ 1 _	Setting value enabled	__ 2 _	Setting value disabled																																																																
[Pr. PB23]	[Pr. PB18]																																																																									
__ 0 _ (Initial value)	Automatic setting																																																																									
__ 1 _	Setting value enabled																																																																									
__ 2 _	Setting value disabled																																																																									

5. PARAMETERS

No./ symbol/name	Setting digit	Function	Initial value [unit]	Network		
				ECT	EIP	PNT
PB19 VRF11 Vibration suppression control 1 - Vibration frequency		Set the vibration frequency for vibration suppression control 1 to suppress low-frequency machine vibration. When "Vibration suppression control 1 tuning mode selection" is set to "Automatic setting (_ _ _ 1)" in [Pr. PB02], this parameter will be set automatically. When "Manual setting (_ _ _ 2)" is selected, the setting written to the parameter is used. The setting range of this parameter varies, depending on the value in [Pr. PB07]. If a value out of the range is set, the vibration suppression control will be disabled. Refer to section 7.1.5 for details. Setting range: 0.1 to 300.0	100.0 [Hz]	<input type="radio"/>	<input type="radio"/>	<input type="radio"/>
PB20 VRF12 Vibration suppression control 1 - Resonance frequency		Set the resonance frequency for vibration suppression control 1 to suppress low-frequency machine vibration. When "Vibration suppression control 1 tuning mode selection" is set to "Automatic setting (_ _ _ 1)" in [Pr. PB02], this parameter will be set automatically. When "Manual setting (_ _ _ 2)" is selected, the setting written to the parameter is used. The setting range of this parameter varies, depending on the value in [Pr. PB07]. If a value out of the range is set, the vibration suppression control will be disabled. Refer to section 7.1.5 for details. Setting range: 0.1 to 300.0	100.0 [Hz]	<input type="radio"/>	<input type="radio"/>	<input type="radio"/>
PB21 VRF13 Vibration suppression control 1 - Vibration frequency damping		Set a damping of the vibration frequency for vibration suppression control 1 to suppress low-frequency machine vibration. When "Vibration suppression control 1 tuning mode selection" is set to "Automatic setting (_ _ _ 1)" in [Pr. PB02], this parameter will be set automatically. When "Manual setting (_ _ _ 2)" is selected, the setting written to the parameter is used. Refer to section 7.1.5 for details. Setting range: 0.00 to 0.30	0.00	<input type="radio"/>	<input type="radio"/>	<input type="radio"/>
PB22 VRF14 Vibration suppression control 1 - Resonance frequency damping		Set a damping of the resonance frequency for vibration suppression control 1 to suppress low-frequency machine vibration. When "Vibration suppression control 1 tuning mode selection" is set to "Automatic setting (_ _ _ 1)" in [Pr. PB02], this parameter will be set automatically. When "Manual setting (_ _ _ 2)" is selected, the setting written to the parameter is used. Refer to section 7.1.5 for details. Setting range: 0.00 to 0.30	0.00	<input type="radio"/>	<input type="radio"/>	<input type="radio"/>
PB23 VFBF Low-pass filter selection	_ _ _ x	Shaft resonance suppression filter selection Select the shaft resonance suppression filter. 0: Automatic setting 1: Manual setting 2: Disabled When you select "Enabled (_ _ _ 1)" of "Machine resonance suppression filter 4 selection" in [Pr. PB49], the shaft resonance suppression filter is not available.	0h	<input type="radio"/>	<input type="radio"/>	<input type="radio"/>
	_ _ x _	Low-pass filter selection Select the low-pass filter. 0: Automatic setting 1: Manual setting 2: Disabled	0h	<input type="radio"/>	<input type="radio"/>	<input type="radio"/>
	_ x _ _	For manufacturer setting	0h	<input type="checkbox"/>	<input type="checkbox"/>	<input type="checkbox"/>
	x _ _ _		0h	<input type="checkbox"/>	<input type="checkbox"/>	<input type="checkbox"/>

5. PARAMETERS

No./ symbol/name	Setting digit	Function	Initial value [unit]	Network		
				ECT	EIP	PNT
PB24 *MVS Slight vibration suppression control	__ _ x	Slight vibration suppression control selection Select the slight vibration suppression control. 0: Disabled 1: Enabled To enable the slight vibration suppression control, set "Gain adjustment mode selection" to "Manual mode (_ _ _ 3)" in [Pr. PA08]. Slight vibration suppression control selection cannot be used in the velocity mode.	0h	<input type="radio"/>	<input type="radio"/>	<input type="radio"/>
	_ _ x _	PI-PID switching control selection 0: PI control enabled (Switching is enabled by PID switching signal from upper side (C_PC) and Input device PC (Proportional control).) 3: Continuous PID control enabled If the servo motor at a stop is rotated even for a pulse due to any external factor, it generates torque to compensate for a position shift. When the servo motor shaft is to be locked mechanically after positioning completion (stop), enabling PID control and completing positioning simultaneously will suppress the unnecessary torque generated to compensate for a position shift.	0h	<input type="radio"/>	<input type="radio"/>	<input type="radio"/>
	_ x _ _	For manufacturer setting	0h	<input type="checkbox"/>	<input type="checkbox"/>	<input type="checkbox"/>
	x _ _ _		0h	<input type="checkbox"/>	<input type="checkbox"/>	<input type="checkbox"/>
PB25 *BOP1 Function selection B-1	__ _ x	Model adaptive control selection 0: Enabled (model adaptive control) 2: Disabled (PID control) Refer to section 7.5 for details.	0h	<input type="radio"/>	<input type="radio"/>	<input type="radio"/>
	_ _ x _	For manufacturer setting	0h	<input type="checkbox"/>	<input type="checkbox"/>	<input type="checkbox"/>
	_ x _ _		0h	<input type="checkbox"/>	<input type="checkbox"/>	<input type="checkbox"/>
	x _ _ _		0h	<input type="checkbox"/>	<input type="checkbox"/>	<input type="checkbox"/>
PB26 *CDP Gain switching function	Select a gain switching condition. Set conditions to enable the gain switching values set in [Pr. PB29] to [Pr. PB36] and [Pr. PB56] to [Pr. PB60].					
	__ _ x	Gain switching selection 0: Disabled 1: Switching is enabled by control command from upper side (C_CDP) and Input device CDP (Gain switching). 2: Command frequency 3: Droop pulses 4: Servo motor speed	0h	<input type="radio"/>	<input type="radio"/>	<input type="radio"/>
	_ _ x _	Gain switching condition selection 0: Gain after switching is enabled with gain switching condition or more 1: Gain after switching is enabled with gain switching condition or less	0h	<input type="radio"/>	<input type="radio"/>	<input type="radio"/>
	_ x _ _	Gain switching time constant disabling condition selection 0: Switching time constant enabled 1: Switching time constant disabled 2: Return time constant disabled Refer to section 7.2.4 for details.	0h	<input type="radio"/>	<input type="radio"/>	<input type="radio"/>
	x _ _ _	For manufacturer setting	0h	<input type="checkbox"/>	<input type="checkbox"/>	<input type="checkbox"/>
PB27 CDL Gain switching condition		This is used to set the value of gain switching (command frequency, droop pulses, and servo motor speed) selected in [Pr. PB26]. The set value unit differs depending on the switching condition item. (Refer to section 7.2.3.) The unit "r/min" will be "mm/s" for linear servo motors. Setting range: 0 to 65535	10 [kpulse/s]/ [pulse]/ [r/min]	<input type="radio"/>	<input type="radio"/>	<input type="radio"/>
PB28 CDT Gain switching time constant		Set the time constant until the gains switch in response to the conditions set in [Pr. PB26] and [Pr. PB27]. Setting range: 0 to 100	1 [ms]	<input type="radio"/>	<input type="radio"/>	<input type="radio"/>

5. PARAMETERS

No./ symbol/name	Setting digit	Function	Initial value [unit]	Network		
				ECT	EIP	PNT
PB29 GD2B Load to motor inertia ratio		Set a load to motor inertia ratio for when gain switching is enabled. This parameter is enabled only when "Gain adjustment mode selection" is set to "Manual mode (_ _ _ 3)" in [Pr. PA08]. Setting range: 0.00 to 300.00	7.00 [times]	<input type="radio"/>	<input type="radio"/>	<input type="radio"/>
PB30 PG2B Position loop gain after gain switching		Set the position loop gain for when the gain switching is enabled. When a value less than 1.0 rad/s is set, the value will be the same as that of [Pr. PB08]. This parameter is enabled only when "Gain adjustment mode selection" is set to "Manual mode (_ _ _ 3)" in [Pr. PA08]. Setting range: 0.0 to 2000.0	0.0 [rad/s]	<input type="radio"/>	<input type="radio"/>	<input type="radio"/>
PB31 VG2B Speed loop gain after gain switching		Set the speed loop gain for when the gain switching is enabled. When a value less than 20 rad/s is set, the value will be the same as that of [Pr. PB09]. This parameter is enabled only when "Gain adjustment mode selection" is set to "Manual mode (_ _ _ 3)" in [Pr. PA08]. Setting range: 0 to 65535	0 [rad/s]	<input type="radio"/>	<input type="radio"/>	<input type="radio"/>
PB32 VICB Speed integral compensation after gain switching		Set the speed integral compensation for when the gain switching is enabled. When a value less than 0.1 ms is set, the value will be the same as that of [Pr. PB10]. This parameter is enabled only when "Gain adjustment mode selection" is set to "Manual mode (_ _ _ 3)" in [Pr. PA08]. Setting range: 0.0 to 5000.0	0.0 [ms]	<input type="radio"/>	<input type="radio"/>	<input type="radio"/>
PB33 VRF11B Vibration suppression control 1 - Vibration frequency after gain switching		Set the vibration frequency of the vibration suppression control 1 for when the gain switching is enabled. When a value less than 0.1 Hz is set, the value will be the same as that of [Pr. PB19]. This parameter is enabled only when the following conditions are fulfilled. <ul style="list-style-type: none"> ▪ "Gain adjustment mode selection" is set to "Manual mode (_ _ _ 3)" in [Pr. PA08]. ▪ "Vibration suppression control 1 tuning mode selection" is set to "Manual setting (_ _ _ 2)" in [Pr. PB02]. ▪ "Gain switching selection" is set to "Switching is enabled by control command from upper side (C_CDP) and Input device CDP (Gain switching). (_ _ _ 1)" in [Pr. PB26]. Switching during driving may cause a shock. Be sure to switch them after the servo motor stops. Setting range: 0.0 to 300.0	0.0 [Hz]	<input type="radio"/>	<input type="radio"/>	<input type="radio"/>
PB34 VRF12B Vibration suppression control 1 - Resonance frequency after gain switching		Set the resonance frequency for vibration suppression control 1 for when the gain switching is enabled. When a value less than 0.1 Hz is set, the value will be the same as that of [Pr. PB20]. This parameter will be enabled only when the following conditions are fulfilled. <ul style="list-style-type: none"> ▪ "Gain adjustment mode selection" is set to "Manual mode (_ _ _ 3)" in [Pr. PA08]. ▪ "Vibration suppression control 1 tuning mode selection" is set to "Manual setting (_ _ _ 2)" in [Pr. PB02]. ▪ "Gain switching selection" is set to "Switching is enabled by control command from upper side (C_CDP) and Input device CDP (Gain switching). (_ _ _ 1)" in [Pr. PB26]. Switching during driving may cause a shock. Be sure to switch them after the servo motor stops. Setting range: 0.0 to 300.0	0.0 [Hz]	<input type="radio"/>	<input type="radio"/>	<input type="radio"/>

5. PARAMETERS

No./ symbol/name	Setting digit	Function	Initial value [unit]	Network		
				ECT	EIP	PNT
PB35 VRF13B Vibration suppression control 1 - Vibration frequency damping after gain switching		<p>Set a damping of the vibration frequency for vibration suppression control 1 when the gain switching is enabled.</p> <p>This parameter will be enabled only when the following conditions are fulfilled.</p> <ul style="list-style-type: none"> • "Gain adjustment mode selection" is set to "Manual mode (_ _ _ 3)" in [Pr. PA08]. • "Vibration suppression control 1 tuning mode selection" is set to "Manual setting (_ _ _ 2)" in [Pr. PB02]. • "Gain switching selection" is set to "Switching is enabled by control command from upper side (C_CDP) and Input device CDP (Gain switching). (_ _ _ 1)" in [Pr. PB26]. <p>Switching during driving may cause a shock. Be sure to switch them after the servo motor stops.</p> <p>Setting range: 0.00 to 0.30</p>	0.00	<input type="radio"/>	<input type="radio"/>	<input type="radio"/>
PB36 VRF14B Vibration suppression control 1 - Resonance frequency damping after gain switching		<p>Set a damping of the resonance frequency for vibration suppression control 1 when the gain switching is enabled.</p> <p>This parameter will be enabled only when the following conditions are fulfilled.</p> <ul style="list-style-type: none"> • "Gain adjustment mode selection" is set to "Manual mode (_ _ _ 3)" in [Pr. PA08]. • "Vibration suppression control 1 tuning mode selection" is set to "Manual setting (_ _ _ 2)" in [Pr. PB02]. • "Gain switching selection" is set to "Switching is enabled by control command from upper side (C_CDP) and Input device CDP (Gain switching). (_ _ _ 1)" in [Pr. PB26]. <p>Switching during driving may cause a shock. Be sure to switch them after the servo motor stops.</p> <p>Setting range: 0.00 to 0.30</p>	0.00	<input type="radio"/>	<input type="radio"/>	<input type="radio"/>

5. PARAMETERS

No./ symbol/name	Setting digit	Function	Initial value [unit]	Network		
				ECT	EIP	PNT
PB45	Set the command notch filter.					
CNHF	__ x x	Command notch filter setting frequency selection Refer to table 5.6 for the relation of setting values to frequency.	00h	<input type="radio"/>	<input type="radio"/>	<input type="radio"/>
Command notch filter	_ x _ _	Notch depth selection Refer to table 5.7 for details.	0h	<input type="radio"/>	<input type="radio"/>	<input type="radio"/>
	x _ _ _	For manufacturer setting	0h			

Table 5.6 Command notch filter setting frequency selection

Setting value	Frequency [Hz]	Setting value	Frequency [Hz]	Setting value	Frequency [Hz]
__ 0 0	Disabled	__ 2 0	70	__ 4 0	17.6
__ 0 1	2250	__ 2 1	66	__ 4 1	16.5
__ 0 2	1125	__ 2 2	62	__ 4 2	15.6
__ 0 3	750	__ 2 3	59	__ 4 3	14.8
__ 0 4	562	__ 2 4	56	__ 4 4	14.1
__ 0 5	450	__ 2 5	53	__ 4 5	13.4
__ 0 6	375	__ 2 6	51	__ 4 6	12.8
__ 0 7	321	__ 2 7	48	__ 4 7	12.2
__ 0 8	281	__ 2 8	46	__ 4 8	11.7
__ 0 9	250	__ 2 9	45	__ 4 9	11.3
__ 0 A	225	__ 2 A	43	__ 4 A	10.8
__ 0 B	204	__ 2 B	41	__ 4 B	10.4
__ 0 C	187	__ 2 C	40	__ 4 C	10
__ 0 D	173	__ 2 D	38	__ 4 D	9.7
__ 0 E	160	__ 2 E	37	__ 4 E	9.4
__ 0 F	150	__ 2 F	36	__ 4 F	9.1
__ 1 0	140	__ 3 0	35.2	__ 5 0	8.8
__ 1 1	132	__ 3 1	33.1	__ 5 1	8.3
__ 1 2	125	__ 3 2	31.3	__ 5 2	7.8
__ 1 3	118	__ 3 3	29.6	__ 5 3	7.4
__ 1 4	112	__ 3 4	28.1	__ 5 4	7.0
__ 1 5	107	__ 3 5	26.8	__ 5 5	6.7
__ 1 6	102	__ 3 6	25.6	__ 5 6	6.4
__ 1 7	97	__ 3 7	24.5	__ 5 7	6.1
__ 1 8	93	__ 3 8	23.4	__ 5 8	5.9
__ 1 9	90	__ 3 9	22.5	__ 5 9	5.6
__ 1 A	86	__ 3 A	21.6	__ 5 A	5.4
__ 1 B	83	__ 3 B	20.8	__ 5 B	5.2
__ 1 C	80	__ 3 C	20.1	__ 5 C	5.0
__ 1 D	77	__ 3 D	19.4	__ 5 D	4.9
__ 1 E	75	__ 3 E	18.8	__ 5 E	4.7
__ 1 F	72	__ 3 F	18.2	__ 5 F	4.5

Table 5.7 Notch depth selection

Setting value	Depth [dB]	Setting value	Depth [dB]
_ 0 _ _	-40.0	_ 8 _ _	-6.0
_ 1 _ _	-24.1	_ 9 _ _	-5.0
_ 2 _ _	-18.1	_ A _ _	-4.1
_ 3 _ _	-14.5	_ B _ _	-3.3
_ 4 _ _	-12.0	_ C _ _	-2.5
_ 5 _ _	-10.1	_ D _ _	-1.8
_ 6 _ _	-8.5	_ E _ _	-1.2
_ 7 _ _	-7.2	_ F _ _	-0.6

5. PARAMETERS

No./ symbol/name	Setting digit	Function	Initial value [unit]	Network		
				ECT	EIP	PNT
PB46 NH3 Machine resonance suppression filter 3		Set the notch frequency of the machine resonance suppression filter 3. To enable the setting value, set "Machine resonance suppression filter 3 selection" to "Enabled (_ _ _ 1)" in [Pr. PB47]. Setting range: 10 to 4500	4500 [Hz]	<input type="radio"/>	<input type="radio"/>	<input type="radio"/>
PB47 NHQ3 Notch shape selection 3		Set forms of the machine resonance suppression filter 3.				
	___ x	Machine resonance suppression filter 3 selection 0: Disabled 1: Enabled	0h	<input type="radio"/>	<input type="radio"/>	<input type="radio"/>
	_ _ x _	Notch depth selection 0: -40 dB 1: -14 dB 2: -8 dB 3: -4 dB	0h	<input type="radio"/>	<input type="radio"/>	<input type="radio"/>
	_ x _ _	Notch width selection 0: $\alpha = 2$ 1: $\alpha = 3$ 2: $\alpha = 4$ 3: $\alpha = 5$	0h	<input type="radio"/>	<input type="radio"/>	<input type="radio"/>
	x _ _ _	For manufacturer setting	0h	<input type="radio"/>	<input type="radio"/>	<input type="radio"/>
PB48 NH4 Machine resonance suppression filter 4		Set the notch frequency of the machine resonance suppression filter 4. To enable the setting value, set "Machine resonance suppression filter 4 selection" to "Enabled (_ _ _ 1)" in [Pr. PB49]. Setting range: 10 to 4500	4500 [Hz]	<input type="radio"/>	<input type="radio"/>	<input type="radio"/>
PB49 NHQ4 Notch shape selection 4		Set forms of the machine resonance suppression filter 4.				
	___ x	Machine resonance suppression filter 4 selection 0: Disabled 1: Enabled When "Enabled" is set, [Pr. PB17 Shaft resonance suppression filter] is not available.	0h	<input type="radio"/>	<input type="radio"/>	<input type="radio"/>
	_ _ x _	Notch depth selection 0: -40 dB 1: -14 dB 2: -8 dB 3: -4 dB	0h	<input type="radio"/>	<input type="radio"/>	<input type="radio"/>
	_ x _ _	Notch width selection 0: $\alpha = 2$ 1: $\alpha = 3$ 2: $\alpha = 4$ 3: $\alpha = 5$	0h	<input type="radio"/>	<input type="radio"/>	<input type="radio"/>
	x _ _ _	For manufacturer setting	0h	<input type="radio"/>	<input type="radio"/>	<input type="radio"/>
PB50 NH5 Machine resonance suppression filter 5		Set the notch frequency of the machine resonance suppression filter 5. To enable the setting value, set "Machine resonance suppression filter 5 selection" to "Enabled (_ _ _ 1)" in [Pr. PB51]. Setting range: 10 to 4500	4500 [Hz]	<input type="radio"/>	<input type="radio"/>	<input type="radio"/>

5. PARAMETERS

No./ symbol/name	Setting digit	Function	Initial value [unit]	Network		
				ECT	EIP	PNT
PB51 NHQ5 Notch shape selection 5	Set forms of the machine resonance suppression filter 5. When "Robust filter selection" is set to "Enabled (_ _ _ 1)" in [Pr. PE41], the machine resonance suppression filter 5 is not available.					
	___ x	Machine resonance suppression filter 5 selection 0: Disabled 1: Enabled	0h	<input type="radio"/>	<input type="radio"/>	<input type="radio"/>
	__ x _	Notch depth selection 0: -40 dB 1: -14 dB 2: -8 dB 3: -4 dB	0h	<input type="radio"/>	<input type="radio"/>	<input type="radio"/>
	_ x ___	Notch width selection 0: $\alpha = 2$ 1: $\alpha = 3$ 2: $\alpha = 4$ 3: $\alpha = 5$	0h	<input type="radio"/>	<input type="radio"/>	<input type="radio"/>
	x ___	For manufacturer setting	0h	<input type="checkbox"/>	<input type="checkbox"/>	<input type="checkbox"/>
PB52 VRF21 Vibration suppression control 2 - Vibration frequency		Set the vibration frequency for vibration suppression control 2 to suppress low-frequency machine vibration. When "Vibration suppression control 2 tuning mode selection" is set to "Automatic setting (_ _ 1 _)" in [Pr. PB02], this parameter will be set automatically. When "Manual setting (_ _ 2 _)" is selected, the setting written to the parameter is used. The setting range of this parameter varies, depending on the value in [Pr. PB07]. If a value out of the range is set, the vibration suppression control will be disabled. Refer to section 7.1.5 for details. To enable the setting value, set "Vibration suppression mode selection" to "3 inertia mode (_ _ _ 1)" in [Pr. PA24]. Setting range: 0.1 to 300.0	100.0 [Hz]	<input type="radio"/>	<input type="radio"/>	<input type="radio"/>
PB53 VRF22 Vibration suppression control 2 - Resonance frequency		Set the resonance frequency for vibration suppression control 2 to suppress low-frequency machine vibration. When "Vibration suppression control 2 tuning mode selection" is set to "Automatic setting (_ _ 1 _)" in [Pr. PB02], this parameter will be set automatically. When "Manual setting (_ _ 2 _)" is selected, the setting written to the parameter is used. The setting range of this parameter varies, depending on the value in [Pr. PB07]. If a value out of the range is set, the vibration suppression control will be disabled. Refer to section 7.1.5 for details. To enable the setting value, set "Vibration suppression mode selection" to "3 inertia mode (_ _ _ 1)" in [Pr. PA24]. Setting range: 0.1 to 300.0	100.0 [Hz]	<input type="radio"/>	<input type="radio"/>	<input type="radio"/>
PB54 VRF23 Vibration suppression control 2 - Vibration frequency damping		Set a damping of the vibration frequency for vibration suppression control 2 to suppress low-frequency machine vibration. When "Vibration suppression control 2 tuning mode selection" is set to "Automatic setting (_ _ 1 _)" in [Pr. PB02], this parameter will be set automatically. When "Manual setting (_ _ 2 _)" is selected, the setting written to the parameter is used. Refer to section 7.1.5 for details. To enable the setting value, set "Vibration suppression mode selection" to "3 inertia mode (_ _ _ 1)" in [Pr. PA24]. Setting range: 0.00 to 0.30	0.00	<input type="radio"/>	<input type="radio"/>	<input type="radio"/>
PB55 VRF24 Vibration suppression control 2 - Resonance frequency damping		Set a damping of the resonance frequency for vibration suppression control 2 to suppress low-frequency machine vibration. When "Vibration suppression control 2 tuning mode selection" is set to "Automatic setting (_ _ 1 _)" in [Pr. PB02], this parameter will be set automatically. When "Manual setting (_ _ 2 _)" is selected, the setting written to the parameter is used. Refer to section 7.1.5 for details. To enable the setting value, set "Vibration suppression mode selection" to "3 inertia mode (_ _ _ 1)" in [Pr. PA24]. Setting range: 0.00 to 0.30	0.00	<input type="radio"/>	<input type="radio"/>	<input type="radio"/>

5. PARAMETERS

No./ symbol/name	Setting digit	Function	Initial value [unit]	Network		
				ECT	EIP	PNT
PB56 VRF21B Vibration suppression control 2 - Vibration frequency after gain switching		<p>Set the vibration frequency for vibration suppression control 2 for when the gain switching is enabled. When a value less than 0.1 Hz is set, the value will be the same as that of [Pr. PB52]. This parameter will be enabled only when the following conditions are fulfilled.</p> <ul style="list-style-type: none"> • "Gain adjustment mode selection" is set to "Manual mode (_ _ _ 3)" in [Pr. PA08]. • "Vibration suppression mode selection" is set to "3 inertia mode (_ _ _ 1)" in [Pr. PA24]. • "Vibration suppression control 2 tuning mode selection" is set to "Manual setting (_ _ 2 _)" in [Pr. PB02]. • "Gain switching selection" is set to "Switching is enabled by control command from upper side (C_CDP) and Input device CDP (Gain switching). (_ _ _ 1)" in [Pr. PB26]. <p>Switching during driving may cause a shock. Be sure to switch them after the servo motor stops.</p> <p>Setting range: 0.0 to 300.0</p>	0.0 [Hz]	<input type="radio"/>	<input type="radio"/>	<input type="radio"/>
PB57 VRF22B Vibration suppression control 2 - Resonance frequency after gain switching		<p>Set the resonance frequency for vibration suppression control 2 for when the gain switching is enabled. When a value less than 0.1 Hz is set, the value will be the same as that of [Pr. PB53]. This parameter will be enabled only when the following conditions are fulfilled.</p> <ul style="list-style-type: none"> • "Gain adjustment mode selection" is set to "Manual mode (_ _ _ 3)" in [Pr. PA08]. • "Vibration suppression mode selection" is set to "3 inertia mode (_ _ _ 1)" in [Pr. PA24]. • "Vibration suppression control 2 tuning mode selection" is set to "Manual setting (_ _ 2 _)" in [Pr. PB02]. • "Gain switching selection" is set to "Switching is enabled by control command from upper side (C_CDP) and Input device CDP (Gain switching). (_ _ _ 1)" in [Pr. PB26]. <p>Switching during driving may cause a shock. Be sure to switch them after the servo motor stops.</p> <p>Setting range: 0.0 to 300.0</p>	0.0 [Hz]	<input type="radio"/>	<input type="radio"/>	<input type="radio"/>
PB58 VRF23B Vibration suppression control 2 - Vibration frequency damping after gain switching		<p>Set a damping of the vibration frequency for vibration suppression control 2 when the gain switching is enabled. This parameter will be enabled only when the following conditions are fulfilled.</p> <ul style="list-style-type: none"> • "Gain adjustment mode selection" is set to "Manual mode (_ _ _ 3)" in [Pr. PA08]. • "Vibration suppression mode selection" is set to "3 inertia mode (_ _ _ 1)" in [Pr. PA24]. • "Vibration suppression control 2 tuning mode selection" is set to "Manual setting (_ _ 2 _)" in [Pr. PB02]. • "Gain switching selection" is set to "Switching is enabled by control command from upper side (C_CDP) and Input device CDP (Gain switching). (_ _ _ 1)" in [Pr. PB26]. <p>Switching during driving may cause a shock. Be sure to switch them after the servo motor stops.</p> <p>Setting range: 0.00 to 0.30</p>	0.00	<input type="radio"/>	<input type="radio"/>	<input type="radio"/>
PB59 VRF24B Vibration suppression control 2 - Resonance		<p>Set a damping of the resonance frequency for vibration suppression control 2 when the gain switching is enabled. This parameter will be enabled only when the following conditions are fulfilled.</p> <ul style="list-style-type: none"> • "Gain adjustment mode selection" is set to "Manual mode (_ _ _ 3)" in [Pr. PA08]. 	0.00	<input type="radio"/>	<input type="radio"/>	<input type="radio"/>

5. PARAMETERS







frequency damping after gain switching		<ul style="list-style-type: none"> "Vibration suppression mode selection" is set to "3 inertia mode (_ _ _ 1)" in [Pr. PA24]. "Vibration suppression control 2 tuning mode selection" is set to "Manual setting (_ _ 2 _)" in [Pr. PB02]. "Gain switching selection" is set to "Switching is enabled by control command from upper side (C_CDP) and Input device CDP (Gain switching). (_ _ _ 1)" in [Pr. PB26]. <p>Switching during driving may cause a shock. Be sure to switch them after the servo motor stops.</p> <p>Setting range: 0.00 to 0.30</p>				
--	--	--	--	--	--	--

No./symbol/name	Setting digit	Function	Initial value [unit]	Network		
				ECT	EIP	PNT
PB60 PG1B Model loop gain after gain switching		<p>Set the model loop gain for when the gain switching is enabled. When a value less than 1.0 rad/s is set, the value will be the same as that of [Pr. PB07].</p> <p>This parameter will be enabled only when the following conditions are fulfilled.</p> <ul style="list-style-type: none"> "Gain adjustment mode selection" is set to "Manual mode (_ _ _ 3)" in [Pr. PA08]. "Gain switching selection" is set to "Switching is enabled by control command from upper side (C_CDP) and Input device CDP (Gain switching). (_ _ _ 1)" in [Pr. PB26]. <p>Switching during driving may cause a shock. Be sure to switch them after the servo motor stops.</p> <p>Setting range: 0.0 to 2000.0</p>	0.0 [rad/s]	<input type="radio"/>	<input type="radio"/>	<input type="radio"/>

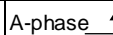
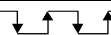
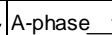
5.2.3 Extension setting parameters ([Pr. PC_ _])

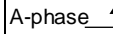
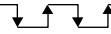
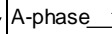
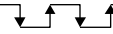
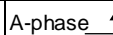
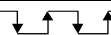
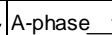
No./symbol/name	Setting digit	Function	Initial value [unit]	Network		
				ECT	EIP	PNT
PC01 ERZ Error excessive alarm level		<p>Set an error excessive alarm level. The setting unit can be changed with "Error excessive alarm/error excessive warning level unit selection" in [Pr. PC06].</p> <p>Set this per rev. for rotary servo motors and direct drive motors. When "0" is set, 3 rev will be applied. Setting over 200 rev will be clamped to 200 rev.</p> <p>Setting range: 0 to 1000</p>	0 [rev]	<input type="radio"/>	<input type="radio"/>	<input type="radio"/>
PC02 MBR Electromagnetic brake sequence output		<p>Set the delay time from when MBR (Electromagnetic brake interlock) turns off until when the base drive circuit is shut-off. For the timing chart of when the servo motor with an electromagnetic brake is used, refer to section 3.9.2.</p> <p>Setting range: 0 to 1000</p>	0 [ms]	<input type="radio"/>	<input type="radio"/>	<input type="radio"/>

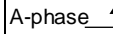
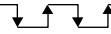
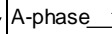
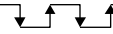
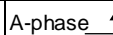
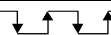
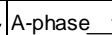
5. PARAMETERS

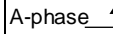
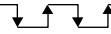
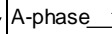
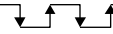
No./ symbol/name	Setting digit	Function	Initial value [unit]	Network													
				ECT	EIP	PNT											
PC03 *ENRS Encoder output pulse selection	___x	Encoder output pulse phase selection Select an encoder pulse direction. 0: Increasing A-phase 90° in CCW or positive direction 1: Increasing A-phase 90° in CW or negative direction <table border="1" style="margin-left: auto; margin-right: auto;"> <thead> <tr> <th rowspan="2">Setting value</th> <th colspan="2">Servo motor rotation direction</th> </tr> <tr> <th>CCW or positive direction</th> <th>CW or negative direction</th> </tr> </thead> <tbody> <tr> <td>0</td> <td>A-phase  B-phase </td> <td>A-phase  B-phase </td> </tr> <tr> <td>1</td> <td>A-phase  B-phase </td> <td>A-phase  B-phase </td> </tr> </tbody> </table>	Setting value	Servo motor rotation direction		CCW or positive direction	CW or negative direction	0	A-phase  B-phase 	A-phase  B-phase 	1	A-phase  B-phase 	A-phase  B-phase 	0h	<input type="radio"/>	<input type="radio"/>	<input type="radio"/>
	Setting value	Servo motor rotation direction															
		CCW or positive direction	CW or negative direction														
	0	A-phase  B-phase 	A-phase  B-phase 														
1	A-phase  B-phase 	A-phase  B-phase 															
__x_	Encoder output pulse setting selection 0: Output pulse setting 1: Division ratio setting 3: A-phase/B-phase pulse electronic gear setting 4: A/B-phase pulse through output setting Refer to app. 12 for details.	0h	<input type="radio"/>	<input type="radio"/>	<input type="radio"/>												
_x__	Selection of the encoders for encoder output pulse Do not change this value.	0h	<input type="radio"/>	<input type="radio"/>	<input type="radio"/>												
x___	For manufacturer setting	0h	/	/	/												
PC04 **COP1 Function selection C-1	___x	For manufacturer setting	0h	/	/	/											
	__x_		0h	/	/	/											
	_x__		0h	/	/	/											
	x___	Encoder cable communication method selection Do not change this value.	0h	<input type="radio"/>	<input type="radio"/>	<input type="radio"/>											

5. PARAMETERS

No./ symbol/name	Setting digit	Function	Initial value [unit]	Network		
				ECT	EIP	PNT
PC05 **COP2 Function selection C-2	___x	Motor-less operation selection Set the motor-less operation. 0: Disabled 1: Enabled	0h	<input type="radio"/>	<input type="radio"/>	<input type="radio"/>
	__x_	For manufacturer setting	0h	<input type="checkbox"/>	<input type="checkbox"/>	<input type="checkbox"/>
	_x__		0h	<input type="checkbox"/>	<input type="checkbox"/>	<input type="checkbox"/>
	x___		0h	<input type="checkbox"/>	<input type="checkbox"/>	<input type="checkbox"/>
PC06 *COP3 Function selection C-3	___x	In-position range unit selection Select a unit of in-position range. 0: Command input pulse unit 1: Servo motor encoder pulse unit	0h	<input type="radio"/>	<input type="radio"/>	<input type="radio"/>
	__x_	For manufacturer setting	0h	<input type="checkbox"/>	<input type="checkbox"/>	<input type="checkbox"/>
	_x__		0h	<input type="checkbox"/>	<input type="checkbox"/>	<input type="checkbox"/>
	x___	Error excessive alarm/error excessive warning level unit selection Select units for error excessive alarm level setting with [Pr. PC01] and for error excessive warning level setting with [Pr. PC38]. 0: Per 1 rev or 1 mm 1: Per 0.1 rev or 0.1 mm 2: Per 0.01 rev or 0.01 mm 3: Per 0.001 rev or 0.001 mm	0h	<input type="radio"/>	<input type="radio"/>	<input type="radio"/>
PC07 ZSP Zero speed		Set an output range of ZSP (Zero speed detection). ZSP (Zero speed detection) has hysteresis of 20 r/min or 20 mm/s. Setting range: 0 to 10000	50 [r/min]/ [mm/s]	<input type="radio"/>	<input type="radio"/>	<input type="radio"/>
PC08 OSL Overspeed alarm detection level		Set an overspeed alarm detection level. When you set a value more than "servo motor maximum speed × 120%", the set value will be clamped. When you set "0", the value of "servo motor maximum speed × 120%" will be set. Setting range: 0 to 20000	0 [r/min]/ [mm/s]	<input type="radio"/>	<input type="radio"/>	<input type="radio"/>

5. PARAMETERS

No./ symbol/name	Setting digit	Function	Initial value [unit]	Network																																																																		
				ECT	EIP	PNT																																																																
PC09 MOD1 Analog monitor 1 output	__ x x	Analog monitor 1 output selection Select a signal to output to MO1 (Analog monitor 1). Refer to app. 8.3 for detection point of output selection. Refer to table 5.8 for settings.	00h	<input type="radio"/>	<input type="radio"/>	<input type="radio"/>																																																																
	_ x _ _	For manufacturer setting	0h	<input type="checkbox"/>	<input type="checkbox"/>	<input type="checkbox"/>																																																																
	x _ _ _		0h	<input type="checkbox"/>	<input type="checkbox"/>	<input type="checkbox"/>																																																																
<p>Table 5.8 Analog monitor setting value</p> <table border="1"> <thead> <tr> <th rowspan="2">Setting value</th> <th rowspan="2">Item</th> <th>Operation mode</th> </tr> <tr> <th>Standard</th> </tr> </thead> <tbody> <tr> <td>__ 0 0</td> <td>Servo motor speed (± 8 V/max. speed)</td> <td><input type="radio"/></td> </tr> <tr> <td>__ 0 1</td> <td>Torque (± 8 V/max. torque or max. thrust) (Note 3)</td> <td><input type="radio"/></td> </tr> <tr> <td>__ 0 2</td> <td>Servo motor speed (+8 V/max. speed)</td> <td><input type="radio"/></td> </tr> <tr> <td>__ 0 3</td> <td>Torque (+8 V/max. torque or max. thrust) (Note 3)</td> <td><input type="radio"/></td> </tr> <tr> <td>__ 0 4</td> <td>Current command (± 8 V/max. current command)</td> <td><input type="radio"/></td> </tr> <tr> <td>__ 0 5</td> <td>Speed command (± 8 V/max. speed)</td> <td><input type="radio"/></td> </tr> <tr> <td>__ 0 6</td> <td>Servo motor-side droop pulses (± 10 V/100 pulses) (Note 2)</td> <td><input type="radio"/></td> </tr> <tr> <td>__ 0 7</td> <td>Servo motor-side droop pulses (± 10 V/1000 pulses) (Note 2)</td> <td><input type="radio"/></td> </tr> <tr> <td>__ 0 8</td> <td>Servo motor-side droop pulses (± 10 V/10000 pulses) (Note 2)</td> <td><input type="radio"/></td> </tr> <tr> <td>__ 0 9</td> <td>Servo motor-side droop pulses (± 10 V/100000 pulses) (Note 2)</td> <td><input type="radio"/></td> </tr> <tr> <td>__ 0 D</td> <td>Bus voltage (200 V class and 100 V class: +8 V/400 V, 400 V class: +8 V/800 V)</td> <td><input type="radio"/></td> </tr> <tr> <td>__ 0 E</td> <td>Speed command 2 (± 8 V/max. speed)</td> <td><input type="radio"/></td> </tr> <tr> <td>__ 1 0</td> <td>Load-side droop pulses (± 10 V/100 pulses) (Note 2)</td> <td><input type="checkbox"/></td> </tr> <tr> <td>__ 1 1</td> <td>Load-side droop pulses (± 10 V/1000 pulses) (Note 2)</td> <td><input type="checkbox"/></td> </tr> <tr> <td>__ 1 2</td> <td>Load-side droop pulses (± 10 V/10000 pulses) (Note 2)</td> <td><input type="checkbox"/></td> </tr> <tr> <td>__ 1 3</td> <td>Load-side droop pulses (± 10 V/100000 pulses) (Note 2)</td> <td><input type="checkbox"/></td> </tr> <tr> <td>__ 1 4</td> <td>Load-side droop pulses (± 10 V/1 Mpulses) (Note 2)</td> <td><input type="checkbox"/></td> </tr> <tr> <td>__ 1 5</td> <td>Servo motor-side/load-side position deviation (± 10 V/100000 pulses)</td> <td><input type="checkbox"/></td> </tr> <tr> <td>__ 1 6</td> <td>Servo motor-side/load-side speed deviation (± 8 V/max. speed)</td> <td><input type="checkbox"/></td> </tr> <tr> <td>__ 1 7</td> <td>Internal temperature of encoder (± 10 V/± 128 °C)</td> <td><input type="radio"/></td> </tr> </tbody> </table> <p>2. Encoder pulse unit 3. The value in [Pr. PA11] or [Pr. PA12] whichever is higher is applied for the maximum torque</p>							Setting value	Item	Operation mode	Standard	__ 0 0	Servo motor speed (± 8 V/max. speed)	<input type="radio"/>	__ 0 1	Torque (± 8 V/max. torque or max. thrust) (Note 3)	<input type="radio"/>	__ 0 2	Servo motor speed (+8 V/max. speed)	<input type="radio"/>	__ 0 3	Torque (+8 V/max. torque or max. thrust) (Note 3)	<input type="radio"/>	__ 0 4	Current command (± 8 V/max. current command)	<input type="radio"/>	__ 0 5	Speed command (± 8 V/max. speed)	<input type="radio"/>	__ 0 6	Servo motor-side droop pulses (± 10 V/100 pulses) (Note 2)	<input type="radio"/>	__ 0 7	Servo motor-side droop pulses (± 10 V/1000 pulses) (Note 2)	<input type="radio"/>	__ 0 8	Servo motor-side droop pulses (± 10 V/10000 pulses) (Note 2)	<input type="radio"/>	__ 0 9	Servo motor-side droop pulses (± 10 V/100000 pulses) (Note 2)	<input type="radio"/>	__ 0 D	Bus voltage (200 V class and 100 V class: +8 V/400 V, 400 V class: +8 V/800 V)	<input type="radio"/>	__ 0 E	Speed command 2 (± 8 V/max. speed)	<input type="radio"/>	__ 1 0	Load-side droop pulses (± 10 V/100 pulses) (Note 2)	<input type="checkbox"/>	__ 1 1	Load-side droop pulses (± 10 V/1000 pulses) (Note 2)	<input type="checkbox"/>	__ 1 2	Load-side droop pulses (± 10 V/10000 pulses) (Note 2)	<input type="checkbox"/>	__ 1 3	Load-side droop pulses (± 10 V/100000 pulses) (Note 2)	<input type="checkbox"/>	__ 1 4	Load-side droop pulses (± 10 V/1 Mpulses) (Note 2)	<input type="checkbox"/>	__ 1 5	Servo motor-side/load-side position deviation (± 10 V/100000 pulses)	<input type="checkbox"/>	__ 1 6	Servo motor-side/load-side speed deviation (± 8 V/max. speed)	<input type="checkbox"/>	__ 1 7	Internal temperature of encoder (± 10 V/ ± 128 °C)	<input type="radio"/>
Setting value	Item	Operation mode																																																																				
		Standard																																																																				
__ 0 0	Servo motor speed (± 8 V/max. speed)	<input type="radio"/>																																																																				
__ 0 1	Torque (± 8 V/max. torque or max. thrust) (Note 3)	<input type="radio"/>																																																																				
__ 0 2	Servo motor speed (+8 V/max. speed)	<input type="radio"/>																																																																				
__ 0 3	Torque (+8 V/max. torque or max. thrust) (Note 3)	<input type="radio"/>																																																																				
__ 0 4	Current command (± 8 V/max. current command)	<input type="radio"/>																																																																				
__ 0 5	Speed command (± 8 V/max. speed)	<input type="radio"/>																																																																				
__ 0 6	Servo motor-side droop pulses (± 10 V/100 pulses) (Note 2)	<input type="radio"/>																																																																				
__ 0 7	Servo motor-side droop pulses (± 10 V/1000 pulses) (Note 2)	<input type="radio"/>																																																																				
__ 0 8	Servo motor-side droop pulses (± 10 V/10000 pulses) (Note 2)	<input type="radio"/>																																																																				
__ 0 9	Servo motor-side droop pulses (± 10 V/100000 pulses) (Note 2)	<input type="radio"/>																																																																				
__ 0 D	Bus voltage (200 V class and 100 V class: +8 V/400 V, 400 V class: +8 V/800 V)	<input type="radio"/>																																																																				
__ 0 E	Speed command 2 (± 8 V/max. speed)	<input type="radio"/>																																																																				
__ 1 0	Load-side droop pulses (± 10 V/100 pulses) (Note 2)	<input type="checkbox"/>																																																																				
__ 1 1	Load-side droop pulses (± 10 V/1000 pulses) (Note 2)	<input type="checkbox"/>																																																																				
__ 1 2	Load-side droop pulses (± 10 V/10000 pulses) (Note 2)	<input type="checkbox"/>																																																																				
__ 1 3	Load-side droop pulses (± 10 V/100000 pulses) (Note 2)	<input type="checkbox"/>																																																																				
__ 1 4	Load-side droop pulses (± 10 V/1 Mpulses) (Note 2)	<input type="checkbox"/>																																																																				
__ 1 5	Servo motor-side/load-side position deviation (± 10 V/100000 pulses)	<input type="checkbox"/>																																																																				
__ 1 6	Servo motor-side/load-side speed deviation (± 8 V/max. speed)	<input type="checkbox"/>																																																																				
__ 1 7	Internal temperature of encoder (± 10 V/ ± 128 °C)	<input type="radio"/>																																																																				

5. PARAMETERS

No./ symbol/name	Setting digit	Function	Initial value [unit]	Network		
				ECT	EIP	PNT
PC10 MOD2 Analog monitor 2 output	__ x x	Analog monitor 2 output selection Select a signal to output to MO2 (Analog monitor 2). Refer to app. 8.3 for detection point of output selection. Refer to [Pr. PC09] for settings.	01h	<input type="radio"/>	<input type="radio"/>	<input type="radio"/>
	_ x _ _	For manufacturer setting	0h	<input type="checkbox"/>	<input type="checkbox"/>	<input type="checkbox"/>
	x _ _ _		0h	<input type="checkbox"/>	<input type="checkbox"/>	<input type="checkbox"/>
PC11 MO1 Analog monitor 1 offset	/	Set the offset voltage of MO1 (Analog monitor 1). Setting range: -999 to 999	0 [mV]	<input type="radio"/>	<input type="radio"/>	<input type="radio"/>
	/	Set the offset voltage of MO2 (Analog monitor 2). Setting range: -999 to 999	0 [mV]	<input type="radio"/>	<input type="radio"/>	<input type="radio"/>
PC17 **COP4 Function selection C-4	_ _ _ x	For manufacturer setting	0h	<input type="checkbox"/>	<input type="checkbox"/>	<input type="checkbox"/>
	_ _ x _	Linear scale multipoint Z-phase input function selection Do not change this value.	0h	<input type="radio"/>	<input type="radio"/>	<input type="radio"/>
	_ x _ _	For manufacturer setting	0h	<input type="checkbox"/>	<input type="checkbox"/>	<input type="checkbox"/>
	x _ _ _		0h	<input type="checkbox"/>	<input type="checkbox"/>	<input type="checkbox"/>
PC18 *COP5 Function selection C-5	_ _ _ x	For manufacturer setting	0h	<input type="checkbox"/>	<input type="checkbox"/>	<input type="checkbox"/>
	_ _ x _		1h	<input type="checkbox"/>	<input type="checkbox"/>	<input type="checkbox"/>
	_ x _ _		0h	<input type="checkbox"/>	<input type="checkbox"/>	<input type="checkbox"/>
	x _ _ _	[AL. E9 Main circuit off warning] selection Select an occurring condition of [AL. E9 Main circuit off warning]. 0: Detection with ready-on and servo-on command 1: Detection with servo-on command	0h	<input type="radio"/>	<input type="radio"/>	<input type="radio"/>
	/					
PC19 *COP6 Function selection C-6	_ _ _ x	[AL. 99 Stroke limit warning] selection Enable or disable [AL. 99 Stroke limit warning]. 0: Enabled 1: Disabled When "Disabled" is selected, [AL. 99 Stroke limit warning] will not occur while LSP (Forward rotation stroke end) or LSN (Reverse rotation stroke end) is off, but the operation will be stopped with the stroke limit.	0h	<input type="radio"/>	<input type="radio"/>	<input type="radio"/>
	_ _ x _	For manufacturer setting	0h	<input type="checkbox"/>	<input type="checkbox"/>	<input type="checkbox"/>
	_ x _ _		0h	<input type="checkbox"/>	<input type="checkbox"/>	<input type="checkbox"/>
	x _ _ _		0h	<input type="checkbox"/>	<input type="checkbox"/>	<input type="checkbox"/>
	/					

5. PARAMETERS

No./ symbol/name	Setting digit	Function	Initial value [unit]	Network		
				ECT	EIP	PNT
PC20 *COP7 Function selection C-7	__ _ x	[AL. 10 Undervoltage] detection method selection Set this parameter when [AL. 10 undervoltage] occurs due to distorted power supply voltage waveform while using FR-RC-(H) or FR-CV-(H). 0: [AL. 10] not occurrence 1: [AL. 10] occurrence	0h	<input type="radio"/>	<input type="radio"/>	<input type="radio"/>
	__ x _	For manufacturer setting	0h	<input type="checkbox"/>	<input type="checkbox"/>	<input type="checkbox"/>
	_ x _ _	Undervoltage alarm selection Select the alarm and warning that occurs when the bus voltage drops to the undervoltage alarm level. 0: [AL. 10] regardless of servo motor speed 1: [AL. E9] at servo motor speed 50 r/min (50 mm/s) or less, [AL. 10] at over 50 r/min (50 mm/s)	0h	<input type="radio"/>	<input type="radio"/>	<input type="radio"/>
	x _ _ _	For manufacturer setting	0h	<input type="checkbox"/>	<input type="checkbox"/>	<input type="checkbox"/>
PC21 *BPS Alarm history clear	__ _ x	Alarm history clear selection This parameter is used to clear the alarm history. 0: Disabled 1: Enabled When "Enabled" is set, the alarm history will be cleared at the next power-on. Once the alarm history is cleared, the setting becomes disabled automatically.	0h	<input type="radio"/>	<input type="radio"/>	<input type="radio"/>
	__ x _	For manufacturer setting	0h	<input type="checkbox"/>	<input type="checkbox"/>	<input type="checkbox"/>
	_ x _ _		0h	<input type="checkbox"/>	<input type="checkbox"/>	<input type="checkbox"/>
	x _ _ _		0h	<input type="checkbox"/>	<input type="checkbox"/>	<input type="checkbox"/>

5. PARAMETERS

No./ symbol/name	Setting digit	Function	Initial value [unit]	Network		
				ECT	EIP	PNT
PC24 RSBR Forced stop deceleration time constant		<p>Set a deceleration time constant for the forced stop deceleration function. Set the time taken from the rated speed to 0 r/min or 0 mm/s in units of ms. Setting "0" will apply 100 ms.</p> <p>[Precautions]</p> <ul style="list-style-type: none"> • If the servo motor torque or linear servo mot is saturated at the maximum value during forced stop deceleration because the set time is too short, the time to stop the servo motor will be longer than the set time constant. • [AL. 50 Overload 1] or [AL. 51 Overload 2] may occur during forced stop deceleration, depending on the set value. • After an alarm that leads to a forced stop deceleration, if an alarm that does not lead to a forced stop deceleration occurs or if the control circuit power supply is cut, dynamic braking will start regardless of the deceleration time constant setting. <p>This parameter corresponds to "Quick stop deceleration (Index: 6085h)". When this parameter is mapped for the PDO communication, the value written with Setup software (MR Configurator2™) is overwritten with the upper side. Thus, do not write a value with Setup software (MR Configurator2™). Setting range: 0 to 20000</p>	100 [ms]	<input type="radio"/>		
		<p>Set a deceleration time constant for the forced stop deceleration function. Set the time taken from the rated speed to 0 r/min or 0 mm/s in units of ms. Setting "0" will apply 100 ms.</p> <p>[Precautions]</p> <ul style="list-style-type: none"> • If the servo motor torque or linear servo mot is saturated at the maximum value during forced stop deceleration because the set time is too short, the time to stop the servo motor will be longer than the set time constant. • [AL. 50 Overload 1] or [AL. 51 Overload 2] may occur during forced stop deceleration, depending on the set value. • After an alarm that leads to a forced stop deceleration, if an alarm that does not lead to a forced stop deceleration occurs or if the control circuit power supply is cut, dynamic braking will start regardless of the deceleration time constant setting. <p>This parameter corresponds to "Quick stop deceleration (Class ID: 64h, Ins ID: 6085h, Atr ID: 0)". When this parameter is mapped for the I/O communication, the value written with Setup software (MR Configurator2™) is overwritten with the upper side. Thus, do not write a value with Setup software (MR Configurator2™). Setting range: 0 to 20000</p>	100 [ms]		<input type="radio"/>	

5. PARAMETERS

No./ symbol/name	Setting digit	Function	Initial value [unit]	Network		
				ECT	EIP	PNT
PC24 RSBR Forced stop deceleration time constant		<p>Set a deceleration time constant for the forced stop deceleration function. Set the time taken from the rated speed to 0 r/min. Setting "0" will apply 100 ms.</p> <p>[Precautions]</p> <ul style="list-style-type: none"> • If the servo motor torque or linear servo mot is saturated at the maximum value during forced stop deceleration because the set time is too short, the time to stop the servo motor will be longer than the set time constant. • [AL. 50 Overload 1] or [AL. 51 Overload 2] may occur during forced stop deceleration, depending on the set value. • After an alarm that leads to a forced stop deceleration, if an alarm that does not lead to a forced stop deceleration occurs or if the control circuit power supply is cut, dynamic braking will start regardless of the deceleration time constant setting. <p>This parameter corresponds to "Quick stop deceleration (PNU: 24709, Sub: 0)". When this parameter is mapped for the Process Data communication, the value written with Setup software (MR Configurator2™) is overwritten with the upper side. Thus, do not write a value with Setup software (MR Configurator2™).</p> <p>Setting range: 0 to 20000</p>	100 [ms]			○

No./ symbol/name	Setting digit	Function	Initial value [unit]	Network		
				ECT	EIP	PNT
PC26	___ x	For manufacturer setting	0h			
**COP8	__ x _		0h			
Function selection C-8	_ x _ _		0h			
	x _ _ _	Load-side encoder cable communication method selection Do not change this value.	0h	○	○	○
PC27	___ x	Encoder pulse count polarity selection Do not change this value.	0h	○	○	○
**COP9	__ x _	For manufacturer setting	0h			
Function selection C-9	_ x _ _	Selection of A/B/Z-phase input interface encoder Z-phase connection judgment function Do not change this value.r.	0h	○	○	○
	x _ _ _	For manufacturer setting	0h			

5. PARAMETERS

No./ symbol/name	Setting digit	Function	Initial value [unit]	Network																						
				ECT	EIP	PNT																				
PC29 *COPB Function selection C-B	___x	For manufacturer setting	0h																							
	__x_		0h																							
	_x__		0h																							
	x___	POL reflection selection at torque mode Select whether to enable or disable [Pr. PA14 Rotation direction selection/] in the torque mode. When this parameter is enabled, the polarities of "Target torque (Index: 6071h)", "Torque demand (Index: 6074h)", "Positive torque limit value (Index: 60E0h)", "Negative torque limit value (Index: 60E1h)", and "Torque actual value (Index: 6077h)" will be changed with the setting of [Pr. PA14]. 0: Enabled 1: Disabled	1h	<input type="radio"/>																						
	<table border="1"> <thead> <tr> <th colspan="2">Setting value</th> <th colspan="2">Servo motor rotation direction</th> </tr> <tr> <th>[Pr. PA14]</th> <th>[Pr. PC29]</th> <th>Torque mode Torque command: Positive</th> <th>Torque mode Torque command: Negative</th> </tr> </thead> <tbody> <tr> <td rowspan="2">0</td> <td>0 ___: Enabled</td> <td>CCW or positive direction</td> <td>CW or negative direction</td> </tr> <tr> <td>1 ___: Disabled</td> <td>CCW or positive direction</td> <td>CW or negative direction</td> </tr> <tr> <td rowspan="2">1</td> <td>0 ___: Enabled</td> <td>CW or negative direction</td> <td>CCW or positive direction</td> </tr> <tr> <td>1 ___: Disabled</td> <td>CCW or positive direction</td> <td>CW or negative direction</td> </tr> </tbody> </table>	Setting value		Servo motor rotation direction		[Pr. PA14]	[Pr. PC29]	Torque mode Torque command: Positive	Torque mode Torque command: Negative	0	0 ___: Enabled	CCW or positive direction	CW or negative direction	1 ___: Disabled	CCW or positive direction	CW or negative direction	1	0 ___: Enabled	CW or negative direction	CCW or positive direction	1 ___: Disabled	CCW or positive direction	CW or negative direction			
Setting value		Servo motor rotation direction																								
[Pr. PA14]	[Pr. PC29]	Torque mode Torque command: Positive	Torque mode Torque command: Negative																							
0	0 ___: Enabled	CCW or positive direction	CW or negative direction																							
	1 ___: Disabled	CCW or positive direction	CW or negative direction																							
1	0 ___: Enabled	CW or negative direction	CCW or positive direction																							
	1 ___: Disabled	CCW or positive direction	CW or negative direction																							
	POL reflection selection at torque mode Select whether to enable or disable [Pr. PA14 Rotation direction selection/] in the torque mode. When this parameter is enabled, the polarities of "Target torque (Class ID: 64h, Ins ID: 6071h)", "Torque demand (Class ID: 64h, Ins ID: 6074h)", "Positive torque limit value (Class ID: 64h, Ins ID: 60E0h)", "Negative torque limit value (Class ID: 64h, Ins ID: 60E1h)", and "Torque actual value (Class ID: 64h, Ins ID: 6077h)" will be changed with the setting of [Pr. PA14]. 0: Enabled 1: Disabled	1h	<input type="radio"/>																							
	<table border="1"> <thead> <tr> <th colspan="2">Setting value</th> <th colspan="2">Servo motor rotation direction</th> </tr> <tr> <th>[Pr. PA14]</th> <th>[Pr. PC29]</th> <th>Torque mode Torque command: Positive</th> <th>Torque mode Torque command: Negative</th> </tr> </thead> <tbody> <tr> <td rowspan="2">0</td> <td>0 ___: Enabled</td> <td>CCW or positive direction</td> <td>CW or negative direction</td> </tr> <tr> <td>1 ___: Disabled</td> <td>CCW or positive direction</td> <td>CW or negative direction</td> </tr> <tr> <td rowspan="2">1</td> <td>0 ___: Enabled</td> <td>CW or negative direction</td> <td>CCW or positive direction</td> </tr> <tr> <td>1 ___: Disabled</td> <td>CCW or positive direction</td> <td>CW or negative direction</td> </tr> </tbody> </table>	Setting value		Servo motor rotation direction		[Pr. PA14]	[Pr. PC29]	Torque mode Torque command: Positive	Torque mode Torque command: Negative	0	0 ___: Enabled	CCW or positive direction	CW or negative direction	1 ___: Disabled	CCW or positive direction	CW or negative direction	1	0 ___: Enabled	CW or negative direction	CCW or positive direction	1 ___: Disabled	CCW or positive direction	CW or negative direction			
Setting value		Servo motor rotation direction																								
[Pr. PA14]	[Pr. PC29]	Torque mode Torque command: Positive	Torque mode Torque command: Negative																							
0	0 ___: Enabled	CCW or positive direction	CW or negative direction																							
	1 ___: Disabled	CCW or positive direction	CW or negative direction																							
1	0 ___: Enabled	CW or negative direction	CCW or positive direction																							
	1 ___: Disabled	CCW or positive direction	CW or negative direction																							

5. PARAMETERS

No./ symbol/name	Setting digit	Function	Initial value [unit]	Network																								
				ECT	EIP	PNT																						
PC29 *COPB Function selection C-B	x _ _ _	<p>POL reflection selection at torque mode</p> <p>Select whether to enable or disable [Pr. PA14 Rotation direction selection/] in the torque mode. When this parameter is enabled, the polarities of "Target torque (PNU: 24689)", "Torque demand (PNU: 24692)", "Positive torque limit value (PNU: 24800)", "Negative torque limit value (PNU: 24801)", and "Torque actual value (PNU: 24695)" will be changed with the setting of [Pr. PA14].</p> <p>0: Enabled 1: Disabled</p> <table border="1"> <thead> <tr> <th colspan="2">Setting value</th> <th colspan="2">Servo motor rotation direction</th> </tr> <tr> <th>[Pr. PA14]</th> <th>[Pr. PC29]</th> <th>Torque mode Torque command: Positive</th> <th>Torque mode Torque command: Negative</th> </tr> </thead> <tbody> <tr> <td rowspan="2">0</td> <td>0 _ _ _: Enabled</td> <td>CCW or positive direction</td> <td>CW or negative direction</td> </tr> <tr> <td>1 _ _ _: Disabled</td> <td>CCW or positive direction</td> <td>CW or negative direction</td> </tr> <tr> <td rowspan="2">1</td> <td>0 _ _ _: Enabled</td> <td>CW or negative direction</td> <td>CCW or positive direction</td> </tr> <tr> <td>1 _ _ _: Disabled</td> <td>CCW or positive direction</td> <td>CW or negative direction</td> </tr> </tbody> </table>	Setting value		Servo motor rotation direction		[Pr. PA14]	[Pr. PC29]	Torque mode Torque command: Positive	Torque mode Torque command: Negative	0	0 _ _ _: Enabled	CCW or positive direction	CW or negative direction	1 _ _ _: Disabled	CCW or positive direction	CW or negative direction	1	0 _ _ _: Enabled	CW or negative direction	CCW or positive direction	1 _ _ _: Disabled	CCW or positive direction	CW or negative direction	1h			○
Setting value		Servo motor rotation direction																										
[Pr. PA14]	[Pr. PC29]	Torque mode Torque command: Positive	Torque mode Torque command: Negative																									
0	0 _ _ _: Enabled	CCW or positive direction	CW or negative direction																									
	1 _ _ _: Disabled	CCW or positive direction	CW or negative direction																									
1	0 _ _ _: Enabled	CW or negative direction	CCW or positive direction																									
	1 _ _ _: Disabled	CCW or positive direction	CW or negative direction																									
PC31 RSUP1 Vertical axis freefall prevention compensation amount		<p>Set the compensation amount of the vertical axis freefall prevention function. Set it per servo motor rotation amount or linear servo motor travel distance. When setting a positive value, the servo motor or linear servo motor moves in the direction set with [Pr. PA14] for the forward rotation pulse input. When setting a negative value, the servo motor or linear servo motor moves in the direction set with [Pr. PA14] for the reverse rotation pulse input.</p> <p>For example, when [Pr. PA14 Rotation direction selection/] is set to "1" and a positive value is set for the compensation amount, the servo motor pulls up in the CW direction.</p> <p>The vertical axis freefall prevention function is performed when all of the following conditions are met.</p> <ol style="list-style-type: none"> 1) Position mode 2) The setting value of this parameter is other than "0". 3) The forced stop deceleration function is enabled. 4) Alarm occurs or EM2 turns off when the servo motor speed is zero speed or less. 5) MBR (Electromagnetic brake interlock) was enabled in [Pr. PD07] to [Pr. PD09], and the base circuit shut-off delay time was set in [Pr. PC02]. <p>Setting range: -25000 to 25000</p>	0 [0.0001 rev]/ [0.01 mm]	○	○	○																						
PC38 ERW Error excessive warning level		<p>Set an error excessive warning level.</p> <p>The setting unit can be changed with "Error excessive alarm/error excessive warning level unit selection" in [Pr. PC06].</p> <p>Set this per rev. for rotary servo motors and direct drive motors. Setting over 200 rev will be clamped with 200 rev. Set this per mm for linear servo motors. However, setting "0" will not trigger [AL. 9B Error excessive warning].</p> <p>When an error reaches the set value, [AL. 9B Error excessive warning] will occur. When the error decreases lower than the set value, the warning will be canceled automatically. The minimum pulse width of the warning signal is 100 [ms].</p> <p>Set as follows.: [Pr. PC38 Error excessive warning level] < [Pr. PC01 Error excessive alarm level] When you set as follows, [AL. 52 Error excessive] will occur earlier than the warning.: [Pr. PC38 Error excessive warning level] ≥ [Pr. PC01 Error excessive alarm level]</p> <p>Setting range: 0 to 1000</p>	0 [rev]/ [mm]	○	○	○																						

5. PARAMETERS

No./ symbol/name	Setting digit	Function	Initial value [unit]	Network		
				ECT	EIP	PNT
PC65 ZSP2L Zero speed 2 level		<p>Set a speed level for turning on the zero speed 2.</p> <p>When the state in which the absolute value of the servo motor speed exceeds the parameter setting value continues for the time set in [Pr. PC66 Zero speed 2 filtering time] or longer, "Statusword (Index: 6041h) bit 12 Speed" will be turned off.</p> <p>This function will be enabled in the profile velocity mode (pv).</p> <p>This parameter corresponds to "Velocity threshold (Index: 606Fh)". When this parameter is mapped for the PDO communication, the value written with Setup software (MR Configurator2™) is overwritten with the upper side. Thus, do not write a value with Setup software (MR Configurator2™).</p> <p>Setting range: 0.00 to 655.35</p>	50.00 [r/min]/ [mm/s]	<input type="radio"/>		
		<p>Set a speed level for turning on the zero speed 2.</p> <p>When the state in which the absolute value of the servo motor speed exceeds the parameter setting value continues for the time set in [Pr. PC66 Zero speed 2 filtering time] or longer, "Statusword (Class ID: 64h, Ins ID: 6041h) bit 12 Speed" will be turned off.</p> <p>This function will be enabled in the profile velocity mode (pv).</p> <p>This parameter corresponds to "Velocity threshold (Class ID: 64h, Ins ID: 606Fh, Attr ID: 0)". When this parameter is mapped for the I/O communication, the value written with Setup software (MR Configurator2™) is overwritten with the upper side. Thus, do not write a value with Setup software (MR Configurator2™).</p> <p>Setting range: 0.00 to 655.35</p>	50.00 [r/min]/ [mm/s]		<input type="radio"/>	
		<p>Set a speed level for turning on the zero speed 2.</p> <p>When the state in which the absolute value of the servo motor speed exceeds the parameter setting value continues for the time set in [Pr. PC66 Zero speed 2 filtering time] or longer, "Statusword (PNU: 24641) bit 12 Speed" will be turned off.</p> <p>This function will be enabled in the profile velocity mode (pv).</p> <p>This parameter corresponds to "Velocity threshold (PNU: 24687, Sub: 0)". When this parameter is mapped for the Process Data communication, the value written with Setup software (MR Configurator2™) is overwritten with the upper side. Thus, do not write a value with Setup software (MR Configurator2™).</p> <p>Setting range: 0.00 to 655.35</p>	50.00 [r/min]/ [mm/s]			<input type="radio"/>
PC66 ZSP2F Zero speed 2 filtering time		<p>Set the zero speed 2 filtering time.</p> <p>When the state in which the absolute value of the servo motor speed exceeds [Pr. PC65 Zero speed 2 level] continues for the time set in this parameter or longer, "Statusword (Index: 6041h) bit 12 Speed" will be turned off.</p> <p>This function will be enabled in the profile velocity mode (pv).</p> <p>This parameter corresponds to "Velocity threshold time (Index: 6070h)". When this parameter is mapped for the PDO communication, the value written with Setup software (MR Configurator2™) is overwritten with the upper side. Thus, do not write a value with Setup software (MR Configurator2™).</p> <p>Setting range: 0 to 65535</p>	10 [ms]	<input type="radio"/>		
		<p>Set the zero speed 2 filtering time.</p> <p>When the state in which the absolute value of the servo motor speed exceeds [Pr. PC65 Zero speed 2 level] continues for the time set in this parameter or longer, "Statusword (Class ID: 64h, Ins ID: 6041h) bit 12 Speed" will be turned off.</p> <p>This function will be enabled in the profile velocity mode (pv).</p> <p>This parameter corresponds to "Velocity threshold time (Class ID: 64h, Ins ID: 6070h, Attr ID: 0)". When this parameter is mapped for the I/O communication, the value written with Setup software (MR Configurator2™) is overwritten with the upper side. Thus, do not write a value with Setup software (MR Configurator2™).</p> <p>Setting range: 0 to 65535</p>	10 [ms]		<input type="radio"/>	

5. PARAMETERS

No./ symbol/name	Setting digit	Function	Initial value [unit]	Network		
				ECT	EIP	PNT
PC66 ZSP2F Zero speed 2 filtering time		<p>Set the zero speed 2 filtering time.</p> <p>When the state in which the absolute value of the servo motor speed exceeds [Pr. PC65 Zero speed 2 level] continues for the time set in this parameter or longer, "Statusword (PNU: 24641) bit 12 Speed" will be turned off.</p> <p>This function will be enabled in the profile velocity mode (pv).</p> <p>This parameter corresponds to "Velocity threshold time (PNU: 24688, Sub: 0)". When this parameter is mapped for the Process Data communication, the value written with Setup software (MR Configurator2™) is overwritten with the upper side. Thus, do not write a value with Setup software (MR Configurator2™).</p> <p>Setting range: 0 to 65535</p>	10 [ms]			○
PC67 FEWL Following error output level (lower four digits)		<p>Set a following error output level.</p> <p>Upper and lower are a set.</p> <p>When the state in which droop pulses \geq the parameter setting value continues for the time set in [Pr. PC69 Following error output filtering time], "Statusword (Index: 6041h) bit 13 Following error" will be turned on. However, setting "FFFFFFFFh" will disable it.</p> <p>Set a value in hexadecimal.</p> <p>Setting value:</p> <div style="text-align: center;"> </div> <p>This function is enabled in the cyclic synchronous position mode (csp), profile position mode (pp), point table mode (pt), Jog mode (jg) and indexer mode (idx). The unit can be changed to 10^{STM} [μm], $10^{\text{STM}-4}$ [inch], 10^{-3} [degree] or [pulse] according to the setting of [Pr. PT01].</p> <p>This parameter corresponds to "Following error window (Index: 6065h)". When this parameter is mapped for the PDO communication, the value written with Setup software (MR Configurator2™) is overwritten with the upper side. Thus, do not write a value with Setup software (MR Configurator2™).</p> <p>Setting range: 00000000h to FFFFFFFFh</p>	0000h Refer to Function Column for unit.	○		

5. PARAMETERS

No./ symbol/name	Setting digit	Function	Initial value [unit]	Network		
				ECT	EIP	PNT
PC67 FEWL Following error output level (lower four digits)		<p>Set a following error output level. Upper and lower are a set. When the state in which droop pulses \geq the parameter setting value continues for the time set in [Pr. PC69 Following error output filtering time], "Statusword (Class ID: 64h, Ins ID: 6041h, Attr ID: 0) bit 13 Following error" will be turned on. However, setting "FFFFFFFFh" will disable it. Set a value in hexadecimal.</p> <p>Setting value:</p> <div style="text-align: center;"> </div> <p>This function is enabled in the profile position mode (pp). The unit can be changed to 10^{STM} [μm], $10^{(\text{STM}-4)}$ [inch], 10^{-3} [degree] or [pulse] according to the setting of [Pr. PT01].</p> <p>This parameter corresponds to "Following error window (Class ID: 64h, Ins ID: 6065h, Attr ID: 0)". When this parameter is mapped for the I/O communication, the value written with Setup software (MR Configurator2™) is overwritten with the upper side. Thus, do not write a value with Setup software (MR Configurator2™).</p> <p>Setting range: 00000000h to FFFFFFFFh</p>	0000h Refer to Function column for unit.		○	
		<p>Set a following error output level. Upper and lower are a set. When the state in which droop pulses \geq the parameter setting value continues for the time set in [Pr. PC69 Following error output filtering time], "Statusword (PNU: 24641, Sub: 0) bit 13 Following error" will be turned on. However, setting "FFFFFFFFh" will disable it. Set a value in hexadecimal.</p> <p>Setting value:</p> <div style="text-align: center;"> </div> <p>This function is enabled in the profile position mode (pp), point table mode (pt), Jog mode (jg) and indexer mode (idx). The unit can be changed to 10^{STM} [μm], $10^{(\text{STM}-4)}$ [inch], 10^{-3} [degree] or [pulse] according to the setting of [Pr. PT01].</p> <p>This parameter corresponds to "Following error window (PNU: 24677, Sub: 0)". When this parameter is mapped for the Process Data communication, the value written with Setup software (MR Configurator2™) is overwritten with the upper side. Thus, do not write a value with Setup software (MR Configurator2™).</p> <p>Setting range: 00000000h to FFFFFFFFh</p>	0000h Refer to Function column for unit.			○
PC68 FEWH Following error output level (upper four digits)		<p>Set a following error output level. Upper and lower are a set. Refer to [Pr. PC67] for details. The unit can be changed to 10^{STM} [μm], $10^{(\text{STM}-4)}$ [inch], 10^{-3} [degree] or [pulse] according to the setting of [Pr. PT01].</p>	0000h Refer to Function column for unit.	○	○	○

5. PARAMETERS

No./ symbol/name	Setting digit	Function	Initial value [unit]	Network		
				ECT	EIP	PNT
PC69 FEWF Following error output filtering time		<p>Set the time until the following error output turns on. When the state in which droop pulses \geq [Pr. PC67/Pr. PC68 Following error output level] continues for the time set in the parameter setting value, "Statusword (Index: 6041h) bit 13 Following error" will be turned on. This function is enabled in the cyclic synchronous position mode (csp), profile position mode (pp), point table mode (pt), Jog mode (jg) and indexer mode (idx). The following error output will be disabled when both [Pr. PC67] and [Pr. PC68] are "FFFFh".</p> <p>This parameter corresponds to "Following error time out (Index: 6066h)". When this parameter is mapped for the PDO communication, the value written with Setup software (MR Configurator2™) is overwritten with the upper side. Thus, do not write a value with Setup software (MR Configurator2™).</p> <p>Setting range: 0 to 65535</p>	10 [ms]	○		
		<p>Set the time until the following error output turns on. When the state in which droop pulses \geq [Pr. PC67/Pr. PC68 Following error output level] continues for the time set in the parameter setting value, "Statusword (Class ID: 64h, Ins ID: 6041h) bit 13 Following error" will be turned on. This function is enabled in the profile position mode (pp). The following error output will be disabled when both [Pr. PC67] and [Pr. PC68] are "FFFFh".</p> <p>This parameter corresponds to "Following error time out (Class ID: 64h, Ins ID: 6066h, Attr ID: 0)". When this parameter is mapped for the I/O communication, the value written with Setup software (MR Configurator2™) is overwritten with the upper side. Thus, do not write a value with Setup software (MR Configurator2™).</p> <p>Setting range: 0 to 65535</p>	10 [ms]		○	
		<p>Set the time until the following error output turns on. When the state in which droop pulses \geq [Pr. PC67/Pr. PC68 Following error output level] continues for the time set in the parameter setting value, "Statusword (PNU: 24641) bit 13 Following error" will be turned on. This function is enabled in the profile position mode (pp), point table mode (pt), Jog mode (jg) and indexer mode (idx). The following error output will be disabled when both [Pr. PC67] and [Pr. PC68] are "FFFFh".</p> <p>This parameter corresponds to "Following error time out (PNU: 24678, Sub: 0)". When this parameter is mapped for the Process Data communication, the value written with Setup software (MR Configurator2™) is overwritten with the upper side. Thus, do not write a value with Setup software (MR Configurator2™).</p> <p>Setting range: 0 to 65535</p>	10 [ms]			○

5. PARAMETERS

No./ symbol/name	Setting digit	Function	Initial value [unit]	Network		
				ECT	EIP	PNT
PC70 INP2R In-position 2 output range		<p>Set a position range for turning on the in-position 2 output.</p> <p>When the state in which an error between the command position and current position is within the parameter setting value continues for the time set in [Pr. PC71 In-position 2 output filtering time] or longer, "Statusword (Index: 6041h) bit 10 Target reached" will be turned on. However, when this parameter is set to "65535", "Statusword (Index: 6041h) bit 10 Target reached" will be always on.</p> <p>This function is enabled in the profile position mode (pp), point table mode (pt) and Jog mode (jg).</p> <p>The unit can be changed to 10^{STM} [μm], 10^(STM-4) [inch], 10⁻³ [degree] or [pulse] according to the setting of [Pr. PT01].</p> <p>This parameter corresponds to "Position window (Index: 6067h)". When this parameter is mapped for the PDO communication, the value written with Setup software (MR Configurator2™) is overwritten with the upper side. Thus, do not write a value with Setup software (MR Configurator2™).</p> <p>Setting range: 0 to 65535</p>	100 Refer to Function column for unit.	<input type="radio"/>		
		<p>Set a position range for turning on the in-position 2 output.</p> <p>When the state in which an error between the command position and current position is within the parameter setting value continues for the time set in [Pr. PC71 In-position 2 output filtering time] or longer, "Statusword (Class ID: 64h, Ins ID: 6041h) bit 10 Target reached" will be turned on. However, when the parameter is set to "65535", "Statusword (Class ID: 64h, Ins ID: 6041h) bit 10 Target reached" will be always on.</p> <p>This function is enabled in the profile position mode (pp).</p> <p>The unit can be changed to 10^{STM} [μm], 10^(STM-4) [inch], 10⁻³ [degree] or [pulse] according to the setting of [Pr. PT01].</p> <p>This parameter corresponds to "Position window (Class ID: 64h, Ins ID: 6067h, Attr ID: 0)". When this parameter is mapped for the I/O communication, the value written with Setup software (MR Configurator2™) is overwritten with the upper side. Thus, do not write a value with Setup software (MR Configurator2™).</p> <p>Setting range: 0 to 65535</p>	100 Refer to Function column for unit.		<input type="radio"/>	
		<p>Set a position range for turning on the in-position 2 output.</p> <p>When the state in which an error between the command position and current position is within the parameter setting value continues for the time set in [Pr. PC71 In-position 2 output filtering time] or longer, "Statusword (PNU: 24641) bit 10 Target reached" will be turned on. However, when the parameter is set to "65535", "Statusword (PNU: 24641) bit 10 Target reached" will be always on.</p> <p>This function is enabled in the profile position mode (pp), point table mode (pt) and Jog mode (jg).</p> <p>The unit can be changed to 10^{STM} [μm], 10^(STM-4) [inch], 10⁻³ [degree] or [pulse] according to the setting of [Pr. PT01].</p> <p>This parameter corresponds to "Position window (PNU: 24679, Sub: 0)". When this parameter is mapped for the Process Data communication, the value written with Setup software (MR Configurator2™) is overwritten with the upper side. Thus, do not write a value with Setup software (MR Configurator2™).</p> <p>Setting range: 0 to 65535</p>	100 Refer to Function column for unit.			<input type="radio"/>

5. PARAMETERS

No./ symbol/name	Setting digit	Function	Initial value [unit]	Network		
				ECT	EIP	PNT
PC71 INP2F In-position 2 output filtering time		<p>Set the time until the in-position 2 output turns on.</p> <p>When the state in which an error between the command position and current position is within [Pr. PC70 In-position 2 output range] continues for the time set in this parameter or longer, "Statusword (Index: 6041h) bit 10 Target reached" will be turned on. However, when this parameter is set to "65535", "Statusword (Index: 6041h) bit 10 Target reached" will be always on.</p> <p>This function is enabled in the profile position mode (pp), point table mode (pt) and Jog mode (jg).</p> <p>This parameter corresponds to "Position window time (Index: 6068h)". When this parameter is mapped for the PDO communication, the value written with Setup software (MR Configurator2™) is overwritten with the upper side. Thus, do not write a value with Setup software (MR Configurator2™).</p> <p>Setting range: 0 to 65535</p>	10 [ms]	○		
		<p>Set the time until the in-position 2 output turns on.</p> <p>When the state in which an error between the command position and current position is within [Pr. PC70 In-position 2 output range] continues for the time set in this parameter or longer, "Statusword (Class ID: 64h, Ins ID: 6041h) bit 10 Target reached" will be turned on. However, when the parameter is set to "65535", "Statusword (Class ID: 64h, Ins ID: 6041h) bit 10 Target reached" will be always on.</p> <p>This function is enabled in the profile position mode (pp).</p> <p>This parameter corresponds to "Position window time (Class ID: 64h, Ins ID: 6068h, Attr ID: 0)". When this parameter is mapped for the I/O communication, the value written with Setup software (MR Configurator2™) is overwritten with the upper side. Thus, do not write a value with Setup software (MR Configurator2™).</p> <p>Setting range: 0 to 65535</p>	10 [ms]		○	
		<p>Set the time until the in-position 2 output turns on.</p> <p>When the state in which an error between the command position and current position is within [Pr. PC70 In-position 2 output range] continues for the time set in this parameter or longer, "Statusword (PNU: 24641) bit 10 Target reached" will be turned on. However, when the parameter is set to "65535", "Statusword (PNU: 24641) bit 10 Target reached" will be always on.</p> <p>This function is enabled in the profile position mode (pp), point table mode (pt) and Jog mode (jg).</p> <p>This parameter corresponds to "Position window time (PNU: 24680, Sub: 0)". When this parameter is mapped for the Process Data communication, the value written with Setup software (MR Configurator2™) is overwritten with the upper side. Thus, do not write a value with Setup software (MR Configurator2™).</p> <p>Setting range: 0 to 65535</p>	10 [ms]			○

5. PARAMETERS

No./ symbol/name	Setting digit	Function	Initial value [unit]	Network		
				ECT	EIP	PNT
PC72 SA2R Speed reached 2 output range		<p>Set a speed range for turning on the speed reached 2 output. When the state in which an error between the command speed and servo motor speed is within the parameter setting value continues for the time set in [Pr. PC73 Speed reached 2 output filtering time] or longer, "Statusword (Index: 6041h) bit 10 Target velocity reached" will be turned on. This function will be enabled in the profile velocity mode (pv).</p> <p>This parameter corresponds to "Velocity window (Index: 606Dh)". When this parameter is mapped for the PDO communication, the value written with Setup software (MR Configurator2™) is overwritten with the upper side. Thus, do not write a value with Setup software (MR Configurator2™).</p> <p>Setting range: 0.00 to 655.35</p>	20.00 [r/min]/ [mm/s]	<input type="radio"/>		
		<p>Set a speed range for turning on the speed reached 2 output. When the state in which an error between the command speed and servo motor speed is within the parameter setting value continues for the time set in [Pr. PC73 Speed reached 2 output filtering time] or longer, "Statusword (Class ID: 64h, Ins ID: 6041h) bit 10 Target velocity reached" will be turned on. This function will be enabled in the profile velocity mode (pv).</p> <p>This parameter corresponds to "Velocity window (Class ID: 64h, Ins ID: 606Dh, Attr ID: 0)". When this parameter is mapped for the I/O communication, the value written with Setup software (MR Configurator2™) is overwritten with the upper side. Thus, do not write a value with Setup software (MR Configurator2™).</p> <p>Setting range: 0.00 to 655.35</p>	20.00 [r/min]/ [mm/s]		<input type="radio"/>	
		<p>Set a speed range for turning on the speed reached 2 output. When the state in which an error between the command speed and servo motor speed is within the parameter setting value continues for the time set in [Pr. PC73 Speed reached 2 output filtering time] or longer, "Statusword (PNU: 24641) bit 10 Target velocity reached" will be turned on. This function will be enabled in the profile velocity mode (pv).</p> <p>This parameter corresponds to "Velocity window (PNU: 24685, Sub: 0)". When this parameter is mapped for the Process Data communication, the value written with Setup software (MR Configurator2™) is overwritten with the upper side. Thus, do not write a value with Setup software (MR Configurator2™).</p> <p>Setting range: 0.00 to 655.35</p>	20.00 [r/min]/ [mm/s]			<input type="radio"/>

5. PARAMETERS

No./ symbol/name	Setting digit	Function	Initial value [unit]	Network		
				ECT	EIP	PNT
PC73 SA2F Speed reached 2 output filtering time		<p>Set the time until the speed reached 2 output turns on. When the state in which an error between the speed command and servo motor speed is within [Pr. PC72 Speed reached 2 output range] continues for the time set in this parameter or longer, "Statusword (Index: 6041h) bit 10 Target velocity reached" will be turned on. This function will be enabled in the profile velocity mode (pv).</p> <p>This parameter corresponds to "Velocity window time (Index: 606Eh)". When this parameter is mapped for the PDO communication, the value written with Setup software (MR Configurator2™) is overwritten with the upper side. Thus, do not write a value with Setup software (MR Configurator2™).</p> <p>Setting range: 0 to 65535</p>	10 [ms]	<input type="radio"/>		
		<p>Set the time until the speed reached 2 output turns on. When the state in which an error between the speed command and servo motor speed is within [Pr. PC72 Speed reached 2 output range] continues for the time set in this parameter or longer, "Statusword (Class ID: 64h, Ins ID: 6041h) bit 10 Target velocity reached" will be turned on. This function will be enabled in the profile velocity mode (pv).</p> <p>This parameter corresponds to "Velocity window time (Class ID: 64h, Ins ID: 606Eh, Attr ID: 0)". When this parameter is mapped for the I/O communication, the value written with Setup software (MR Configurator2™) is overwritten with the upper side. Thus, do not write a value with Setup software (MR Configurator2™).</p> <p>Setting range: 0 to 65535</p>	10 [ms]		<input type="radio"/>	
		<p>Set the time until the speed reached 2 output turns on. When the state in which an error between the speed command and servo motor speed is within [Pr. PC72 Speed reached 2 output range] continues for the time set in this parameter or longer, "Statusword (PNU: 24641) bit 10 Target velocity reached" will be turned on. This function will be enabled in the profile velocity mode (pv).</p> <p>This parameter corresponds to "Velocity window time (PNU: 24686, Sub: 0)". When this parameter is mapped for the Process Data communication, the value written with Setup software (MR Configurator2™) is overwritten with the upper side. Thus, do not write a value with Setup software (MR Configurator2™).</p> <p>Setting range: 0 to 65535</p>	10 [ms]			<input type="radio"/>

5. PARAMETERS

No./ symbol/name	Setting digit	Function	Initial value [unit]	Network																
				ECT	EIP	PNT														
PC76 *COPE Function selection C-E	___x	For manufacturer setting	1h																	
	__x_		0h																	
	_x__	Internal command speed POL reflection selection When this parameter is enabled, the polarity of "Velocity demand value (Index: 606Bh)" can be changed depending on the setting of [Pr. PA14 Rotation direction selection/]. 0: Automatic setting (POL setting disabled) 1: POL setting enabled 2: POL setting disabled	0h	○																
		Internal command speed POL reflection selection When this parameter is enabled, the polarity of "Velocity demand value (Class ID: 64h, Ins ID: 606Bh)" can be changed depending on the setting of [Pr. PA14 Rotation direction selection/]. 0: Automatic setting (POL setting enabled) 1: POL setting enabled 2: POL setting disabled	0h		○															
		Internal command speed POL reflection selection When this parameter is enabled, the polarity of "Velocity demand value (PNU: 24683)" can be changed depending on the setting of [Pr. PA14 Rotation direction selection/]. 0: Automatic setting (POL setting enabled) 1: POL setting enabled 2: POL setting disabled	0h			○														
	x___	Limit switch status reading selection Select the on/off statuses of "Digital inputs (Index: 60FDh)" for the on/off statuses of LSP (Forward rotation stroke end) and LSN (Reverse rotation stroke end). Refer to the following table for details.	0h	○																
		Limit switch status reading selection Select the on/off statuses of "Digital inputs (Class ID: 64h, Ins ID: 60FDh, Attr ID: 0)" for the on/off statuses of LSP (Forward rotation stroke end) and LSN (Reverse rotation stroke end). Refer to the following table for details.	0h		○															
		Limit switch status reading selection Select the on/off statuses of "Digital inputs (PNU: 24829, Sub: 0)" for the on/off statuses of LSP (Forward rotation stroke end) and LSN (Reverse rotation stroke end). Refer to the following table for details.	0h			○														
	<table border="1" style="margin-left: auto; margin-right: auto;"> <thead> <tr> <th>[Pr. PC76]</th> <th>LSP/LSN</th> <th>Digital inputs (Note)</th> </tr> </thead> <tbody> <tr> <td rowspan="2">0 ___</td> <td>Off</td> <td>Off</td> </tr> <tr> <td>On</td> <td>On</td> </tr> <tr> <td rowspan="2">1 ___</td> <td>Off</td> <td>On</td> </tr> <tr> <td>On</td> <td>Off</td> </tr> </tbody> </table> <p style="text-align: center;">Note. For details of "Digital inputs", refer to chapter 18,19,20.</p>							[Pr. PC76]	LSP/LSN	Digital inputs (Note)	0 ___	Off	Off	On	On	1 ___	Off	On	On	Off
	[Pr. PC76]	LSP/LSN	Digital inputs (Note)																	
0 ___	Off	Off																		
	On	On																		
1 ___	Off	On																		
	On	Off																		

5. PARAMETERS

No./ symbol/name	Setting digit	Function	Initial value [unit]	Network																										
				ECT	EIP	PNT																								
PC79 *COP10 Function selection C- 10	Select whether the on/off status of the input device is returned or the on/off status of the pins are returned when reading "Digital inputs". For details of "Digital inputs", refer to chapter 18,19,20.																													
	----x (HEX)	----x (BIN): For manufacturer setting	0h																											
		__x_ (BIN): DI1 status reading selection Select DI1 (bit 17) status reading. 0: The on/off status of the input device is returned. 1: The on/off status of the CN3-2 pin is returned.																												
		_x__ (BIN): DI2 status reading selection Select DI2 (bit 18) status reading. 0: The on/off status of the input device is returned. 1: The on/off status of the CN3-12 pin is returned.																												
		x___ (BIN): DI3 status reading selection Select DI3 (bit 19) status reading. 0: The on/off status of the input device is returned. 1: The on/off status of the CN3-19 pin is returned.																												
	--x_ (HEX)	___x (BIN): DI4 status reading selection Select DI4 (bit 20) status reading. 0: The on/off status of the input device is returned. 1: The on/off status of the CN3-10 pin is returned.	0h																											
		__x_ (BIN): DI5 status reading selection Select DI5 (bit 21) status reading. 0: The on/off status of the input device is returned. 1: The on/off status of the CN3-1 pin is returned.																												
		_x__ (BIN): EM2/EM1 status reading selection Select EM2/EM1 (bit 22) status reading. 0: The on/off status of the input device is returned. 1: The on/off status of the CN3-20 pin is returned.																												
		x___ (BIN): For manufacturer setting																												
		_x__ For manufacturer setting	0h																											
	x___ For manufacturer setting	0h																												
Convert the setting value into hexadecimal as follows.																														
<table border="1" style="margin-left: 20px;"> <thead> <tr> <th rowspan="2">Signal name</th> <th colspan="2">Initial value</th> </tr> <tr> <th>BIN</th> <th>HEX</th> </tr> </thead> <tbody> <tr> <td>DI1 status reading selection</td> <td>0</td> <td rowspan="3">0</td> </tr> <tr> <td>DI2 status reading selection</td> <td>0</td> </tr> <tr> <td>DI3 status reading selection</td> <td>0</td> </tr> </tbody> </table> <table border="1" style="margin-left: 20px;"> <thead> <tr> <th rowspan="2">Signal name</th> <th colspan="2">Initial value</th> </tr> <tr> <th>BIN</th> <th>HEX</th> </tr> </thead> <tbody> <tr> <td>DI4 status reading selection</td> <td>0</td> <td rowspan="3">0</td> </tr> <tr> <td>DI5 status reading selection</td> <td>0</td> </tr> <tr> <td>EM2/EM1 status reading selection</td> <td>0</td> </tr> </tbody> </table> <p style="margin-left: 20px;">BIN 0: The on/off status of the input device is returned. BIN 1: The on/off status of the pin is returned.</p>							Signal name	Initial value		BIN	HEX	DI1 status reading selection	0	0	DI2 status reading selection	0	DI3 status reading selection	0	Signal name	Initial value		BIN	HEX	DI4 status reading selection	0	0	DI5 status reading selection	0	EM2/EM1 status reading selection	0
Signal name	Initial value																													
	BIN	HEX																												
DI1 status reading selection	0	0																												
DI2 status reading selection	0																													
DI3 status reading selection	0																													
Signal name	Initial value																													
	BIN	HEX																												
DI4 status reading selection	0	0																												
DI5 status reading selection	0																													
EM2/EM1 status reading selection	0																													

5. PARAMETERS

5.2.4 I/O setting parameters ([Pr. PD_ _])

No./ symbol/name	Setting digit	Function	Initial value [unit]	Network																								
				ECT	EIP	PNT																						
PD01 *DIA1 Input signal automatic on selection 1	Select input devices to turn on automatically.																											
	___x	For manufacturer setting		0h																								
	__x_			0h																								
	_x__ (HEX)	___x (BIN): For manufacturer setting		0h	○	○	○																					
		__x_ (BIN): For manufacturer setting																										
		_x__ (BIN): LSP (Forward rotation stroke end) 0: Disabled (Use for an external input signal.) 1: Enabled (automatic on)																										
	x___ (BIN): LSN (Reverse rotation stroke end) 0: Disabled (Use for an external input signal.) 1: Enabled (automatic on)																											
x___	For manufacturer setting		0h																									
Convert the setting value into hexadecimal as follows.																												
<table border="1" style="margin-left: auto; margin-right: auto;"> <thead> <tr> <th rowspan="2">Signal name</th> <th colspan="2">Initial value</th> </tr> <tr> <th>BIN</th> <th>HEX</th> </tr> </thead> <tbody> <tr> <td></td> <td>0</td> <td rowspan="4">0</td> </tr> <tr> <td></td> <td>0</td> </tr> <tr> <td>LSP (Forward rotation stroke end)</td> <td>0</td> </tr> <tr> <td>LSN (Reverse rotation stroke end)</td> <td>0</td> </tr> </tbody> </table> <p style="text-align: center;">BIN 0: Use for an external input signal. BIN 1: Automatic on</p>							Signal name	Initial value		BIN	HEX		0	0		0	LSP (Forward rotation stroke end)	0	LSN (Reverse rotation stroke end)	0								
Signal name	Initial value																											
	BIN	HEX																										
	0	0																										
	0																											
LSP (Forward rotation stroke end)	0																											
LSN (Reverse rotation stroke end)	0																											
PD03 *DI1 Input device selection 1	Any input device can be assigned to the CN3-2 pin.																											
	__xx	Device selection Refer to table 5.9 for settings.		0Ah	○	○	○																					
	_x__	For manufacturer setting		0h																								
	x___			0h																								
Table 5.9 Selectable input devices <table border="1" style="margin-left: auto; margin-right: auto;"> <thead> <tr> <th>Setting value</th> <th>Input device</th> </tr> </thead> <tbody> <tr> <td>__00</td> <td></td> </tr> <tr> <td>__04</td> <td>PC (Proportional control)</td> </tr> <tr> <td>__0A</td> <td>LSP (Forward rotation stroke end)</td> </tr> <tr> <td>__0B</td> <td>LSN (Reverse rotation stroke end)</td> </tr> <tr> <td>__0D</td> <td>CDP (Gain switching)</td> </tr> <tr> <td>__0E</td> <td>CLD (Fully closed loop selection)</td> </tr> <tr> <td>__22</td> <td>DOG (Proximity dog)</td> </tr> <tr> <td>__28</td> <td>DIA (General-purpose input A) (Note)</td> </tr> <tr> <td>__29</td> <td>DIB (General-purpose input B) (Note)</td> </tr> <tr> <td>__2A</td> <td>DIC (General-purpose input C) (Note)</td> </tr> </tbody> </table>							Setting value	Input device	__00		__04	PC (Proportional control)	__0A	LSP (Forward rotation stroke end)	__0B	LSN (Reverse rotation stroke end)	__0D	CDP (Gain switching)	__0E	CLD (Fully closed loop selection)	__22	DOG (Proximity dog)	__28	DIA (General-purpose input A) (Note)	__29	DIB (General-purpose input B) (Note)	__2A	DIC (General-purpose input C) (Note)
Setting value	Input device																											
__00																												
__04	PC (Proportional control)																											
__0A	LSP (Forward rotation stroke end)																											
__0B	LSN (Reverse rotation stroke end)																											
__0D	CDP (Gain switching)																											
__0E	CLD (Fully closed loop selection)																											
__22	DOG (Proximity dog)																											
__28	DIA (General-purpose input A) (Note)																											
__29	DIB (General-purpose input B) (Note)																											
__2A	DIC (General-purpose input C) (Note)																											

5. PARAMETERS

No./ symbol/name	Setting digit	Function	Initial value [unit]	Network																																										
				ECT	EIP	PNT																																								
PD04 *DI2 Input device selection 2	Any input device can be assigned to the CN3-12 pin.																																													
	__ x x	Device selection Refer to table 5.9 in [Pr. PD03] for settings.	0Bh	○	○	○																																								
	_ x _ _	For manufacturer setting	0h	▧	▧	▧																																								
	x _ _ _		0h	▧	▧	▧																																								
PD05 *DI3 Input device selection 3	Any input device can be assigned to the CN3-19 pin.																																													
	__ x x	Device selection Refer to table 5.9 in [Pr. PD03] for settings.	22h	○	○	○																																								
	_ x _ _	For manufacturer setting	0h	▧	▧	▧																																								
	x _ _ _		0h	▧	▧	▧																																								
PD07 *DO1 Output device selection 1	Any output device can be assigned to the CN3-13 pin. As the initial value, MBR (Electromagnetic brake interlock) is assigned to the pin. Refer to table 5.10 for settings.																																													
	__ x x	Device selection	05h	○	○	○																																								
	_ x _ _	For manufacturer setting	0h	▧	▧	▧																																								
	x _ _ _		0h	▧	▧	▧																																								
<p>Table 5.10 Selectable output devices</p> <table border="1"> <thead> <tr> <th>Setting value</th> <th>Output device</th> </tr> </thead> <tbody> <tr><td>__ 0 0</td><td>Always off</td></tr> <tr><td>__ 0 2</td><td>RD (Ready)</td></tr> <tr><td>__ 0 3</td><td>ALM (Malfunction)</td></tr> <tr><td>__ 0 4</td><td>INP (In-position)</td></tr> <tr><td>__ 0 5</td><td>MBR (Electromagnetic brake interlock)</td></tr> <tr><td>__ 0 6</td><td>DB (Dynamic brake interlock)</td></tr> <tr><td>__ 0 7</td><td>TLC (Limiting torque)</td></tr> <tr><td>__ 0 8</td><td>WNG (Warning)</td></tr> <tr><td>__ 0 9</td><td>BWNG (Battery warning)</td></tr> <tr><td>__ 0 A</td><td>SA (Speed reached)</td></tr> <tr><td>__ 0 B</td><td>VLC (Limiting speed)</td></tr> <tr><td>__ 0 C</td><td>ZSP (Zero speed detection)</td></tr> <tr><td>__ 0 F</td><td>CDPS (Variable gain selection)</td></tr> <tr><td>__ 1 0</td><td>CLDS (During fully closed loop control)</td></tr> <tr><td>__ 1 1</td><td>ABSV (Absolute position undetermined)</td></tr> <tr><td>__ 1 7</td><td>MTTR (During tough drive)</td></tr> <tr><td>__ 2 1</td><td>DOA (General-purpose output A) (Note)</td></tr> <tr><td>__ 2 2</td><td>DOB (General-purpose output B) (Note)</td></tr> <tr><td>__ 2 3</td><td>DOC (General-purpose output C) (Note)</td></tr> </tbody> </table>							Setting value	Output device	__ 0 0	Always off	__ 0 2	RD (Ready)	__ 0 3	ALM (Malfunction)	__ 0 4	INP (In-position)	__ 0 5	MBR (Electromagnetic brake interlock)	__ 0 6	DB (Dynamic brake interlock)	__ 0 7	TLC (Limiting torque)	__ 0 8	WNG (Warning)	__ 0 9	BWNG (Battery warning)	__ 0 A	SA (Speed reached)	__ 0 B	VLC (Limiting speed)	__ 0 C	ZSP (Zero speed detection)	__ 0 F	CDPS (Variable gain selection)	__ 1 0	CLDS (During fully closed loop control)	__ 1 1	ABSV (Absolute position undetermined)	__ 1 7	MTTR (During tough drive)	__ 2 1	DOA (General-purpose output A) (Note)	__ 2 2	DOB (General-purpose output B) (Note)	__ 2 3	DOC (General-purpose output C) (Note)
Setting value	Output device																																													
__ 0 0	Always off																																													
__ 0 2	RD (Ready)																																													
__ 0 3	ALM (Malfunction)																																													
__ 0 4	INP (In-position)																																													
__ 0 5	MBR (Electromagnetic brake interlock)																																													
__ 0 6	DB (Dynamic brake interlock)																																													
__ 0 7	TLC (Limiting torque)																																													
__ 0 8	WNG (Warning)																																													
__ 0 9	BWNG (Battery warning)																																													
__ 0 A	SA (Speed reached)																																													
__ 0 B	VLC (Limiting speed)																																													
__ 0 C	ZSP (Zero speed detection)																																													
__ 0 F	CDPS (Variable gain selection)																																													
__ 1 0	CLDS (During fully closed loop control)																																													
__ 1 1	ABSV (Absolute position undetermined)																																													
__ 1 7	MTTR (During tough drive)																																													
__ 2 1	DOA (General-purpose output A) (Note)																																													
__ 2 2	DOB (General-purpose output B) (Note)																																													
__ 2 3	DOC (General-purpose output C) (Note)																																													
PD08 *DO2 Output device selection 2	Any output device can be assigned to the CN3-9 pin. INP (In-position) is assigned as the initial value. Refer to table 5.10 in [Pr. PD07] for settings.																																													
	__ x x	Device selection	04h	○	○	○																																								
	_ x _ _	For manufacturer setting	0h	▧	▧	▧																																								
	x _ _ _		0h	▧	▧	▧																																								
PD09 *DO3 Output device selection 3	Any output device can be assigned to the CN3-15 pin. ALM (Malfunction) is assigned as the initial value. Refer to table 5.10 in [Pr. PD07] for settings.																																													
	__ x x	Device selection	03h	○	○	○																																								
	_ x _ _	For manufacturer setting	0h	▧	▧	▧																																								
	x _ _ _		0h	▧	▧	▧																																								

5. PARAMETERS

No./ symbol/name	Setting digit	Function	Initial value [unit]	Network								
				ECT	EIP	PNT						
PD11 *DIF Input filter setting	Select a filter for the input signal.											
	___x	Input signal filter selection If external input signal causes chattering due to noise, etc., input filter is used to suppress it. 0: None 1: 0.888 [ms] 2: 1.777 [ms] 3: 2.666 [ms] 4: 3.555 [ms]	4h	○	○	○						
	__x__	For manufacturer setting	0h	/	/	/						
	_x__		0h	/	/	/						
PD12 *DOP1 Function selection D-1	___x	For manufacturer setting	1h	/	/	/						
	__x__		0h	/	/	/						
	_x__		1h	/	/	/						
	x___	Servo motor thermistor enabled/disabled selection 0: Enabled 1: Disabled The setting in this digit will be disabled when you use a servo motor without thermistor.	0h	○	○	○						
PD13 *DOP2 Function selection D-2	___x	For manufacturer setting	0h	/	/	/						
	__x__		0h	/	/	/						
	_x__	INP (In-position) on condition selection Select a condition for turning on INP (In-position). 0: Within the in-position range 1: Within the in-position range and at the completion of command output	0h	○	○	○						
	x___	For manufacturer setting	0h	/	/	/						
PD14 *DOP3 Function selection D-3	___x	For manufacturer setting	0h	/	/	/						
	__x__	Selection of output device at warning occurrence Select WNG (Warning) and ALM (Malfunction) output status at warning occurrence. Driver output	0h	○	○	○						
	<table border="1" style="width: 100%; border-collapse: collapse;"> <thead> <tr> <th style="width: 15%;">Setting value</th> <th style="width: 85%;">(Note 1) Device status</th> </tr> </thead> <tbody> <tr> <td style="text-align: center;">0</td> <td> <div style="display: flex; justify-content: space-between;"> <div style="width: 15%;"> WNG 1 0 ALM 1 0 </div> <div style="width: 85%;"> <p style="text-align: center;">Warning occurrence</p> </div> </div> </td> </tr> <tr> <td style="text-align: center;">1</td> <td> <div style="display: flex; justify-content: space-between;"> <div style="width: 15%;"> WNG 1 0 ALM 1 0 </div> <div style="width: 85%;"> <p style="text-align: center;">Warning occurrence (Note 2)</p> </div> </div> </td> </tr> </tbody> </table> <p>Note 1. 0: Off 1: On 2. Although ALM is turned off upon occurrence of the warning, the forced stop deceleration is performed.</p>		Setting value	(Note 1) Device status	0	<div style="display: flex; justify-content: space-between;"> <div style="width: 15%;"> WNG 1 0 ALM 1 0 </div> <div style="width: 85%;"> <p style="text-align: center;">Warning occurrence</p> </div> </div>	1	<div style="display: flex; justify-content: space-between;"> <div style="width: 15%;"> WNG 1 0 ALM 1 0 </div> <div style="width: 85%;"> <p style="text-align: center;">Warning occurrence (Note 2)</p> </div> </div>				
	Setting value	(Note 1) Device status										
0	<div style="display: flex; justify-content: space-between;"> <div style="width: 15%;"> WNG 1 0 ALM 1 0 </div> <div style="width: 85%;"> <p style="text-align: center;">Warning occurrence</p> </div> </div>											
1	<div style="display: flex; justify-content: space-between;"> <div style="width: 15%;"> WNG 1 0 ALM 1 0 </div> <div style="width: 85%;"> <p style="text-align: center;">Warning occurrence (Note 2)</p> </div> </div>											
_x__	For manufacturer setting	0h	/	/	/							
x___		0h	/	/	/							

5. PARAMETERS

No./ symbol/name	Setting digit	Function	Initial value [unit]	Network		
				ECT	EIP	PNT
PD37 *TPOP Touch probe function selection	___x	Touch probe higher precision selection Latches the rising of TPR2 correctly, and detects it with an accuracy of 2 μs. 0: Disabled 1: Enabled When "Enabled" is selected, encoder output pulses are disabled.	0h	<input type="radio"/>	<input type="radio"/>	<input type="radio"/>
	__x_	For manufacturer setting	0h	/	/	/
	_x__		0h	/	/	/
	x___		0h	/	/	/
PD38 *TPR1 Touch probe selection 1	__xx	Input signal function selection Select an input device to be assigned to the CN3-10 pin. 2C: TPR1 (touch probe 1) 2E: ST (operation start-up)	2Ch	/	<input type="radio"/>	/
	_x__	For manufacturer setting	0h	/	/	/
	x___		0h	/	/	/

5. PARAMETERS

5.2.5 Extension setting 2 parameters ([Pr. PE__])

No./ symbol/name	Setting digit	Function	Initial value [unit]	Network		
				ECT	EIP	PNT
PE01 **FCT1 Fully closed loop function selection 1	___x	Fully closed loop function selection Do not change this value.	0h	<input type="radio"/>		
	__x_	For manufacturer setting	0h			
	_x__		0h			
	x___		0h			
PE03 *FCT2 Fully closed loop function selection 2	___x	Fully closed loop control error detection function selection Do not change this value.	3h	<input type="radio"/>	<input type="radio"/>	<input type="radio"/>
	__x_	Position deviation error detection system selection Do not change this value.	0h	<input type="radio"/>	<input type="radio"/>	<input type="radio"/>
	_x__	For manufacturer setting	0h			
	x___	Fully closed loop control error reset selection Do not change this value.	0h	<input type="radio"/>	<input type="radio"/>	<input type="radio"/>

5. PARAMETERS

No./ symbol/name	Setting digit	Function	Initial value [unit]	Network		
				ECT	EIP	PNT
PE04 **FBN Fully closed loop control - Feedback pulse electronic gear 1 - Numerator		Do not change this value.	1	<input type="radio"/>	<input type="radio"/>	<input type="radio"/>
PE05 **FBD Fully closed loop control - Feedback pulse electronic gear 1 - Denominator		Do not change this value.	1	<input type="radio"/>	<input type="radio"/>	<input type="radio"/>
PE06 BC1 Fully closed loop control - Speed deviation error detection level		Do not change this value.	400 [r/min]	<input type="radio"/>	<input type="radio"/>	<input type="radio"/>
PE07 BC2 Fully closed loop control - Position deviation error detection level		Do not change this value.	100 [kpulse]	<input type="radio"/>	<input type="radio"/>	<input type="radio"/>
PE08 DUF Fully closed loop dual feedback filter		Do not change this value.	10 [rad/s]	<input type="radio"/>	<input type="radio"/>	<input type="radio"/>
PE10 FCT3 Fully closed loop function selection 3	__ _ x __ x _ _ x _ _ x _ _ _	For manufacturer setting Fully closed loop control - Position deviation error detection level - Unit selection Do not change this value. For manufacturer setting	0h 0h 0h 0h	<input type="radio"/>	<input type="radio"/>	<input type="radio"/>
PE34 **FBN2 Fully closed loop control - Feedback pulse electronic gear 2 - Numerator		Do not change this value.	1	<input type="radio"/>	<input type="radio"/>	<input type="radio"/>

5. PARAMETERS

No./ symbol/name	Setting digit	Function	Initial value [unit]	Network		
				ECT	EIP	PNT
PE35 **FBD2 Fully closed loop control - Feedback pulse electronic gear 2 - Denominator		Do not change this value.	1	<input type="radio"/>	<input type="radio"/>	<input type="radio"/>
PE41 EOP3 Function selection E-3	--- x	Robust filter selection 0: Disabled 1: Enabled When "Enabled" is set, the machine resonance suppression filter 5 that is set in [Pr. PB51] is not available.	0h	<input type="radio"/>	<input type="radio"/>	<input type="radio"/>
	-- x --	For manufacturer setting	0h	<input type="checkbox"/>	<input type="checkbox"/>	<input type="checkbox"/>
	- x ---		0h	<input type="checkbox"/>	<input type="checkbox"/>	<input type="checkbox"/>
	x ----		0h	<input type="checkbox"/>	<input type="checkbox"/>	<input type="checkbox"/>
PE44 LMCP Lost motion compensation positive-side compensation value selection		Set the lost motion compensation for when reverse rotation (CW) switches to forward rotation (CCW) in increments of 0.01% assuming the rated torque as 100%. Setting range: 0 to 30000	0 [0.01%]	<input type="radio"/>	<input type="radio"/>	<input type="radio"/>
PE45 LMCN Lost motion compensation negative-side compensation value selection		Set the lost motion compensation for when forward rotation (CCW) switches to reverse rotation (CW) in increments of 0.01% assuming the rated torque as 100%. Setting range: 0 to 30000	0 [0.01%]	<input type="radio"/>	<input type="radio"/>	<input type="radio"/>
PE46 LMFLT Lost motion filter setting		Set the time constant of the lost motion compensation filter in increments of 0.1 ms. If the time constant is "0", the torque is compensated with the value set in [Pr. PE44] and [Pr. PE45]. If the time constant is other than "0", the torque is compensated with the high-pass filter output value of the set time constant, and the lost motion compensation will continue. Setting range: 0 to 30000	0 [0.1 ms]	<input type="radio"/>	<input type="radio"/>	<input type="radio"/>

5. PARAMETERS

No./ symbol/name	Setting digit	Function	Initial value [unit]	Network		
				ECT	EIP	PNT
PE47 TOF Torque offset		Set this when canceling unbalanced torque of vertical axis. Set this assuming the rated torque of the servo motor as 100%. The torque offset does not need to be set for a machine where the unbalanced torque does not occur. The torque offset cannot be used for linear servo motors and direct drive motors. Set "0". The torque offset set with this parameter will be enabled in the position mode, velocity mode, and torque mode. Input commands assuming torque offset for the torque mode. Use this parameter when a dynamic change is not necessary in the torque offset. When a dynamic change in the torque offset is required during the operation, use "Torque offset (Index: 60B2h)". Setting range: -10000 to 10000	0 [0.01%]	<input type="radio"/>	<input type="radio"/>	<input type="radio"/>
		Set this when canceling unbalanced torque of vertical axis. Set this assuming the rated torque of the servo motor as 100%. The torque offset does not need to be set for a machine where the unbalanced torque does not occur. The torque offset cannot be used for linear servo motors and direct drive motors. Set "0". The torque offset set with this parameter will be enabled in the position mode, velocity mode, and torque mode. Input commands assuming torque offset for the torque mode. Setting range: -10000 to 10000	0 [0.01%]	<input type="radio"/>	<input type="radio"/>	<input type="radio"/>
PE48 *LMOP Lost motion compensation function selection	___x	Lost motion compensation selection 0: Disabled 1: Enabled	0h	<input type="radio"/>	<input type="radio"/>	<input type="radio"/>
	__x_	Unit setting of lost motion compensation non-sensitive band 0: 1 pulse unit 1: 1 kpulse unit	0h	<input type="radio"/>	<input type="radio"/>	<input type="radio"/>
	_x__	For manufacturer setting	0h	<input type="radio"/>	<input type="radio"/>	<input type="radio"/>
	x___		0h	<input type="radio"/>	<input type="radio"/>	<input type="radio"/>
PE49 LMCD Lost motion compensation timing		Set the lost motion compensation timing in increments of 0.1 ms. You can delay the timing to perform the lost motion compensation for the set time. Setting range: 0 to 30000	0 [0.1 ms]	<input type="radio"/>	<input type="radio"/>	<input type="radio"/>
PE50 LMCT Lost motion compensation non-sensitive band		Set the lost motion compensation non-sensitive band. When the fluctuation of droop pulses equals to or less than the setting value, the speed will be 0. Setting can be changed in [Pr. PE48]. Set the parameter per encoder unit. Setting range: 0 to 65535	0 [pulse]/ [kpulse]	<input type="radio"/>	<input type="radio"/>	<input type="radio"/>

5. PARAMETERS

5.2.6 Extension setting 3 parameters ([Pr. PF__])

No./ symbol/name	Setting digit	Function	Initial value [unit]	Network															
				ECT	EIP	PNT													
PF06 *FOP5 Function selection F-5	___x	Electronic dynamic brake selection 0: Automatic (Only valid for servo motors of 100 to 400W) 2: Disabled	0h	<input type="radio"/>	<input type="radio"/>	<input type="radio"/>													
	__x_	For manufacturer setting	0h	<input type="checkbox"/>	<input type="checkbox"/>	<input type="checkbox"/>													
	_x__		0h	<input type="checkbox"/>	<input type="checkbox"/>	<input type="checkbox"/>													
	x___		0h	<input type="checkbox"/>	<input type="checkbox"/>	<input type="checkbox"/>													
PF12 DBT Electronic dynamic brake operating time		Set an operating time for the electronic dynamic brake. Setting range: 0 to 10000	2000 [ms]	<input type="radio"/>	<input type="radio"/>	<input type="radio"/>													
PF18 **STOD STO diagnosis error detection time		Set the time from when the error of the STO input or STO circuit is detected until the occurrence of [AL. 68.1 Mismatched STO signal error]. Setting "0" will not trigger [AL. 68.1 Mismatched STO signal error]. The safety level depends on the setting values as follows. <table border="1" style="width: 100%; border-collapse: collapse;"> <thead> <tr> <th>Setting value</th> <th>STO input diagnosis by TOFB output</th> <th>Safety level</th> </tr> </thead> <tbody> <tr> <td rowspan="2">0</td> <td>Execute</td> <td>EN ISO 13849-1 Category 3 PL d, IEC 61508 SIL 2, EN 62061 SIL CL2</td> </tr> <tr> <td>Not execute</td> <td>EN 62061 SIL CL2</td> </tr> <tr> <td rowspan="2">1 to 60</td> <td>Execute</td> <td>EN ISO 13849-1 Category 3 PL e, IEC 61508 SIL 3, EN 62061 SIL CL3</td> </tr> <tr> <td>Not execute</td> <td>EN ISO 13849-1 Category 3 PL d, IEC 61508 SIL 2, EN 62061 SIL CL2</td> </tr> </tbody> </table> When the short-circuit connector is connected to the CN8 connector, set "0" in the parameter. When MR-D30 functional safety unit is used, the parameter is not available. For safety levels at the time of using MR-D30, refer to "MR-D30 Instruction Manual".	Setting value	STO input diagnosis by TOFB output	Safety level	0	Execute	EN ISO 13849-1 Category 3 PL d, IEC 61508 SIL 2, EN 62061 SIL CL2	Not execute	EN 62061 SIL CL2	1 to 60	Execute	EN ISO 13849-1 Category 3 PL e, IEC 61508 SIL 3, EN 62061 SIL CL3	Not execute	EN ISO 13849-1 Category 3 PL d, IEC 61508 SIL 2, EN 62061 SIL CL2	10 [s]	<input type="radio"/>	<input type="radio"/>	<input type="radio"/>
Setting value	STO input diagnosis by TOFB output	Safety level																	
0	Execute	EN ISO 13849-1 Category 3 PL d, IEC 61508 SIL 2, EN 62061 SIL CL2																	
	Not execute	EN 62061 SIL CL2																	
1 to 60	Execute	EN ISO 13849-1 Category 3 PL e, IEC 61508 SIL 3, EN 62061 SIL CL3																	
	Not execute	EN ISO 13849-1 Category 3 PL d, IEC 61508 SIL 2, EN 62061 SIL CL2																	
PF21 DRT Drive recorder switching time setting		Set a drive recorder switching time. When a USB communication is cut during using a graph function, the function will be changed to the drive recorder function after the setting time of this parameter. When a value from "1" to "32767" is set, the function will be switched to the drive recorder function after the set time. However, when "0" is set, it will be switched after 600 s. When "-1" is set, the drive recorder function is disabled. Setting range: -1 to 32767	0 [s]	<input type="radio"/>	<input type="radio"/>	<input type="radio"/>													

5. PARAMETERS

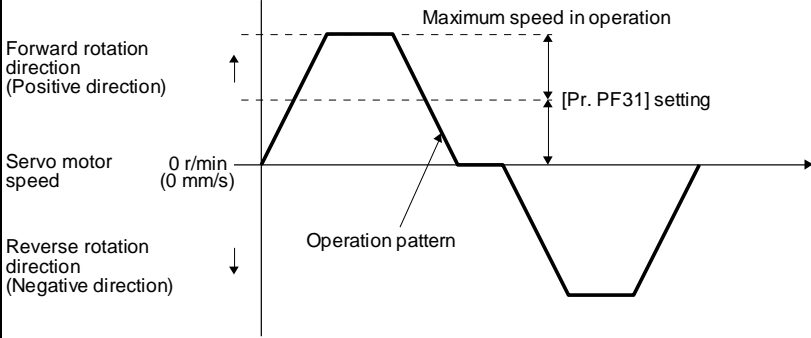
No./ symbol/name	Setting digit	Function	Initial value [unit]	Network		
				ECT	EIP	PNT
PF23 OSCL1 Vibration tough drive - Oscillation detection level		Set a filter readjustment sensitivity of [Pr. PB13 Machine resonance suppression filter 1] and [Pr. PB15 Machine resonance suppression filter 2] while the vibration tough drive is enabled. Note that setting "0" will be 50%. Example: When you set "50" to the parameter, the filter will be readjusted at the time of 50% or more oscillation level. Setting range: 0 to 100	50 [%]	<input type="radio"/>	<input type="radio"/>	<input type="radio"/>
PF24 *OSCL2 Vibration tough drive function selection	__ _ x	Oscillation detection alarm selection Select whether to generate an alarm or a warning when an oscillation continues at a filter readjustment sensitivity level of [Pr. PF23]. The setting is always enabled regardless of the vibration tough drive in [Pr. PA20]. 0: [AL. 54 Oscillation detection] will occur at oscillation detection. 1: [AL. F3.1 Oscillation detection warning] will occur at oscillation detection. 2: Oscillation detection function disabled	0h	<input type="radio"/>	<input type="radio"/>	<input type="radio"/>
	_ _ x _	For manufacturer setting	0h	<input type="checkbox"/>	<input type="checkbox"/>	<input type="checkbox"/>
	_ x _ _		0h	<input type="checkbox"/>	<input type="checkbox"/>	<input type="checkbox"/>
	x _ _ _		0h	<input type="checkbox"/>	<input type="checkbox"/>	<input type="checkbox"/>
PF25 CVAT SEMI-F47 function - Instantaneous power failure detection time		Set the time of the [AL. 10.1 Voltage drop in the control circuit power] occurrence. To comply with SEMI-F47 standard, it is unnecessary to change the initial value (200 ms). When the instantaneous power failure time exceeds 200 ms, and the instantaneous power failure voltage is less than 70% of the rated input voltage, the power may be normally turned off even if a value larger than 200 ms is set in the parameter. To disable the parameter setting value, select "Disabled (_ 0 _ _)" of "SEMI-F47 function selection" in [Pr. PA20]. Setting range: 30 to 500	200 [ms]	<input type="radio"/>	<input type="radio"/>	<input type="radio"/>
PF31 FRIC Machine diagnosis function - Friction judgment speed		Set a servo motor speed that divides a friction estimation area into high and low during the friction estimation process of the machine diagnosis. However, setting "0" will be the value half of the rated speed. When your operation pattern is under rated speed, we recommend that you set half value to the maximum speed with this. 	0 [r/min]/ [mm/s]	<input type="radio"/>	<input type="radio"/>	<input type="radio"/>
		Setting range: 0 to instantaneous permissible speed				

5. PARAMETERS

5.2.7 Positioning control parameters ([Pr. PT_ _])

No./ symbol/name	Setting digit	Function	Initial value [unit]	Network		
				ECT	EIP	PNT
PT01 **CTY	___x	For manufacturer setting	0h			
	__x_		0h			
Command mode selection	_x__	Position data unit 0: mm 1: inch 2: degree 3: pulse This function will be enabled in the profile mode and point table method. The unit is [pulse] in the cyclic synchronous mode. In the cyclic synchronous mode, setting other values than "3" will trigger [AL. 37]. If "2" is set in the point table method, [AL. 37] will occur.	3h	○	○	○
	x___	For manufacturer setting	0h			

5. PARAMETERS

No./ symbol/name	Setting digit	Function	Initial value [unit]	Network		
				ECT	EIP	PNT
PT03 *FTY Feeding function selection	___x	Feed length multiplication [STM] 0: x 1 1: x 10 2: x 100 3: x 1000 This function will be enabled in the profile mode and point table method. This function will be disabled when [degree] or [pulse] of "Position data unit" is set in [Pr. PT01].	0h	<input type="radio"/>	<input type="radio"/>	<input type="radio"/>
	__x_	For manufacturer setting	0h	<input type="checkbox"/>	<input type="checkbox"/>	<input type="checkbox"/>
	_x__	Shortest rotation selection per degree 0: Rotation direction specifying 1: Shortest rotation 2: Address decreasing direction 3: Address increasing direction This function will be enabled in the profile mode. Setting a value immediately enables this parameter. This parameter corresponds to "Positioning option code (Index: 60F2h)". When this parameter is mapped for the PDO communication, the value written with Setup software (MR Configurator2™) is overwritten with the upper side. Thus, do not write a value with Setup software (MR Configurator2™).	0h	<input type="radio"/>	<input type="checkbox"/>	<input type="checkbox"/>
		Shortest rotation selection per degree 0: Rotation direction specifying 1: Shortest rotation 2: Address decreasing direction 3: Address increasing direction This function will be enabled in the profile mode. Setting a value immediately enables this parameter. This parameter corresponds to "Positioning option code (Class ID: 64h, Ins ID: 60F2h, Attr ID: 0)". When this parameter is mapped for the I/O communication, the value written with Setup software (MR Configurator2™) is overwritten with the upper side. Thus, do not write a value with Setup software (MR Configurator2™).	0h	<input type="checkbox"/>	<input type="radio"/>	<input type="checkbox"/>
		Shortest rotation selection per degree 0: Rotation direction specifying 1: Shortest rotation 2: Address decreasing direction 3: Address increasing direction This function will be enabled in the profile mode. Setting a value immediately enables this parameter. This parameter corresponds to "Positioning option code (PNU: 24818, Sub: 0)". When this parameter is mapped for the Process Data communication, the value written with Setup software (MR Configurator2™) is overwritten with the upper side. Thus, do not write a value with Setup software (MR Configurator2™).	0h	<input type="checkbox"/>	<input type="checkbox"/>	<input type="radio"/>
	x___	For manufacturer setting	0h	<input type="checkbox"/>	<input type="checkbox"/>	<input type="checkbox"/>

5. PARAMETERS

No./ symbol/name	Setting digit	Function	Initial value [unit]	Network		
				ECT	EIP	PNT
PT05 ZRF Home position return speed		<p>Set the servo motor speed for the home position return. The fractional portion of the parameter will be rounded down. The setting value will be clamped at the instantaneous permissible speed.</p> <p>This parameter corresponds to "Speed during search for switch (Index: 6099h, Sub: 1)". When this parameter is mapped for the PDO communication, the value written with Setup software (MR Configurator2™) is overwritten with the upper side. Thus, do not write a value with Setup software (MR Configurator2™).</p> <p>Setting range: 0.00 to 167772.15</p>	100.00 [r/min]/ [mm/s]	<input type="radio"/>		
		<p>Set the servo motor speed for the home position return. The fractional portion of the parameter will be rounded down. The setting value will be clamped at the instantaneous permissible speed.</p> <p>This parameter corresponds to "Speed during search for switch (Class ID: 64h, Ins ID: 6099h, Attr ID: 1)". When this parameter is mapped for the I/O communication, the value written with Setup software (MR Configurator2™) is overwritten with the upper side. Thus, do not write a value with Setup software (MR Configurator2™).</p> <p>Setting range: 0.00 to 167772.15</p>	100.00 [r/min]/ [mm/s]		<input type="radio"/>	
		<p>Set the servo motor speed for the home position return. The fractional portion of the parameter will be rounded down. The setting value will be clamped at the instantaneous permissible speed.</p> <p>This parameter corresponds to "Speed during search for switch (PNU: 24729, Sub: 0)". When this parameter is mapped for the Process Data communication, the value written with Setup software (MR Configurator2™) is overwritten with the upper side. Thus, do not write a value with Setup software (MR Configurator2™).</p> <p>Setting range: 0.00 to 167772.15</p>	100.00 [r/min]/ [mm/s]			<input type="radio"/>
PT06 CRF Creep speed		<p>Set a creep speed after proximity dog at home position return. The fractional portion of the parameter will be rounded down. The setting value will be clamped at the instantaneous permissible speed.</p> <p>This parameter corresponds to "Speed during search for zero (Index: 6099h, Sub: 2)". When this parameter is mapped for the PDO communication, the value written with Setup software (MR Configurator2™) is overwritten with the upper side. Thus, do not write a value with Setup software (MR Configurator2™).</p> <p>Setting range: 0.00 to 167772.15</p>	10.00 [r/min]/ [mm/s]	<input type="radio"/>		
		<p>Set a creep speed after proximity dog at home position return. The fractional portion of the parameter will be rounded down. The setting value will be clamped at the instantaneous permissible speed.</p> <p>This parameter corresponds to "Speed during search for switch (Class ID: 64h, Ins ID: 6099h, Attr ID: 2)". When this parameter is mapped for the I/O communication, the value written with Setup software (MR Configurator2™) is overwritten with the upper side. Thus, do not write a value with Setup software (MR Configurator2™).</p> <p>Setting range: 0.00 to 167772.15</p>	10.00 [r/min]/ [mm/s]		<input type="radio"/>	
		<p>Set a creep speed after proximity dog at home position return. The fractional portion of the parameter will be rounded down. The setting value will be clamped at the instantaneous permissible speed.</p> <p>This parameter corresponds to "Speed during search for switch (PNU: 24729, Sub: 1)". When this parameter is mapped for the Process Data communication, the value written with Setup software (MR Configurator2™) is overwritten with the upper side. Thus, do not write a value with Setup software (MR Configurator2™).</p> <p>Setting range: 0.00 to 167772.15</p>	10.00 [r/min]/ [mm/s]			<input type="radio"/>

5. PARAMETERS

No./ symbol/name	Setting digit	Function	Initial value [unit]	Network		
				ECT	EIP	PNT
PT07 ZST Home position shift distance		<p>Set a shift distance from the Z-phase pulse detection position or the position that has been set by the travel distance after proximity dog in the encoder. Up to 22147483647 can be set with [Pr. PT69]. The unit will be as follows with the setting of [Pr. PA01].</p> <ul style="list-style-type: none"> In the cyclic synchronous mode The unit is [pulse]. In the profile mode and the point table method The unit can be changed to [μm], 10^{-4} [inch], 10^{-3} [degree] or [pulse] with the setting of [Pr. PT01]. In the indexer method It will be command unit [pulse]. (A load-side rotation expressed by the number of servo motor resolution pulses) Refer to the Function column of [Pr. PA10] for the command unit [pulse]. <p>Setting range: 0 to 65535</p>	0 Refer to Function column for unit.	<input type="radio"/>	<input type="radio"/>	<input type="radio"/>
PT09 DCT Travel distance after proximity dog		<p>Set a travel distance after proximity dog at home position return for the count type (front end detection, Z-phase reference) (Homing method -2, -34) and the following dog references.</p> <ul style="list-style-type: none"> Dog type rear end reference home position return (Homing method -6, -38) Count type front end reference home position return (Homing method -7, -39) Dog type front end reference home position return (Homing method -10, -42) Homing without index pulse (Homing method 19, 20, 21, 22, 23, 24, 27, 28) <p>Up to 2147483647 can be set with the setting of [Pr. PT71]. This function will be enabled in the cyclic synchronous mode, profile mode and point table method. The unit can be changed to 10^{STM} [μm], $10^{(\text{STM}-4)}$ [inch], 10^{-3} [degree] or [pulse] with the setting of [Pr. PT01]. Setting range: 0 to 65535</p>	0 Refer to Function column for unit.	<input type="radio"/>	<input type="radio"/>	<input type="radio"/>
PT10 ZTM Stopper type home position return stopper time		<p>Set a time from a moving part touches the stopper and torques reaches to the torque limit of [Pr. PT11 Stopper type home position return - Torque limit value] to a home position is set for the stopper type home position return. This function will be enabled in the cyclic synchronous mode, profile mode and point table method. Setting range: 5 to 1000</p>	100 [ms]	<input type="radio"/>	<input type="radio"/>	<input type="radio"/>
PT11 ZTT Stopper type home position return torque limit value		<p>Set a torque limit value with [%] to the rated torque at stopper type home position return. This function will be enabled in the cyclic synchronous mode, profile mode and point table method. Setting range: 0.1 to 100.0</p>	15.0 [%]	<input type="radio"/>	<input type="radio"/>	<input type="radio"/>
PT12 CRP Rough match output range		<p>Set a range of the command remaining distance which outputs S_CPO (Rough match). This function will be enabled in the point table method and the indexer method. The unit will be as follows, depending on the control mode.</p> <ul style="list-style-type: none"> In the point table method The unit can be changed to 10^{STM} [μm], $10^{(\text{STM}-4)}$ [inch], 10^{-3} [degree] or [pulse] with the setting of [Pr. PT01]. In the indexer method It will be command unit [pulse]. (A load-side rotation expressed by the number of servo motor resolution pulses) Refer to the Function column of [Pr. PA10] for the command unit [pulse]. <p>Setting range: 0 to 65535</p>	0 Refer to Function column for unit.	<input type="radio"/>	<input type="radio"/>	<input type="radio"/>

5. PARAMETERS

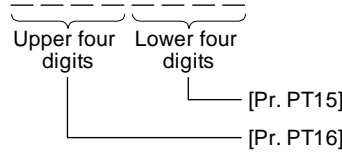
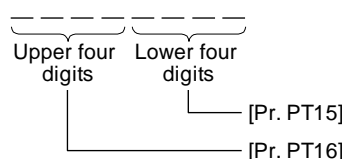
No./ symbol/name	Setting digit	Function	Initial value [unit]	Network		
				ECT	EIP	PNT
PT15 LMPL Software limit + (lower four digits)		<p>Set an address increasing side of the software stroke limit. Upper and lower are a set. Set an address in hexadecimal.</p> <p>Setting address:</p>  <p style="text-align: right;">[Pr. PT15] [Pr. PT16]</p> <p>Setting an identical value for "Software limit -" and this parameter will disable the software limit. (Refer to section 5.3.) When changing the setting with the parameter, change it during servo-off, in the homing mode (hm), velocity mode, or torque mode. In the position mode during servo-on, changing the setting in a certain order may trigger [AL. 35], [AL. 69], or [AL. 98]. This function will be enabled in the cyclic synchronous mode, profile mode and point table method. The unit can be changed to 10^{STM} [μm], 10^(STM-4) [inch], 10⁻³ [degree] or [pulse] according to the setting of [Pr. PT01].</p> <p>This parameter corresponds to "Max position limit (Index: 607Dh, Sub: 2)". When this parameter is mapped for the PDO communication, the value written with Setup software (MR Configurator2™) is overwritten with the upper side. Thus, do not write a value with Setup software (MR Configurator2™).</p> <p>Setting range: 00000000h to FFFFFFFFh</p>	0000h Refer to Function column for unit.	○		
		<p>Set an address increasing side of the software stroke limit. Upper and lower are a set. Set an address in hexadecimal.</p> <p>Setting address:</p>  <p style="text-align: right;">[Pr. PT15] [Pr. PT16]</p> <p>Setting an identical value for "Software limit -" and this parameter will disable the software limit. (Refer to section 5.3.) When changing the setting with the parameter, change it during servo-off, in the homing mode (hm), velocity mode, or torque mode. In the position mode during servo-on, changing the setting in a certain order may trigger [AL. 35], [AL. 69], or [AL. 98]. This function will be enabled in the profile mode. The unit can be changed to 10^{STM} [μm], 10^(STM-4) [inch], 10⁻³ [degree] or [pulse] according to the setting of [Pr. PT01].</p> <p>This parameter corresponds to "Max position limit (Class ID: 64h, Ins ID: 607Dh, Attr ID: 2)". When this parameter is mapped for the I/O communication, the value written with Setup software (MR Configurator2™) is overwritten with the upper side. Thus, do not write a value with Setup software (MR Configurator2™).</p> <p>Setting range: 00000000h to FFFFFFFFh</p>	0000h Refer to Function column for unit.	○		

5. PARAMETERS

No./ symbol/name	Setting digit	Function	Initial value [unit]	Network		
				ECT	EIP	PNT
PT15 LMPL Software limit + (lower four digits)		<p>Set an address increasing side of the software stroke limit. Upper and lower are a set. Set an address in hexadecimal.</p> <p>Setting address:</p> <div style="text-align: center;"> </div> <p>Setting an identical value for "Software limit -" and this parameter will disable the software limit. (Refer to section 5.3.) When changing the setting with the parameter, change it during servo-off, in the homing mode (hm), velocity mode, or torque mode. In the position mode during servo-on, changing the setting in a certain order may trigger [AL. 35], [AL. 69], or [AL. 98]. This function will be enabled in the profile mode and point table method. The unit can be changed to 10^{STM} [μm], $10^{\text{STM}-4}$ [inch], 10^{-3} [degree] or [pulse] according to the setting of [Pr. PT01].</p> <p>This parameter corresponds to "Max position limit (PNU: 24701, Sub: 1)". When this parameter is mapped for the Process Data communication, the value written with Setup software (MR Configurator2™) is overwritten with the upper side. Thus, do not write a value with Setup software (MR Configurator2™).</p> <p>Setting range: 00000000h to FFFFFFFFh</p>	0000h Refer to Function column for unit.			○
PT16 LMPH Software limit + (upper four digits)		<p>Set an address increasing side of the software stroke limit. Upper and lower are a set. Refer to [Pr. PT15] for details. The unit can be changed to 10^{STM} [μm], $10^{\text{STM}-4}$ [inch], 10^{-3} [degree] or [pulse] according to the setting of [Pr. PT01].</p>	0000h Refer to Function column for unit.	○	○	○

5. PARAMETERS

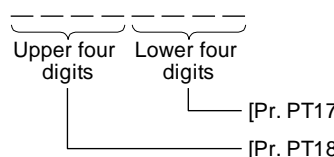
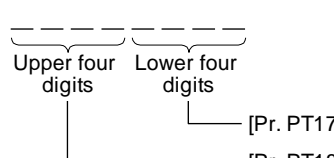
No./ symbol/name	Setting digit	Function	Initial value [unit]	Network		
				ECT	EIP	PNT
PT17 LMNL Software limit - (lower four digits)		<p>Set an address decreasing side of the software stroke limit. Upper and lower are a set. Set an address in hexadecimal.</p> <p>Setting address:</p>  <p>Setting a same value with "Software limit +" will disable the software stroke limit. (Refer to section 5.3.)</p> <p>When changing the setting with the parameter, change it during servo-off, in the homing mode (hm), velocity mode, or torque mode.</p> <p>In the position mode during servo-on, changing the setting in a certain order may trigger [AL. 35], [AL. 69], or [AL. 98].</p> <p>This function will be enabled in the cyclic synchronous mode, profile mode and point table method.</p> <p>The unit can be changed to 10^{STM} [μm], 10^(STM-4) [inch], 10⁻³ [degree] or [pulse] according to the setting of [Pr. PT01].</p> <p>This parameter corresponds to "Min position limit (Index: 607Dh, Sub: 1)". When this parameter is mapped for the PDO communication, the value written with Setup software (MR Configurator2™) is overwritten with the upper side. Thus, do not write a value with Setup software (MR Configurator2™).</p> <p>Setting range: 00000000h to FFFFFFFFh</p>	0000h Refer to Function column for unit.	<input type="radio"/>		
		<p>Set an address decreasing side of the software stroke limit. Upper and lower are a set. Set an address in hexadecimal.</p> <p>Setting address:</p>  <p>Setting a same value with "Software limit +" will disable the software stroke limit. (Refer to section 5.3.)</p> <p>When changing the setting with the parameter, change it during servo-off, in the homing mode (hm), velocity mode, or torque mode.</p> <p>In the position mode during servo-on, changing the setting in a certain order may trigger [AL. 35], [AL. 69], or [AL. 98].</p> <p>This function will be enabled in the profile mode.</p> <p>The unit can be changed to 10^{STM} [μm], 10^(STM-4) [inch], 10⁻³ [degree] or [pulse] according to the setting of [Pr. PT01].</p> <p>This parameter corresponds to "Min position limit (Class ID: 64h, Ins ID: 607Dh, Attr ID: 1)". When this parameter is mapped for the I/O communication, the value written with Setup software (MR Configurator2™) is overwritten with the upper side. Thus, do not write a value with Setup software (MR Configurator2™).</p> <p>Setting range: 00000000h to FFFFFFFFh</p>	0000h Refer to Function column for unit.		<input type="radio"/>	

5. PARAMETERS

No./ symbol/name	Setting digit	Function	Initial value [unit]	Network		
				ECT	EIP	PNT
PT17 LMNL Software limit - (lower four digits)		<p>Set an address decreasing side of the software stroke limit. Upper and lower are a set. Set an address in hexadecimal.</p> <p>Setting address:</p> <div style="text-align: center;"> </div> <p>[Pr. PT17] [Pr. PT18]</p> <p>Setting a same value with "Software limit +" will disable the software stroke limit. (Refer to section 5.3.)</p> <p>When changing the setting with the parameter, change it during servo-off, in the homing mode (hm), velocity mode, or torque mode.</p> <p>In the position mode during servo-on, changing the setting in a certain order may trigger [AL. 35], [AL. 69], or [AL. 98].</p> <p>This function will be enabled in the profile mode and point table method.</p> <p>The unit can be changed to 10^{STM} [μm], $10^{\text{STM-4}}$ [inch], 10^{-3} [degree] or [pulse] according to the setting of [Pr. PT01].</p> <p>This parameter corresponds to "Min position limit (PNU: 24701, Sub: 0)". When this parameter is mapped for the Process Data communication, the value written with Setup software (MR Configurator2™) is overwritten with the upper side. Thus, do not write a value with Setup software (MR Configurator2™).</p> <p>Setting range: 00000000h to FFFFFFFFh</p>	0000h Refer to Function column for unit.			○
PT18 LMNH Software limit - (upper four digits)		<p>Set an address decreasing side of the software stroke limit. Upper and lower are a set. Refer to [Pr. PT17] for details. The unit can be changed to 10^{STM} [μm], $10^{\text{STM-4}}$ [inch], 10^{-3} [degree] or [pulse] according to the setting of [Pr. PT01].</p>	0000h Refer to Function column for unit.	○	○	○
PT19 *LPPL Position range output address + (lower four digits)		<p>Set an address increasing side of the position range output address. Upper and lower are a set. Set a range which S_POT (Position range) turns on with [Pr. PT19] to [Pr. PT22].</p> <p>Setting address:</p> <div style="text-align: center;"> </div> <p>[Pr. PT19] [Pr. PT20]</p>	0000h Refer to Function column for unit.	○		○
PT20 *LPPH Position range output address + (upper four digits)		<p>This function will be enabled in the point table method. The unit can be changed to 10^{STM} [μm], $10^{\text{STM-4}}$ [inch], 10^{-3} [degree] or [pulse] with the setting of [Pr. PT01]. Setting range: 00000000h to FFFFFFFFh</p>	0000h Refer to Function column for unit.			

5. PARAMETERS

No./ symbol/name	Setting digit	Function	Initial value [unit]	Network		
				ECT	EIP	PNT
PT21 *LNPL Position range output address - (lower four digits)		Set an address decreasing side of the position range output address. Upper and lower are a set. Set a range which S_POT (Position range) turns on with [Pr. PT19] to [Pr. PT22]. Setting address: <div style="text-align: center; margin: 10px 0;"> </div>	0000h Refer to Function column for unit.	<input type="radio"/>	<input type="radio"/>	<input type="radio"/>
PT22 *LNPH Position range output address - (upper four digits)			0000h Refer to Function column for unit. This function will be enabled in the point table method. The unit can be changed to 10 ^{STM} [μm], 10 ^(STM-4) [inch], 10 ⁻³ [degree] or [pulse] with the setting of [Pr. PT01]. Setting range: 00000000h to FFFFFFFFh			
PT26 *TOP2 Function selection T-2	__ _ x	Electronic gear fraction clear selection 0: Disabled 1: Enabled Selecting "Enabled" will clear a fraction of the previous command by the electronic gear at start of the profile position mode (pp) and the point table mode (pt). This function will be enabled in the profile mode.	0h	<input type="radio"/>	<input type="radio"/>	<input type="radio"/>
	__ _ x _	For manufacturer setting	0h	<input type="checkbox"/>	<input type="checkbox"/>	<input type="checkbox"/>
	_ x _ _		0h	<input type="checkbox"/>	<input type="checkbox"/>	<input type="checkbox"/>
	x _ _ _		0h	<input type="checkbox"/>	<input type="checkbox"/>	<input type="checkbox"/>
PT27 *ODM Indexer method - Operation mode selection	__ _ x	For manufacturer setting	0h	<input type="checkbox"/>	<input type="checkbox"/>	<input type="checkbox"/>
	__ _ x _	Jog mode method selection 0: Station JOG operation 1: JOG operation This function will be enabled in the indexer method.	0h	<input type="radio"/>	<input type="radio"/>	<input type="radio"/>
	_ x _ _	For manufacturer setting	0h	<input type="checkbox"/>	<input type="checkbox"/>	<input type="checkbox"/>
	x _ _ _		0h	<input type="checkbox"/>	<input type="checkbox"/>	<input type="checkbox"/>
PT28 *STN Number of stations per rotation		Set the number of stations per rotation (number of indexer stations). Setting "2" or less will be "2". This function will be enabled in the indexer method. Setting range: 0 to 255	8 [Stations]	<input type="radio"/>	<input type="radio"/>	<input type="radio"/>

5. PARAMETERS

No./ symbol/name	Setting digit	Function	Initial value [unit]	Network																																																		
				ECT	EIP	PNT																																																
PT29 *TOP3 Function selection T-3	Set the DOG polarity.																																																					
	___x (HEX)	___x (BIN): DOG (Proximity dog) polarity selection - Profile mode, cyclic synchronous mode and point table method 0: Dog detection with off 1: Dog detection with on - Indexer method 0: Dog detection with on 1: Dog detection with off	0h	<input type="radio"/>	<input type="radio"/>	<input type="radio"/>																																																
	__x_	(BIN): For manufacturer setting																																																				
	_x__	(BIN): For manufacturer setting																																																				
	x___	(BIN): For manufacturer setting																																																				
	__x_	For manufacturer setting	0h																																																			
	_x__		0h																																																			
x___		0h																																																				
Convert the setting value into hexadecimal as follows. <div style="display: flex; align-items: center; margin-top: 10px;"> <div style="margin-right: 20px;"> <table border="1" style="border-collapse: collapse; text-align: center;"> <tr><td style="width: 20px; height: 20px;">0</td><td style="width: 20px; height: 20px;">0</td><td style="width: 20px; height: 20px;">0</td><td style="width: 20px; height: 20px;"> </td></tr> </table> </div> <div> <table border="1" style="border-collapse: collapse; text-align: center;"> <tr> <td style="width: 20px; height: 20px;"> </td> <td style="width: 20px; height: 20px;"> </td> <td style="width: 20px; height: 20px;"> </td> <td style="width: 20px; height: 20px;"> </td> <td style="width: 20px; height: 20px;"> </td> <td style="width: 20px; height: 20px;"> </td> </tr> <tr> <td colspan="5">Setting</td> <td>Initial value</td> </tr> <tr> <td colspan="5"></td> <td>BIN</td> <td>HEX</td> </tr> <tr> <td colspan="5">DOG (Proximity dog) polarity selection</td> <td>0</td> <td rowspan="4" style="vertical-align: middle; text-align: center;">0</td> </tr> <tr> <td colspan="5"></td> <td>0</td> </tr> <tr> <td colspan="5"></td> <td>0</td> </tr> <tr> <td colspan="5"></td> <td>0</td> </tr> </table> </div> </div>							0	0	0								Setting					Initial value						BIN	HEX	DOG (Proximity dog) polarity selection					0	0						0						0						0
0	0	0																																																				
Setting					Initial value																																																	
					BIN	HEX																																																
DOG (Proximity dog) polarity selection					0	0																																																
					0																																																	
					0																																																	
					0																																																	
PT34 **PDEF Point table default		Use this parameter when initializing point tables. A point table will be the following status by being initialized. Point table: All "0" Initialize the point tables with the following procedures: 1) Set "5001h" to this parameter. 2) Cycle the power of the driver. After the driver power is on, the initialization completes in about 20 s. After the initialization, the setting of this parameter will be "0000h" automatically. This function will be enabled in the point table method.	0000h	<input type="radio"/>		<input type="radio"/>																																																
PT35 *TOP5 Function selection T-5	___x	Superimposed synchronous control selection 0: Disabled 1: Enabled This function will be enabled in the profile mode. Setting "1" in other control modes will trigger [AL. 37 Parameter error]. This function will be enabled in the standard control mode. Setting "1" in other operation modes will trigger [AL. 37 Parameter error]. This function can be used when the scale measurement function is enabled. Setting "1" when the scale measurement function is disabled will trigger [AL. 37 Parameter error]. Setting "1" when the MR-D30 has been connected or the degree unit has been set will trigger [AL. 37 Parameter error]. For details, refer to chapter 18,19,20.	0h		<input type="radio"/>																																																	
	__x_	For manufacturer setting	0h																																																			
	_x__		0h																																																			
	x___		0h																																																			

5. PARAMETERS

No./ symbol/name	Setting digit	Function	Initial value [unit]	Network		
				ECT	EIP	PNT
PT39 INT Torque limit delay time		Set the delay time from outputting S_MEND (Travel completion) to enabling "Torque limit value2 (Index: 2D6Bh)". This function will be enabled in the indexer method. Setting range: 0 to 1000	100 [ms]	<input type="radio"/>	<input type="radio"/>	<input type="radio"/>
		Set the delay time from outputting S_MEND (Travel completion) to enabling "Torque limit value2 (PNU: 11627, Sub: 0)". This function will be enabled in the indexer method. Setting range: 0 to 1000	100 [ms]	<input type="radio"/>	<input type="radio"/>	<input type="radio"/>
PT40 *SZS Station home position shift distance		Set a station home position shift distance with encoder pulse unit at home position return. Setting this parameter enables to shift the station home position (station No. 0) to the position for home position return. The following shows cautions for the setting. <ul style="list-style-type: none"> The setting of the station home position shift is disabled at home position return. Cycling the power will enable the setting. When a home position shift distance is longer than the in-position range, INP/S_INP (In-position) will not be on regardless of cycle of the power after home position return. This function will be enabled in the indexer method. Setting range: -32000 to 32000	0 [pulse]	<input type="radio"/>	<input type="radio"/>	<input type="radio"/>
PT41 ORP Home position return inhibit function selection	___x	Home position return inhibit selection 0: Disabled (home position return allowed) 1: Enabled (home position return inhibited)	0h	<input type="radio"/>	<input type="radio"/>	<input type="radio"/>
	__x_	For manufacturer setting	0h	<input type="radio"/>	<input type="radio"/>	<input type="radio"/>
	_x__		0h	<input type="radio"/>	<input type="radio"/>	<input type="radio"/>
	x___		0h	<input type="radio"/>	<input type="radio"/>	<input type="radio"/>

5. PARAMETERS

No./ symbol/name	Setting digit	Function	Initial value [unit]	Network		
				ECT	EIP	PNT
PT45 HMM Home position return type		<p>Set a home position return type. Refer to the following table for details. If the home position return starts after a value other than the setting values is set, "Homing error" occurs and home position return cannot be executed. In the indexer method, if the home position return starts after values other than "-1", "-33", "-3", "35" and "37" are set, "Homing error" occurs and home position return cannot be executed.</p> <p>This parameter corresponds to "Homing method (Index: 6098h)". When this parameter is mapped for the PDO communication, the value written with Setup software (MR Configurator2™) is overwritten with the upper side. Thus, do not write a value with Setup software (MR Configurator2™).</p>	37	○		
		<p>Set a home position return type. Refer to the following table for details. If the home position return starts after a value other than the setting values is set, "Homing error" occurs and home position return cannot be executed.</p> <p>This parameter corresponds to "Homing method (Class ID: 64h, Ins ID: 6098h, Attr ID: 0)". When this parameter is mapped for the I/O communication, the value written with Setup software (MR Configurator2™) is overwritten with the upper side. Thus, do not write a value with Setup software (MR Configurator2™).</p>	37		○	
		<p>Set a home position return type. Refer to the following table for details. If the home position return starts after a value other than the setting values is set, "Homing error" occurs and home position return cannot be executed. In the indexer method, if the home position return starts after values other than "-1", "-33", "-3", "35" and "37" are set, "Homing error" occurs and home position return cannot be executed.</p> <p>This parameter corresponds to "Homing method (PNU: 24728, Sub: 0)". When this parameter is mapped for the Process Data communication, the value written with Setup software (MR Configurator2™) is overwritten with the upper side. Thus, do not write a value with Setup software (MR Configurator2™).</p>	37			○

5. PARAMETERS

No./ symbol/name	Setting digit	Function	Initial value [unit]	Network																																																																				
				ECT	EIP	PNT																																																																		
PT45 HMM Home position return type	<table border="1"> <thead> <tr> <th>Setting value</th> <th>Home position return direction</th> <th>How to execute home position return</th> </tr> </thead> <tbody> <tr><td>-1</td><td rowspan="11">Address increasing direction</td><td>Dog type (Rear end detection Zphase reference)/torque limit changing dog type (Front end detection, Zphase reference)</td></tr> <tr><td>-2</td><td>Count type (front end detection, Z-phase reference)</td></tr> <tr><td>-3</td><td>Data set type/torque limit changing data set type</td></tr> <tr><td>-4</td><td>Stopper type (stopper position reference)</td></tr> <tr><td>-6</td><td>Dog type (rear end detection, rear end reference)</td></tr> <tr><td>-7</td><td>Count type (front end detection, front end reference)</td></tr> <tr><td>-8</td><td>Dog cradle type</td></tr> <tr><td>-9</td><td>Dog type last Z-phase reference</td></tr> <tr><td>-10</td><td>Dog type front end reference</td></tr> <tr><td>-11</td><td>Dogless Z-phase reference</td></tr> </tbody> </table>	Setting value	Home position return direction	How to execute home position return	-1	Address increasing direction	Dog type (Rear end detection Zphase reference)/torque limit changing dog type (Front end detection, Zphase reference)	-2	Count type (front end detection, Z-phase reference)	-3	Data set type/torque limit changing data set type	-4	Stopper type (stopper position reference)	-6	Dog type (rear end detection, rear end reference)	-7	Count type (front end detection, front end reference)	-8	Dog cradle type	-9	Dog type last Z-phase reference	-10	Dog type front end reference	-11	Dogless Z-phase reference	<table border="1"> <thead> <tr> <th>Setting value</th> <th>Home position return direction</th> <th>How to execute home position return</th> </tr> </thead> <tbody> <tr><td>-33</td><td rowspan="11">Address decreasing direction</td><td>Dog type (Rear end detection Zphase reference)/torque limit changing dog type (Front end detection, Zphase reference)</td></tr> <tr><td>-34</td><td>Count type (front end detection, Z-phase reference)</td></tr> <tr><td>-36</td><td>Stopper type (stopper position reference)</td></tr> <tr><td>-38</td><td>Dog type (rear end detection, rear end reference)</td></tr> <tr><td>-39</td><td>Count type (front end detection, front end reference)</td></tr> <tr><td>-40</td><td>Dog cradle type</td></tr> <tr><td>-41</td><td>Dog type last Z-phase reference</td></tr> <tr><td>-42</td><td>Dog type front end reference</td></tr> <tr><td>-43</td><td>Dogless Z-phase reference</td></tr> </tbody> </table>	Setting value	Home position return direction	How to execute home position return	-33	Address decreasing direction	Dog type (Rear end detection Zphase reference)/torque limit changing dog type (Front end detection, Zphase reference)	-34	Count type (front end detection, Z-phase reference)	-36	Stopper type (stopper position reference)	-38	Dog type (rear end detection, rear end reference)	-39	Count type (front end detection, front end reference)	-40	Dog cradle type	-41	Dog type last Z-phase reference	-42	Dog type front end reference	-43	Dogless Z-phase reference																								
	Setting value	Home position return direction	How to execute home position return																																																																					
-1	Address increasing direction	Dog type (Rear end detection Zphase reference)/torque limit changing dog type (Front end detection, Zphase reference)																																																																						
-2		Count type (front end detection, Z-phase reference)																																																																						
-3		Data set type/torque limit changing data set type																																																																						
-4		Stopper type (stopper position reference)																																																																						
-6		Dog type (rear end detection, rear end reference)																																																																						
-7		Count type (front end detection, front end reference)																																																																						
-8		Dog cradle type																																																																						
-9		Dog type last Z-phase reference																																																																						
-10		Dog type front end reference																																																																						
-11		Dogless Z-phase reference																																																																						
Setting value		Home position return direction	How to execute home position return																																																																					
-33	Address decreasing direction	Dog type (Rear end detection Zphase reference)/torque limit changing dog type (Front end detection, Zphase reference)																																																																						
-34		Count type (front end detection, Z-phase reference)																																																																						
-36		Stopper type (stopper position reference)																																																																						
-38		Dog type (rear end detection, rear end reference)																																																																						
-39		Count type (front end detection, front end reference)																																																																						
-40		Dog cradle type																																																																						
-41		Dog type last Z-phase reference																																																																						
-42		Dog type front end reference																																																																						
-43		Dogless Z-phase reference																																																																						
		<table border="1"> <thead> <tr> <th>Setting value</th> <th>Home position return direction</th> <th>How to execute home position return</th> </tr> </thead> <tbody> <tr><td>3</td><td>Address increasing direction</td><td>Method 3</td></tr> <tr><td>4</td><td>Address increasing direction</td><td>Method 4</td></tr> <tr><td>5</td><td>Address decreasing direction</td><td>Method 5</td></tr> <tr><td>6</td><td>Address decreasing direction</td><td>Method 6</td></tr> <tr><td>7</td><td>Address increasing direction</td><td>Method 7</td></tr> <tr><td>8</td><td>Address increasing direction</td><td>Method 8</td></tr> <tr><td>11</td><td>Address decreasing direction</td><td>Method 11</td></tr> <tr><td>12</td><td>Address decreasing direction</td><td>Method 12</td></tr> <tr><td>19</td><td>Address increasing direction</td><td>Method 19</td></tr> <tr><td>20</td><td>Address increasing direction</td><td>Method 20</td></tr> </tbody> </table>	Setting value	Home position return direction	How to execute home position return	3	Address increasing direction	Method 3	4	Address increasing direction	Method 4	5	Address decreasing direction	Method 5	6	Address decreasing direction	Method 6	7	Address increasing direction	Method 7	8	Address increasing direction	Method 8	11	Address decreasing direction	Method 11	12	Address decreasing direction	Method 12	19	Address increasing direction	Method 19	20	Address increasing direction	Method 20	<table border="1"> <thead> <tr> <th>Setting value</th> <th>Home position return direction</th> <th>How to execute home position return</th> </tr> </thead> <tbody> <tr><td>21</td><td>Address decreasing direction</td><td>Method 21</td></tr> <tr><td>22</td><td>Address decreasing direction</td><td>Method 22</td></tr> <tr><td>23</td><td>Address increasing direction</td><td>Method 23</td></tr> <tr><td>24</td><td>Address increasing direction</td><td>Method 24</td></tr> <tr><td>27</td><td>Address decreasing direction</td><td>Method 27</td></tr> <tr><td>28</td><td>Address decreasing direction</td><td>Method 28</td></tr> <tr><td>33</td><td>Address decreasing direction</td><td>Method 33</td></tr> <tr><td>34</td><td>Address increasing direction</td><td>Method 34</td></tr> <tr><td>35</td><td></td><td>Method 35</td></tr> <tr><td>37</td><td></td><td>Method 37 (Data set type)</td></tr> </tbody> </table>	Setting value	Home position return direction	How to execute home position return	21	Address decreasing direction	Method 21	22	Address decreasing direction	Method 22	23	Address increasing direction	Method 23	24	Address increasing direction	Method 24	27	Address decreasing direction	Method 27	28	Address decreasing direction	Method 28	33	Address decreasing direction	Method 33	34	Address increasing direction	Method 34	35		Method 35	37		Method 37 (Data set type)			
Setting value		Home position return direction	How to execute home position return																																																																					
3	Address increasing direction	Method 3																																																																						
4	Address increasing direction	Method 4																																																																						
5	Address decreasing direction	Method 5																																																																						
6	Address decreasing direction	Method 6																																																																						
7	Address increasing direction	Method 7																																																																						
8	Address increasing direction	Method 8																																																																						
11	Address decreasing direction	Method 11																																																																						
12	Address decreasing direction	Method 12																																																																						
19	Address increasing direction	Method 19																																																																						
20	Address increasing direction	Method 20																																																																						
Setting value	Home position return direction	How to execute home position return																																																																						
21	Address decreasing direction	Method 21																																																																						
22	Address decreasing direction	Method 22																																																																						
23	Address increasing direction	Method 23																																																																						
24	Address increasing direction	Method 24																																																																						
27	Address decreasing direction	Method 27																																																																						
28	Address decreasing direction	Method 28																																																																						
33	Address decreasing direction	Method 33																																																																						
34	Address increasing direction	Method 34																																																																						
35		Method 35																																																																						
37		Method 37 (Data set type)																																																																						
PT46 ESTC Synchronous encoder filter time constant		<p>Set a primary delay filter time constant to the synchronous encoder command. Setting this parameter reduces vibration. However, a delay in response to the synchronous encoder will be generated.</p> <p>A setting value when Synchronous control command (C_STS) is turned on will be applied to this parameter.</p> <p>Setting range: 0 to 5000</p>	0 [ms]																																																																					

5. PARAMETERS

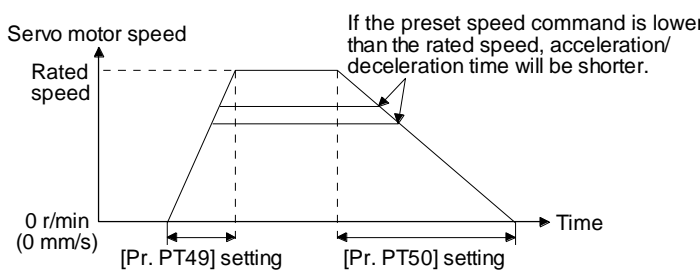
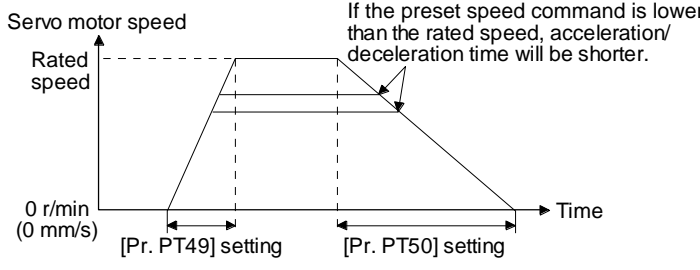
No./ symbol/name	Setting digit	Function	Initial value [unit]	Network		
				ECT	EIP	PNT
PT49 STA Acceleration time constant		<p>Set an acceleration time taken from 0 r/min or 0 mm/s to the rated speed for the command. When a value exceeding 2000 ms is set in other than the profile velocity mode (pv), [AL. F4] will occur and the servo motor cannot be driven.</p> <ul style="list-style-type: none"> • Profile mode Set the acceleration time constant in the position mode and the velocity mode. • Point table method Set the acceleration time constant in the Jog mode (jg). • Indexer method Set the acceleration time constant in the indexer mode (idx) and Jog mode (jg).  <p>For example, for the servo motor with the rated speed of 3000 r/min, set 3000 (3 s) to increase speed from 0 r/min to 1000 r/min in 1 s.</p> <p>This parameter corresponds to "Profile acceleration (Index: 6083h)". When this parameter is mapped for the PDO communication, the value written with Setup software (MR Configurator2™) is overwritten with the upper side. Thus, do not write a value with Setup software (MR Configurator2™).</p> <p>Setting range: 0 to 50000</p>	0 [ms]	<input type="radio"/>		
		<p>Set an acceleration time taken from 0 r/min or 0 mm/s to the rated speed for the command. When a value exceeding 2000 ms is set in other than the profile velocity mode (pv), [AL. F4] will occur and the servo motor cannot be driven.</p> <ul style="list-style-type: none"> • Profile mode Set the acceleration time constant in the position mode and the velocity mode.  <p>For example, for the servo motor with the rated speed of 3000 r/min, set 3000 (3 s) to increase speed from 0 r/min to 1000 r/min in 1 s.</p> <p>This parameter corresponds to "Profile acceleration (Class ID: 64h, Ins ID: 6083h, Attr ID: 0)". When this parameter is mapped for the I/O communication, the value written with Setup software (MR Configurator2™) is overwritten with the upper side. Thus, do not write a value with Setup software (MR Configurator2™).</p> <p>Setting range: 0 to 50000</p>	0 [ms]		<input type="radio"/>	

5. PARAMETERS

No./ symbol/name	Setting digit	Function	Initial value [unit]	Network		
				ECT	EIP	PNT
PT49 STA Acceleration time constant		<p>Set an acceleration time taken from 0 r/min or 0 mm/s to the rated speed for the command. When a value exceeding 2000 ms is set in other than the profile velocity mode (pv), [AL. F4] will occur and the servo motor cannot be driven.</p> <ul style="list-style-type: none"> • Profile mode Set the acceleration time constant in the position mode and the velocity mode. • Point table method Set the acceleration time constant in the Jog mode (jg). • Indexer method Set the acceleration time constant in the indexer mode (idx) and Jog mode (jg). <div style="text-align: center;"> </div> <p>For example, for the servo motor with the rated speed of 3000 r/min, set 3000 (3 s) to increase speed from 0 r/min to 1000 r/min in 1 s.</p> <p>This parameter corresponds to "Profile acceleration (PNU: 24707, Sub: 0)". When this parameter is mapped for the Process Data communication, the value written with Setup software (MR Configurator2™) is overwritten with the upper side. Thus, do not write a value with Setup software (MR Configurator2™).</p> <p>Setting range: 0 to 50000</p>	0 [ms]			○

5. PARAMETERS

No./ symbol/name	Setting digit	Function	Initial value [unit]	Network		
				ECT	EIP	PNT
PT50 STB Deceleration time constant		<p>Set the deceleration time taken from the rated speed to 0 r/min or 0 mm/s to the command. When a value exceeding 2000 ms is set in other than the profile velocity mode (pv), [AL. F4] will occur and the servo motor cannot be driven.</p> <ul style="list-style-type: none"> • Profile mode Set the deceleration time constant in the position mode and the velocity mode. • Point table method Set the deceleration time constant in the Jog mode (jg). • Indexer method Set the deceleration time constant in the indexer mode (idx) and Jog mode (jg). <p>This parameter corresponds to "Profile deceleration (Index: 6084h)". When this parameter is mapped for the PDO communication, the value written with Setup software (MR Configurator2™) is overwritten with the upper side. Thus, do not write a value with Setup software (MR Configurator2™).</p> <p>Setting range: 0 to 50000</p>	0 [ms]	<input type="radio"/>		
		<p>Set the deceleration time taken from the rated speed to 0 r/min or 0 mm/s to the command. When a value exceeding 2000 ms is set in other than the profile velocity mode (pv), [AL. F4] will occur and the servo motor cannot be driven.</p> <ul style="list-style-type: none"> • Profile mode Set the deceleration time constant in the position mode and the velocity mode. <p>This parameter corresponds to "Profile deceleration (Class ID: 64h, Ins ID: 6084h, Attr ID: 0)". When this parameter is mapped for the I/O communication, the value written with Setup software (MR Configurator2™) is overwritten with the upper side. Thus, do not write a value with Setup software (MR Configurator2™).</p> <p>Setting range: 0 to 50000</p>	0 [ms]		<input type="radio"/>	
		<p>Set the deceleration time taken from the rated speed to 0 r/min or 0 mm/s to the command. When a value exceeding 2000 ms is set in other than the profile velocity mode (pv), [AL. F4] will occur and the servo motor cannot be driven.</p> <ul style="list-style-type: none"> • Profile mode Set the deceleration time constant in the position mode and the velocity mode. • Point table method Set the deceleration time constant in the Jog mode (jg). • Indexer method Set the deceleration time constant in the indexer mode (idx) and Jog mode (jg). <p>This parameter corresponds to "Profile deceleration (PNU: 24708, Sub: 0)". When this parameter is mapped for the Process Data communication, the value written with Setup software (MR Configurator2™) is overwritten with the upper side. Thus, do not write a value with Setup software (MR Configurator2™).</p> <p>Setting range: 0 to 50000</p>	0 [ms]			<input type="radio"/>

5. PARAMETERS

No./ symbol/name	Setting digit	Function	Initial value [unit]	Network		
				ECT	EIP	PNT
PT51 STC S-pattern acceleration/ deceleration time constant		<p>This parameter is used to smooth the start/stop of the servo motor or linear servo motor.</p> <p>Set the time of the arc part for S-pattern acceleration/deceleration. Setting "0" will make it linear acceleration/deceleration.</p> <p>Long setting of STA (acceleration time constant) or STB (deceleration time constant) may produce deviation in the set time of the arc part for the S-pattern acceleration/deceleration time constant. The setting will be disabled at home position return. To enable the parameter values, cycle the power after setting.</p> <ul style="list-style-type: none"> - Profile mode When a value exceeding 1000 ms is set in other than the profile velocity mode (pv), the parameter value will be clamped to 1000 ms. Specify STA (acceleration time constant) and STB (deceleration time constant) with "Profile acceleration (Index: 6083h)" and "Profile deceleration (Index: 6084h)". This function will be enabled in the profile position mode (pp) and profile velocity mode (pv). - Point table method When a value exceeding 1000 ms is set, the parameter value will be clamped to 1000 ms. Specify STA (acceleration time constant) and STB (deceleration time constant) with the point table. <p>The upper limit value of the actual arc part time is limited by</p> $\frac{2000000}{STA} \text{ for acceleration or by } \frac{2000000}{STB} \text{ for deceleration.}$ <p>(Example) When STA = 20000, STB = 5000 and STC = 200, the actual arc part times are as follows.</p> <p>At acceleration: 100 ms $\frac{2000000}{20000} = 100 \text{ [ms]} < 200 \text{ [ms]}$ Therefore, it will be limited to 100 [ms].</p> <p>At deceleration: 200 ms $\frac{2000000}{5000} = 400 \text{ [ms]} > 200 \text{ [ms]}$ Therefore, it will be 200 [ms] as you set.</p> <p>Setting range: 0 to 5000</p>	0 [ms]	○		

5. PARAMETERS

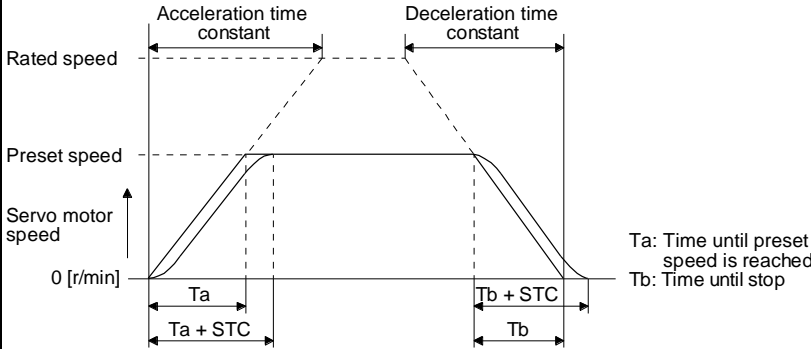
No./ symbol/name	Setting digit	Function	Initial value [unit]	Network		
				ECT	EIP	PNT
PT51 STC S-pattern acceleration/ deceleration time constant		<p>This parameter is used to smooth the start/stop of the servo motor or linear servo motor.</p> <p>Set the time of the arc part for S-pattern acceleration/deceleration. Setting "0" will make it linear acceleration/deceleration.</p>  <p>Long setting of STA (acceleration time constant) or STB (deceleration time constant) may produce deviation in the set time of the arc part for the S-pattern acceleration/deceleration time constant. The setting will be disabled at home position return. To enable the parameter values, cycle the power after setting.</p> <ul style="list-style-type: none"> - Profile mode <p>When a value exceeding 1000 ms is set in other than the profile velocity mode (pv), the parameter value will be clamped to 1000 ms.</p> <p>Specify STA (acceleration time constant) and STB (deceleration time constant) with "Profile acceleration (Class ID: 64h, Ins ID: 6083h, Attr ID: 0)" and "Profile deceleration (Class ID: 64h, Ins ID: 6084h, Attr ID: 0)".</p> <p>This function will be enabled in the profile position mode (pp) and profile velocity mode (pv).</p> <p>The upper limit value of the actual arc part time is limited by</p> $\frac{2000000}{STA} \text{ for acceleration or by } \frac{2000000}{STB} \text{ for deceleration.}$ <p>(Example) When STA = 20000, STB = 5000 and STC = 200, the actual arc part times are as follows.</p> <p>At acceleration: 100 ms $\frac{2000000}{20000} = 100 \text{ [ms]} < 200 \text{ [ms]}$ Therefore, it will be limited to 100 [ms].</p> <p>At deceleration: 200 ms $\frac{2000000}{5000} = 400 \text{ [ms]} > 200 \text{ [ms]}$ Therefore, it will be 200 [ms] as you set.</p> <p>Setting range: 0 to 5000</p>	0 [ms]		<input type="radio"/>	

5. PARAMETERS

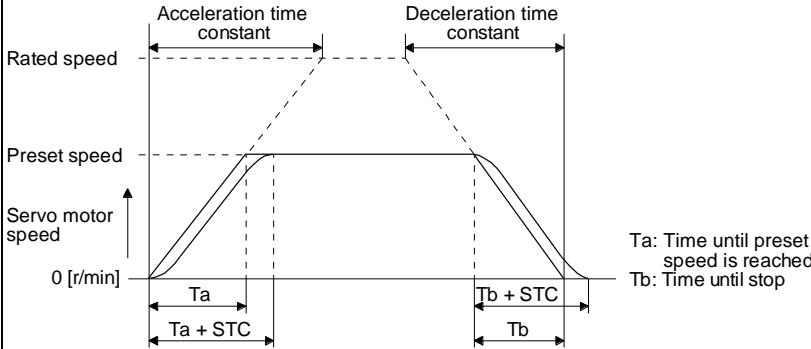
No./ symbol/name	Setting digit	Function	Initial value [unit]	Network		
				ECT	EIP	PNT
PT51 STC S-pattern acceleration/ deceleration time constant		<p>This parameter is used to smooth the start/stop of the servo motor or linear servo motor.</p> <p>Set the time of the arc part for S-pattern acceleration/deceleration. Setting "0" will make it linear acceleration/deceleration.</p>  <p>Long setting of STA (acceleration time constant) or STB (deceleration time constant) may produce deviation in the set time of the arc part for the S-pattern acceleration/deceleration time constant. The setting will be disabled at home position return. To enable the parameter values, cycle the power after setting.</p> <ul style="list-style-type: none"> • Profile mode When a value exceeding 1000 ms is set in other than the profile velocity mode (pv), the parameter value will be clamped to 1000 ms. Specify STA (acceleration time constant) and STB (deceleration time constant) with "Profile acceleration (PNU: 24707, Sub: 0)" and "Profile deceleration (PNU: 24708, Sub: 0)". This function will be enabled in the profile position mode (pp) and profile velocity mode (pv). • Point table method When a value exceeding 1000 ms is set, the parameter value will be clamped to 1000 ms. Specify STA (acceleration time constant) and STB (deceleration time constant) with the point table. <p>The upper limit value of the actual arc part time is limited by</p> $\frac{2000000}{STA} \text{ for acceleration or by } \frac{2000000}{STB} \text{ for deceleration.}$ <p>(Example) When STA = 20000, STB = 5000 and STC = 200, the actual arc part times are as follows.</p> <p>At acceleration: 100 ms $\frac{2000000}{20000} = 100 \text{ [ms]} < 200 \text{ [ms]}$ Therefore, it will be limited to 100 [ms].</p> <p>At deceleration: 200 ms $\frac{2000000}{5000} = 400 \text{ [ms]} > 200 \text{ [ms]}$ Therefore, it will be 200 [ms] as you set.</p> <p>Setting range: 0 to 5000</p>	0 [ms]			○

5. PARAMETERS

No./ symbol/name	Setting digit	Function	Initial value [unit]	Network		
				ECT	EIP	PNT
PT53 TQS Torque slope		<p>Set the rate of change of the torque command per second. However, setting "0.0" will disable the torque slope. This function will be enabled in the profile torque mode (tq).</p> <p>This parameter corresponds to "Torque slope (Index: 6087h)". When this parameter is mapped for the PDO communication, the value written with Setup software (MR Configurator2™) is overwritten with the upper side. Thus, do not write a value with Setup software (MR Configurator2™).</p> <p>Setting range: 0.0 to 1000000.0</p>	0.0 [%/s]	<input type="radio"/>		
		<p>Set the rate of change of the torque command per second. However, setting "0.0" will disable the torque slope. This function will be enabled in the profile torque mode (tq).</p> <p>This parameter corresponds to "Torque slope (Class ID: 64h, Ins ID: 6087h, Attr ID: 0)". When this parameter is mapped for the I/O communication, the value written with Setup software (MR Configurator2™) is overwritten with the upper side. Thus, do not write a value with Setup software (MR Configurator2™).</p> <p>Setting range: 0.0 to 1000000.0</p>	0.0 [%/s]		<input type="radio"/>	
		<p>Set the rate of change of the torque command per second. However, setting "0.0" will disable the torque slope. This function will be enabled in the profile torque mode (tq).</p> <p>This parameter corresponds to "Torque slope (PNU: 24711, Sub: 0)". When this parameter is mapped for the Process Data communication, the value written with Setup software (MR Configurator2™) is overwritten with the upper side. Thus, do not write a value with Setup software (MR Configurator2™).</p> <p>Setting range: 0.0 to 1000000.0</p>	0.0 [%/s]			<input type="radio"/>
PT55 *TOP8 Function selection T-8	___x	<p>Home position return - Deceleration time constant selection</p> <p>Set a value used for the acceleration time constant and deceleration time constant at home position return.</p> <p>0: Using [Pr. PT56] for both acceleration time constant and deceleration time constant 1: Using [Pr. PT56] for acceleration time constant, and [Pr. PT57] for deceleration time constant</p>	0h	<input type="radio"/>	<input type="radio"/>	<input type="radio"/>
	__x_	For manufacturer setting	0h	<input type="checkbox"/>	<input type="checkbox"/>	<input type="checkbox"/>
	_x__		0h	<input type="checkbox"/>	<input type="checkbox"/>	<input type="checkbox"/>
	x___		0h	<input type="checkbox"/>	<input type="checkbox"/>	<input type="checkbox"/>

5. PARAMETERS

No./ symbol/name	Setting digit	Function	Initial value [unit]	Network		
				ECT	EIP	PNT
PT56 HMA Home position return acceleration time constant		<p>Set the acceleration time constant for the home position return. Set the acceleration time taken from 0 r/min or 0 mm/s to the rated speed.</p> <p>When "Use [Pr. PT56] as both acceleration time constant and deceleration time constant (0 _ _ _)" is selected in [Pr. PT55] Home position return - Deceleration time constant selection, the value set in this parameter is used as a deceleration time constant at home position return.</p> <p>This parameter corresponds to "Homing acceleration (Index: 609Ah)". When this parameter is mapped for the PDO communication, the value written with Setup software (MR Configurator2™) is overwritten with the upper side. Thus, do not write a value with Setup software (MR Configurator2™).</p> <p>Setting range: 0 to 20000</p>	0 [ms]	<input type="radio"/>		
		<p>Set the acceleration time constant for the home position return. Set the acceleration time taken from 0 r/min or 0 mm/s to the rated speed.</p> <p>When "Use [Pr. PT56] as both acceleration time constant and deceleration time constant (0 _ _ _)" is selected in [Pr. PT55] Home position return - Deceleration time constant selection, the value set in this parameter is used as a deceleration time constant at home position return.</p> <p>This parameter corresponds to "Homing acceleration (Class ID: 64h, Ins ID: 609Ah, Attr ID: 0)". When this parameter is mapped for the I/O communication, the value written with Setup software (MR Configurator2™) is overwritten with the upper side. Thus, do not write a value with Setup software (MR Configurator2™).</p> <p>Setting range: 0 to 20000</p>	0 [ms]		<input type="radio"/>	
		<p>Set the acceleration time constant for the home position return. Set the acceleration time taken from 0 r/min or 0 mm/s to the rated speed.</p> <p>When "Use [Pr. PT56] as both acceleration time constant and deceleration time constant (0 _ _ _)" is selected in [Pr. PT55] Home position return - Deceleration time constant selection, the value set in this parameter is used as a deceleration time constant at home position return.</p> <p>This parameter corresponds to "Homing acceleration (PNU: 24730, Sub: 0)". When this parameter is mapped for the Process Data communication, the value written with Setup software (MR Configurator2™) is overwritten with the upper side. Thus, do not write a value with Setup software (MR Configurator2™).</p> <p>Setting range: 0 to 20000</p>	0 [ms]			<input type="radio"/>
PT57 HMB Home position return deceleration time constant		<p>Set the deceleration time constant at the home position return. Set a deceleration time from the rated speed to 0 r/min or 0 mm/s.</p> <p>The parameter will be enabled when you select "Using [Pr. PT56] for acceleration time constant, and [Pr. PT57] for deceleration time constant (1 _ _ _)" of "Home position return - Deceleration time constant selection" in [Pr. PT55].</p> <p>Setting range: 0 to 20000</p>	0 [ms]	<input type="radio"/>	<input type="radio"/>	<input type="radio"/>
PT65 PVC Profile speed command		<p>Set the speed of the profile speed command. The fractional portion of the parameter will be rounded down. The setting value will be clamped at the instantaneous permissible speed.</p> <p>This function will be enabled in the profile position mode (pp), Jog mode (jg) and indexer mode (idx).</p> <p>This parameter corresponds to "Profile velocity (Index: 6081h)". When this parameter is mapped for the PDO communication, the value written with Setup software (MR Configurator2™) is overwritten with the upper side. Thus, do not write a value with Setup software (MR Configurator2™).</p> <p>Setting range: 0.00 to 167772.15</p>	100.00 [r/min]/ [mm/s]	<input type="radio"/>		

5. PARAMETERS

No./ symbol/name	Setting digit	Function	Initial value [unit]	Network		
				ECT	EIP	PNT
PT65 PVC Profile speed command		<p>Set the speed of the profile speed command. The fractional portion of the parameter will be rounded down. The setting value will be clamped at the instantaneous permissible speed.</p> <p>This function will be enabled in the profile position mode (pp).</p> <p>This parameter corresponds to "Profile velocity (Class ID: 64h, Ins ID: 6081h, Attr ID: 0)". When this parameter is mapped for the I/O communication, the value written with Setup software (MR Configurator2™) is overwritten with the upper side. Thus, do not write a value with Setup software (MR Configurator2™).</p> <p>Setting range: 0.00 to 167772.15</p>	100.00 [r/min]/ [mm/s]		<input type="radio"/>	
		<p>Set the speed of the profile speed command. The fractional portion of the parameter will be rounded down. The setting value will be clamped at the instantaneous permissible speed.</p> <p>This function will be enabled in the profile position mode (pp), Jog mode (jg) and indexer mode (idx).</p> <p>This parameter corresponds to "Profile velocity (PNU: 24705, Sub: 0)". When this parameter is mapped for the Process Data communication, the value written with Setup software (MR Configurator2™) is overwritten with the upper side. Thus, do not write a value with Setup software (MR Configurator2™).</p> <p>Setting range: 0.00 to 167772.15</p>	100.00 [r/min]/ [mm/s]			<input type="radio"/>
PT66 MPVC Maximum profile speed		<p>Set the maximum profile speed.</p> <p>This function will be enabled in the profile position mode (pp), profile velocity mode (pv), Jog mode (jg) and indexer mode (idx).</p> <p>The fractional portion of this parameter will be rounded down in the profile position mode (pp), Jog mode (jg) and indexer mode (idx).</p> <p>This parameter corresponds to "Max profile velocity (Index: 607Fh)". When this parameter is mapped for the PDO communication, the value written with Setup software (MR Configurator2™) is overwritten with the upper side. Thus, do not write a value with Setup software (MR Configurator2™).</p> <p>Setting range: 0.00 to 20000.00</p>	20000.00 [r/min]/ [mm/s]	<input type="radio"/>		
		<p>Set the maximum profile speed.</p> <p>This function will be enabled in the profile position mode (pp) and profile velocity mode (pv).</p> <p>The fractional portion of this parameter will be rounded down in the profile position mode (pp).</p> <p>This parameter corresponds to "Max profile velocity (Class ID: 64h, Ins ID: 607Fh, Attr ID: 0)". When this parameter is mapped for the I/O communication, the value written with Setup software (MR Configurator2™) is overwritten with the upper side. Thus, do not write a value with Setup software (MR Configurator2™).</p> <p>Setting range: 0.00 to 20000.00</p>	20000.00 [r/min]/ [mm/s]		<input type="radio"/>	
		<p>Set the maximum profile speed.</p> <p>This function will be enabled in the profile position mode (pp), profile velocity mode (pv), Jog mode (jg) and indexer mode (idx).</p> <p>The fractional portion of this parameter will be rounded down in the profile position mode (pp), Jog mode (jg) and indexer mode (idx).</p> <p>This parameter corresponds to "Max profile velocity (PNU: 24703, Sub: 0)". When this parameter is mapped for the Process Data communication, the value written with Setup software (MR Configurator2™) is overwritten with the upper side. Thus, do not write a value with Setup software (MR Configurator2™).</p> <p>Setting range: 0.00 to 20000.00</p>	20000.00 [r/min]/ [mm/s]			<input type="radio"/>

5. PARAMETERS

No./ symbol/name	Setting digit	Function	Initial value [unit]	Network		
				ECT	EIP	PNT
PT67 VLMT Speed limit		<p>Set the maximum speed in the torque control. The setting value will be clamped at the instantaneous permissible speed. This function will be enabled in the profile torque mode (tq) and cyclic synchronous torque mode (cst).</p> <p>This parameter corresponds to "Velocity limit value (Index: 2D20h)". When this parameter is mapped for the PDO communication, the value written with Setup software (MR Configurator2™) is overwritten with the upper side. Thus, do not write a value with Setup software (MR Configurator2™).</p> <p>Setting range: 0.00 to 167772.15</p>	500.00 [r/min]/ [mm/s]	<input type="radio"/>		
		<p>Set the maximum speed in the torque control. The setting value will be clamped at the instantaneous permissible speed. This function will be enabled in the profile torque mode (tq).</p> <p>This parameter corresponds to "Velocity limit value (Class ID: 64h, Ins ID: 2D20h, Attr ID: 0)". When this parameter is mapped for the I/O communication, the value written with Setup software (MR Configurator2™) is overwritten with the upper side. Thus, do not write a value with Setup software (MR Configurator2™).</p> <p>Setting range: 0.00 to 167772.15</p>	500.00 [r/min]/ [mm/s]		<input type="radio"/>	
		<p>Set the maximum speed in the torque control. The setting value will be clamped at the instantaneous permissible speed. This function will be enabled in the profile torque mode (tq).</p> <p>This parameter corresponds to "Velocity limit value (PNU: 11522, Sub: 0)". When this parameter is mapped for the Process Data communication, the value written with Setup software (MR Configurator2™) is overwritten with the upper side. Thus, do not write a value with Setup software (MR Configurator2™).</p> <p>Setting range: 0.00 to 167772.15</p>	500.00 [r/min]/ [mm/s]			<input type="radio"/>
PT69 ZSTH Home position shift distance (extension parameter)		<p>This parameter is the extension parameter of [Pr. PT07]. When [Pr. PT69] is used, the home position shift distance is calculated as follows. Home position shift distance = [Pr. PT07] + ([Pr. PT69] × 65536) The unit of this parameter will be as follows depending on the setting of [Pr. PA01].</p> <ul style="list-style-type: none"> In the cyclic synchronous mode The unit is [pulse]. Profile mode and point table method The unit can be changed to [μm], 10⁻⁴ [inch], 10⁻³ [degree] or [pulse] with the setting of [Pr. PT01]. Indexer method It will be command unit [pulse]. (A load-side rotation expressed by the number of servo motor resolution pulses) Refer to the Function column of [Pr. PA10] for the command unit [pulse]. Additionally, when a value equal to or more than "1001" is set, the value will be clamped to "1000". <p>Setting range: 0 to 32767</p>	0 Refer to Function column for unit.	<input type="radio"/>	<input type="radio"/>	<input type="radio"/>

5. PARAMETERS

No./ symbol/name	Setting digit	Function	Initial value [unit]	Network		
				ECT	EIP	PNT
PT71 DCTH Travel distance after proximity dog (extension parameter)		<p>This parameter is the extension parameter of [Pr. PT09]. When [Pr. PT71] is used, the travel distance after proximity dog is calculated as follows. Travel distance after proximity dog = [Pr. PT09] + ([Pr. PT71] × 65536) This function will be enabled in the profile mode and cyclic synchronous mode. The unit can be changed to 10^{STM} [μm], 10^(STM-4) [inch], 10⁻³ [degree] or [pulse] according to the setting of [Pr. PT01].</p> <p>Setting range: 0 to 32767</p>	0 Refer to Function column for unit.	<input type="radio"/>	<input type="radio"/>	<input type="radio"/>
PT72 ECMXL Synchronous encoder electronic gear - Numerator (lower four digits)		<p>Set an electronic gear numerator for converting a synchronous encoder command into a command unit. Upper and lower are a set. Set the electronic gear in hexadecimal.</p> <p>Setting value of this parameter:</p> <div style="text-align: center;"> </div> <p>Set a value within the following range. When a value outside the range is set, synchronous control error will occur and synchronous control will not start even though Synchronous control command (Control DI7 bit 12) is input. Setting "0" will apply "1".</p> $\frac{1}{16000} < \frac{\text{Synchronous encoder electronic gear - Numerator}}{\text{Synchronous encoder electronic gear - Denominator}} < 6000$ <p>To enable the parameter value, cycle the power or turn on Analysis command (Control DI 7 bit 14).</p> <p>This parameter corresponds to "External encoder gear numerator (Class ID: 64h, Ins ID: 2DF0h, Attr ID: 1)". When this parameter is mapped for the I/O communication, the value written with Setup software (MR Configurator2™) is overwritten with the upper side. Thus, do not write a value with Setup software (MR Configurator2™).</p> <p>Setting range: 00000000h to FFFFFFFFh</p>	0000h	<input type="radio"/>		
PT73 ECMXH Synchronous encoder electronic gear - Numerator (upper four digits)		<p>Set an electronic gear numerator for converting a synchronous encoder command into a command unit. Upper and lower are a set. Refer to [Pr. PT72] for details.</p>	0000h	<input type="radio"/>		

5. PARAMETERS

No./ symbol/name	Setting digit	Function	Initial value [unit]	Network		
				ECT	EIP	PNT
PT74 ECDVL Synchronous encoder electronic gear - Denominator (lower four digits)		<p>Set an electronic gear denominator for converting a synchronous encoder command into a command unit. Upper and lower are a set. Set the electronic gear in hexadecimal.</p> <p>Setting value of this parameter:</p> <div style="text-align: center;"> <pre> {-----} {-----} Upper four Lower four digits digits +-----+ +-----+ [Pr. PT74] +-----+ [Pr. PT75] </pre> </div> <p>Set a value within the following range. When a value outside the range is set, synchronous control error will occur and synchronous control will not start even though Synchronous control command (Control DI7 bit 12) is input. Setting "0" will apply "1".</p> $\frac{1}{16000} < \frac{\text{Synchronous encoder electronic gear - Numerator}}{\text{Synchronous encoder electronic gear - Denominator}} < 6000$ <p>To enable the parameter value, cycle the power or turn on Analysis command (Control DI 7 bit 14).</p> <p>This parameter corresponds to "External encoder gear denominator (Class ID: 64h, Ins ID: 2DF0h, Attr ID: 2)". When this parameter is mapped for the I/O communication, the value written with Setup software (MR Configurator2™) is overwritten with the upper side. Thus, do not write a value with Setup software (MR Configurator2™).</p> <p>Setting range: 00000000h to FFFFFFFFh</p>	0000h		○	
PT75 ECDVH Synchronous encoder electronic gear - Denominator (upper four digits)		<p>Set an electronic gear denominator for converting a synchronous encoder command into a command unit. Upper and lower are a set. Refer to [Pr. PT74] for details.</p>	0000h		○	

5. PARAMETERS

5.2.8 Network setting parameters ([Pr. PN_ _])

No./ symbol/name	Setting digit	Function	Initial value [unit]	Network														
				ECT	EIP	PNT												
PN01 **NADR Node address setting		Set the node address of the network. When using the parameter, set the axis selection rotary switch to "00h". The parameter will be enabled for the EtherCAT. Setting range: 0000h to FFFFh	0000h	<input type="radio"/>														
PN02 CERT Sync Error Counter Limit setting		Set the time until [AL. 86.1 Network communication error 1] is detected. <table border="1" style="width: 100%; border-collapse: collapse;"> <thead> <tr> <th>[Pr. PN06]</th> <th>[Pr. PN02]</th> <th>Sync Error Counter Limit (Index: 10F1h: 2)</th> </tr> </thead> <tbody> <tr> <td rowspan="2">Automatic setting (0 _ _ _)</td> <td>0</td> <td>The threshold at which [AL. 86.1] is detected is automatically set at 7 ms.</td> </tr> <tr> <td>Other than 0 (Note 3)</td> <td>The threshold at which [AL. 86.1] is detected is automatically set at ([Pr. PN02]/96) ms.</td> </tr> <tr> <td rowspan="2">Manual setting (1 _ _ _) (Note 1)</td> <td>0 (Note 2)</td> <td>Disabled (0) [AL. 86.1] is not detected.</td> </tr> <tr> <td>Other than 0 (Note 3)</td> <td>The value of [Pr. PN02] is set. [AL. 86.1] is detected at (([Pr. PN02]/3) x communication cycle) ms.</td> </tr> </tbody> </table> <p>2. If the setting value is set to "0", the servo motor cannot be stopped when a communication error occurs.</p> <p>3. If the setting value is increased, it takes longer for the servo motor to stop at the occurrence of a communication error. Be careful when changing the setting value as it may cause a collision.</p> <p>This parameter corresponds to "Sync Error Counter Limit (Index: 10F1h, Sub:2)". Setting range: 0 to 32767</p>	[Pr. PN06]	[Pr. PN02]	Sync Error Counter Limit (Index: 10F1h: 2)	Automatic setting (0 _ _ _)	0	The threshold at which [AL. 86.1] is detected is automatically set at 7 ms.	Other than 0 (Note 3)	The threshold at which [AL. 86.1] is detected is automatically set at ([Pr. PN02]/96) ms.	Manual setting (1 _ _ _) (Note 1)	0 (Note 2)	Disabled (0) [AL. 86.1] is not detected.	Other than 0 (Note 3)	The value of [Pr. PN02] is set. [AL. 86.1] is detected at (([Pr. PN02]/3) x communication cycle) ms.	0 Refer to Function column for unit.	<input type="radio"/>	
[Pr. PN06]	[Pr. PN02]	Sync Error Counter Limit (Index: 10F1h: 2)																
Automatic setting (0 _ _ _)	0	The threshold at which [AL. 86.1] is detected is automatically set at 7 ms.																
	Other than 0 (Note 3)	The threshold at which [AL. 86.1] is detected is automatically set at ([Pr. PN02]/96) ms.																
Manual setting (1 _ _ _) (Note 1)	0 (Note 2)	Disabled (0) [AL. 86.1] is not detected.																
	Other than 0 (Note 3)	The value of [Pr. PN02] is set. [AL. 86.1] is detected at (([Pr. PN02]/3) x communication cycle) ms.																
PN06 *NOP1 Function selection N-1	_ _ _ x _ _ x _ _ x _ _ x _ _ _	For manufacturer setting Sync Error Counter Limit setting 0: Automatic setting 1: Manual setting The threshold at which [AL. 86.1 Network communication error 1] is detected can be set according to the setting value in this digit and the value of [Pr. PN02]. Refer to the function column [Pr. PN02] for details.	0h	<input type="radio"/>														

5.3 Software limit

The limit stop with the software limit ([Pr. PT15] to [Pr. PT18]) is the same as the motion of the stroke end. Exceeding a setting range will stop and servo-lock the shaft. This will be enabled at power-on and will be disabled in the velocity mode, torque mode, and homing mode (hm). Setting a same value to "Software limit +" and "Software limit -" will disable this function. Setting a larger value to "Software limit -" than "Software limit +" will disable this function.

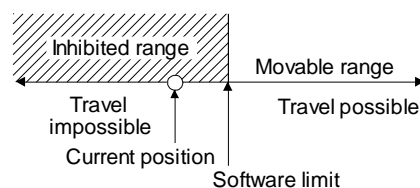

5. PARAMETERS

5.4 How to set the electronic gear

5.4.1 Electronic gear setting in the cyclic synchronous mode, profile mode and point table method

POINT
<ul style="list-style-type: none"> The position data unit that can be set vary depending on the control mode. Refer to [Pr. PT01 Position data unit] for details.

(1) Setting [mm], [inch], or [pulse] with "Position data unit" of [Pr. PT01]

Adjust [Pr. PA06] and [Pr. PA07] to match the driver setting with the travel distance of the machine.

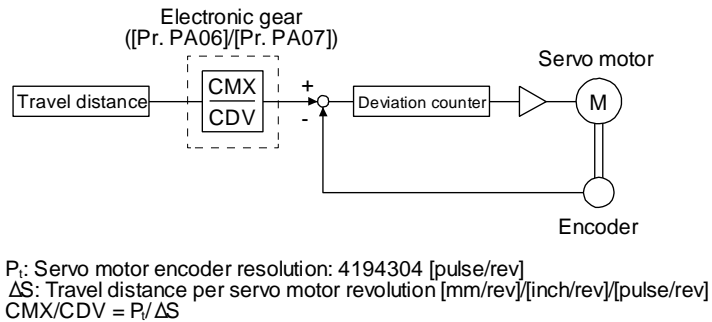

The following setting example explains how to calculate the electronic gear.

POINT
<ul style="list-style-type: none"> To calculate the electronic gear, the following specification symbols are required. <p>Pb: Ball screw lead [mm] 1/n: Reduction ratio P_t: Servo motor encoder resolution [pulse/rev] ΔS: Travel distance per servo motor revolution [mm/rev]</p>

(a) Setting example of a ball screw

Machine specifications

Ball screw lead Pb = 10 [mm]

Reduction ratio: $1/n = Z_1/Z_2 = 1/2$

Z_1 : Number of gear teeth on servo motor side

Z_2 : Number of gear teeth on load gear

Servo motor encoder resolution $P_t = 4194304$ [pulse/rev]

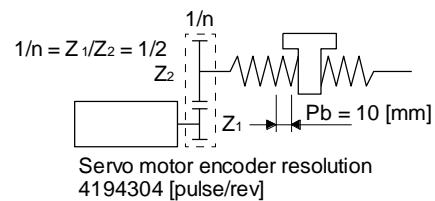

$$\frac{CMX}{CDV} = \frac{P_t}{\Delta S} = \frac{P_t}{1/n \cdot Pb \cdot \alpha(\text{Note})} = \frac{4194304}{1/2 \cdot 10 \cdot 1000} = \frac{4194304}{5000} = \frac{524288}{625}$$

Note. Because the command unit is "mm", α is 1000. When the unit is "inch", α is 10000. When the unit is "pulse", α is 1.

Therefore, set CMX = 524288 and CDV = 625.

5. PARAMETERS

(b) Setting example of a conveyor

Machine specifications

Pulley diameter: $r = 160$ [mm]

Reduction ratio: $1/n = Z_1/Z_2 = 1/3$

Z_1 : Number of gear teeth on servo motor side

Z_2 : Number of gear teeth on load gear

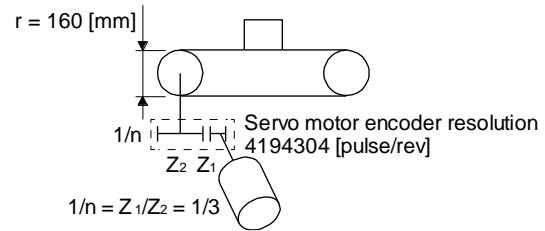

Servo motor encoder resolution $P_t = 4194304$ [pulse/rev]

$$\frac{CMX}{CDV} = \frac{P_t}{\Delta S} = \frac{P_t}{1/n \cdot r \cdot \pi \cdot \alpha(\text{Note})} = \frac{4194304}{1/3 \cdot 160 \cdot \pi \cdot 1000} = \frac{4194304}{167551.61} \approx \frac{524288}{20944}$$

Note. Because the command unit is "mm", α is 1000. When the unit is "inch", α is 10000. When the unit is "pulse", α is 1.

Reduce CMX and CDV to within the setting range or lower and round off each value to the closest whole number.

Therefore, set $CMX = 524288$ and $CDV = 20944$.

(2) Setting [degree] with "Position data unit" of [Pr. PT01].

Set the number of gear teeth on machine side to [Pr. PA06] and the number of gear teeth on servo motor side to [Pr. PA07].

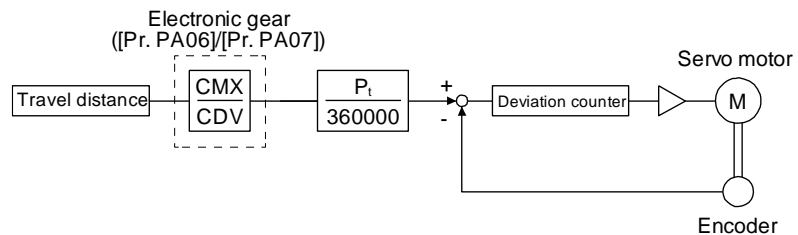

P_t : Servo motor encoder resolution: 4194304 [pulse/rev]

Set the electronic gear within the following range. Setting out of the range will trigger [AL. 37 Parameter error].

- (a) Set values to make numerator and denominator 16384 or lower if the electronic gear (CMX/CDV) is reduced to its lowest terms.
- (b) Set values to make numerator and denominator 16777216 or lower if $(CMX \times P_t)/(CDV \times 360000)$ is reduced to its lowest terms.

The following shows a setting example of the electronic gear.

Number of gear teeth on machine side: 25, number of gear teeth on servo motor side: 11

Set [Pr. PA06] = 25 and [Pr. PA07] = 11.

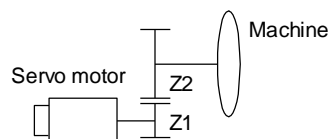

P_t (Servo motor resolution): 4194304 pulses/rev

Z_1 : Number of gear teeth on servo motor side

Z_2 : Number of gear teeth on machine side

$Z_1 : Z_2 = 11 : 25$

5. PARAMETERS

5.4.2 Electronic gear setting in the indexer method

Adjust [Pr. PA06] and [Pr. PA07] to align the rotation amount "m" of the servo motor shaft necessary to rotate the load side for "n" times. The following shows a setting example of the electronic gear.

- (1) Number of pulley teeth on machine side: 50, number of pulley teeth on servo motor side: 20
Set [Pr. PA06] = 50 and [Pr. PA07] = 20.

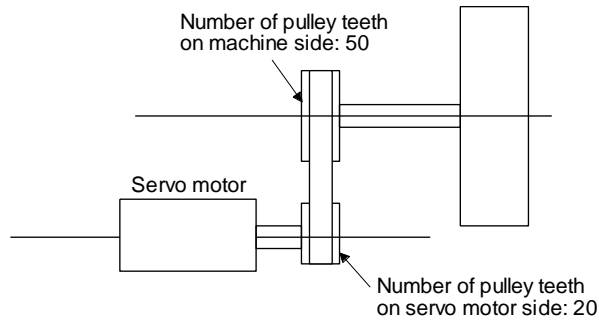

- (2) Number of pulley teeth on machine side: 50, number of pulley teeth on servo motor side: 20, with geared servo motor of 1/9
Set [Pr. PA06] = 450 and [Pr. PA07] = 20.

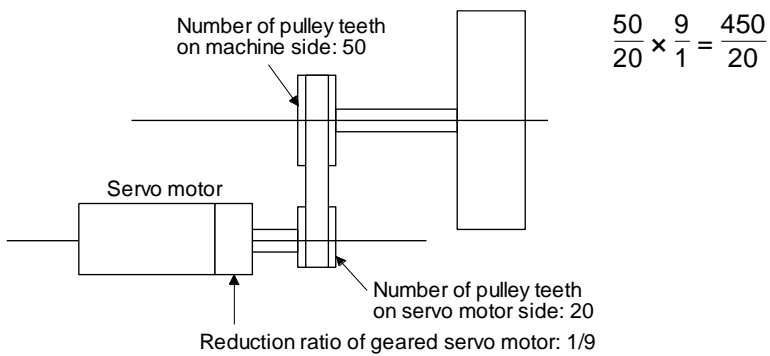

6. NORMAL GAIN ADJUSTMENT

6. NORMAL GAIN ADJUSTMENT	2
6.1 Different adjustment methods.....	2
6.1.1 Adjustment on a single driver.....	2
6.1.2 Adjustment using setup software (MR Configurator2™)	3
6.2 One-touch tuning	4
6.2.1 One-touch tuning flowchart	5
6.2.2 Display transition and operation procedure of one-touch tuning.....	6
6.2.3 Caution for one-touch tuning	11
6.3 Auto tuning	12
6.3.1 Auto tuning mode.....	12
6.3.2 Auto tuning mode basis	13
6.3.3 Adjustment procedure by auto tuning.....	14
6.3.4 Response level setting in auto tuning mode.....	15
6.4 Manual mode	16
6.5 2gain adjustment mode	20

6. NORMAL GAIN ADJUSTMENT

6. NORMAL GAIN ADJUSTMENT

POINT
<ul style="list-style-type: none"> ● In the torque control mode, you do not need to make gain adjustment. ● Before making gain adjustment, check that your machine is not being operated at maximum torque of the servo motor. If operated over maximum torque, the machine may vibrate and may operate unexpectedly. In addition, make gain adjustment with a safety margin considering characteristic differences of each machine. It is recommended that generated torque during operation is under 90% of the maximum torque of the servo motor. ● For the vibration suppression control tuning mode, the setting range of [Pr. PB07] is limited. Refer to section 7.1.5 (4) for details.

6.1 Different adjustment methods

6.1.1 Adjustment on a single driver

The following table shows the gain adjustment modes that can be set on a single driver. For gain adjustment, first execute "Auto tuning mode 1". If you are not satisfied with the result of the adjustment, execute "Auto tuning mode 2" and "Manual mode" in this order.

(1) Gain adjustment mode explanation

Gain adjustment mode	[Pr. PA08] setting	Estimation of load to motor inertia ratio	Automatically set parameters	Manually set parameters
Auto tuning mode 1 (initial value)	--- 1	Always estimated	GD2 ([Pr. PB06]) PG1 ([Pr. PB07]) PG2 ([Pr. PB08]) VG2 ([Pr. PB09]) VIC ([Pr. PB10])	RSP ([Pr. PA09])
Auto tuning mode 2	--- 2	Fixed to [Pr. PB06] value	PG1 ([Pr. PB07]) PG2 ([Pr. PB08]) VG2 ([Pr. PB09]) VIC ([Pr. PB10])	GD2 ([Pr. PB06]) RSP ([Pr. PA09])
Manual mode	--- 3		/	GD2 ([Pr. PB06]) PG1 ([Pr. PB07]) PG2 ([Pr. PB08]) VG2 ([Pr. PB09]) VIC ([Pr. PB10])
2 gain adjustment mode 1 (interpolation mode)	--- 0	Always estimated	GD2 ([Pr. PB06]) PG2 ([Pr. PB08]) VG2 ([Pr. PB09]) VIC ([Pr. PB10])	PG1 ([Pr. PB07]) RSP ([Pr. PA09])
2 gain adjustment mode 2	--- 4	Fixed to [Pr. PB06] value	PG2 ([Pr. PB08]) VG2 ([Pr. PB09]) VIC ([Pr. PB10])	GD2 ([Pr. PB06]) PG1 ([Pr. PB07]) RSP ([Pr. PA09])

6. NORMAL GAIN ADJUSTMENT

(2) Adjustment sequence and mode usage

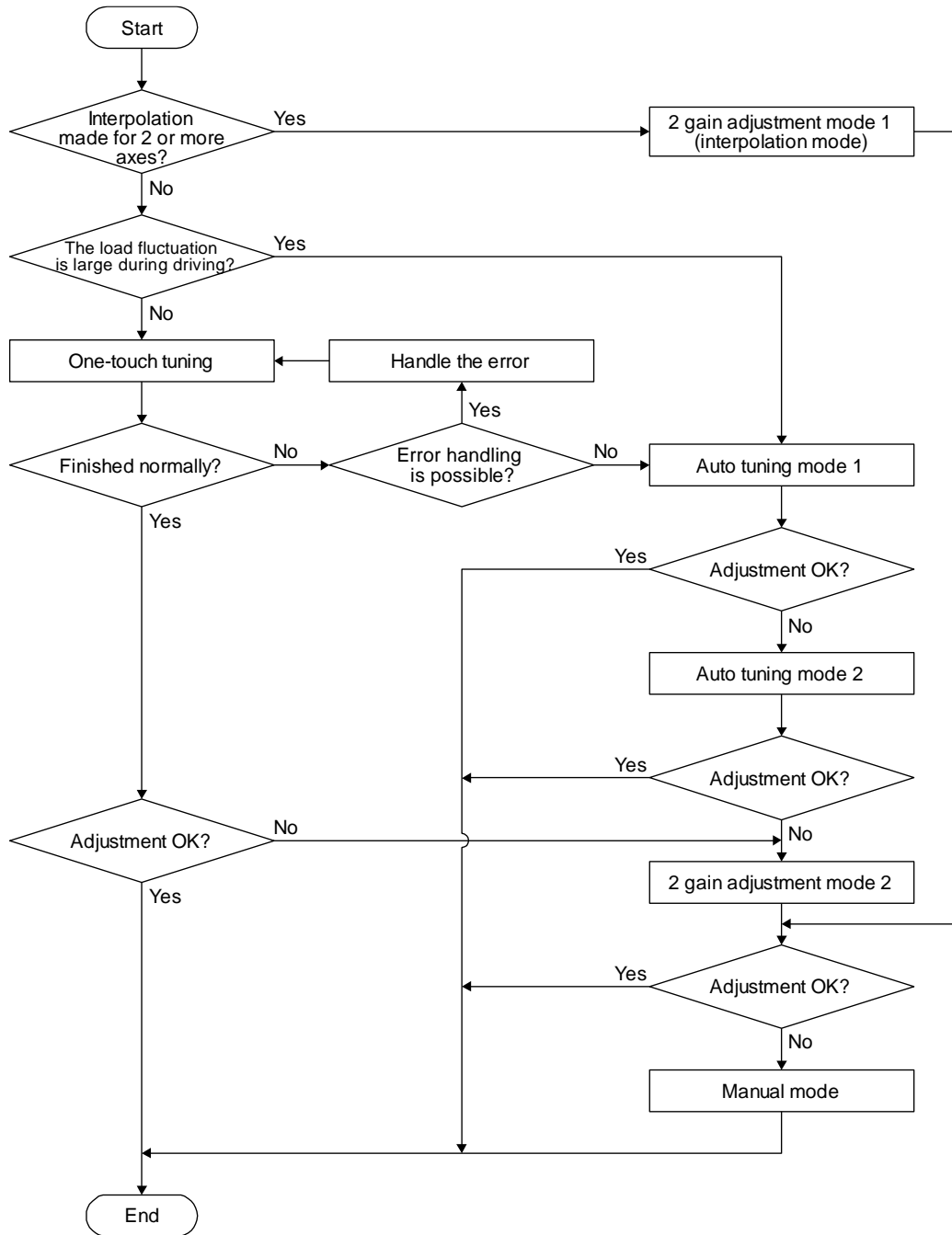

6.1.2 Adjustment using setup software (MR Configurator2™)

This section explains the functions and adjustment using the driver with setup software (MR Configurator2™).

Function	Description	Adjustment
Machine analyzer	With the machine and servo motor coupled, the characteristic of the mechanical system can be measured by giving a random vibration command from a personal computer to the servo and measuring the machine response.	You can grasp the machine resonance frequency and determine the notch frequency of the machine resonance suppression filter.

6. NORMAL GAIN ADJUSTMENT

6.2 One-touch tuning

POINT
<ul style="list-style-type: none"> ● After the one-touch tuning is completed, "Gain adjustment mode selection" in [Pr. PA08] will be set to "2 gain adjustment mode 2 (_ _ _ 4)". To estimate [Pr. PB06 Load to motor inertia ratio], set "Gain adjustment mode selection" in [Pr. PA08] to "Auto tuning mode 1 (_ _ _ 1)". ● When executing the one-touch tuning, check the [Pr. PA21 One-touch tuning function selection] is " _ _ _ 1" (initial value). ● For one-touch tuning via a network, refer to chapter 17.

Connect setup software (MR Configurator2™) and open the one-touch tuning window, and you can use the function. The following parameters are set automatically with one-touch tuning.

Table 6.1 List of parameters automatically set with one-touch tuning

Parameter	Symbol	Name	Parameter	Symbol	Name
PA08	ATU	Auto tuning mode	PB16	NHQ2	Notch shape selection 2
PA09	RSP	Auto tuning response	PB18	LPF	Low-pass filter setting
PB01	FILT	Adaptive tuning mode (adaptive filter II)	PB19	VRF11	Vibration suppression control 1 - Vibration frequency
PB02	VRFT	Vibration suppression control tuning mode (advanced vibration suppression control II)	PB20	VRF12	Vibration suppression control 1 - Resonance frequency
PB06	GD2	Load to motor inertia ratio	PB21	VRF13	Vibration suppression control 1 - Vibration frequency damping
PB07	PG1	Model loop gain	PB22	VRF14	Vibration suppression control 1 - Resonance frequency damping
PB08	PG2	Position loop gain	PB23	VFBF	Low-pass filter selection
PB09	VG2	Speed loop gain	PB47	NHQ3	Notch shape selection 3
PB10	VIC	Speed integral compensation	PB48	NH4	Machine resonance suppression filter 4
PB12	OVA	Overshoot amount compensation	PB49	NHQ4	Notch shape selection 4
PB13	NH1	Machine resonance suppression filter 1	PB51	NHQ5	Notch shape selection 5
PB14	NHQ1	Notch shape selection 1	PE41	EOP3	Function selection E-3
PB15	NH2	Machine resonance suppression filter 2			

6. NORMAL GAIN ADJUSTMENT

6.2.1 One-touch tuning flowchart

Make one-touch tuning as follows.

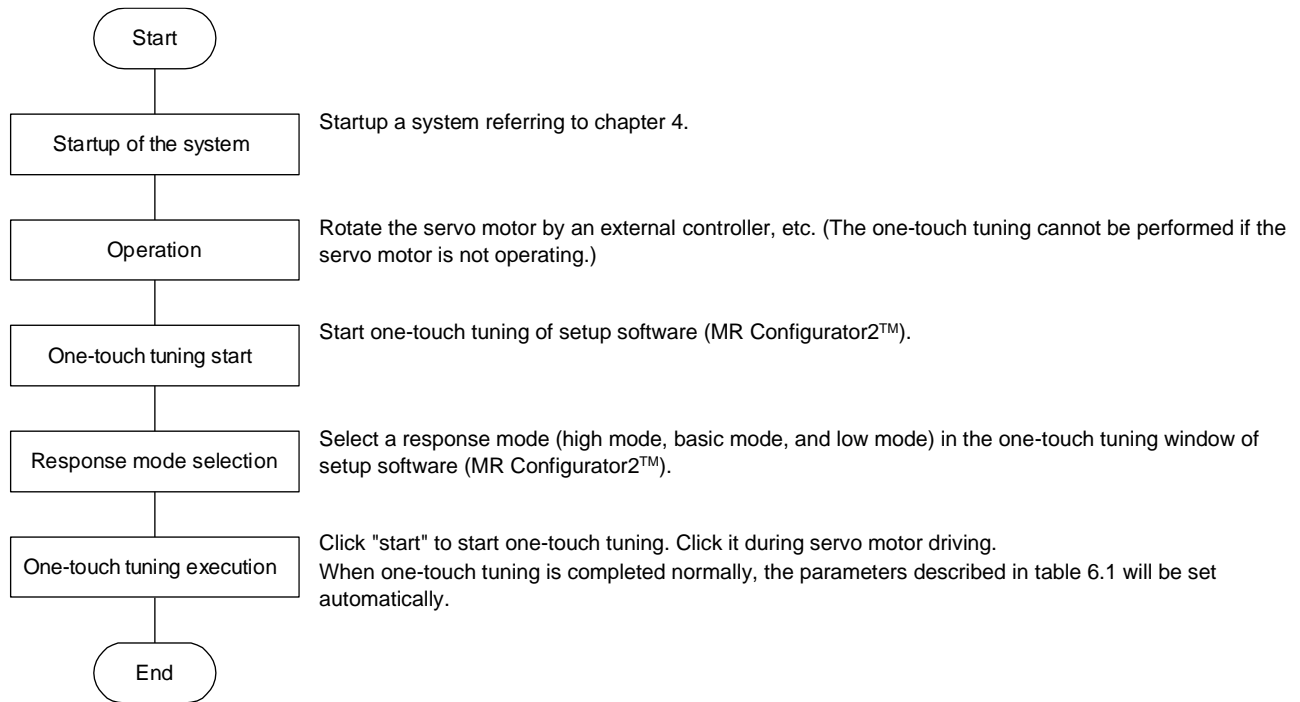

6. NORMAL GAIN ADJUSTMENT

6.2.2 Display transition and operation procedure of one-touch tuning

(1) Response mode selection

Select a response mode from 3 modes in the one-touch tuning window of setup software (MR Configurator2™).

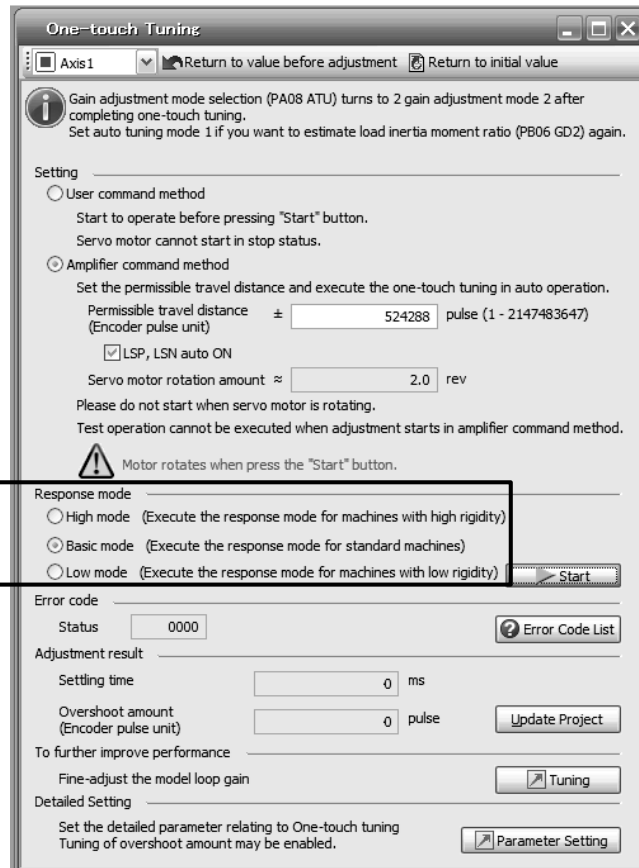

Response mode	Explanation
High mode	This mode is for high-rigid system. (Note)
Basic mode	This mode is for standard system.
Low mode	This mode is for low-rigid system.

Note. If the communication cycle of the controller is 2 ms or more, the gain may be adjusted higher. In this case, readjust the gain in the basic mode or the low mode.

6. NORMAL GAIN ADJUSTMENT

Refer to the following table for selecting a response mode.

Table 6.3 Guideline for response mode

Response mode			Response	Machine characteristic
Low mode	Basic mode	High mode		Guideline of corresponding machine
↑ ↓	↑ ↓	↑ ↓	Low response ↑ ↓ High response	<p>Arm robot</p> <p>General machine tool conveyor</p> <p>Precision working machine</p> <p>Inserter Mounter Bonder</p>

6. NORMAL GAIN ADJUSTMENT

(2) One-touch tuning execution

POINT

- For equipment in which overshoot during one-touch tuning is in the permissible level of the in-position range, changing the value of [Pr. PA25 One-touch tuning - Overshoot permissible level] will shorten the settling time and improve the response.

After the response mode is selected in (1) in this section, clicking "Start" will start one-touch tuning. If "Start" is clicked while the servo motor stops, "C002" or "C004" will be displayed at status in error code. (Refer to (4) in this section for error codes.)

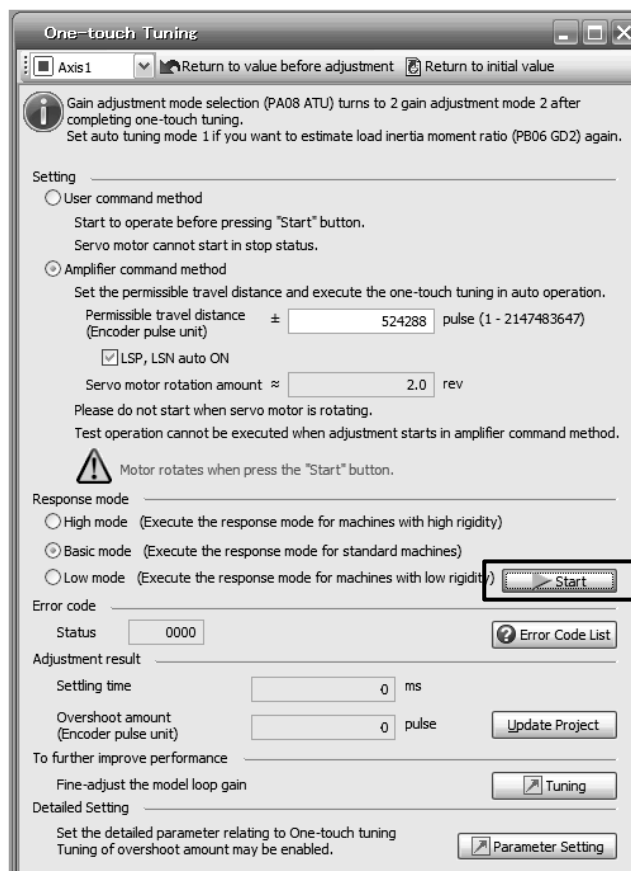

During processing of one-touch tuning, the progress will be displayed as follows. Tuning will be completed at 100%.

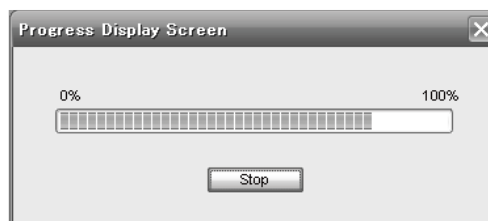

Completing the one-touch tuning will start writing tuning parameters to the driver, and the following window will be displayed. Select whether or not to reflect the tuning result in the project.

6. NORMAL GAIN ADJUSTMENT

(3) Stop of one-touch tuning

During one-touch tuning, pushing the stop button stops one-touch tuning.

If the one-touch tuning is stopped, "C 0 0 0" will be displayed at status in error code.

(4) If an error occurs

If a tuning error occurs during tuning, one-touch tuning will be forcibly terminated. With that, the following error code will be displayed in status. Check the cause of tuning error.

Error code	Name	Description	Action
C000	Tuning canceled	The stop button was pushed during one-touch tuning.	
C001	Overshoot exceeded	The overshoot amount is larger than the value set in [Pr. PA10 In-position range].	Increase the in-position range.
C002	Servo-off during tuning	The one-touch tuning was attempted during servo-off.	Perform the one-touch tuning after servo-on.
C003	Control mode error	The one-touch tuning was attempted while the torque mode was selected in the control modes.	Select the position mode or velocity mode for the control mode from the controller, and then make one-touch tuning.
C004	Time-out	1. 1 cycle time during the operation has been over 30 s.	Set the 1 cycle time during the operation to 30 s or less.
		2. The command speed is low.	Set the servo motor speed to 100 r/min or higher.
		3. The operation interval of the continuous operation is short.	Maintain the operation interval during motor driving about 200 ms.
C005	Load to motor inertia ratio misestimated	1. The estimation of the load to motor inertia ratio at one-touch tuning was a failure.	Drive the motor with meeting conditions as follows. <ul style="list-style-type: none"> • The acceleration/deceleration time constant to reach 2000 r/min is 5 s or less. • Servo motor speed is 150 r/min or higher. • The load to servo motor inertia ratio is 100 times or less. • The acceleration/deceleration torque is 10% or more of the rated torque.
		2. The load to motor inertia ratio was not estimated due to such as an oscillation.	Set to the auto tuning mode that does not estimate the load to motor inertia ratio as follows, and then execute the one-touch tuning. <ul style="list-style-type: none"> • Select "Auto tuning mode 2 (_ _ _ 2)", "Manual mode (_ _ _ 3)", or "2 gain adjustment mode 2 (_ _ _ 4)" of "Gain adjustment mode selection" in [Pr. PA08]. • Set [Pr. PB06 Load to motor inertia ratio/load to motor mass ratio] properly with manual setting.
C00F	One-touch tuning disabled	"One-touch tuning function selection" in [Pr. PA21] is "Disabled (_ _ _ 0)".	Select "Enabled (_ _ _ 1)".

6. NORMAL GAIN ADJUSTMENT

- (5) If an alarm occurs
If an alarm occurs during tuning, one-touch tuning will be forcibly terminated.
Remove the cause of the alarm and execute one-touch tuning again.
- (6) If a warning occurs
If a warning which continue the motor driving occurs during the tuning, one-touch tuning will be continued.
If a warning which does not continue the motor driving occurs during the tuning, one-touch tuning will be stopped.
- (7) Initializing one-touch tuning
You can clear the parameter values set with one-touch tuning.
Refer to table 6.1 for the parameters which you can clear.
Clicking "Return to value before adjustment" in the one-touch tuning window of setup software (MR Configurator2™) enables to return the parameter to the value before clicking "start".
In addition, pushing "Return to initial value" in the one-touch tuning window enables to rewrite the parameter to the initial value.

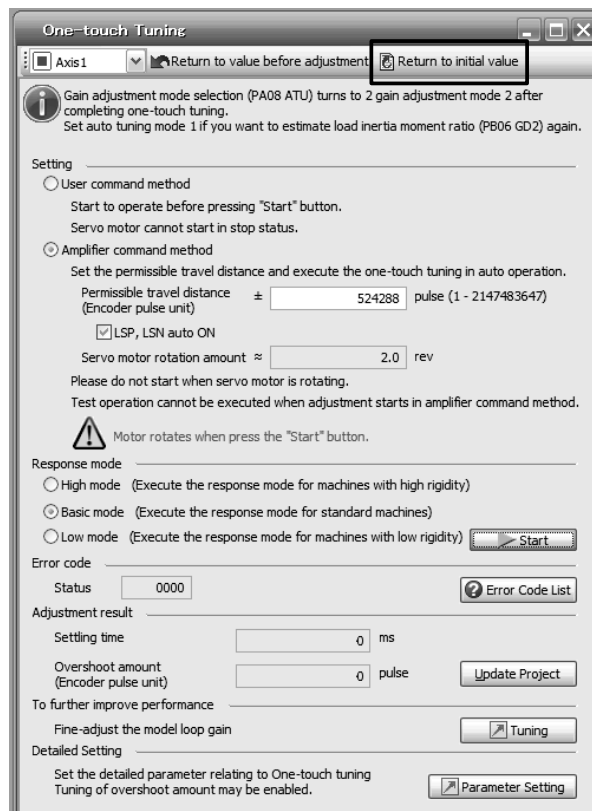

When the initialization of one-touch tuning is completed, the following window will be displayed.
(returning to initial value)



6. NORMAL GAIN ADJUSTMENT

6.2.3 Caution for one-touch tuning

- (1) The tuning is not available in the torque mode.
- (2) The one-touch tuning cannot be executed while an alarm or warning which does not continue the motor driving is occurring.
- (3) The tuning is not available during the following test operation mode.
 - (a) Output signal (DO) forced output
 - (b) Motor-less operation
- (4) If one-touch tuning is performed when the gain switching function is enabled, vibration and/or unusual noise may occur during the tuning.

6. NORMAL GAIN ADJUSTMENT

6.3 Auto tuning

6.3.1 Auto tuning mode

The driver has a real-time auto tuning function which estimates the machine characteristic (load to motor inertia ratio) in real time and automatically sets the optimum gains according to that value. This function permits ease of gain adjustment of the driver.

(1) Auto tuning mode 1

The driver is factory-set to the auto tuning mode 1.

In this mode, the load to motor inertia ratio of a machine is always estimated to set the optimum gains automatically.

The following parameters are automatically adjusted in the auto tuning mode 1.

Parameter	Symbol	Name
PB06	GD2	Load to motor inertia ratio
PB07	PG1	Model loop gain
PB08	PG2	Position loop gain
PB09	VG2	Speed loop gain
PB10	VIC	Speed integral compensation

POINT
<ul style="list-style-type: none">● The auto tuning mode 1 may not be performed properly if all of the following conditions are not satisfied.<ul style="list-style-type: none">▪ The acceleration/deceleration time constant to reach 2000 r/min is 5 s or less.▪ Speed is 150 r/min or higher.▪ The load to servo motor inertia ratio is 100 times or less.▪ The acceleration/deceleration torque is 10% or more of the rated torque.● Under operating conditions which will impose sudden disturbance torque during acceleration/deceleration or on a machine which is extremely loose, auto tuning may not function properly, either. In such cases, use the auto tuning mode 2 or manual mode to make gain adjustment.

(2) Auto tuning mode 2

Use the auto tuning mode 2 when proper gain adjustment cannot be made by auto tuning mode 1. Since the load to motor inertia ratio is not estimated in this mode, set the value of a correct load to motor inertia ratio in [Pr. PB06].

The following parameters are automatically adjusted in the auto tuning mode 2.

Parameter	Symbol	Name
PB07	PG1	Model loop gain
PB08	PG2	Position loop gain
PB09	VG2	Speed loop gain
PB10	VIC	Speed integral compensation

6. NORMAL GAIN ADJUSTMENT

6.3.2 Auto tuning mode basis

The block diagram of real-time auto tuning is shown below.

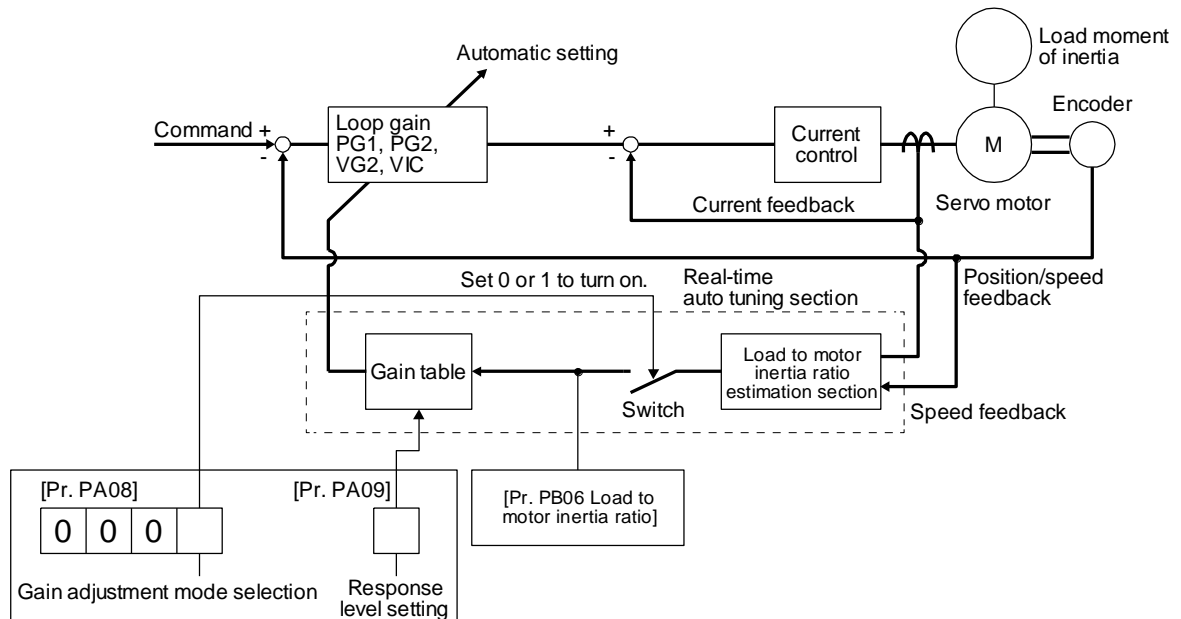

When a servo motor is accelerated/decelerated, the load to motor inertia ratio estimation section always estimates the load to motor inertia ratio from the current and speed of the servo motor. The results of estimation are written to [Pr. PB06 Load to motor inertia ratio]. These results can be confirmed on the status display screen of the setup software (MR Configurator2™).

If you have already known the value of the load to motor inertia ratio or failed to estimate, set "Gain adjustment mode selection" to "Auto tuning mode 2 (_ _ 2)" in [Pr. PA08] to stop the estimation (turning off the switch in above diagram), and set the load to motor inertia ratio ([Pr. PB06]) manually.

From the preset load to motor inertia ratio ([Pr. PB06]) value and response ([Pr. PA09]), the optimum loop gains are automatically set on the basis of the internal gain table.

The auto tuning results are saved in the EEP-ROM of the driver every 60 minutes since power-on. At power-on, auto tuning is performed with the value of each loop gain saved in the EEP-ROM being used as an initial value.

POINT
<ul style="list-style-type: none"> ● If sudden disturbance torque is imposed during operation, the load to motor inertia ratio may be misestimated temporarily. In such a case, set "Gain adjustment mode selection" to "Auto tuning mode 2 (_ _ 2)" in [Pr. PA08] and then set the correct load to motor inertia ratio in [Pr. PB06]. ● When any of the auto tuning mode 1 and auto tuning mode settings is changed to the manual mode 2 setting, the current loop gains and load to motor inertia ratio estimation value are saved in the EEP-ROM.

6. NORMAL GAIN ADJUSTMENT

6.3.3 Adjustment procedure by auto tuning

Since auto tuning is enabled before shipment from the factory, simply running the servo motor automatically sets the optimum gains that match the machine. Merely changing the response level setting value as required completes the adjustment. The adjustment procedure is as follows.

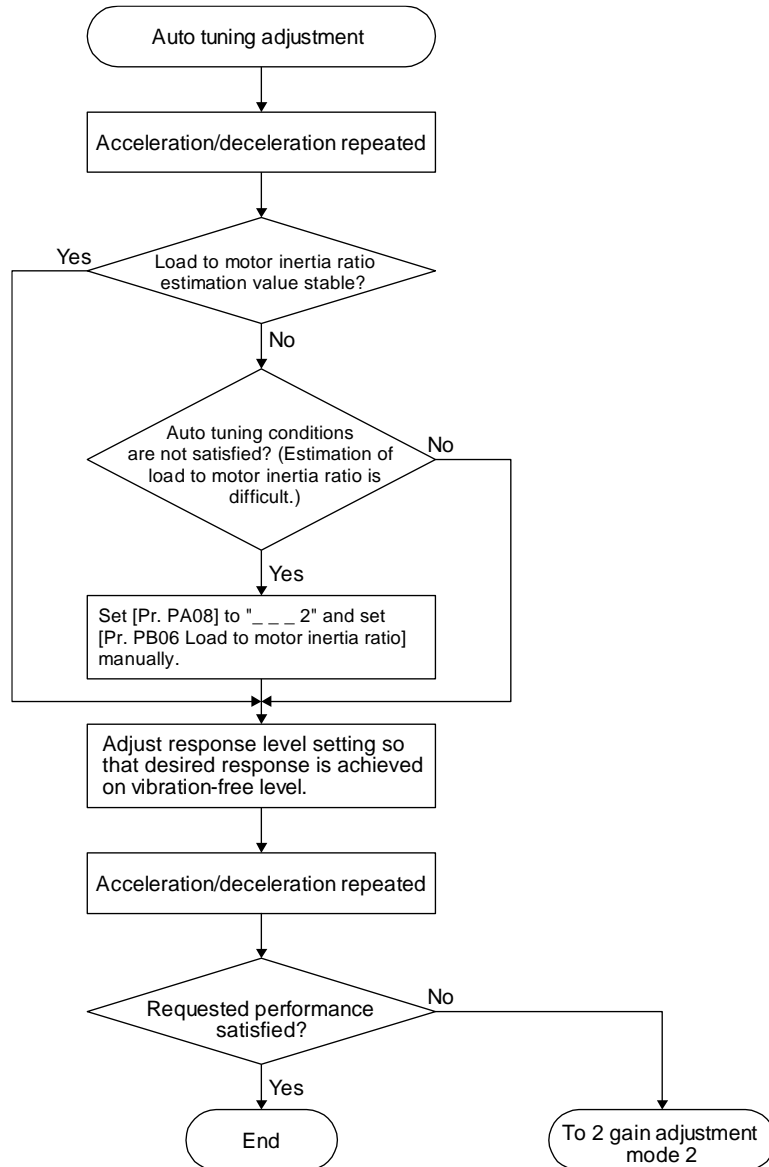

6. NORMAL GAIN ADJUSTMENT

6.3.4 Response level setting in auto tuning mode

Set the response of the whole servo system by [Pr. PA09]. As the response level setting is increased, trackability to a command improves and settling time decreases, but setting the response level too high will generate vibration.

Set a value to obtain the desired response level within the vibration-free range.

If the response level setting cannot be increased up to the desired response because of machine resonance beyond 100 Hz, filter tuning mode selection in [Pr. PB01] or machine resonance suppression filter in [Pr. PB13] to [Pr. PB16], [Pr. PB46] to [Pr. PB51] may be used to suppress machine resonance. Suppressing machine resonance may allow the response level setting to increase. Refer to section 7.1.1 and 7.1.2 for settings of the adaptive tuning mode and machine resonance suppression filter.

[Pr. PA09]

Setting value	Machine characteristic		Setting value	Machine characteristic		
	Response	Guideline for machine resonance frequency [Hz]		Response	Guideline for machine resonance frequency [Hz]	
1	Low response ↑	2.7	21	Middle response ↑	67.1	
2		3.6	22		75.6	
3		4.9	23		85.2	
4		6.6	24		95.9	
5		10.0	25		108.0	
6		11.3	26		121.7	
7		12.7	27		137.1	
8		14.3	28		154.4	
9		16.1	29		173.9	
10		18.1	30		195.9	
11		20.4	31		220.6	
12		23.0	32		248.5	
13		25.9	33		279.9	
14		29.2	34		315.3	
15		32.9	35		355.1	
16		37.0	36		400.0	
17		41.7	37		446.6	
18		47.0	38		501.2	
19	Middle response ↓	52.9	39		High response ↓	571.5
20		59.6	40			642.7

6. NORMAL GAIN ADJUSTMENT

6.4 Manual mode

If you are not satisfied with the adjustment of auto tuning, you can adjust all gains manually.

POINT
<p>● If machine resonance occurs, filter tuning mode selection in [Pr. PB01] or machine resonance suppression filter in [Pr. PB13] to [Pr. PB16] and [Pr. PB46] to [Pr. PB51] may be used to suppress machine resonance. (Refer to section 7.1.1 to 7.1.2.)</p>

(1) For speed control

(a) Parameter

The following parameters are used for gain adjustment.

Parameter	Symbol	Name
PB06	GD2	Load to motor inertia ratio
PB07	PG1	Model loop gain
PB09	VG2	Speed loop gain
PB10	VIC	Speed integral compensation

(b) Adjustment procedure

Step	Operation	Description
1	Brief-adjust with auto tuning. Refer to section 6.2.3.	
2	Change the setting of auto tuning to the manual mode ([Pr. PA08]: ___ 3).	
3	Set the estimated value to the load to motor inertia ratio. (If the estimate value with auto tuning is correct, setting change is not required.)	
4	Set a small value to the model loop gain. Set a large value to the speed integral compensation.	
5	Increase the speed loop gain within the vibration- and unusual noise-free range, and return slightly if vibration takes place.	Increase the speed loop gain.
6	Decrease the speed integral compensation within the vibration-free range, and return slightly if vibration takes place.	Decrease the time constant of the speed integral compensation.
7	Increase the model loop gain, and return slightly if overshoot takes place.	Increase the model loop gain.
8	If the gains cannot be increased due to mechanical system resonance or the like and the desired response cannot be achieved, response may be increased by suppressing resonance with the adaptive tuning mode or machine resonance suppression filter and then executing steps 3 to 7.	Suppression of machine resonance Refer to section 7.2 and 7.3.
9	While checking the motor status, fine-adjust each gain.	Fine adjustment

6. NORMAL GAIN ADJUSTMENT

(c) Parameter adjustment

1) [Pr. PB09 Speed loop gain]

This parameter determines the response level of the speed control loop. Increasing this value enhances response but a too high value will make the mechanical system liable to vibrate. The actual response frequency of the speed loop is as indicated in the following expression.

$$\text{Speed loop response frequency [Hz]} = \frac{\text{Speed loop gain}}{(1 + \text{Load to motor inertia ratio}) \times 2\pi}$$

2) [Pr. PB10 Speed integral compensation]

To eliminate stationary deviation against a command, the speed control loop is under proportional integral control. For the speed integral compensation, set the time constant of this integral control. Increasing the setting lowers the response level. However, if the load to motor inertia ratio is large or the mechanical system has any vibratory element, the mechanical system is liable to vibrate unless the setting is increased to some degree. The guideline is as indicated in the following expression.

$$\text{Speed integral compensation setting [ms]} \geq \frac{2000 \text{ to } 3000}{\text{Speed loop gain}/(1 + \text{Load to motor inertia ratio})}$$

3) [Pr. PB07 Model loop gain]

This parameter determines the response level to a speed command. Increasing the value improves trackability to a speed command, but a too high value will make overshoot liable to occur at settling.

$$\text{Model loop gain guideline} \leq \frac{\text{Speed loop gain}}{(1 + \text{Load to motor inertia ratio})} \times \left(\frac{1}{4} \text{ to } \frac{1}{8} \right)$$

(2) For position control

(a) Parameter

The following parameters are used for gain adjustment.

Parameter	Symbol	Name
PB06	GD2	Load to motor inertia ratio
PB07	PG1	Model loop gain
PB08	PG2	Position loop gain
PB09	VG2	Speed loop gain
PB10	VIC	Speed integral compensation

6. NORMAL GAIN ADJUSTMENT

(b) Adjustment procedure

Step	Operation	Description
1	Brief-adjust with auto tuning. Refer to section 6.2.3.	
2	Change the setting of auto tuning to the manual mode ([Pr. PA08]: __ _ 3).	
3	Set the estimated value to the load to motor inertia ratio. (If the estimate value with auto tuning is correct, setting change is not required.)	
4	Set a small value to the model loop gain and the position loop gain. Set a large value to the speed integral compensation.	
5	Increase the speed loop gain within the vibration- and unusual noise-free range, and return slightly if vibration takes place.	Increase the speed loop gain.
6	Decrease the speed integral compensation within the vibration-free range, and return slightly if vibration takes place.	Decrease the time constant of the speed integral compensation.
7	Increase the position loop gain, and return slightly if vibration takes place.	Increase the position loop gain.
8	Increase the model loop gain, and return slightly if overshoot takes place.	Increase the model loop gain.
9	If the gains cannot be increased due to mechanical system resonance or the like and the desired response cannot be achieved, response may be increased by suppressing resonance with the adaptive tuning mode or machine resonance suppression filter and then executing steps 3 to 8.	Suppression of machine resonance Refer to section 7.2 and 7.3.
10	While checking the settling characteristic and motor status, fine-adjust each gain.	Fine adjustment

(c) Parameter adjustment

1) [Pr. PB09 Speed loop gain]

This parameter determines the response level of the speed control loop. Increasing this value enhances response but a too high value will make the mechanical system liable to vibrate. The actual response frequency of the speed loop is as indicated in the following expression.

$$\text{Speed loop response frequency [Hz]} = \frac{\text{Speed loop gain}}{(1 + \text{Load to motor inertia ratio}) \times 2\pi}$$

2) [Pr. PB10 Speed integral compensation]

To eliminate stationary deviation against a command, the speed control loop is under proportional integral control. For the speed integral compensation, set the time constant of this integral control. Increasing the setting lowers the response level. However, if the load to motor inertia ratio is large or the mechanical system has any vibratory element, the mechanical system is liable to vibrate unless the setting is increased to some degree. The guideline is as indicated in the following expression.

$$\text{Speed integral compensation setting [ms]} \geq \frac{2000 \text{ to } 3000}{\text{Speed loop gain}/(1 + \text{Load to motor inertia ratio})}$$

6. NORMAL GAIN ADJUSTMENT

3) [Pr. PB08 Position loop gain]

This parameter determines the response level to a disturbance to the position control loop. Increasing the value increases the response level to the disturbance, but a too high value will increase vibration of the mechanical system.

$$\text{Position loop gain guideline} \leq \frac{\text{Speed loop gain}}{(1 + \text{Load to motor inertia ratio})} \times \left(\frac{1}{4} \text{ to } \frac{1}{8} \right)$$

4) [Pr. PB07 Model loop gain]

This parameter determines the response level to a position command. Increasing the value improves trackability to a position command, but a too high value will make overshoot liable to occur at settling.

$$\text{Model loop gain guideline} \leq \frac{\text{Speed loop gain}}{(1 + \text{Load to motor inertia ratio})} \times \left(\frac{1}{4} \text{ to } \frac{1}{8} \right)$$

6. NORMAL GAIN ADJUSTMENT

6.5 2gain adjustment mode

The 2 gain adjustment mode is used to match the position loop gains of the axes when performing the interpolation operation of servo motors of two or more axes for an X-Y table or the like. In this mode, manually set the model loop gain that determines command trackability. Other parameters for gain adjustment are set automatically.

(1) 2 gain adjustment mode 1 (interpolation mode)

The 2 gain adjustment mode 1 manually set the model loop gain that determines command trackability. The mode constantly estimates the load to motor inertia ratio, and automatically set other parameters for gain adjustment to optimum gains using auto tuning response.

The following parameters are used for 2 gain adjustment mode 1.

(a) Automatically adjusted parameter

The following parameters are automatically adjusted by auto tuning.

Parameter	Symbol	Name
PB06	GD2	Load to motor inertia ratio
PB08	PG2	Position loop gain
PB09	VG2	Speed loop gain
PB10	VIC	Speed integral compensation

(b) Manually adjusted parameter

The following parameters are adjustable manually.

Parameter	Symbol	Name
PA09	RSP	Auto tuning response
PB07	PG1	Model loop gain

(2) 2 gain adjustment mode 2

Use 2 gain adjustment mode 2 when proper gain adjustment cannot be made with 2 gain adjustment mode 1. Since the load to motor inertia ratio is not estimated in this mode, set the value of a proper load to motor inertia ratio in [Pr. PB06].

The following parameters are used for 2 gain adjustment mode 2.

(a) Automatically adjusted parameter

The following parameters are automatically adjusted by auto tuning.

Parameter	Symbol	Name
PB08	PG2	Position loop gain
PB09	VG2	Speed loop gain
PB10	VIC	Speed integral compensation

(b) Manually adjusted parameter

The following parameters are adjustable manually.

Parameter	Symbol	Name
PA09	RSP	Auto tuning response
PB06	GD2	Load to motor inertia ratio
PB07	PG1	Model loop gain

6. NORMAL GAIN ADJUSTMENT

(3) Adjustment procedure of 2 gain adjustment mode

POINT	
	● Set the same value in [Pr. PB07 Model loop gain] for the axis used in 2 gain adjustment mode.

Step	Operation	Description
1	Set to the auto tuning mode.	Select the auto tuning mode 1.
2	During operation, increase the response level setting value in [Pr. PA09], and return the setting if vibration occurs.	Adjustment in auto tuning mode 1.
3	Check value of the model loop gain and the load to motor inertia ratio in advance.	Check the upper setting limits.
4	Set the 2 gain adjustment mode 1 ([Pr. PA08]: _ _ _ 0).	Select the 2 gain adjustment mode 1 (interpolation mode).
5	When the load to motor inertia ratio is different from the design value, select the 2 gain adjustment mode 2 ([Pr. PA08]: _ _ _ 4) and then set the load to motor inertia ratio manually in [Pr. PB06].	Check the load to motor inertia ratio.
6	Set the model loop gain of all the axes to be interpolated to the same value. At that time, adjust to the setting value of the axis, which has the smallest model loop gain.	Set model loop gain.
7	Considering the interpolation characteristic and motor status, fine-adjust the model loop gain and response level setting.	Fine adjustment

(4) Parameter adjustment

[Pr. PB07 Model loop gain]

This parameter determines the response level of the position control loop. Increasing the value improves trackability to a position command, but a too high value will make overshoot liable to occur at settling. Number of droop pulses is determined by the following expression.

$$\text{Number of droop pulses [pulse]} = \frac{\text{Position command frequency [pulse/s]}}{\text{Model loop gain setting}}$$

Position command frequency differs depending on the operation mode.

$$\begin{aligned} &\text{Position command frequency} \\ &= \frac{\text{Speed [r/min]}}{60} \times \text{Encoder resolution (number of pulses per servo motor revolution)} \end{aligned}$$

7. SPECIAL ADJUSTMENT FUNCTIONS

7. SPECIAL ADJUSTMENT FUNCTIONS	2
7.1 Filter setting.....	2
7.1.1 Machine resonance suppression filter.....	2
7.1.2 Adaptive filter II.....	5
7.1.3 Shaft resonance suppression filter.....	7
7.1.4 Low-pass filter	8
7.1.5 Advanced vibration suppression control II	8
7.1.6 Command notch filter	13
7.2 Gain switching function	14
7.2.1 Applications	14
7.2.2 Function block diagram	15
7.2.3 Parameter.....	16
7.2.4 Gain switching procedure.....	19
7.3 Tough drive function.....	23
7.3.1 Vibration tough drive function.....	23
7.3.2 Instantaneous power failure tough drive function.....	25
7.4 Compliance with SEMI-F47 standard	29
7.5 Model adaptive control disabled	31
7.6 Lost motion compensation function	32
7.7 Super trace control.....	35

7. SPECIAL ADJUSTMENT FUNCTIONS

7. SPECIAL ADJUSTMENT FUNCTIONS

POINT
<ul style="list-style-type: none"> ● The functions given in this chapter need not be used normally. Use them if you are not satisfied with the machine status after making adjustment in the methods in chapter 6.

7.1 Filter setting

The following filters are available with LECSND□-T□ drivers.

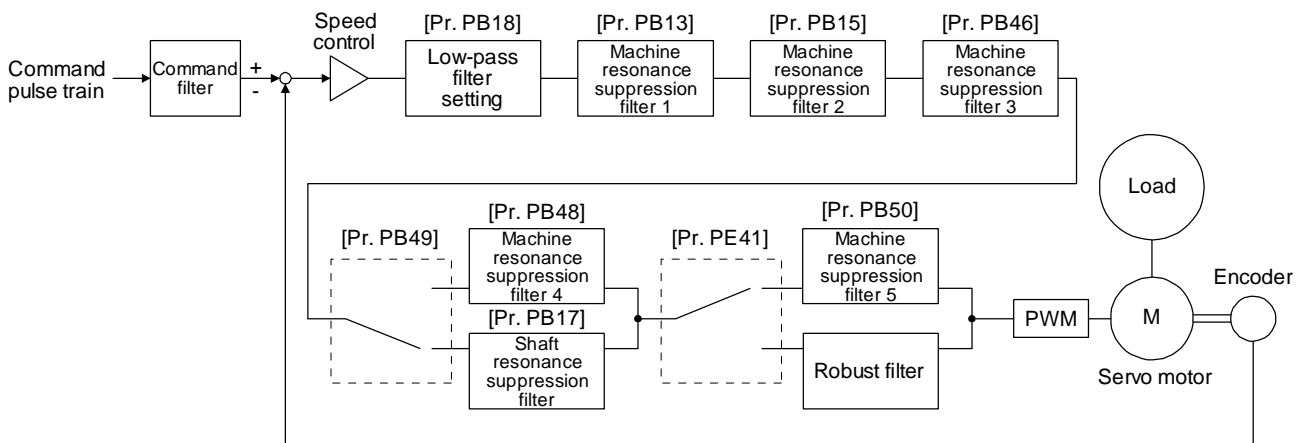

7.1.1 Machine resonance suppression filter

POINT
<ul style="list-style-type: none"> ● The machine resonance suppression filter is a delay factor for the servo system. Therefore, vibration may increase if you set an incorrect resonance frequency or set notch characteristics too deep or too wide. ● If the frequency of machine resonance is unknown, decrease the notch frequency from higher to lower ones in order. The optimum notch frequency is set at the point where vibration is minimal. ● A deeper notch has a higher effect on machine resonance suppression but increases a phase delay and may increase vibration. ● A deeper notch has a higher effect on machine resonance suppression but increases a phase delay and may increase vibration. ● The machine characteristic can be grasped beforehand by the machine analyzer on setup software (MR Configurator2™). This allows the required notch frequency and notch characteristics to be determined.

If a mechanical system has a natural resonance point, increasing the servo system response level may cause the mechanical system to produce resonance (vibration or unusual noise) at that resonance frequency. Using the machine resonance suppression filter and adaptive tuning can suppress the resonance of the mechanical system. The setting range is 10 Hz to 4500 Hz.

7. SPECIAL ADJUSTMENT FUNCTIONS

(1) Function

The machine resonance suppression filter is a filter function (notch filter) which decreases the gain of the specific frequency to suppress the resonance of the mechanical system. You can set the gain decreasing frequency (notch frequency), gain decreasing depth and width.

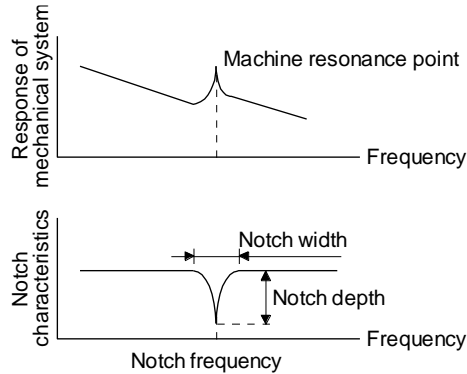

You can set five machine resonance suppression filters at most.

Filter	Setting parameter	Precaution	Parameter that is reset with vibration tough drive function	Parameter automatically adjusted with one-touch tuning
Machine resonance suppression filter 1	PB01/PB13/PB14	The filter can be set automatically with "Filter tuning mode selection" in [Pr. PB01].	PB13	PB01/PB13/PB14
Machine resonance suppression filter 2	PB15/PB16		PB15	PB15/PB16
Machine resonance suppression filter 3	PB46/PB47			PB46/PB47
Machine resonance suppression filter 4	PB48/PB49	Enabling the machine resonance suppression filter 4 disables the shaft resonance suppression filter. Using the shaft resonance suppression filter is recommended because it is adjusted properly depending on the usage situation. The shaft resonance suppression filter is enabled for the initial setting.		PB48/PB49
Machine resonance suppression filter 5	PB50/PB51	Enabling the robust filter disables the machine resonance suppression filter 5. The robust filter is disabled for the initial setting.		PB51

7. SPECIAL ADJUSTMENT FUNCTIONS

(2) Parameter

(a) Machine resonance suppression filter 1 ([Pr. PB13] and [Pr. PB14])

Set the notch frequency, notch depth and notch width of the machine resonance suppression filter 1 ([Pr. PB13] and [Pr. PB14])

When you select "Manual setting (_ _ _ 2)" of "Filter tuning mode selection" in [Pr. PB01], the setting of the machine resonance suppression filter 1 is enabled.

(b) Machine resonance suppression filter 2 ([Pr. PB15] and [Pr. PB16])

To use this filter, select "Enabled (_ _ _ 1)" of "Machine resonance suppression filter 2 selection" in [Pr. PB16].

How to set the machine resonance suppression filter 2 ([Pr. PB15] and [Pr. PB16]) is the same as for the machine resonance suppression filter 1 ([Pr. PB13] and [Pr. PB14]).

(c) Machine resonance suppression filter 3 ([Pr. PB46] and [Pr. PB47])

To use this filter, select "Enabled (_ _ _ 1)" of "Machine resonance suppression filter 3 selection" in [Pr. PB47].

How to set the machine resonance suppression filter 3 ([Pr. PB46] and [Pr. PB47]) is the same as for the machine resonance suppression filter 1 ([Pr. PB13] and [Pr. PB14]).

(d) Machine resonance suppression filter 4 ([Pr. PB48] and [Pr. PB49])

To use this filter, select "Enabled (_ _ _ 1)" of "Machine resonance suppression filter 4 selection" in [Pr. PB49]. However, enabling the machine resonance suppression filter 4 disables the shaft resonance suppression filter.

How to set the machine resonance suppression filter 4 ([Pr. PB48] and [Pr. PB49]) is the same as for the machine resonance suppression filter 1 ([Pr. PB13] and [Pr. PB14]).

(e) Machine resonance suppression filter 5 ([Pr. PB50] and [Pr. PB51])

To use this filter, select "Enabled (_ _ _ 1)" of "Machine resonance suppression filter 5 selection" in [Pr. PB51]. However, enabling the robust filter ([Pr. PE41: _ _ _ 1]) disables the machine resonance suppression filter 5.

How to set the machine resonance suppression filter 5 ([Pr. PB50] and [Pr. PB51]) is the same as for the machine resonance suppression filter 1 ([Pr. PB13] and [Pr. PB14]).

7. SPECIAL ADJUSTMENT FUNCTIONS

7.1.2 Adaptive filter II

POINT
<ul style="list-style-type: none"> ● The machine resonance frequency which adaptive filter II (adaptive tuning) can respond to is about 100 Hz to 2.25 kHz. As for the resonance frequency out of the range, set manually. ● When adaptive tuning is executed, vibration sound increases as an excitation signal is forcibly applied for several seconds. ● When adaptive tuning is executed, machine resonance is detected for a maximum of 10 seconds and a filter is generated. After filter generation, the adaptive tuning mode automatically shifts to the manual setting. ● Adaptive tuning generates the optimum filter with the currently set control gains. If vibration occurs when the response setting is increased, execute adaptive tuning again. ● During adaptive tuning, a filter having the best notch depth at the set control gain is generated. To allow a filter margin against machine resonance, increase the notch depth in the manual setting. ● Adaptive vibration suppression control may provide no effect on a mechanical system which has complex resonance characteristics.

(1) Function

Adaptive filter II (adaptive tuning) is a function in which the driver detects machine vibration for a predetermined period of time and sets the filter characteristics automatically to suppress mechanical system vibration. Since the filter characteristics (frequency, depth) are set automatically, you need not be conscious of the resonance frequency of a mechanical system.

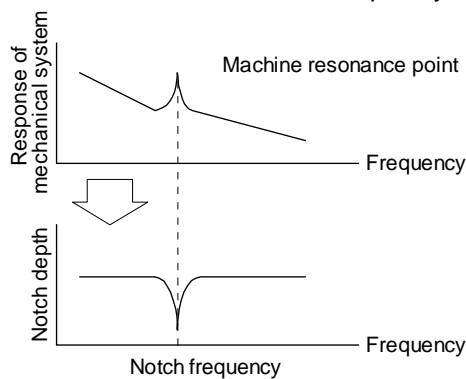

When machine resonance is large and frequency is low

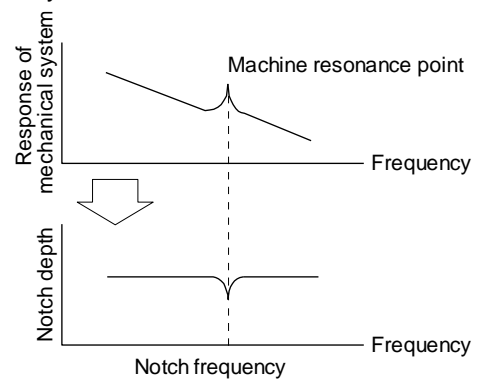

When machine resonance is small and frequency is high

(2) Parameter

Select how to set the filter tuning in [Pr. PB01 Adaptive tuning mode (adaptive filter II)].

[Pr. PB01]

0	0	0	
---	---	---	--

Filter tuning mode selection

Setting value	Filter tuning mode selection	Automatically set parameter
0	Disabled	
1	Automatic setting	PB13/PB14
2	Manual setting	

7. SPECIAL ADJUSTMENT FUNCTIONS

(3) Adaptive tuning mode procedure

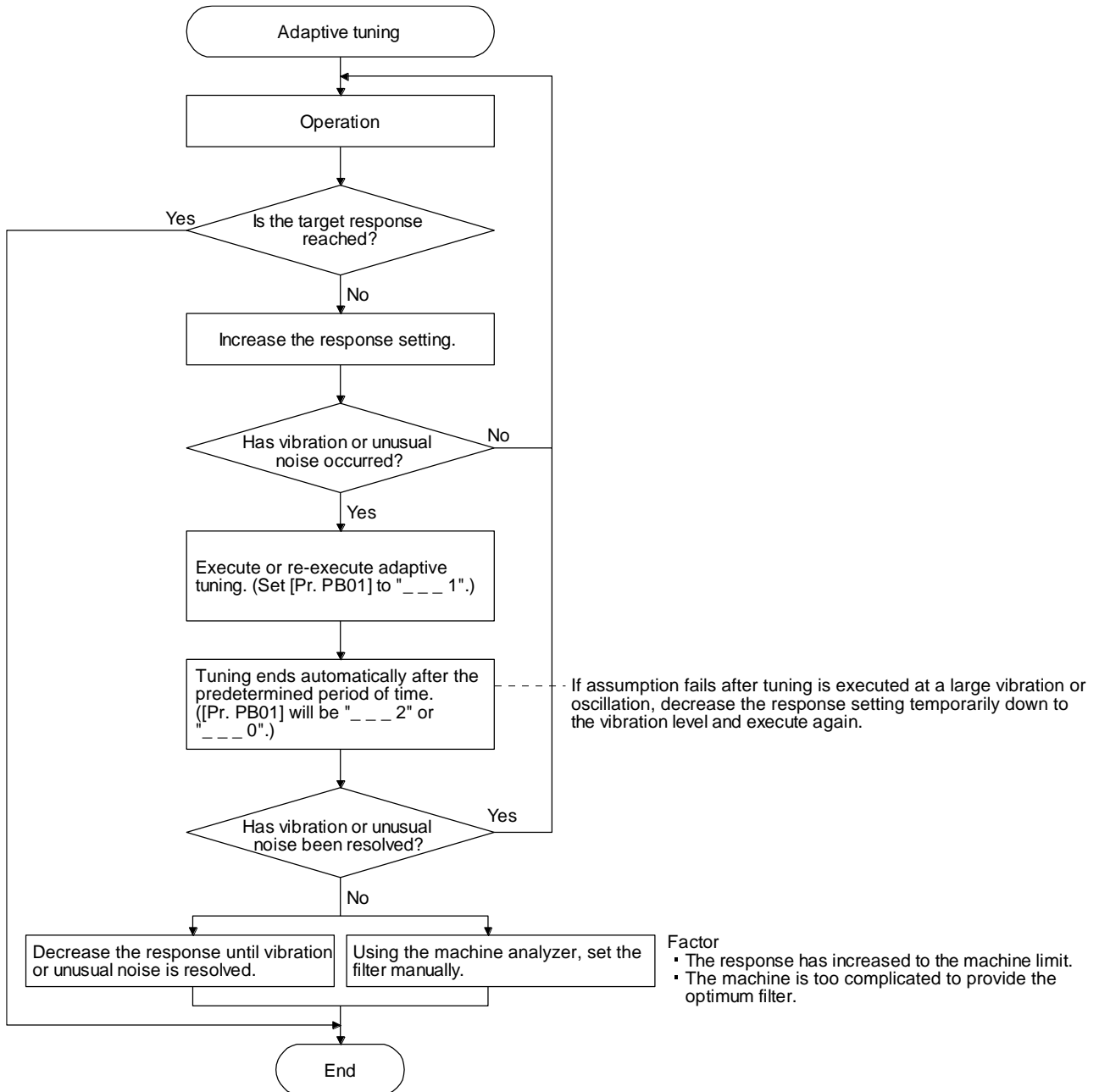

7. SPECIAL ADJUSTMENT FUNCTIONS

7.1.3 Shaft resonance suppression filter

POINT
<p>● This filter is set properly by default according to servo motor you use and load moment of inertia. It is recommended that [Pr. PB23] be set to "___ 0" (automatic setting) because changing "Shaft resonance suppression filter selection" in [Pr. PB23] or [Pr. PB17 Shaft resonance suppression filter] may lower the performance.</p>

(1) Function

When a load is mounted to the servo motor shaft, resonance by shaft torsion during driving may generate a mechanical vibration at high frequency. The shaft resonance suppression filter suppresses the vibration.

When you select "Automatic setting", the filter will be set automatically on the basis of the motor you use and the load to motor inertia ratio. The disabled setting increases the response of the driver for high resonance frequency.

(2) Parameter

Set "Shaft resonance suppression filter selection" in [Pr. PB23].

[Pr. PB23]

0	0	0	
---	---	---	--

Shaft resonance suppression filter selection
 0: Automatic setting
 1: Manual setting
 2: Disabled

To set [Pr. PB17 Shaft resonance suppression filter] automatically, select "Automatic setting".

To set [Pr. PB17 Shaft resonance suppression filter] manually, select "Manual setting". The setting values are as follows.

Shaft resonance suppression filter setting frequency selection

Setting value	Frequency [Hz]	Setting value	Frequency [Hz]
__ 0 0	Disabled	__ 1 0	562
__ 0 1	Disabled	__ 1 1	529
__ 0 2	4500	__ 1 2	500
__ 0 3	3000	__ 1 3	473
__ 0 4	2250	__ 1 4	450
__ 0 5	1800	__ 1 5	428
__ 0 6	1500	__ 1 6	409
__ 0 7	1285	__ 1 7	391
__ 0 8	1125	__ 1 8	375
__ 0 9	1000	__ 1 9	360
__ 0 A	900	__ 1 A	346
__ 0 B	818	__ 1 B	333
__ 0 C	750	__ 1 C	321
__ 0 D	692	__ 1 D	310
__ 0 E	642	__ 1 E	300
__ 0 F	600	__ 1 F	290

7. SPECIAL ADJUSTMENT FUNCTIONS

7.1.4 Low-pass filter

(1) Function

When a ball screw or the like is used, resonance of high frequency may occur as the response level of the servo system is increased. To prevent this, the low-pass filter is enabled for a torque command as a default. The filter frequency of the low-pass filter is automatically adjusted to the value in the following equation.

$$\text{Filter frequency ([rad/s])} = \frac{VG2}{1 + GD2} \times 10$$

However, when an automatically adjusted value is smaller than VG2, the filter frequency will be the VG2 value.

To set [Pr. PB18] manually, select "Manual setting (_ _ 1 _)" of "Low-pass filter selection" in [Pr. PB23].

(2) Parameter

Set "Low-pass filter selection" in [Pr. PB23].

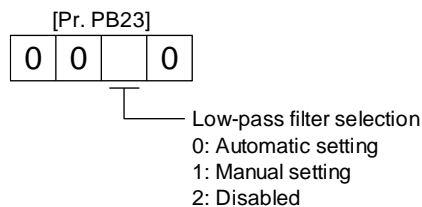

7.1.5 Advanced vibration suppression control II

POINT	
●	The function is enabled when "Gain adjustment mode selection" in [Pr. PA08] is "Auto tuning mode 2 (_ _ _ 2)", "Manual mode (_ _ _ 3)", or "2 gain adjustment mode 2 (_ _ _ 4)".
●	The machine resonance frequency supported in the vibration suppression control tuning mode is 1.0 Hz to 100.0 Hz. As for the vibration out of the range, set manually.
●	Stop the servo motor before changing the vibration suppression control-related parameters. Otherwise, it may cause an unexpected operation.
●	For positioning operation during execution of vibration suppression control tuning, provide a stop time to ensure a stop after vibration damping.
●	Vibration suppression control tuning may not make normal estimation if the residual vibration at the servo motor side is small.
●	Vibration suppression control tuning sets the optimum parameter with the currently set control gains. When the response setting is increased, set vibration suppression control tuning again.
●	When using the vibration suppression control 2, set " _ _ _ 1" in [Pr. PA24].

7. SPECIAL ADJUSTMENT FUNCTIONS

(1) Function

Vibration suppression control is used to further suppress load-side vibration, such as work-side vibration and base shake. The servo motor-side operation is adjusted for positioning so that the machine does not vibrate.

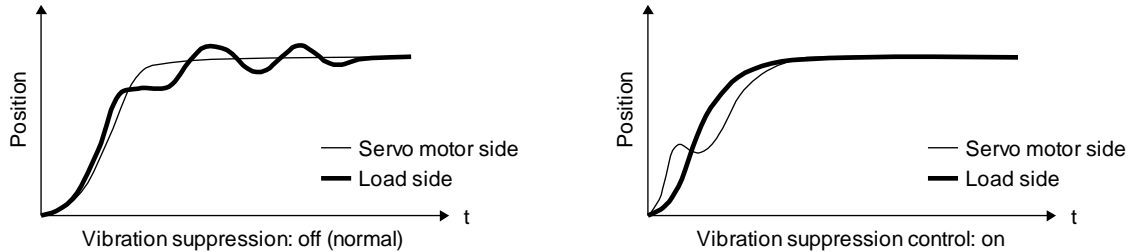

When the advanced vibration suppression control II ([Pr. PB02 Vibration suppression control tuning mode]) is executed, the vibration frequency at load side is automatically estimated to suppress machine side vibration two times at most.

In the vibration suppression control tuning mode, this mode shifts to the manual setting after the positioning operation is performed the predetermined number of times. For manual setting, adjust the vibration suppression control 1 with [Pr. PB19] to [Pr. PB22] and vibration suppression control 2 with [Pr. PB52] to [Pr. PB55].

(2) Parameter

Set [Pr. PB02 Vibration suppression control tuning mode (advanced vibration suppression control II)]. When you use a vibration suppression control, set "Vibration suppression control 1 tuning mode selection". When you use two vibration suppression controls, set "Vibration suppression control 2 tuning mode selection" in addition.

[Pr. PB02]		
0	0	
Vibration suppression control 1 tuning mode		
Setting value	Vibration suppression control 1 tuning mode selection	Automatically set parameter
_ _ _ 0	Disabled	
_ _ _ 1	Automatic setting	PB19/PB20/PB21/PB22
_ _ _ 2	Manual setting	
Vibration suppression control 2 tuning mode		
Setting value	Vibration suppression control 2 tuning mode selection	Automatically set parameter
_ _ 0 _	Disabled	
_ _ 1 _	Automatic setting	PB52/PB53/PB54/PB55
_ _ 2 _	Manual setting	

7. SPECIAL ADJUSTMENT FUNCTIONS

(3) Vibration suppression control tuning procedure

The following flow chart is for the vibration suppression control 1. For the vibration suppression control 2, set " _ _ 1 _ " in [Pr. PB02] to execute the vibration suppression control tuning.

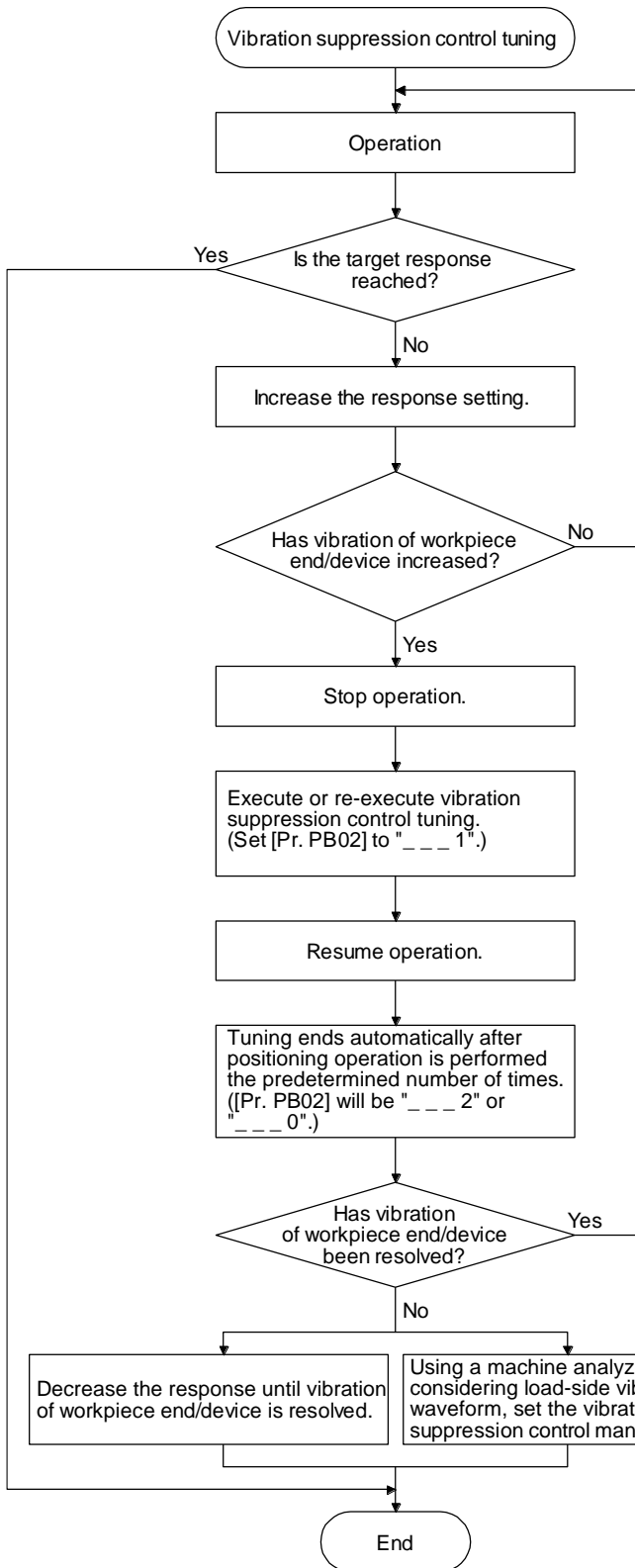

Factor

- Estimation cannot be made as load-side vibration has not been transmitted to the servo motor side.
- The response of the model loop gain has increased to the load-side vibration frequency (vibration suppression control limit).

7. SPECIAL ADJUSTMENT FUNCTIONS

(4) Vibration suppression control manual mode

POINT
<ul style="list-style-type: none"> ● When load-side vibration does not show up in servo motor-side vibration, the setting of the servo motor-side vibration frequency does not produce an effect. ● When the anti-resonance frequency and resonance frequency can be confirmed using the machine analyzer or external equipment, do not set the same value but set different values to improve the vibration suppression performance. ● The setting range of [Pr. PB19], [Pr. PB20], [Pr. PB52], and [Pr. PB53] varies, depending on the value in [Pr. PB07]. If a value out of the range is set, the vibration suppression control will be disabled.

Measure work-side vibration and device shake with the machine analyzer or external measuring instrument, and set the following parameters to adjust vibration suppression control manually.

Setting item	Vibration suppression control 1	Vibration suppression control 2
Vibration suppression control - Vibration frequency	[Pr. PB19]	[Pr. PB52]
Vibration suppression control - Resonance frequency	[Pr. PB20]	[Pr. PB53]
Vibration suppression control - Vibration frequency damping	[Pr. PB21]	[Pr. PB54]
Vibration suppression control - Resonance frequency damping	[Pr. PB22]	[Pr. PB55]

Step 1 Select "Manual setting (_ _ 2)" of "Vibration suppression control 1 tuning mode selection" or "Manual setting (_ _ 2 _)" of "Vibration suppression control 2 tuning mode selection" in [Pr. PB02].

Step 2 Set "Vibration suppression control - Vibration frequency" and "Vibration suppression control - Resonance frequency" as follows.

However, the value of [Pr. PB07 Model loop gain], vibration frequency, and resonance frequency have the following usable range and recommended range.

Vibration suppression control	Usable range	Recommended setting range
Vibration suppression control 1	$[Pr. PB19] > 1/2\pi \times (0.9 \times [Pr. PB07])$ $[Pr. PB20] > 1/2\pi \times (0.9 \times [Pr. PB07])$	$[Pr. PB19] > 1/2\pi \times (1.5 \times [Pr. PB07])$ $[Pr. PB20] > 1/2\pi \times (1.5 \times [Pr. PB07])$
Vibration suppression control 2	When $[Pr. PB19] < [Pr. PB52]$, $[Pr. PB52] > (5.0 + 0.1 \times [Pr. PB07])$ $[Pr. PB53] > (5.0 + 0.1 \times [Pr. PB07])$ $1.1 < [Pr. PB52]/[Pr. PB19] < 5.5$ $[Pr. PB07] < 2\pi (0.3 \times [Pr. PB19] + 1/8 \times [Pr. PB52])$	When $[Pr. PB19] < [Pr. PB52]$, $[Pr. PB52], [Pr. PB53] > 6.25 \text{ Hz}$ $1.1 < [Pr. PB52]/[Pr. PB19] < 4$ $[Pr. PB07] < 1/3 \times (4 \times [Pr. PB19] + 2 \times [Pr. PB52])$

7. SPECIAL ADJUSTMENT FUNCTIONS

- (a) When a vibration peak can be confirmed with machine analyzer using setup software (MR Configurator2™), or external equipment.

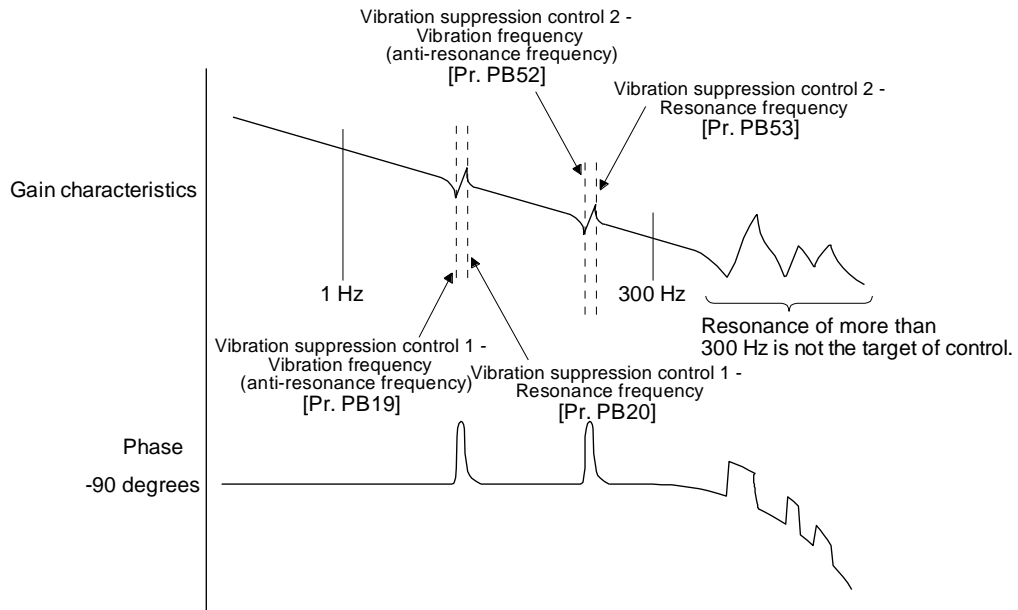

- (b) When vibration can be confirmed using monitor signal or external sensor

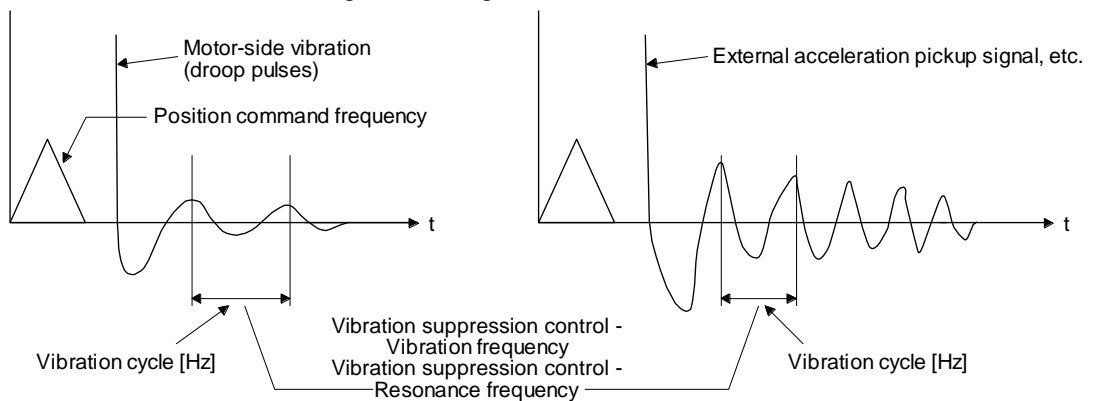

Set the same value.

- Step 3 Fine-adjust "Vibration suppression control - Vibration frequency damping" and "Vibration suppression control - Resonance frequency damping".

7. SPECIAL ADJUSTMENT FUNCTIONS

7.1.6 Command notch filter

POINT
●By using the advanced vibration suppression control II and the command notch filter, the load-side vibration of three frequencies can be suppressed.
●The frequency range of machine vibration, which can be supported by the command notch filter, is between 4.5 Hz and 2250 Hz. Set a frequency close to the machine vibration frequency and within the range.
●When [Pr. PB45 Command notch filter] is changed during the positioning operation, the changed setting is not reflected. The setting is reflected approximately 150 ms after the servo motor stops (after servo-lock).

(1) Function

Command notch filter has a function that lowers the gain of the specified frequency contained in a position command. By lowering the gain, load-side vibration, such as work-side vibration and base shake, can be suppressed. Which frequency to lower the gain and how deep to lower the gain can be set.

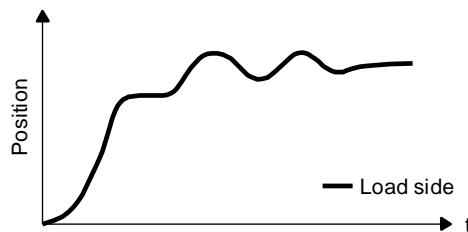

Command notch filter: disabled

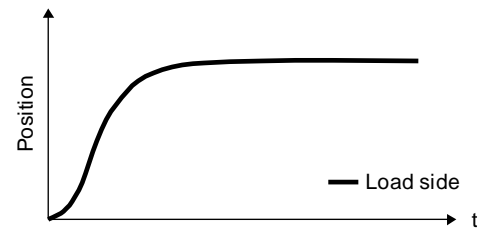

Command notch filter: enabled

7. SPECIAL ADJUSTMENT FUNCTIONS

(2) Parameter

Set [Pr. PB45 Command notch filter] as shown below. For the command notch filter setting frequency, set the closest value to the vibration frequency [Hz] at the load side.

[Pr. PB45]

0			
---	--	--	--

Notch depth

Setting value	Depth [dB]
0	-40.0
1	-24.1
2	-18.1
3	-14.5
4	-12.0
5	-10.1
6	-8.5
7	-7.2
8	-6.0
9	-5.0
A	-4.1
B	-3.3
C	-2.5
D	-1.8
E	-1.2
F	-0.6

Command notch filter setting frequency

Setting value	Frequency [Hz]
00	Disabled
01	2250
02	1125
03	750
04	562
05	450
06	375
07	321
08	281
09	250
0A	225
0B	204
0C	187
0D	173
0E	160
0F	150
10	140
11	132
12	125
13	118
14	112
15	107
16	102
17	97
18	93
19	90
1A	86
1B	83
1C	80
1D	77
1E	75
1F	72

Setting value	Frequency [Hz]
20	70
21	66
22	62
23	59
24	56
25	53
26	51
27	48
28	46
29	45
2A	43
2B	41
2C	40
2D	38
2E	37
2F	36
30	35.2
31	33.1
32	31.3
33	29.6
34	28.1
35	26.8
36	25.6
37	24.5
38	23.4
39	22.5
3A	21.6
3B	20.8
3C	20.1
3D	19.4
3E	18.8
3F	18.2

Setting value	Frequency [Hz]
40	17.6
41	16.5
42	15.6
43	14.8
44	14.1
45	13.4
46	12.8
47	12.2
48	11.7
49	11.3
4A	10.8
4B	10.4
4C	10.0
4D	9.7
4E	9.4
4F	9.1
50	8.8
51	8.3
52	7.8
53	7.4
54	7.0
55	6.7
56	6.4
57	6.1
58	5.9
59	5.6
5A	5.4
5B	5.2
5C	5.0
5D	4.9
5E	4.7
5F	4.5

7.2 Gain switching function

You can switch gains with the function. You can switch gains during rotation and during stop, and can use an input device to switch gains during operation.

7.2.1 Applications

The following shows when you use the function.

- (1) You want to increase the gains during servo-lock but decrease the gains to reduce noise during rotation.
- (2) You want to increase the gains during settling to shorten the stop settling time.
- (3) You want to change the gains using an input device to ensure stability of the servo system since the load to motor inertia ratio varies greatly during a stop (e.g. a large load is mounted on a carrier).

7. SPECIAL ADJUSTMENT FUNCTIONS

7.2.2 Function block diagram

The control gains, load to motor inertia ratio, and vibration suppression control settings are changed according to the conditions selected by [Pr. PB26 Gain switching function] and [Pr. PB27 Gain switching condition].

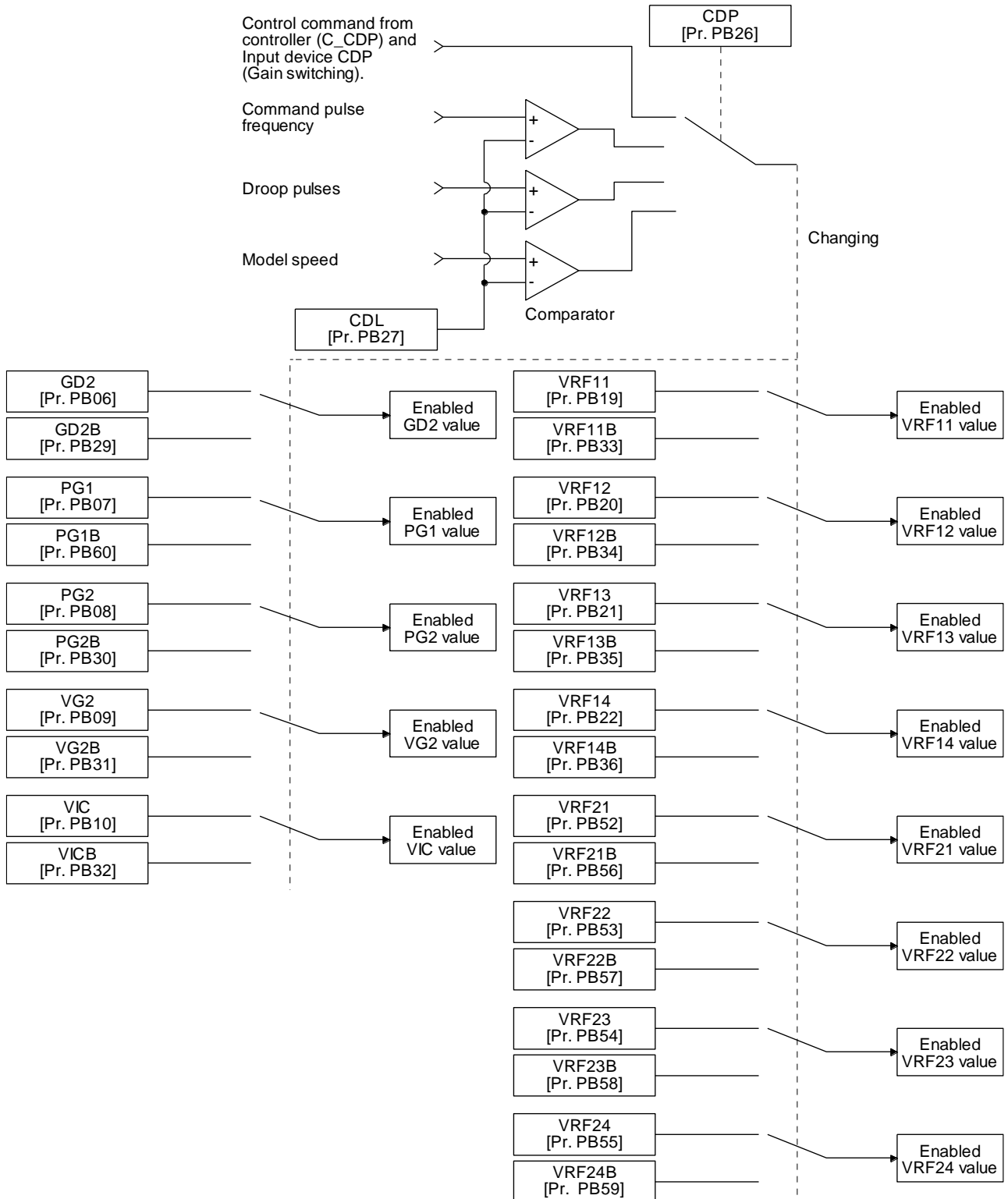

7. SPECIAL ADJUSTMENT FUNCTIONS

7.2.3 Parameter

When using the gain switching function, always select "Manual mode (_ _ _ 3)" of "Gain adjustment mode selection" in [Pr. PA08 Auto tuning mode]. The gain switching function cannot be used in the auto tuning mode.

(1) Parameter for setting gain switching condition

Parameter	Symbol	Name	Unit	Description
PB26	CDP	Gain switching function		Select a switching condition.
PB27	CDL	Gain switching condition	[kpulse/s] /[pulse] /[r/min]	Set a switching condition values.
PB28	CDT	Gain switching time constant	[ms]	Set the filter time constant for a gain change at switching.

(a) [Pr. PB26 Gain switching function]

Used to set the gain switching condition. Select the switching condition in the first to third digits.

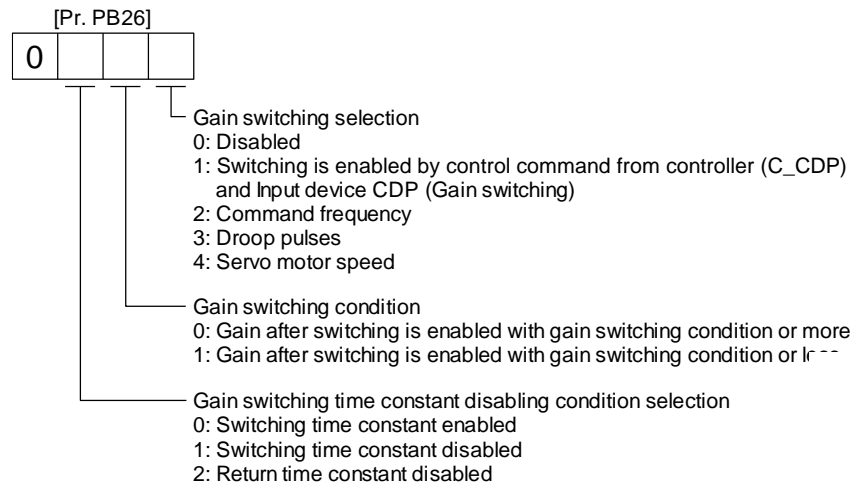

(b) [Pr. PB27 Gain switching condition]

Set a level to switch gains with [Pr. PB27] after you select "Command frequency", "Droop pulses", or "Servo motor speed" with the gain switching selection in [Pr. PB26 Gain switching function].

The setting unit is as follows.

Gain switching condition	Unit
Command frequency	[kpulse/s]
Droop pulses	[pulse]
Servo motor speed	[r/min]

(c) [Pr. PB28 Gain switching time constant]

You can set the primary delay filter to each gain at gain switching. This parameter is used to suppress shock given to the machine if the gain difference is large at gain switching, for example.

7. SPECIAL ADJUSTMENT FUNCTIONS

(2) Switchable gain parameter

Loop gain	Before switching			After switching		
	Parameter	Symbol	Name	Parameter	Symbol	Name
Load to motor inertia ratio	PB06	GD2	Load to motor inertia ratio	PB29	GD2B	Load to motor inertia ratio after gain switching
Model loop gain	PB07	PG1	Model loop gain	PB60	PG1B	Model loop gain after gain switching
Position loop gain	PB08	PG2	Position loop gain	PB30	PG2B	Position loop gain after gain switching
Speed loop gain	PB09	VG2	Speed loop gain	PB31	VG2B	Speed loop gain after gain switching
Speed integral compensation	PB10	VIC	Speed integral compensation	PB32	VICB	Speed integral compensation after gain switching
Vibration suppression control 1 - Vibration frequency	PB19	VRF11	Vibration suppression control 1 - Vibration frequency	PB33	VRF11B	Vibration suppression control 1 - Vibration frequency after gain switching
Vibration suppression control 1 - Resonance frequency	PB20	VRF12	Vibration suppression control 1 - Resonance frequency	PB34	VRF12B	Vibration suppression control 1 - Resonance frequency after gain switching
Vibration suppression control 1 - Vibration frequency damping	PB21	VRF13	Vibration suppression control 1 - Vibration frequency damping	PB35	VRF13B	Vibration suppression control 1 - Vibration frequency damping after gain switching
Vibration suppression control 1 - Resonance frequency damping	PB22	VRF14	Vibration suppression control 1 - Resonance frequency damping	PB36	VRF14B	Vibration suppression control 1 - Resonance frequency damping after gain switching
Vibration suppression control 2 - Vibration frequency	PB52	VRF21	Vibration suppression control 2 - Vibration frequency	PB56	VRF21B	Vibration suppression control 2 - Vibration frequency after gain switching
Vibration suppression control 2 - Resonance frequency	PB53	VRF22	Vibration suppression control 2 - Resonance frequency	PB57	VRF22B	Vibration suppression control 2 - Resonance frequency after gain switching
Vibration suppression control 2 - Vibration frequency damping	PB54	VRF23	Vibration suppression control 2 - Vibration frequency damping	PB58	VRF23B	Vibration suppression control 2 - Vibration frequency damping after gain switching
Vibration suppression control 2 - Resonance frequency damping	PB55	VRF24	Vibration suppression control 2 - Resonance frequency damping	PB59	VRF24B	Vibration suppression control 2 - Resonance frequency damping after gain switching

(a) [Pr. PB06] to [Pr. PB10]

These parameters are the same as in ordinary manual adjustment. Gain switching allows the values of load to motor inertia ratio, position loop gain, speed loop gain, and speed integral compensation to be switched.

(b) [Pr. PB19] to [Pr. PB22]/[Pr. PB52] to [Pr. PB55]

These parameters are the same as in ordinary manual adjustment. Executing gain switching while the servo motor stops, You can change vibration frequency, resonance frequency, vibration frequency damping, and resonance frequency damping.

7. SPECIAL ADJUSTMENT FUNCTIONS

- (c) [Pr. PB29 Load to motor inertia ratio after gain switching]
Set the load to motor inertia ratio after gain switching. If the load to motor inertia ratio does not change, set it to the same value as [Pr. PB06 Load to motor inertia ratio].
- (d) [Pr. PB30 Position loop gain after gain switching], [Pr. PB31 Speed loop gain after gain switching], and [Pr. PB32 Speed integral compensation after gain switching]
Set the values of after switching position loop gain, speed loop gain and speed integral compensation.
- (e) Vibration suppression control after gain switching ([Pr. PB33] to [Pr. PB36]/[Pr. PB56] to [Pr. PB59]), and [Pr. PB60 Model loop gain after gain switching]
The gain switching vibration suppression control and model loop gain are used only with control command from the PC or PLC...etc.
You can switch the vibration frequency, resonance frequency, vibration frequency damping, resonance frequency damping, and model loop gain of the vibration suppression control 1 and vibration suppression control 2.

7. SPECIAL ADJUSTMENT FUNCTIONS

7.2.4 Gain switching procedure

This operation will be described by way of setting examples.

(1) When you choose switching by control command from the PC or PLC...etc

(a) Setting

Parameter	Symbol	Name	Setting value	Unit
PB06	GD2	Load to motor inertia ratio/load to motor mass ratio	4.00	[Multiplier]
PB07	PG1	Model loop gain	100	[rad/s]
PB08	PG2	Position loop gain	120	[rad/s]
PB09	VG2	Speed loop gain	3000	[rad/s]
PB10	VIC	Speed integral compensation	20	[ms]
PB19	VRF11	Vibration suppression control 1 - Vibration frequency	50	[Hz]
PB20	VRF12	Vibration suppression control 1 - Resonance frequency	50	[Hz]
PB21	VRF13	Vibration suppression control 1 - Vibration frequency damping	0.20	
PB22	VRF14	Vibration suppression control 1 - Resonance frequency damping	0.20	
PB52	VRF21	Vibration suppression control 2 - Vibration frequency	20	[Hz]
PB53	VRF22	Vibration suppression control 2 - Resonance frequency	20	[Hz]
PB54	VRF23	Vibration suppression control 2 - Vibration frequency damping	0.10	
PB55	VRF24	Vibration suppression control 2 - Resonance frequency damping	0.10	
PB29	GD2B	Load to motor inertia ratio/load to motor mass ratio after gain switching	10.00	[Multiplier]
PB60	PG1B	Model loop gain after gain switching	50	[rad/s]
PB30	PG2B	Position loop gain after gain switching	84	[rad/s]
PB31	VG2B	Speed loop gain after gain switching	4000	[rad/s]
PB32	VICB	Speed integral compensation after gain switching	50	[ms]
PB26	CDP	Gain switching function	0001 (Switch by control command from the controller (C_CDP) and Input device CDP (Gain switching).)	
PB28	CDT	Gain switching time constant	100	[ms]
PB33	VRF11B	Vibration suppression control 1 - Vibration frequency after gain switching	60	[Hz]
PB34	VRF12B	Vibration suppression control 1 - Resonance frequency after gain switching	60	[Hz]
PB35	VRF13B	Vibration suppression control 1 - Vibration frequency damping after gain switching	0.15	
PB36	VRF14B	Vibration suppression control 1 - Resonance frequency damping after gain switching	0.15	
PB56	VRF21B	Vibration suppression control 2 - Vibration frequency after gain switching	30	[Hz]
PB57	VRF22B	Vibration suppression control 2 - Resonance frequency after gain switching	30	[Hz]
PB58	VRF23B	Vibration suppression control 2 - Vibration frequency damping after gain switching	0.05	
PB59	VRF24B	Vibration suppression control 2 - Resonance frequency damping after gain switching	0.05	

7. SPECIAL ADJUSTMENT FUNCTIONS

(b) Switching timing chart

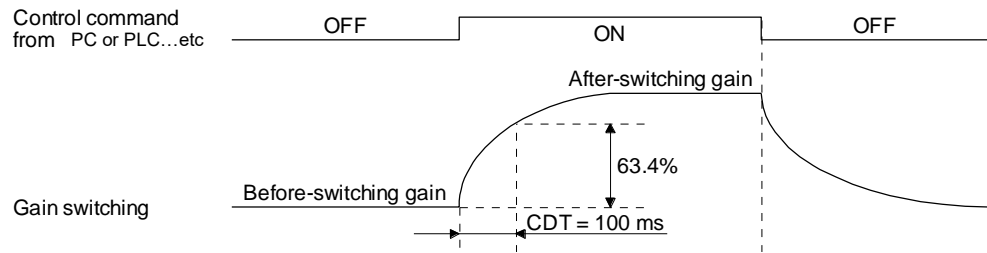

Model loop gain	100	→	50	→	100
Load to motor inertia ratio/load to motor mass ratio	4.00	→	10.00	→	4.00
Position loop gain	120	→	84	→	120
Speed loop gain	3000	→	4000	→	3000
Speed integral compensation	20	→	50	→	20
Vibration suppression control 1 - Vibration frequency	50	→	60	→	50
Vibration suppression control 1 - Resonance frequency	50	→	60	→	50
Vibration suppression control 1 - Vibration frequency damping	0.20	→	0.15	→	0.20
Vibration suppression control 1 - Resonance frequency damping	0.20	→	0.15	→	0.20
Vibration suppression control 2 - Vibration frequency	20	→	30	→	20
Vibration suppression control 2 - Resonance frequency	20	→	30	→	20
Vibration suppression control 2 - Vibration frequency damping	0.10	→	0.05	→	0.10
Vibration suppression control 2 - Resonance frequency damping	0.10	→	0.05	→	0.10

(2) When you choose switching by droop pulses

The vibration suppression control after gain switching and model loop gain after gain switching cannot be used.

(a) Setting

Parameter	Symbol	Name	Setting value	Unit
PB06	GD2	Load to motor inertia ratio/load to motor mass ratio	4.00	[Multiplier]
PB08	PG2	Position loop gain	120	[rad/s]
PB09	VG2	Speed loop gain	3000	[rad/s]
PB10	VIC	Speed integral compensation	20	[ms]
PB29	GD2B	Load to motor inertia ratio/load to motor mass ratio after gain switching	10.00	[Multiplier]
PB30	PG2B	Position loop gain after gain switching	84	[rad/s]
PB31	VG2B	Speed loop gain after gain switching	4000	[rad/s]
PB32	VICB	Speed integral compensation after gain switching	50	[ms]
PB26	CDP	Gain switching selection	0003 (switching by droop pulses)	
PB27	CDL	Gain switching condition	50	[pulse]
PB28	CDT	Gain switching time constant	100	[ms]

7. SPECIAL ADJUSTMENT FUNCTIONS

(b) Switching timing chart

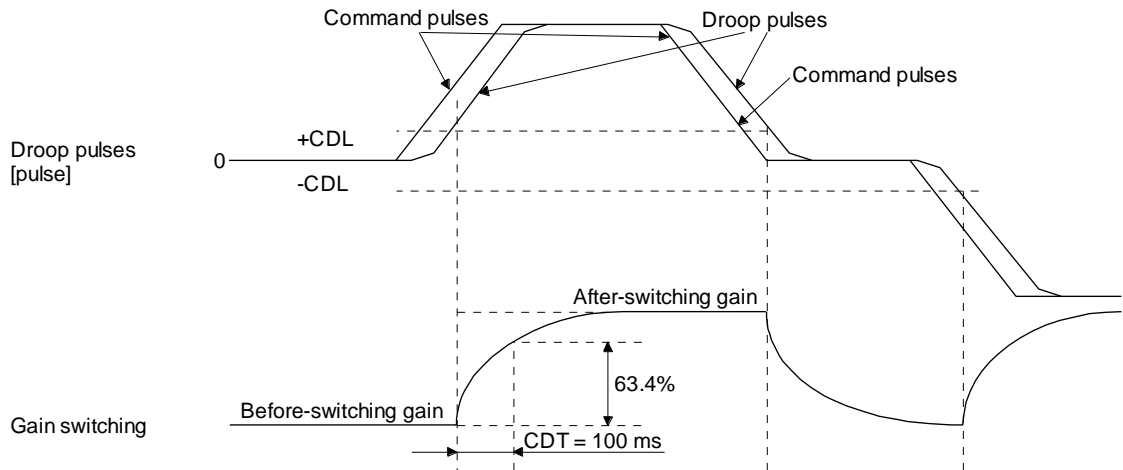

Load to motor inertia ratio	4.00	→	10.00	→	4.00	→	10.00
Position loop gain	120	→	84	→	120	→	84
Speed loop gain	3000	→	4000	→	3000	→	4000
Speed integral compensation	20	→	50	→	20	→	50

3) When the gain switching time constant is disabled

(a) Switching time constant disabled was selected.

The gain switching time constant is disabled. The time constant is enabled at gain return.

The following example shows for [Pr. PB26 (CDP)] = 0103, [Pr. PB27 (CDL)] = 100 [pulse], and [Pr. PB28 (CDT)] = 100 [ms].

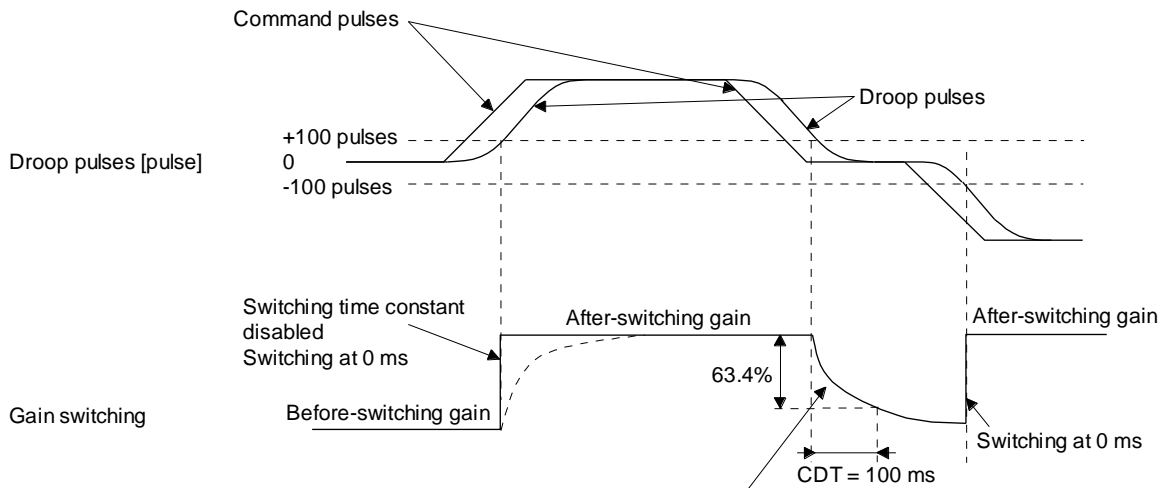

Switching at [Pr. PB28 (CDT)] = 100 [ms] only when gain switching off (when returning)

7. SPECIAL ADJUSTMENT FUNCTIONS

(b) Return time constant disabled was selected.

The gain switching time constant is enabled. The time constant is disabled at gain return.

The following example shows for [Pr. PB26 (CDP)] = 0201, [Pr. PB27 (CDL)] = 0, and [Pr. PB28 (CDT)] = 100 [ms].

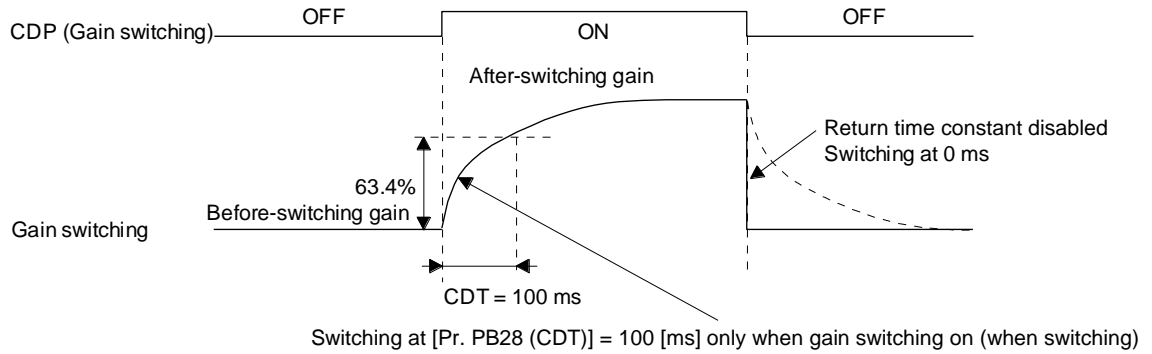

7. SPECIAL ADJUSTMENT FUNCTIONS

7.3 Tough drive function

POINT
●Set enable/disable of the tough drive function with [Pr. PA20 Tough drive setting]. (Refer to section 5.2.1.)

This function makes the equipment continue operating even under the condition that an alarm occurs. The tough drive functions are the vibration tough drive and the instantaneous power failure tough drive.

7.3.1 Vibration tough drive function

This function prevents vibration by resetting a filter instantaneously when machine resonance occurs due to varied vibration frequency caused by machine aging.

To reset the machine resonance suppression filters with the function, [Pr. PB13 Machine resonance suppression filter 1] and [Pr. PB15 Machine resonance suppression filter 2] should be set in advance. Set [Pr. PB13] and [Pr. PB15] as follows.

- (1) One-touch tuning execution (section 6.1)
- (2) Manual setting (section 4.2.2)

The vibration tough drive function operates when a detected machine resonance frequency is within $\pm 30\%$ for a value set in [Pr. PB13 Machine resonance suppression filter 1] or [Pr. PB15 Machine resonance suppression filter 2].

To set a detection level of the function, set sensitivity in [Pr. PF23 Vibration tough drive - Oscillation detection level].

POINT
●Resetting [Pr. PB13] and [Pr. PB15] by the vibration tough drive function is performed constantly. However, the number of write times to the EEPROM is limited to once per hour.
●The vibration tough drive function does not reset [Pr. PB46 Machine resonance suppression filter 3], [Pr. PB48 Machine resonance suppression filter 4], and [Pr. PB50 Machine resonance suppression filter 5].
●The vibration tough drive function does not detect a vibration of 100 Hz or less.

7. SPECIAL ADJUSTMENT FUNCTIONS

The following shows the function block diagram of the vibration tough drive function.

The function detects machine resonance frequency and compare it with [Pr. PB13] and [Pr. PB15], and reset a machine resonance frequency of a parameter whose set value is closer.

Filter	Setting parameter	Precaution	Parameter that is reset with vibration tough drive function
Machine resonance suppression filter 1	PB01/PB13/PB14	The filter can be set automatically with "Filter tuning mode selection" in [Pr. PB01].	PB13
Machine resonance suppression filter 2	PB15/PB16		PB15
Machine resonance suppression filter 3	PB46/PB47		
Machine resonance suppression filter 4	PB48/PB49	Enabling the machine resonance suppression filter 4 disables the shaft resonance suppression filter. Using the shaft resonance suppression filter is recommended because it is adjusted properly depending on the usage situation. The shaft resonance suppression filter is enabled for the initial setting.	
Machine resonance suppression filter 5	PB50/PB51	Enabling the robust filter disables the machine resonance suppression filter 5. The robust filter is disabled for the initial setting.	

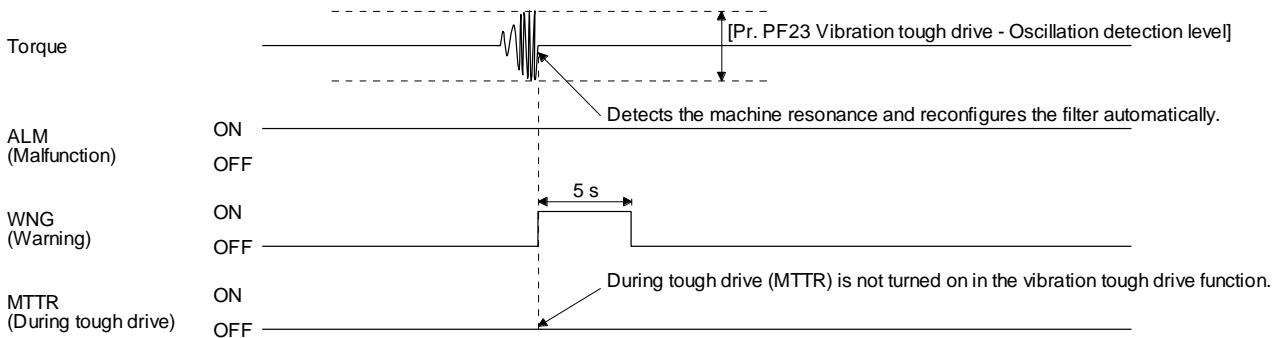
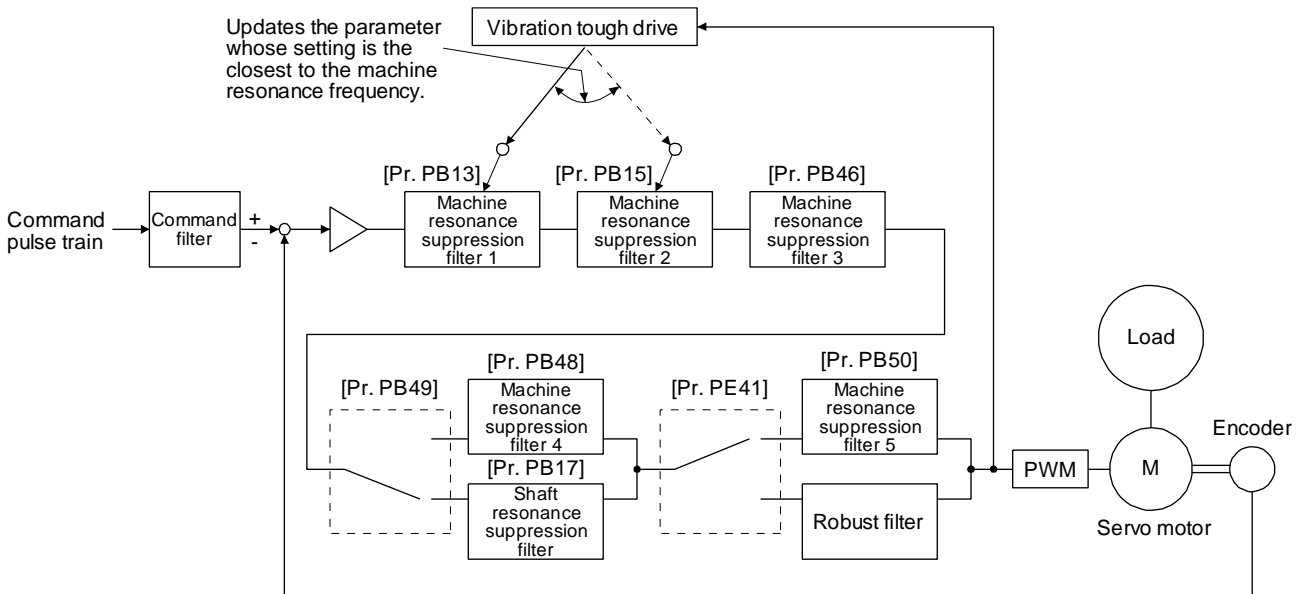

7. SPECIAL ADJUSTMENT FUNCTIONS

7.3.2 Instantaneous power failure tough drive function

The instantaneous power failure tough drive function avoids [AL. 10 Undervoltage] even when an instantaneous power failure occurs during operation. When the instantaneous power failure tough drive activates, the function will increase the tolerance against instantaneous power failure using the electrical energy charged in the capacitor in the driver and will change an alarm level of [AL. 10 Undervoltage] simultaneously. The [AL. 10.1 Voltage drop in the control circuit power] detection time for the control circuit power supply can be changed by [Pr. PF25 SEMI-F47 function - Instantaneous power failure detection time]. In addition, [AL. 10.2 Voltage drop in the main circuit power] detection level for the bus voltage is changed automatically.

POINT
<ul style="list-style-type: none">● MBR (Electromagnetic brake interlock) will not turn off during the instantaneous power failure tough drive.● When selecting "Enabled (_ _ _ 1)" for "Torque limit function selection at instantaneous power failure" in [Pr. PA26], if an instantaneous power failure occurs during operation, you can save electric energy charged in the capacitor in the driver by limiting torque at acceleration. You can also delay the time until the occurrence of [AL. 10.2 Voltage drop in the main circuit power]. Doing this will enable you to set a longer time in [Pr. PF25 SEMI-F47 function - Instantaneous power failure detection time].● When the load of instantaneous power failure is large, [AL. 10.2] caused by the bus voltage drop may occur regardless of the set value of [Pr. PF25 SEMI-F47 function - Instantaneous power failure detection time].● To comply with SEMI-F47 standard, it is unnecessary to change the initial value (200 ms) in [Pr. PF25 SEMI-F47 function - Instantaneous power failure detection time]. When the instantaneous power failure time exceeds 200 ms, and the instantaneous power failure voltage is less than 70% of the rated input voltage, the power may be normally turned off even if a value larger than 200 ms is set in the parameter.

7. SPECIAL ADJUSTMENT FUNCTIONS

- (1) Instantaneous power failure time of the control circuit power supply > [Pr. PF25 SEMI-F47 function - Instantaneous power failure detection time]

The alarm occurs when the instantaneous power failure time of the control circuit power supply exceeds [Pr. PF25 SEMI-F47 function - Instantaneous power failure detection time].

MTTR (During tough drive) turns on after detecting the instantaneous power failure.

MBR (Electromagnetic brake interlock) turns off when the alarm occurs.

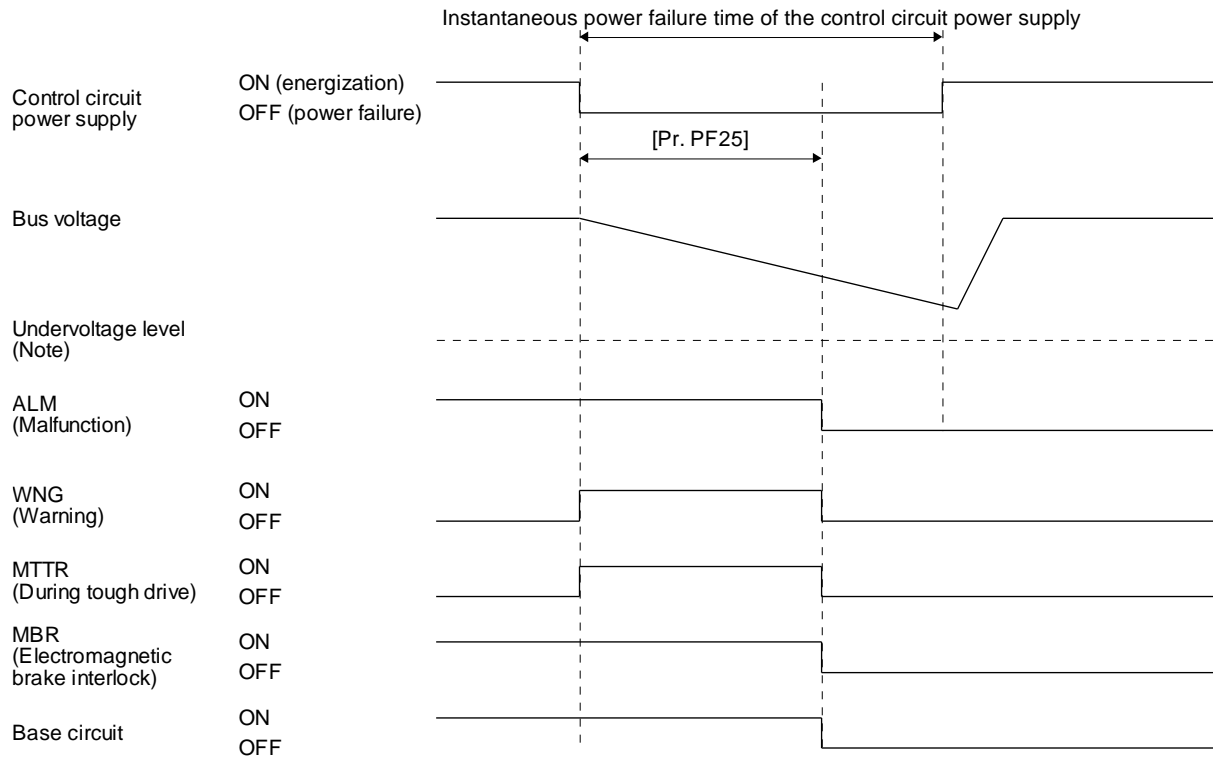

Note. Refer to table 7.1 for the undervoltage level.

7. SPECIAL ADJUSTMENT FUNCTIONS

- (2) Instantaneous power failure time of the control circuit power supply < [Pr. PF25 SEMI-F47 function - Instantaneous power failure detection time]

Operation status differs depending on how bus voltage decrease.

- (a) When the bus voltage decrease lower than undervoltage level within the instantaneous power failure time of the control circuit power supply

[AL. 10 Undervoltage] occurs when the bus voltage decrease lower than undervoltage level regardless of the enabled instantaneous power failure tough drive.

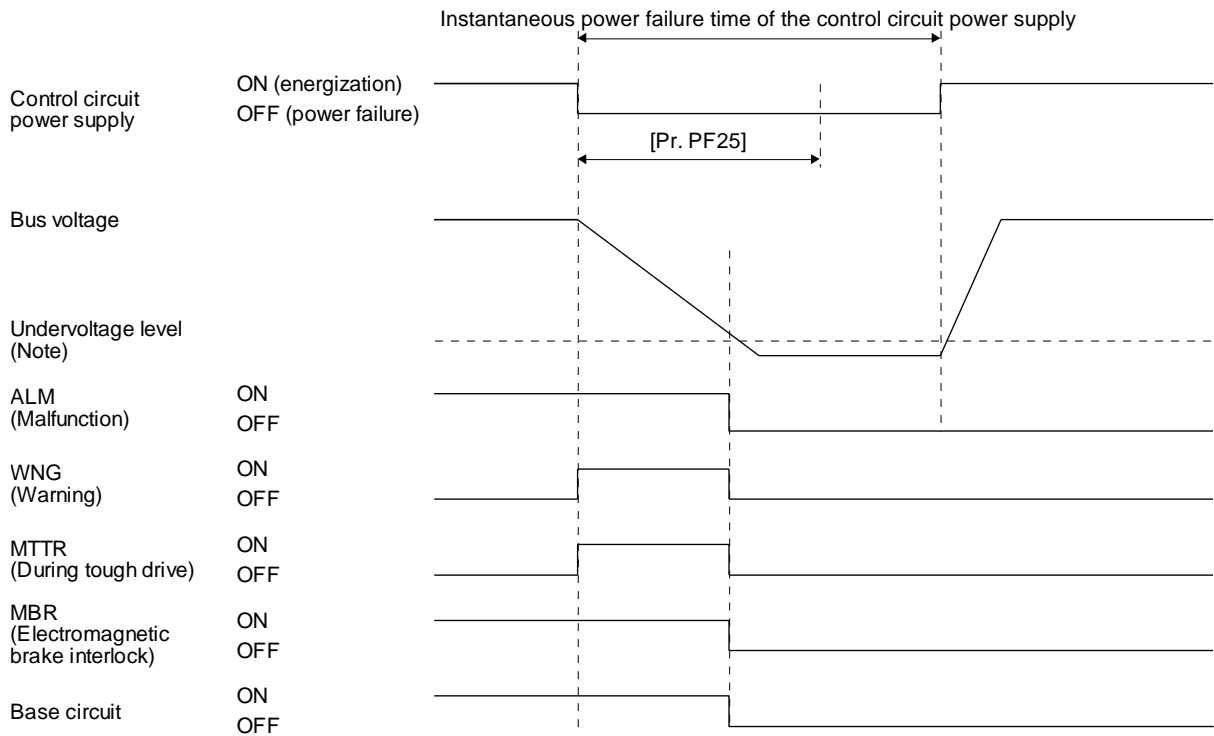

Note. Refer to table 7.1 for the undervoltage level.

7. SPECIAL ADJUSTMENT FUNCTIONS

- (b) When the bus voltage does not decrease lower than 158 V DC within the instantaneous power failure time of the control circuit power supply
The operation continues without alarming.

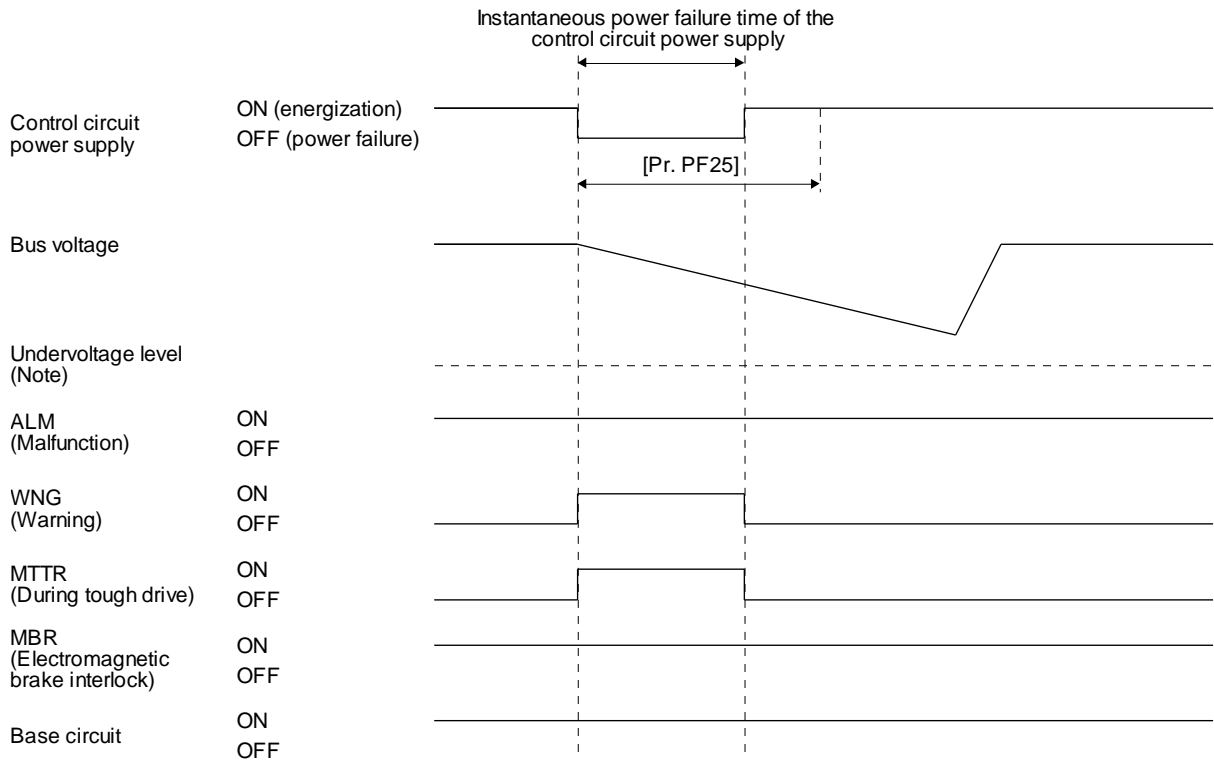

Note. Refer to table 7.1 for the undervoltage level.

7. SPECIAL ADJUSTMENT FUNCTIONS

7.4 Compliance with SEMI-F47 standard

POINT
<ul style="list-style-type: none"> ● The control circuit power supply of the the driver can comply with SEMI-F47 standard. However, a back-up capacitor may be necessary for instantaneous power failure in the main circuit power supply depending on the power supply impedance and operating situation. ● Use a 3-phase for the input power supply of the driver. Using a 1-phase 100 V AC/200 V AC for the input power supply will not comply with SEMI-F47 standard. ● Be sure to perform actual machine tests and detail checks for power supply instantaneous power failure of SEMI-F47 standard with your equipment.

The following explains the compliance with "SEMI-F47 semiconductor process equipment voltage sag immunity test".

This function enables to avoid triggering [AL. 10 Undervoltage] using the electrical energy charged in the capacitor in case that an instantaneous power failure occurs during operation.

(1) Parameter setting

Setting [Pr. PA20] and [Pr. PF25] as follows will enable SEMI-F47.

Parameter	Setting value	Description
PA20	_ 1 _ _	SEMI-F47 selection
PF25	200	Set the time [ms] of the [AL. 10.1 Voltage drop in the control circuit power] occurrence.

Enabling SEMI-F47 will change operation as follows.

- (a) The voltage will drop in the control circuit power at "Rated voltage × 50% or less". After 200 ms, [AL. 10.1 Voltage drop in the control circuit power] will occur.
- (b) [AL. 10.2 Voltage drop in the main circuit power] will occur when bus voltage is as follows.

Table 7.1 Voltages which trigger [AL. 10.2 Voltage drop in the main circuit power]

Bus voltage which triggers alarm
158 V DC

- (c) MBR (Electromagnetic brake interlock) will turn off when [AL. 10.1 Voltage drop in the control circuit power] occurs.

7. SPECIAL ADJUSTMENT FUNCTIONS

(2) Requirements and recommended conditions of SEMI-F47 standard

Table 7.1 shows the permissible time of instantaneous power failure for instantaneous power failure of SEMI-F47 standard.

Table 7.2 Requirements conditions of SEMI-F47 standard

Instantaneous power failure voltage	Permissible time of instantaneous power failure [s]
Rated voltage × 80%	1
Rated voltage × 70%	0.5
Rated voltage × 50%	0.2

(3) Calculation of tolerance against instantaneous power failure

Table 7.3 shows tolerance against instantaneous power failure when instantaneous power failure voltage is "rated voltage × 50%" and instantaneous power failure time is 200 ms.

Table 7.3 Tolerance against instantaneous power failure (instantaneous power failure voltage = rated voltage × 50%, instantaneous power failure time = 200 ms)

driver	Instantaneous maximum output [W]	Tolerance against instantaneous power failure [W] (voltage drop between lines)
LECSND2-T5	350	250
LECSND2-T7	700	420
LECSND2-T8	1400	630
LECSND2-T9	2625	1150

Instantaneous maximum output means power which driver can output in maximum torque at rated speed. You can examine margins to compare the values of following conditions and instantaneous maximum output.

Even if driving at maximum torque with low speed in actual operation, the motor will not drive with the maximum output. This can be handled as a margin.

The following shows the conditions of tolerance against instantaneous power failure.

(a) Delta connection

For the 3-phase (L1/L2/L3) delta connection, an instantaneous power failure occurs in the voltage between a pair of lines (e.g. between L1 and L2) among voltages between three pairs of lines (between L1 and L2, L2 and L3, or L3 and L1).

(b) Star connection

For the 3-phase (L1/L2/L3/neutral point N) star connection, an instantaneous power failure occurs in the voltage between a pair of lines (e.g. between L1 and N) among voltages at six locations, between three pairs of lines (between L1 and L2, L2 and L3, or L3 and L1) and between one of the lines and the neutral point (between L1 and N, L2 and N, or L3 and N).

7. SPECIAL ADJUSTMENT FUNCTIONS

7.5 Model adaptive control disabled

POINT	<ul style="list-style-type: none"> ● Change the parameters while the servo motor stops. ● When setting auto tuning response ([Pr. PA09]), change the setting value one by one to adjust it while checking operation status of the servo motor.
-------	--

(1) Summary

The driver has a model adaptive control. The driver has a virtual motor model and drives the servo motor following the output of the motor model in the model adaptive control. At model adaptive control disabled, the driver drives the motor with PID control without using the model adaptive control.

The following shows the available parameters at model adaptive control disabled.

Parameter	Symbol	Name
PB08	PG2	Position loop gain
PB09	VG2	Speed loop gain
PB10	VIC	Speed integral compensation

(2) Parameter setting

Set [Pr. PB25] to " _ _ _ 2".

(3) Restrictions

The following functions are not available at model adaptive control disabled.

Function	Explanation
Forced stop deceleration function ([Pr. PA04])	Disabling the model adaptive control while the forced stop deceleration function is enabled, [AL. 37] will occur. The forced stop deceleration function is enabled at factory setting. Set [Pr. PA04] to "0 _ _ _" (Forced stop deceleration function disabled).
Vibration suppression control 1 ([Pr. PB02]/[Pr. PB19]/[Pr. PB20]) Vibration suppression control 2 ([Pr. PB02]/[Pr. PB52]/[Pr. PB53])	The vibration suppression control uses the model adaptive control. Disabling the model adaptive control will also disable the vibration suppression control.
Overshoot amount compensation ([Pr. PB12])	The overshoot amount compensation uses data used by the model adaptive control. Disabling the model adaptive control will also disable the overshoot amount compensation.
Super trace control ([Pr. PA22])	The super trace control uses the model adaptive control. Disabling the model adaptive control will also disable the super trace control.

7. SPECIAL ADJUSTMENT FUNCTIONS

7.6 Lost motion compensation function

POINT
<p>● The lost motion compensation function is enabled only in the position control mode.</p>

The lost motion compensation function corrects response delays (caused by a non-sensitive band due to friction, twist, expansion, and backlash) caused when the machine travel direction is reversed. This function contributes to improvement for protrusions that occur at a quadrant change and streaks that occur at a quadrant change during circular cutting.

This function is effective when a high follow-up performance is required such as drawing an arc with an X-Y table.

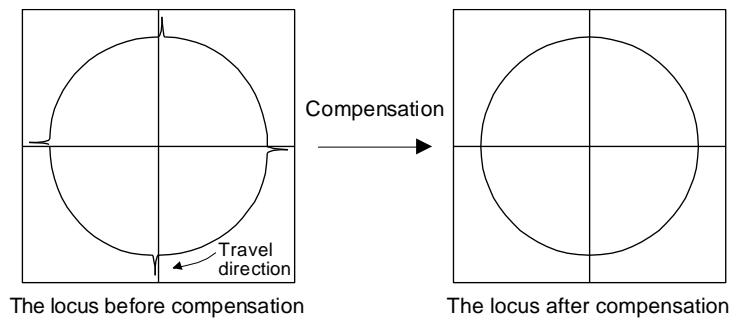

(1) Parameter setting

Setting [Pr. PE44] to [Pr. PE50] enables the lost motion compensation function.

(a) Lost motion compensation function selection ([Pr. PE48])

Select the lost motion compensation function.

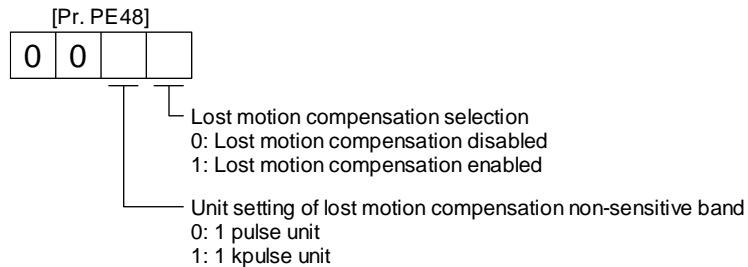

(b) Lost motion compensation ([Pr. PE44]/[Pr. PE45])

Set the same value for the lost motion compensation for each of when the forward rotation switches to the reverse rotation and when the reverse rotation switches to the forward rotation. When the heights of protrusions differ depending on the travel direction, set the different compensation for each travel direction. Set a value twice the usual friction torque and adjust the value while checking protrusions.

(c) Torque offset ([Pr. PE47])

For a vertical axis, unbalanced torque occurs due to the gravity. Although setting the torque offset is usually unnecessary, setting unbalanced torque of a machine as a torque offset cancels the unbalanced torque. The torque offset does not need to be set for a machine not generating unbalanced torque.

7. SPECIAL ADJUSTMENT FUNCTIONS

(d) Lost motion compensation timing ([Pr. PE49])

You can set the delay time of the lost motion compensation start timing with this parameter. When a protrusion occurs belatedly, set the lost motion compensation timing corresponding to the protrusion occurrence timing.

(e) Lost motion compensation non-sensitive band ([Pr. PE50])

When the travel direction reverses frequently around the zero speed, unnecessary lost motion compensation is triggered by the travel direction switching. By setting the lost motion compensation non-sensitive band, the speed is recognized as 0 when the fluctuation of the droop pulse is the setting value or less. This prevents unnecessary lost motion compensation.

When the value of this parameter is changed, the compensation timing is changed. Adjust the value of Lost motion compensation timing ([Pr. PE49]).

(f) Lost motion filter setting ([Pr. PE46])

Changing the value of this parameter is usually unnecessary. When a value other than 0.0 ms is set in this parameter, the high-pass filter output value of the set time constant is applied to the compensation and lost motion compensation continues.

(2) Adjustment procedure of the lost motion compensation function

(a) Measuring the load current

Measure the load currents during the forward direction feed and reverse direction feed with setup software (MR Configurator2™).

(b) Setting the lost motion compensation

Calculate the friction torque from the measurement result of (2) (a) in this section and set a value twice the friction torque in [Pr. PE44] and [Pr. PE45] as lost motion compensation.

$$\text{Friction torque [\%]} = \frac{|(\text{load current during feed in the forward rotation direction [\%]} - \text{load current during feed in the reverse rotation direction [\%]|}{2}$$

(c) Checking protrusions

Drive the servo motor and check that the protrusions are corrected.

7. SPECIAL ADJUSTMENT FUNCTIONS

(d) Adjusting the lost motion compensation

When protrusions still occur, the compensation is insufficient. Increase the lost motion compensation by approximately 0.5% until the protrusions are eliminated. When notches occur, the compensation is excessive. Decrease the lost motion compensation by approximately 0.5% until the notches are eliminated. Different values can be set as the compensation for each of when the forward rotation (CCW) switches to the reverse rotation (CW) and when the reverse rotation (CW) switches to the forward rotation (CCW).

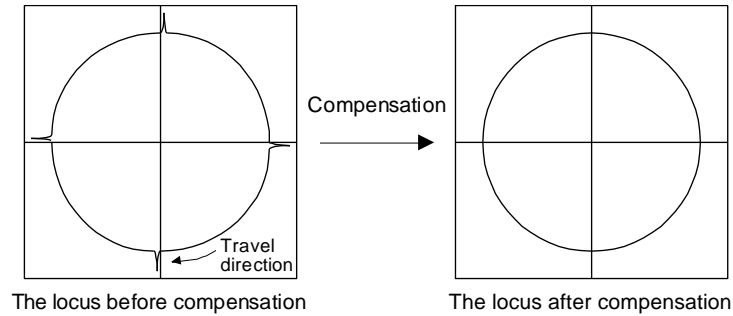

(e) Adjusting the lost motion compensation timing

When the machine has low rigidity, the speed loop gain is set lower than the standard setting value, or the servo motor is rotating at high speed, quadrant projections may occur behind the quadrant change points. In this case, you can suppress the quadrant projections by delaying the lost motion compensation timing with [Pr. PE49 Lost motion compensation timing]. Increase the setting value of [Pr. PE49] from 0 ms (initial value) by approximately 0.5 ms to adjust the compensation timing.

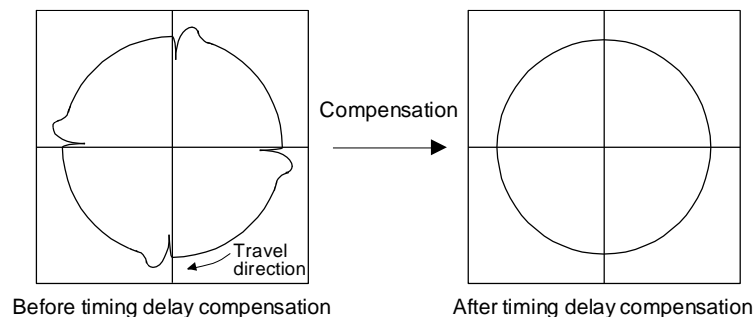

(f) Adjusting the lost motion compensation non-sensitive band

When the lost motion is compensated twice around a quadrant change point, set [Pr. PE50 Lost motion compensation non-sensitive band]. Increase the setting value so that the lost motion is not compensated twice. Setting [Pr. PE50] may change the compensation timing. Adjust the lost motion compensation timing of (2) (e) in this section.

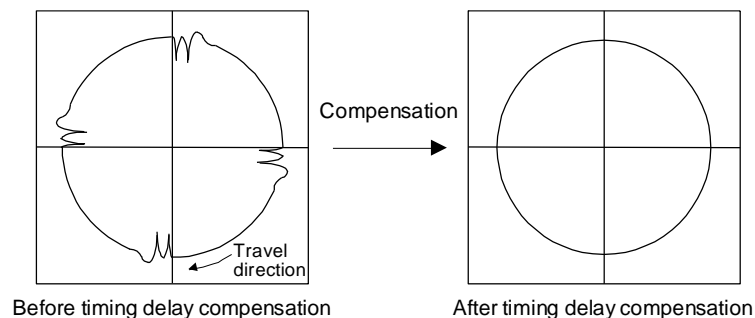

7. SPECIAL ADJUSTMENT FUNCTIONS

7.7 Super trace control

(1) Summary

In the normal position control, droop pulses are generated against the position control command from the PC or PLC...etc. Using the feed forward gain sets droop pulses at a constant speed to almost 0. However, droop pulses generated during acceleration/deceleration cannot be suppressed.

With the ideal model in the driver, the super trace control enables to set constant speed and uniform acceleration/deceleration droop pulses to almost 0 that cannot be coped with by the feed forward gain.

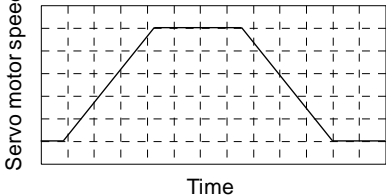
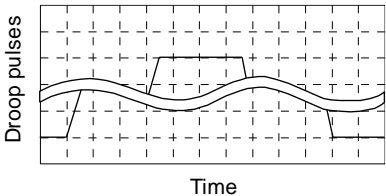
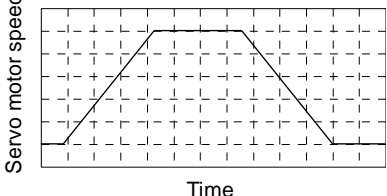
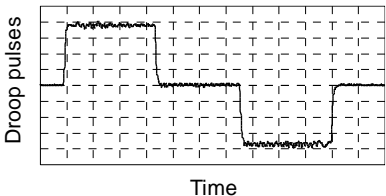
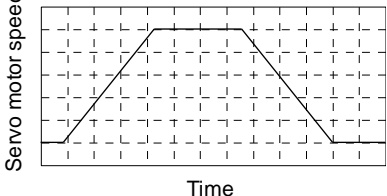
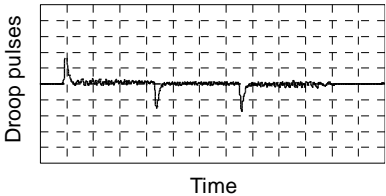
Control	Position command (the same command)	Droop pulses
Normal control		 <p data-bbox="919 804 1262 831">Droop pulses are always generated.</p>
Feed forward gain		 <p data-bbox="919 1099 1382 1151">Droop pulses are generated during acceleration/ deceleration.</p>
Super trace control		 <p data-bbox="919 1420 1370 1469">Droop pulses are almost 0 including the time of acceleration or deceleration.</p>

7. SPECIAL ADJUSTMENT FUNCTIONS

(2) Adjustment procedure

POINT
● In the super trace control, droop pulses are near 0 during the servo motor control. Thus, the normal INP (In-position) may always be turned on. Be sure to set "INP (In-position) on condition selection" in [Pr. PD31] to " _ 1 _ _".
● When you use the super trace control, it is recommended that the acceleration time constant up to the rated speed be set to 1 s or more.

The following shows the adjustment procedure.

Step	Operation
1	Execute the gain adjustment with one-touch tuning, auto tuning, etc. Refer to chapter 6 for details.
2	Change the setting of auto tuning mode to the manual mode ([Pr. PA08]: _ _ _ 3).
3	Change the setting of feed forward gain ([Pr. PB04]), and adjust that droop pulses will be 0 at a constant speed.
4	Set the setting of INP (In-position) on condition selection ([Pr. PD31]) to " _ 1 _ _".
5	Enable the super trace control. ([Pr. PA22]: _ _ 2 _)
6	Change the setting of model loop gain ([Pr. PB07]), and adjust droop pulses during acceleration/deceleration.

8. TROUBLESHOOTING

8. TROUBLESHOOTING.....	2
8.1 Explanations of the lists	2
8.2 Alarm list	3
8.3 Warning list	11
8.4 Remedies for alarms.....	14
8.5 Remedies for warnings	54
8.6 Troubleshooting at power on	65
8.7 Trouble which does not trigger an alarm/warning.....	66

8. TROUBLESHOOTING

8. TROUBLESHOOTING

POINT
<ul style="list-style-type: none"> ● As soon as an alarm occurs, make the servo-off status and interrupt the main circuit power. ● [AL. 37 Parameter error] and warnings (except [AL. F0 Tough drive warning]) are not recorded in the alarm history.

When an error occurs during operation, the corresponding alarm or warning is displayed. If an alarm or warning is displayed, remove the failure. When an alarm occurs, ALM (Malfunction) will turn off.

8.1 Explanations of the lists

(1) No./Name/Detail No./Detail name

Indicates the alarm or warning No., name, detail No., and detail name.

(2) Stop method

For the alarms and warnings in which "SD" is written in the stop method column, the servo motor stops with the dynamic brake after forced stop deceleration. For the alarms and warnings in which "DB" or "EDB" is written in the stop method column, the servo motor stops with the dynamic brake without forced stop deceleration.

(3) Alarm deactivation

After the alarm cause has been removed, the alarm can be deactivated in any of the methods marked ○ in the alarm deactivation column. Warnings are automatically canceled after the cause of occurrence is removed. Alarms are deactivated by alarm reset, communication reset (network), or power cycling.

Alarm deactivation	Explanation
Alarm reset	<ol style="list-style-type: none"> 1. Error reset command from the upper side 2. Click "Occurring Alarm Reset" in the "Alarm Display" window of Setup software (MR Configurator2™).
Communication reset (Network)	<ol style="list-style-type: none"> 1. Disconnect the computer from the network, and connect it again. For details of the disconnection methods, refer to chapter 18,19,20. 2. After the network communication from the upper side has been shifted to the initial state, connect it again.
Cycling the power	Turning the power off and then turning it on again.

8. TROUBLESHOOTING

8.2 Alarm list

	No.	Name	Detail No.	Detail name	Stop method (Note 2, 3)	Alarm deactivation		
						Alarm reset	Communication reset	Cycling the power
Alarm	10	Undervoltage	10.1	Voltage drop in the control circuit power	EDB	○	○	○
			10.2	Voltage drop in the main circuit power	SD	○	○	○
	11	Switch setting error	11.1	Axis number setting error/ Station number setting error	DB	/	/	○
			11.2	Disabling control axis setting error	DB	/	/	○
	12	Memory error 1 (RAM)	12.1	RAM error 1	DB	/	/	○
			12.2	RAM error 2	DB	/	/	○
			12.3	RAM error 3	DB	/	/	○
			12.4	RAM error 4	DB	/	/	○
			12.5	RAM error 5	DB	/	/	○
			12.6	RAM error 6	DB	/	/	○
	13	Clock error	13.1	Clock error 1	DB	/	/	○
			13.2	Clock error 2	DB	/	/	○
	14	Control process error	14.1	Control process error 1	DB	/	/	○
			14.2	Control process error 2	DB	/	/	○
			14.3	Control process error 3	DB	/	/	○
			14.4	Control process error 4	DB	/	/	○
			14.5	Control process error 5	DB	/	/	○
			14.6	Control process error 6	DB	/	/	○
			14.7	Control process error 7	DB	/	/	○
			14.8	Control process error 8	DB	/	/	○
			14.9	Control process error 9	DB	/	/	○
			14.A	Control process error 10	DB	/	/	○
			14.B	Control process error 11	DB	/	/	○
	15	Memory error 2 (EEP-ROM)	15.1	EEP-ROM error at power on	DB	/	/	○
			15.2	EEP-ROM error during operation	DB	/	/	○
			15.4	Home position information read error	DB	/	/	○
	16	Encoder initial communication error 1	16.1	Encoder initial communication - Receive data error 1	DB	/	/	○
			16.2	Encoder initial communication - Receive data error 2	DB	/	/	○
			16.3	Encoder initial communication - Receive data error 3	DB	/	/	○
			16.4	Encoder initial communication - Encoder malfunction (Note 6)	DB	/	/	○
			16.5	Encoder initial communication - Transmission data error 1	DB	/	/	○
			16.6	Encoder initial communication - Transmission data error 2	DB	/	/	○
			16.7	Encoder initial communication - Transmission data error 3	DB	/	/	○
			16.8	Encoder initial communication - Incompatible encoder (Note 6)	DB	/	/	○
			16.A	Encoder initial communication - Process error 1	DB	/	/	○
			16.B	Encoder initial communication - Process error 2	DB	/	/	○
16.C			Encoder initial communication - Process error 3	DB	/	/	○	
16.D			Encoder initial communication - Process error 4	DB	/	/	○	
16.E			Encoder initial communication - Process error 5	DB	/	/	○	
16.F			Encoder initial communication - Process error 6	DB	/	/	○	

8. TROUBLESHOOTING

	No.	Name	Detail No.	Detail name	Stop method (Note 2, 3)	Alarm deactivation		
						Alarm reset	Communication reset	Cycling the power
Alarm	17	Board error	17.1	Board error 1	DB	<input type="checkbox"/>	<input type="checkbox"/>	<input type="checkbox"/>
			17.3	Board error 2	DB	<input type="checkbox"/>	<input type="checkbox"/>	<input type="checkbox"/>
			17.4	Board error 3	DB	<input type="checkbox"/>	<input type="checkbox"/>	<input type="checkbox"/>
			17.5	Board error 4	DB	<input type="checkbox"/>	<input type="checkbox"/>	<input type="checkbox"/>
			17.6	Board error 5	DB	<input type="checkbox"/>	<input type="checkbox"/>	<input type="checkbox"/>
			17.7	Board error 7	DB	<input type="checkbox"/>	<input type="checkbox"/>	<input type="checkbox"/>
			17.8	Board error 6 (Note 6)	EDB	<input type="checkbox"/>	<input type="checkbox"/>	<input type="checkbox"/>
			17.9	Board error 8	DB	<input type="checkbox"/>	<input type="checkbox"/>	<input type="checkbox"/>
	19	Memory error 3 (Flash-ROM)	19.1	Flash-ROM error 1	DB	<input type="checkbox"/>	<input type="checkbox"/>	<input type="checkbox"/>
			19.2	Flash-ROM error 2	DB	<input type="checkbox"/>	<input type="checkbox"/>	<input type="checkbox"/>
			19.3	Flash-ROM error 3	DB	<input type="checkbox"/>	<input type="checkbox"/>	<input type="checkbox"/>
	1A	Servo motor combination error	1A.1	Servo motor combination error 1	DB	<input type="checkbox"/>	<input type="checkbox"/>	<input type="checkbox"/>
			1A.2	Servo motor control mode combination error	DB	<input type="checkbox"/>	<input type="checkbox"/>	<input type="checkbox"/>
			1A.4	Servo motor combination error 2	DB	<input type="checkbox"/>	<input type="checkbox"/>	<input type="checkbox"/>
	1B	Converter error	1B.1	Converter unit error	DB	<input type="checkbox"/>	<input type="checkbox"/>	<input type="checkbox"/>
	1E	Encoder initial communication error 2	1E.1	Encoder malfunction	DB	<input type="checkbox"/>	<input type="checkbox"/>	<input type="checkbox"/>
			1E.2	Load-side encoder malfunction	DB	<input type="checkbox"/>	<input type="checkbox"/>	<input type="checkbox"/>
	1F	Encoder initial communication error 3	1F.1	Incompatible encoder	DB	<input type="checkbox"/>	<input type="checkbox"/>	<input type="checkbox"/>
			1F.2	Incompatible load-side encoder	DB	<input type="checkbox"/>	<input type="checkbox"/>	<input type="checkbox"/>
	20	Encoder normal communication error 1	20.1	Encoder normal communication - Receive data error 1	EDB	<input type="checkbox"/>	<input type="checkbox"/>	<input type="checkbox"/>
			20.2	Encoder normal communication - Receive data error 2	EDB	<input type="checkbox"/>	<input type="checkbox"/>	<input type="checkbox"/>
			20.3	Encoder normal communication - Receive data error 3	EDB	<input type="checkbox"/>	<input type="checkbox"/>	<input type="checkbox"/>
			20.5	Encoder normal communication - Transmission data error 1	EDB	<input type="checkbox"/>	<input type="checkbox"/>	<input type="checkbox"/>
			20.6	Encoder normal communication - Transmission data error 2	EDB	<input type="checkbox"/>	<input type="checkbox"/>	<input type="checkbox"/>
			20.7	Encoder normal communication - Transmission data error 3	EDB	<input type="checkbox"/>	<input type="checkbox"/>	<input type="checkbox"/>
			20.9	Encoder normal communication - Receive data error 4	EDB	<input type="checkbox"/>	<input type="checkbox"/>	<input type="checkbox"/>
			20.A	Encoder normal communication - Receive data error 5	EDB	<input type="checkbox"/>	<input type="checkbox"/>	<input type="checkbox"/>
	21	Encoder normal communication error 2	21.1	Encoder data error 1	EDB	<input type="checkbox"/>	<input type="checkbox"/>	<input type="checkbox"/>
			21.2	Encoder data update error	EDB	<input type="checkbox"/>	<input type="checkbox"/>	<input type="checkbox"/>
			21.3	Encoder data waveform error	EDB	<input type="checkbox"/>	<input type="checkbox"/>	<input type="checkbox"/>
			21.4	Encoder non-signal error	EDB	<input type="checkbox"/>	<input type="checkbox"/>	<input type="checkbox"/>
			21.5	Encoder hardware error 1	EDB	<input type="checkbox"/>	<input type="checkbox"/>	<input type="checkbox"/>
21.6			Encoder hardware error 2	EDB	<input type="checkbox"/>	<input type="checkbox"/>	<input type="checkbox"/>	
21.9			Encoder data error 2	EDB	<input type="checkbox"/>	<input type="checkbox"/>	<input type="checkbox"/>	
24	Main circuit error	24.1	Ground fault detected by hardware detection circuit	DB	<input type="checkbox"/>	<input type="checkbox"/>	<input type="checkbox"/>	
		24.2	Ground fault detected by software detection function	DB	<input type="checkbox"/>	<input type="checkbox"/>	<input type="checkbox"/>	
25	Absolute position erased	25.1	Servo motor encoder - Absolute position erased	DB	<input type="checkbox"/>	<input type="checkbox"/>	<input type="checkbox"/>	
		25.2	Scale measurement encoder - Absolute position erased	DB	<input type="checkbox"/>	<input type="checkbox"/>	<input type="checkbox"/>	

8. TROUBLESHOOTING

	No.	Name	Detail No.	Detail name	Stop method (Note 2, 3)	Alarm deactivation		
						Alarm reset	Communication reset	Cycling the power
Alarm	27	Initial magnetic pole detection error	27.1	Initial magnetic pole detection - Abnormal termination	DB	○	○	○
			27.2	Initial magnetic pole detection - Time out error	DB	○	○	○
			27.3	Initial magnetic pole detection - Limit switch error	DB	○	○	○
			27.4	Initial magnetic pole detection - Estimated error	DB	○	○	○
			27.5	Initial magnetic pole detection - Position deviation error	DB	○	○	○
			27.6	Initial magnetic pole detection - Speed deviation error	DB	○	○	○
			27.7	Initial magnetic pole detection - Current error	DB	○	○	○
	28	Linear encoder error 2	28.1	Linear encoder - Environment error	EDB	○	○	○
	2A	Linear encoder error 1	2A.1	Linear encoder error 1-1	EDB	○	○	○
			2A.2	Linear encoder error 1-2	EDB	○	○	○
			2A.3	Linear encoder error 1-3	EDB	○	○	○
			2A.4	Linear encoder error 1-4	EDB	○	○	○
			2A.5	Linear encoder error 1-5	EDB	○	○	○
			2A.6	Linear encoder error 1-6	EDB	○	○	○
			2A.7	Linear encoder error 1-7	EDB	○	○	○
			2A.8	Linear encoder error 1-8	EDB	○	○	○
	2B	Encoder counter error	2B.1	Encoder counter error 1	EDB	○	○	○
			2B.2	Encoder counter error 2	EDB	○	○	○
	30	Regenerative error	30.1	Regeneration heat error	DB	○ (Note 1)	○ (Note 1)	○ (Note 1)
			30.2	Regeneration signal error	DB	○ (Note 1)	○ (Note 1)	○ (Note 1)
			30.3	Regeneration feedback signal error	DB	○ (Note 1)	○ (Note 1)	○ (Note 1)
	31	Overspeed	31.1	Abnormal motor speed	SD	○	○	○
	32	Overcurrent	32.1	Overcurrent detected at hardware detection circuit (during operation)	DB	○	○	○
			32.2	Overcurrent detected at software detection function (during operation)	DB	○	○	○
			32.3	Overcurrent detected at hardware detection circuit (during a stop)	DB	○	○	○
			32.4	Overcurrent detected at software detection function (during a stop)	DB	○	○	○
	33	Overvoltage	33.1	Main circuit voltage error	EDB	○	○	○
	34	SSCNET receive error 1	34.1	SSCNET receive data error	SD	○	○ (Note 5)	○
			34.2	SSCNET connector connection error	SD	○	○	○
			34.3	SSCNET communication data error	SD	○	○	○
			34.4	Hardware error signal detection	SD	○	○	○
			34.5	SSCNET receive data error (safety observation function)	SD	○	○	○
			34.6	SSCNET communication data error (safety observation function)	SD	○	○	○
	35	Command frequency error	35.1	Command frequency error	SD	○	○	○
	36	SSCNET receive error 2	36.1	Continuous communication data error	SD	○	○	○
			36.2	Continuous communication data error (safety observation function)	SD	○	○	○
	37	Parameter error	37.1	Parameter setting range error	DB	○	○	○
			37.2	Parameter combination error	DB	○	○	○
			37.3	Point table setting error	DB	○	○	○
			37.4	Command electronic gear setting error 2	DB	○	○	○

8. TROUBLESHOOTING

	No.	Name	Detail No.	Detail name	Stop method (Note 2, 3)	Alarm deactivation		
						Alarm reset	Communication reset	Cycling the power
Alarm	39	Program error	39.1	Program error	DB	<input type="checkbox"/>	<input type="checkbox"/>	<input type="checkbox"/>
			39.2	Instruction argument external error	DB	<input type="checkbox"/>	<input type="checkbox"/>	<input type="checkbox"/>
			39.3	Register No. error	DB	<input type="checkbox"/>	<input type="checkbox"/>	<input type="checkbox"/>
			39.4	Non-correspondence instruction error	DB	<input type="checkbox"/>	<input type="checkbox"/>	<input type="checkbox"/>
	3A	Inrush current suppression circuit error	3A.1	Inrush current suppression circuit error	EDB	<input type="checkbox"/>	<input type="checkbox"/>	<input type="checkbox"/>
	3D	Parameter setting error for driver communication	3D.1	Parameter combination error for driver communication on slave	DB	<input type="checkbox"/>	<input type="checkbox"/>	<input type="checkbox"/>
			3D.2	Parameter combination error for driver communication on master	DB	<input type="checkbox"/>	<input type="checkbox"/>	<input type="checkbox"/>
	3E	Operation mode error	3E.1	Operation mode error	DB	<input type="checkbox"/>	<input type="checkbox"/>	<input type="checkbox"/>
			3E.6	Operation mode switch error	DB	<input type="checkbox"/>	<input type="checkbox"/>	<input type="checkbox"/>
	42	Servo control error (for linear servo motor and direct drive motor)	42.1	Servo control error by position deviation	EDB	(Note 4)	(Note 4)	<input type="checkbox"/>
			42.2	Servo control error by speed deviation	EDB	(Note 4)	(Note 4)	<input type="checkbox"/>
			42.3	Servo control error by torque/thrust deviation	EDB	(Note 4)	(Note 4)	<input type="checkbox"/>
		Fully closed loop control error (for fully closed loop control)	42.8	Fully closed loop control error by position deviation	EDB	(Note 4)	(Note 4)	<input type="checkbox"/>
			42.9	Fully closed loop control error by speed deviation	EDB	(Note 4)	(Note 4)	<input type="checkbox"/>
			42.A	Fully closed loop control error by position deviation during command stop	EDB	(Note 4)	(Note 4)	<input type="checkbox"/>
	45	Main circuit device overheat	45.1	Main circuit device overheat error 1	SD	<input type="checkbox"/> (Note 1)	<input type="checkbox"/> (Note 1)	<input type="checkbox"/> (Note 1)
			45.2	Main circuit device overheat error 2	SD	<input type="checkbox"/> (Note 1)	<input type="checkbox"/> (Note 1)	<input type="checkbox"/> (Note 1)
	46	Servo motor overheat	46.1	Abnormal temperature of servo motor 1	SD	<input type="checkbox"/> (Note 1)	<input type="checkbox"/> (Note 1)	<input type="checkbox"/> (Note 1)
			46.2	Abnormal temperature of servo motor 2	SD	<input type="checkbox"/> (Note 1)	<input type="checkbox"/> (Note 1)	<input type="checkbox"/> (Note 1)
			46.3	Thermistor disconnected error	SD	<input type="checkbox"/> (Note 1)	<input type="checkbox"/> (Note 1)	<input type="checkbox"/> (Note 1)
			46.4	Thermistor circuit error	SD	<input type="checkbox"/> (Note 1)	<input type="checkbox"/> (Note 1)	<input type="checkbox"/> (Note 1)
			46.5	Abnormal temperature of servo motor 3	DB	<input type="checkbox"/> (Note 1)	<input type="checkbox"/> (Note 1)	<input type="checkbox"/> (Note 1)
			46.6	Abnormal temperature of servo motor 4	DB	<input type="checkbox"/> (Note 1)	<input type="checkbox"/> (Note 1)	<input type="checkbox"/> (Note 1)
	47	Cooling fan error	47.1	Cooling fan stop error	SD	<input type="checkbox"/>	<input type="checkbox"/>	<input type="checkbox"/>
			47.2	Cooling fan speed reduction error	SD	<input type="checkbox"/>	<input type="checkbox"/>	<input type="checkbox"/>
	50	Overload 1	50.1	Thermal overload error 1 during operation	SD	<input type="checkbox"/> (Note 1)	<input type="checkbox"/> (Note 1)	<input type="checkbox"/> (Note 1)
			50.2	Thermal overload error 2 during operation	SD	<input type="checkbox"/> (Note 1)	<input type="checkbox"/> (Note 1)	<input type="checkbox"/> (Note 1)
			50.3	Thermal overload error 4 during operation	SD	<input type="checkbox"/> (Note 1)	<input type="checkbox"/> (Note 1)	<input type="checkbox"/> (Note 1)
			50.4	Thermal overload error 1 during a stop	SD	<input type="checkbox"/> (Note 1)	<input type="checkbox"/> (Note 1)	<input type="checkbox"/> (Note 1)
			50.5	Thermal overload error 2 during a stop	SD	<input type="checkbox"/> (Note 1)	<input type="checkbox"/> (Note 1)	<input type="checkbox"/> (Note 1)
			50.6	Thermal overload error 4 during a stop	SD	<input type="checkbox"/> (Note 1)	<input type="checkbox"/> (Note 1)	<input type="checkbox"/> (Note 1)
	51	Overload 2	51.1	Thermal overload error 3 during operation	DB	<input type="checkbox"/> (Note 1)	<input type="checkbox"/> (Note 1)	<input type="checkbox"/> (Note 1)
			51.2	Thermal overload error 3 during a stop	DB	<input type="checkbox"/> (Note 1)	<input type="checkbox"/> (Note 1)	<input type="checkbox"/> (Note 1)
52	Error excessive	52.1	Excess droop pulse 1	SD	<input type="checkbox"/>	<input type="checkbox"/>	<input type="checkbox"/>	
		52.3	Excess droop pulse 2	SD	<input type="checkbox"/>	<input type="checkbox"/>	<input type="checkbox"/>	
		52.4	Error excessive during 0 torque limit	SD	<input type="checkbox"/>	<input type="checkbox"/>	<input type="checkbox"/>	
		52.5	Excess droop pulse 3	EDB	<input type="checkbox"/>	<input type="checkbox"/>	<input type="checkbox"/>	

8. TROUBLESHOOTING

	No.	Name	Detail No.	Detail name	Stop method (Note 2, 3)	Alarm deactivation		
						Alarm reset	Communication reset	Cycling the power
Alarm	54	Oscillation detection	54.1	Oscillation detection error	EDB	○	○	○
	56	Forced stop error	56.2	Over speed during forced stop	EDB	○	○	○
			56.3	Estimated distance over during forced stop	EDB	○	○	○
	61	Operation error	61.1	Point table setting range error	DB	○	△	○
	63	STO timing error	63.1	STO1 off	DB	○	○	○
			63.2	STO2 off	DB	○	○	○
			63.5	STO by functional safety unit	DB	○	○	○
	64	Functional safety unit setting error	64.1	STO input error	DB	△	△	○
			64.2	Compatibility mode setting error	DB	△	△	○
			64.3	Operation mode setting error	DB	△	△	○
	65	Functional safety unit connection error	65.1	Functional safety unit communication error 1	SD	△	△	○
			65.2	Functional safety unit communication error 2	SD	△	△	○
			65.3	Functional safety unit communication error 3	SD	△	△	○
			65.4	Functional safety unit communication error 4	SD	△	△	○
			65.5	Functional safety unit communication error 5	SD	△	△	○
			65.6	Functional safety unit communication error 6	SD	△	△	○
			65.7	Functional safety unit communication error 7	SD	△	△	○
			65.8	Functional safety unit shut-off signal error 1	DB	△	△	○
			65.9	Functional safety unit shut-off signal error 2	DB	△	△	○
	66	Encoder initial communication error (safety observation function)	66.1	Encoder initial communication - Receive data error 1 (safety observation function)	DB	△	△	○
			66.2	Encoder initial communication - Receive data error 2 (safety observation function)	DB	△	△	○
			66.3	Encoder initial communication - Receive data error 3 (safety observation function)	DB	△	△	○
			66.7	Encoder initial communication - Transmission data error 1 (safety observation function)	DB	△	△	○
			66.9	Encoder initial communication - Process error 1 (safety observation function)	DB	△	△	○
	67	Encoder normal communication error 1 (safety observation function)	67.1	Encoder normal communication - Receive data error 1 (safety observation function)	DB	△	△	○
			67.2	Encoder normal communication - Receive data error 2 (safety observation function)	DB	△	△	○
			67.3	Encoder normal communication - Receive data error 3 (safety observation function)	DB	△	△	○
			67.4	Encoder normal communication - Receive data error 4 (safety observation function)	DB	△	△	○
67.7			Encoder normal communication - Transmission data error 1 (safety observation function)	DB	△	△	○	
68	STO diagnosis error	68.1	Mismatched STO signal error	DB	△	△	○	

8. TROUBLESHOOTING

	No.	Name	Detail No.	Detail name	Stop method (Note 2, 3)	Alarm deactivation		
						Alarm reset	Communication reset	Cycling the power
Alarm	69	Command error	69.1	Forward rotation-side software limit detection - Command excess error	SD	○	○	○
			69.2	Reverse rotation-side software limit detection - Command excess error	SD	○	○	○
			69.3	Forward rotation stroke end detection - Command excess error	SD	○	○	○
			69.4	Reverse rotation stroke end detection - Command excess error	SD	○	○	○
			69.5	Upper stroke limit detection - Command excess error	SD	○	○	○
			69.6	Lower stroke limit detection - Command excess error	SD	○	○	○
	70	Load-side encoder initial communication error 1	70.1	Load-side encoder initial communication - Receive data error 1	DB	/	/	○
			70.2	Load-side encoder initial communication - Receive data error 2	DB	/	/	○
			70.3	Load-side encoder initial communication - Receive data error 3	DB	/	/	○
			70.4	Load-side encoder initial communication - Encoder malfunction (Note 6)	DB	/	/	○
			70.5	Load-side encoder initial communication - Transmission data error 1	DB	/	/	○
			70.6	Load-side encoder initial communication - Transmission data error 2	DB	/	/	○
			70.7	Load-side encoder initial communication - Transmission data error 3	DB	/	/	○
			70.8	Load-side encoder initial communication - Incompatible encoder (Note 6)	DB	/	/	○
			70.A	Load-side encoder initial communication - Process error 1	DB	/	/	○
			70.B	Load-side encoder initial communication - Process error 2	DB	/	/	○
			70.C	Load-side encoder initial communication - Process error 3	DB	/	/	○
			70.D	Load-side encoder initial communication - Process error 4	DB	/	/	○
70.E			Load-side encoder initial communication - Process error 5	DB	/	/	○	
70.F			Load-side encoder initial communication - Process error 6	DB	/	/	○	
71	Load-side encoder normal communication error 1	71.1	Load-side encoder normal communication - Receive data error 1	EDB	/	/	○	
		71.2	Load-side encoder normal communication - Receive data error 2	EDB	/	/	○	
		71.3	Load-side encoder normal communication - Receive data error 3	EDB	/	/	○	
		71.5	Load-side encoder normal communication - Transmission data error 1	EDB	/	/	○	
		71.6	Load-side encoder normal communication - Transmission data error 2	EDB	/	/	○	
		71.7	Load-side encoder normal communication - Transmission data error 3	EDB	/	/	○	
		71.9	Load-side encoder normal communication - Receive data error 4	EDB	/	/	○	
		71.A	Load-side encoder normal communication - Receive data error 5	EDB	/	/	○	

8. TROUBLESHOOTING

	No.	Name	Detail No.	Detail name	Stop method (Note 2, 3)	Alarm deactivation			
						Alarm reset	Communication reset	Cycling the power	
Alarm	72	Load-side encoder normal communication error 2	72.1	Load-side encoder data error 1	EDB	/	/	○	
			72.2	Load-side encoder data update error	EDB	/	/	○	
			72.3	Load-side encoder data waveform error	EDB	/	/	○	
			72.4	Load-side encoder non-signal error	EDB	/	/	○	
			72.5	Load-side encoder hardware error 1	EDB	/	/	○	
			72.6	Load-side encoder hardware error 2	EDB	/	/	○	
				72.9	Load-side encoder data error 2	EDB	/	/	○
	74	Option card error 1	74.1	Option card error 1	DB	/	/	○	
			74.2	Option card error 2	DB	/	/	○	
			74.3	Option card error 3	DB	/	/	○	
			74.4	Option card error 4	DB	/	/	○	
			74.5	Option card error 5	DB	/	/	○	
	75	Option card error 2	75.3	Option card connection error	EDB	/	/	○	
			75.4	Option card disconnected	DB	/	/	○	
	79	Functional safety unit diagnosis error	79.1	Functional safety unit power voltage error	DB	○ (Note 7)	/	○	
			79.2	Functional safety unit internal error	DB	/	/	○	
			79.3	Abnormal temperature of functional safety unit	SD	○ (Note 7)	/	○	
			79.4	Driver error	SD	/	/	○	
			79.5	Input device error	SD	/	/	○	
			79.6	Output device error	SD	/	/	○	
			79.7	Mismatched input signal error	SD	/	/	○	
			79.8	Position feedback fixing error	DB	/	/	○	
	7A	Parameter setting error (safety observation function)	7A.1	Parameter verification error (safety observation function)	DB	/	/	○	
			7A.2	Parameter setting range error (safety observation function)	DB	/	/	○	
			7A.3	Parameter combination error (safety observation function)	DB	/	/	○	
			7A.4	Functional safety unit combination error (safety observation function)	DB	/	/	○	
	7B	Encoder diagnosis error (safety observation function)	7B.1	Encoder diagnosis error 1 (safety observation function)	DB	/	/	○	
			7B.2	Encoder diagnosis error 2 (safety observation function)	DB	/	/	○	
			7B.3	Encoder diagnosis error 3 (safety observation function)	DB	/	/	○	
			7B.4	Encoder diagnosis error 4 (safety observation function)	DB	/	/	○	
	7C	Functional safety unit communication diagnosis error (safety observation function)	7C.1	Functional safety unit communication setting error (safety observation function)	SD	○ (Note 7)	○	○	
			7C.2	Functional safety unit communication data error (safety observation function)	SD	○ (Note 7)	○	○	
	7D	Safety observation error	7D.1	Stop observation error	DB	○ (Note 3)	/	○	
			7D.2	Speed observation error	DB	○ (Note 7)	/	○	
	82	Master-slave operation error 1	82.1	Master-slave operation error 1	EDB	○	○	○	
	84	Network card initialization error	84.1	Network card undetected error	DB	/	/	○	
			84.2	Network card initialization error 1	DB	/	/	○	
			84.3	Network card initialization error 2	DB	/	/	○	
	85	Network card error	85.1	Network card error 1	SD	/	/	○	
			85.2	Network card error 2	SD	/	/	○	
			85.3	Network card error 3	SD	/	/	○	

8. TROUBLESHOOTING

	No.	Name	Detail No.	Detail name	Stop method (Note 2, 3)	Alarm deactivation		
						Alarm reset	Communication reset	Cycling the power
Alarm	86	Network communication error	86.1	Network communication error 1	SD	○	△	○
			86.2	Network communication error 2	SD	○	△	○
			86.3	Network communication error 3	SD	○	△	○
	8A	USB communication time-out error/ serial communication time-out error/ Modbus RTU communication time-out error	8A.1	USB communication time-out error/serial communication time-out error	SD	○	○	○
			8A.2	Modbus RTU communication time-out error	SD	○	○	○
	8D	CC-Link IE communication error	8D.1	CC-Link IE communication error 1	SD	○	△	○
			8D.2	CC-Link IE communication error 2	SD	○	△	○
			8D.3	Master station setting error 1	DB	○	△	○
			8D.5	Master station setting error 2	DB	△	△	○
			8D.6	CC-Link IE communication error 3	SD	○	△	○
			8D.7	CC-Link IE communication error 4	SD	○	△	○
			8D.8	CC-Link IE communication error 5	SD	○	△	○
			8D.9	Synchronization error 1	SD	△	△	○
			8D.A	Synchronization error 2	SD	△	△	○
	8E	USB communication error/ serial communication error/ Modbus RTU communication error	8E.1	USB communication receive error/serial communication receive error	SD	○	○	○
			8E.2	USB communication checksum error/serial communication checksum error	SD	○	○	○
			8E.3	USB communication character error/serial communication character error	SD	○	○	○
			8E.4	USB communication command error/serial communication command error	SD	○	○	○
			8E.5	USB communication data number error/serial communication data number error	SD	○	○	○
			8E.6	Modbus RTU communication receive error	SD	○	○	○
			8E.7	Modbus RTU communication message frame error	SD	○	○	○
			8E.8	Modbus RTU communication CRC error	SD	○	○	○
	88888	Watchdog	8888_	Watchdog	DB	△	△	○

Note 1. After resolving the source of trouble, cool the equipment for approximately 30 minutes.

2. The following shows three stop methods of DB, EDB, and SD.

DB: Stops with dynamic brake. (Coasts for the driver without dynamic brake.)

[AL. 30.1], [AL. 32.2], [AL. 32.4], [AL. 51.1], [AL. 51.2], [AL. 888]

EDB: Electronic dynamic brake stop (Only valid for servo motors of 100 to 400W)

The stop method for 750W servo motor will be DB.

SD: Forced stop deceleration

3. This is applicable when [Pr. PA04] is set to the initial value. The stop system of SD can be changed to DB using [Pr. PA04].

5. In some upper side communication status, the alarm factor may not be removed.

7. Reset this while all the safety observation functions are stopped.

8. TROUBLESHOOTING

8.3 Warning list

	No.	Name	Detail No.	Detail name	Stop method (Note 2, 3)
Warning	90	Home position return incomplete warning	90.1	Home position return incomplete	
			90.2	Home position return abnormal termination	
			90.5	Z-phase unpassed	
	91	Driver overheat warning (Note 1)	91.1	Main circuit device overheat warning	
	92	Battery cable disconnection warning	92.1	Encoder battery cable disconnection warning	
			92.3	Battery degradation	
	93	ABS data transfer warning	93.1	ABS data transfer requirement warning during magnetic pole detection	
	95	STO warning	95.1	STO1 off detection	DB
			95.2	STO2 off detection	DB
			95.3	STO warning 1 (safety observation function)	DB
			95.4	STO warning 2 (safety observation function)	DB
			95.5	STO warning 3 (safety observation function)	DB
	96	Home position setting warning	96.1	In-position warning at home positioning	
			96.2	Command input warning at home positioning	
			96.3	Servo off warning at home positioning	
			96.4	Home positioning warning during magnetic pole detection	
	97	Positioning specification warning	97.1	Program operation disabled warning	
			97.2	Next station position warning	
	98	Software limit warning	98.1	Forward rotation-side software stroke limit reached	
			98.2	Reverse rotation-side software stroke limit reached	
	99	Stroke limit warning	99.1	Forward rotation stroke end off	(Note 4)
			99.2	Reverse rotation stroke end off	(Note 4)
			99.4	Upper stroke limit off	
			99.5	Lower stroke limit off	
	9A	Optional unit input data error warning	9A.1	Optional unit input data sign error	
			9A.2	Optional unit BCD input data error	
	9B	Error excessive warning	9B.1	Excess droop pulse 1 warning	
			9B.3	Excess droop pulse 2 warning	
			9B.4	Error excessive warning during 0 torque limit	
	9C	Converter error	9C.1	Converter unit error	
	9D	CC-Link IE warning 1	9D.1	Station number switch change warning	
			9D.2	Master station setting warning	
			9D.3	Overlapping station number warning	
			9D.4	Mismatched station number warning	
	9E	CC-Link IE warning 2	9E.1	CC-Link IE communication warning	
	9F	Battery warning	9F.1	Low battery	
			9F.2	Battery degradation warning	
	E0	Excessive regeneration warning	E0.1	Excessive regeneration warning	

8. TROUBLESHOOTING

	No.	Name	Detail No.	Detail name	Stop method (Note 2, 3)
Warning	E1	Overload warning 1	E1.1	Thermal overload warning 1 during operation	
			E1.2	Thermal overload warning 2 during operation	
			E1.3	Thermal overload warning 3 during operation	
			E1.4	Thermal overload warning 4 during operation	
			E1.5	Thermal overload error 1 during a stop	
			E1.6	Thermal overload error 2 during a stop	
			E1.7	Thermal overload error 3 during a stop	
			E1.8	Thermal overload error 4 during a stop	
	E2	Servo motor overheat warning	E2.1	Servo motor temperature warning	
	E3	Absolute position counter warning	E3.1	Multi-revolution counter travel distance excess warning	
			E3.2	Absolute position counter warning	
			E3.4	Absolute positioning counter EEPROM writing frequency warning	
			E3.5	Encoder absolute positioning counter warning	
	E4	Parameter warning	E4.1	Parameter setting range error warning	
	E5	ABS time-out warning	E5.1	Time-out during ABS data transfer	
			E5.2	ABSM off during ABS data transfer	
			E5.3	SON off during ABS data transfer	
	E6	Servo forced stop warning	E6.1	Forced stop warning	SD
			E6.2	SS1 forced stop warning 1 (safety observation function)	SD
			E6.3	SS1 forced stop warning 2 (safety observation function)	SD
	E7	Upper side forced stop warning	E7.1	Upper side forced stop input warning	SD
	E8	Cooling fan speed reduction warning	E8.1	Decreased cooling fan speed warning	
			E8.2	Cooling fan stop	
	E9	Main circuit off warning	E9.1	Servo-on signal on during main circuit off	DB
			E9.2	Bus voltage drop during low speed operation	DB
			E9.3	Ready-on signal on during main circuit off	DB
			E9.4	Converter unit forced stop	DB
	EA	ABS servo-on warning	EA.1	ABS servo-on warning	
	EB	The other axis error warning	EB.1	The other axis error warning	DB
	EC	Overload warning 2	EC.1	Overload warning 2	
	ED	Output watt excess warning	ED.1	Output watt excess warning	
	F0	Tough drive warning	F0.1	Instantaneous power failure tough drive warning	
			F0.3	Vibration tough drive warning	
F2	Drive recorder - Miswriting warning	F2.1	Drive recorder - Area writing time-out warning		
		F2.2	Drive recorder - Data miswriting warning		
F3	Oscillation detection warning	F3.1	Oscillation detection warning		

8. TROUBLESHOOTING

	No.	Name	Detail No.	Detail name	Stop method (Note 2, 3)
Warning	F4	Positioning warning	F4.4	Target position setting range error warning	
			F4.6	Acceleration time constant setting range error warning	
			F4.7	Deceleration time constant setting range error warning	
			F4.8	Control command input error warning	
			F4.9	Home position return type error warning	
	F5	Simple cam function - Cam data miswriting warning	F5.1	Cam data - Area writing time-out warning	
			F5.2	Cam data - Area miswriting warning	
			F5.3	Cam data checksum error	
	F6	Simple cam function - Cam control warning	F6.1	Cam axis one cycle current value restoration failed	
			F6.2	Cam axis feed current value restoration failed	
			F6.3	Cam unregistered error	
			F6.4	Cam control data setting range error	
			F6.5	Cam No. external error	
			F6.6	Cam control inactive	
	F7	Machine diagnosis warning	F7.1	Vibration failure prediction warning	
			F7.2	Friction failure prediction warning	
			F7.3	Total travel distance failure prediction warning	

- Note 1. After resolving the source of trouble, cool the equipment for approximately 30 minutes.
2. The following shows two stop methods of DB and SD.
 DB: Stops with dynamic brake. (Coasts for the driver without dynamic brake.)
 SD: Forced stop deceleration
3. This is applicable when [Pr. PA04] is set to the initial value. The stop system of SD can be changed to DB using [Pr. PA04].

8. TROUBLESHOOTING

8.4 Remedies for alarms

CAUTION

- When an alarm occurs, eliminate its cause, ensure safety, and deactivate the alarm to restart operation. Otherwise, it may cause injury.
- If [AL. 25 Absolute position erased] occurs, always make home position setting again. Otherwise, it may cause an unexpected operation.
- As soon as an alarm occurs, make the Servo-off status and interrupt the main circuit power.

POINT

- When any of the following alarms occurs, do not deactivate the alarm repeatedly to restart. Doing so will cause a malfunction of the driver and servo motor. Remove its cause and allow 30 minutes or more for cooling, and then resume the operation.
 - [AL. 30 Regenerative error] ▪ [AL. 45 Main circuit device overheat]
 - [AL. 46 Servo motor overheat] ▪ [AL. 50 Overload 1]
 - [AL. 51 Overload 2]
- [AL. 37 Parameter error] is not recorded in the alarm history.

Refer to this section and remedies for alarms, remove the cause of the alarm.

Use Setup software (MR Configurator2™) to refer for the cause of alarm occurrence.

8. TROUBLESHOOTING

Alarm No.: 10		Name: Undervoltage				
Alarm content		The voltage of the control circuit power supply has dropped. The voltage of the main circuit power supply has dropped.				
Detail No.	Detail name	Cause	Check method	Check result	Action	
10.1	Voltage drop in the control circuit power	(1)	The control circuit power supply connection is incorrect.	Check the connection of the control circuit power supply.	It has a failure.	Connect it correctly.
					It has no failure.	Check (2).
		(2)	The voltage of the control circuit power supply is low.	Check if the voltage of the control circuit power supply is lower than prescribed value. 160 V AC	The voltage is the prescribed value or lower.	Review the voltage of the control circuit power supply.
					The voltage is higher than the prescribed value.	Check (3).
		(3)	The power was cycled before the internal control circuit power supply stopped.	Check if the power has a problem.	It has a problem.	Cycle the power after the seven-segment LED of the driver is turned off.
					It has no problem.	Check (4).
		(4)	An instantaneous power failure has occurred for longer time than the specified time. The time will be 60 ms when [Pr. PA20] is "_ 0 _ _". The time will be the value set in [Pr. PF25] when [Pr. PA20] is "_ 1 _ _". The time will be 60 ms when [Pr. PX25] is "_ 0 _ _" and the J3 extension function is used. The time will be the value set in [Pr. PX28] when [Pr. PX25] is "_ 1 _ _".	Check if the power has a problem.	It has a problem.	Review the power.
					It has no problem.	Check (5).
		(5)	When a power regeneration converter is used, the voltage of the control circuit power supply is distorted.	Check if the power has a problem. When power supply impedance is high, power supply voltage will be distorted due to current at power regeneration, and it may be recognized as undervoltage.	It has no problem.	Review the setting of "[AL. 10 Undervoltage] detection method selection" with the following parameters. [Pr. PC27]
		10.2	Voltage drop in the main circuit power	(1)	The main circuit power supply wiring was disconnected. For the drive unit, the main circuit power supply wiring of the converter unit was disconnected.	Check the main circuit power supply wiring. Check the main circuit power supply wiring of the converter unit.
It is connected.	Check (2).					
(2)	The wiring between P3 and P4 was disconnected. For the drive unit, the wiring between P1 and P2 of the converter unit was disconnected.			Check the wiring between P3 and P4. Check the wiring between P1 and P2 of the converter unit.	It is disconnected.	Connect it correctly.
					It is connected.	Check (3).
(3)	For the drive unit, the magnetic contactor control connector of the converter unit was			Check the magnetic contactor control connector of the converter unit.	It is disconnected.	Connect it correctly.
					It has no failure.	It is disconnected.

8. TROUBLESHOOTING

		disconnected.			
		(4) For the drive unit, the bus bar between the converter unit and drive unit was disconnected	Check the bus bar between the converter unit and drive unit.	It is disconnected. It has no failure.	Connect it correctly. Check (5).
		(5) The voltage of the main circuit power supply is low.	Check if the voltage of the main circuit power supply is the prescribed value or lower. 160 V AC	The voltage is the prescribed value or lower. The voltage is higher than the prescribed value.	Increase the voltage of the main circuit power supply. Check (6).
		(6) The alarm has occurred during acceleration.	Check if the bus voltage during acceleration is lower than the prescribed value. 200 V DC	The voltage is lower than the prescribed value. The voltage is equal to or higher than the prescribed value.	Increase the acceleration time constant. Or increase the power supply capacity. Check (7).

Alarm No.: 12		Name: Memory error 1 (RAM)			
Alarm content		• A part (RAM) in the driver is failure.			
Detail No.	Detail name	Cause	Check method	Check result	Action
12.1	RAM error 1	(1) A part in the driver is failure.	Disconnect the cables except for the control circuit power supply, and then check the repeatability	It is repeatable. It is not repeatable	Replace the driver. Check (2).
		(2) Something near the device caused it.	Check the power supply for noise.	There is a problem in the surrounding	Take countermeasures against its cause.
12.2	RAM error 2	Check it with the check method for [AL. 12.1].			
12.3	RAM error 3				
12.4	RAM error 4				
12.5	RAM error 5				
12.6	RAM error 6				

Alarm No.: 13		Name: Clock error			
Alarm content		A part in the servo driver. •A clock error transmitted from the controller occurred.			
Detail No.	Detail name	Cause	Check method	Check result	Action
13.1	Clock error 1	(1) A part in the driver is failure.	Disconnect the cables except for the control circuit power supply, and then check the repeatability.	It is occurring.	Replace the driver.
		(2) Something near the device caused it.	Check the power supply for noise. Check if the connector is shorted.	There is a problem in the surrounding.	Take countermeasures against its cause.
13.2	Clock error 2	Check it with the check method for [AL. 13.1].			

8. TROUBLESHOOTING

Alarm No.: 14		Name: Control process error				
Alarm content		•The process did not complete within the specified time.				
Detail No.	Detail name	Cause		Check method	Check result	Action
14.1	Control process error 1	(1)	The parameter setting is incorrect.	Check if the parameter setting is incorrect.	It is incorrect.	Set it correctly.
					It is correct.	Check (3).
		(2)	Something near the device caused it.	Check the power supply for noise. Check if the connector is shorted	There is a problem in the surrounding.	Take countermeasures against its cause.
					There is no problem in the surrounding.	Check (4).
		(3)	The driver is malfunctioning.	Replace the driver, and then check the repeatability.	It is not repeatable.	Replace the driver.
		14.2	Control process error 2	(1)	The parameter setting is incorrect.	Check if the parameter setting is incorrect.
It is correct.	Check (5).					
(2)	Something near the device caused it.			Check the power supply for noise. Check if the connector is shorted.	There is a problem in the surrounding.	Take countermeasures against its cause.
					There is no problem in the surrounding.	Check (6).
(3)	The driver is malfunctioning.			Replace the driver, and then check the repeatability.	It is not repeatable.	Replace the driver.
14.3	Control process error 3			Check it with the check method for [AL. 14.1].		
14.4	Control process error 4					
14.5	Control process error 5					
14.6	Control process error 6					
14.7	Control process error 7					
14.8	Control process error 8					
14.9	Control process error 9					
14.A	Control process error 10					
14.B	Control process error 11	(1)	The parameter setting is incorrect.	Check if the parameter setting is incorrect.	It is incorrect.	Set it correctly.
					It is correct.	Check (3).
		(2)	Something near the device caused it.	Check the power supply for noise. Check if the connector is shorted.	It has a failure.	Take countermeasures against its cause.
					It has no failure.	Check (4).
		(3)	The driver is malfunctioning	Replace the driver, and then check the repeatability.	It is not repeatable.	Replace the driver.
		14.C	Control process error 12	Check it with the check method for [AL. 14.B].		
14.D	Control process error 13					

8. TROUBLESHOOTING

Alarm No.: 15		Name: Memory error 2 (EEP-ROM)				
Alarm content		A part (EEP-ROM) in the driver is failure.				
Detail No.	Detail name	Cause	Check method	Check result	Action	
15.1	EEP-ROM error at power on	(1)	EEP-ROM is malfunctioning at power on.	Disconnect the cables except for the control circuit power supply, and then check the repeatability.	It is repeatable.	Replace the driver.
					It is not repeatable.	Check (2).
		(2)	Something near the device caused it.	Check the power supply for noise. Check if the connector is shorted	There is a problem in the surrounding.	Take countermeasures against its cause.
					There is no problem in the surrounding.	Check (3).
(3)	The number of write times exceeded 100,000.	Check if parameters, point tables, or programs are changed very frequently.	It was changed.	Replace the driver. Change the process to use parameters, point tables, and programs less frequently after replacement.		
15.2	EEP-ROM error During operation	(1)	EEP-ROM is malfunctioning during normal operation.	Check if the error occurs when you change parameters during normal operation.	It occurs.	Replace the driver.
					It does not occur.	Check (3).
		(2)	A write error occurred while adjustment results were processed.	Check if the alarm occurs after an hour from power on.	It takes an hour or more	Replace the driver.
					It takes less than an hour.	Check (4).
(3)	Something near the device caused it.	Check the power supply for noise. Check if the connector is shorted.	There is a problem in the surrounding.	Take countermeasures against its cause.		
15.4	Home position information read error	(1)	EEP-ROM is malfunctioning at power on.	Disconnect the cables except for the control circuit power supply, and then check the repeatability.	It is repeatable.	Replace the driver.
					It is not repeatable.	Check (2).
		(2)	Multiple rotation data saved as a home position and read from EEPROM were failure.	Check if the home position was set correctly.	It is repeatable.	Replace the driver.
					It is not repeatable.	Check (3).
(3)	Something near the device caused it.	Check the power supply for noise. Check if the connector is shorted.	There is a problem in the surrounding.	Take countermeasures against its cause.		
			There is no problem in the surrounding.	Check (4).		
(4)	The number of write times exceeded 100,000.	Check if parameters has been used very frequently.	It was changed.	Replace the driver. Change the process to use parameters less frequently after replacement.		

8. TROUBLESHOOTING

Alarm No.: 16		Name: Encoder initial communication error 1			
Alarm content		An error occurred in the communication between an encoder and driver.			
Detail No.	Detail name	Cause	Check method	Check result	Action
16.1	Encoder initial communication - Receive data error 1	(1) An encoder cable is malfunctioning.	Check if the encoder cable is disconnected or shorted.	It has a failure.	Replace or repair the cable.
				It has no failure.	Check (2).
		(4) The driver is malfunctioning.	Replace the driver, and then check the repeatability.	It is not repeatable.	Replace the driver.
				It is repeatable.	Check (5).
		(5) An encoder is malfunctioning.	Replace the servo motor, and then check the repeatability.	It is not repeatable.	Replace the servo motor
				It is repeatable.	Check (6).
(6) Something near the device caused it.	Check the noise, ambient temperature, vibration, etc.	There is a problem in the surrounding.	Take countermeasures against its cause.		
16.2	Encoder initial communication - Receive data error 2	Check it with the check method for [AL. 16.1].			

8. TROUBLESHOOTING

Alarm No.: 16		Name: Encoder initial communication error 1				
Alarm content		□□An error occurred in the communication between an encoder and driver				
Detail No.	Detail name	Cause	Check method	Check result	Action	
16.3	Encoder initial communication - Receive data error 3	(1)	An encoder cable was disconnected.	Check if the encoder cable is connected correctly.	It is not connected	Connect it correctly.
					It is connected.	Check (3).
		(2)	The parameter setting of communication method is incorrect.	Check the parameter setting.	The setting is incorrect.	Set it correctly.
					The setting is correct.	Check (4).
		(3)	An encoder cable is malfunctioning.	Check if the encoder cable is disconnected or shorted.	The setting is incorrect.	Set it correctly.
					The setting is correct.	Check (5).
		(5)	The voltage of the control circuit power supply has been unstable.	Check the voltage of the control circuit power supply.	An instantaneous power failure is occurring at the control circuit power supply.	Review the power and related parts
					It has no failure.	Check (8).
(6)	The driver is malfunctioning.	Replace the driver, and then check the repeatability.	It is not repeatable.	Replace the driver.		
			It is repeatable.	Check (9).		
(7)	An encoder is malfunctioning.	Replace the servo motor, and then check the repeatability.	It is not repeatable.	Replace the servo motor		
			It is repeatable.	Check (10).		
(8)	Something near the device caused it.	Check the noise, ambient temperature, vibration, etc.	There is a problem in the surrounding.	Take countermeasures against its cause.		
16.5	Encoder initial communication - Transmission data error 1	Check it with the check method for [AL. 16.1].				
16.6	Encoder initial communication - Transmission data error 2					
16.7	Encoder initial communication - Transmission data error 3					

8. TROUBLESHOOTING

Alarm No.: 16		Name: Encoder initial communication error 1				
Alarm content		An error occurred in the communication between an encoder and driver.				
Detail No.	Detail name	Cause	Check method	Check result	Action	
16.A	Encoder initial communication - Process error 1	(1)	The driver is malfunctioning.	Replace the driver, and then check the repeatability.	It is not repeatable. It is repeatable.	Replace the driver. Check (2).
		(2)	An encoder is malfunctioning.	Replace the servo motor, and then check the repeatability	It is not repeatable. It is repeatable.	Replace the driver. Check (3).
		(3)	Something near the device caused it.	Check the noise, ambient temperature, vibration, etc.	There is a problem in the surrounding.	Take countermeasures against its cause.
16.B	Encoder initial communication - Process error 2	Check it with the check method for [AL. 16.A].				
16.C	Encoder initial communication - Process error 3					
16.D	Encoder initial communication - Process error 4					
16.E	Encoder initial communication - Process error 5					
16.F	Encoder initial communication - Process error 6					

Alarm No.: 17		Name: Board error				
Alarm content		A part in the driver is malfunctioning.				
Detail No.	Detail name	Cause	Check method	Check result	Action	
17.1	Board error 1	(1)	A current detection circuit is malfunctioning.	Check if the alarm occurs during the servo-on status.	It occurs. It does not occur.	Replace the driver. Check (2).
		(2)	Something near the device caused it.	Check the noise, ambient temperature, etc.	There is a problem in the surrounding.	Take countermeasures against its cause.
17.3	Board error 2	Check it with the check method for [AL. 17.1].				
17.4	Board error 3	(1)	The driver recognition signal was not read properly.	Disconnect the cables except for the control circuit power supply, and then check the repeatability.	It is repeatable. It is not repeatable.	Replace the driver. Check (2).
		(2)	Something near the device caused it.	Check the noise, ambient temperature, etc.	There is a problem in the surrounding.	Take countermeasures against its cause.
17.7	Board error 7	(1)	Check it with the check method for [AL. 17.4].			

8. TROUBLESHOOTING

Alarm No.: 19		Name: Memory error 3 (Flash-ROM)				
Alarm content		□□A part (Flash-ROM) in the driver is failure.				
Detail No.	Detail name	Cause	Check method	Check result	Action	
19.1	Flash-ROM error 1	(1)	The Flash-ROM is malfunctioning.	Disconnect the cables except for the control circuit power supply, and then check the repeatability.	It is repeatable.	Replace the driver.
					It is not repeatable.	Check (2).
		(2)	Something near the device caused it.	Check the noise, ambient temperature, etc.	There is a problem in the surrounding.	Take countermeasures against its cause.
19.2	Flash-ROM error 2	Check it with the check method for [AL. 19.1].				
19.3	Flash-ROM error 3					

Alarm No.: 1A		Name: Servo motor combination error				
Alarm content		• The combination of driver and servo motor is incorrect.				
Detail No.	Detail name	Cause	Check method	Check result	Action	
1A.1	Servo motor combination error 1	(1)	The driver and the servo motor was connected incorrectly.	Check the model name of the servo motor and corresponding driver.	The combination is incorrect.	Use them in the correct combination.
					The combination is correct.	Check (2).
		(2)	The setting of [Pr. PA01] is not corresponding to the connected servo motor.	Check the [Pr. PA01] setting. Rotary servo motor: "0"	The combination is incorrect.	Set [Pr. PA01] correctly. When using a linear servo motor, also check (3).
				The combination is correct.	Check (3).	
		(3)	An encoder is malfunctioning.	Replace the servo motor, and then check the repeatability.	It is not repeatable.	Replace the servo motor
1A.2	Servo motor control mode combination error	(1)	The setting of [Pr. PA01] is not corresponding to the connected servo motor	Check the [Pr. PA01] setting. Rotary servo motor: "0"	The combination is incorrect.	Set [Pr. PA01] correctly.
		(2)	When the fully closed loop control mode is selected, encoders of the servo motor side and the machine side are connected reversely.	Check the connection destination of the encoder.	The connection destination of the encoder is incorrect	Connect it correctly.
1A.4	Servo motor combination error 2	(1)	The driver is malfunctioning.	Replace the driver, and then check the repeatability.	It is not repeatable.	Replace the driver.

Alarm No.: 1B		Name: Converter alarm				
Alarm content		An alarm occurred in the converter unit during the servo-on.				
Detail No.	Detail name	Cause	Check method	Check result	Action	
1B.1	Converter unit error	(1)	The protection coordination cable is not correctly connected	Check the protection coordination cable connection.	It is not connected.	Connect it correctly. It is connected. Check (2).
					It is connected.	Check (2).
		(2)	An alarm occurred in the converter unit during the servo-on.	Check the alarm of the converter unit, and take the action following the remedies for alarms of the converter unit.		

8. TROUBLESHOOTING

Alarm No.: 1E		Name: Encoder initial communication error 2				
Alarm content		· An encoder is malfunctioning.				
Detail No.	Detail name	Cause	Check method	Check result	Action	
1E.1	Encoder malfunction	(1) An encoder is malfunctioning.	Replace the servo motor, and then check the repeatability.	It is not repeatable.	Replace the servo motor.	
		(2) Something near the device caused it.	Check the noise, ambient temperature, vibration, etc.	It is repeatable. There is a problem in the surrounding.	Check (2). Take countermeasures against its cause.	

Alarm No.: 1F		Name: Encoder initial communication error 3				
Alarm content		The connected encoder is not compatible with the driver.				
Detail No.	Detail name	Cause	Check method	Check result	Action	
1F.1	Incompatible encoder	(1) A servo motor encoder, which is not compatible with the driver, was connected.	Check the model of the servo motor encoder.	It is not compatible with the driver.	Replace it with a compatible one.	
				It is compatible with the driver.	Check (2).	
		(2) The software version of the driver does not support the servo motor.	Check if the software version supports the servo motor encoder.	It is not compatible.	Replace the driver to one which software version supports the servo motor encoder	
				It is compatible.	Check (3).	
(3) An encoder is malfunctioning.	Replace the servo motor, and then check the repeatability.	It is not repeatable.	Replace the servo motor.			
		It is repeatable	Replace the driver.			

8. TROUBLESHOOTING

Alarm No.: 20		Name: Encoder normal communication error 1			
Alarm content		An error occurred in the communication between an encoder and driver.			
Detail No.	Detail name	Cause	Check method	Check result	Action
20.1	Encoder normal communication - Receive data error 1	(1) An encoder cable is malfunctioning.	Check if the encoder cable is disconnected or shorted. When you use an A/B/Z-phase differential output linear encoder, check the wiring of the linear encoder.	It has a failure.	Repair or replace the cable.
				It has no failure.	Check (2).
		(2) The external conductor of the encoder cable is not connected to the ground plate of the connector.	Check if it is connected.	It is not connected.	Connect it correctly.
				It is connected.	Check (3).
		(3) The parameter setting of communication method is incorrect. [Pr. PC22]	Check the parameter setting.	The setting is incorrect.	Set it correctly.
				The setting is correct.	Check (4).
		(4) In the parallel drive system, the setting of [Pr. PF40] is incorrect.	Check the parameter setting.	The setting is incorrect.	Set it correctly.
				The setting is correct.	Check (5).
		(5) The driver is malfunctioning.	Replace the driver, and then check the repeatability.	It is not repeatable.	Replace the driver.
				It is repeatable.	Check (6).
		(6) An encoder is malfunctioning.	Replace the servo motor, and then check the repeatability.	It is not repeatable.	Replace the servo motor.
				It is repeatable.	Check (7).
		(7) Something near the device caused it.	Check the noise, ambient temperature, vibration, etc.	There is a problem in the surrounding.	Take countermeasures against its cause.
		20.2	Encoder normal communication - Receive data error 2	Check it with the check method for [AL. 20.1].	
20.3	Encoder normal communication - Receive data error 3				
20.5	Encoder normal communication - Transmission data error 1	(2) An encoder cable is malfunctioning.	Check it with the check method for [AL. 20.1].		
		(3) The external conductor of the encoder cable is not connected to the ground plate of the connector.			
		(5) The driver is malfunctioning.			
		(6) An encoder is malfunctioning.			
		(7) Something near the device caused it.			

8. TROUBLESHOOTING

Alarm No.: 20		Name: Encoder normal communication error 1				
Alarm content		An error occurred in the communication between an encoder and driver.				
Detail No.	Detail name	Cause	Check method	Check result	Action	
20.6	Encoder normal communication - Transmission data error 2	(2) An encoder cable is malfunctioning.	Check it with the check method for [AL. 20.1].			
		(3) The external conductor of the encoder cable is not connected to the ground plate of the connector.				
		(4) When you use an A/B/Z-phase differential output linear encoder, the parameter setting is incorrect.				
		(5) The driver is malfunctioning.				
		(6) An encoder is malfunctioning.				
		(7) Something near the device caused it.				
		20.7				
20.9	Encoder normal communication - Receive data error 4					
20.A	Encoder normal communication - Receive data error 5					

8. TROUBLESHOOTING

Alarm No.: 21		Name: Encoder normal communication error 2				
Alarm content		· The encoder detected an error signal.				
Detail No.	Detail name	Cause	Check method	Check result	Action	
21.1	Encoder data error 1	(1)	The encoder detected a high speed/acceleration rate due to an oscillation or other factors.	Decrease the loop gain, and then check the repeatability.	It is not repeatable.	Use the encoder with low loop gain.
					It is repeatable.	Check (2).
		(2)	The external conductor of the encoder cable is not connected to the ground plate of the connector.	Check if it is connected.	It is not connected.	Connect it correctly.
					It is connected.	Check (3).
		(3)	An encoder is malfunctioning.	Replace the servo motor, and then check the repeatability.	It is not repeatable.	Replace the servo motor.
					It is repeatable.	Check (4).
		(4)	Something near the device caused it.	Check the noise, ambient temperature, vibration, etc.	There is a problem in the surrounding.	Take countermeasures against its cause.
		21.2	Encoder data update error	(1)	An encoder is malfunctioning.	Replace the servo motor, and then check the repeatability.
It is repeatable.	Check (2).					
(2)	The external conductor of the encoder cable is not connected to the ground plate of the connector.			Check if it is connected	It is not connected.	Connect it correctly.
					It is connected.	Check (3).
(3)	Something near the device caused it.			Check the noise, ambient temperature, etc.	There is a problem in the surrounding.	Take countermeasures against its cause
21.3	Encoder data waveform error			Check it with the check method for [AL. 21.2].		
21.4	Encoder nonsignal error	(1)	A signal of the encoder has not been inputted.	Check if the encoder cable is wired correctly	It has a failure.	Review the wiring.
					It has no failure.	Check (2).
		(2)	The external conductor of the encoder cable is not connected to the ground plate of the connector.	Check if it is connected.	It is not connected.	Connect it correctly.
					It is connected.	Check (3).
		(3)	Something near the device caused it.			
21.5	Encoder hardware error 1	Check it with the check method for [AL. 21.2].				
21.6	Encoder hardware error 2					
21.9	Encoder data error 2	Check it with the check method for [AL. 21.1].				

8. TROUBLESHOOTING

Alarm No.: 24		Name: Main circuit error					
Alarm content		<ul style="list-style-type: none"> · A ground fault occurred on the servo motor power lines. · A ground fault occurred at the servo motor. 					
Detail No.	Detail name	Cause		Check method	Check result	Action	
24.1	Ground fault detected by hardware detection circuit	(1)	The driver is malfunctioning.	Disconnect the servo motor power cables (U/V/ W) and check if the alarm occurs.	It occurs.	Replace the driver.	
					It does not occur.	Check (2).	
		(2)	A ground fault or short occurred at the servo motor power cable.	Check if only the servo motor power cable is shorted.	It is shorted.	Replace the servo motor power cable.	
					It is not shorted.	Check (3).	
		(3)	A ground fault occurred at the servo motor.	Disconnect the servo motor power cables on motor side, and check insulation of the motor (between U/V/W/).	It is shorted.	Replace the servo motor.	
					It is not shorted.	Check (4).	
		(4)	The main circuit power supply cable and servo motor power cable were shorted.	Shut off the power, and check if the main circuit power supply cable and servo motor power cable are in contact.	They are in contact.	Correct the wiring.	
					They are not in contact.	Check (5).	
		(5)	Something near the device caused it.	Check the noise, ambient temperature, etc.	There is a problem in the surrounding.	Take countermeasures against its cause.	
		24.2	Ground fault detected by software detection function	(1)	The driver is malfunctioning.	Disconnect the servo motor power cable (U/V/W/), and check if the alarm occurs.	It occurs.
It does not occur.	Check (3).						
(2)	A ground fault or short occurred at the servo motor power cable.			Check if only the servo motor power cable is shorted.	It is shorted.	Replace the servo motor power cable.	
					It is not shorted.	Check (4).	
(3)	A ground fault occurred at the servo motor.			Disconnect the servo motor power cables on motor side, and check insulation between phases (U/V/W/).	It is shorted.	Replace the servo motor.	
					It is not shorted.	Check (5).	
(4)	The main circuit power supply cable and servo motor power cable were shorted.			Shut off the power, and check if the main circuit power supply cable and servo motor power cable are in contact.	They are in contact.	Correct the wiring.	
					They are not in contact.	Check (6).	
(5)	Something near the device caused it.			Check the noise, ambient temperature, etc.	There is a problem in the surrounding.		

8. TROUBLESHOOTING

Alarm No.: 25		Name: Absolute position erased				
Alarm content		<ul style="list-style-type: none"> • The absolute position data is faulty. • Power was switched on for the first time in the absolute position detection system. • After the scale measurement encoder was set to the absolute position detection system, the power was switched on for the first time. 				
Detail No.	Detail name	Cause	Check method	Check result	Action	
25.1	Servo motor encoder - Absolute position erased	(1)	Power was switched on for the first time in the absolute position detection system.	Check if this is the first time you switched on the power in the absolute position detection system.	This is the first time. Check that the battery is mounted correctly, and make home position return.	
					This is not the first time. Check (2).	
		(2)	1) When a battery Battery case was used, CN4 of the driver was disconnected during control circuit power supply off.	Check if the battery was removed in this way when the control circuit power supply was off.	It was removed. Check that the battery is mounted correctly, and make home position return.	
		(6)	The battery voltage is low. The battery is consumed.	Check the battery voltage with a tester.	It is less than 3 V DC. Replace the battery. It is 3 V DC or more. Check (7).	
		(7)	The voltage has dropped greatly in the encoder cable wired to the battery.	Check if a recommended cable is used for the encoder cable.	It is not used. Use a recommended wire. It is used. Check (8).	
		(8)	A battery cable is malfunctioning.	Check for the loose connection with a tester.	It has a failure. Replace the battery cable. It has no failure. Check (9).	
		(9)	There is a loose connection of the encoder cable on the servo motor side.	Check for the loose connection with a tester. Measure the voltage on the servo motor side.	It has a failure. Repair or replace the encoder cable. It has no failure. Check (10).	
		(11)	The driver is malfunctioning.	Replace the driver, and then check the repeatability.	It is not repeatable. Replace the driver. It is repeatable. Check (12).	
		(12)	An encoder is malfunctioning.	Replace the servo motor, and then check the repeatability.	It is not repeatable. Replace the servo motor	

8. TROUBLESHOOTING

Alarm No.: 2B		Name: Encoder counter error				
Alarm content		Data which encoder created is failure.				
Detail No.	Detail name	Cause	Check method	Check result	Action	
2B.1	Encoder counter error 1	(1)	An encoder cable is malfunctioning.	Check if the encoder cable is disconnected or shorted.	It has a failure.	Repair or replace the cable.
					It has no failure.	Check (2).
		(2)	The external conductor of the encoder cable is not connected to the ground plate of the connector.	Check if it is connected.	It is not connected.	Connect it correctly.
					It is connected.	Check (3).
		(3)	Something near the device caused it.	Check the noise, ambient temperature, vibration, etc.	There is a problem in the surrounding.	Take countermeasures against its cause.
There is no problem in the surrounding.	Check (4).					
(4)	An encoder is malfunctioning.	Replace the direct drive motor, and then check the repeatability.	It is not repeatable. Replace	Replace the direct drive motor.		
2B.2	Encoder counter error 2	Check it with the check method for [AL. 2B.1].				

Alarm No.: 30		Name: Regenerative error				
Alarm content		<ul style="list-style-type: none"> • Permissible regenerative power of the built-in regenerative resistor or regenerative option is exceeded. • A regenerative transistor in the driver is malfunctioning. 				
Detail No.	Detail name	Cause	Check method	Check result	Action	
30.1	Regeneration heat error	(1)	The setting of the regenerative resistor (regenerative option) is incorrect.	Check the regenerative resistor (regenerative option) and [Pr. PA02] setting.	The setting value is incorrect.	Set it correctly.
					It is set correctly.	Check (2).
		(2)	The regenerative resistor (regenerative option) is not connected.	Check if the regenerative resistor (regenerative option) is connected correctly.	It is not connected correctly.	Connect it correctly
					It is connected correctly.	Check (3).
		(3)	The combination of regenerative resistor (regenerative option) and driver is incorrect.	Check if the regenerative resistor (regenerative option) and the driver are connected in the specified combination.	The combination is incorrect.	Use them in the correct combination.
					The combination is correct.	Check (4).
		(4)	The power supply voltage is high.	Check if the voltage of the input power supply is over the prescribed value. 264 V AC	It is higher than the prescribed value.	Reduce the power supply voltage.
					It is at the prescribed value or lower.	Check (5).

8. TROUBLESHOOTING

		(5)	The regenerative load ratio exceeded 100%.	Check the regenerative load ratio when alarm occurs.	It is 100% or more	Reduce the frequency of positioning. Increase the deceleration time constant. Reduce the load. Use a regenerative option if it is not being used. Review the regenerative option capacity.
30.2	Regeneration signal error	(1)	A detection circuit of the driver is malfunctioning.	Check if the regenerative resistor (regenerative option) is overheating.	It is overheating abnormally.	Replace the driver.
30.3	Regeneration feedback signal error	(1)	A detection circuit of the driver is malfunctioning.	Remove the regenerative option or built-in regenerative resistor, and then check if the alarm occurs at power on.	The alarm occurs.	Replace the driver.
					The alarm does not occur.	Check (2).
		(2)	Something near the device caused it.	Check the noise, ground fault, ambient temperature, etc.	There is a problem in the surrounding.	Take countermeasures against its cause.

Alarm No.: 31		Name: Overspeed				
Alarm content		•The servo motor speed has exceeded the instantaneous permissible speed.				
Detail No.	Detail name	Cause	Check method	Check result	Action	
31.1	Abnormal motor speed	(1)	The command pulse frequency is high.	Check the command pulse frequency.	The command pulse frequency is high.	Check operation pattern.
					The command pulse frequency is low.	Check (2).
		(2)	The settings of the electronic gear are incorrect.	Check the setting value of the electronic gear.	The setting value is incorrect.	Review the settings.
					The setting value is correct.	Check (5).
		(3)	The servo motor was at the maximum torque (maximum thrust) at the time of acceleration.	Check if the torque (thrust) at the time of acceleration is the maximum torque (maximum thrust).	It is the maximum torque (maximum thrust).	Increase the acceleration/deceleration time constant. Or reduce the load.
					It is less than the [GF] maximum torque (maximum thrust).	Check (6).
		(4)	The servo system is unstable and oscillating.	Check if the servo motor is oscillating.	It is oscillating.	Adjust the servo gain. Or reduce the load.
					It is not oscillating.	Check (7).
(5)	The velocity waveform has overshoot.	Check if it is overshooting because the acceleration time constant is too short.	It is overshooting.	Increase the acceleration/deceleration time constant.		
			It is not overshooting.	Check (8).		
(7)	The connection of the servo motor is incorrect.	Check the wiring of U/V/W.	It is incorrect.	Set it correctly.		
			It is correct.	Check (11).		
(8)	The encoder or linear encoder is malfunctioning.	Check if the alarm is occurring during less than instantaneous permissible speed.	It is occurring during less than instantaneous permissible speed.	Replace the servo motor.		

8. TROUBLESHOOTING

Alarm No.: 32		Name: Overcurrent					
Alarm content		· A current higher than the permissible current was applied to the driver.					
Detail No.	Detail name	Cause	Check method	Check result	Action		
32.1	Overcurrent detected at hardware detection circuit (during operation)	(1)	The driver is malfunctioning.	Disconnect the servo motor power cables (U/V/W) and check if the alarm occurs.	It occurs.	Replace the driver.	
					It does not occur.	Check (2).	
		(2)	A ground fault or short occurred at the servo motor power cable.	Check if only the servo motor power cable is shorted.	It is shorted.	Replace the servo motor power cable.	
					It is not shorted.	Check (3).	
		(3)	The servo motor is malfunctioning.	Disconnect the servo motor power cables on motor side, and check insulation of the motor (between U/V/W/ ⊕/—)	A ground fault is occurring.	Replace the servo motor.	
					A ground fault is not occurring.	Check (4).	
		(4)	The dynamic brake is malfunctioning.	Check if the alarm occurs when you turn on the servo-on command.	It occurs.	Replace the driver.	
					It does not occur.	Check (7).	
		(5)	Something near the device caused it.	Check the noise, ambient temperature, etc.	There is a problem in the surrounding.	Take countermeasures against its cause.	
					There is no problem in the surrounding	Check it with the check method for [AL. 45.1].	

Alarm No.: 32		Name: Overcurrent					
Alarm content		· A current higher than the permissible current was applied to the driver.					
Detail No.	Detail name	Cause	Check method	Check result	Action		
32.2	Overcurrent detected at software detection function (during operation)	(1)	The servo gain is high.	Check if an oscillation is occurring.	An oscillation is occurring.	Reduce the speed loop gain ([Pr. PB09]).	
					An oscillation is not occurring.	Check (2).	
		(2)	The driver is malfunctioning.	Disconnect the servo motor power cables (U/V/W) and check if the alarm occurs.	It occurs.	Replace the driver.	
					It does not occur.	Check (3).	
		(3)	A ground fault or short occurred at the servo motor power cable.	Check if only the servo motor power cable is shorted.	It is shorted.	Replace the servo motor power cable.	
					It is not shorted.	Check (4).	
		(4)	The servo motor is malfunctioning.	Disconnect the servo motor power cables on motor side, and check insulation of the motor (between U/V/W/ /).	A ground fault is occurring.	Replace the servo motor.	
					A ground fault is not occurring.	Check (5).	
		(5)	Something near the device caused it.	Check the noise, ambient temperature, etc.	There is a problem in the surrounding.	Take countermeasures against its cause.	
		32.3	Overcurrent detected at hardware detection circuit (during a stop)	Check it with the check method for [AL. 32.1].			
32.4	Overcurrent detected at software detection function (during a stop)	Check it with the check method for [AL. 32.2].					

8. TROUBLESHOOTING

Alarm No.: 33		Name: Overvoltage				
Alarm content		•The value of the bus voltage exceeded the prescribed value.				
Detail No.	Detail name	Cause	Check method	Check result	Action	
33.1	Main circuit voltage error	(1)	The setting of the regenerative resistor (regenerative option) is incorrect.	Check the regenerative resistor (regenerative option) and [Pr. PA02] setting.	The setting value is incorrect.	Set it correctly.
					It is set correctly.	Check (2).
		(2)	The regenerative resistor (regenerative option) is not connected.	Check if the regenerative resistor (regenerative option) is connected correctly.	It is not connected correctly.	Connect it correctly.
					It is connected correctly.	Check (3).
		(3)	Wire breakage of builtin regenerative resistor or regenerative option	Measure the resistance of the built-in regenerative resistor or regenerative option.	The resistance is abnormal.	When using a built-in regenerative resistor, replace the driver. When using a regenerative option, replace the regenerative option.
					The resistance is normal.	Check (4).
		(4)	The regeneration capacity is insufficient.	Set a longer deceleration time constant, and then check the repeatability.	It is not repeatable.	When using a built-in regenerative resistor, use a regenerative option. When using a regenerative option, use a larger capacity one.
					It is repeatable.	Check (5).
		(5)	Power supply voltage high.	Check if the voltage of the input power supply is over the prescribed value. 264 V AC	It is higher than the prescribed value.	Reduce the power supply voltage.
					It is at the prescribed value or lower.	Check (6).
(6)	Something near the device caused it.	Check the noise, ambient temperature, etc.	There is a problem in the surrounding.	Take countermeasures against its cause.		

Alarm No.: 35		Name: Command frequency error				
Alarm content		Input pulse frequency of command pulse is too high.				
Detail No.	Detail name	Cause	Check method	Check result	Action	
35.1	Command frequency error	(1)	The command pulse frequency is high.	Check the command pulse frequency.	The command pulse frequency is high.	Check operation pattern.
					The command pulse frequency is low.	Check (2).
		(2)	The setting of "Command input pulse train filter selection" in [Pr. PA13] is not correct.	Check if the command pulse frequency is within the setting range of the filter.	It is out of setting range.	Review the filter setting.
					It is within the setting range.	Check (6).
		(3)	Inputted frequency with a manual pulse generator is high.	Check the inputted frequency of the manual pulse generator	The command pulse frequency is high.	Reduce the inputted frequency of the manual pulse generator.
					The command pulse frequency is low.	Check (6).
		(4)	Something near the device caused it.	Check the noise, ambient temperature, etc.	There is a problem in the surrounding.	Take ountermeasures against its cause.

8. TROUBLESHOOTING

Alarm No.: 37		Name: Parameter error				
Alarm content		<ul style="list-style-type: none"> •Parameter setting is incorrect. •Point table setting is incorrect. 				
Detail No.	Detail name	Cause	Check method	Check result	Action	
37.1	Parameter setting range error	(1)	A parameter was set out of setting range.	Check the parameter error No. and setting value.	It is out of setting range.	Check operation pattern.
					It is within the setting range.	Check (2).
		(2)	A parameter setting contradicts another.	Check the parameter error No. and setting value.	A setting value is incorrect.	Review the filter setting.
					A setting value is correct.	Check (6).
		(3)	The parameter setting has changed due to a driver malfunction.	Replace the driver, and then check the repeatability.	It is not repeatable.	Replace the driver.
37.2	Parameter combination error	(1)	A parameter setting contradicts another.	Check the parameter error No. and setting value.	A setting value is incorrect.	Correct the setting value. (When the master-slave function is set, also check (2).)
37.3	Point table setting error	(1)	The setting of point tables is incorrect.	Check if the setting of point tables is within the setting range. Check the parameter error No. and point table error No. with the point table error No. display on the display of the driver. Or check the setting value with the point table display of setup software (MR Configurator2™).	A setting value is incorrect.	Correct the setting value.
					A setting value is correct.	Check (2).
		(2)	A point table setting has changed due to a driver malfunction.	Replace the driver, and then check the repeatability.	It is not repeatable.	Replace the driver.

8. TROUBLESHOOTING

Alarm No.: 39		Name: Program error				
Alarm content		A program used for the program operation is incorrect.				
Detail No..	Detail name	Cause	Check method	Check result	Action	
39.1	Program error	(1) A checksum of the program did not match at power-on. (The program has an error.)	Check if an error occurred (such as entered noise, power-off) at program write.	It has a failure.	Rewrite the program.	
				It has no failure.	Check (2).	
		(2) A program has changed due to a driver malfunction.	Replace the driver, and then check the repeatability.	It is not repeatable.	Replace the driver.	
39.2	Instruction argument external error	(1) A program has never been written since program initialization.	Check if a program was written.	It was not executed.	Write the program.	
				It was executed.	Check (3).	
		(2) A command argument is using a value out of specifications.	Check if the command description has a failure.	It has a failure.	Correct the command description.	
		It has no failure.	Check (3).			
		(3) A program has changed due to a driver malfunction.	Replace the driver, and then check the repeatability.	It is not repeatable.	Replace the driver.	
39.3	Register No. error	(1) A specified number of the general purpose register used for a command is a value out of specifications.	Check if the command description has a failure.	It has a failure.	Correct the command description.	
				It has no failure.	Check (2).	
		(2) A program has changed due to a driver malfunction.	Replace the driver, and then check the repeatability.	It is not repeatable.	Replace the driver.	
39.4	Noncorrespondence instruction error	(1) A used command is not correspondent to the program.	Check if the command description has a failure.	It has a failure.	Correct the command description.	
				It has no failure.	Check (2).	
		(2) A program has changed due to a driver malfunction.	Replace the driver, and then check the repeatability.	It has no failure.	Replace the driver.	

Alarm No.: 3A		Name: Inrush current suppression circuit error				
Alarm content		<input type="checkbox"/> <input type="checkbox"/> The inrush current suppression circuit error was detected.				
Detail No.	Detail name	Cause	Check method	Check result	Action	
3A.1	Inrush current suppression circuit error	(1) Inrush current suppressor circuit is malfunctioning.	Replace the driver, and then check the repeatability.	It is not repeatable.	Replace the driver.	

Alarm content		Name: Operation mode error				
Alarm content		· The operation mode setting was changed.				
Detail No.	Detail name	Cause	Check method	Check result	Action	
3E.6	Operation mode switch error	(1) A method of positioning data memorized in the driver (point table method/program method) is different from the actual positioning mode (point table method/program method).	Check if the positioning mode (point table method/program method) was changed. Positioning mode: [Pr. PA01] " _ _ _ x"	It was changed. (with a purpose)	After changing the positioning mode, initialize the point table method/ program method. (Refer to section 7.2.8 [Pr. PT34] of "MRJ4-A_-RJ driver Instruction Manual (Positioning Mode)")	
				After changing the positioning mode, initialize		
				It was changed by mistake.	Set the positioning mode back to the correct setting.	

8. TROUBLESHOOTING

Alarm No.: 45		Name: Main circuit device overheat				
Alarm content		· Inside of the driver overheated.				
Detail No.	Detail name	Cause	Check method	Check result	Action	
45.1	Main circuit device overheat error 1	(1)	Ambient temperature has exceeded 55 °C. .	Check the ambient temperature.	It is over 55 °C.	Lower the ambient temperature.
					It is less than 55°C.	Check (2).
		(2)	The close mounting is out of specifications.	Check the specifications of close mounting.	It is out of specifications.	Use within the range of specifications.
					It is within specifications.	Check (3).
		(3)	Turning on and off were repeated under the overload status.	Check if the overload status occurred many times.	It occurred.	Check operation pattern.
					It did not occur.	Check (4).
(4)	A cooling fan, heat sink, or openings is clogged with foreign matter.	Clean the cooling fan, heat sink, or openings, and then check the repeatability.	It is not repeatable.	Clean it periodically.		
			It is repeatable.	Check (5).		
(5)	The driver is malfunctioning.	Replace the driver, and then check the repeatability.	It is not repeatable.	Replace the driver.		
45.2	Main circuit device overheat error 2	(1)	Check it with the check method for [AL. 45.1].			

8. TROUBLESHOOTING

Alarm No.: 46		Name: Servo motor overheat			
Alarm content		• The servo motor overheated.			
Detail No.	Detail name	Cause	Check method	Check result	Action
46.1	Abnormal temperature of servo motor 1	(1) Ambient temperature of the servo motor has exceeded 40°C.	Check the ambient temperature of the servomotor.	It is over 40°C	Lower the ambient temperature.
				It is less than 40 °C	Check (2).
		(2) Servo motor is overloaded.	Check the effective load ratio.	The effective load ratio is high.	Reduce the load or review the operation pattern.
				The effective load ratio is small.	Check (3).
		(3) The thermal sensor in the encoder is malfunctioning.	Check the servo motor temperature when the alarm occurs.	The servo motor temperature is low.	Replace the servo motor.
46.3	Thermistor disconnected error	(1) In the parallel drive system, the parameter settings and the axis number settings are incorrect.	Check the settings of [Pr.PF37 Parallel drive -Encoder ID setting 1]. Check if the setting of [Pr. PF40 Parallel drive -Servo motor side system setting] matches the setting of the axis number set with the combination of SW2-3, SW2-4, and SW1.	It is not set correctly.	Set the parameter and the axis number correctly.
				It is set correctly.	Check (2).
		(2) In the parallel drive system, the encoder cable from the servo motor is not connected to the encoder master driver.	Check if the encoder cable from the servo motor is connected to the encoder master driver.	It is not connected.	Connect the encoder cable of the servo motor to the encoder master driver. Connect the encoder master driver and the encoder slave driver in the order of the axis number.
				It is connected.	Check (3).
		(3) A thermistor wire is not connected.	Check the thermistor wire.	It is not connected.	Connect it correctly.
				It is connected.	Check (4).
(5) The thermistor wire is disconnected.	Check the thermistor wire.	It is disconnected.	Repair the lead wire.		
		It is not disconnected.	Replace the servo motor.		
46.4	Thermistor circuit error	(1) A thermistor circuit of the driver is malfunctioning.	Replace the driver, and then check the repeatability	It is not repeatable.	Replace the driver.
46.5	Abnormal temperature of servo motor 3	Check it with the check method for [AL. 46.1].			
46.6	Abnormal temperature of servo motor 4	(1) A current was applied to the driver in excess of its continuous output current.	Check the effective load ratio.	The effective load ratio is high.	Reduce the load or review the operation pattern. Or use a larger capacity motor.

8. TROUBLESHOOTING

Alarm No.: 47		Name: Cooling fan error			
Alarm content		<ul style="list-style-type: none"> • The speed of the driver cooling fan decreased. • Or the fan speed decreased to the alarm occurrence level or less. 			
Detail No.	Detail name	Cause	Check method	Check result	Action
47.1	Cooling fan stop error	(1) Foreign matter was caught in the cooling fan.	Check if a foreign matter is caught in the cooling fan.	Something has been caught.	Remove the foreign matter.
				Nothing has been caught.	Check (2).
		(2) Cooling fan life expired.	Check if the cooling fan is stopping.	It is stopping.	Replace the driver.
47.2	Cooling fan speed reduction error	(1) Foreign matter was caught in the cooling fan.	Check if a foreign matter is caught in the cooling fan.	Something has been caught.	Remove the foreign matter.
				Nothing has been caught.	Check (2).
		(2) Cooling fan life expired.	Check the cooling fan speed.	The fan speed is less than the alarm occurrence level.	Replace the driver.

Alarm No.: 50		Name: Overload 1			
Alarm content		Load exceeded overload protection characteristic of driver.			
Detail No.	Detail name	Cause	Check method	Check result	Action
50.1	Thermal overload error 1 during operation	(1) The servo motor power cable was disconnected.	Check the servo motor power cable.	It is disconnected.	Repair or replace the servo motor power cable.
				It is not isconnected.	Check (2).
		(2) The connection of the servo motor is incorrect.	Check the wiring of U/V/ W.	It is incorrect.	Connect it correctly.
				It is correct.	Check (3).
		(3) The electromagnetic brake has not released. (The electromagnetic brake has been activated.)	Check if the electromagnetic brake is released during operation.	It is not released.	Release the electromagnetic brake.
				It is released.	Check (4).
		(5) A current was applied to the driver in excess of its continuous output current.	Check the effective load ratio.	The effective load ratio is high.	Reduce the load. Or use a larger capacity motor.
				The effective load ratio is small.	Check (6).
(6) The servo system is unstable and resonating.	Check if it is resonating	It is resonating.	Adjust gains.		
		It is not resonating.	Check (8).		
(7) The driver is malfunctioning.	Replace the driver, and then check the repeatability.	It is not repeatable.	Replace the driver.		
		It is repeatable.	Check (9).		
(8) The encoder is malfunctioning.	Replace the servo motor encoder, and then check the repeatability.	It is not repeatable.	Replace the servo motor encoder.		
50.2	Thermal overload error 2 during operation	Check it with the check method for [AL. 50.1].			
50.3	Thermal overload error 4 during operation				

8. TROUBLESHOOTING

Alarm No.: 50		Name: Overload 1				
Alarm content		· Load exceeded overload protection characteristic of driver.				
Detail No.	Detail name	Cause	Check method	Check result	Action	
50.4	Thermal overload error 1 during a stop	(1)	A moving part collided against the machine.	Check if it collided.	It collided.	Check operation pattern.
					It did not collide.	Check (2).
		(2)	The servo motor power cable was disconnected.	Check the servo motor power cable.	It is disconnected.	Repair or replace the servo motor power cable.
					It is not disconnected.	Check (3).
		(3)	Hunting occurs during servo-lock.	Check if the hunting is occurring.	The hunting is occurring.	Adjust gains.
					The hunting is not occurring.	Check (4).
		(4)	The electromagnetic brake has not released. (The electromagnetic brake has been activated.)	Check if the electromagnetic brake is released.	It is not released.	Release the electromagnetic brake.
					It is released.	Check (5).
		(6)	A current was applied to the driver in excess of its continuous output current.	Check the effective load ratio.	The effective load ratio is high.	Reduce the load. Or use a larger capacity motor.
					The effective load ratio is small.	Check (7).
		(7)	The servo system is unstable and resonating.	Check if it is resonating.	It is resonating.	Adjust gains.
					It is not resonating.	Check (9).
(8)	The driver is malfunctioning.	Replace the driver, and then check the repeatability.	It is not repeatable.	Replace the driver.		
			It is repeatable.	Check (10).		
(9)	The encoder, servo motor, is malfunctioning.	Replace the servo motor, and then check the repeatability.	It is not repeatable.	Replace the servo motor.		
50.5	Thermal overload error 2 during a stop	Check it with the check method for [AL. 50.4].				
50.6	Thermal overload error 4 during a stop					

8. TROUBLESHOOTING

Alarm No.: 51		Name: Overload 2			
Alarm content		· Maximum output current flowed continuously due to machine collision or the like.			
表示	Detail name	Cause	Check method	Action	Action
51.1	Thermal overload error 3 during operation	(1) The servo motor power cable was disconnected.	Check the servo motor power cable.	It is disconnected.	Repair or replace the servo motor power cable.
				It is not disconnected.	Check (2).
		(2) The connection of the servo motor is incorrect.	Check the wiring of U/V/W.	It is incorrect.	Connect it correctly.
				It is correct.	(Check (3)).
		(3) The connection of the encoder cable is incorrect.	Check if the encoder cable is connected correctly.	It is incorrect.	Connect it correctly.
				It is correct.	Check (4).
		(5) The torque is insufficient.	Check the peak load ratio.	The torque is saturated.	Reduce the load or review the operation pattern. Or use a larger capacity motor.
				The torque is not [GF] saturated.	Check (6).
				(6) The driver is malfunctioning.	Replace the driver, and then check the repeatability.
		It is repeatable.	Check (7).		
(7) An encoder or servo motor is malfunctioning.	Replace the servo motor, and then check the repeatability.	It is not repeatable.	Replace the servo motor.		
51.2	Thermal overload error 3 during a stop	(1) A moving part collided against the machine.	Check if it collided.	It collided.	Check operation pattern.
				It did not collide.	Refer to (2).
		(2) The servo motor power cable was disconnected.	Check it with the check method for [AL. 51.1].		
		(3) The connection of the servo motor is incorrect.			
		(4) The connection of the encoder cable is incorrect.			
		(6) The torque is saturated.			
		(7) The driver is malfunctioning			
		(8) An encoder is malfunctioning.			

8. TROUBLESHOOTING

Alarm No.: 52		Name: Error excessive				
Alarm content		· Droop pulses have exceeded the alarm occurrence level.				
Detail No.	Detail name	Cause	Check method	Check result	Action	
52.1	Excess droop pulse 1	(1)	The servo motor power cable was disconnected.	Check the servo motor power cable.	It is disconnected.	Repair or replace the servo motor power cable.
					It is not disconnected.	Check (2).
		(2)	The connection of the servo motor is incorrect.	Check the wiring of U/V/W.	It is incorrect.	Connect it correctly.
					It is correct.	Check (3).
		(3)	The connection of the encoder cable is incorrect.	Check if the encoder cable is connected correctly.	It is incorrect.	Connect it correctly.
					It is correct.	Check (4).
		(4)	The torque limit has been enabled.	Check if the limiting torque is in progress.	The limiting torque is in progress.	Increase the torque limit value.
					The limiting torque is not in progress.	Check (5).
		(5)	A moving part collided against the machine.	Check if it collided.	It collided.	Check operation pattern.
					It did not collide.	Check (6).
		(6)	The electromagnetic brake has not released. (The electromagnetic brake has been activated.)	Check if electromagnetic brake is released.	It is not released.	Release the electromagnetic brake.
					It is released.	Check (7).
		(7)	The torque is insufficient.	Check the peak load ratio.	The torque is saturated.	Reduce the load or review the operation pattern. Or use a larger capacity motor.
					The torque is not saturated.	Check (8).
(8)	Power supply voltage dropped.	Check the bus voltage value.	The bus voltage is low.	Check the power supply voltage and power supply capacity.		
			The bus voltage is high.	Check (9).		
(9)	Acceleration/ deceleration time constant is too short.	Set a longer deceleration time constant, and then check the repeatability	It is not repeatable.	Increase the acceleration/deceleration time constant.		
			It is repeatable.	Check (10).		
(10)	The position loop gain is small.	Increase the position loop gain, and then check the repeatability.	It is not repeatable.	Increase the position loop gain ([Pr. PB08]).		
			It is repeatable.	Check (11).		
(11)	The error excessive alarm level was not set correctly.	Check the setting of the error excessive alarm level. [Pr. PC24], [Pr.PC43]	It is not set correctly.	Set it correctly.		
			It is set correctly.	Check (12).		
(12)	Servo motor shaft was rotated by external force.	Measure the actual position under the servolock status.	It is rotated by external force./ It was moved by external force.	Review the machine.		
			It is not rotated by external force./ It was not moved by external force.	Check (13).		
(13)	Servo-on was enabled while the servo motor was rotating.	Measure the actual position at servo-on.	Servo is enabled while the servo motor is rotating. Servo-on is enabled while the linear servo motor is moving.	Review the timing of the servo-on.		
			Servo-on is not enabled while the servo motor is	Check (14).		

8. TROUBLESHOOTING

				rotating Servo-on is not enabled while the linear servo motor is moving.			
		(14)	The encoder or the servo motor is malfunctioning.	Replace the servo motor, and then check the repeatability.	It is not repeatable. It is repeatable.	Replace the servo motor. Check (15).	
		(15)	The driver is malfunctioning.	Replace the driver, and then check the repeatability.	It is not repeatable.	Replace the driver.	
52.3	Excess droop pulse 2	Check it with the check method for [AL. 52.1].					
52.4	Error excessive during 0 torque limit	(1)	The torque limit has been 0.	Check the torque limit value.	The torque limit has been 0.	Do not input a command while the torque limit value is 0.	
52.5	Excess droop pulse 3	Check it with the check method for [AL. 52.1].					

Alarm No.: 54		Name: Oscillation detection				
Alarm content		· An oscillation of the servo motor was detected.				
Detail No.	Detail name	Cause	Check method	Check result	Action	
54.1	Oscillation detection error	(1)	The servo system is unstable and oscillating.	Check if the servo motor is oscillating. Check the torque ripple with setup software (MR Configurator2™).	The torque ripple is vibrating.	Adjust the servo gain with the auto tuning. Set the machine resonance suppression filter.
					The torque ripple is not vibrating.	Check (2).
		(2)	The resonance frequency has changed due to deterioration.	Measure the resonance frequency of the equipment and compare it with the setting value of the machine resonance suppression filter.	The resonance frequency of the equipment is different from the filter setting value.	Change the setting value of the machine resonance suppression filter.
					The resonance frequency of the equipment is the same as the filter setting value.	Check (3).
(3)	The encoder is malfunctioning.	Replace the servo motor, and then check the repeatability.	It is not repeatable.	Replace the servo motor.		

Alarm No.: 56		Name: Forced stop error				
Alarm content		· The servo motor does not decelerate normally during forced stop deceleration.				
Detail No.	Detail name	Cause	Check method	Check result	Action	
56.2	Over speed during forced stop	(1)	The forced stop deceleration time constant is short. [Pr. PC24]	Increase the parameter setting value, and then check the repeatability.	It is not repeatable.	Adjust the deceleration time constant.
					It is repeatable.	Check (2).
		(2)	The torque limit has been enabled.	Check if the limiting torque is in progress.	The limiting torque is in progress.	Review the torque limit value.
					The limiting torque is not in progress.	Check (3).
		(3)	The servo system is unstable and oscillating.	Check if the servo motor is oscillating. Check the torque ripple with setup software (MR Configurator2™).	The torque ripple is vibrating.	Adjust the servo gain. Set the machine resonance suppression filter.
The torque ripple is not vibrating.	Check (4).					
(4)	The encoder is malfunctioning.	Replace the servo motor, and then check the repeatability.	It is not repeatable.	Replace the servo motor.		
56.3	Estimated	(1)	The forced stop	Increase the parameter	It is not repeatable.	Adjust the deceleration

8. TROUBLESHOOTING

	distance over during forced stop		deceleration time constant is short. [Pr. PC24]	setting value, and then check the repeatability.	It is repeatable.	time constant. Check (2).
		(2)	The torque limit has been enabled.	Check if the limiting torque is in progress.	The limiting torque is in progress.	Review the torque limit value.
		(3)	The encoder or linear encoder is malfunctioning.	Replace the servo motor, and then check the repeatability.	The limiting torque is not in progress.	Check (3).
					It is not repeatable.	Replace the servo motor.

Alarm No.: 61		Name: Operation error				
Alarm content		· An operation of the positioning function failed.				
Detail No.	Detail name	Cause	Check method	Check result	Action	
61.1	Point table setting range error	(1) "1" or "3" was set to the sub function of the last point table (255).	Check if "1" or "3" was set.	It was set.	Review the settings.	

Alarm No.: 63		Name: STO timing error				
Alarm content		· STO input signal turns off while the servo motor is rotating.				
Detail No.	Detail name	Cause	Check method	Check result	Action	
63.1	STO1 off	(1) STO1 was turned off (enabled) under the following speed conditions. 1) Servo motor speed: 50 r/min or more	Check if STO1 is off (enabled).	It is off (enabled).	Turn on STO1 (disabled).	
63.2	STO2 off	(1) STO2 was turned off (enabled) under the following speed conditions.	Check if STO2 is off (enabled).	It is off (enabled).	Turn on STO2 (disabled).	

Alarm No.: 63		Name: STO timing error				
Alarm content		· STO input signal turns off while the servo motor is rotating.				
Detail No.	Detail name	Cause	Check method	Check result	Action	
63.2	STO2 off	(1) Servo motor speed: 50 r/min or more				
63.5	STO by functional safety unit	STO of the functional safety unit was turned off (enabled) under the following speed conditions. 1) Servo motor speed: 50 r/min or more	Check if STO of the functional safety unit is off (enabled).	It is off (enabled).	Turn on STO (disabled).	

Alarm No.: 64		Name: Functional safety unit setting error				
Alarm content		· A setting of the driver or functional safety unit was incorrect.				
Detail No.	Detail name	Cause	Check method	Check result	Action	
64.1	STO input error	(1) When a functional safety unit is used, a connector is connected to CN8 of the driver.	Check the connection of the CN8 connector.	It is connected.	Turn off the control circuit power supply of the driver, and then remove the connector of CN8.	

8. TROUBLESHOOTING

Alarm No.: 65		Name: Functional safety unit connection error				
Alarm content		• Communication or signal between a functional safety unit and driver failed.				
Detail No.	Detail name	Cause	Check method	Check result	Action	
65.1	Functional safety unit communication error 1	(1)	The functional safety unit came off.	Check the installation of the functional safety unit.	It is disconnected.	Turn off the control circuit power supply of the driver, and then connect the functional
					It is connected.	Check (2).
		(2)	The functional safety unit is malfunctioning.	Replace the functional safety unit, and then check the repeatability.	It is not repeatable.	Replace the functional safety unit.
					It is repeatable.	Check (3).
		(3)	The driver is malfunctioning.	Replace the driver, and then check the repeatability.	It is not repeatable.	Replace the driver.
					It is repeatable.	Check (4).
		(4)	Something near the device caused it.	Check the noise, ambient temperature, etc.	There is a problem in the surrounding.	Take countermeasures against its cause.
		65.2	Functional safety unit communication error 2	Check it with the check method for [AL. 65.1].		
65.3	Functional safety unit communication error 3					
65.4	Functional safety unit communication error 4					
65.5	Functional safety unit communication error 5					
65.6	Functional safety unit communication error 6					
65.7	Functional safety unit communication error 7					
65.8	Functional safety unit shutoff					
65.9	Functional safety unit shutoff					

8. TROUBLESHOOTING

Alarm No.: 66		Name: Encoder initial communication error (safety observation function)				
Alarm content		<ul style="list-style-type: none"> •The connected encoder is not compatible with the driver. •An error has occurred in the communication between an encoder and driver. 				
Detail No.	Detail name	Cause	Check method	Check result	Action	
66.1	Encoder initial communication - Receive data error 1 (safety observation function)	(1)	An encoder cable is malfunctioning.	Check if the encoder cable is disconnected or shorted.	It has a failure.	Replace or repair the cable.
				It has no failure.	Check (2).	
		(2)	The driver is malfunctioning.	Replace the driver, and then check the repeatability.	It is not repeatable.	Replace the driver.
				It is repeatable.	Check (3).	
		(3)	An encoder is malfunctioning.	Replace the servo motor, and then check the repeatability.	It is not repeatable.	Replace the servo motor.
				It is repeatable.	Check (4).	
		(4)	Something near the device caused it.	Check the noise, ambient temperature, vibration, etc.	There is a problem in the surrounding.	Take countermeasures against its cause.
66.2	Encoder initial communication - Receive data error 2 (safety observation function)	Check it with the check method for [AL. 66.1].				
66.3	Encoder initial communication - Receive data error 3 (safety observation function)					
66.7	Encoder initial communication - Transmission data error 1 (safety observation function)					

Alarm No.: 66		Name: Encoder initial communication error (safety observation function)				
Alarm content		<ul style="list-style-type: none"> • The connected encoder is not compatible with the driver. • An error has occurred in the communication between an encoder and driver 				
Detail No.	Detail name	Cause	Check method	Check result	Action	
66.9	Encoder initial communication - Process error 1 (safety Observation function)	(1)	A servo motor with functional safety is not connected.	Check if a servo motor with functional safety is connected.	It is not a servo motor with functional safety.	Connect a servo motor with functional safety.
				It is a servo motor with functional safety.	Check (2).	
		(2)	The functional safety unit is malfunctioning.	Replace the functional safety unit, and then check the repeatability.	It is not repeatable.	Replace the functional safety unit.
				It is repeatable.	Check (3).	
		(3)	The driver is malfunctioning.	Replace the driver, and then check the repeatability.	It is not repeatable.	Replace the driver.
It is repeatable.	Check (4).					
(4)	An encoder is malfunctioning.	Replace the servo motor, and then check the	It is not repeatable.	Replace the servo motor.		
			It is repeatable.	Check (5).		
(5)	Something near the device caused it.	Check the noise, ambient	There is a problem in the surrounding.	Take countermeasures against its cause.		

8. TROUBLESHOOTING

Alarm No.: 67		Name: Encoder normal communication error 1 (safety observation function)					
Alarm content		· An error has occurred in the communication between an encoder and driver.					
Detail No.	Detail name	Cause	Check method	Check result	Action		
67.1	Encoder normal communication - Receive data error 1 (safety observation function)	(1)	An encoder cable is malfunctioning.	Check if the encoder cable is disconnected or shorted.	It has a failure.	Repair or replace the cable.	
					It has no failure.	Check (2).	
		(2)	The driver is malfunctioning.	Replace the driver, and then check the repeatability.	It is not repeatable.	Replace the driver.	
					It is repeatable.	Check (3).	
		(3)	An encoder is malfunctioning.	Replace the servo motor, and then check the repeatability.	It is not repeatable.	Replace the servo motor.	
					It is repeatable.	Check (4).	
		(4)	Something near the device caused it.	Check the noise, ambient temperature, vibration, etc.	There is a problem in the surrounding.	Take countermeasures against its cause.	
		67.2	Encoder normal communication - Receive data error 2 (safety observation function)	Check it with the check method for [AL. 67.1].			
67.3	Encoder normal communication - Receive data error 3 (safety observation function)						
67.4	Encoder normal communication - Receive data error 4 (safety observation function)						
67.7	Encoder normal communication - Transmission data error 1 (safety observation function)						

Alarm No.: 68		Name: STO diagnosis error					
Alarm content		· An error of STO input signal was detected.					
Detail No.	Detail name	Cause	Check method	Check result	Action		
68.1	Mismatched STO signal error	(1)	STO1 and STO2 are not inputted correctly.	Check if the STO1 and STO2 of CN8 connector are wired correctly.	It is not wired correctly.	Wire it correctly.	
					It is wired correctly.	Check (2).	
		(2)	The input states of STO1 and STO2 are different.	Check the on/off states of STO1 and STO2.	The on/off states of STO1 and STO2 are different.	Set STO1 and STO2 to the same input states.	
					The on/off states of STO1 and STO2 are the same.	Check (3).	
		(3)	The setting of [Pr. PF18 STO diagnosis error detection time] ([Pr. PX43] for when the J3 extension function is used) is incorrect.	Set a longer time in the parameter, and then check the repeatability.	It is not repeatable.	Review the parameter setting.	
					It is repeatable.	Check (4).	
		(4)	The STO circuit is malfunctioning.	Replace the driver, and then check the repeatability.	It is not repeatable.	Replace the driver.	
					It is repeatable.	Check (5).	

8. TROUBLESHOOTING

		(5) Something near the device caused it.	Check the noise, ambient temperature, etc.	There is a problem in the surrounding.	Take countermeasures against its cause	
--	--	--	--	--	--	--

Alarm No.: 79		Name: Functional safety unit diagnosis error				
Alarm content		· A diagnosis of the functional safety unit failed.				
Detail No.	Detail name	Cause	Check method	Check result	Action	
79.1	Functional safety unit power voltage error	(1)	The power supply of the functional safety unit is failure.	Check the installation of the functional safety unit.	It has a failure.	Install it correctly.
					It has no failure.	Check (2).
		(2)	The functional safety unit is malfunctioning.	Replace the functional safety unit, and then check the repeatability.	It is not repeatable.	Replace the functional safety unit.
					It is repeatable.	Check (3).
		(3)	The driver is malfunctioning.	Replace the driver, and then check the repeatability.	It is not repeatable.	Replace the driver.
					It is repeatable.	Check (4).
		(4)	Something near the device caused it.	Check the power supply for noise.	There is a problem in the surrounding.	Take countermeasures against its cause.
		79.2	Functional safety unit internal error	(1)	The functional safety unit is malfunctioning.	Replace the functional safety unit, and then check the repeatability.
It is repeatable.	Check (2).					
(2)	Something near the device caused it.			Check the power supply for noise.	There is a problem in the surrounding.	Take countermeasures against its cause.
79.3	Abnormal temperature of functional safety unit	(1)	Ambient temperature has exceeded 55 °C.	Check the ambient temperature.	It is over 55 °C	Lower the ambient temperature.
					It is less than 55 °C	Check (2).
		(2)	Ambient temperature is less than 0 °C.	Check the ambient temperature.	It is less than 0 °C	Increase the ambient temperature.
					It is 0°C or more.	Check (3).
		(3)	The close mounting is out of specifications.	Check the specifications of close mounting.	It is out of specifications.	Mount it correctly
					It is within specifications.	Check (4).
		(4)	An opening is clogged up.	Clean the opening and check the repeatability.	It is not repeatable.	Clean it periodically.
					It is repeatable.	Check (5).
		(5)	The functional safety unit is malfunctioning.	Replace the functional safety unit, and then check the repeatability.	It is not repeatable.	Replace the functional safety unit.
					It is repeatable	Check (6).
		(6)	Something near the device caused it.	Check the power supply for noise.	There is a problem in the surrounding.	Take countermeasures against its cause.
		79.4	Driver error	(1)	The functional safety unit came off.	Check the installation of the functional safety unit.
It has no failure.	Check (2).					
(2)	The functional safety unit is malfunctioning.			Replace the functional safety unit, and then check the repeatability.	It is not repeatable.	Replace the functional safety unit.
					It is repeatable.	Check (3).
(3)	The driver is malfunctioning.			Replace the driver, and then check the repeatability.	It is not repeatable.	Replace the driver.
					It is repeatable.	Check (4).
(4)	Something near the device caused it.			Check the noise, ambient temperature, etc.	There is a problem in the surrounding.	Take countermeasures against its cause.

8. TROUBLESHOOTING

79.5	Input device error	(1)	A signal of input device is not inputted correctly.	Check if the input device cable is wired correctly.	It has a failure.	Review the wiring.
					It has no failure.	Check (2).
		(2)	The input device setting parameter is not set correctly.	Check if the parameter is set correctly.	It is not set correctly.	Review the parameter.
					It is set correctly.	Check (3).
		(3)	The test pulse time was not set correctly.	Check the setting of [Pr.PSD26 Input device -Test pulse off time].	The test pulse width is longer than the set value.	Set the value longer.
					The test pulse width is shorter than the set value.	Check (4).
		(4)	The functional safety unit is malfunctioning.	Replace the functional safety unit, and then check the repeatability.	It is not repeatable.	Replace the functional safety unit.
					It is repeatable.	Check (5).
		(5)	Something near the device caused it.	Check the noise, ambient temperature, etc.	There is a problem in the surrounding.	Take countermeasures against its cause.
		79.6	Output device error	(1)	A signal of an output device has not been outputted correctly.	Check if the output device cable is wired correctly. Or check if the load of the output device is within the specifications.
It has no failure.	Check (2).					
(2)	The test pulse time was not set correctly.			Check the setting of [Pr.PSD30 Output device -Test pulse off time].	The test pulse width is longer than the set value.	Set the value longer.
					The test pulse width is shorter than the set value.	Check (3).
(3)	Current of the output device is excessive.			Check if the current is used within prescribed	Not within prescribed.	Reduce the output current.
					Within prescribed.	Check (4).
(4)	The functional safety unit is malfunctioning.			Replace the functional safety unit, and then check the repeatability.	It is not repeatable.	Replace the functional safety unit.
					It is repeatable.	Check (5).
(5)	Something near the device caused it.			Check the noise, ambient temperature, etc.	There is a problem in the surrounding.	Take countermeasures against its cause.

8. TROUBLESHOOTING

79.7	Mismatched input signal error	(1)	A mismatch of input signal DI_A and DI_B continued for a fixed time ([Pr. PSD18] to [Pr. PSD23]).	Check if the input device cable is wired correctly.	It has a failure.	Review the wiring.
					It has no failure.	Check (2).
		(2)	An input mismatch time was not set correctly.	Check the settings of [Pr. PSD18 Mismatch permissible time DI1] to [Pr. PSD23 Mismatch permissible time DI6].	The mismatched time is longer than the set value.	Set the value longer.
					The mismatched time is shorter than the set value.	Check (3).
		(3)	The functional safety unit is malfunctioning.	Replace the functional safety unit, and then check the repeatability.	It is not repeatable.	Replace the functional safety unit.
			It is repeatable.	Check (4).		
(4)	Something near the device caused it.	Check the noise, ambient temperature, etc.	There is a problem in the surrounding.	Take countermeasures against its cause.		
79.8	Position feedback fixing error	(1)	The position feedback data do not change within the position feedback fixing error detection time [Pr. PSA22].	Check the [Pr. PSA22] setting.	It is not set correctly.	Review the parameter.
					It is set correctly.	Check (2).
		(2)	The position feedback data do not change.	Check the feedback data by rotating the servo motor.	The position feedback data changes.	Perform an operation which rotates the servo motor within the position feedback fixing error detection time [Pr. PSA22].
					The position feedback data do not change.	Check (3).
		(3)	The servo motor is malfunctioning.	Replace the servo motor, and then check the repeatability.	It is not repeatable.	Replace the servo motor.
			It is repeatable.	Check (4).		
(4)	The functional safety unit is malfunctioning.	Replace the functional safety unit, and then check the repeatability.	It is not repeatable.	Replace the functional safety unit.		

Alarm No.: 7A		Name: Parameter setting error (safety observation function)				
Alarm content		• A parameter of the functional safety unit failed.				
Detail No.	Detail name	Cause	Check method	Check result	Action	
7A.1	Parameter verification error (safety observation function)	(1)	A parameter of the functional safety unit is incorrect.	Review the parameter.	It is not repeatable.	Set the parameter correctly.
					It is repeatable.	Check (2).
		(2)	The functional safety unit is malfunctioning.	Replace the functional safety unit, and then check the repeatability.	It is not repeatable.	Replace the functional safety unit.
It is repeatable.	Check (3).					
(3)	Something near the device caused it.	Check the noise, ambient temperature, etc.	There is a problem in the surrounding.	Take countermeasures against its cause.		
7A.2	Parameter setting range error (safety observation function)	(1)	The initial settings for the functional safety unit have not been finished.	Check the [Pr. PSA01] setting.	It is not enabled.	Enable the setting with checking parameter contents.
					It is enabled.	Check (2).
		(2)	A parameter of the functional safety unit was set out of range.	Check the value of set parameters.	It is out of setting range.	Set it within the range.

8. TROUBLESHOOTING

7A.3	Parameter combination error (safety observation function)	(1)	A parameter of the functional safety unit or driver is incorrect.	Check the parameter settings of the functional safety unit and driver. Functional safety unit: [Pr. PSA02], [Pr. PSA18] to [Pr. PSA21], [Pr. PSC03], [Pr. PSD01] to [Pr. PSD17], [Pr. PSD26] driver:[Pr. PA14]	It is not set correctly.	Set the parameter correctly.
7A.4	Functional safety unit combination error (safety observation function)	(1)	A combination of functional safety unit and driver is incorrect.	Check if correct combination of driver is connected.	A different driver is connected	Return to the driver which was combined with the functional safety unit and was set the safety observation function, or initialize the setting.

Alarm No.: 7B		Name: Encoder diagnosis error (safety observation function)				
Alarm content		Error occurred in encoder.				
Detail No.	Detail name	Cause	Check method	Check result	Action	
7B.1	Encoder diagnosis error 1 (safety observation function)	(1)	An encoder cable is malfunctioning.	Check if the encoder cable is disconnected or shorted.	It has a failure.	Repair or replace the cable.
					It has no failure.	Check (2).
		(2)	An encoder is malfunctioning.	Replace the servo motor, and then check the repeatability.	It is not repeatable.	Replace the servo motor.
					It is repeatable.	Check (3).
		(3)	The functional safety unit is malfunctioning.	Replace the functional safety unit, and then check the repeatability	It is not repeatable.	Replace the functional safety unit.
					It is repeatable.	Check (4).
(4)	The driver is	Replace the driver, and then check the repeatability.	It is not repeatable.	Replace the driver.		
			It is repeatable.	Check (5).		
(5)	Something near the device caused it.	Check the noise, ambient temperature, vibration, etc.	There is a problem in the surrounding.	Take countermeasures against its cause.		
7B.2	Encoder diagnosis error 2 (safety observation function)	Check it with the check method for [AL. 7B.1].				
7B.3	Encoder diagnosis error 3 (safety observation function)					
7B.4	Encoder diagnosis error 4 (safety observation function)	(1)	Ambient temperature of the encoder has exceeded 40 °C.	Check the ambient temperature of the encoder.	It is over 40 °C.	Lower the ambient temperature.
					It is 40 °C or less.	Check (2).
		(2)	Ambient temperature of the encoder is less than 0 °C..	Check the ambient temperature of the encoder.	It is 0 °C or more.	Increase the ambient temperature.
					It is 0 °C or more.	Check (3).
		(3)	Servo motor is overloaded.	Check the effective load ratio.	The effective load ratio is high.	Reduce the load or review the operation pattern.
					The effective load ratio is small.	Check (4).
		(4)	The thermal sensor in the encoder is malfunctioning.	Replace the servo motor, and then check the repeatability.	It is not repeatable.	Replace the servo motor.
					It is repeatable.	Check (5).
		(5)	The functional safety unit is malfunctioning.	Replace the functional safety unit, and then check the repeatability.	It is not repeatable.	Replace the functional safety unit.

8. TROUBLESHOOTING

Alarm No.: 7D		Name: Safety observation error				
Alarm content		• The safety observation function detected an error.				
Detail No.	Detail name	Cause	Check method	Check result	Action	
7D.1	Stop observation error	(1)	During activation of SOS function, the position of the servo motor has changed by more than the SOS allowance value set by parameter	Check that the actual servo motor position is higher than the setting value of [Pr. PSA05].	The travel distance of the servo motor is larger than the setting value in [Pr.PSA05].	Review the alarm level.
					The travel distance of the servo motor is smaller than the alarm detection level.	Check (2).
		(2)	During activation of SOS function, the servo motor speed has changed by larger than the SOS allowance value set by parameter, and that state has continued for longer than the set time (specified by [Pr.PSA15]).	The actual servo motor speed is higher than the setting value of [Pr.PSA04].	The servo motor speed is higher than the setting value in [Pr. PSA04].	Review the parameter setting.
					The servo motor speed is higher than the setting value in [Pr. PSA15] and equal to or lower than that in [Pr.PSA04].	Check (3).
		(3)	During activation of SOS function, the speed command has changed by larger than the SOS allowance value set by parameter, and that state has continued for longer than the set time (specified by [Pr. PSA15]).	Check if the command from the controller is over the standstill speed set in [Pr. PSA04].	The command from the controller is over the setting valued in [Pr.PSA04].	Check the operation pattern.
					The command from controller is higher than the setting value in [Pr.PSA15] and equal to or lower than that in [Pr.PSA04].	Check (4).
		(4)	An encoder is malfunctioning.	Replace the servo motor, and then check the repeatability.	It is not repeatable.	Replace the servo motor.
					It is repeatable.	Check (5).
		(5)	The functional safety unit is malfunctioning.	Replace the functional safety unit, and then check the repeatability.	It is not repeatable.	Replace the functional safety unit.
					It is repeatable.	Check (6).
		(6)	The driver is malfunctioning.	Replace the driver, and then check the repeatability.	It is not repeatable.	Replace the servo motor.
					It is repeatable.	Check (7).
		(7)	Something near the device caused it.	Check the noise, ambient temperature, vibration, etc.	There is a problem in the surrounding.	Take countermeasures against its cause.
		7D.2	Speed observation error	(1)	The command pulse frequency is high.	Check the command pulse frequency.
The command pulse [GF] frequency is low.	Check (2).					
(2)	The settings of the electronic gear are incorrect.			Check the setting value of the electronic gear.	The setting value is incorrect.	Review the settings.
					The setting value is correct.	Check (3).
(3)	The command from the controller is excessive.			Check if the command from the controller is the SLS speed ([Pr. PSA11] to [Pr. PSA14]) or more.	It is over the permissible speed.	Check operation pattern.
					It is less than the permissible speed.	Check (4).
(4)	A larger speed command than the SLS speed ([Pr. PSA11] to [Pr. PSA14]) was inputted.			Check that the actual servo motor speed is higher than the setting value of the SLS speed.	The servo motor speed is higher than the SLS speed.	Review the setting value of the SLS speed.
					The servo motor speed is lower than the SLS speed.	Check (5).
(5)	The servo system is			Check if the servo	It is oscillating.	Adjust the servo gain. Or reduce the load.

8. TROUBLESHOOTING

			unstable and oscillating.	motor is oscillating.	It is not oscillating.	Check (6).
		(6)	The velocity waveform has overshoot.	Check if it is overshooting because the acceleration time constant is too short.	It is overshooting.	Increase the acceleration/deceleration time constant.
					It is not overshooting.	Check (7).
		(7)	The connection destination of the encoder cable is incorrect.	Check the connection destination of the encoder.	It is not correct.	Wire it correctly.
					It is correct.	Check (8).
		(8)	The encoder or linear encoder is malfunctioning.	Replace the servo motor, and then check the repeatability.	It is not repeatable.	Replace the servo motor.
					It is repeatable.	Check (9).
		(9)	The functional safety unit is malfunctioning.	Replace the functional safety unit, and then check the repeatability.	It is not repeatable.	Replace the functional safety unit.
					It is repeatable.	Check (10).
		(10)	The driver is malfunctioning.	Replace the driver, and then check the repeatability.	It is not repeatable.	Replace the driver.
					It is repeatable.	Check (11).
		(11)	Something near the device caused it.	Check the noise, ambient temperature, etc.	There is a problem in the surrounding.	Take countermeasures against its cause.

Alarm No.: 8A		Name: USB communication time-out error/serial communication time-out error/Modbus RTU communication time-out error				
Alarm content		<ul style="list-style-type: none"> • Communication between the driver and a personal computer/controller stopped for the specified time or longer. • An error occurred in USB communication, serial communication (Mitsubishi Electric general-purpose) 				
Detail No.	Detail name	Cause	Check method	Check result	Action	
8A.1	USB communication time-out error/serial communication time-out error	(1)	Communication commands have not been transmitted.	Check if a command was transmitted from the personal computer, etc.	It was not transmitted.	Transmit a command.
					It was transmitted.	Check (2).
		(2)	A communication cable was disconnected.	Replace the communication cable, and then check the repeatability.	It is not repeatable.	Replace the communication cable.
					It is repeatable.	Check (3).
		(3)	The driver is malfunctioning.	Replace the driver, and then check the repeatability.	It is not repeatable.	Replace the driver.

8. TROUBLESHOOTING

Alarm No.: 8E		Name: USB communication error/serial communication error/Modbus RTU communication error				
Alarm content		<ul style="list-style-type: none"> • A communication error occurred between the driver and a personal computer/controller. • An error occurred in USB communication, serial communication (Mitsubishi Electric general-purpose AC servo protocol), or Modbus RTU communication. 				
Detail No.	Detail name	Cause	Check method	Check result	Action	
8E.1	USB communication receive error/serial communication receive error	(1) The setting of the personal computer, etc. is incorrect.	Check the setting of the personal computer, etc.	It is incorrect.	Review the settings.	
				It is correct.	Check (2).	
		(2) A communication cable is malfunctioning.	Check the communication cable, and then check the repeatability.	It is not repeatable.	Replace the communication cable.	
	It is repeatable.	Check (3).				
		(3) The driver is malfunctioning.	Replace the driver, and then check the repeatability.	It is not repeatable.	Replace the driver.	
8E.2	USB communication checksum error/serial communication checksum error	(1) The setting of the personal computer, etc. is incorrect.	Check the setting of the personal computer, etc.	It is incorrect.	Review the settings.	
8E.3	USB communication character error/serial communication character error	(1) The transmitted character is out of specifications.	Check the character code at the time of transmission.	The transmitted character is out of specifications.	Correct the transmission data.	
				The transmitted [RJ010] character is within specifications.	Check (2).	
		(2) The communication protocol is failure.	Check if transmission data supports the communication protocol.	It is not conforming.	Replace the communication cable.	
	It is conforming.	Check (3).				
		(3) The setting of the personal computer, etc. is incorrect.	Check the setting of the personal computer, etc.	It is not repeatable.	Replace the driver.	
8E.4	USB communication command error/serial communication command error	(1) The transmitted command is out of specifications.	Check the command at the time of transmission.	The transmitted command is out of specifications.	Correct the transmission data.	
				The transmitted command is within specifications.	Check (2).	
		(2) The communication protocol is failure.	Check if transmission data supports the communication protocol.	It is not conforming.	Modify the transmission data according to the communication protocol.	
	It is conforming.	Check (3).				
		(3) The setting of the personal computer, etc. is incorrect.	Check the setting of the personal computer, etc.	It is incorrect.	Review the settings.	
8E.5	USB communication data number error/serial communication data number error	(1) The transmitted data number is out of specifications.	Check the data number at the time of transmission.	The transmitted data number is out of specifications.	Correct the transmission data.	
				The transmitted data number is within specifications.	Check (2).	
		(2) The communication protocol is failure.	Check if transmission data supports the communication protocol.	It is not conforming.	Modify the transmission data according to the communication protocol.	
	It is conforming.	Check (3).				
		(3) The setting of the personal computer, etc. is incorrect.	Check the setting of the personal computer, etc.	It is incorrect.	Review the settings.	

8. TROUBLESHOOTING

Alarm No.: 88888		Name: Watchdog				
Alarm content		• A part such as CPU is malfunctioning.				
Detail No.	Detail name	Cause		Check method	Check result	Action
88._	Watchdog	(1)	A part in the driver is failure.	Replace the driver, and then check the repeatability.	It is not repeatable.	Replace the driver.

8. TROUBLESHOOTING

8.5 Remedies for warnings



CAUTION

● If [AL. E3 Absolute position counter warning] occurs, always make the home position setting again. Otherwise, it may cause an unexpected operation.

POINT
<ul style="list-style-type: none"> ● When any of the following warnings occurs, do not cycle the power of the driver repeatedly to restart. Doing so will cause a malfunction of the driver and servo motor. If the power of the driver is switched off/on during the warnings, allow more than 30 minutes for cooling before resuming operation. <ul style="list-style-type: none"> ▪ [AL. 91 Driver overheat warning] ▪ [AL. E0 Excessive regeneration warning] ▪ [AL. E1 Overload warning 1] ▪ [AL. E2 Servo motor overheat warning] ▪ [AL. EC Overload warning 2] ● Warnings (except [AL. F0 Tough drive warning]) are not recorded in the alarm history.

If [AL. E6] or [AL. E9] occurs, the amplifier will be the servo-off status. If any other warning occurs, operation can be continued but an alarm may occur and proper operation may not be performed.

Refer to this section and remedies for warnings, remove the cause of a warning. Use Setup software (MR Configurator2™) to refer to the cause of warning occurrence.

Alarm No.: 90		Name: Home position return incomplete warning				
Alarm content		A home position return did not complete normally with the positioning function.				
Detail No.	Detail name	Cause	Check method	Check result	Action	
90.1	Home position return incomplete	(1) An automatic operation was executed at home position return incompleteness.	Check if the home position return was not executed (the following devices are not off.). ZP (Home position return completion)	A home position return was not executed. A home position return was executed.	Execute a home position return. Check (2).	
		(2) A positioning operation was executed without home position setting with absolute position after [AL. 25 Absolute position erased] occurred.	Check if [AL. 25 Absolute position erased] occurred using alarm history.	[AL. 25 Absolute position erased] occurred. [AL. 25 Absolute position erased] did not occur.	Check the battery voltage and battery cable if they have a failure and execute a home position return after remove the failure. Check (3).	
		(3) With the indexer method, [AL. E3 Absolute position counter warning] Occurred simultaneously with the alarm.	Check if [AL. 90.1] occurred simultaneously with start of the positioning operation.	[AL. 90.1] did not occur simultaneously with start of the positioning operation but occurred during positioning operation. [AL. 90.1] occurred simultaneously with start of the positioning operation.	Remove the cause of [AL. E3], and perform home position return. (Check it with the check method for [AL. E3].) Check (4).	
		(4) ZP (Home position return completion) turned off after the home position return was executed.	Check if ZP (Home position return completion) is off.	ZP (Home position return completion) is off.	Check the conditions if ZP (Home position return completion) can be off. (Positioning Mode)"	

8. TROUBLESHOOTING

Alarm No.: 90		Name: Home position return incomplete warning			
Alarm content		□□A home position return did not complete normally with the positioning function.			
Detail No.	Detail name	Cause	Check method	Check result	Action
90.2	Home position return abnormal termination	(1)	The proximity dog is not connected to DOG.	Check if the proximity dog is connected correctly.	It is not connected. Connect it correctly.
				It is connected. Check (2).	
		(2)	The stroke limit was detected after the home position return start.	Check if the stroke limit is connected correctly. Or check if the stroke limit is not reached.	The stroke limit is not connected. Or the stroke limit is reached. Connect the stroke limit correctly. Review the stroke limit position.
				The stroke limit is connected. Or the stroke limit is not reached.	Check (3).
(3)	A home position return speed did not decelerate to a creep speed.	Check if the proximity dog turned off before a home position return completed deceleration to a creep speed.	The proximity dog turned off before the deceleration to a creep speed.	Review the dog position. Or review the parameter values of the home position return speed, creep speed, and travel distance after proximity dog.	
(4)	Deceleration from the home position return speed/creep speed to the home position failed at the indexer method.	Check if the home position was turned on before the deceleration from the home position return speed/creep speed to the home position was complete.	It was not turned on before the deceleration was complete.	Review the positional relationship of the stroke limit and home position. Or review the parameter values of the home position return speed, creep speed, deceleration time constant, and home position shift distance.	
90.5	Z-phase unpassed	(1)	The Z-phase signal was not detected normally.	Check if the Z-phase signal of the servo motor was detected normally.	The Z-phase signal was not detected. Review the Z-phase signal and wirings.
				The Z-phase signal was detected. Check (2).	
(2)	A home position return was executed while the servo motor did not pass the Z-phase.	Check if the motor passed the Z-phase signal until the proximity dog turned off after the home position return started.	The Z-phase was not turned on.	Review the setting position of the home position return start and proximity dog.	

Alarm No.: 91		Name: driver overheat warning			
Alarm content		• The temperature inside of the driver reached a warning level.			
Detail No.	Detail name	Cause	Check method	Check result	Action
91.1	Main circuit device overheat warning	(1)	Ambient temperature of the driver has exceeded 55 °C	Check the ambient temperature.	It is over 55 °C. Lower the ambient temperature.
				It is less than 55 °C. Check (2).	
(2)	The close mounting is out of specifications.	Check the specifications of close mounting.	It is out of specifications.	Use within the range of specifications.	

8. TROUBLESHOOTING

Alarm No.: 92		Name: Battery cable disconnection warning			
Alarm content		<ul style="list-style-type: none"> □ Battery voltage for absolute position detection system decreased. 			
Detail No.	Detail name	Cause	Check method	Check result	Action
92.1	Encoder battery cable disconnection warning	(1)	1) When a battery was used, the battery was not connected to CN4.	Check if the battery is connected correctly.	It is not connected. Connect it correctly.
				It is connected. Check (2).	
		(2)	A battery cable was disconnected.	Check if the battery cable is malfunctioning.	It has a failure. Replace or repair the cable.
				It has no failure. Check (3).	
(3)	The battery voltage is low. The battery is consumed.	Check the battery voltage with a tester.	It is less than 3.1 V DC. Replace or repair the cable.		
			It is 3.1 V DC or more. Replace the battery.		
(4)	An encoder cable was disconnected.	Check if the encoder cable is disconnected.	It is disconnected. Replace or repair the cable.		
92.3	Battery degradation	(1)	The battery voltage is low. The battery is consumed	Check the battery voltage with a tester.	It is less than 3.0 V DC. Replace the battery.
				It is 3.0 V DC or more. Check (2).	
(2)	The battery has deteriorated.	Replace the battery, and then check the	It is not repeatable. Replace the battery.		

Alarm No.: 95		Name: STO warning			
Alarm content		<ul style="list-style-type: none"> • STO input signal turns off while the servo motor stops. • A diagnosis of input devices was not executed. • The safety observation function was enabled in the test mode. 			
Detail No.	Detail name	Cause	Check method	Check result	Action
95.1	STO1 off detection	(1)	STO1 is not inputted correctly.	Check if the STO1 of CN8 connector is wired correctly.	It is not wired correctly. Wire it correctly. (When not using the STO function, attach the shortcircuit connector came with the driver to CN8.)
				It is wired correctly. Check (2).	
95.2	STO2 off detection	(2)	STO1 was turned off (enabled) under the following speed conditions. 1) Servo motor speed: 50 r/min or less	Check if STO1 is off (enabled).	It is off (enabled). Turn on STO1 (disabled).
				STO2 is not inputted correctly.	Check if the STO2 of CN8 connector is wired correctly.
95.3	STO warning 1	(1)	"Input device -	Check if "Input device -	It is off (enabled). Turn on STO2(disabled).
				It was not executed. Execute it.	

8. TROUBLESHOOTING

	(safety observation function)		Fixing diagnosis Execution selection at start-up" was not executed.	Fixing-diagnosis execution selection at start-up" was executed	It was executed.	Check (2).
		(2)	Set "Input device - Fixing-diagnosis execution selection at start-up" correctly using parameters.	Check if [Pr. PSD27] and [Pr. PSD28] are set correctly.	It is not set correctly. It is set correctly.	Review the parameter Check (3).
		(3)	The wiring is incorrect.	Check if the wiring has a failure.	It has a failure. It has no failure.	Review the wiring. Check (4).
		(4)	The functional safety unit is malfunctioning.	Replace the functional safety unit, and then check the repeatability.	It is not repeatable. It is repeatable.	Replace the functional safety unit. Check (5).
		(5)	Something near the device caused it.	Check the noise, ambient temperature, etc.	There is a problem in the surrounding.	Take countermeasures against its cause.
95.4	STO warning 2 (safety observation function)	(1)	The test operation mode was not set correctly.	Check if the driver and functional safety unit are set to the test operation mode.	It is not set. It is set.	Set it correctly. Check (2).
		(2)	An error occurred in the safety communication. Or the network is disconnected.	Check the description "The display shows "Ab"." . ⇒Page 124 Trouble which does not trigger alarm/warning	It is not repeatable. It is repeatable.	Take countermeasures against its cause. Check (3).
		(3)	"Input mode selection" in [Pr. PSA02 Functional safety unit setting] is not set correctly.	Set [Pr. PSA02] correctly and check the repeatability.	It is not repeatable. It is repeatable.	Review the parameter. Check (4).
		(4)	The driver is malfunctioning.	Replace the driver, and then check the repeatability.	It is not repeatable. It is repeatable.	Replace the driver. Check (7).
		(5)	The functional safety unit is malfunctioning.	Replace the functional safety unit, and then check the repeatability.	It is not repeatable. It is repeatable.	Replace the functional safety unit. Check (8).
		(6)	Something near the device caused it.	Check the noise, ambient temperature, etc.	There is a problem in the surrounding.	Take countermeasures against its cause.
95.5	STO warning 3 (safety observation function)	(1)	STO command/SS1 command of the functional safety unit was turned off (enabled) under the following speed conditions. 1) Servo motor speed: 50 r/min or less	Check if STO command/ SS1 command of the functional safety unit is off (enabled).	It is off (enabled).	Turn on (disabled) STO command/SS1 command of the functional safety unit.

Alarm No.: 96		Name: Home position setting warning			
Alarm content		• <input type="checkbox"/> Home position setting could not be made.			
Detail No.	Detail name	Cause	Check method	Check result	Action
96.1	In-position warning at home positioning	(1) INP (In-position) did not turn on within the specified time during home positioning.	Check the droop pulses during home positioning.	It is In-position range or more.	Adjust gains to set droop pulses within the Inposition range. Remove the cause of droop pulse occurrence, and make home position setting.
96.2	Command input warning at home positioning	(1)	A command has already inputted at the time of home positioning.	Check if a command is inputted at home positioning. A command is inputted. A command is not inputted.	Set it after home positioning. Check (2).
		(2)	Creep speed is high.	Decrease the creep speed, and then check	It is not repeatable. Decelerate the creep speed, and make home

8. TROUBLESHOOTING

				the repeatability.		position setting.
96.3	Servo off warning at home positioning	(1)	A home positioning was executed during servo-off.	Check if the status is servo-off at home positioning.	It is servo-off.	Turn to servo-on, and then execute the home positioning.
96.4	Home positioning warning during magnetic pole detection	(1)	Z-phase was not turned on after servo-on.	Check if the Z-phase was turned on.	The Z-phase was not turned on.	Rotate the direct drive motor to turn on the Zphase, and make home position setting.

Alarm No.: 98		Name: Software limit warning				
Alarm content		• A software limit set with the parameter was reached for the positioning function.				
Detail No.	Detail name	Cause	Check method	Check result	Action	
98.1	Forward rotation-side software stroke limit reached	(1)	A software limit was set within the actual operation range.	Check if the parameter settings ([Pr. PT15] to [Pr. PT18]) to the operation range are correct.	The setting was out of operation range.	Set [Pr. PT15] to [Pr. PT18] correctly.
					The setting was within operation range.	Check (2).
		(2)	A point table of the position data which exceeds the software limit was executed.	Check if the target position of the point data to the operation range was correct.	The setting was out of operation range.	Set the point table correctly.
				The setting was within operation range.	Check (3).	
(3)	A software limit was reached by using the JOG operation or manual pulse generator operation.	Check if the JOG operation or manual pulse generator operation was executed properly to the operation range.	It reached to the out of operation range.	Operate within the software limit. Adjust properly the parameters such as JOG speed and multiplication of the manual pulse as necessary.		
98.2	Reverse rotation-side software stroke limit reached	Check it with the check method for [AL. 98.1].				

Alarm No.: 99		Name: Stroke limit warning				
Alarm content		□□The stroke limit signal is off.				
Detail No.	Detail name	Cause	Check method	Check result	Action	
99.1	Forward rotation stroke end off	(1)	The forward rotation stroke limit switch is connected to LSP.	Check if the limit switch is connected correctly.	It is not connected.	Connect it correctly.
					It is connected.	Check (2).
					It turned off.	Check operation attern.
(2)	The forward rotation stroke end was exceeded during driving.	Check if the forward rotation stroke limit switch turned off.	It is not connected.	Set the point table correctly.		
			It is connected.	Check (3).		
99.2	Reverse rotation stroke end off	(1)	The reverse rotation stroke limit switch is connected to LSN.	Check if the limit switch is connected correctly.	It is not connected.	Connect it correctly.
					It is connected.	Check (2).
(2)	The reverse rotation stroke end was exceeded during driving.	Check if the reverse rotation stroke limit switch turned off.	It turned off.	Check operation pattern.		

Alarm No.: 9B		Name: Error excessive warning				
Alarm content		•Droop pulses have exceeded the warning occurrence level.				
Detail No.	Detail name	Cause	Check method	Check result	Action	
9B.1	Excess droop pulse 1 warning	(1)	The servo motor power cable was disconnected.	Check the servo motor power cable.	It is disconnected.	Repair or replace the servo motor power cable.
					It is not disconnected.	Check (2).

8. TROUBLESHOOTING

		(2)	The connection of the servo motor is incorrect	Check the wiring of U/V/W.	It is incorrect. It is correct.	Connect it correctly. Check (3).
		(3)	The connection of the encoder cable is incorrect.	Check if the encoder cable is connected correctly.	It is incorrect. It is correct.	Connect it correctly. Check (4).
		(4)	The torque limit has been enabled.	Check if the limiting torque is in progress.	The limiting torque is in progress. The limiting torque is not in progress.	Increase the torque limit value. Check (5).
		(5)	A moving part collided against the machine.	Check if it collided.	It collided. It did not collide.	Check operation pattern. Check (6).
		(6)	The torque is insufficient.	Check the peak load Ratio	The torque is saturated. The torque is not saturated.	Reduce the load or review the operation pattern. Or use a larger capacity motor. Check (7).
		(7)	Power supply voltage dropped.	Check the bus voltage value.	The bus voltage is low The bus voltage is high.	Check the power supply voltage and power supply capacity. Check (8).
		(8)	Acceleration/ deceleration time constant is too short.	Set a longer deceleration time constant, and then check the repeatability.	It is not repeatable. It is repeatable.	Increase the acceleration/deceleration time constant. Check (9).
		(9)	The position loop gain is small.	Increase the position loop gain, and then check the repeatability.	It is not repeatable. It is repeatable.	Increase the position loop gain (Pr. PB08). Check (10).
		(10)	Servo motor shaft was rotated by external force.	Measure the actual position under the servolock status.	It is rotated by external force. It is not rotated by external force.	Review the machine. Check (11).
		(11)	An encoder is malfunctioning.	Replace the servo motor, and then check the repeatability.	It is not repeatable.	Replace the servo motor.
		9B.3	Excess droop pulse 2 warning	Check it with the check method for [AL. 9B.1].		
9B.4	Error excessive warning during 0 torque limit	(1)	The torque limit has been 0.	Check the torque limit value.	The torque limit has been 0.	Do not input a command while the torque limit value is 0.

Alarm No.: 9F		Name: Battery warning				
Alarm content		• Battery voltage for absolute position detection system decreased.				
Detail No.	Detail name	Cause	Check method	Check result	Action	
9F.1	Low battery	(1)	The battery is not connected to CN4.	Check if the battery is connected correctly.	It is not connected. It is connected.	Connect it correctly. Check (2).
		(2)	The battery voltage is low. The battery is consumed.	Check the battery voltage with a tester.	It is less than 4.9 V DC.	Replace the battery.
9F.2	Battery degradation warning	(1)	The absolute position storage unit has not connected.	Check if the absolute position storage unit is connected correctly.	It is not connected.	Connect it correctly.

Alarm No.: E0		Name: Excessive regeneration warning				
Alarm content		• There is a possibility that regenerative power may exceed permissible regenerative power of built-in regenerative resistor or regenerative option.				
Detail No.	Detail name	Cause	Check method	Check result	Action	
E0.1	Excessive Regeneration warning	(1)	The regenerative power exceeded 85% of the permissible regenerative	Check the effective load ratio.	It is 85% or more.	Reduce the frequency of positioning. Increase the deceleration

8. TROUBLESHOOTING

		power of the built-in regenerative resistor or regenerative option.			time constant. Reduce the load. Use a regenerative option if it is not being used.
--	--	---	--	--	--

Alarm No.: E1		Name: Overload warning 1				
Alarm content		<input type="checkbox"/> [AL. 50 Overload 1] or [AL. 51 Overload 2] can occur.				
Detail No.	Detail name	Cause	Check method	Check result	Action	
E1.1	Thermal overload warning 1 during operation	(1) The load was over 85% to the alarm level of [AL. 50.1 Thermal overload error 1 during operation].	Check it with the check method for [AL. 50.1].			
E1.2	Thermal overload warning 2 during operation	(1) The load was over 85% to the alarm level of [AL. 50.2 Thermal overload error 2 during operation].	Check it with the check method for [AL. 50.2].			
E1.3	Thermal overload warning 3 during operation	(1) The load was over 85% to the alarm level of [AL. 51.1 Thermal overload error 3 during operation].	Check it with the check method for [AL. 51.1].			
E1.4	Thermal overload warning 4 during operation	(1) The load was over 85% to the alarm level of [AL. 50.3 Thermal overload error 4 during operation].	Check it with the check method for [AL. 50.3].			
E1.5	Thermal overload error 1 during a stop	(1) The load was over 85% to the alarm level of [AL. 50.4 Thermal overload error 1 during a stop].	Check it with the check method for [AL. 50.4].			
E1.6	Thermal overload error 2 during a stop	(1) The load was over 85% to the alarm level of [AL. 50.5 Thermal overload error 2 during a stop].	Check it with the check method for [AL. 50.5].			
E1.7	Thermal overload error 3 during a stop	(1) The load was over 85% to the alarm level of [AL. 51.2 Thermal overload error 3 during operation].	Check it with the check method for [AL. 51.2].			
E1.8	Thermal overload error 4 during a stop	(1) The load was over 85% to the alarm level of [AL. 50.6 Thermal overload error 4 during a stop].	Check it with the check method for [AL. 50.6].			

Alarm No.: E2		Name: Servo motor overheating warning				
Alarm content		[AL. 46.2 Abnormal temperature of servo motor 2] can occur.				
Detail No.	Detail name	Cause	Check method	Check result	Action	
E2.1	Servo motor temperature warning	(1) The temperature of the linear servo motor or direct drive motor reached 85% of the occurrence level of [AL. 46.2 Abnormal temperature of servo motor 2].	Check it with the check method for [AL. 46.2].			

8. TROUBLESHOOTING

Alarm No.: E3		Name: Absolute position counter warning				
Alarm content		<ul style="list-style-type: none"> • The multi-revolution counter value of the absolute position encoder exceeded the maximum range. • Absolute position encoder pulses are faulty. • An update cycle is short for writing multi-revolution counter value of the absolute position encoder to EEPROM. 				
Detail No.	Detail name	Cause	Check result	Action	Target	
E3.1	Multi-revolution counter travel distance excess warning	(1) The travel distance from the home position is 32768 rev or more in the absolute position system.	Check the value of the multi-revolution counter.	It is 32768 rev or more.	Review operation range. Execute the home position return again. After the power is surely cycled, perform home position return again.	
E3.2	Absolute position counter warning	(1) Something near the device caused it.	Check the noise, ambient temperature, etc.	There is a problem in the surrounding.	Take countermeasures against its cause. After the power is surely cycled, perform home position return again.	
		(2) An encoder is malfunctioning.	Replace the servo motor, and then check the repeatability.	It is not repeatable.	Check (2). Replace the servo motor.	
E3.4	Absolute positioning counter EEPROM writing frequency warning	(1) A home position was renewed (EEP-ROM write) twice or more in 10 minutes in the driver due to rotation to the same direction in short time in the point table method of the positioning mode, degree setting with the program method, or the indexer method.	Check if the operation was within the following conditions between the number of gear teeth on machine side ([Pr. PA06] CMX) and servo motor speed (N). • When CMX $\square\square 2000$, N < 3076.7 r/min • When CMX > 2000, N < 3276.7 - (CMX \times 0.1) r/min • When (CMX/CDV) is reduced to its lowest terms, CMX 15900	The operation was out of conditions.	Set the command speed within the conditions. Set the number of gear teeth on machine side within the conditions. After the power is surely cycled, perform home position return again.	
E3.5	Encoder absolute positioning counter warning	Check it with the check method for [AL. E3.2].				

8. TROUBLESHOOTING

Alarm No.: E6		Name: Servo forced stop warning				
Alarm content		<ul style="list-style-type: none"> • EM2/EM1 (Forced stop) turned off. • SS1 command was inputted. 				
Detail No.	Detail name	Cause	Check method	Check result	Action	
E6.1	Forced stop warning	(1) EM2/EM1 (Forced stop) turned off.	Check the status of EM2/EM1.	It is off.	Ensure safety and turn on EM2/EM1 (Forced stop).	
				It is on.	Check (2).	
		(2) The external 24 V DC power supply is off.	Check if the external 24 V DC power supply is inputted.	It is not inputted.	Input the 24 V DC power supply.	
		It is inputted.	Check (3).			
E6.2	SS1 forced stop warning 1 (safety observation function)	(3) The driver is malfunctioning.	Replace the driver, and then check the repeatability.	It is not repeatable.	Replace the driver.	
		(1) The SS1 command is off (enabled).	Check if the SS1 command is off (enabled).	The SS1 command is off (enabled).	Turn on the SS1 input (disabled).	
		(2) An external 24 V DC is not inputted to the functional safety unit.	Check if an external 24 VDC is inputted to the functional safety unit.	It is not inputted.	Input the 24 V DC power supply.	
		It is inputted.	Check (3).			
E6.3	SS1 forced stop warning 2 (safety observation function)	(3) The functional safety unit is malfunctioning.	Replace the functional safety unit, and then check the repeatability.	It is not repeatable.	Replace the functional safety unit.	
		(1) An error occurred in the safety communication.	Check the description "The display shows "Ab"." ⇒ Page 124 Trouble which does not trigger alarm/warning	It is not repeatable.	Take countermeasures against its cause.	

Alarm No.: E7		Name: Controller forced stop warning				
Alarm content		The forced stop signal of the servo system controller was enabled.				
Detail No.	Detail name	Cause	Check method	Check result	Action	
E7.1	Controller forced stop input warning	(1) The forced stop signal of the controller was inputted with Modbus RTU communication.	Check if the controller is in a forced stop status.	It is the forced stop status.	Ensure safety and cancel the forced stop signal of the controller.	

Alarm No.: E8		Name: Cooling fan speed reduction warning				
Alarm content		• The cooling fan speed decreased to the warning occurrence level or less.				
Detail No.	Detail name	Cause	Check method	Check result	Action	
E8.1	Decreased cooling fan speed warning	(1) Foreign matter was caught in the cooling fan.	Check if a foreign matter is caught in the cooling fan.	Something has been caught.	Remove the foreign matter.	
				Nothing has been caught.	Check (2).	
		(2) Cooling fan life expired.	Check the total of power on time of the driver.	It exceed the cooling fan life.	Replace the driver.	
E8.2	Cooling fan stop	Check it with the check method for [AL. E8.1].				

8. TROUBLESHOOTING

Alarm No.: E9		Name: Main circuit off warning			
Alarm content		<ul style="list-style-type: none"> • The servo-on command was inputted with main circuit power supply off • The bus voltage dropped during the servo motor driving under 50 r/min. 			
Detail No.	Detail name	Cause	Check method	Check result	Action
E9.1	Servo-on signal on during main circuit off	(1) The main circuit power supply is off. For the drive unit, the power supply of the converter unit is off.	Check if the main circuit power supply is inputted. Check if the power supply of the converter unit is inputted.	It is not inputted.	Turn on the main circuit power.
				It is inputted.	Check (2).
		(2) The wiring between P3 and P4 was disconnected. For the drive unit, the wiring between P1 and P2 of the converter unit was disconnected.	Check the wiring between P3 and P4. Check the wiring between P1 and P2 of the converter unit.	It is disconnected.	Connect it correctly.
				It is connected.	Check (3).
		(3) The main circuit power supply wiring was disconnected. For the drive unit, the main circuit power supply wiring of the converter unit was disconnected.	Check the main circuit power supply wiring. Check the main circuit power supply wiring of the converter unit.	It is disconnected.	Connect it correctly.
				It has no failure.	Check (4).
		(4) For the drive unit, the magnetic contactor control connector of the converter unit was disconnected.	Check the magnetic contactor control connector of the converter unit.	It is disconnected.	Connect it correctly.
				It has no failure.	Check (5).
		(5) For the drive unit, the bus bar between the converter unit and drive unit was disconnected.	Check the bus bar between the converter unit and drive unit.	It is disconnected.	Connect it correctly.
				It has no failure.	Check (6).
		(6) The setting value of [Pr. PA02 Magnetic contactor drive output selection] contradicts the wiring constitution.	Check the [Pr. PA02] setting and the wiring constitution.	The setting or wiring is incorrect.	Review the setting of [Pr. PA02].
				The setting and wiring are correct.	Check (7).
				The setting is correct.	Check (8).
(8) The bus voltage is low.	Check if the bus voltage is lower than the prescribed value. 215 V DC	The voltage is lower than the prescribed value.	Review the wiring. Check the power supply capacity.		
		The voltage is equal to or higher than the prescribed value.	Check (9).		
(9) The driver is malfunctioning.	Replace the driver, and then check the repeatability.	It is not repeatable.	(10) Replace the driver.		
(10) For the drive unit, the converter unit is malfunctioning.	Replace the converter unit, and then check the repeatability.	It is not repeatable.	Replace the converter unit.		
E9.2	Bus voltage drop during low speed operation	(1) The bus voltage dropped during the servo motor driving under 50 r/min.	Check the bus voltage.	It is lower than the prescribed value. 200 V	Review the power supply capacity. Increase the acceleration time constant.
E9.3	Ready-on signal on during main circuit off	Check it with the check method for [AL. E9.1].			

8. TROUBLESHOOTING

Alarm No.: EC		Name: Overload warning 2			
Alarm content		Operations over rated output were repeated while the servo motor shaft was not rotated.			
Detail No.	Detail name	Cause	Check method	Check result	Action
EC.1	Overload warning 22	(1) The load is too large or the capacity is not enough.	Check the effective load ratio.	The effective load ratio is high.	Reduce the load. Replace the servo motor with the one of larger capacity.

Alarm No.: ED		Name: Output watt excess warning			
Alarm content		· The status, in which the output wattage (speed × torque) of the servo motor exceeded the rated output, continued steadily.			
Detail No.	Detail name	Cause	Check method	Check result	Action
ED.1	Output watt excess warning	(1) The status, in which the output wattage (speed × torque or thrust) of the servo motor exceeded 120% of the rated output (continuous thrust), continued steadily.	Check the servo motor speed and torque, or check the motor speed and thrust.	The output wattage is 120% of rating.	Reduce the servo motor speed. Reduce the load.

Alarm No.: F0		Name: Tough drive warning			
Alarm content		·Tough drive function was activated.			
Detail No.	Detail name	Cause	Check method	Check result	Action
F0.1	Instantaneous power failure tough drive warning	(1) The voltage of the control circuit power supply has dropped.	Check it with the check method for [AL. 10.1].		
F0.3	Vibration tough [GF] drive warning	(1) The setting value of the machine resonance suppression filter was changed due to a machine resonance.	Check if it was changed frequently.	It was changed frequently.	Set the machine resonance suppression filter. Check the machine status if screws are loose or the like.

Alarm No.: F2		Name: Drive recorder - Miswriting warning			
Alarm content		A waveform measured by the drive recorder function was not recorded.			
Detail No.	Detail name	Cause	Check method	Check result	Action
F2.1	Drive recorder - Area writing time-out warning	(1) The Flash-ROM is malfunctioning.	Disconnect the cables except for the control circuit power supply, and then check the repeatability.	It is repeatable	Replace the driver.
F2.2	Drive recorder - Data miswriting warning	(1) Data were not written to the drive recorder area.	Check if clearing alarm history disables this alarm with setup software (MR Configurator2™)	It is not canceled.	Replace the driver.

Alarm No.: F3		Name: Oscillation detection warning			
Alarm content		· [AL. 54 Oscillation detection] can occur.			
Detail No.	Detail name	Cause	Check method	Action	Target
F3.1	Oscillation detection warning	Check it with the check method for [AL. 54.1].			

8. TROUBLESHOOTING

Alarm No.: F4		Name: Positioning warning				
Alarm content		• Target position or acceleration time constant/deceleration time constant was set out of setting range.				
Detail No.	Detail name	Cause	Check method	Check result	Action	
F4.4	Target position setting range error warning	(1) A target position was set out of setting range.	Check the setting value of the target position.	It is out of setting range.	Set the target position correctly, and cancel the warning (turn on C_ORST).	

8.6 Troubleshooting at power on

When a system error occurs at power on of the upper side, improper boot of the driver might be the cause. Check the display of the driver, and take actions according to this section.

Display	Description	Cause	Checkpoint	Action
000	The network card or driver is malfunctioning.	The network card is malfunctioning.	Replace the network card, and then check the repeatability.	Replace the network card.
		The driver is malfunctioning.	Replace the driver, and then check the repeatability.	Replace the driver.
Ab	Initialization communication with the upper side has not completed.	The setting of the axis No. is incorrect.	Check that the other driver is not assigned to the same axis No.	Set it correctly.
		Axis No. does not match with the axis No. set to the upper side.	Check the setting and axis No. of the upper side.	Set it correctly.
		An Ethernet cable was disconnected.	"Ab" is displayed in the corresponding axis and following axes.	Replace the Ethernet cable of the corresponding axis.
			Check if the connector is unplugged.	Connect it correctly.
		The IP address set in the network card and the IP address of the upper side do not match.	Check the IP address with the "AnybusIPconfig" tool or the system configuration window of Setup software (MR Configurator2™).	Set the IP address correctly.
		The power of the driver was turned off.	"Ab" is displayed in the corresponding axis and following axes.	Check the power of the driver.
		The driver is malfunctioning.	"Ab" is displayed in the corresponding axis and following axes.	Replace the driver of the corresponding axis.
The network card is malfunctioning.	"Ab" is displayed in the corresponding axis and following axes.	Replace the network card of the corresponding axis.		
b##. (Note)	The system has been in the test operation mode.	Test operation mode has been enabled.	Test operation select switch (SW1-1) is turned on.	Turn off the test operation select switch (SW1-1).
off	Operation mode for manufacturer setting is set.	Operation mode for manufacturer setting is enabled.	Check if all of the mode select switches (SW1) are on.	Set the mode select switches (SW1) correctly.

Note. ## indicates axis No.

8. TROUBLESHOOTING

8.7 Trouble which does not trigger an alarm/warning

Refer to this section and Trouble which does not trigger alarm/warning, remove the cause of the trouble.

Description	Cause	Checkpoint	Action
The servo motor does not operate.	The connection of the servo motor is incorrect.	Check the wiring of U/V/W.	Connect them correctly.
	The servo motor power cable is connected to the driver of a different axis.	Check if the encoder cable and the servo motor power cable are connected to the same driver.	Connect the encoder cable and the servo motor power cable correctly.
	An alarm or warning is occurring.	Check if an alarm or warning is occurring.	Check the contents of the alarm/warning, and remove its cause.
	The system is in the test operation mode.	Check if the test operation select switch is on (up).	Cancel the test operation mode.
	The motor-less operation is enabled.	Check the value set in [Pr. PC05].	Disable the motor-less operation.
	The torque is insufficient due to large load.	Check instantaneous torque using Setup software (MR Configurator2™) if the load exceeds the maximum torque or torque limit value.	Reduce the load or use a servo motor with a larger capacity.
	An unintended torque limit is enabled.	Check if the torque limit is enabled.	Cancel the torque limit.
	The setting value for the torque limit is incorrect.	Check if the torque limit value is "0" with [Pr. PA11], [Pr. PA12] or the setting on the upper side side.	Set it correctly.
	A machine is interfering with the servo motor.	Check if a machine is interfering.	Remove the interference.
	For a servo motor with a lock, the lock has not been released.	Check the power supply of the lock.	Turn on the lock power.
	LSP (Forward rotation stroke end) and LSN (Reverse rotation stroke end) are not on.	Check if [AL. 99] is occurring.	Turn on LSP and LSN.
	The setting of the control mode is incorrect.	Check the [Pr. PA01] setting.	Set it correctly.
	The setting of the electronic gear is incorrect.	Check the setting of the electronic gear.	Set a proper value of the electronic gear.
	The setting of point tables is incorrect.	Check the setting of the point table.	Review the setting of the point table.
	The setting of the point table command is incorrect.	Check the setting of the point table command (Target point table).	Review the setting of the point table command.
The setting of the next station position is incorrect.	Check the setting of the next station position (Target point table).	Review the setting of the next station position.	
The home position return does not start.	The setting of the homing method is incorrect.	Check the Statusword bit 13 (Homing error) in the homing mode (hm). Check the setting of the homing method.	Review the setting of the homing method.

9. OUTLINE DRAWINGS

9. OUTLINE DRAWINGS	2
9.1 Driver	2
9.2 Connector	4

9. OUTLINE DRAWINGS

9. OUTLINE DRAWINGS

9.1 Driver

(1) LECSND2-T5/LECSND2-T7/LECSND2-T8

[Unit: mm]

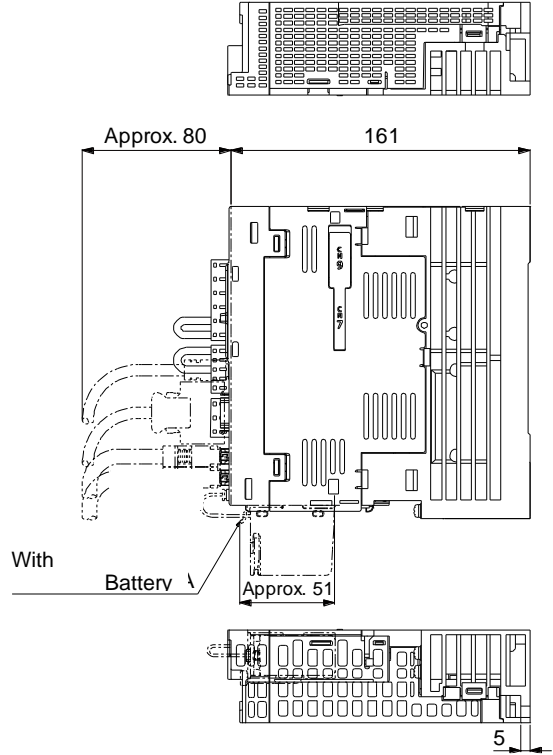
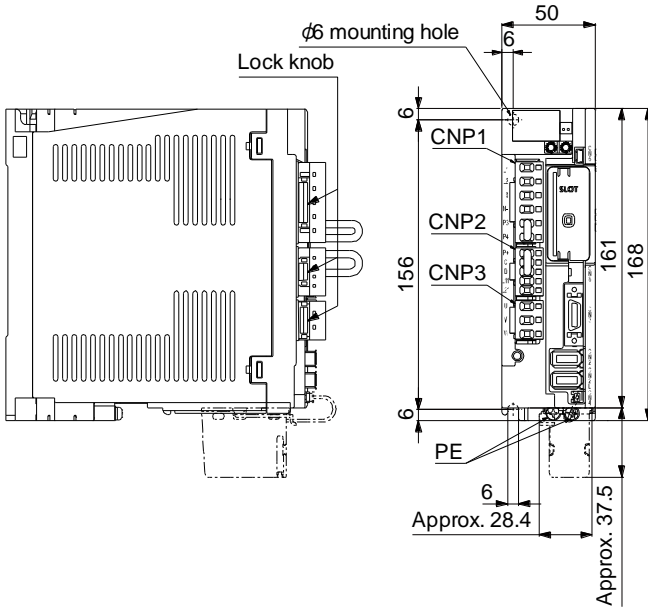

Mass: 1.0 [kg]

Mounting screw
Screw size: M5
Tightening torque: 3.24 [N·m]

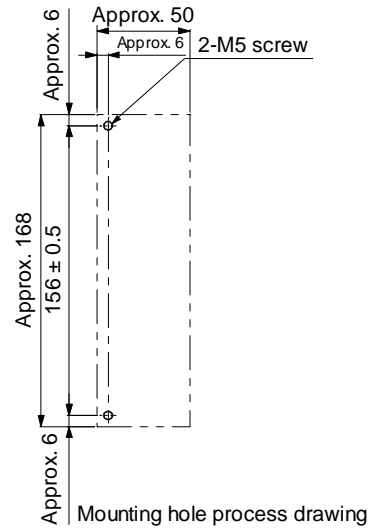
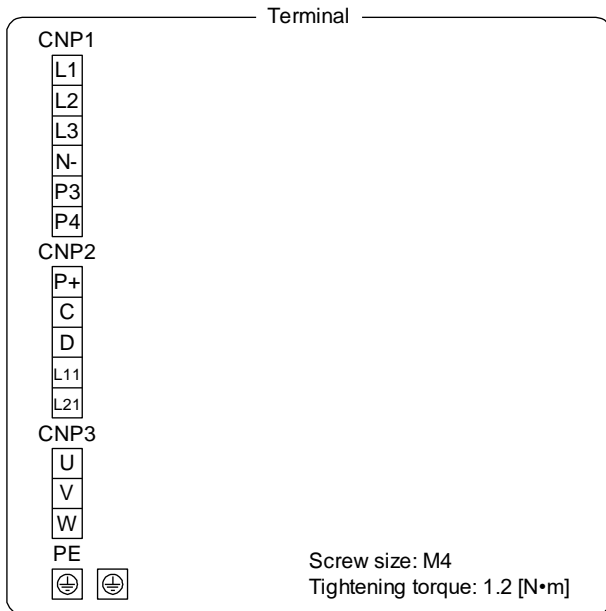

9. OUTLINE DRAWINGS

(2) LECSND2-T9

[Unit: mm]

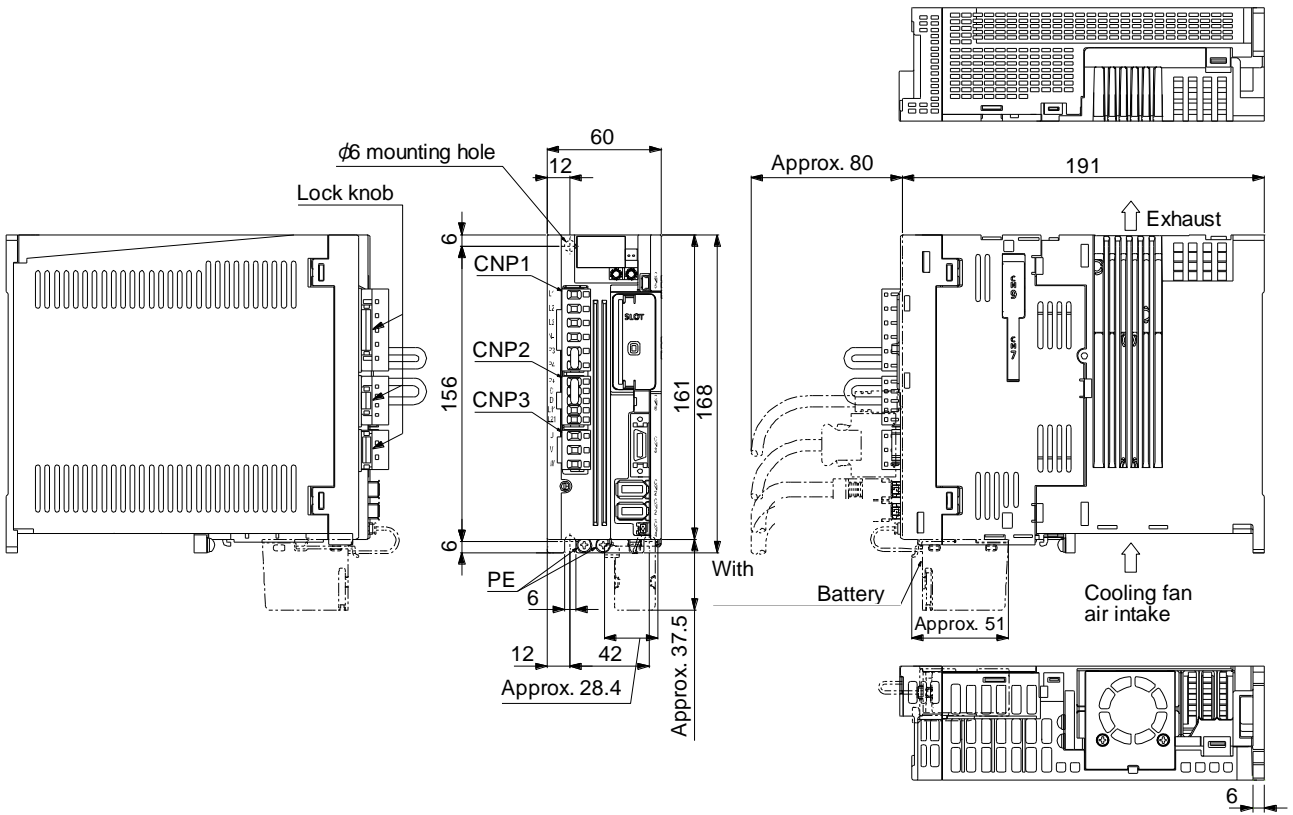

Mass: 1.4 [kg]

Mounting screw
Screw size: M5
Tightening torque: 3.24 [N·m]

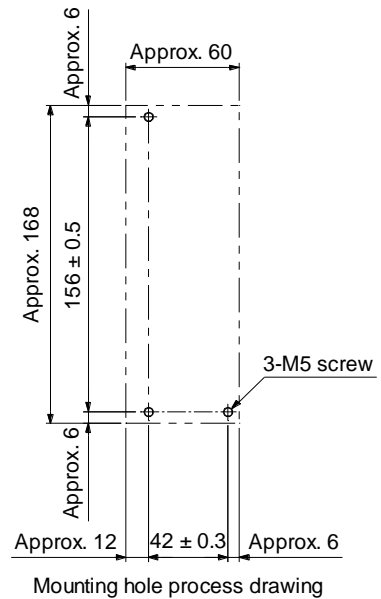
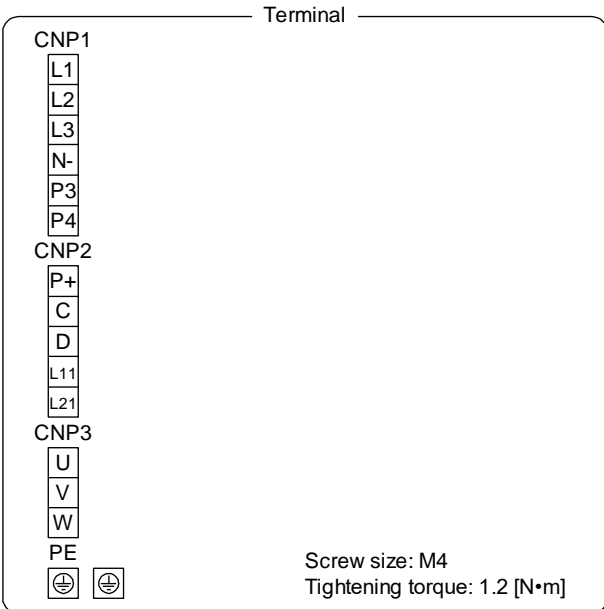

9. OUTLINE DRAWINGS

9.2 Connector (1) LE-CSNS connector

[Unit: mm]

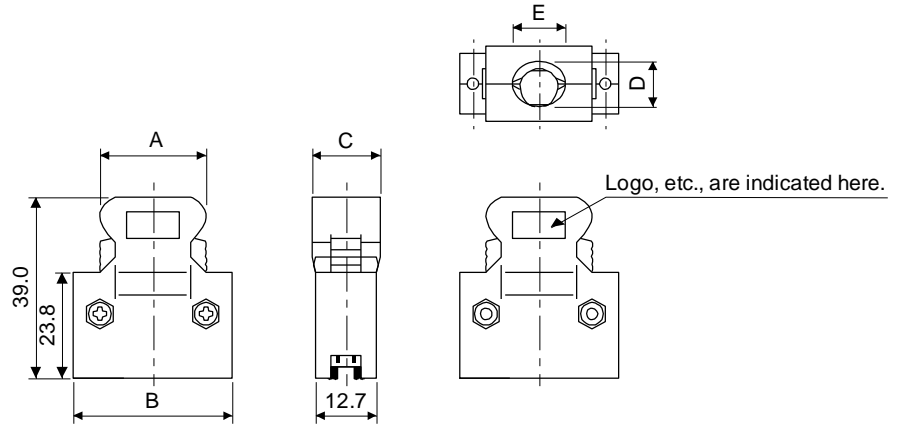

Connector	Shell kit	Each type of dimension				
		A	B	C	D	E
10120-3000PE	10320-52F0-008	22.0	33.3	14.0	10.0	12.0

Accept wire : AWG 24, 26, 28, 30

10. CHARACTERISTICS

10. CHARACTERISTICS	2
10.1 Overload protection characteristics.....	2
10.2 Power supply capacity and generated loss	3
10.3 Dynamic lock characteristics.....	5
10.3.1 Dynamic lock operation	5
10.3.2 Permissible load to motor inertia when the dynamic lock is used.....	6
10.4 Cable bending life	7
10.5 Inrush currents at power-on of main circuit and control circuit	8

10. CHARACTERISTICS

10. CHARACTERISTICS

10.1 Overload protection characteristics

An electronic thermal is built in the driver to protect the servo motor, driver and servo motor power wires from overloads.

[AL. 50 Overload 1] occurs if overload operation performed is above the electronic thermal protection curve shown in fig. 10.1 [AL. 51 Overload 2] occurs if the maximum current is applied continuously for several seconds due to machine collision, etc. Use the equipment on the left-hand side area of the continuous or broken line in the graph.

For the system where the unbalanced torque occurs, such as a vertical axis system, the unbalanced torque of the machine should be kept at 70% or less of the rated torque.

This driver has solid-state servo motor overload protection. (The servo motor overload current (full load current) is set on the basis of 120% rated current of the driver.)

The following table shows combinations of each servo motor and graph of overload protection characteristics.

The following graphs show overload protection characteristics.

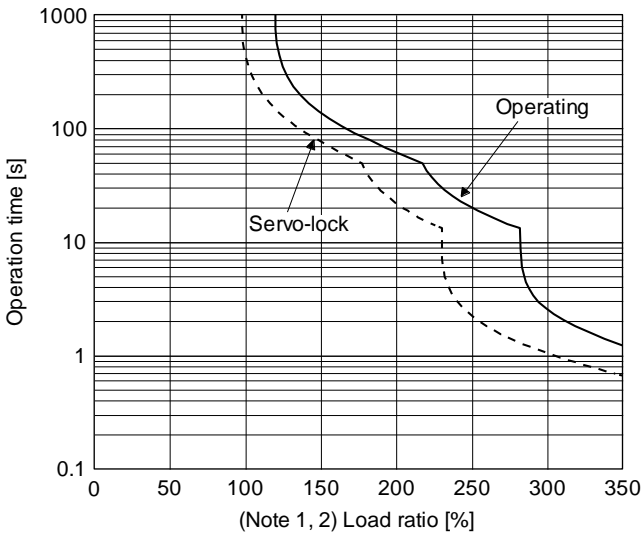

LECSND□-T5

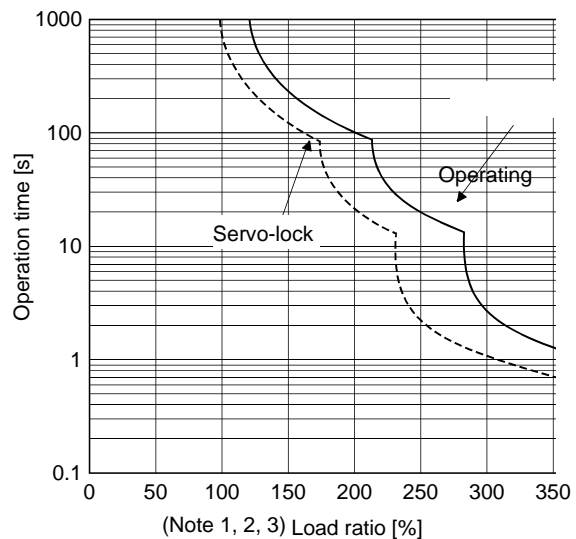

LECSND□-T7, LECSND□-T8, LECSND2-T9

Note 1. If operation that generates torque more than 100% of the rating is performed with an abnormally high frequency in a servo motor stop status (servo-lock status) or in a 50 r/min or less low-speed operation status, the driver may malfunction regardless of the electronic thermal protection.

Fig. 10.1 Electronic thermal protection characteristics

10. CHARACTERISTICS

10.2 Power supply capacity and generated loss

(1) Amount of heat generated by the driver

Table 10.1 indicates drivers' power supply capacities and losses generated under rated load. For thermal design of an enclosed type cabinet, use the values in the table in consideration for the worst operating conditions. The actual amount of generated heat will be intermediate between values at rated torque and servo-off according to the duty used during operation. When the servo motor is run at less than the rated speed, the power supply capacity will be smaller than the value in the table, but the driver's generated heat will not change.

Table 10.1 Power supply capacity and generated loss per servo motor at rated output

Driver	Servo motor	(Note 1) Power supply capacity [kVA]	(Note 2) Driver-generated heat [W]		Area required for heat dissipation [m ²]
			At rated output	With servo-off	
LECSND□-T5	100W	0.3	25	15	0.5
LECSND□-T7	200W	0.5	25	15	0.5
LECSND□-T8	400W	0.9	35	15	0.7
LECSND2-T9	750W	1.3	50	15	1.0

Note 1. Note that the power supply capacity will vary according to the power supply impedance.

2. Heat generated during regeneration is not included in the driver-generated heat.

(2) Heat dissipation area for an enclosed type cabinet

The enclosed type cabinet (hereafter called the cabinet) which will contain the driver should be designed to ensure that its temperature rise is within +10 °C at the ambient temperature of 40 °C. (With an approximately 5 °C safety margin, the system should operate within a maximum 55 °C limit.) The necessary cabinet heat dissipation area can be calculated by equation 10.1.

$$A = \frac{P}{K \cdot \Delta T} \dots\dots\dots (10.1)$$

A: Heat dissipation area [m²]

P: Loss generated in the cabinet [W]

ΔT: Difference between internal and ambient temperatures [°C]

K: Heat dissipation coefficient [5 to 6]

10. CHARACTERISTICS

When calculating the heat dissipation area with equation 10.1, assume that P is the sum of all losses generated in the cabinet. Refer to table 10.1 for heat generated by the driver. "A" indicates the effective area for heat dissipation, but if the cabinet is directly installed on an insulated wall, that extra amount must be added to the cabinet's surface area. The required heat dissipation area will vary with the conditions in the cabinet. If convection in the cabinet is poor and heat builds up, effective heat dissipation will not be possible. Therefore, arrangement of the equipment in the cabinet and the use of a cooling fan should be considered. Table 10.1 lists the cabinet dissipation area for each driver (guideline) when the driver is operated at the ambient temperature of 40 °C under rated load.

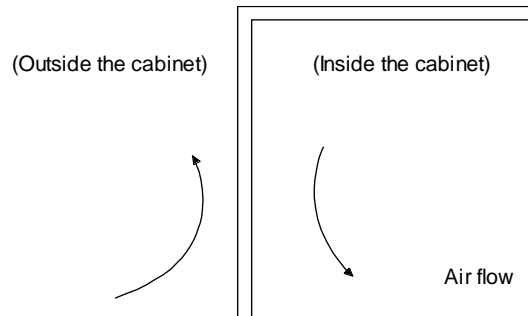

Fig. 10.2 Temperature distribution in an enclosed type cabinet

When air flows along the outer wall of the cabinet, effective heat exchange will be possible, because the temperature slope inside and outside the cabinet will be steeper.

10. CHARACTERISTICS

10.3 Dynamic lock characteristics

CAUTION

- The coasting distance is a theoretically calculated value which ignores the running load such as friction. The calculated value will be longer than the actual distance. If an enough braking distance is not provided, a moving part may crash into the stroke end, which is very dangerous. Install the anti-crash mechanism such as an air lock or an electric/mechanical stopper such as a shock absorber to reduce the shock of moving parts.

POINT

- Do not use dynamic lock to stop in a normal operation as it is the function to stop in emergency.
- For a machine operating at the recommended load to motor inertia ratio or less, the estimated number of usage times of the dynamic lock is 1000 times while the machine decelerates from the rated speed to a stop once in 10 minutes.
- Be sure to enable EM1 (Forced stop 1) after servo motor stops when using EM1 (Forced stop 1) frequently in other than emergency.
- Servo motors for LECSND□-T□ may have the different coasting distance from that of the previous model.
- The electronic dynamic lock operates in the initial state for the servo motors of 400 W or smaller capacity. The time constant "τ" for the electronic dynamic lock will be shorter than that of normal dynamic lock. Therefore, coasting distance will be longer than that of normal dynamic lock. For how to set the electronic dynamic lock, refer to [Pr. PF06] and [Pr. PF12].

10.3.1 Dynamic lock operation

(1) Calculation of coasting distance

Fig. 10.3 shows the pattern in which the servo motor comes to a stop when the dynamic lock is operated. Use equation 10.2 to calculate an approximate coasting distance to a stop. The dynamic lock time constant τ varies with the servo motor and machine operation speeds. (Refer to (2) of this section.)

A working part generally has a friction force. Therefore, actual coasting distance will be shorter than a maximum coasting distance calculated with the following equation.

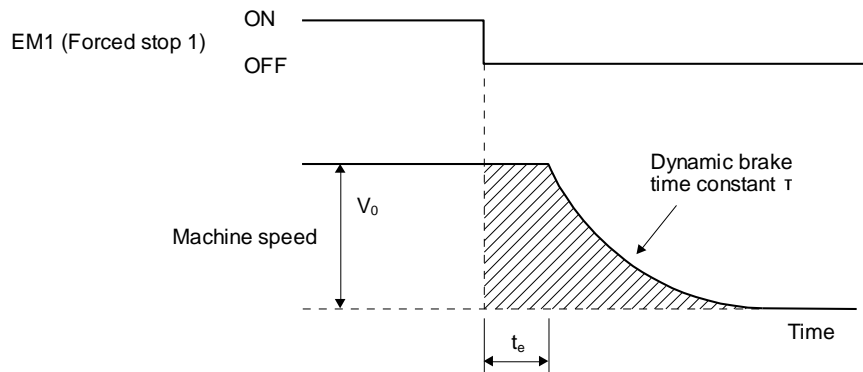

Fig. 10.3 Dynamic lock operation diagram

$$L_{\max} = \frac{V_0}{60} \cdot \left\{ t_e + \tau \left(1 + \frac{J_L}{J_M} \right) \right\} \dots \dots \dots (10.2)$$

10. CHARACTERISTICS

- L_{max} : Maximum coasting distance [mm]
 V_0 : Machine's fast feed speed [mm/min]
 J_M : Moment of inertia of the servo motor [$\times 10^{-4}$ kg·m²]
 J_L : Load moment of inertia converted into equivalent value on servo motor shaft [$\times 10^{-4}$ kg·m²]
 τ : Dynamic lock time constant [s]
 t_e : Delay time of control section [s]

There is internal relay delay time of about 10 ms.

(2) Dynamic lock time constant

The following shows necessary dynamic lock time constant τ for equation 10.2.

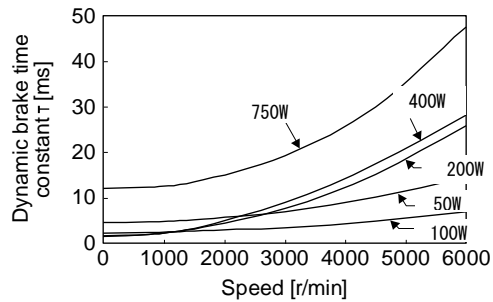

10.3.2 Permissible load to motor inertia when the dynamic lock is used

Use the dynamic lock under the load to motor inertia ratio indicated in the following table. If the load inertia moment is higher than this value, the dynamic lock may burn. If the load to motor inertia ratio exceeds the indicated value, contact your local sales office.

The values of the permissible load to motor inertia ratio in the table are the values at the maximum rotation speed of the servo motor. The value in the parenthesis shows the value at the rated speed.

Servo motor	Permissible load to motor inertia ratio [multiplier]
100W	30
200W	
400W	
750W	

10. CHARACTERISTICS

10.4 Cable bending life

The bending life of the cables is shown below. This graph calculated values. Since they are not guaranteed values, provide a little allowance for these values. The minimum bending radius : Min. 45mm.

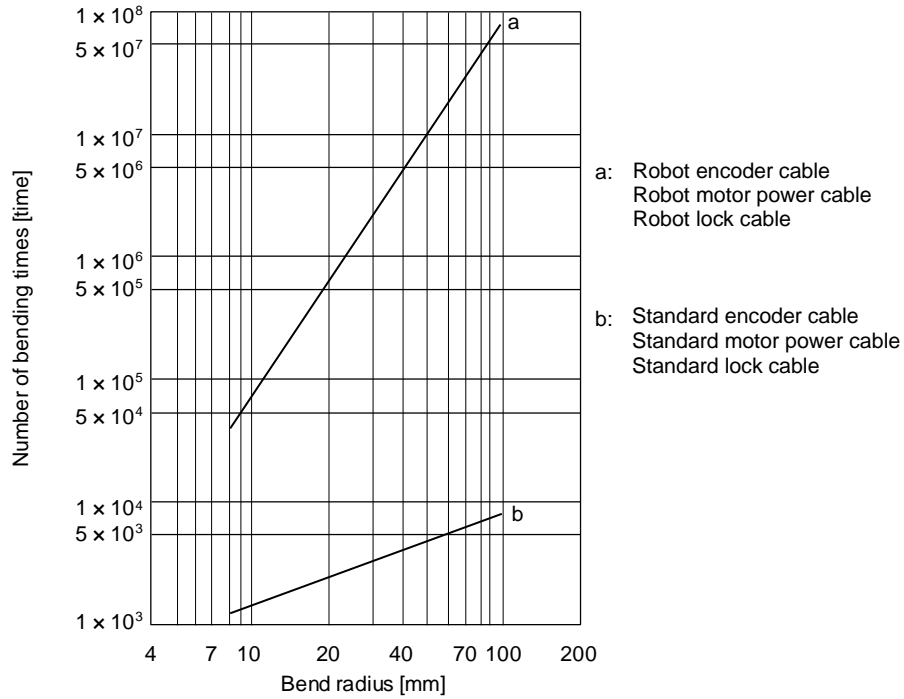

10. CHARACTERISTICS

10.5 Inrush currents at power-on of main circuit and control circuit

POINT
<ul style="list-style-type: none"> ● For a driver of LECSND□-T8 or less, the inrush current values can change depending on frequency of turning on/off the power and ambient temperature.

Since large inrush currents flow in the power supplies, always use molded-case circuit breakers and magnetic contactors. (Refer to section 11.6.)

When circuit protectors are used, it is recommended that the inertia delay type, which is not tripped by an inrush current, be used.

- LECSND2-T□

The following shows the inrush currents (reference data) that will flow when 240 V AC servo amplifier) is applied. Even when you use a 1-phase 200 V AC power supply with LECSND2-T5 to LECSND2-T9, the inrush currents of the main circuit power supply is the same.

Driver	Inrush currents (A_{0-P})	
	Main circuit power supply (L1, L2, and L3)	Control circuit power supply (L11 and L21)
LECSND2-T5/ LECSND2-T7/ LECSND2-T8	30 A (attenuated to approx. 3 A in 20 ms)	20 A to 30 A (attenuated to approx. 1 A in 20 ms)
LECSND2-T9	34 A (attenuated to approx. 7 A in 20 ms)	

11. OPTIONS AND PERIPHERAL EQUIPMENT

11. OPTIONS AND PERIPHERAL EQUIPMENT	2
11.1 Cable/connector sets	2
11.1.1 Combinations of cable/connector sets	3
11.1.2 STO cable.....	6
11.1.3 Encoder cable/connector sets.....	7
11.1.4 Motor cables	9
11.1.5 Lock cables	10
11.2 Regenerative options	11
11.2.1 Combination and regenerative power	11
11.2.2 Parameter setting	11
11.2.3 Selection of regenerative option.....	12
11.2.4 Dimensions	13
11.3 Setup software (MR Configurator2™)	15
11.3.1 Specifications.....	15
11.3.2 System configuration	16
11.3.3 Precautions for using USB communication function.....	17
11.4 Battery.....	18
11.5 Selection example of wires	19
11.6 Molded-case circuit breakers, fuses, magnetic contactors (recommended)	21
11.7 Relay (recommended)	21
11.8 Noise reduction techniques	22
11.9 Earth-leakage current breaker	30
11.10 EMC filter (recommended).....	32

11. OPTIONS AND PERIPHERAL EQUIPMENT

11. OPTIONS AND PERIPHERAL EQUIPMENT

 WARNING	<ul style="list-style-type: none">● Before connecting any option or peripheral equipment, turn off the power and wait for 15 minutes or more until the charge lamp turns off. Then, confirm that the voltage between P+ and N- is safe with a voltage tester and others. Otherwise, an electric shock may occur. In addition, when confirming whether the charge lamp is off or not, always confirm it from the front of the driver.
--	--

 CAUTION	<ul style="list-style-type: none">● Use the specified peripheral equipment and options to prevent a malfunction or a fire.
--	--

POINT
<ul style="list-style-type: none">● We recommend using HIV wires to wire the drivers, options, and peripheral equipment. Therefore, the recommended wire sizes may differ from those used for the previous drivers.

11.1 Cable/connector sets

POINT
<ul style="list-style-type: none">● The IP rating indicated for cables and connectors is their protection against ingress of dust and raindrops when they are connected to a driver or servo motor. If the IP rating of the cable, connector, driver and servo motor vary, the overall IP rating depends on the lowest IP rating of all components.

Please purchase the cable and connector options indicated in this section.



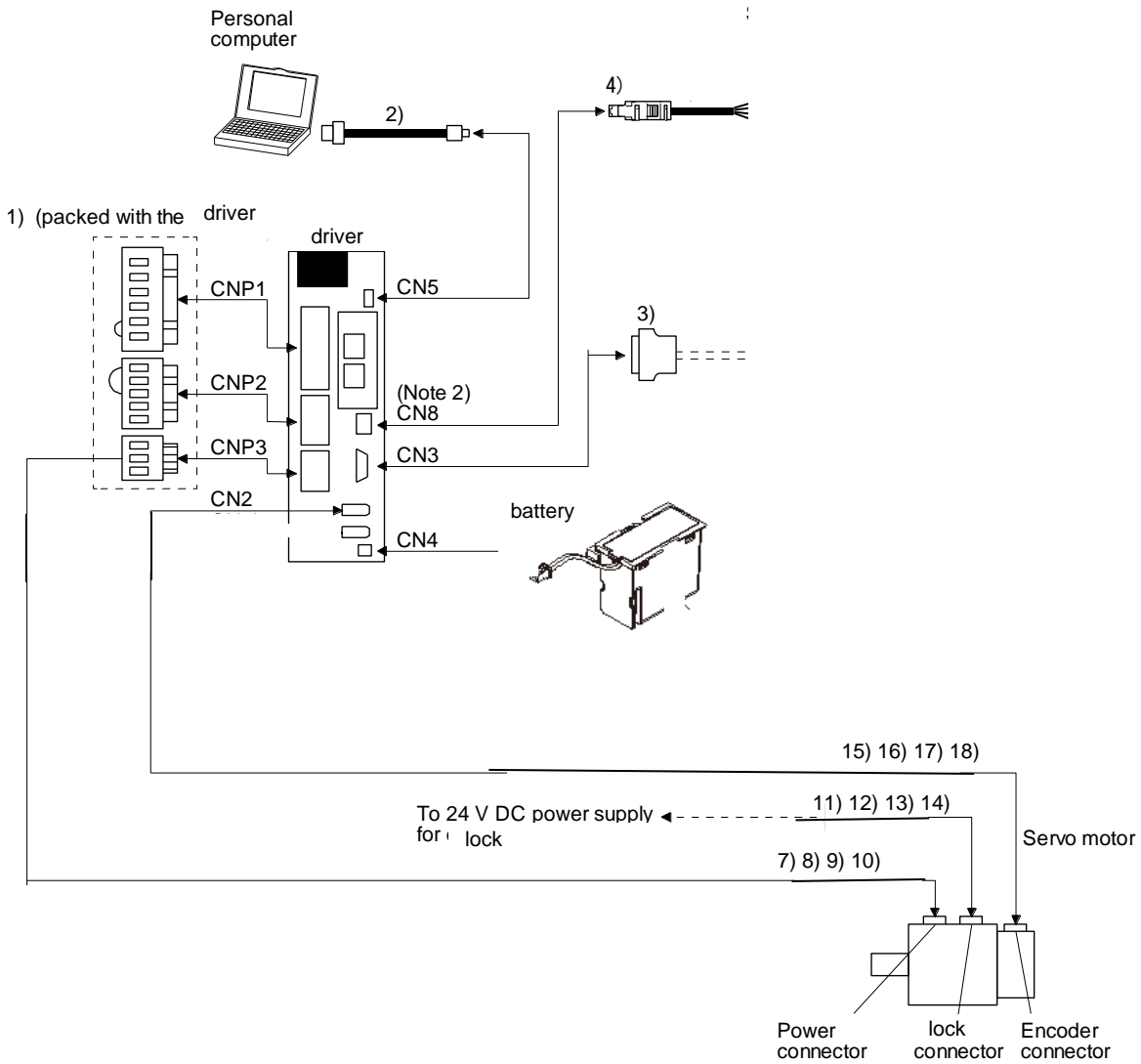

11. OPTIONS AND PERIPHERAL EQUIPMENT

11.1.1 Combinations of cable/connector sets For LECSND□-T□ driver

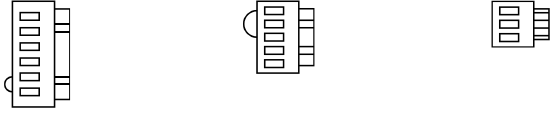
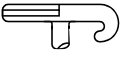

Note 2. When not using the STO function, attach the short-circuit connector (5) came with a driver.

11. OPTIONS AND PERIPHERAL EQUIPMENT

No.	Product name	Model	Description	Application
1)	Driver power connector set		 <p>CNP1 Connector: K05A01490252 (MITSUBISHI ELECTRIC SYSTEM & SERVICE CO., LTD)</p> <p>CNP2 Connector: K05A01490253 (MITSUBISHI ELECTRIC SYSTEM & SERVICE CO., LTD)</p> <p>CNP3 Connector: K05A01490254 (MITSUBISHI ELECTRIC SYSTEM & SERVICE CO., LTD)</p> <p>Applicable wire size: 0.8 mm² to 2.1 mm² (AWG 18 to 14) Insulator OD: to 3.9 mm</p>  <p>Open tool (Attached to the network card slot cover)</p>	Supplied with drivers
2)	USB cable	LEC-MR-J3USB Cable length: 3 m	<p>CN5 connector mini-B connector (5 pins)</p> <p>Personal computer connector A connector</p> 	For connection with PC-AT compatible personal computer
3)	Connector set	LE-CSNS	 <p>Connector: 10120-3000PE Shell kit: 10320-52F0-008 (Sumitomo 3M Limited or equivalent)</p>	
4)	STO cable	LEC-MR-D05UDL3M	<p>Connector set: 2069250-1 (TE Connectivity)</p> 	Connection cable for the CN8 connector
5)	Short-circuit connector			Supplied with driver

11. OPTIONS AND PERIPHERAL EQUIPMENT

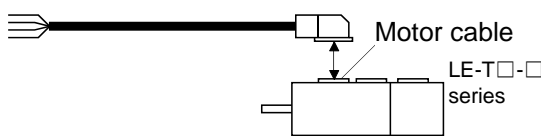
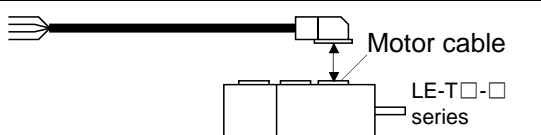
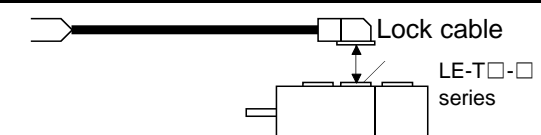
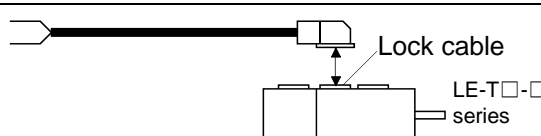
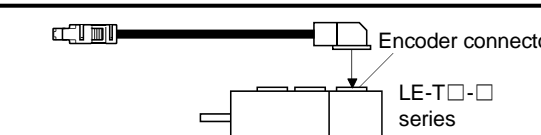
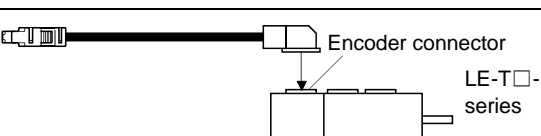
No.	Product name	Model	Description	Application
7)	Motor power supply cable	LE-CSM-S□A Cable length: 2 · 5 · 10m	 <p>Motor cable LE-T□-□ series</p>	IP65 Load side lead
8)	Motor power supply cable	LE-CSM-R□A Cable length: 2 · 5 · 10m		IP65 Load side lead Robot cable
9)	Motor power supply cable	LE-CSM-S□B Cable length: 2 · 5 · 10m	 <p>Motor cable LE-T□-□ series</p>	IP65 Opposite-to-load side lead
10)	Motor power supply cable	LE-CSM-R□B Cable length: 2 · 5 · 10m		IP65 Opposite-to-load side lead Robot cable
11)	Lock cable	LE-CSB-S□A Cable length: 2 · 5 · 10m	 <p>Lock cable LE-T□-□ series</p>	IP65 Load side lead
12)	Lock cable	LE-CSB-R□A Cable length: 2 · 5 · 10m		IP65 Load side lead Robot cable
13)	Lock cable	LE-CSB-S□B Cable length: 2 · 5 · 10m	 <p>Lock cable LE-T□-□ series</p>	IP65 Opposite-to-load side lead
14)	Lock cable	LE-CSB-R□B Cable length: 2 · 5 · 10m		IP65 Opposite-to-load side lead Robot cable
15)	Encoder cable	LE-CSE-S□A Cable length: 2 · 5 · 10m	 <p>Encoder connector LE-T□-□ series</p>	IP65 Load side lead
16)	Encoder cable	LE-CSE-R□A Cable length: 2 · 5 · 10m		IP65 Load side lead Robot cable
17)	Encoder cable	LE-CSE-S□B Cable length: 2 · 5 · 10m	 <p>Encoder connector LE-T□-□ series</p>	IP65 Opposite-to-load side lead
18)	Encoder cable	LE-CSE-R□B Cable length: 2 · 5 · 10m		IP65 Opposite-to-load side lead Robot cable

11. OPTIONS AND PERIPHERAL EQUIPMENT

11.1.2 STO cable

This cable is for connecting an external device to the CN8 connector.

Cable model	Cable length	Application
LEC-MR-D05UDL3M	3 m	Connection cable for the CN8 connector

(1) Configuration diagram

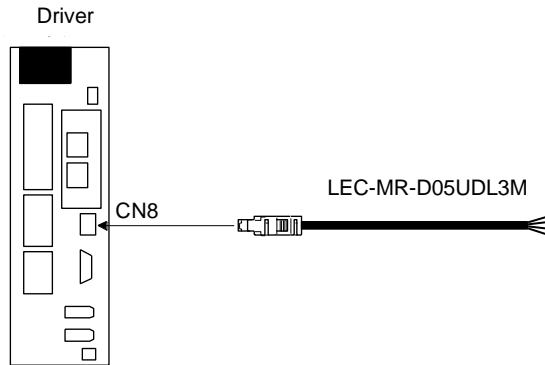

(2) Internal wiring diagram

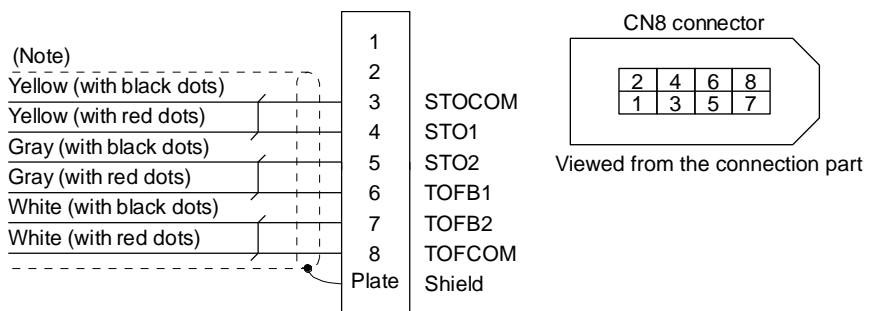

Note. Do not use the two core wires with orange insulator (with red or black dots).

11. OPTIONS AND PERIPHERAL EQUIPMENT

11.1.3 Encoder cable/connector sets

(1) LE-CSE-□□A · LE-CSE-□□B

These cables are encoder cables for the LE-□-□ series servo motors. The numerals in the Cable Length field of the table are the symbols entered in the □ part of the cable model. The cables of the lengths with the symbols are available.

Cable model	Cable length			Protective structure	Flex life	Application
	2m	5m	10m			
LE-CSE-S□A	2	5	A	IP65	Standard	For LE-□-□ servo motor Axis side lead
LE-CSE-R□A	2	5	A	IP65	Robot cable	
LE-CSE-S□B	2	5	A	IP65	Standard	For LE-□-□ servo motor Counter axis side lead
LE-CSE-R□B	2	5	A	IP65	Robot cable	

(a) Connection of driver and servo motor

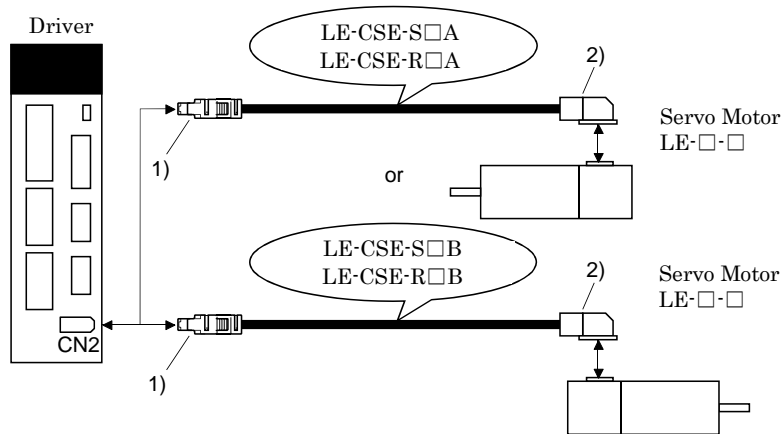

Cable model	1) For CN2 connector	2) For encoder connector
LE-CSE-S□A	Receptacle: 36210-0100PL Shell kit: 36310-3200-008 (Sumitomo 3M Limited)	Connector: 1674320-1 Crimping tool for ground clip: 1596970-1 Crimping tool for receptacle contact: 1596847-1 (Tyco Electronics)
LE-CSE-R□A	(Note) Signal layout 	(Note) Signal layout
LE-CSE-S□B	(Note) Signal layout 	(Note) Signal layout
LE-CSE-R□B	Note. Keep open the pins shown with . Especially, pin 10 is provided for manufacturer adjustment. If it is connected with any other pin, the driver cannot operate normally.	Note. Keep open the pin shown with an .

11. OPTIONS AND PERIPHERAL EQUIPMENT

(b) Cable internal wiring diagram

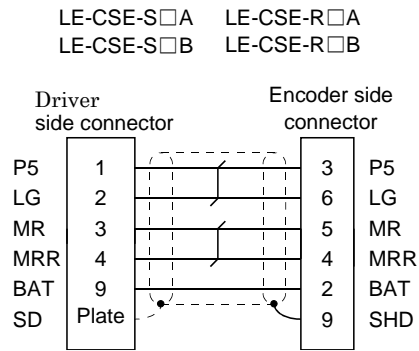

11. OPTIONS AND PERIPHERAL EQUIPMENT

11.1.4 Motor cables

These cables are motor power supply cables for the LE-□-□ series servo motors. The numerals in the Cable length field of the table are the symbols entered in the □ part of the cable model. The cables of the lengths with the symbols are available.

Cable model	Cable length			IP rating	Cable type	Application
	2m	5m	10m			
LE-CSM-S□A	2	5	A	IP65	Standard	For LE-□-□ servo motor Axis side lead
LE-CSM-S□B	2	5	A	IP65	Standard	For LE-□-□ servo motor Counter axis side lead
LE-CSM-R□A	2	5	A	IP65	Robot cable	For LE-□-□ servo motor Axis side lead
LE-CSM-R□B	2	5	A	IP65	Robot cable	For LE-□-□ servo motor Counter axis side lead

(1) Connection of driver and servo motor

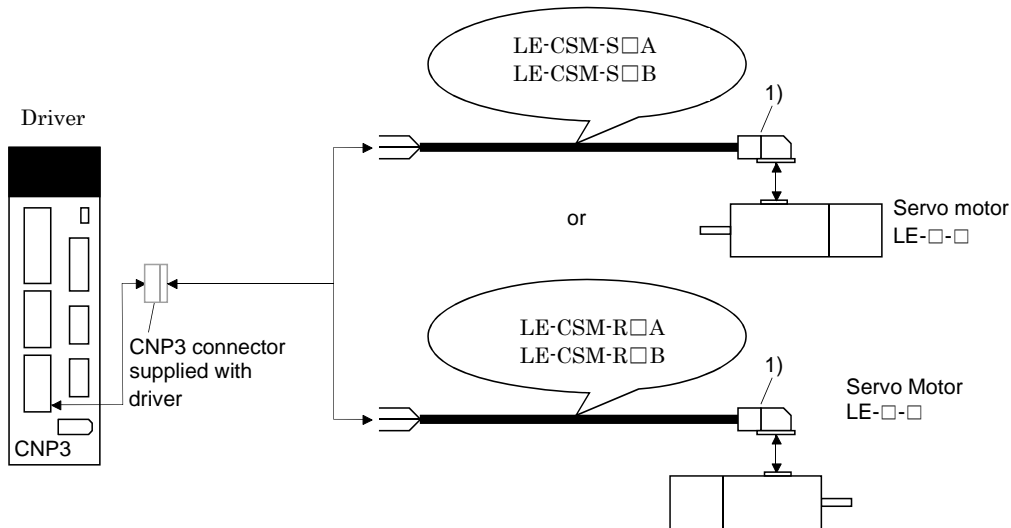

Cable model	1) For motor power supply connector	
LE-CSM-S□A	Connector: JN4FT04SJ1-R Hood, socket insulator Bushing, ground nut Contact: ST-TMH-S-C1B-100-(A534G) Crimping tool: CT160-3-TMH5B (Japan Aviation Electronics Industry)	Signal layout View seen from wiring side.
LE-CSM-S□B		
LE-CSM-R□A		
LE-CSM-R□B		

(2) Internal wiring diagram

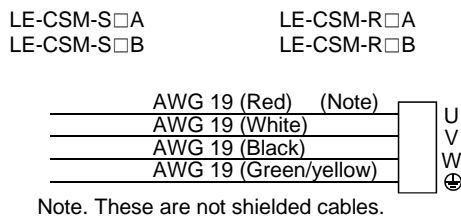

11. OPTIONS AND PERIPHERAL EQUIPMENT

11.1.5 Lock cables

These cables are lock cables for the LE-□-□ series servo motors. The numerals in the Cable length field of the table are the symbols entered in the □ part of the cable model. The cables of the lengths with the symbols are available.

Cable model	Cable length			Protective structure	Flex life	Application
	2m	5m	10m			
LE-CSB-S□A	2	5	A	IP65	Standard	For LE-□-□ servo motor Axis side lead
LE-CSB-S□B	2	5	A	IP65	Standard	For LE-□-□ servo motor Counter axis side lead
LE-CSB-R□A	2	5	A	IP65	Robot cable	For LE-□-□ servo motor Axis side lead
LE-CSB-R□B	2	5	A	IP65	Robot cable	For LE-□-□ servo motor Counter axis side lead

(1) Connection of power supply for lock and servo motor

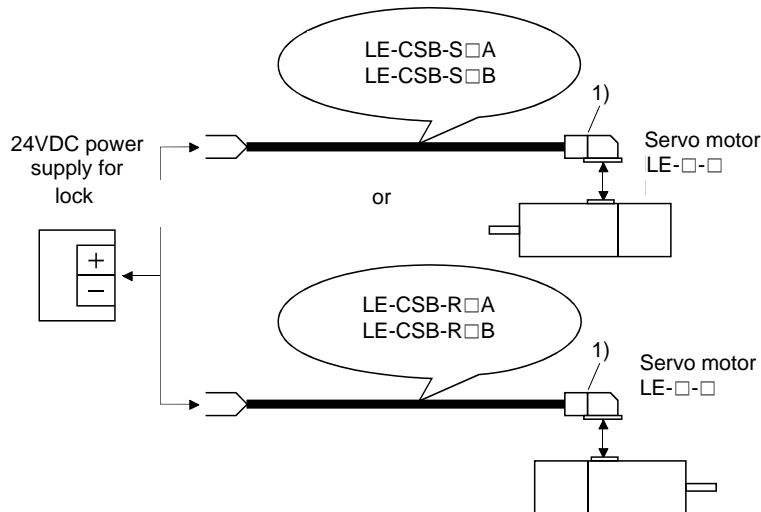

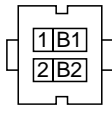
Cable model	1) For lock connector	
LE-CSB-S□A	Connector: JN4FT02SJ1-R Hood, socket insulator Bushing, ground nut Contact: ST-TMH-S-C1B-100-(A534G) Crimping tool: CT160-3-TMH5B (Japan Aviation Electronics Industry)	Signal layout  View seen from wiring side.
LE-CSB-S□B		
LE-CSB-R□A		
LE-CSB-R□B		

(2) Internal wiring diagram

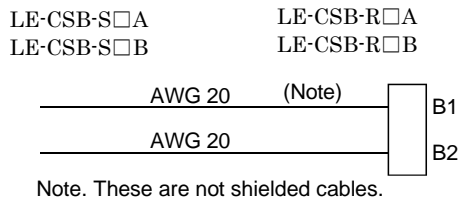

11. OPTIONS AND PERIPHERAL EQUIPMENT

11.2 Regenerative options



CAUTION

● Do not use drivers with regenerative options other than the combinations specified below. Otherwise, it may cause a fire.

11.2.1 Combination and regenerative power

The power values in the table are resistor-generated powers and not rated powers.

Driver	Regenerative power [W]			
	Built-in regenerative resistor	LEC-MR-RB-032 [40 Ω]	LEC-MR-RB-12 [40 Ω]	LEC-MR-RB-32 [40Ω]
LECSND2-T5		30		
LECSND2-T7	10	30	100	
LECSND2-T8	10	30	100	
LECSND2-T9	20	30	100	300

(Note: The shaded areas cannot be used.)

11.2.2 Parameter setting

Set [Pr. PA02] according to the option to be used.

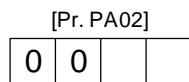

Regenerative option selection

00: Regenerative option is not used.

- For driver of 100 W, regenerative resistor is not used.

- For driver of 200 W to 750W, built-in regenerative resistor is used.

02: LEC-MR-RB-032

03: LEC-MR-RB-12

04: LEC-MR-RB-32

11. OPTIONS AND PERIPHERAL EQUIPMENT

11.2.3 Selection of regenerative option

POINT

- | |
|--|
| ● For the wire sizes used for wiring, refer to section 11.5. |
|--|

The regenerative option generates heat of 100 °C higher than the ambient temperature. Fully consider heat dissipation, installation position, wires used, etc. before installing the option. For wiring, use flame-resistant wires or make the wires flame-resistant and keep them away from the regenerative option. Always use twisted cables of max. 5 m length for connection with the driver.

(1) LECSND2-T□

Always remove the wiring from across P+ to D and fit the regenerative option across P+ to C. G3 and G4 are thermal sensor's terminals. Between G3 and G4 is opened when the regenerative option overheats abnormally.

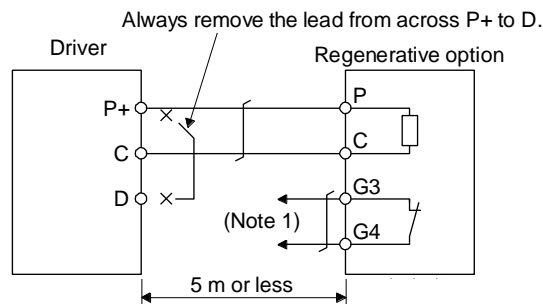

Note 1. Make up a sequence which will switch off the magnetic contactor when abnormal heating occurs.

G3-G4 contact specifications

Maximum voltage: 120 V AC/DC

Maximum current: 0.5 A/4.8 V DC

Maximum capacity: 2.4 VA

11. OPTIONS AND PERIPHERAL EQUIPMENT

11.2.4 Dimensions (1) LEC-MR-RB-12

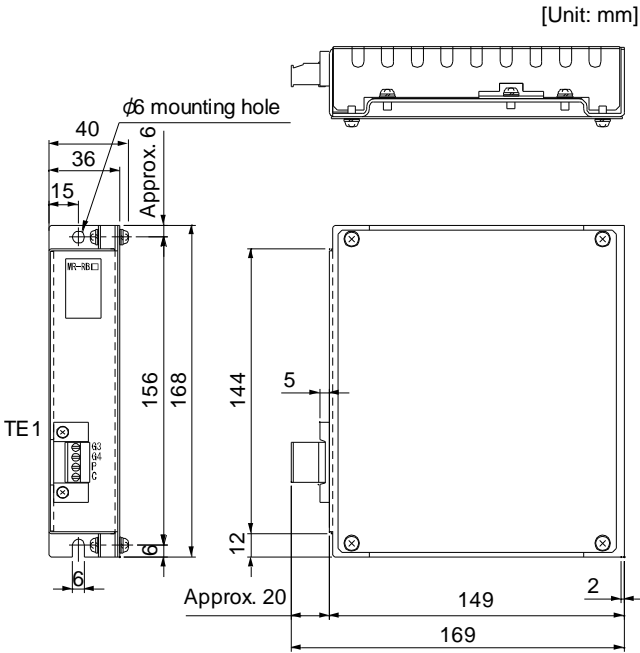

• TE1 terminal

G3
G4
P
C

Applicable wire size: 0.2 mm² to 2.5 mm² (AWG 14 to 12)
Tightening torque: 0.5 to 0.6 [N•m]

• Mounting screw
Screw size: M5
Tightening torque: 3.24 [N•m]

Mass: 1.1 [kg]

(2) LEC-MR-RB-32

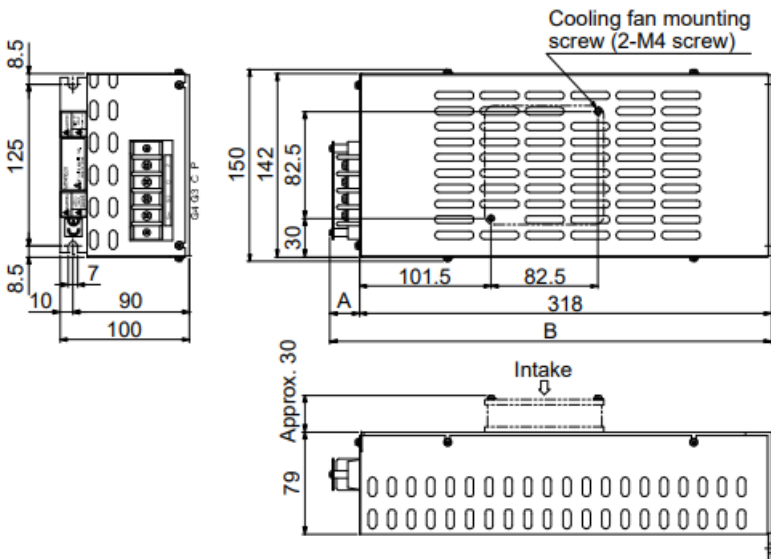

• Terminal block

P
C
G3
G4

Terminal screw size: M4
Tightening torque: 1.2 [N•m]

• Mounting screw
Screw size: M5
Tightening torque: 5.4 [N•m]

Mass: 2.9 [kg]

11. OPTIONS AND PERIPHERAL EQUIPMENT

(3) LEC-MR-RB-032

[Unit: mm]

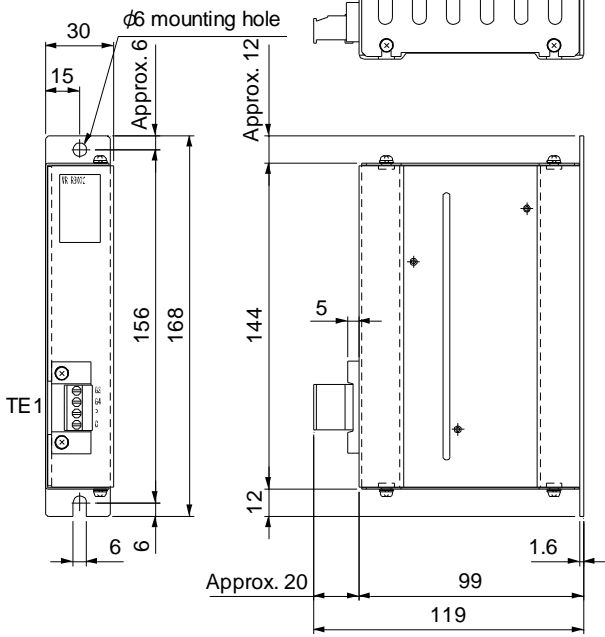

• TE1 terminal

G3
G4
P
C

Applicable wire size: 0.2 mm² to 2.5 mm²
(AWG 24 to 12)

Tightening torque: 0.5 to 0.6 [N•m]

• Mounting screw

Screw size: M5

Tightening torque: 3.24 [N•m]

Mass: 0.5 [kg]

11. OPTIONS AND PERIPHERAL EQUIPMENT

11.3 Setup software (MR Configurator2™)

Setup software (MR Configurator2™) (LEC-MRC2□) uses the communication function of the driver to perform parameter setting changes, graph display, test operation, etc. on a personal computer. When setup software (MR Configurator2™) is used, the selection of the model of LECSND□-T□ is needed. Please select 'MR-J4-TM' by "Model" - "New" - "Project".

11.3.1 Specifications

Item	Description
Project	Create/read/save/delete project, system setting, and print
Parameter	Parameter setting
Monitor	Display all, I/O monitor, graph, and ABS data display
Diagnosis	Alarm display, alarm onset data, drive recorder, no motor rotation, system configuration, life diagnosis, and machine diagnosis
Test operation	JOG operation (Note 1), positioning operation, motor-less operation (Note), DO forced output, and program operation
Adjustment	One-touch tuning, tuning, and machine analyzer
Others	Servo assistant, parameter setting range update, machine unit conversion setting, and help display

11. OPTIONS AND PERIPHERAL EQUIPMENT

11.3.2 System configuration

(1) Components

To use this setup software, the following components are required in addition to the driver and servo motor.

Equipment		Set up software(MR Configurator2™) LEC-MRC2E
Personal computer (Note 1, 2, 3, 4 5, 6, 7, 8, 9)	OS	Microsoft® Windows® 10 Edition, Microsoft® Windows® 10 Enterprise, Microsoft® Windows® 10 Pro, Microsoft® Windows® 10 Home, Microsoft® Windows® 8.1 Enterprise Microsoft® Windows® 8.1 Pro Microsoft® Windows® 8.1 Microsoft® Windows® 8 Enterprise, Microsoft® Windows® 8 Pro, Microsoft® Windows® 8, Microsoft® Windows® 7 Ultimate Microsoft® Windows® 7 Enterprise Microsoft® Windows® 7 Professional Microsoft® Windows® 7 Home Premium Microsoft® Windows® 7 Starter Microsoft® Windows Vista® Ultimate Microsoft® Windows Vista® Enterprise Microsoft® Windows Vista® Business Microsoft® Windows Vista® Home Premium Microsoft® Windows Vista® Home Basic Microsoft® Windows® XP Professional, Service Pack2 or later Microsoft® Windows® XP Home Edition, Service Pack2 or later IBM PC/AT compatible PC
	Hard Disk	1GB or more of free space
Display		One whose resolution is 1024×768 or more and that can provide a high color (16 bit) display. Connectable with the above personal computer.
Keyboard		Connectable with the above personal computer.
Mouse		Connectable with the above personal computer.
Printer		Connectable with the above personal computer.
USB cable0 (Note 10)		LEC-MR-J3USB

Note 1. Using a PC for setting Windows® 10, upgrade to version 1.52E.

Using a PC for setting Windows® 8.1, upgrade to version 1.25B.

Using a PC for setting Windows® 8, upgrade to version 1.20W.

Refer to Mitsubishi Electric Corporation's website for version upgrade information.

2. Windows® and Windows Vista® is the registered trademarks of Microsoft Corporation in the United States and other countries.

3. On some personal computers, set up software (MR Configurator2™) may not run properly.

4. The following functions cannot be used. If any of the following functions is used, this product may not operate normally.

- Start of application in Windows® compatible mode.
- Fast User Switching.
- Remote Desktop.
- Windows XP Mode.
- Windows Touch or Touch.
- Modern UI
- Client Hyper-V
- Tablet Mode
- Virtual desktop
- Does not support 64-bit Operating System, except for Microsoft® Windows® 7 or later.

11. OPTIONS AND PERIPHERAL EQUIPMENT

5. Multi-display is set, the screen of this product may not operate normally.
6. The size of the text or other items on the screen is not changed to the specified value (96DPI, 100%, 9pt, etc.), the screen of this product may not operate normally.
7. Changed the resolution of the screen during operating, the screen of this product may not operate normally.
8. Please use by "Standard User", "Administrator" in Windows Vista® or later.
9. If .NET Framework 3.5 (including .NET 2.0 and 3.0) have been disabled in Windows® 7 or later, it is necessary to enable it.
10. Order USB cable separately.

This cable is shared with Set up software (MR Configurator™ : LEC-MR-SETUP221E).

(2) Connection with driver

For use of USB

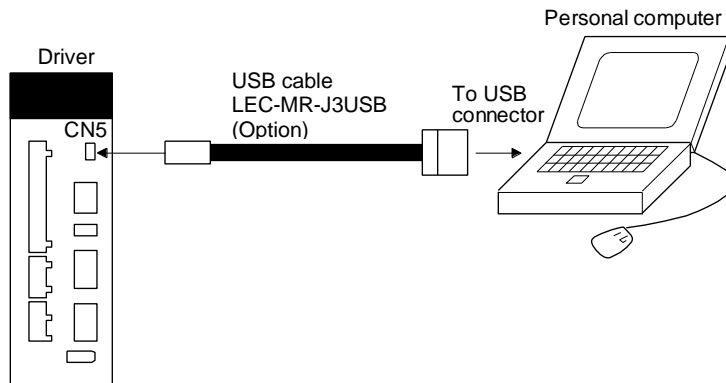

11.3.3 Precautions for using USB communication function

Note the following to prevent an electric shock and malfunction of the driver.

(1) Power connection of personal computers

Connect your personal computer with the following procedures.

(a) When you use a personal computer with AC power supply

- 1) When using a personal computer with a three-core power plug or power plug with grounding wire, use a three-pin socket or ground the grounding wire.
- 2) When your personal computer has two-core plug and has no grounding wire, connect the personal computer to the driver with the following procedures.
 - a) Disconnect the power plug of the personal computer from an AC power socket.
 - b) Check that the power plug was disconnected and connect the device to the driver.
 - c) Connect the power plug of the personal computer to the AC power socket.

(b) When you use a personal computer with battery

You can use as it is.

(2) Connection with other devices using driver communication function

When the driver is charged with electricity due to connection with a personal computer and the charged driver is connected with other devices, the driver or the connected devices may malfunction. Connect the driver and other devices with the following procedures.

- (a) Shut off the power of the device for connecting with the driver.
- (b) Shut off the power of the driver which was connected with the personal computer and check the charge lamp is off.
- (c) Connect the device with the driver.
- (d) Turn on the power of the driver and the device.

11. OPTIONS AND PERIPHERAL EQUIPMENT

11.4 Battery

POINT
● Refer to appendix 2 and 3 for battery transportation and the new EU Battery Directive.

Please purchase replacement battery from Mitsubishi Electric Corporation.

(1) Purpose of use for MR-BAT6V1SET-A

This battery is used to construct an absolute position detection system. Refer to section 12 for the fitting method, etc.

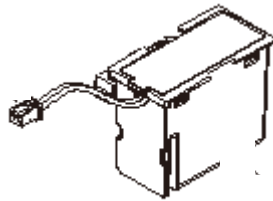

(2) Year and month of manufacture of battery

The year and month of manufacture of MR-BAT6V1SET-A have been described to the rating plate.

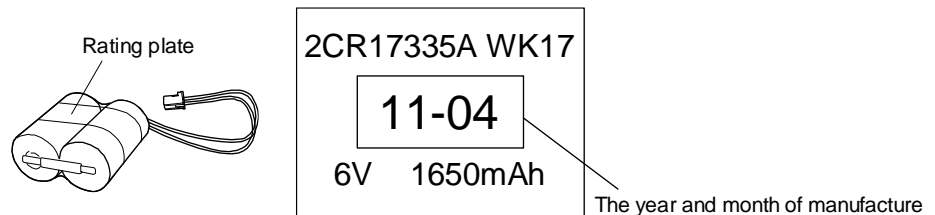

11. OPTIONS AND PERIPHERAL EQUIPMENT

11.5 Selection example of wires

POINT
<ul style="list-style-type: none"> ● To comply with the UL/CSA standard, use the wires shown in appendix 4 for wiring. To comply with other standards, use a wire that is complied with each standard. ● Selection conditions of wire size is as follows. <ul style="list-style-type: none"> Construction condition: One wire is constructed in the air. Wire length: 30 m or less

The following diagram shows the wires used for wiring. Use the wires given in this section or equivalent.

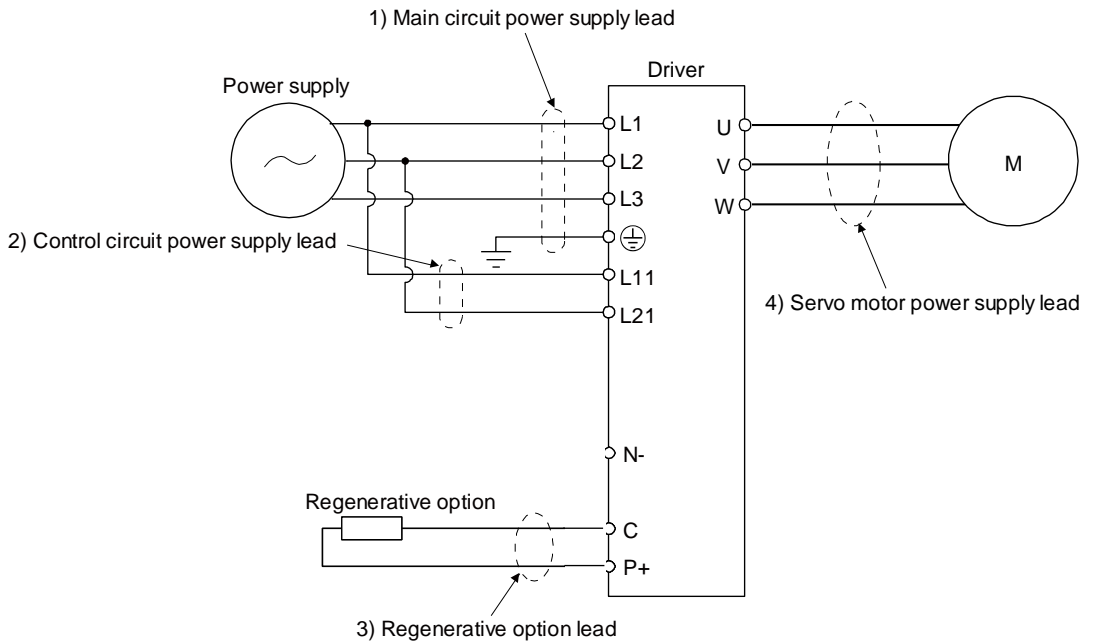

(1) Example of selecting the wire sizes

Use the 600 V Grade heat-resistant polyvinyl chloride insulated wire (HIV wire) for wiring. The following shows the wire size selection example.

Table 11.1 Wire size selection example (HIV wire)

Driver	Wire [mm ²]						
	L ₁ · L ₂ · L ₃ · ⊕	(Note 1) L ₁₁ · L ₂₁	(Note 2) U · V · W · ⊕		P · C	(Note 3) B ₁ · B ₂	
			10m or less	Extension cable		10m or less	Extension cable
LECSND□-T5	2(AWG14)	1.25(AWG16)	0.75(AWG18)	1.25(AWG16)	2(AWG14)	0.5(AWG20)	1.25(AWG16)
LECSND□-T7							
LECSND□-T8							
LECSND2-T9							

Note1. Use 2 mm² (AWG14) to comply with IEC/EN/UL/CSA standards.

Note2. Use 2 mm² (AWG14) to comply with IEC/EN/UL/CSA standards.

Note3. Use 1.25 mm² (AWG16) to comply with IEC/EN/UL/CSA standards.

11. OPTIONS AND PERIPHERAL EQUIPMENT

(2) Wires for cables

When fabricating a cable, use the wire models given in the following table or equivalent.

Table 11.3 Wires for option cables

Type	Model	Length [m]	Core size [mm ²]	Number of Cores	Characteristics of one core			(Note 2) Finishing OD [mm]	Wire model
					Structure [Wires/mm]	Conductor resistance [Ω /km]	Insulation coating OD d [mm] (Note 1)		
Encoder Cable	LE-CSE-S□A	2 to 10	AWG22	6 (3 pairs)	7/0.26	53 or less	1.2	7.1±0.3	(Note 3) VSVP 7/0.26 (AWG#22 or equivalent)-3P Ban-gi-shi-16823
	LE-CSE-S□B								
	LE-CSE-R□A	2 to 10	AWG22	6 (3 pairs)	70/0.08	56 or less	1.2	7.1±0.3	(Note 3) ETFE · SVP 70/0.08 (AWG#22 or equivalent)-3P Ban-gi-shi-16824
	LE-CSE-R□B								
Motor cable	LE-CSM-S□A	2 to 10	AWG18	4	34/0.18	21.8 or less	1.71	6.2±0.3	HRZFV-A(CL3) AWG18 4 cores
	LE-CSM-S□B	2 to 10							
	LE-CSM-R□A	2 to 10	(Note 5) AWG19	4	150/0.08	29.1 or less	1.63	5.7±0.5	(Note 4) RMFES-A(CL3X) AWG19 4 cores
	LE-CSM-R□B	2 to 10							
Lock cable	LE-CSB-S□A	2 to 10	AWG20	2	21/0.18	34.6 or less	1.35	4.7±0.1	HRZFV-A(CL3) AWG20 2 cores
	LE-CSB-S□B	2 to 10							
	LE-CSB-R□A	2 to 10	Note 5) AWG20	2	110/0.08	39.0 or less	1.37	4.5±0.3	(Note 4) RMFES-A(CL3X) AWG20 2 cores
	LE-CSB-R□B	2 to 10							

Note 1. d is as shown below.

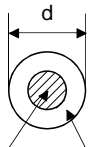

Conductor Insulation sheath

2. Standard OD. Max. OD is about 10% greater.
3. Purchased from Toa Electric Industry
4. Purchased from taisei
5. These wire sizes assume that the UL-compliant wires are used at the wiring length of 10m.

11. OPTIONS AND PERIPHERAL EQUIPMENT

11.6 Molded-case circuit breakers, fuses, magnetic contactors (recommended)

(1) For main circuit power supply

To prevent the driver from smoke and a fire, select a molded-case circuit breaker which shuts off with high speed.

Always use one molded-case circuit breaker and one magnetic contactor with one driver.

When using a fuse instead of the molded-case circuit breaker, use the one having the specifications given in this section.

Driver	Molded-case circuit breaker (Note 1, 3)			Fuse			Magnetic contactor (Note 2)
	Frame, rated current		Voltage AC [V]	Class	Current [A]	Voltage AC [V]	
	Power factor Improving reactor is not used	Power factor Improving reactor is used					
LECSND2-T5	30 A frame 5 A		240	T	10	300	S-N10 (Mitsubishi Electric Corporation)
LECSND2-T7					15		
LECSND2-T8	30A frame 10A	30A frame 5A			20		
LECSND2-T9	30A frame 15A	30A frame 10A					

Note 1. When having the driver comply with the IEN/EN/UL/CSA standard, refer to app.4.

2. Use a magnetic contactor with an operation delay time (interval between current being applied to the coil until closure of contacts) of 80 ms or less.

3. Use a molded-case circuit breaker with equal or higher operating characteristics.

(2) For control circuit power supply

When the wiring for the control circuit power supply (L11, L21) is thinner than that for the main circuit power supply (L1, L2, L3), install an overcurrent protection device (molded-case circuit breaker or fuse) to protect the branch circuit.

Driver	Molded-case circuit breaker		Fuse (Class T)		Fuse (Class K5)	
	Frame, rated current	Voltage AC [V]	Current [A]	Voltage AC [V]	Current [A]	Voltage AC [V]
LECSND□-T5	30 A frame 5 A	240	1	300	1	250
LECSND□-T7						
LECSND□-T8						
LECSND2-T9						

11.7 Relay (recommended)

The following relays should be used with the interfaces

Interface	Selection example
Digital input (interface DI-1) Relay used for digital input command signals	To prevent defective contacts, use a relay for small signal (twin contacts). (Ex.) Omron : type G2A, MY
Digital output (interface DO-1) Relay used for digital output signals	Small relay with 12 V DC or 24 V DC of rated current 40 mA or less (Ex.) Omron : type MY

11. OPTIONS AND PERIPHERAL EQUIPMENT

11.8 Noise reduction techniques

Noises are classified into external noises which enter the driver to cause it to malfunction and those radiated by the driver to cause peripheral equipment to malfunction. Since the driver is an electronic device which handles small signals, the following general noise reduction techniques are required. Also, the driver can be a source of noise as its outputs are chopped by high carrier frequencies. If peripheral equipment malfunction due to noises produced by the driver, noise suppression measures must be taken. The measures will vary slightly with the routes of noise transmission.

(1) Noise reduction techniques

(a) General reduction techniques

- Avoid bundling power lines (input/output) and signal cables together or running them in parallel to each other. Separate the power lines from the signal cables.
- Use a shielded twisted pair cable for connection with the encoder and for control signal transmission, and connect the external conductor of the cable to the SD terminal.
- Ground the driver, servo motor, etc. together at one point. (Refer to section 3.11.)

(b) Reduction techniques for external noises that cause the driver to malfunction

If there are noise sources (such as a magnetic contactor, a lock, and many relays which make a large amount of noise) near the driver and the driver may malfunction, the following countermeasures are required.

- Provide surge absorbers on the noise sources to suppress noises.
- Attach data line filters to the signal cables.
- Ground the shields of the encoder connecting cable and the control signal cables with cable clamp fittings.
- Although a surge absorber is built into the driver, to protect the driver and other equipment against large exogenous noise and lightning surge, attaching a varistor to the power input section of the equipment is recommended.

(c) Techniques for noises radiated by the driver that cause peripheral equipment to malfunction

Noises produced by the driver are classified into those radiated from the cables connected to the driver and its main circuits (input and output circuits), those induced electromagnetically or statically by the signal cables of the peripheral equipment located near the main circuit cables, and those transmitted through the power supply cables.

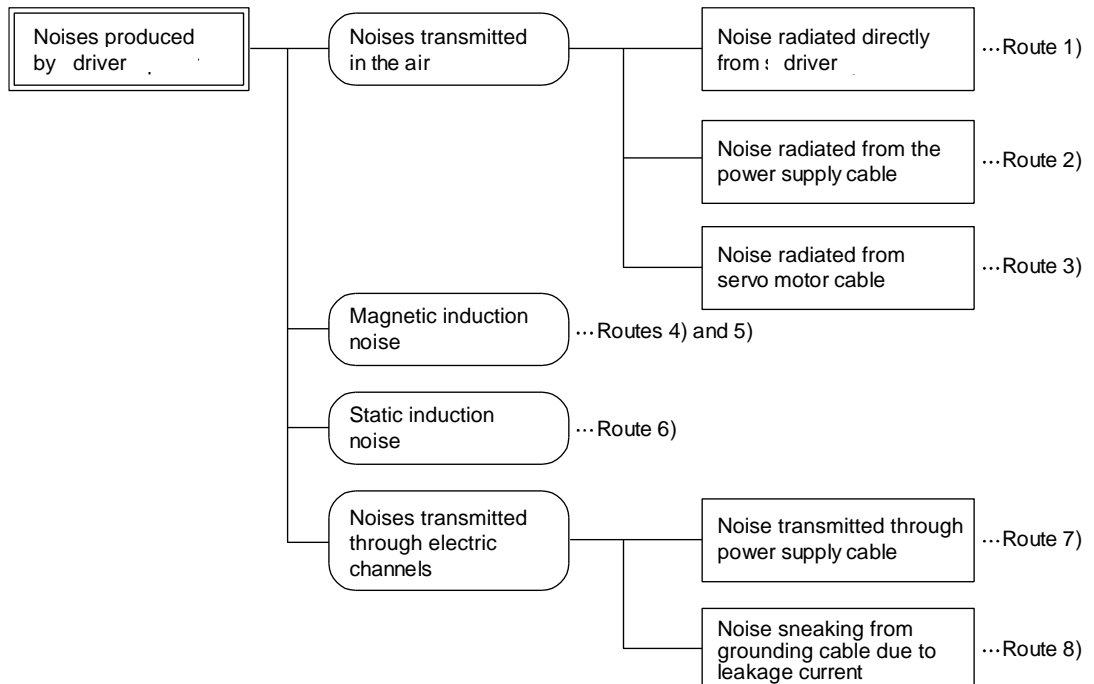

11. OPTIONS AND PERIPHERAL EQUIPMENT

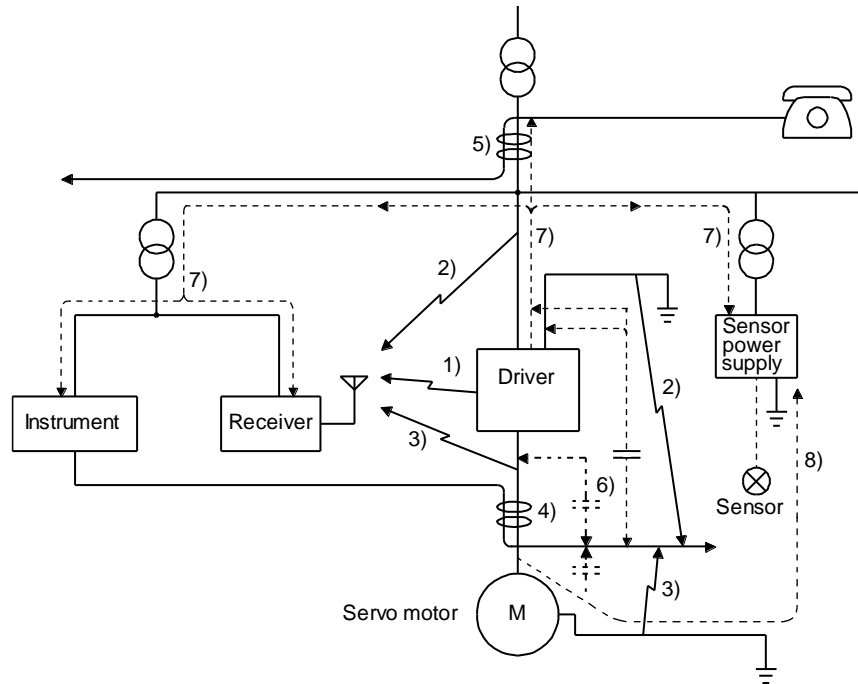

Noise transmission route	Suppression techniques
1) 2) 3)	<p>When measuring instruments, receivers, sensors, etc. which handle weak signals and may malfunction due to noise and/or their signal cables are contained in a cabinet together with the driver or run near the driver, such devices may malfunction due to noises transmitted through the air. The following techniques are required.</p> <ol style="list-style-type: none"> 1. Provide maximum clearance between easily affected devices and the driver. 2. Provide maximum clearance between easily affected signal cables and the I/O cables of the driver. 3. Avoid wiring the power lines (input/output lines of the driver) and signal lines side by side or bundling them together. 4. Insert a line noise filter to the I/O cables or a radio noise filter on the input line. 5. Use shielded wires for the signal and power lines, or put the lines in separate metal conduits.
4) 5) 6)	<p>When the power lines and the signal lines are laid side by side or bundled together, magnetic induction noise and static induction noise will be transmitted through the signal cables and malfunction may occur. The following techniques are required.</p> <ol style="list-style-type: none"> 1. Provide maximum clearance between easily affected devices and the driver. 2. Provide maximum clearance between easily affected signal cables and the I/O cables of the driver. 3. Avoid wiring the power lines (input/output lines of the driver) and signal lines side by side or bundling them together. 4. Use shielded wires for the signal and power lines, or put the lines in separate metal conduits.
7)	<p>When the power supply of peripheral equipment is connected to the power supply of the driver system, noises produced by the driver may be transmitted back through the power supply cable and the devices may malfunction. The following techniques are required.</p> <ol style="list-style-type: none"> 1. Install the radio noise filter (FR-BIF of Mitsubishi Electric Corporation) on the power lines (Input lines) of the driver. 2. Install the line noise filter (FR-BSF01/FR-BLF of Mitsubishi Electric Corporation) on the power lines of the driver.
8)	<p>When the cables of peripheral equipment are connected to the driver to make a closed loop circuit, leakage current may flow to malfunction the peripheral equipment. If so, malfunction may be prevented by disconnecting the grounding cable of the peripheral device.</p>

11. OPTIONS AND PERIPHERAL EQUIPMENT

(d) Noise reduction techniques for the network cable

POINT
● Take measures against noise for both ends of the network cable.

When using it in an environment with excessive noise, directly connect the shield of the network cable to the ground plate with cable clamp fittings at a place 200 mm to 300 mm or less from the driver.

When connecting the network cable from outside the cabinet, connect it to the ground plate at a place 5 mm to 10 mm away from the cabinet entrance.

To reinforce measures against noise, it is recommended to install a data line filter (TDK ZCAT1730-0730) to the network cable. Install the data line filter to a place 80 mm or less from the driver.

1) For inside the cabinet

a) When using cable clamp fittings

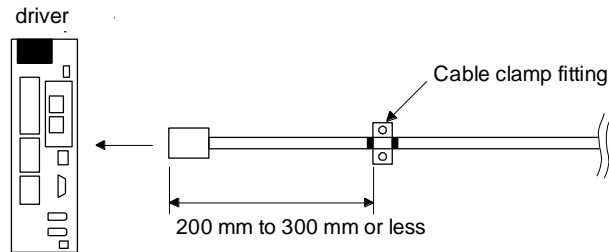

b) When using a data line filter

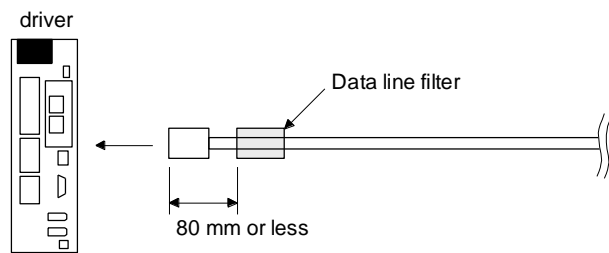

2) For outside the cabinet

a) When using cable clamp fittings

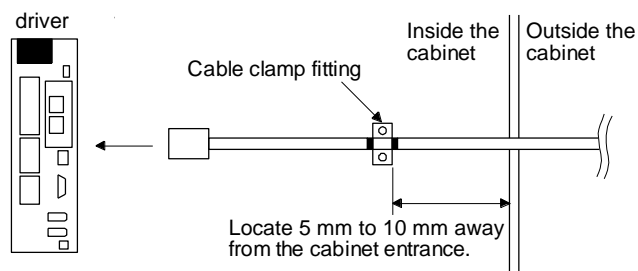

b) When using a data line filter

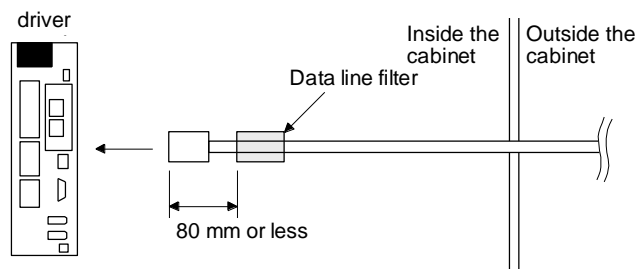

11. OPTIONS AND PERIPHERAL EQUIPMENT

(2) Noise reduction techniques

(a) Data line filter (recommended)

Noise can be prevented by installing a data line filter onto the encoder cable, etc.

For example, ZCAT3035-1330 by TDK, ESD-SR-250 by NEC TOKIN, and GRFC-13 by Kitagawa Industries are available as data line filters.

As a reference example, the impedance specifications of the ZCAT3035-1330 (TDK) are indicated below. These impedances are reference values and not guaranteed values.

Impedance [Ω]	
10 MHz to 100 MHz	100 MHz to 500 MHz
80	150

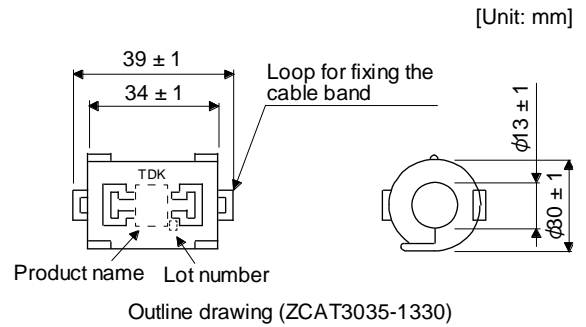

(b) Surge killer (recommended)

Use of a surge killer is recommended for AC relay, magnetic contactor or the like near the driver. Use the following surge killer or equivalent.

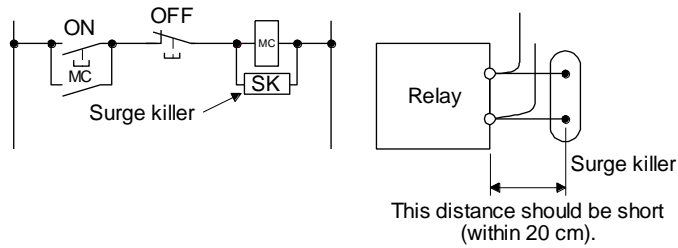

(Ex.) CR-50500 Okaya Electric Industries

Rated voltage AC [V]	C [$\mu\text{F} \pm 20\%$]	R [$\Omega \pm 30\%$]	Test voltage
250	0.5	50 (1/2W)	Between terminals: 625 V AC, 50 Hz/60 Hz 60 s Between terminal and case: 2000 V AC 50/60 Hz 60 s

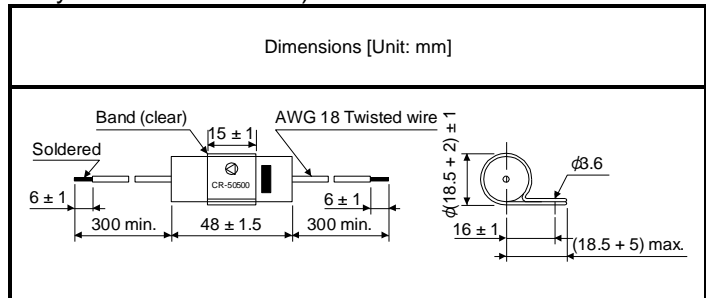

Note that a diode should be installed to a DC relay or the like.

Maximum voltage: Not less than four times the drive voltage of the relay or the like.

Maximum current: Not less than twice the drive current of the relay or the like.

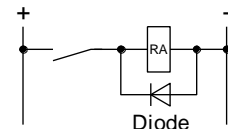

11. OPTIONS AND PERIPHERAL EQUIPMENT

(c) Cable clamp fitting (AERSBAN -□SET (Mitsubishi Electric Corporation))

Generally, the grounding of the shielded wire may only be connected to the connector's SD terminal. However, the effect can be increased by directly connecting the cable to an grounding plate as shown below.

Install the grounding plate near the driver for the encoder cable. Peel part of the cable sheath to expose the external conductor, and press that part against the grounding plate with the cable clamp.

If the cable is thin, clamp several cables in a bunch.

The cable clamp comes as a set with the grounding plate. [Unit: mm]

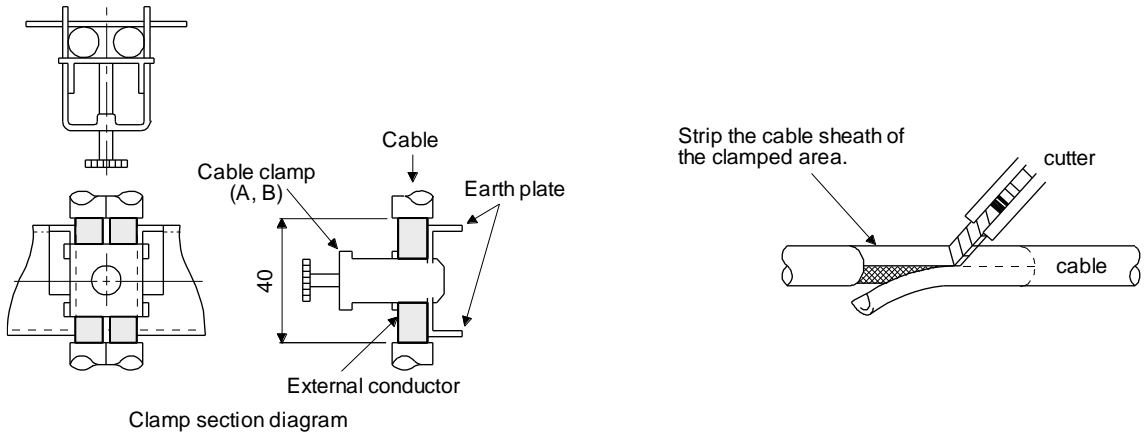

▪ Dimensions

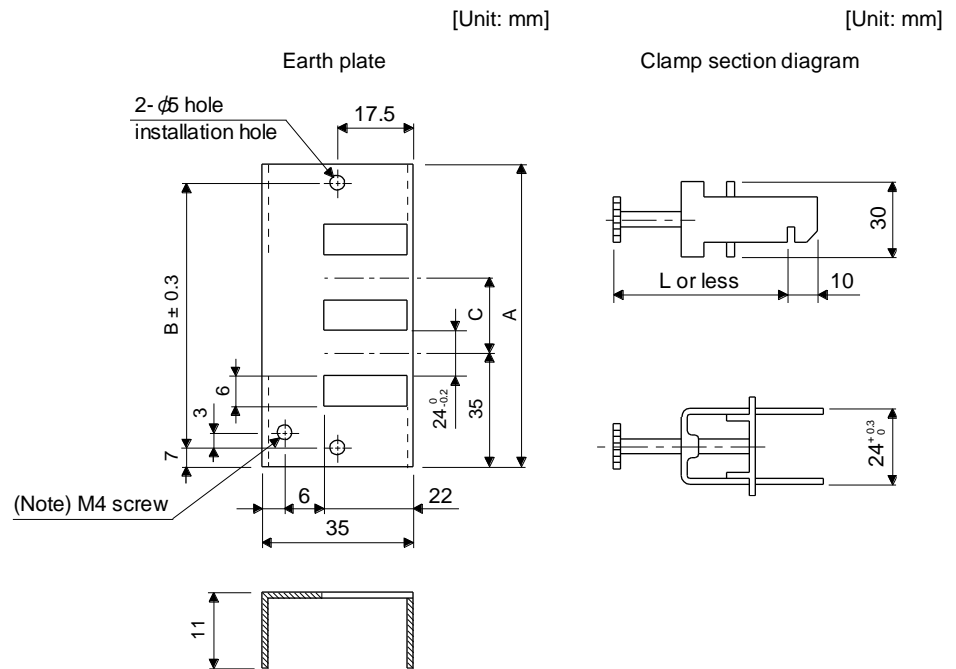

Note. Screw hole for grounding. Connect it to the grounding plate of the cabinet.

Model	A	B	C	Accessory fittings
AERSBAN-DSET	100	86	30	Clamp A: 2pcs.
AERSBAN-ESET	70	56		Clamp B: 1pc.

Clamp fitting	L
A	70
B	45

11. OPTIONS AND PERIPHERAL EQUIPMENT

(d) Line noise filter (FR-BSF01/FR-BLF of Mitsubishi Electric Corporation)

This filter is effective in suppressing noises radiated from the power supply side and output side of the driver and also in suppressing high-frequency leakage current (0-phase current). It especially affects the noises between 0.5 MHz and 5 MHz band.

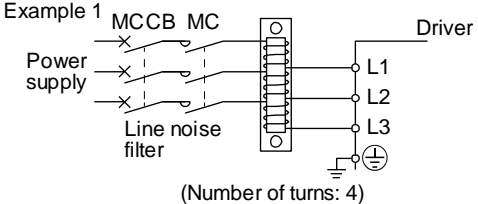
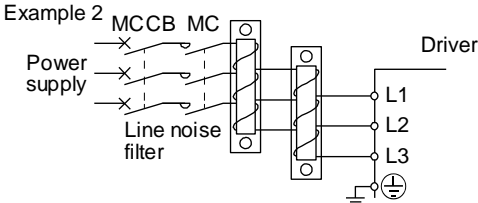
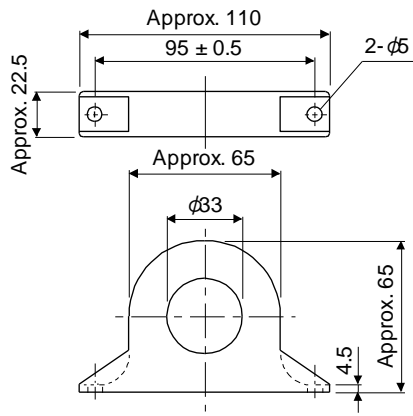
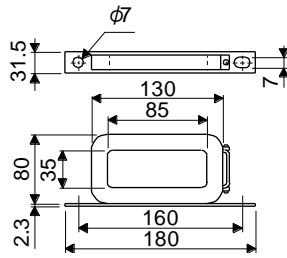
Connection diagram	Dimensions [Unit: mm]
<p>Use the line noise filters for lines of the main power supply (L1, L2, and L3) and of the servo motor power (U, V, and W). Pass each of the wires through the line noise filter an equal number of times in the same direction. For the main power supply, the effect of the filter rises as the number of passes increases, but generally four passes would be appropriate. For the servo motor power lines, passes must be four times or less. Do not pass the grounding wire through the filter, or the effect of the filter will drop. Wind the wires by passing through the filter to satisfy the required number of passes as shown in Example 1. If the wires are too thick to wind, use two or more filters to have the required number of passes as shown in Example 2.</p> <p>Place the line noise filters as close to the driver as possible for their best performance.</p> <div style="display: flex; flex-direction: column; align-items: center;"> <div style="display: flex; align-items: center; margin-bottom: 20px;"> <div style="text-align: center;"> <p>Example 1</p>  <p>(Number of turns: 4)</p> </div> <div style="margin-left: 20px;"> <p>Driver</p> <p>L1</p> <p>L2</p> <p>L3</p> <p>⊕</p> </div> </div> <div style="display: flex; align-items: center;"> <div style="text-align: center;"> <p>Example 2</p>  <p>Two filters are used (Total number of turns: 4)</p> </div> <div style="margin-left: 20px;"> <p>Driver</p> <p>L1</p> <p>L2</p> <p>L3</p> <p>⊕</p> </div> </div> </div>	<p>FR-BSF01 (for wire size 3.5 mm² (AWG 12) or less)</p>  <p>FR-BLF (for wire size 5.5 mm² (AWG 10) or more)</p> 

11. OPTIONS AND PERIPHERAL EQUIPMENT

(e) Radio noise filter (FR-BIF of Mitsubishi Electric Corporation)

This filter is effective in suppressing noises radiated from the power supply side of the driver especially in 10 MHz and lower radio frequency bands. The FR-BIF is designed for the input only.

200 V class: FR-BIF

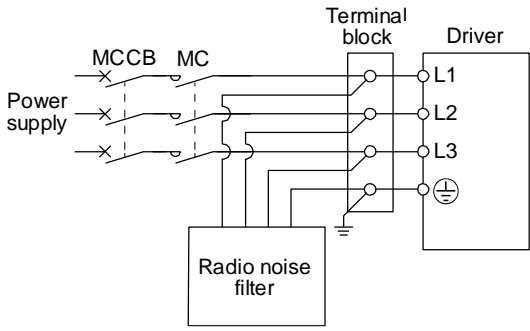
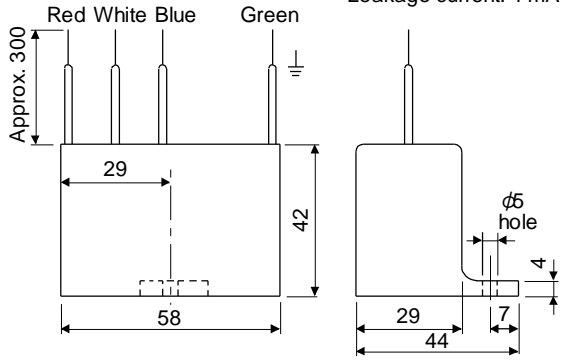
Connection diagram	Dimensions [Unit: mm]
<p>Make the connection cables as short as possible. Grounding is always required.</p> <p>When using the FR-BIF with a single-phase power supply, always insulate the lead wires that are not used for wiring.</p> <ul style="list-style-type: none"> • LECSB2-T□ 	<p>Leakage current: 4 mA</p> 

11. OPTIONS AND PERIPHERAL EQUIPMENT

(f) Varistor for input power supply (recommended)

Varistors are effective to prevent exogenous noise and lightning surge from entering the driver. When using a varistor, connect it between each phase of the input power supply of the equipment. For varistors, the TND20V-431K and TND20V-471K, manufactured by NIPPON CHEMI-CON, are recommended. For detailed specification and usage of the varistors, refer to the manufacturer catalog.

Power supply voltage	Varistor	Maximum rating					Maximum limit voltage		Static capacity (reference value)	Varistor voltage rating (range) V1 mA
		Permissible circuit voltage		Surge current immunity	Energy immunity	Rated pulse power	[A]	[V]		
		AC [Vrms]	DC [V]	8/20 μ s [A]	2 ms [J]	[W]			[pF]	[V]
200 V class	TND20V-431K	275	350	10000/1 times	195	1.0	100	710	1300	430 (387 to 473)
	TND20V-471K	300	385	7000/2 times	215			775	1200	470 (423 to 517)

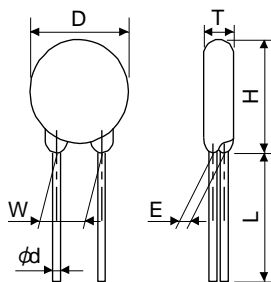

[Unit: mm]

Model	D Max.	H Max.	T Max.	E ± 1.0	(Note) L min.	ϕd ± 0.05	W ± 1.0
TND20V-431K	21.5	24.5	6.4	3.3	20	0.8	10.0
TND20V-471K			6.6	3.5			

Note. For special purpose items for lead length (L), contact the manufacturer.

11. OPTIONS AND PERIPHERAL EQUIPMENT

11.9 Earth-leakage current breaker

(1) Selection method

High-frequency chopper currents controlled by pulse width modulation flow in the AC servo circuits. Leakage currents containing harmonic contents are larger than those of the motor which is run with a commercial power supply.

Select an earth-leakage current breaker according to the following formula, and ground the driver, servo motor, etc. securely.

To minimize leakage currents, make the input and output cables as short as possible, and make the grounding cable longer than 30 cm.

$$\text{Rated sensitivity current} \geq 10 \cdot \{I_{g1} + I_{gn} + I_{ga} + K \cdot (I_{g2} + I_{gm})\} \text{ [mA]} \dots\dots\dots (11.1)$$

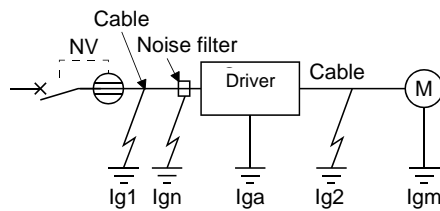

Earth-leakage current breaker		K
Type	Mitsubishi Electric Corporation products	
Models provided with harmonic and surge reduction techniques	NV-SP NV-SW NV-CP NV-CW NV-HW	1
General models	BV-C1 NFB NV-L	3

I_{g1}: Leakage current on the electric channel from the earth-leakage current breaker to the input terminals of the driver (Found from Fig. 11.5.)

I_{g2}: Leakage current on the electric channel from the output terminals of the driver to the servo motor (Found from Fig. 11.5.)

I_{gn}: Leakage current when a filter is connected to the input side (4.4 mA per one FR-BIF)

I_{ga}: Leakage current of the driver (Found from table 11.3.)

I_{gm}: Leakage current of the servo motor (Found from table 11.2.)

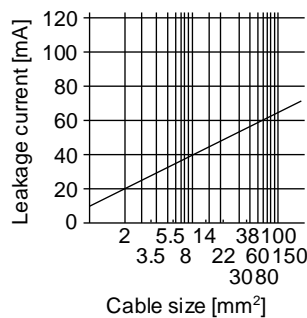

Fig. 11.7 Example of leakage current per km (I_{g1}, I_{g2}) for CV cable run in metal conduit

11. OPTIONS AND PERIPHERAL EQUIPMENT

Table 11.2 Servo motor leakage current example (I_{gm})

Servo motor power [W]	Leakage current [mA]
50 to 750	0.1

Table 11.3 Driver leakage current example (I_{ga})

Driver capacity [W]	Leakage current [mA]
100 to 400	0.1
750	0.15

Table 11.4 Earth-leakage current breaker selection example

Driver	Rated sensitivity current of earth-leakage current breaker [mA]
LECSB2-T□	15

(2) Selection example

Indicated below is an example of selecting an earth-leakage current breaker under the following conditions.

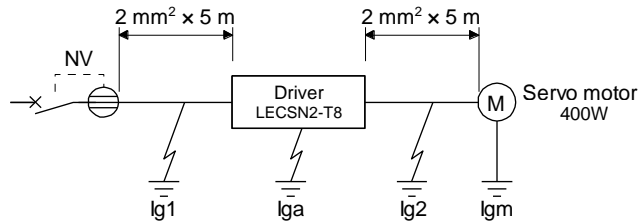

Use an earth-leakage current breaker designed for suppressing harmonics/surges. Find the terms of equation (11.1) from the diagram.

$$I_{g1} = 20 \cdot \frac{5}{1000} = 0.1 \text{ [mA]}$$

$$I_{g2} = 20 \cdot \frac{5}{1000} = 0.1 \text{ [mA]}$$

$$I_{gn} = 0 \text{ (not used)}$$

$$I_{ga} = 0.1 \text{ [mA]}$$

$$I_{gm} = 0.1 \text{ [mA]}$$

Insert these values in equation (11.1).

$$I_g \geq 10 \cdot \{0.1 + 0 + 0.1 + 1 \cdot (0.1 + 0.1)\} \geq 4 \text{ [mA]}$$

According to the result of calculation, use an earth-leakage current breaker having the rated sensitivity current (I_g) of 4.0 mA or more.

An earth-leakage current breaker having I_g of 15 mA is used with the NV-SP/SW/CP/CW/HW series.

11. OPTIONS AND PERIPHERAL EQUIPMENT

11.10 EMC filter (recommended)

It is recommended that one of the following filters be used to comply with EN EMC directive. Some EMC filters have large in leakage current.

(1) Combination with the driver

Driver	Recommended filter (Soshin Electric)			Mass [kg]	
	Model	Rated current [A]	Rated voltage [VAC]		Leakage current [mA]
LECSND□-T□	(Note) HF3010A-UN	10	250	5	3.5

Note. A surge protector is separately required to use any of these EMC filters.

(2) Connection example

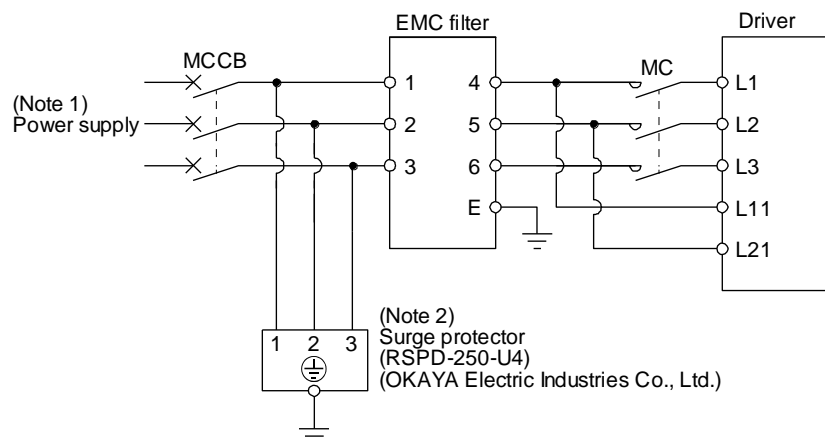

- Note 1. For 1-phase 200 V AC to 240 V AC, connect the power supply to L1 and L3. Leave L2 open.
- Note 2. The example is when a surge protector is connected.

11. OPTIONS AND PERIPHERAL EQUIPMENT

- (3) Dimensions
 - (a) EMC filter
 - HF3010A-UN

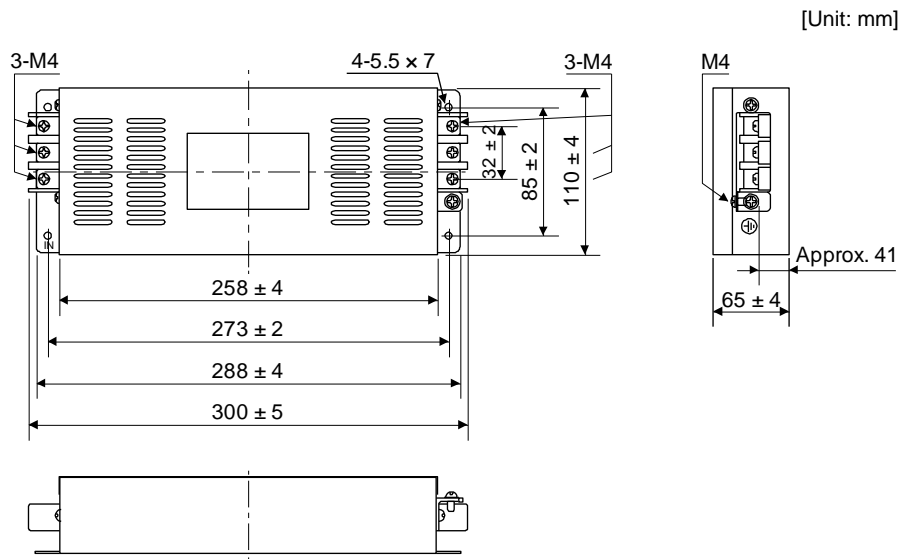

HF3030A-UN/HF-3040A-UN

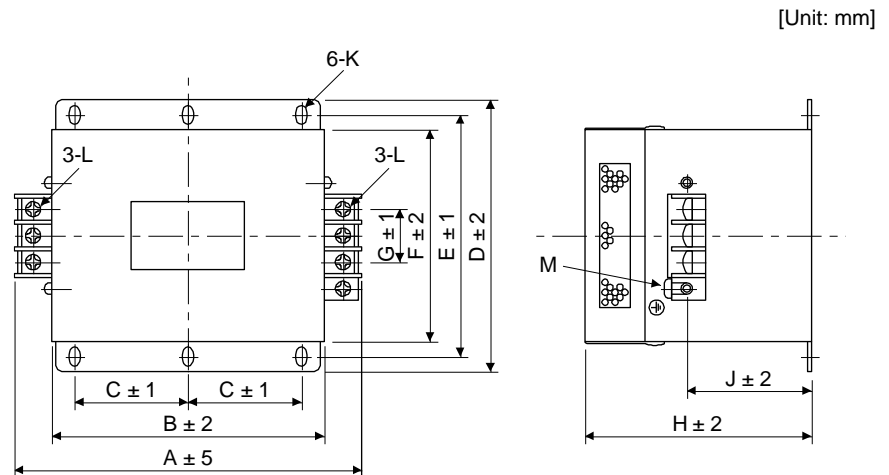

Model	Dimensions [mm]											
	A	B	C	D	E	F	G	H	J	K	L	M
HF3030A-UN	260	210	85	155	140	125	44	140	70	R3.25 length: 8	M5	M4
HF3040A-UN												

11. OPTIONS AND PERIPHERAL EQUIPMENT

HF3100A-UN

[Unit: mm]

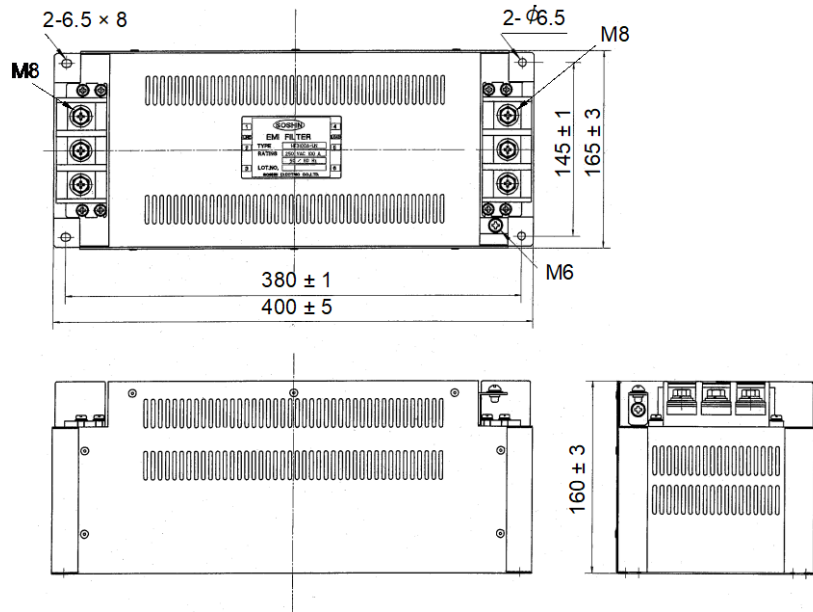

TF3005C-TX/TX3020C-TX/TF3030C-TX

[Unit: mm]

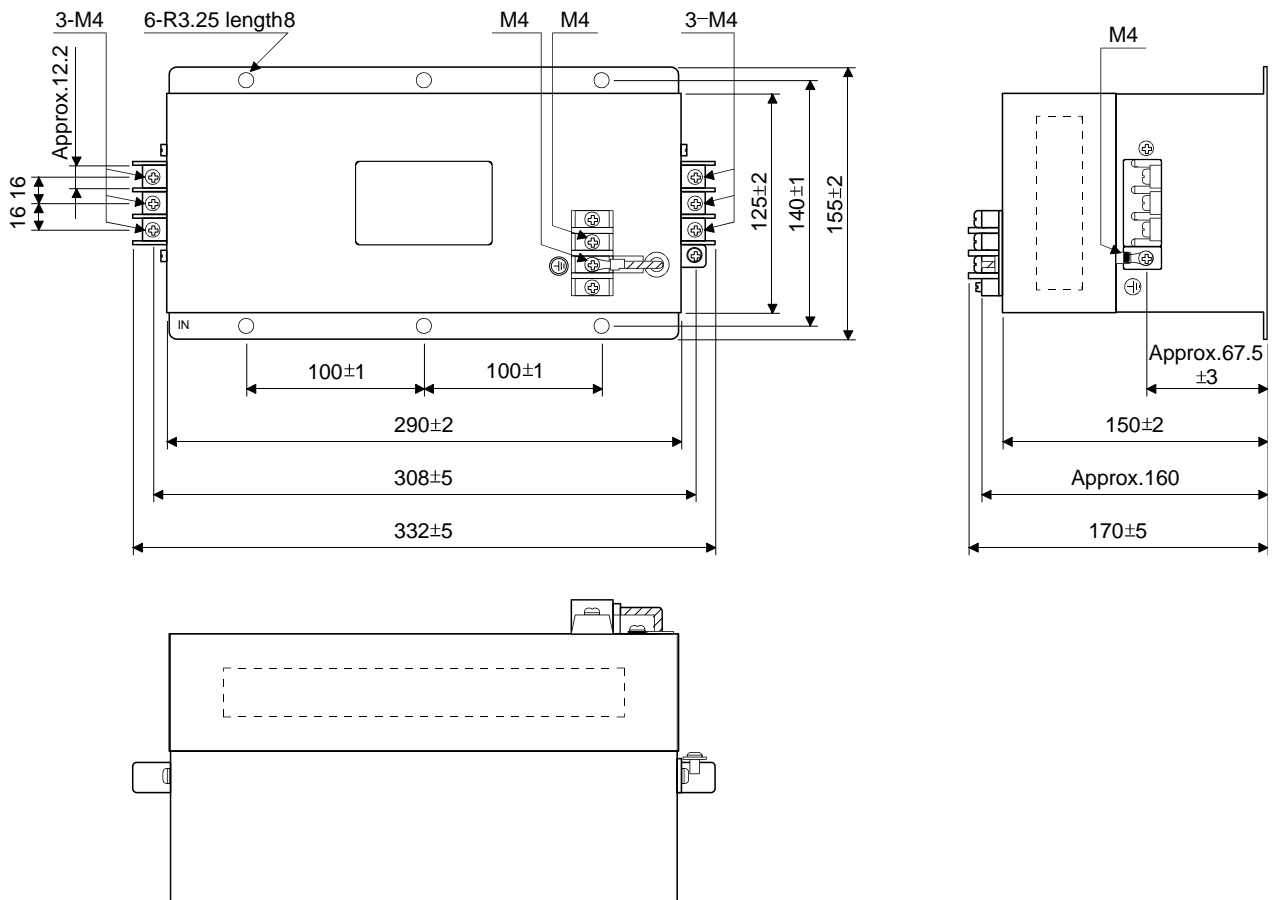

11. OPTIONS AND PERIPHERAL EQUIPMENT

(b) Surge protector

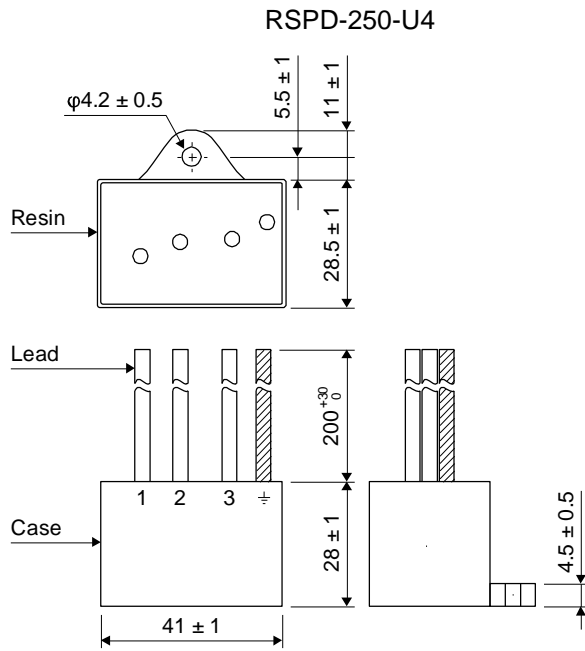

[Unit: mm]

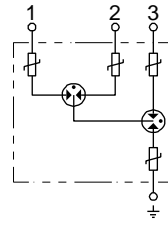

12. ABSOLUTE POSITION DETECTION SYSTEM

12. ABSOLUTE POSITION DETECTION SYSTEM	2
12.1 Summary	2
12.1.1 Features	2
12.1.2 Structure	2
12.1.3 Parameter setting	2
12.1.4 Confirmation of absolute position detection data	3
12.2 Battery	4
12.3 Battery replacement procedure	5
12.4 Constructing an absolute position detection system with the upper side that does not use the home position return mode of the driver	7
12.4.1 Overview	7
12.4.2 Start-up procedure	7
12.4.3 Usage precautions and restrictions	8

12. ABSOLUTE POSITION DETECTION SYSTEM

12. ABSOLUTE POSITION DETECTION SYSTEM

! CAUTION

- If [AL. 25 Absolute position erased] or [AL. E3 Absolute position counter warning] has occurred, always perform home position setting again. Otherwise, it may cause an unexpected operation.
- If [AL. 25], [AL. 92], or [AL. 9F] occurs due to such as short circuit of the battery, the battery can become hot. Use the battery with care to prevent getting burnt.

POINT

- Refer to section 12.3 for the replacement procedure of the battery.
- When absolute position data is erased from the encoder, always execute home position setting before operation. The absolute position data of the encoder will be erased in the followings. Additionally, when the battery is used out of specification, the absolute position data can be erased.
 - The encoder cable was disconnected.
 - The battery was replaced when the control circuit power supply was off.

12.1 Summary

12.1.1 Features

For normal operation, as shown below, the encoder consists of a detector designed to detect a position within one revolution and a cumulative revolution counter designed to detect the number of revolutions. The absolute position detection system always detects the absolute position of the machine and keeps it battery-backed, independently of whether the servo system PC or PLC...etc power is on or off. Therefore, once home position return is made at the time of machine installation, home position return is not needed when power is switched on thereafter. Even at a power failure or a malfunction, the system can be easily restored.

12.1.2 Structure

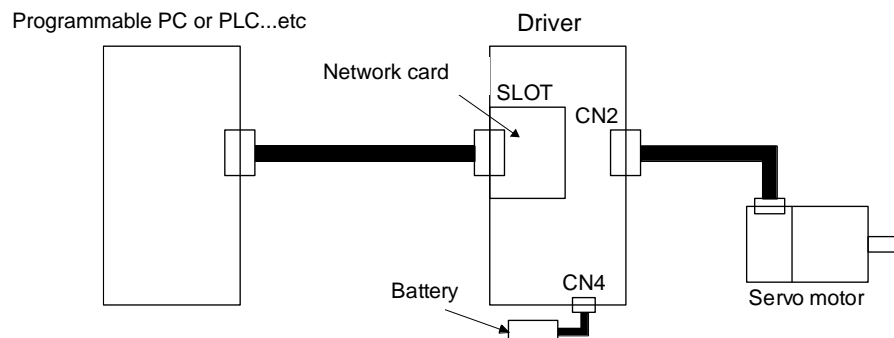

12.1.3 Parameter setting

Set " _ _ _ 1" in [Pr. PA03] to enable the absolute position detection system.

[Pr. PA03]

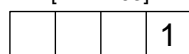

- Absolute position detection system selection
 0: Disabled (used in incremental system)
 1: Enabled (used in absolute position detection system)

12. ABSOLUTE POSITION DETECTION SYSTEM

12.1.4 Confirmation of absolute position detection data

You can check the absolute position data with SETUP SOFTWARE MR (Setup software MR Configurator2TM™). Choose "Monitor" and "ABS Data Display" to open the absolute position data display screen.

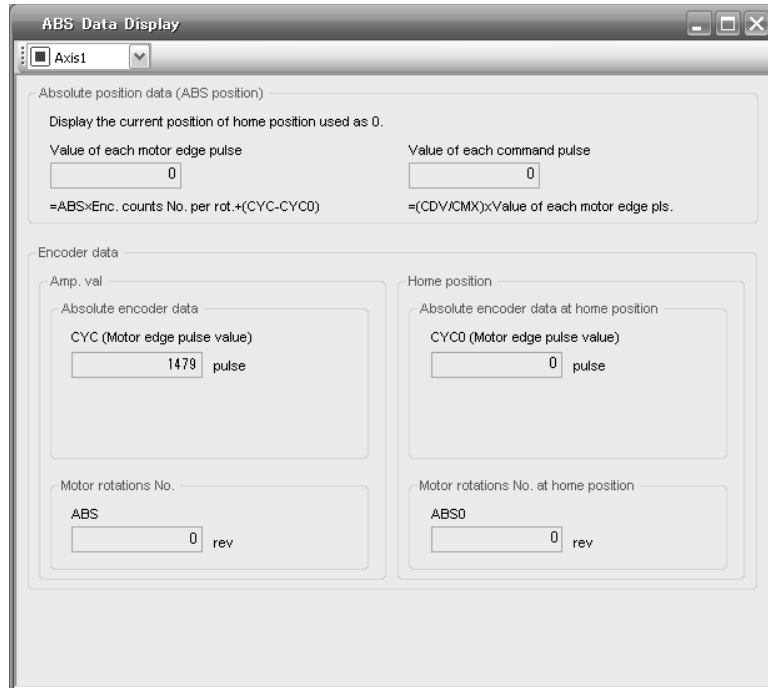

12. ABSOLUTE POSITION DETECTION SYSTEM

12.2 Battery

(1) Configuration diagram

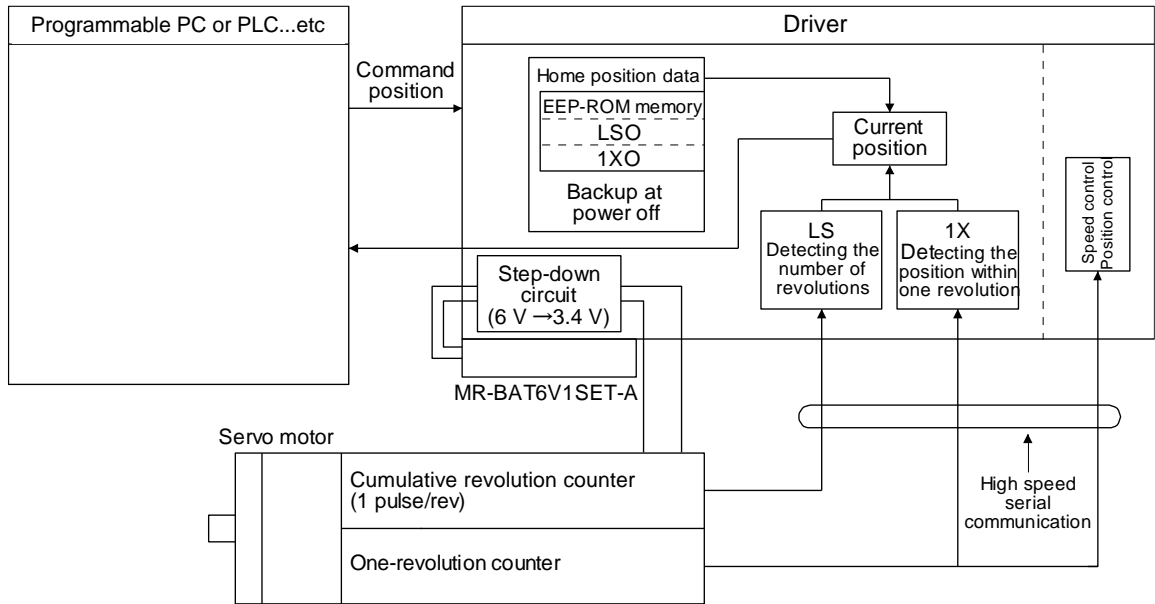

(2) Specifications

(a) Specification list

Item	Description
System	Electronic battery backup type
Maximum revolution range	Home position ± 32767 rev.
(Note 1)	6000
Maximum speed at power failure [r/min]	(only when acceleration time until 6000 r/min is 0.2 s or more)
(Note 2)	Approximately 20,000 hours (equipment power supply: off, ambient temperature: 20 °C)
Battery backup time	Approximately 29,000 hours (power-on time ratio: 25%, ambient temperature: 20 °C) (Note 3)

- Note 1. Maximum speed available when the shaft is rotated by external force at the time of power failure or the like. Also, if power is switched on at the servo motor speed of 3000 r/min or higher, position mismatch may occur due to external force or the like.
- Note 2. The data-holding time by the battery. Replace the batteries within three years since the operation start regardless of the power supply of the driver on/off. If the battery is used out of specification, [AL. 25 Absolute position erased] may occur.
- Note 3. The power-on time ratio 25% is equivalent to 8 hours power on for a weekday and off for a weekend.

12. ABSOLUTE POSITION DETECTION SYSTEM

12.3 Battery replacement procedure

WARNING

- Before installing a battery, turn off the main circuit power and wait for 15 minutes or longer until the charge lamp turns off. Then, check the voltage between P+ and N- with a voltage tester or others. Otherwise, an electric shock may occur. In addition, when confirming whether the charge lamp is off or not, always confirm it from the front of the driver.

CAUTION

- The internal circuits of the driver may be damaged by static electricity. Always take the following precautions.
 - Ground human body and work bench.
 - Do not touch the conductive areas, such as connector pins and electrical parts, directly by hand.

POINT

- Replacing battery with the control circuit power off will erase the absolute position data.
- Before replacing batteries, check that the new batteries are within battery life.
Please purchase replacement battery from Mitsubishi Electric Corporation.

Replace the battery while only control circuit power is on. Replacing battery with the control circuit power on triggers [AL. 9F.1 Low battery]. However, the absolute position data will not be erased.

12. ABSOLUTE POSITION DETECTION SYSTEM

(1) Installation procedure

POINT

- It is not possible to wire for the earth with the battery installed. Insert the battery after executing the earth wiring of the driver.

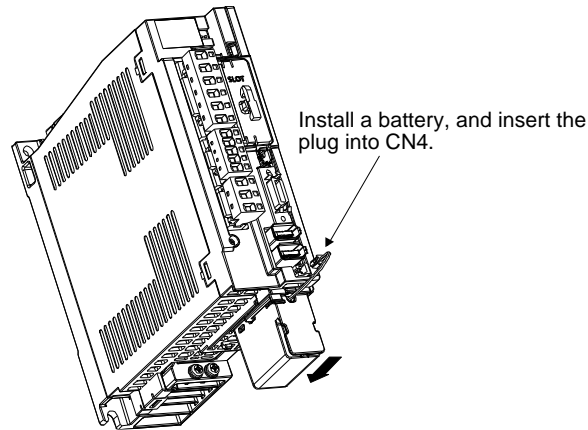

(2) Removal procedure



CAUTION

- Pulling out the connector of the battery without the lock release lever pressed may damage the CN4 connector of the driver or the connector of the battery.

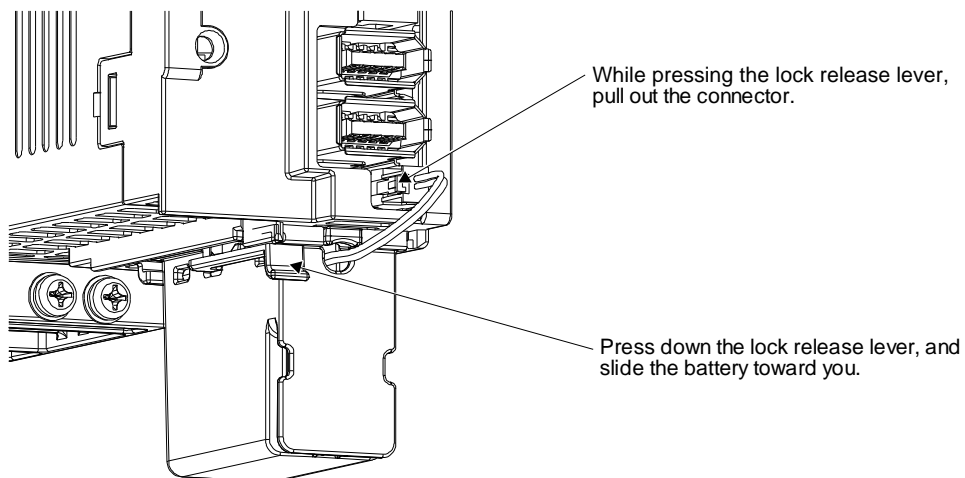

12. ABSOLUTE POSITION DETECTION SYSTEM

12.4 Constructing an absolute position detection system with the upper side that does not use the home position return mode of the driver

12.4.1 Overview

The upper side that does not use the driver's home position return mode does not set the home position return for the driver because the origin is controlled on the upper side.

The construction of an absolute position detection system with the upper side that does not use the driver's home position return mode is described below.

12.4.2 Start-up procedure

(1) Attaching the battery

For the battery installation, see Section 12.3

(2) Parameter setting

(a) Absolute position detection system

Set [Pr. PA03] to " _ _ _ 1" to enable the absolute position detection system.

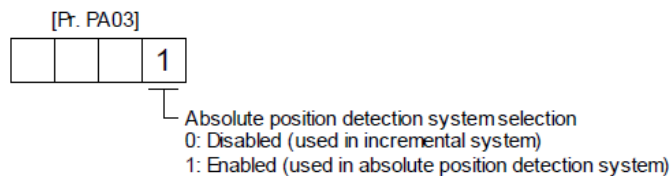

(b) Absolute position counter warning (AL-E3) Selection

[AL. E3.1] is generated when the amount of movement from the origin is 32768 rev or more.

Set [Pr. PC18] to " _ _ 0 _" to disable [AL. E3.1] .

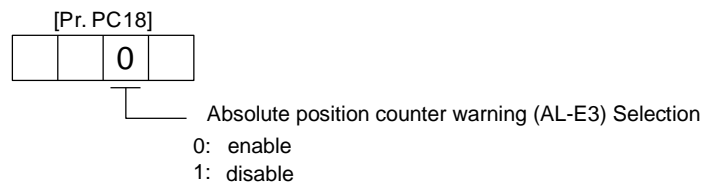

(c) Home position return incomplete (AL. 90.1) detection selection

[AL. 90.1] will occur when the servo is turned on if home position setting has not been performed for the driver .

Set [Pr. PC41] to " _ _ _ 1" to disable [AL. 90.1] .

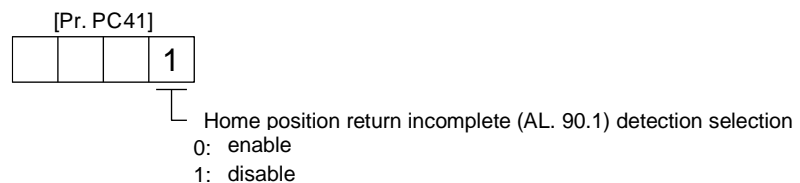

12. ABSOLUTE POSITION DETECTION SYSTEM

(3) Alarm deactivation of [AL. 25.1 Servo motor encoder absolute position erased]
[AL. 25.1 Servo motor encoder absolute position erased] occurs when the absolute position detection system is set for the first time .
Wait 5 seconds, then the power turn off → turn on.

(4) Home position return
Be sure to perform the home position return before performing a positioning operation.

12.4.3 Usage precautions and restrictions

Notes and restrictions are described below.

(1) The only control mode that home position return incomplete (AL. 90.1) detection selection can use is cyclic synchronous position mode (csp).

(2) The software limit function (607Dh: Software position limit) is not used because the home position is not set for the driver .

(3) [AL. 25 Absolute position erased] If this occurs , be sure to perform home position return on the upper side. It will cause unexpected movement.

(4) Do not rotate the servo motor beyond 2147483647 [pulse] when EtherCAT communication is not established .

The upper side cannot restore the current position correctly when communication is established .

13. USING STO FUNCTION

13. USING STO FUNCTION	2
13.1 Introduction	2
13.1.1 Summary	2
13.1.2 Terms related to safety	2
13.1.3 Cautions	2
13.1.4 Residual risks of the STO function	3
13.1.5 Specifications	4
13.1.6 Maintenance	5
13.2 STO I/O signal connector (CN8) and signal layouts	5
13.2.1 Signal layouts	5
13.2.2 Signal (device) explanations	6
13.2.3 How to pull out the STO cable	6
13.3 Connection example	7
13.3.1 Connection example for CN8 connector	7
13.3.2 External I/O signal connection example using an MR-J3-D05 safety logic unit of Mitsubishi Electric Corporation	8
13.3.3 External I/O signal connection example using an external safety relay unit	10
13.4 Detailed description of interfaces	11
13.4.1 Sink I/O interface	11
13.4.2 Source I/O interface	13

13. USING STO FUNCTION

13. USING STO FUNCTION

POINT

● In the torque control mode, the forced stop deceleration function is not available.

13.1 Introduction

This section provides the cautions of the STO function.

13.1.1 Summary

This driver complies with the following safety standards.

- ISO/EN ISO 13849-1 category 3 PL e
- IEC/EN 61508 SIL 3
- IEC/EN 61800-5-2
- IEC/EN 62061 SIL CL3

13.1.2 Terms related to safety

The STO function shuts down energy to servo motors, thus removing torque. This function electronically cuts off power supply in the driver.

The purpose of this safety function is as follows.

- (1) Uncontrolled stop according to stop category 0 of IEC/EN 60204-1
- (2) Preventing unexpected start-up

13.1.3 Cautions

The following basic safety notes must be read carefully and fully in order to prevent injury to persons or damage to property.

Only qualified personnel are authorized to install, start-up, repair, or service the machines in which these components are installed.

They must be familiar with all applicable local regulations and laws in which machines with these components are installed, particularly the standards mentioned in this manual.

The staff responsible for this work must be given express permission from the company to perform start-up, programming, configuration, and maintenance of the machine in accordance with the safety standards.



WARNING

● Improper installation of the safety related components or systems may cause improper operation in which safety is not assured, and may result in severe injuries or even death.

Protective Measures

- This driver satisfies the Safe Torque Off (STO) function described in IEC/EN 61800-5-2 by preventing the energy supply from the driver to the servo motor. If an external force acts upon the drive axis, additional safety measures, such as locks or counterbalances must be used.

13. USING STO FUNCTION

13.1.4 Residual risks of the STO function

Machine manufacturers are responsible for all risk evaluations and all associated residual risks. Below are residual risks associated with the STO function. SMC is not liable for any damages or injuries caused by these risks.

- (1) The STO function disables energy supply to the servo motor by electrical shut-off. The function does not mechanically disconnect electricity from the motor. Therefore, it cannot prevent exposure to electric shock. To prevent an electric shock, install a magnetic contactor or a molded-case circuit breaker to the main circuit power supply (L1, L2, and L3) of the driver.
- (2) The STO function disables energy supply to the servo motor by electrical shut-off. It does not guarantee the stop control or the deceleration control of the servo motor.
- (3) For proper installation, wiring, and adjustment, thoroughly read the manual of each individual safety related component.
- (4) In the safety circuit, use components that are confirmed safe or meet the required safety standards.
- (5) The STO function does not guarantee that the drive part of the servo motor will not rotate due to external or other forces.
- (6) Safety is not assured until safety-related components of the system are completely installed or adjusted.
- (7) When replacing this driver, confirm that the model name of drivers are exactly the same as those being replaced. Once installed, make sure to verify the performance of the safety functions before commissioning the system.
- (8) Perform all risk assessments to the machine or the whole system.
- (9) To prevent accumulation of malfunctions, perform malfunction checks at regular intervals based on the risk assessments of the machine or the system. Regardless of the system safety level, malfunction checks should be performed at least once per year.
- (10) If the upper and lower power module in the driver are shorted and damaged simultaneously, the servo motor may make a half revolution at a maximum.
- (11) The STO input signals (STO1 and STO2) must be supplied from one power source. Otherwise, the STO function may not function properly due to a sneak current, failing to bring the STO shut-off state.
- (12) For the STO I/O signals of the STO function, supply power by using a safety extra low voltage (SELV) power supply with the reinforced insulation.

13. USING STO FUNCTION

13.1.5 Specifications (1) Specifications

Item	Specifications
Safety function	STO (IEC/EN 61800-5-2)
Safety performance	ISO/EN ISO 13849-1 category 3 PL e, IEC/EN 61508 SIL 3, EN 62061 SIL CL3, EN 61800-5-2
Mean time to dangerous failure (MTTFd)	MTTFd ≥ 100 [years] (Note)
Diagnostic converge (DC)	DC = Medium, 97.6[%] (Note)
Average probability of dangerous failures per hour (PFH)	PFH = 6.4 × 10 ⁻⁹ [1/h]
Number of on/off times of STO	1,000,000 times
CE marking	LVD: EN 61800-5-1 EMC: EN 61800-3 MD: EN ISO 13849-1, EN 61800-5-2, EN 62061

- Note
1. This is the value required by safety standards.
 2. The safety level is determined by the setting value of [Pr. PF18 STO diagnosis error detection time] and whether or not STO input diagnosis by TOFB output is performed. For details, refer to the function column of [Pr. PF18] described in section 5.2.6.

(2) Function block diagram (STO function)

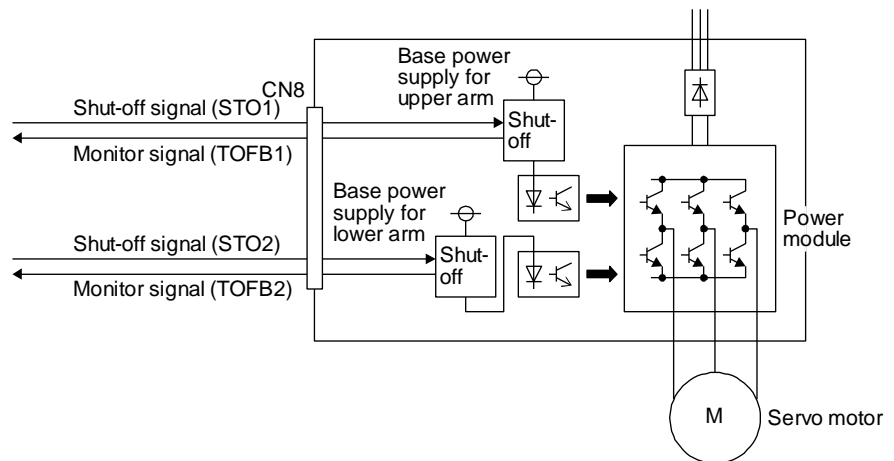

(3) Operation sequence (STO function)

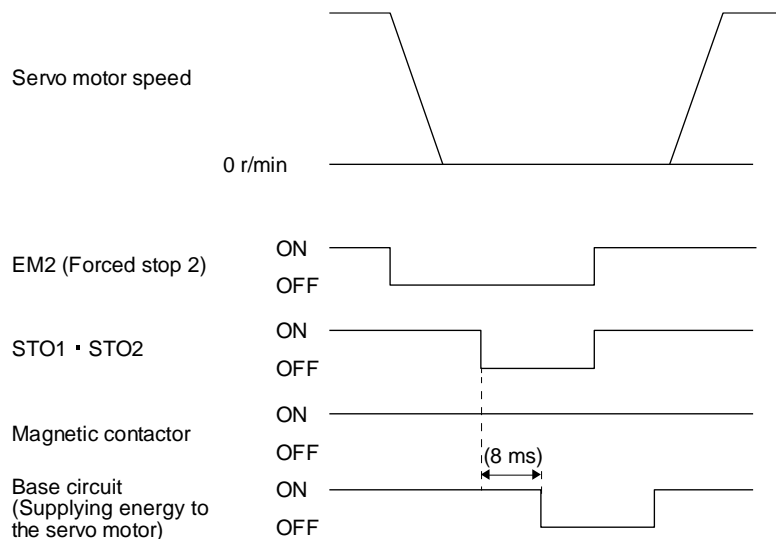

13. USING STO FUNCTION

13.1.6 Maintenance

This driver has alarms and warnings for maintenance that supports the drive safety function. (Refer to chapter 8.)

13.2 STO I/O signal connector (CN8) and signal layouts

13.2.1 Signal layouts

POINT
●The pin configurations of the connectors are as viewed from the cable connector wiring section.

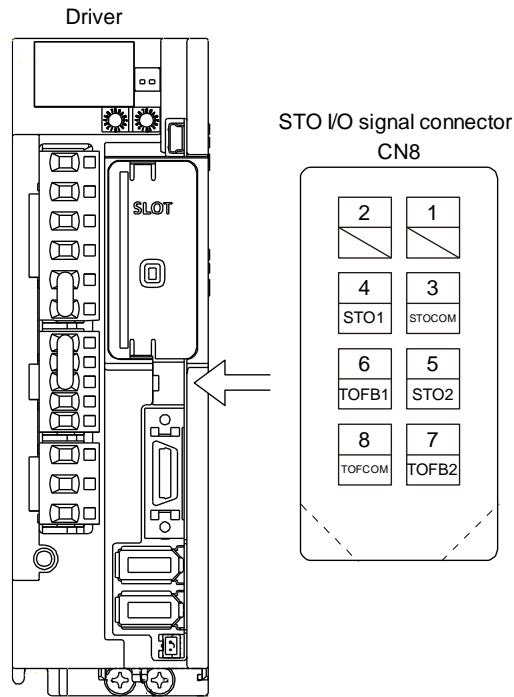

13. USING STO FUNCTION

13.2.2 Signal (device) explanations (1) I/O device

Signal name	Connector pin No.	Description	I/O division
STOCOM	CN8-3	Common terminal for input signal of STO1 and STO2	DI-1
STO1	CN8-4	Inputs STO state 1. STO state (base shut-off): Open between STO1 and STOCOM. STO release state (in driving): Close between STO1 and STOCOM. Be sure to turn off STO1 after the servo motor stops by the servo-off state or with forced stop deceleration by turning off EM2 (Forced stop 2).	DI-1
STO2	CN8-5	Inputs STO state 2. STO state (base shut-off): Open between STO2 and STOCOM. STO release state (in driving): Close between STO2 and STOCOM. Be sure to turn off STO2 after the servo motor stops by the servo-off state or with forced stop deceleration by turning off EM2 (Forced stop 2).	DI-1
TOFCOM	CN8-8	Common terminal for monitor output signal in STO state	DO-1
TOFB1	CN8-6	Monitor output signal in STO1 state STO state (base shut-off): Between TOFB1 and TOFCOM is closed. STO release state (in driving): Between TOFB1 and TOFCOM is opened.	DO-1
TOFB2	CN8-7	Monitor output signal in STO2 state STO state (base shut-off): Between TOFB2 and TOFCOM is closed. STO release state (in driving): Between TOFB2 and TOFCOM is opened.	DO-1

(2) Signals and STO state

The following table shows the TOFB and STO states when the power is on in normal state and STO1 and STO2 are on (closed) or off (opened).

Input signal		State		
STO1	STO2	Between TOFB1 and TOFCOM (Monitoring STO1 state)	Between TOFB2 and TOFCOM (Monitoring STO2 state)	Between TOFB1 and TOFB2 (Monitoring STO state of driver)
Off	Off	On: STO state (base circuit shut-off)	On: STO state (base circuit shut-off)	On: STO state (base circuit shut-off)
Off	On	On: STO state (base circuit shut-off)	Off: STO release state	Off: STO state (base circuit shut-off)
On	Off	Off: STO release state	On: STO state (base circuit shut-off)	Off: STO state (base circuit shut-off)
On	On	Off: STO release state	Off: STO release state	Off: STO release state

(3) Test pulse of STO input signal

Set the test pulse off time inputted from outside to 1 ms or less.

13.2.3 How to pull out the STO cable

The following shows how to pull out the STO cable from the CN8 connector of the driver.

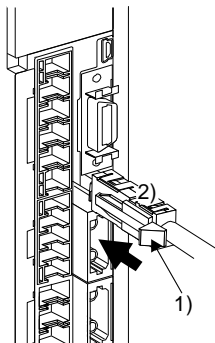

While pressing knob 1) of the STO cable plug in the direction of the arrow, pull out the plug 2).

13. USING STO FUNCTION

13.3 Connection example

POINT	
●	Turn off STO (STO1 and STO2) after the servo motor stops by the servo off state or with forced stop deceleration by turning off EM2 (Forced stop 2). Configure an external sequence that has the timings shown as below using an external device such as the MR-J3-D05 safety logic unit of Mitsubishi Electric Corporation.
●	If STO is turned off during operation, the servo motor is in dynamic lock stop (stop category 0), and [AL.63 STO timing error] will occur.

13.3.1 Connection example for CN8 connector

This driver is equipped with the connector (CN8) in accordance with the STO function. When this connector is used with a certified external safety relay, power to the motor can be safely removed and unexpected restart can be prevented. The safety relay used should meet the applicable safety standards and have forcibly guided or mirror contacts for the purpose of error detection.

In addition, the MR-J3-D05 safety logic unit of Mitsubishi Electric Corporation can be used instead of a safety relay for implementation of various safety standards. Refer to Appendix 5 for details.

The following diagram is for source interface. For sink interface, refer to section 13.4.1.

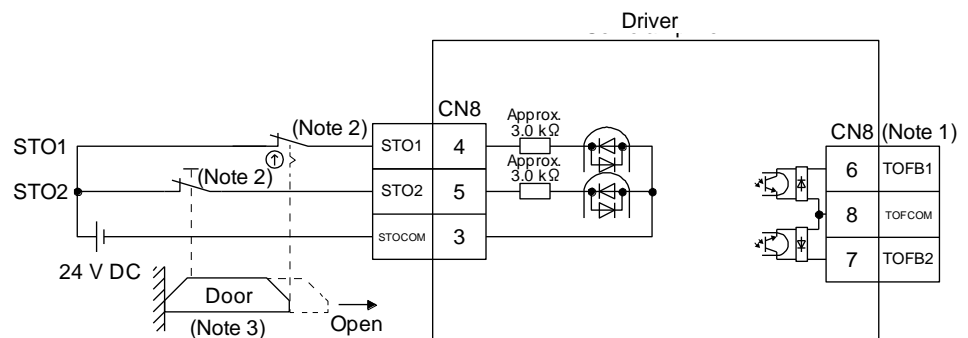

- Note 1. By using TOFB, whether the servo is in the STO state can be confirmed. For connection examples, refer to section 13.3.2 to 13.3.3. The safety level is determined by the setting value of [Pr. PF18 STO diagnosis error detection time] and whether or not STO input diagnosis by TOFB output is performed. For details, refer to the function column of [Pr. PF18] described in section 5.2.6.
- Note 2. When using the STO function, turn off STO1 and STO2 at the same time. Turn off STO1 and STO2 after the servo motor stops by the servo off state or with forced stop deceleration by turning off EM2 (Forced stop 2).
- Note 3. Configure the interlock circuit so that the door is open after the servo motor is stopped.

13. USING STO FUNCTION

13.3.2 External I/O signal connection example using an MR-J3-D05 safety logic unit of Mitsubishi Electric Corporation

POINT

● This connection is for the source interface. For the other I/O signals, refer to the connection examples in section 3.2.

(1) Connection example

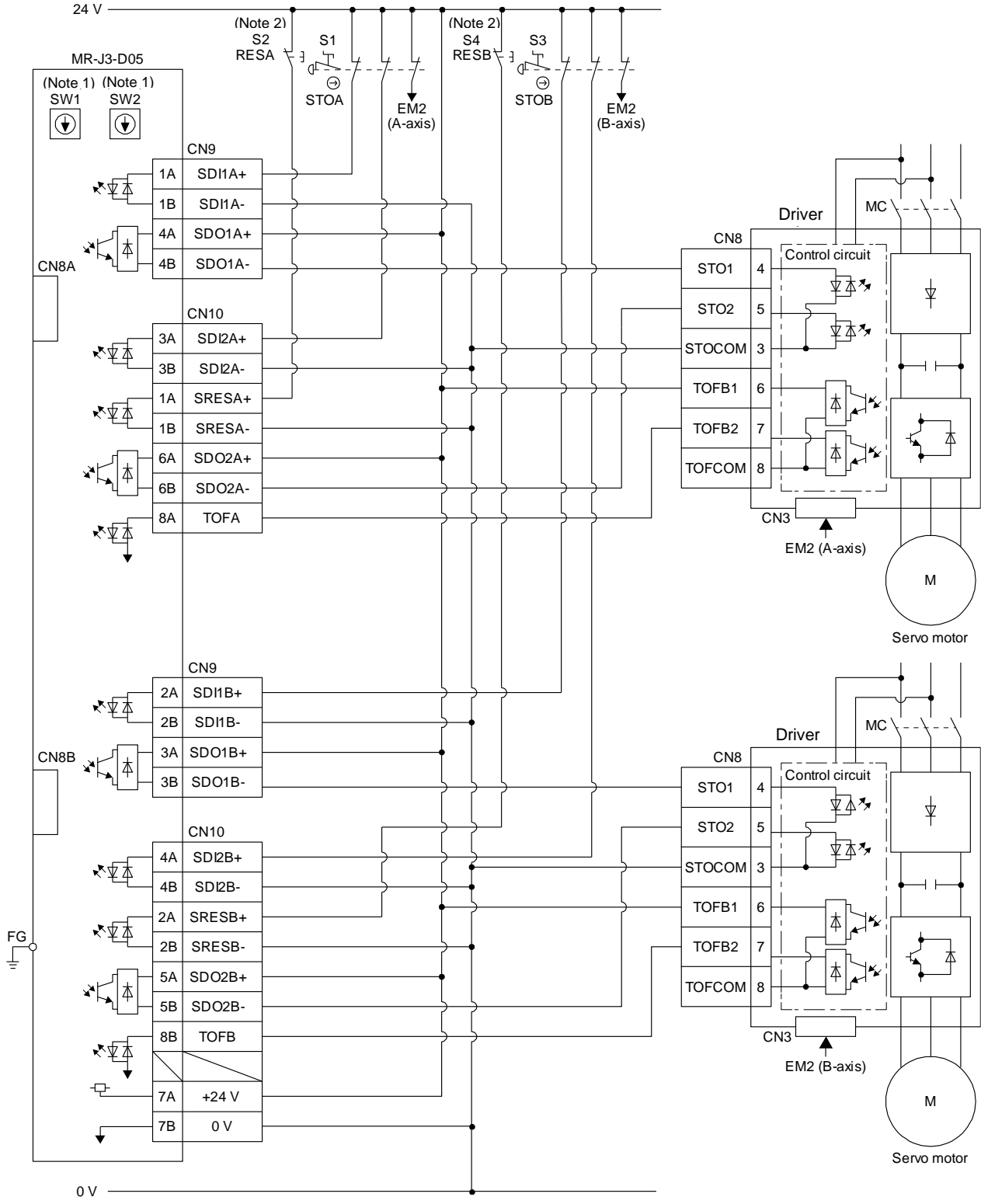

13. USING STO FUNCTION

Note 1. Set the delay time of STO output with SW1 and SW2. These switches for MR-J3-D05 of Mitsubishi Electric Corporation are located where denoted from the front panel.

Note 2. To release the STO state (base circuit shut-off), turn RESA and RESB on and turn them off.

(2) Basic operation example

STOA switch input is output to SDO1A and SDO2A of MR-J3-D05 (Mitsubishi Electric Corporation) and input to driver.

STOB switch input is output to SDO1B and SDO2B of MR-J3-D05 (Mitsubishi Electric Corporation) and input to the driver.

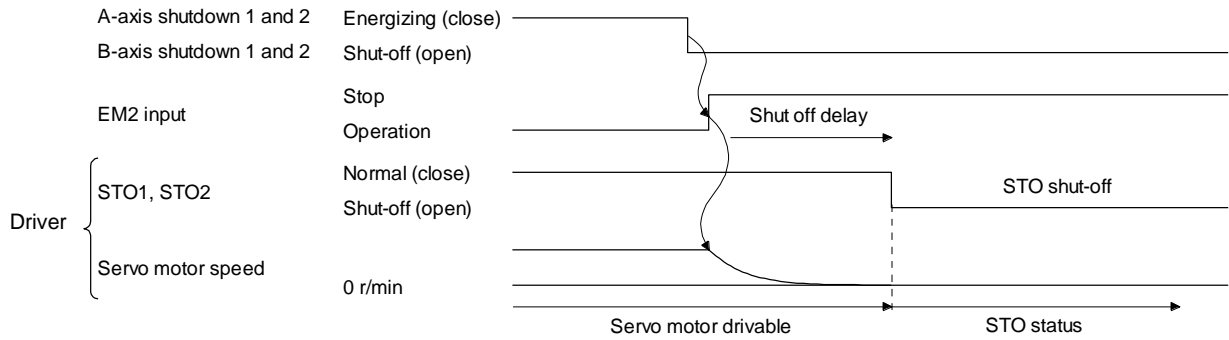

13. USING STO FUNCTION

13.3.3 External I/O signal connection example using an external safety relay unit

POINT

● This connection is for the source interface. For the other I/O signals, refer to the connection examples in section 3.2.

This connection example complies with the requirement of ISO/EN ISO 13849-1 category 3 PL d.

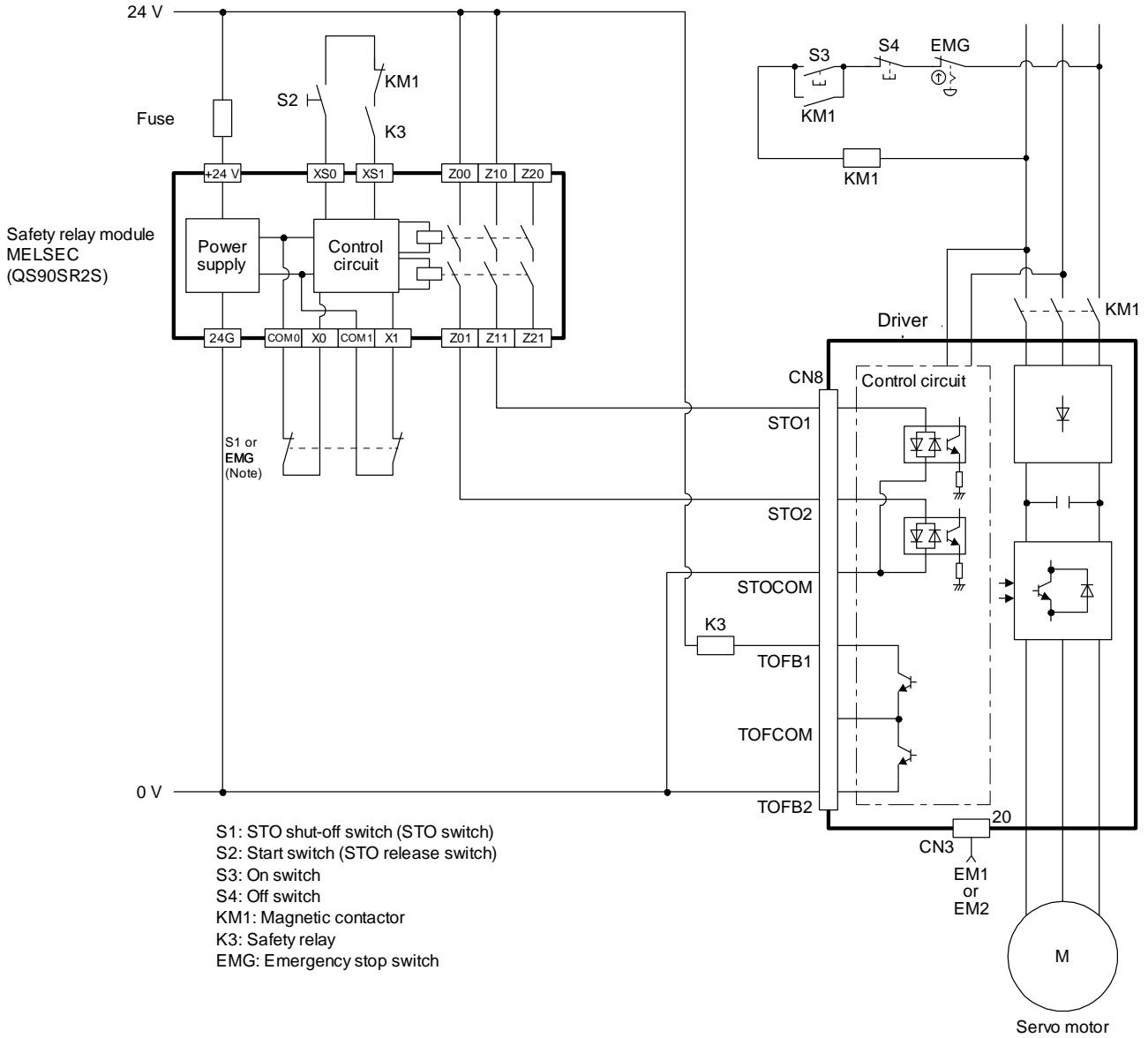

Note. To enable the STO function of the driver by using "Emergency switching off", change S1 to EMG. The stop category at this time is "0". If STO is turned off while the servo motor is rotating, [AL. 63 STO timing error] will occur.

13. USING STO FUNCTION

13.4 Detailed description of interfaces

This section provides the details of the I/O signal interfaces (refer to the I/O division in the table) given in section 13.2. Refer to this section and make connection with the external device.

13.4.1 Sink I/O interface

(1) Digital input interface DI-1

This is an input circuit whose photocoupler cathode side is input terminal. Transmit signals from sink (open-collector) type transistor output, relay switch, etc.

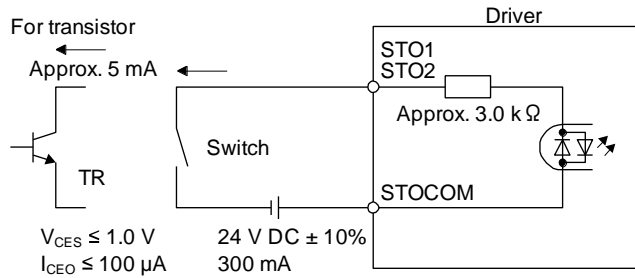

(2) Digital output interface DO-1

This is a circuit of collector output terminal of the output transistor. When the output transistor is turned on, collector terminal current will be applied for the output.

A lamp, relay or photocoupler can be driven. Install a diode (D) for an inductive load, or install an inrush current suppressing resistor (R) for a lamp load.

(Rated current: 40 mA or less, maximum current: 50 mA or less, inrush current: 100 mA or less) A maximum of 5.2 V voltage drop occurs in the driver.

(a) When outputting two STO states by using each TOFB

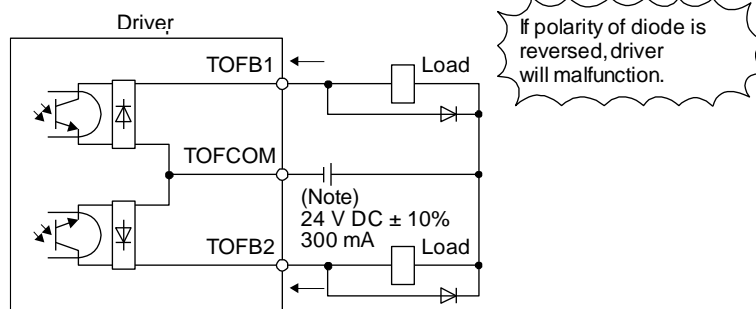

Note. If the voltage drop (maximum of 2.6 V) interferes with the relay operation, apply high voltage (maximum of 26.4 V) from external source.

13. USING STO FUNCTION

(b) When outputting two STO states by using one TOFB

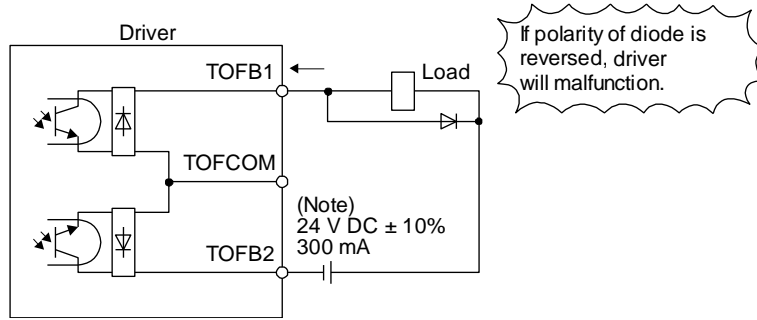

Note. If the voltage drop (maximum of 5.2 V) interferes with the relay operation, apply high voltage (maximum of 26.4 V) from external source.

13. USING STO FUNCTION

13.4.2 Source I/O interface

In this driver, source type I/O interfaces can be used.

(1) Digital input interface DI-1

This is an input circuit whose photocoupler anode side is input terminal. Transmit signals from source (open-collector) type transistor output, relay switch, etc.

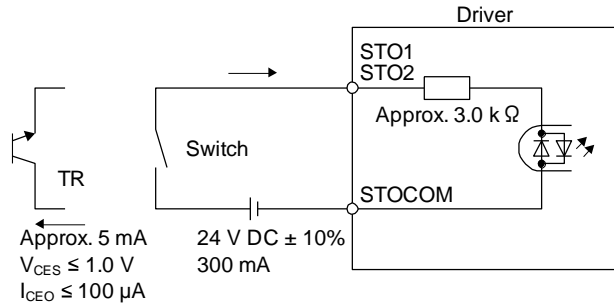

(2) Digital output interface DO-1

This is a circuit of emitter output terminal of the output transistor. When the output transistor is turned on, current will be applied from the output to a load.

A maximum of 5.2 V voltage drop occurs in the driver.

(a) When outputting two STO states by using each TOFB

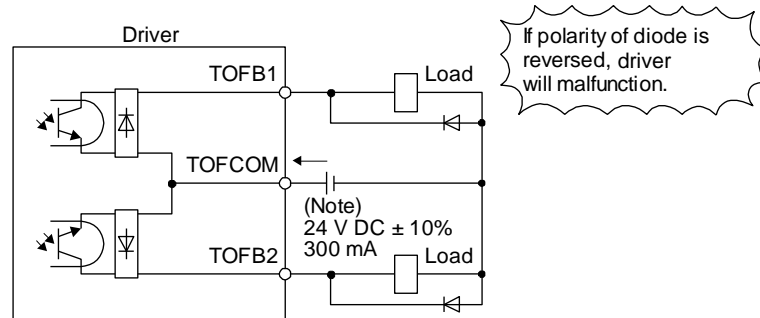

Note. If the voltage drop (maximum of 2.6 V) interferes with the relay operation, apply high voltage (maximum of 26.4 V) from external source.

(b) When outputting two STO states by using one TOFB

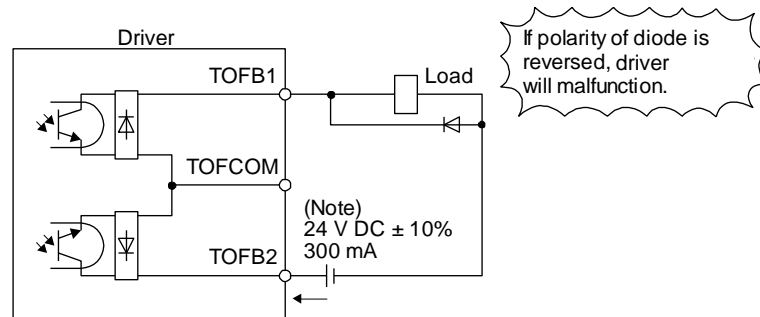

Note. If the voltage drop (maximum of 5.2 V) interferes with the relay operation, apply high voltage (maximum of 26.4 V) from external source.

14. APPLICATION OF FUNCTIONS

14. APPLICATION OF FUNCTIONS.....	2
14.1 Infinite feed function (setting degree).....	2

14. APPLICATION OF FUNCTIONS

14. APPLICATION OF FUNCTIONS

14.1 Infinite feed function (setting degree)

POINT
● This function can be used with the absolute position detection system.

When the unit of position data is set to degree in the profile mode, [AL. E3.1 Multi-revolution counter travel distance excess warning] does not occur and the home position is not erased even if the servo motor rotates 32768 rev or more in the same direction. Thus, the current position is restored after the power is cycled. For other command units, [AL. E3.1 Multi-revolution counter travel distance excess warning] occurs and the home position is erased if the servo motor rotates 32768 rev or more in the same direction.

The following shows differences depending on the position data unit when the servo motor rotates 32768 rev or more in the same direction.

Parameter	Name	Setting digit	Setting value	Unit	[AL. E3.1]	Home position erasure
PT01	Position data unit	_ x _ _	0	[mm]	It occurs.	Supported
			1	[inch]	It occurs.	Supported
			2	[degree]	It does not occur.	None
			3	[pulse]	It occurs.	Supported

15. SERVO MOTOR

15. SERVO MOTOR.....	2
15.1 Servo motor with a lock.....	2
15.1.1 Features	2
15.1.2 Characteristics of servo motor with a lock.....	4
15.2 Protection from oil and water	5
15.3 Cable.....	5
15.4 Rated speed of servo motor.....	5
15.5 Mounting connectors.....	6

15. SERVO MOTOR

15. SERVO MOTOR

15.1 Servo motor with a lock

15.1.1 Features

! CAUTION

- The lock is provided to prevent a drop at a power failure or servo alarm occurrence during vertical drive or to hold a shaft at a stop. Do not use it for normal braking (including braking at servo-lock).
- The lock has a time lag. Use the lock so that servo motor control starts after the lock has completely opened. Be sure to check the time lag of the locking with a real machine.
- Configure a lock circuit so that it is activated also by an external EMG stop switch.
- While the lock is opened, the motor may be raised to high temperature regardless of driving.
- The life will be shortened under sudden acceleration/deceleration conditions.

The servo motor with a lock can be used to prevent a drop in vertical lift applications or to ensure double safety at an emergency stop, for example. When operating the servo motor, supply power to the lock to release the lock. Switching power off enables the lock.

(1) Lock power supply

Prepare the following power supply for use with the lock only. The lock terminals (B1 and B2) have no polarity.

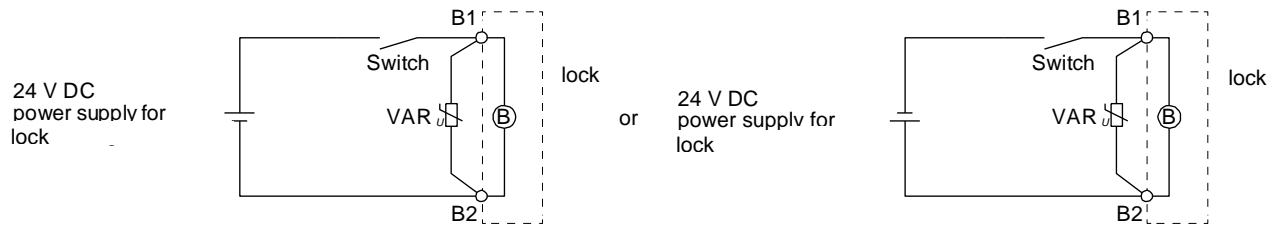

The surge absorber (VAR) must be installed between B1 and B2. When you use a diode for a surge absorber, the locking time will be longer.

(2) Sound generation

Though the brake lining may rattle during operation, it poses no functional problem.

If braking sounds, it may be improved by setting the machine resonance suppression filter in the driver parameters.

(3) Selection of surge absorbers for lock circuit

The following shows an example how to select a varistor with a surge absorber.

(a) Selection conditions

Item	Condition
Lock specification	R [Ω]: Resistance (Note) L [H]: Inductance (Note) Vb [V]: Power supply voltage
Desired suppression voltage	Vs [V] or less
Durable surge application time	N times

Note. Refer to section 15.1.2

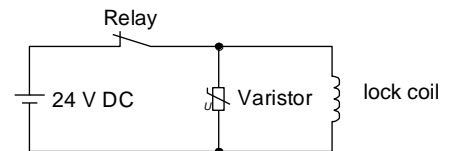

15. SERVO MOTOR

(b) Tentative selection and verification of surge absorber

1) Maximum allowable circuit voltage of varistor

Tentatively select a varistor whose maximum allowable voltage is larger than V_b [V].

2) Lock current (I_b)

$$I_b = \frac{V_b}{R} \text{ [A]}$$

3) Energy (E) generated by lock coil

$$E = \frac{L \times I_b^2}{2} \text{ [J]}$$

4) Varistor limit voltage (V_i)

From the energy (E) generated in the lock coil and the varistor characteristic diagram, calculate the varistor limit voltage (V_i) when the lock current (I_b) flows into the tentatively selected varistor during opening of the circuit. Please refer to the varistor characteristic diagram to the varistor manufacturer.

The desired suppressed voltage (V_s) is the sum of the 24 VDC \pm 10% used and the other devices (relays etc. *Check the maximum contact voltage of the relay) used by the user. Please confirm the specification of the equipment to be used.

V_i is favorable when the varistor limit voltage (V_i) [V] is smaller than the desired suppressed voltage (V_s) [V].

If V_i is not smaller than V_s , reselect a varistor or improve the withstand voltage of devices.

Regarding the characteristics characteristic diagram, specification, selection of the varistor, it is necessary to check with the varistor manufacturer.

5) Surge current width (τ)

Given that the varistor absorbs all energies, the surge current width (τ) will be as follows.

$$\tau = \frac{E}{V_i \times I_b} \text{ [S]}$$

6) Examining surge life of varistor

From the varistor characteristic diagram, the guaranteed current value (I_p) in which the number of the surge application life is N at the surge current width (τ). Calculate the guaranteed current value (I_p) ratio to lock current (I_b).

If an enough margin is ensured for I_p/I_b , the number of the surge application life N [time] can be considered as favorable.

(4) Others

A leakage magnetic flux will occur at the shaft end of the servo motor equipped with a lock. Note that chips, screws, etc. are attracted.

15. SERVO MOTOR

15.1.2 Characteristics of servo motor with a lock

	CAUTION	<ul style="list-style-type: none"> ● The lock is provided to prevent a drop at a power failure or servo alarm occurrence during vertical drive or to hold a shaft at a stop. Do not use it for normal braking (including braking at servo-lock). ● Before performing the operation, be sure to confirm that the lock operates properly. ● The operation time of the lock differs depending on the power supply circuit you use. Be sure to check the operation delay time with a real machine.
---	---------	---

The characteristics (reference value) of the lock provided for the servo motor with a lock are indicated below.

Item	Servo motor		LE-□-B			
			T6 (100W)	T7 (200W)	T8 (400W)	T9 (750W)
Type (Note 1)	Spring actuated type safety lock					
Rated voltage (Note 4)	24 V DC ⁰ / _{-10%}					
Power consumption [W] at 20 °C			6.3	7.9	10	
Coil resistance (Note 6) [Ω]			91.0	73.0	57.0	
Inductance (Note 6) [H]			0.15	0.18	0.13	
Lock static friction torque [N•m]			0.32	1.3	2.4	
Release delay time (Note 2) [s]			0.03	0.03	0.04	
Locking delay time (Note 2) [s]	DC off		0.01	0.02	0.02	
Permissible locking work	Per locking [J]		5.6	22	64	
	Per hour [J]		56	220	640	
Lock looseness at servo motor shaft (Note 5) [degrees]			2.5	1.2	0.9	
Lock life (Note 3)	Number of lockings [times]	20000				
	Work per locking [J]		5.6	22	64	
Selection example of surge absorbers to be used (Note 7, 8)	For the suppressed voltage 125 V	TND20V-680KB				
	For the suppressed voltage 350 V	TND10V-221KB				

- Note
1. There is no manual release mechanism. When it is necessary to hand-turn the servo motor shaft for machine centering, etc., use a separate 24 V DC power supply to release the lock electrically.
 2. The value for initial on gap at 20 °C.
 3. The lock gap will increase as the brake lining wears, but the gap is not adjustable.
The lock life indicated is the number of locking cycles after which adjustment will be required.
 4. Always prepare a power supply exclusively used for the lock.
 5. These are design values. These are not guaranteed values.
 6. These are measured values. These are not guaranteed values.
 7. Select the lock control relay properly, considering the characteristics of the lock and surge absorber. When you use a diode for a surge absorber, the locking time will be longer.
 8. Manufactured by Nippon Chemi-Con Corporation.

15. SERVO MOTOR

15.2 Protection from oil and water

- (1) Do not use the servo motor with its cable soaked in oil or water.

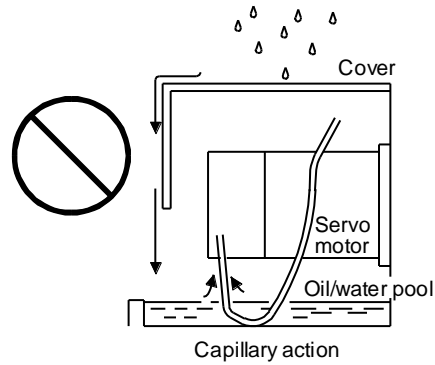

- (2) If oil such as cutting oil drops on the servo motor, the sealant, packing, cable and others may be affected depending on the oil type.

15.3 Cable

The standard motor and encoder cables routed from the servo motor should be fixed to the servo motor to keep them unmovable. Otherwise, the cable may disconnect. In addition, do not modify the connectors, terminals and others at the ends of the cables.

15.4 Rated speed of servo motor

The rated speed of servo motor (100~750W) is 3000[r/min].

15. SERVO MOTOR

15.5 Mounting connectors

If the connector is not fixed securely, it may come off or may not produce a splash-proof effect during operation.

To achieve the IP rating IP65, pay attention to the following points and install the connectors.

- (1) When screwing the connector, hold the connector still and gradually tighten the screws in a crisscross pattern.

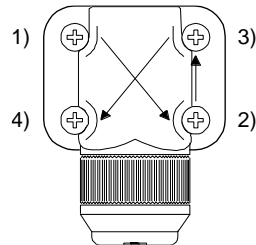

Connector for power supply, connector for encoder

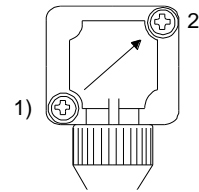

Connector for lock encoder

- (2) Tighten the screws evenly. Tightening torques are as indicated below.

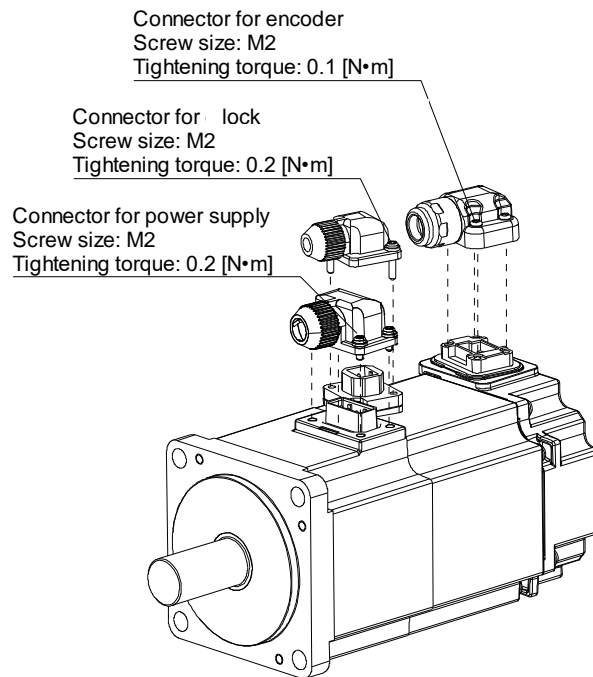

- (3) The servo motor fitting part of each connector is provided with a splash-proof seal (O ring). When mounting a connector, use care to prevent the seal (O ring) from dropping and being pinched. If the seal (O ring) has dropped or is pinched, a splash-proof effect is not produced.

16. HOW TO USE THE POINT TABLE

16. HOW TO USE THE POINT TABLE	2
16.1 Specification list	3
16.2 Switching power on for the first time	4
16.3 Switching power on for the first time Point table mode (pt)	6
16.3.1 Point table mode (pt)	6
16.3.2 Automatic operation using point table	6
16.4 Jog mode (jg)	24
16.5 Point table setting method	26
16.5.1 Point table setting method with Setup software (MR Configurator2™)	26
16.5.2 Point table setting method with objects	29

16. HOW TO USE THE POINT TABLE

16. HOW TO USE THE POINT TABLE

POINT
● For the home position return, refer to chapter 18,19,20.

See the following table for the No. of each object mentioned in this chapter.

Object	No.	
	EtherCAT	PROFINET
Modes of operation	Index: 6060h	PNU: 24672, Sub: 0
Controlword	Index: 6040h	PNU: 24640, Sub: 0
Statusword	Index: 6041h	PNU: 24641, Sub: 0
Profile velocity	Index: 6081h	PNU: 24705, Sub: 0
Profile acceleration	Index: 6083h	PNU: 24707, Sub: 0
Profile deceleration	Index: 6084h	PNU: 24708, Sub: 0
Target point table	Index: 2D60h	PNU: 11616, Sub: 0
Status DO 1	Index: 2D11h	PNU: 11537, Sub: 0
Status DO 5	Index: 2D15h	PNU: 11541, Sub: 0
Point actual value	Index: 2D69h	PNU: 11625, Sub: 0
M code actual value	Index: 2D6Ah	PNU: 11626, Sub: 0
Point table _ _ _	Index: 2801h to 28FFh	PNU: 10241 to 10495, Sub: 0

16. HOW TO USE THE POINT TABLE

16.1 Specification list

Item		Description	
Operational specifications		Positioning with specification of point table No. (255 points)	
Position command input (Note 1)		Set in the point table. Setting range of feed length per point: -999999 to 999999 [$\times 10^{5\text{TM}}$ μm], -99.9999 to 99.9999 [$\times 10^{5\text{TM}}$ inch], -999999 to 999999 [pulse]	
Speed command input		Set the acceleration/deceleration time constants in the point table. Set the S-pattern acceleration/deceleration time constants with [Pr. PT51].	
System		Signed absolute position command method/relative position command method	
Torque limit		Limits the servo motor torque.	
Control mode	Point table mode (pt)	Each positioning operation	Point table No. input method Operates each positioning based on position command and speed command.
		Automatic continuous positioning operation	Varying-speed operation (2 to 255 speeds)/automatic continuous positioning operation (2 to 255 points)/ Automatic continuous operation to a point table selected at startup/automatic continuous operation to the point table No. 1
	Jog mode (jg)	JOG operation	Executes an inching operation via network.
Homing mode (hm)	Dog type (Rear end detection, Z-phase reference)		For the descriptions of the home position return types, refer to chapter 18,19,20.
	Count type (Front end detection, Z-phase reference)		
	Data set type		
	Stopper type (Stopper position reference)		
	Dog type (Rear end detection, rear end reference)		
	Count type (Front end detection, front end reference)		
	Dog cradle type		
	Dog type last Z-phase reference (Note 2)		
	Dog type front end reference		
	Dogless Z-phase reference (Note 2)		
	Home position ignorance (servo-on position as home position)		
	Homing on positive home switch and index pulse (method 3)		
	Homing on positive home switch and index pulse (method 4)		
	Homing on negative home switch and index pulse (method 5)		
Homing on negative home switch and index pulse (method 6)			

16. HOW TO USE THE POINT TABLE

Item		Description
Control mode	Homing mode (hm)	Homing on home switch and index pulse (method 7)
		Homing on home switch and index pulse (method 8)
		Homing on home switch and index pulse (method 11)
		Homing on home switch and index pulse (method 12)
		Homing without index pulse (method 19)
		Homing without index pulse (method 20)
		Homing without index pulse (method 21)
		Homing without index pulse (method 22)
		Homing without index pulse (method 23)
		Homing without index pulse (method 24)
		Homing without index pulse (method 27)
		Homing without index pulse (method 28)
		Homing on index pulse (method 33)
		Homing on index pulse (method 34)
		Homing on current position (method 35)
		Homing on current position (method 37)
Automatic positioning to home position function		High-speed automatic positioning to a defined home position
Other functions		Absolute position detection/external limit switch/software stroke limit
Note	STM is the ratio to the setting value of the position data. STM can be changed with [Pr. PT03 Feeding function selection].	
1.		

For the descriptions of the home position return types, refer to chapter 18,19,20.

16.2 Switching power on for the first time

POINT
<ul style="list-style-type: none"> ● Set [Pr. PA01] to "___6" (Positioning mode (point table method)). ● When using EtherCAT, set the mapping objects of 3rd RxPDO map (1602h) and 2nd TxPDO map (1A01h) in the PDO mapping. For details, refer to 18.3. ● When using PROFINET, set the communication format to Telegram 103. For details, refer to section 20.

16. HOW TO USE THE POINT TABLE

When switching power on for the first time, follow this section to make a startup.

Startup procedure

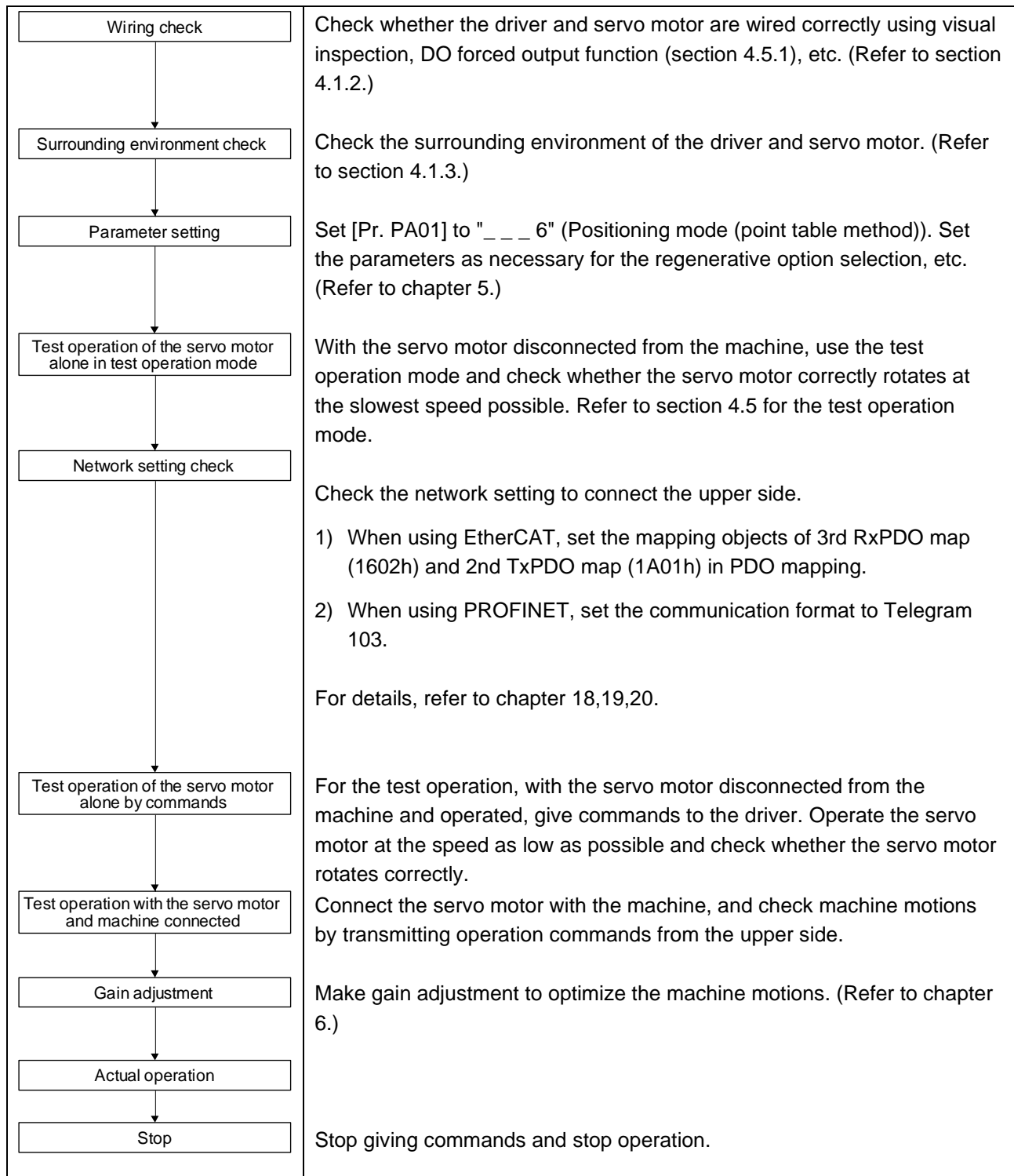

16. HOW TO USE THE POINT TABLE

16.3 Switching power on for the first time Point table mode (pt)

16.3.1 Point table mode (pt)

Set point tables in advance, and select any point table in "Target point table" to start operation with "Controlword bit 4 (New set-point)". The auxiliary function of the point table enables to select absolute position command method and relative position command method.

(1) Absolute position command method

As position data, set the target address to be reached.

Setting range: -999999 to 999999 [$\times 10^{\text{STM}}$ μm] (STM = Feed length multiplication [Pr. PT03])

-999999 to 999999 [$\times 10^{(\text{STM}-4)}$ inch] (STM = Feed length multiplication [Pr. PT03])

-999999 to 999999 [pulse]

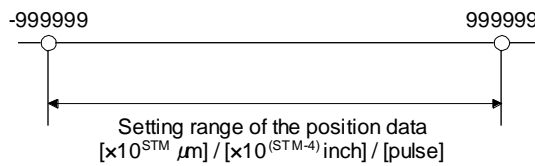

(2) Relative position command method

As position data, set the travel distance from the current address to the target address.

Setting range: -999999 to 999999 [$\times 10^{\text{STM}}$ μm] (STM = Feed length multiplication [Pr. PT03])

-999999 to 999999 [$\times 10^{(\text{STM}-4)}$ inch] (STM = Feed length multiplication [Pr. PT03])

-999999 to 999999 [pulse]

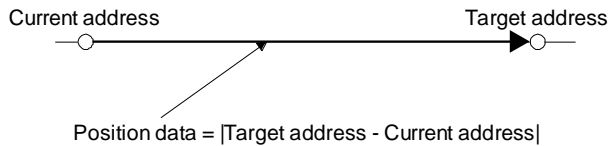

16.3.2 Automatic operation using point table

Select absolute position command method or relative position command method in the auxiliary function of the point table to use this function.

(1) Point table

POINT	<p>● Refer to section 18.5 for the setting of the point table.</p>
-------	--

16. HOW TO USE THE POINT TABLE

Set the point table values using Setup software (MR Configurator2™) or "Point table 001 to 255".

Set the position data, servo motor speed, acceleration time constant, deceleration time constant, dwell time, auxiliary function, and M code to the point table.

To use the point table with the absolute position command method, set "0", "1", "8", or "9" to the auxiliary function. To use the point table with the relative position command method, set "2", "3", "10", or "11" to the auxiliary function.

When you set a value outside the setting range to the point table, the set value will be clamped with the maximum or minimum value. If the value becomes out of the range because of the changes in the command unit or the connected servo motor, [AL. 37] will occur.

Item	Setting range	Unit	Description
Position data	-999999 to 999999 (Note 1)	$\times 10^{\text{STM}} \mu\text{m}$ $\times 10^{(\text{STM}-4)} \text{inch}$ pulse	(1) When using this point table with the absolute position command method Set the target address (absolute value). (2) When using this point table with the relative position command method Set the travel distance. A "-" sign indicates a reverse rotation command.
Servo motor speed	0 to permissible speed	0.01 r/min 0.01 mm/s	Set the command speed of the servo motor for execution of positioning. The setting value must be the instantaneous permissible speed or less of the servo motor used. When actually driving the motor, any decimal places are truncated.
Acceleration time constant	0 to 20000	ms	Set a time for the servo motor to reach the rated speed.
Deceleration time constant	0 to 20000	ms	Set a time for the servo motor to stop from the rated speed.
Dwell time	0 to 20000	ms	Set the dwell time. To disable the dwell time, set "0" or "2" to the auxiliary function. To perform a continuous operation, set "1", "3", "8", "9", "10", or "11" to the auxiliary function and "0" to the dwell time. When the dwell time is set, a positioning of the next point table will be started after the positioning of the selected data is completed, and the set dwell time has elapsed.
Auxiliary function	0 to 3, 8 to 11		Set the auxiliary function. (1) When using this point table with the absolute position command method 0: Automatic operation for a selected point table is performed. 1: Automatic continuous operation is performed without a stop to the next point table. 8: Automatic continuous operation is performed without a stop to the point table selected at start-up. 9: Automatic continuous operation is performed without stopping a point table No. 1. (2) When using this point table with the relative position command method 2: Automatic operation for a selected point table is performed. 3: Automatic continuous operation is performed without a stop to the next point table. 10: Automatic continuous operation for a point table selected at start-up is performed. 11: Automatic continuous operation is performed without stopping a point table No. 1. When an opposite rotation direction is set, the servo motor rotates in the opposite direction after smoothing zero (command output) is confirmed. Setting "1" or "3" to point table No. 255 results in an error. Refer to (4) (b) in this section for details.
M code	0 to 99		Set a code to output at the completion of positioning. M code can be read with "M code actual value".

Note 1	When the unit of the position data is μm or inch, the location of the decimal point is changed according to the STM setting.
-----------	---

16. HOW TO USE THE POINT TABLE

(2) Parameter setting

Set the following parameters to perform automatic operation.

(a) Rotation direction selection ([Pr. PA14])

Select the servo motor rotation direction when "Controlword bit 4 (New set-point)" is switched on.

[Pr. PA14] setting	Servo motor rotation direction "Controlword bit 4 (New set-point)" on
0	CCW rotation with + position data CW rotation with - position data
1	CW rotation with + position data CCW rotation with - position data

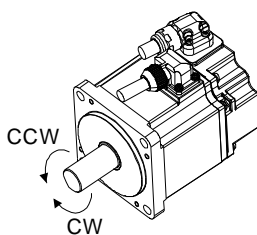

(b) Position data unit ([Pr. PT01])

Set the unit of the position data.

[Pr. PT01] setting	Position data unit
_ 0 _ _	mm
_ 1 _ _	inch
_ 3 _ _	pulse

(c) Feed length multiplication ([Pr. PT03])

Set the feed length multiplication factor (STM) of the position data.

[Pr. PT03] setting	Position data input range		
	[mm]	[inch]	[pulse] (Note)
___ 0	- 999.999 to + 999.999	- 99.9999 to + 99.9999	- 999999 to + 999999
___ 1	- 9999.99 to + 9999.99	- 999.999 to + 999.999	
___ 2	- 99999.9 to + 99999.9	- 9999.99 to + 9999.99	
___ 3	- 999999 to + 999999	- 99999.9 to + 99999.9	

Note. The feed length multiplication setting ([Pr. PT03]) is not applied to the unit multiplication factor.

Adjust the unit multiplication factor in the electronic gear setting ([Pr. PA06] and [Pr. PA07]).

(3) Operation

Selecting the point table with "Target point table" and switching on "Controlword bit 4 (New set-point)" starts positioning to the position data at the set speed, acceleration time constant and deceleration time constant.

Item	Object to be used	Setting
Point table mode (pt) selection	Modes of operation	Set "-101".
Point table selection	Target point table	Set the point table No. to use.
Start	Controlword	Switch on "Controlword bit 4 (New set-point)".

16. HOW TO USE THE POINT TABLE

(4) Automatic operation timing chart

(a) Automatic individual positioning operation

While the servo motor is stopped under servo-on state, switching on "Controlword bit 4 (New set-point)" starts the automatic positioning operation.

The following shows a timing chart.

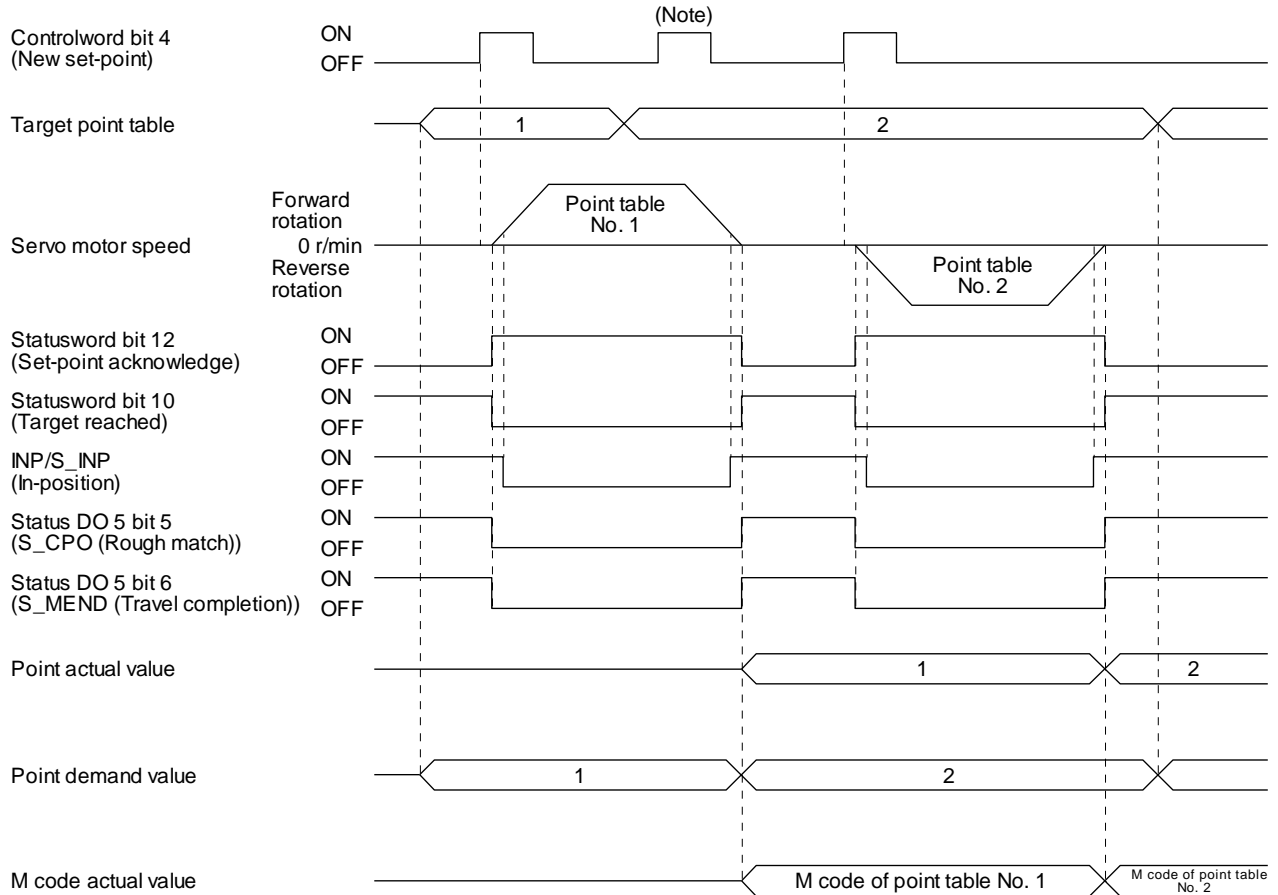

No te.	Switching on "Controlword bit 4 (New set-point)" is invalid during the servo motor rotation.
--------	--

16. HOW TO USE THE POINT TABLE

(b) Automatic continuous positioning operation

By merely selecting a point table and switching on "Controlword bit 4 (New set-point)", the operation can be performed in accordance with the point tables having consecutive numbers.

The following shows a timing chart.

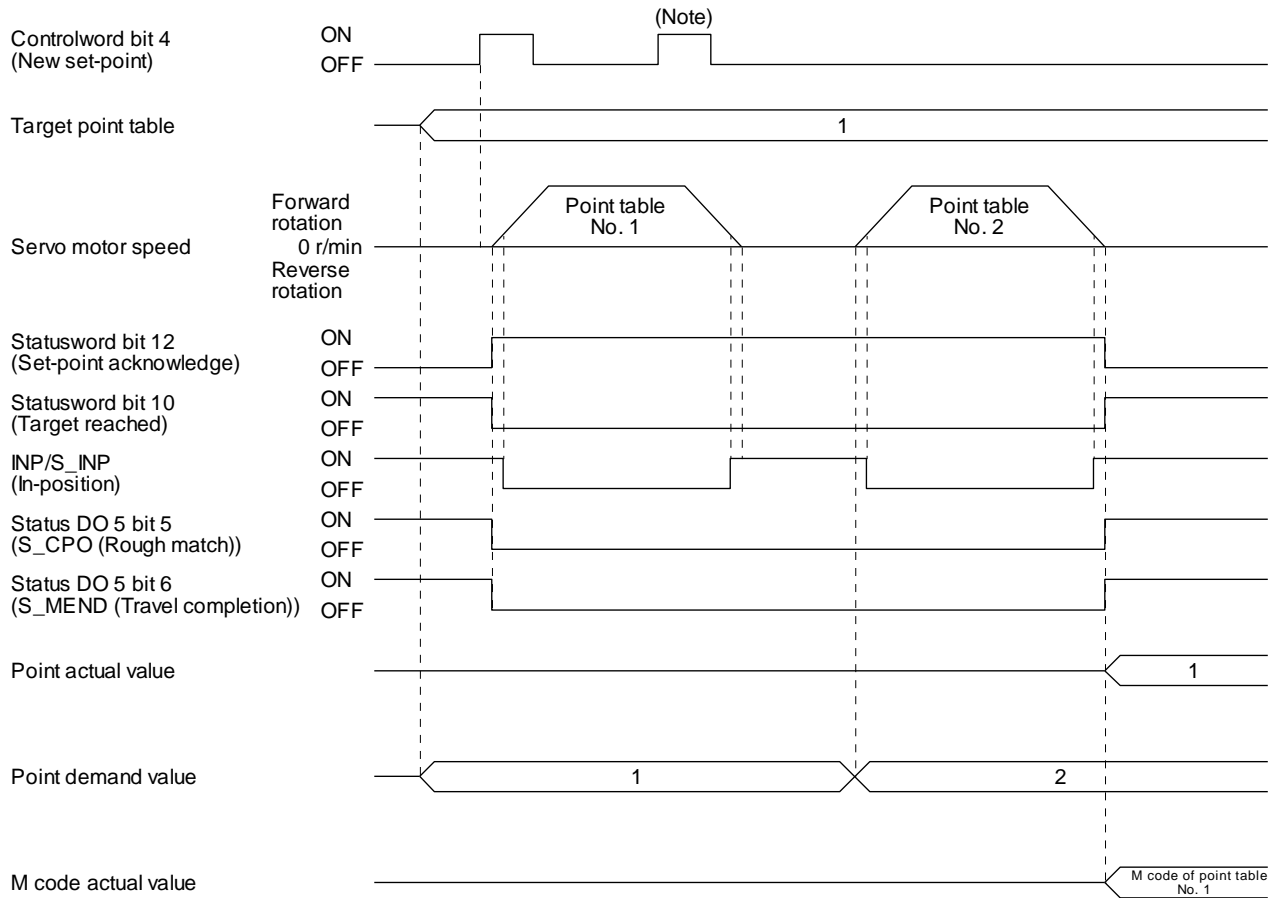

No te.	Switching on "Controlword bit 4 (New set-point)" is invalid during the servo motor rotation.
--------	--

By specifying the absolute position command or the relative position command in the auxiliary function of the point table, the automatic continuous operation can be performed.

The following shows how to set.

Point table setting		
Dwell time	Auxiliary function	
	When the position data is absolute value	When the position data is relative value
1 or more	1	3

16. HOW TO USE THE POINT TABLE

1) Positioning in a single direction

The following shows an operation example with the set values listed in the table below.

In this example, point table No. 1 and No. 3 are set to the absolute position command method, and point table No. 2 is set to the relative position command method.

Point table No.	Position data [10 ^{STM} μm]	Servo motor speed [r/min]	Acceleration time constant [ms]	Deceleration time constant [ms]	Dwell time [ms]	Auxiliary function	M code
1	5.00	3000.00	100	150	100	1	05
2	5.00	2000.00	150	200	200	3	10
3	15.00	1000.00	300	100	Disabled	0 (Note)	15

Note. Be sure to set "0" or "2" to the auxiliary function of the last point table of the consecutive point tables.

0: When using the point table with the absolute position command method

2: When using the point table with the relative position command method

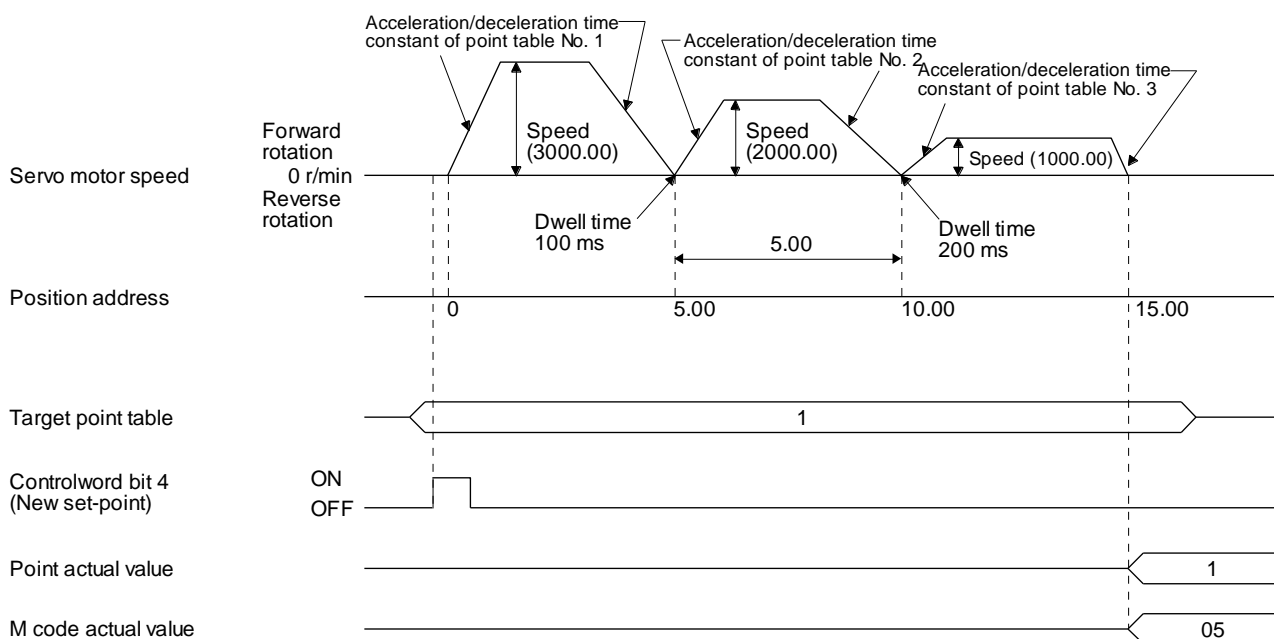

16. HOW TO USE THE POINT TABLE

2) Positioning in the reverse direction midway

The following shows an operation example with the set values listed in the table below.

In this example, point table No. 1 and No. 3 are set to the absolute position command method, and point table No. 2 is set to the relative position command method.

Point table No.	Position data [10 ^{STM} μm]	Servo motor speed [r/min]	Acceleration time constant [ms]	Deceleration time constant [ms]	Dwell time [ms]	Auxiliary function	M code
1	5.00	3000.00	100	150	100	1	05
2	7.00	2000.00	150	200	200	3	10
3	8.00	1000.00	300	100	Disabled	0 (Note)	15

Note. Be sure to set "0" or "2" to the auxiliary function of the last point table of the consecutive point tables.

0: When using the point table with the absolute position command method

2: When using the point table with the relative position command method

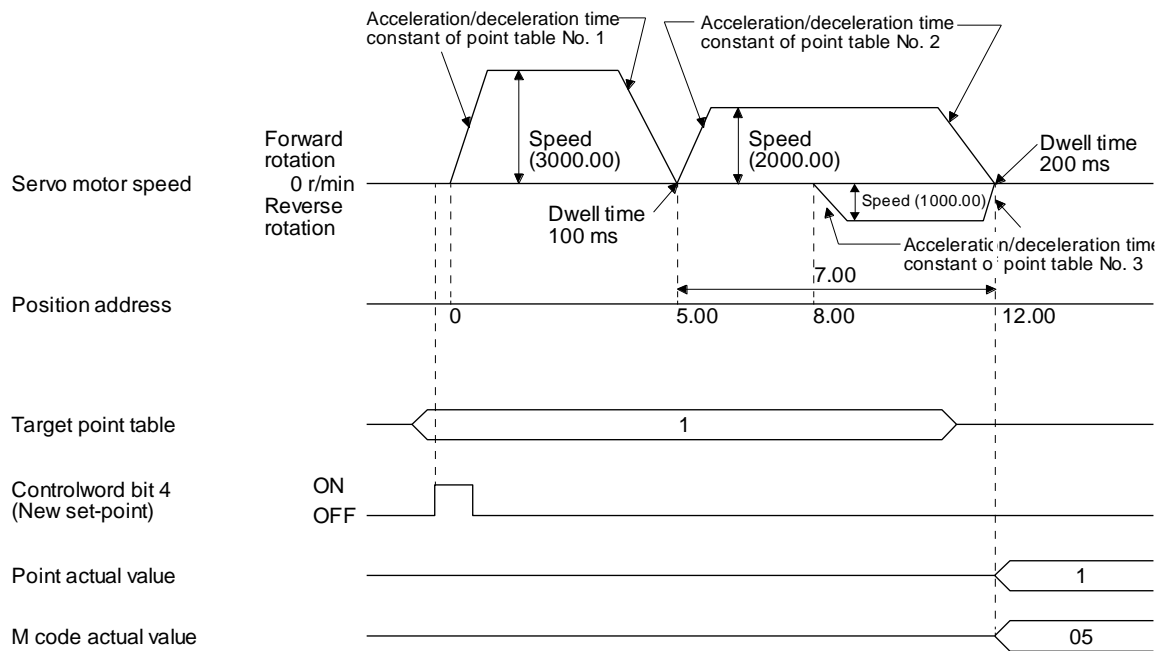

16. HOW TO USE THE POINT TABLE

(c) Varying-speed operation

By setting the auxiliary function of the point table, the servo motor speed during positioning can be changed. Point tables are used by the number of the set speed.

Set "1" or "3" to the auxiliary function to execute the positioning at the speed set in the following point table.

At this time, the position data selected at start is enabled, and the acceleration/deceleration time constant set in the next and subsequent point tables is disabled.

By setting "1" or "3" to auxiliary functions until point table No. 254, the operation can be performed at maximum 255 speeds.

Be sure to set "0" or "2" to the auxiliary function of the last point table.

To perform varying-speed operation, be sure to set "0" to the dwell time.

Setting "1" or more enables the automatic continuous positioning operation.

The following table shows an example of setting.

Point table No.	Dwell time [ms] (Note 1)	Auxiliary function	Varying-speed operation
1	0	1	Consecutive point table data
2	0	3	
3	Disabled	0 (Note 2)	
4	0	3	Consecutive point table data
5	0	1	
6	Disabled	2 (Note 2)	

Note 1. Be sure to set "0".

2. Be sure to set "0" or "2" to the auxiliary function of the last point table of the consecutive point tables.

16. HOW TO USE THE POINT TABLE

1) Positioning in a single direction

The following shows an operation example with the set values listed in the table below.

In this example, point table No. 1 and No. 3 are set to the absolute position command method, and point table No. 2 is set to the relative position command method.

Point table No.	Position data [10 ^{STM} μm]	Servo motor speed [r/min]	Acceleration time constant [ms]	Deceleration time constant [ms]	Dwell time [ms] (Note 1)	Auxiliary function	M code
1	5.00	3000.00	100	150	0	1	05
2	3.00	2000.00	Disabled	Disabled	0	3	10
3	10.00	1000.00	Disabled	Disabled	0	1	15
4	6.00	500.00	Disabled	Disabled	Disabled	2 (Note 2)	20

Note 1. Be sure to set "0".

2. Be sure to set "0" or "2" to the auxiliary function of the last point table of the consecutive point tables.

0: When using the point table with the absolute position command method

2: When using the point table with the relative position command method

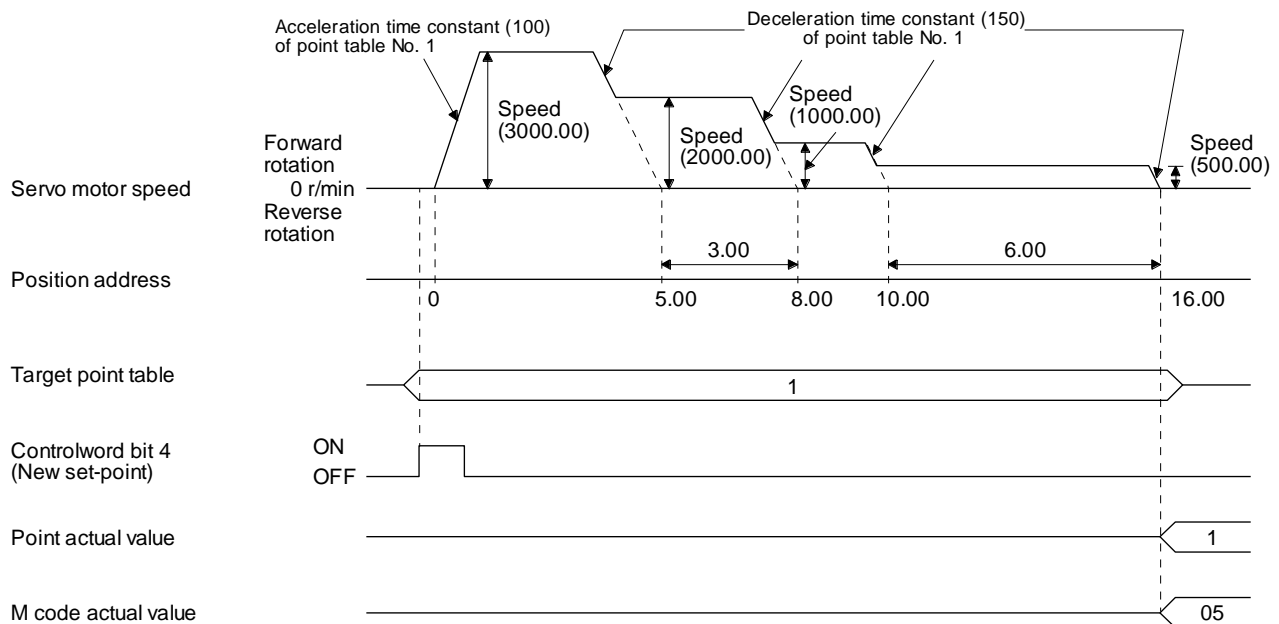

16. HOW TO USE THE POINT TABLE

2) Positioning in the reverse direction midway

The following shows an operation example with the set values listed in the table below.

In this example, point table No. 1 and No. 3 are set to the absolute position command method, and point table No. 2 is set to the relative position command method.

Point table No.	Position data [10 ^{STM} μm]	Servo motor speed [r/min]	Acceleration time constant [ms]	Deceleration time constant [ms]	Dwell time [ms] (Note 1)	Auxiliary function	M code
1	5.00	3000.00	100	150	0	1	05
2	7.00	2000.00	Disabled	Disabled	0	3	10
3	8.00	1000.00	Disabled	Disabled	Disabled	0 (Note 2)	15

Note 1. Be sure to set "0".

2. Be sure to set "0" or "2" to the auxiliary function of the last point table of the consecutive point tables.

0: When using the point table with the absolute position command method

2: When using the point table with the relative position command method

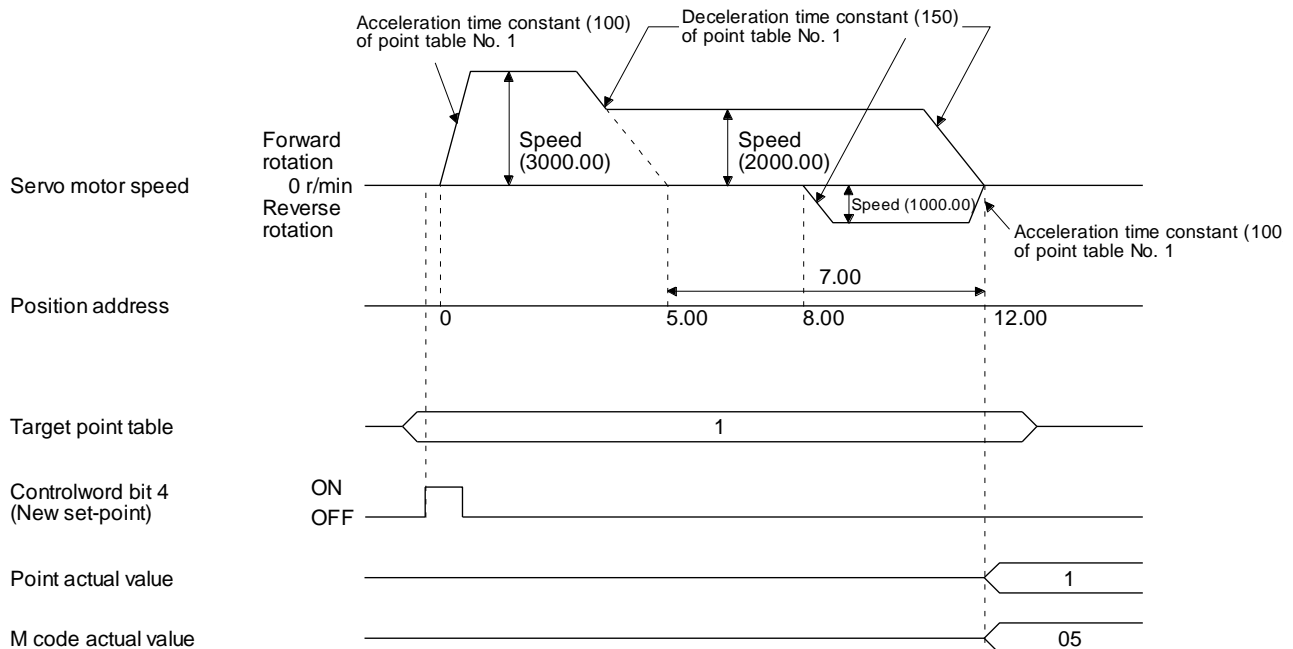

16. HOW TO USE THE POINT TABLE

(d) Automatic repeat positioning operation

By setting the auxiliary function of the point table, the operation pattern of the set point table No. can be returned to, and the positioning operation can be performed repeatedly.

Setting "8" or "10" to the auxiliary function performs an automatic continuous operation or a varying-speed operation until that point table, and after the completion of positioning, performs the operation again from the operation pattern of the point table No. used at start-up.

Setting "9" or "11" to the auxiliary function performs an automatic continuous operation or a varying-speed operation until that point table, and after the completion of positioning, performs the operation again from the operation pattern of point table No. 1.

1) Automatic repeat positioning operation by absolute position command method

Example 1. Operations when "8" is set to the auxiliary function of point table No. 4

Point table No.	Position data [10 ^{STM} μm]	Servo motor speed [r/min]	Acceleration time constant [ms]	Deceleration time constant [ms]	Dwell time [ms]	Auxiliary function	M code
1	4.00	1500.00	200	100	150	1	01
2	5.00	3000.00	100	150	100	1	05
3	5.00	2000.00	150	200	200	3	10
4	15.00	1000.00	300	100	150	8	15

Operation sequence

- 1) Starting with point table No. 2
- 2) Executing point table No. 3
- 3) Executing point table No. 4
- 4) Executing again point table No. 2 used at start-up when "8" is set to the auxiliary function of point table No. 4
- 5) Repeating the above execution in the sequence of 2) to 3) to 4) to 2) to 3) to 4)

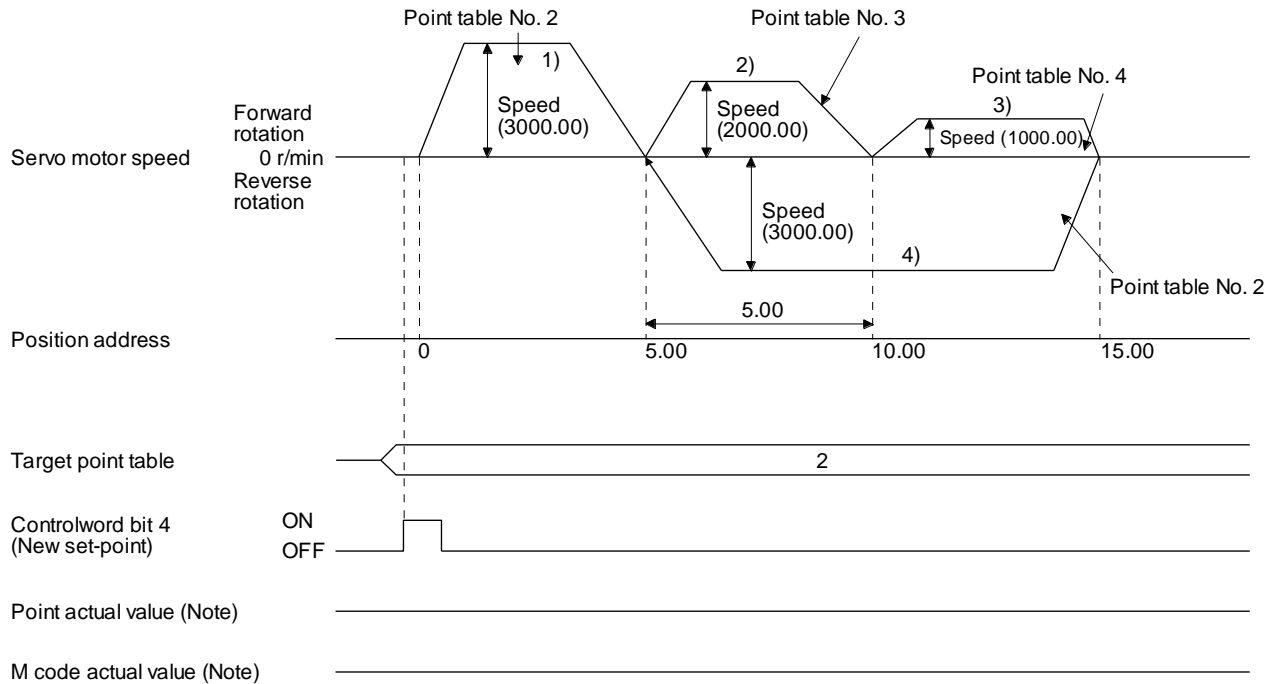

Note. "Point actual value" and "M code actual value" are not outputted in an automatic continuous operation.

16. HOW TO USE THE POINT TABLE

Example2. Operations when "9" is set to the auxiliary function of point table No. 3

Point table No.	Position data [10 ⁵ TM μm]	Servo motor speed [r/min]	Acceleration time constant [ms]	Deceleration time constant [ms]	Dwell time [ms]	Auxiliary function	M code
1	0.00	3000.00	100	150	100	1	05
2	5.00	2000.00	150	200	200	1	10
3	15.00	1000.00	300	100	150	9	15

Operation sequence

- 1) Starting with point table No. 2
- 2) Executing point table No. 3
- 3) Executing point table No. 1 when "9" is set to the auxiliary function of point table No. 3
- 4) Repeating the above execution in the sequence of 1) to 2) to 3) to 1) to 2) to 3)

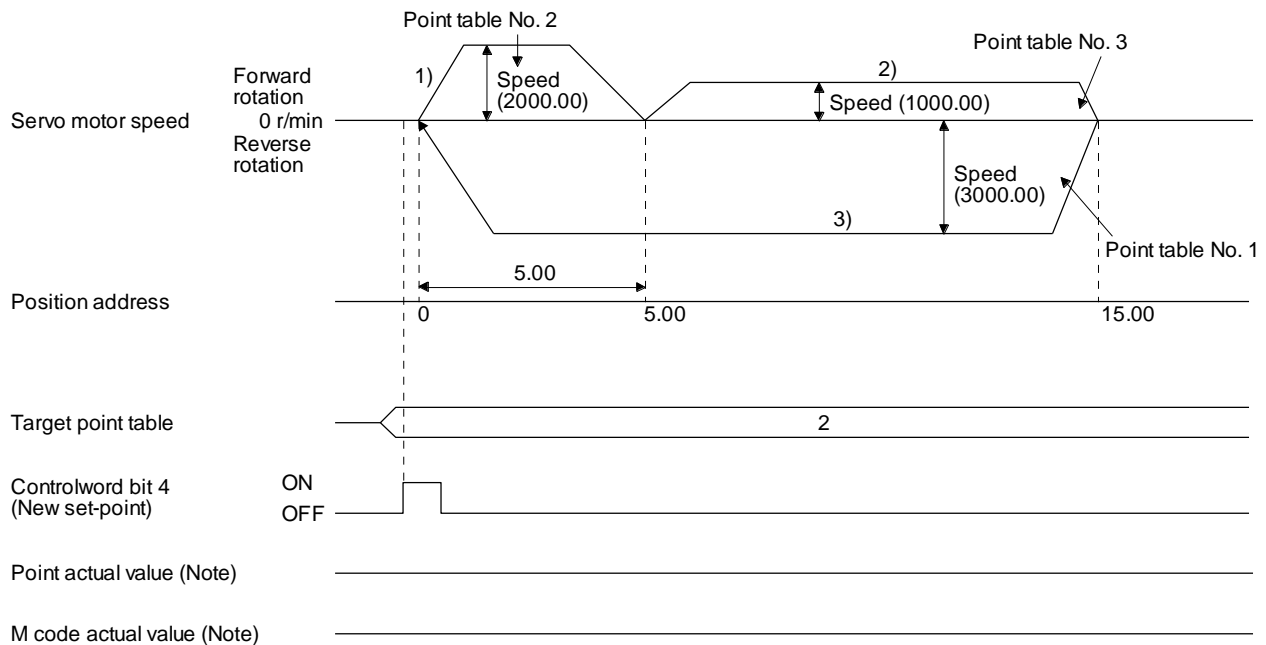

Note. "Point actual value" and "M code actual value" are not outputted in an automatic continuous operation.

16. HOW TO USE THE POINT TABLE

2) Automatic repeat positioning operation by relative position command method

Example 1. Operations when "10" is set to the auxiliary function of point table No. 4

Point table No.	Position data [10 ^{STM} μm]	Servo motor speed [r/min]	Acceleration time constant [ms]	Deceleration time constant [ms]	Dwell time [ms]	Auxiliary function	M code
1	4.00	1500.00	200	100	150	1	01
2	5.00	3000.00	100	150	100	3	05
3	10.00	2000.00	150	200	200	1	10
4	5.00	1000.00	300	100	150	10	15

Operation sequence

- 1) Starting with point table No. 2
- 2) Executing point table No. 3
- 3) Executing point table No. 4
- 4) Executing again point table No. 2 used at start-up when "10" is set to the auxiliary function of point table No. 4
- 5) Repeating the above execution in the sequence of 1) to 2) to 3) to 4) to 2) to 3) to 4)

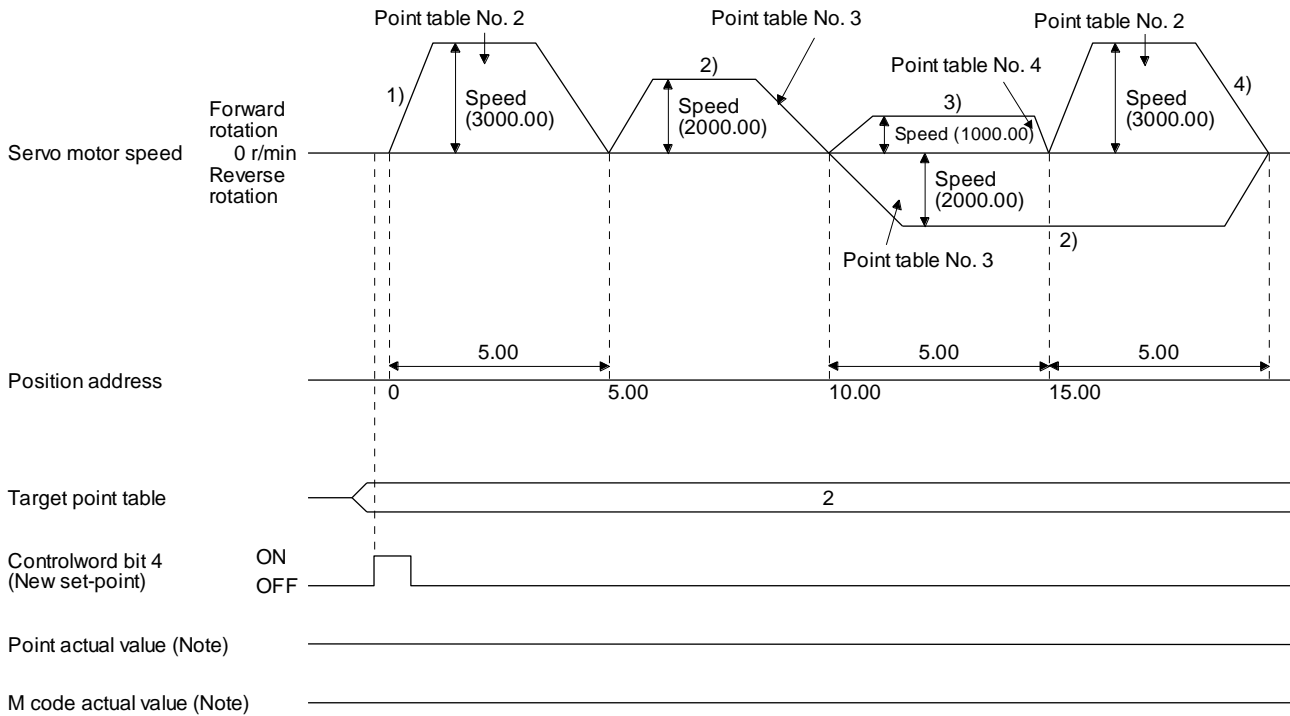

Note. "Point actual value" and "M code actual value" are not outputted in an automatic continuous operation.

16. HOW TO USE THE POINT TABLE

Example 2. Operations when "11" is set to the auxiliary function of point table No. 3

Point table No.	Position data [10 ^{STM} μm]	Servo motor speed [r/min]	Acceleration time constant [ms]	Deceleration time constant [ms]	Dwell time [ms]	Auxiliary function	M code
1	5.00	3000.00	100	150	100	3	05
2	10.00	2000.00	150	200	200	1	10
3	5.00	1000.00	300	100	150	11	15

Operation sequence

- 1) Starting with point table No. 2
- 2) Executing point table No. 3
- 3) Executing point table No. 1 when "11" is set to the auxiliary function of point table No. 3
- 4) Repeating the above execution in the sequence of 1) to 2) to 3) to 1) to 2) to 3)

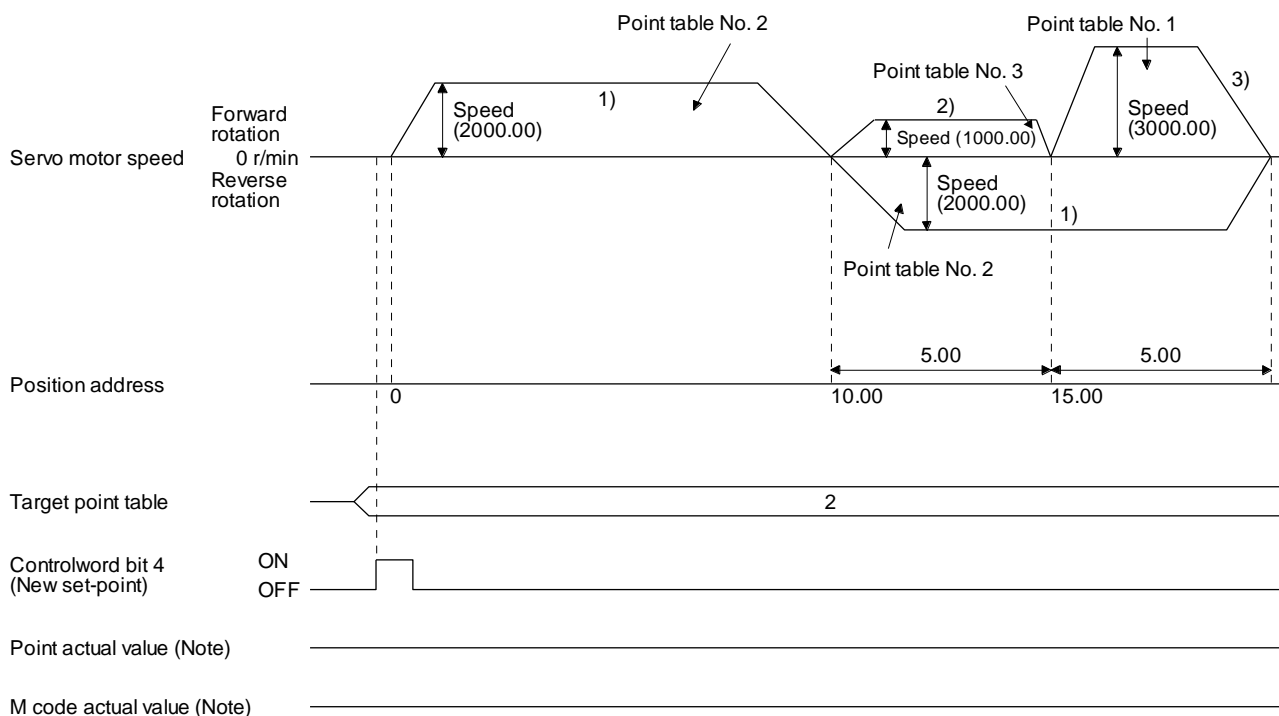

Note. "Point actual value" and "M code actual value" are not outputted in an automatic continuous operation.

16. HOW TO USE THE POINT TABLE

3) Varying-speed operation by absolute position command method

Example. Operations when "8" is set to the auxiliary function of point table No. 3

Point table No.	Position data [10 ⁵ TM μm]	Servo motor speed [r/min]	Acceleration time constant [ms]	Deceleration time constant [ms]	Dwell time [ms]	Auxiliary function	M code
1	5.00	3000.00	100	150	0	1	05
2	5.00	2000.00	Disabled	Disabled	0	3	10
3	15.00	1000.00	Disabled	Disabled	0	8	15

Operation sequence

- 1) Starting with point table No. 1
- 2) Varying the speed and executing point table No. 2
- 3) Varying the speed and executing point table No. 3
- 4) Executing point table No. 1 used at start-up in CW direction when "8" is set to the auxiliary function of point table No. 3
- 5) Repeating the above execution in the sequence of 1) to 2) to 3) to 4) to 2) to 3) to 4)

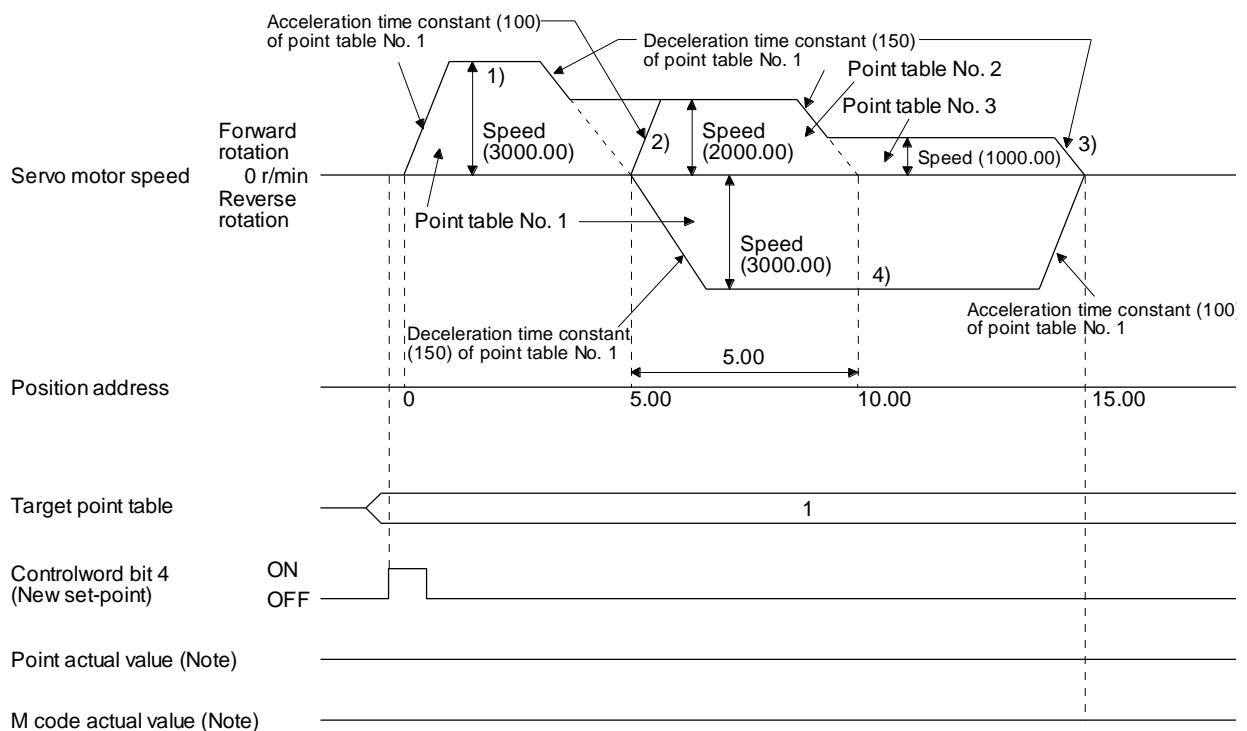

Note. "Point actual value" and "M code actual value" are not outputted in an automatic continuous operation.

16. HOW TO USE THE POINT TABLE

4) Varying-speed operation by relative value command method

Example. Operations when "10" is set to the auxiliary function of point table No. 3

Point table No.	Position data [10 ^{STM} μm]	Servo motor speed [r/min]	Acceleration time constant [ms]	Deceleration time constant [ms]	Dwell time [ms]	Auxiliary function	M code
1	5.00	3000.00	100	150	0	3	05
2	10.00	2000.00	150	200	0	1	10
3	5.00	1000.00	300	100	0	10	15

Operation sequence

- 1) Starting with point table No. 1
- 2) Varying the speed and executing point table No. 2
- 3) Varying the speed and executing point table No. 3
- 4) Varying the speed, and executing point table No. 1 when "10" is set to the auxiliary function of point table No. 3
- 5) Repeating the above execution in the sequence of 1) to 2) to 3) to 4) to 2) to 3) to 4)

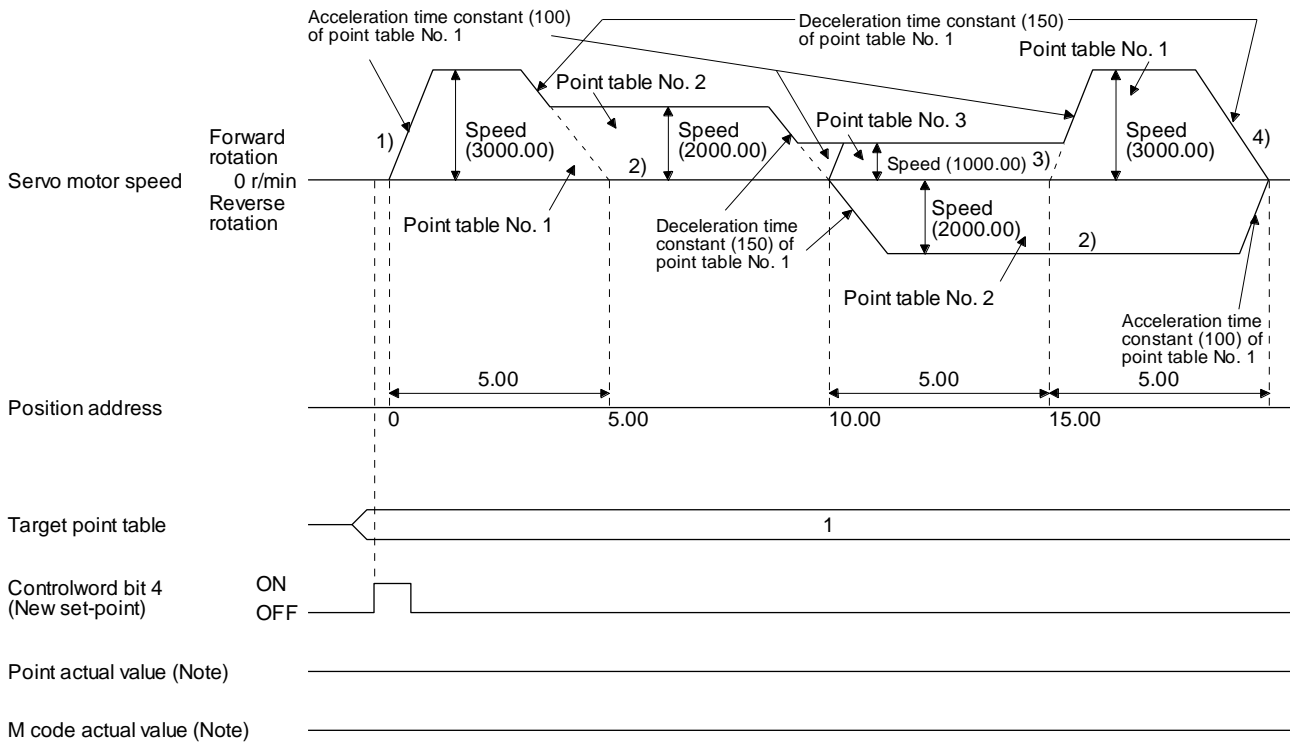

Note. "Point actual value" and "M code actual value" are not outputted in an automatic continuous operation.

16. HOW TO USE THE POINT TABLE

(e) Temporary stop/restart

When "Controlword bit 8 (HALT)" is switched on during automatic operation, the servo motor decelerates with the deceleration time constant of the point table being executed, and then stops temporarily. When "Controlword bit 8 (HALT)" is switched off during a temporary stop, the servo motor starts for the remaining travel distance.

"Controlword bit 4 (New set-point)" does not function even it is switched on during a temporary stop. When any of the following conditions is satisfied during a temporary stop, the travel remaining distance is cleared.

- The control mode is changed from the point table mode (pt) to the Jog mode (jg).
- The servo motor enters the servo-off status.

The temporary stop/restart input functions in the following status.

Operation status	Point table mode (pt)	Jog mode (jg)	Homing mode (hm)
During a stop		Temporary stop	Temporary stop
During acceleration	Temporary stop	Temporary stop	Temporary stop
At a constant speed	Temporary stop	Temporary stop	Temporary stop
During deceleration		Temporary stop	Temporary stop
During a temporary stop	Restart	Restart	Stop

1) When the servo motor is rotating

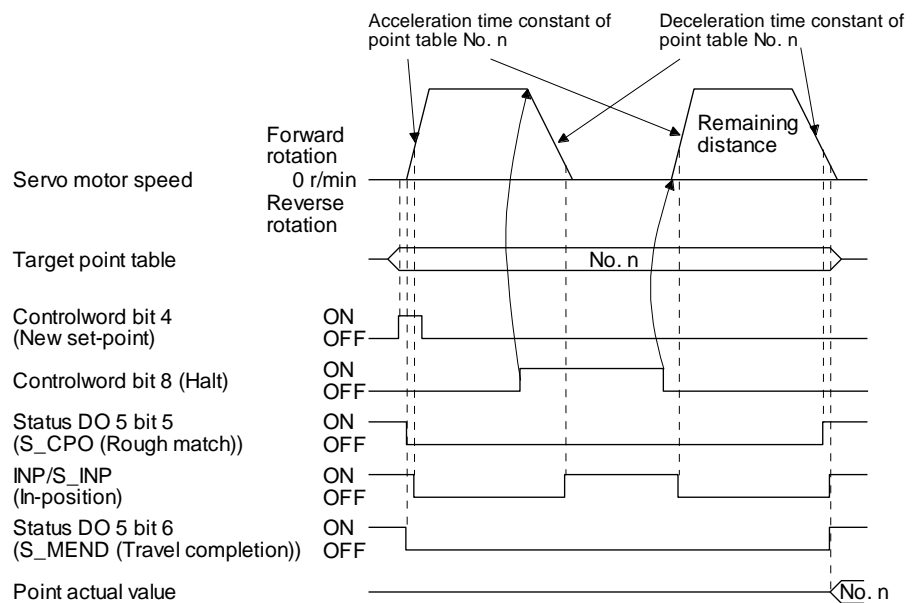

16. HOW TO USE THE POINT TABLE

2) During dwell

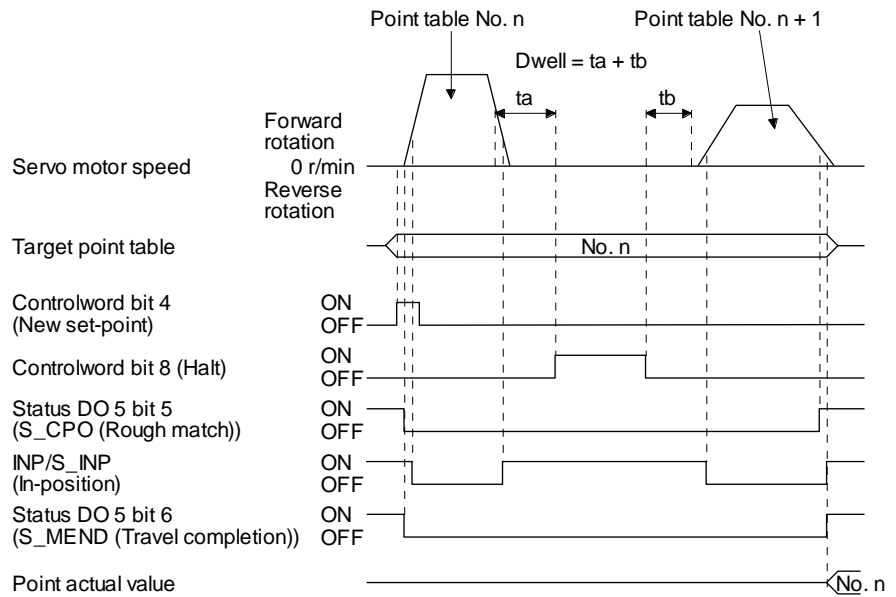

(f) Suspension of point table operation

To suspend the point table operation or change the operation pattern, stop the servo motor with "Controlword bit 8 (HALT)" and switch the control mode to Jog operation (jg) with "Modes of operation". The remaining travel distance is cleared.

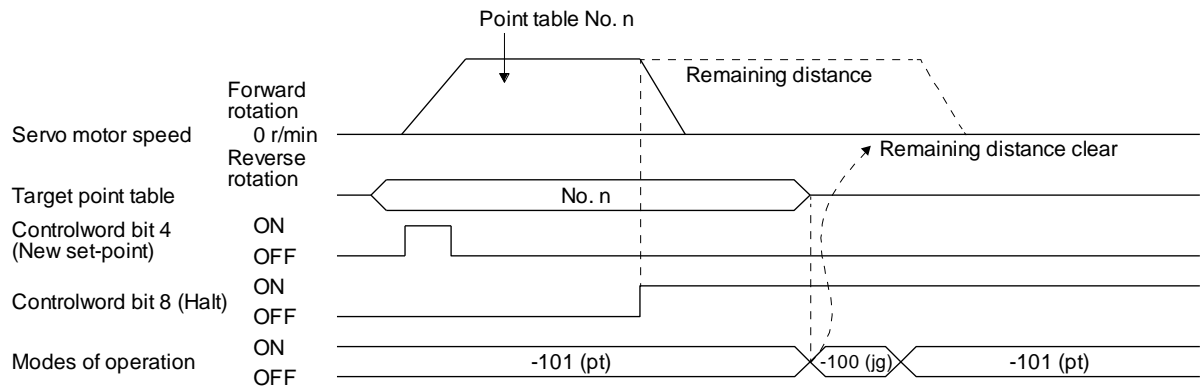

16. HOW TO USE THE POINT TABLE

16.4 Jog mode (jg)

For the machine adjustment, home position adjustment, and others, positioning to any point is possible with the JOG mode (jg).

(1) Setting

According to the purpose of use, set objects and parameters as shown below. In this case, "Target point table" is disabled.

Item	Object/parameter to be used	Setting
Jog mode (jg) selection	Modes of operation	Set "-100".
Servo motor rotation direction	[Pr. PA14]	Refer to (2) in this section.
JOG speed	Profile velocity	Set the servo motor speed.
Acceleration time constant	Profile Acceleration	Set the acceleration time constant.
Deceleration time constant	Profile deceleration	Set the deceleration time constant.
Speed limit	Max profile velocity	Set a speed limit value for during operation.

(2) Servo motor rotation direction

[Pr. PA14] setting	Servo motor rotation direction	
	Forward rotation start (Controlword bit 4 (Rotation start): on Controlword bit 5 (Direction): off)	Reverse rotation start (Controlword bit 4 (Rotation start): on Controlword bit 5 (Direction): on)
0	CCW rotation	CW rotation
1	CW rotation	CCW rotation

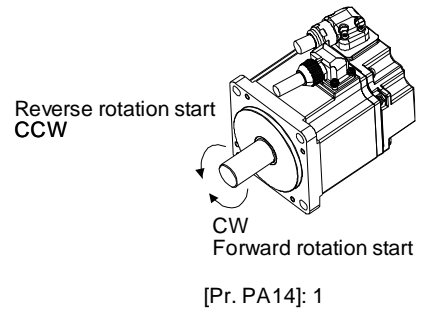
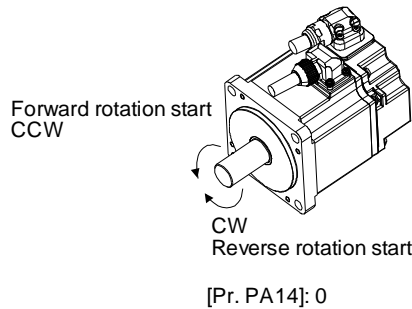

(3) Operation

Switching on "Controlword bit 4 (Rotation start)" starts at the set speed, acceleration time constant and deceleration time constant. Switching off "Controlword bit 4 (Rotation start)" makes a deceleration to a stop. Refer to (2) in this section for rotation direction.

Item	Object to be used	Setting
Start/stop	Controlword	Set start/stop in "Controlword bit 4 (Rotation start)". The setting is shown as follows: On: start Off: deceleration to a stop

16. HOW TO USE THE POINT TABLE

(4) Timing chart

(a) When operating at a constant speed

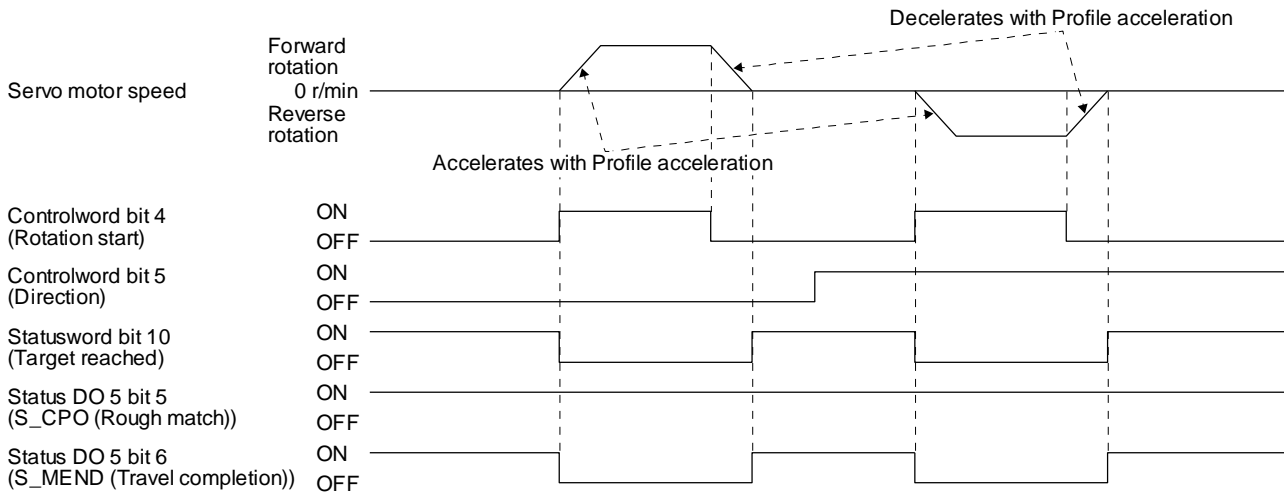

(b) When changing the speed during operation

You can change the servo motor speed by changing the "Profile velocity" during operation. However, the servo motor speed cannot be changed during deceleration. The acceleration time constant and the deceleration time constant can be changed only while the servo motor is stopped.

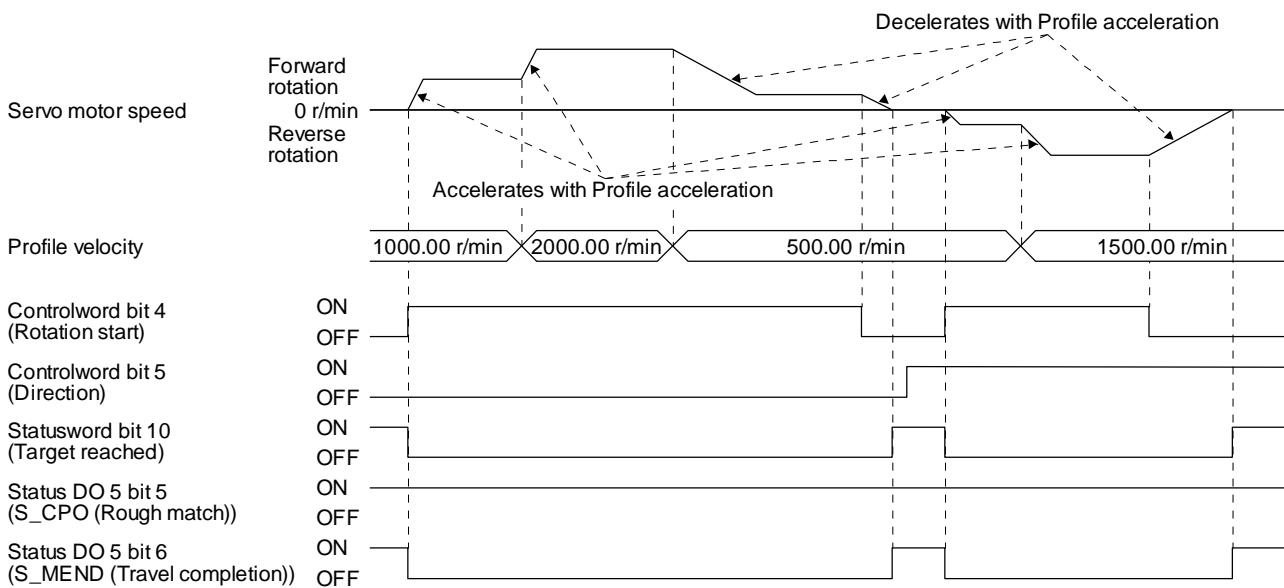

16. HOW TO USE THE POINT TABLE

16.5 Point table setting method

16.5.1 Point table setting method with Setup software (MR Configurator2™)

(1) Setting procedure

Click "Positioning-data" in the menu bar, and click "Point Table" in the menu.

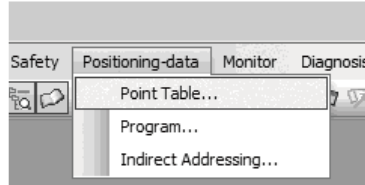

The following window will be displayed.

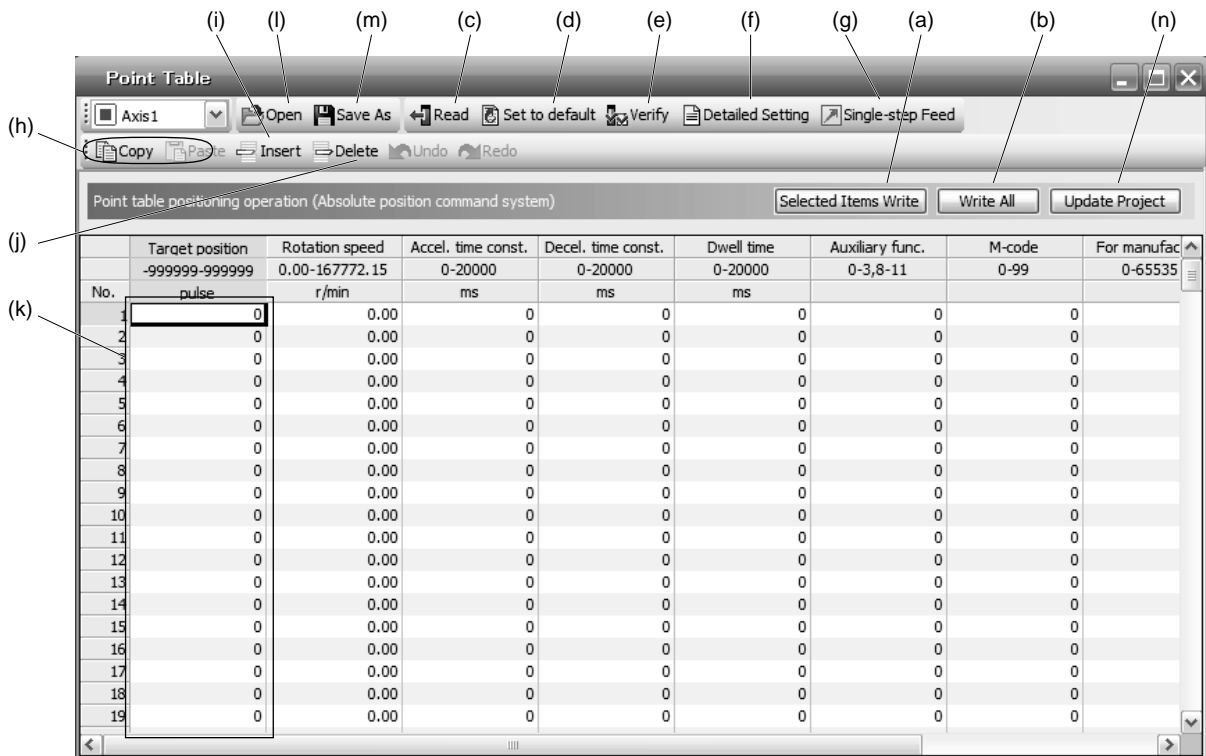

(a) Writing point table data (a)

Select changed point table data, and click "Selected Items Write" to write the changed point table data to the driver.

(b) Writing all point table data (b)

Click "Write All" to write all the point table data to the driver.

(c) Reading all point table data (c)

Click "Read" to read all the point table data from the driver and display them.

(d) Initial setting of point table data (d)

Click "Set to default" to initialize all the data of point table No. 1 to 255. This function also initializes data currently being edited.

16. HOW TO USE THE POINT TABLE

- (e) Verifying point table data (e)
Click "Verify" to verify all the data displayed and data of the driver.
- (f) Detailed setting of point table data (f)
Click "Detailed Setting" to change position data range and unit in the point table window. Refer to (2) in this section for details.
- (g) Single-step feed (g)
Click "Single-step Feed" to perform the single-step feed test operation. Refer to section 4.5.1 (1) (e) for details.
- (h) Copy and paste of point table data (h)
Click "Copy" to copy the selected point table data. Click "Paste" to paste the copied point table data.
- (i) Inserting point table data (i)
Click "Insert" to insert a block before the selected point table No. The selected block and later will be shifted down by one.
- (j) Deleting point table data (j)
Click "Delete" to delete the selected block of the point table No. The selected block and later will be shifted up by one.
- (k) Changing point table data (k)
After selecting the data to be changed, enter a new value, and click "Enter". You can change the displayed range and unit with (1) (f) "Detailed setting of point table data" in this section.
- (l) Reading point table data (l)
Click "Open" to read the point table data.
- (m) Saving point table data (m)
Click "Save As" to save the point table data.
- (n) Updating project (n)
Click "Update Project" to update the point table data to a project.

16. HOW TO USE THE POINT TABLE

(2) Detailed setting window

The position data range and unit can be changed with the detailed setting in the point table window. For the position data range and unit of [Pr. PT01] setting, refer to section 18.3.2. To reflect the setting for the corresponding parameter, click "Update Project" in the point table window.

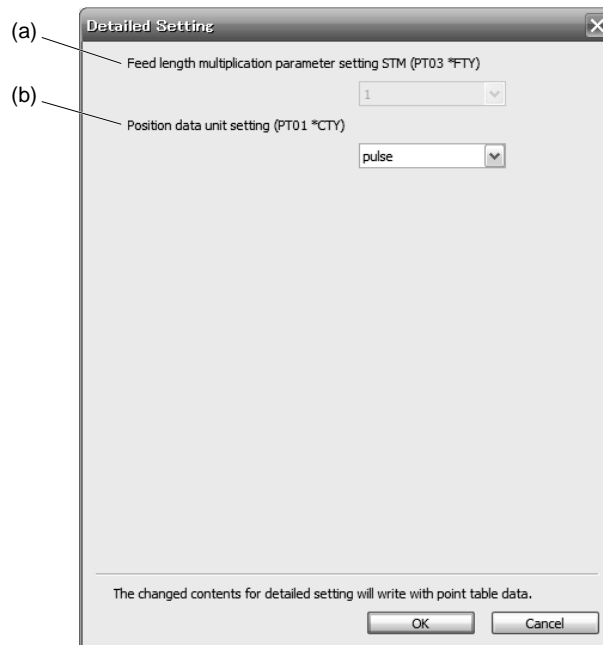

- (a) Feed length multiplication parameter setting STM (PT03 *FTY): 2
Select a feed length multiplication from 1/10/100/1000.
- (b) Position data unit setting (PT01 *CTY): 3
Select a unit of position data from mm/inch/pulse.

16. HOW TO USE THE POINT TABLE

16.5.2 Point table setting method with objects

(1) For EtherCAT

To change the point table of the driver on the master (upper side), write values to the following objects in the SDO communication. However, once the power supply is shut off, the changed setting is not held at the next startup. To hold the changed setting even after the power supply is shut-off, save the point table setting value to EEP-ROM using Store Parameters (1010h).

Index	Sub	Object	Name	Data Type	Access	Default	Description
2801h	0	ARRAY	Point table 001	U8	ro	7	Number of entries
	1		Point data	I32	rw		Set the position data of the point table No. 1.
	2		Speed	I32	rw		Set the servo motor speed of the point table No. 1.
	3		Acceleration	I32	rw		Set the acceleration time constant of the point table No. 1.
	4		Deceleration	I32	rw		Set the deceleration time constant of the point table No. 1.
	5		Dwell	I32	rw		Set the dwell time of the point table No. 1.
	6		Auxiliary	I32	rw		Set the auxiliary function of the point table No. 1.
	7		M code	I32	rw		Set the M code of the point table No. 1.
.
.
.
28FFh	0	ARRAY	Point table 255	U8	ro	7	Number of entries
	1		Point data	I32	rw		Set the position data of the point table No. 255.
	2		Speed	I32	rw		Set the servo motor speed of the point table No. 255.
	3		Acceleration	I32	rw		Set the acceleration time constant of the point table No. 255.
	4		Deceleration	I32	rw		Set the deceleration time constant of the point table No. 255.
	5		Dwell	I32	rw		Set the dwell time of the point table No. 255.
	6		Auxiliary	I32	rw		Set the auxiliary function of the point table No. 255.
	7		M code	I32	rw		Set the M code of the point table No. 255.

16. HOW TO USE THE POINT TABLE

(2) For PROFINET

To change the point table of the driver on the master (upper side), write values to the following objects in the Acyclic Data Exchange communication. However, once the power supply is shut off, the changed setting is not held at the next startup. To hold the changed setting even after the power supply is shut-off, save the point table setting value to EEPROM using Store Parameters (P4112).

PNU	Sub	Access	Name	Type	Default value	Description
10241	0	R/W	Point data	Array [7] Integer32		Set the position data of the point table No. 1.
	1		Speed			Set the servo motor speed of the point table No. 1.
	2		Acceleration			Set the acceleration time constant of the point table No. 1.
	3		Deceleration			Set the deceleration time constant of the point table No. 1.
	4		Dwell			Set the dwell time of the point table No. 1.
	5		Auxiliary			Set the auxiliary function of the point table No. 1.
	6		M code			Set the M code of the point table No. 1.
.
.
.
10495	0	R/W	Point data	Array [7] Integer32		Set the position data of the point table No. 255.
	1		Speed			Set the servo motor speed of the point table No. 255.
	2		Acceleration			Set the acceleration time constant of the point table No. 255.
	3		Deceleration			Set the deceleration time constant of the point table No. 255.
	4		Dwell			Set the dwell time of the point table No. 255.
	5		Auxiliary			Set the auxiliary function of the point table No. 255.
	6		M code			Set the M code of the point table No. 255.

17. HOW TO USE INDEXER

17 HOW TO USE INDEXER.....	2
17.1 Specification list	3
17.2 Switching power on for the first time.....	4
17.3 Indexer mode (idx).....	6
17.3.1 Indexer mode (idx)	6
17.3.2 Rotation direction specifying indexer	7
17.3.3 Shortest rotating indexer operation	11
17.4 Jog mode (jg)	14
17.4.1 Station JOG operation.....	14
17.4.2 JOG operation	16

17 HOW TO USE INDEXER

POINT	
	<ul style="list-style-type: none"> ● In the absolute position detection system, rotating the shaft one revolution or more during power-off may erase the home position. Therefore, do not rotate the shaft one revolution or more during power-off. When the home position is erased, [AL. 90 Home position return incomplete warning] will occur. Then, execute the home position return again. ● For the home position return, refer to chapter 18,19,20. ● There are the following restrictions on [Pr. PA06 Number of gear teeth on machine side] and the servo motor speed (N). <ul style="list-style-type: none"> ▪ When $CMX \leq 2000$, $N < 3076.7$ r/min ▪ When $CMX > 2000$, $N < (3276.7 - CMX)/10$ r/min <p>When the servo motor is operated at a servo motor speed higher than the limit value, [AL. E3 Absolute position counter warning] will occur.</p>

See the following table for the No. of each object mentioned in this chapter.

Object	No.	
	EtherCAT	PROFINET
Modes of operation	Index: 6060h	PNU: 24672, Sub: 0
Controlword	Index: 6040h	PNU: 24640, Sub: 0
Statusword	Index: 6041h	PNU: 24641, Sub: 0
Profile velocity	Index: 6081h	PNU: 24705, Sub: 0
Profile acceleration	Index: 6083h	PNU: 24707, Sub: 0
Profile deceleration	Index: 6084h	PNU: 24708, Sub: 0
Positive torque limit value	Index: 60E0h	PNU: 24800, Sub: 0
Negative torque limit value	Index: 60E1h	PNU: 24801, Sub: 0
Target point table	Index: 2D60h	PNU: 11616, Sub: 0
Status DO 1	Index: 2D11h	PNU: 11537, Sub: 0
Status DO 5	Index: 2D15h	PNU: 11541, Sub: 0
Point actual value	Index: 2D69h	PNU: 11625, Sub: 0
Torque limit value2	Index: 2D6Bh	PNU: 11627, Sub: 0

17. HOW TO USE INDEXER

17.1 Specification list

Item		Description	
Control mode	Indexer mode (idx)	Operational specifications	Positioning by specifying the station position The maximum number of divisions: 255
		Speed command input	Setting the servo motor speed, an acceleration time constant and deceleration time constant via network
		System	Rotation direction specifying indexer/shortest rotating indexer
		Torque limit	Limits the servo motor torque.
		Rotation direction specifying indexer	Positioning to the specified station. Rotation direction settable
		Shortest rotating indexer	Positioning to the specified station. Rotates in the shorter direction from the current position.
	Jog mode (jg)	JOG operation	Executes an inching operation via network. When the servo motor is stopping, deceleration to a stop is executed regardless of the station.
		Station JOG operation	Executes an inching operation via network. When the servo motor is stopping, positioning is executed to the nearest station at which the servo motor can decelerate to a stop.
	Homing mode (hm)	Torque limit changing dog type (front end detection Z-phase reference)	For the descriptions of the home position return types, refer to chapter 18,19,20
		Torque limit changing data set type	
		Homing on current position (method 35)	
		Homing on current position (method 37)	
	Other functions		Absolute position detection/external limit switch

17. HOW TO USE INDEXER

17.2 Switching power on for the first time

POINT
<ul style="list-style-type: none">●Set [Pr. PA01] to "___8" (positioning mode (indexer method)).●When using EtherCAT, set the mapping objects of 3rd RxPDO map (1602h) and 2nd TxPDO map (1A01h) in the PDO mapping. For details, refer to chapter 3.3.●When using PROFINET, set the communication format to Telegram 103. For details, refer to section 3.●In the indexer method, "Touch probe function" is disabled.●In the indexer method, "Position actual value", "Touch probe status", "Touch probe pos1 pos value", "Touch probe pos1 neg value", "Touch probe pos2 pos value" and "Touch probe pos2 neg value" will be always 0.

17. HOW TO USE INDEXER

When switching power on for the first time, follow this section to make a startup.

Startup procedure

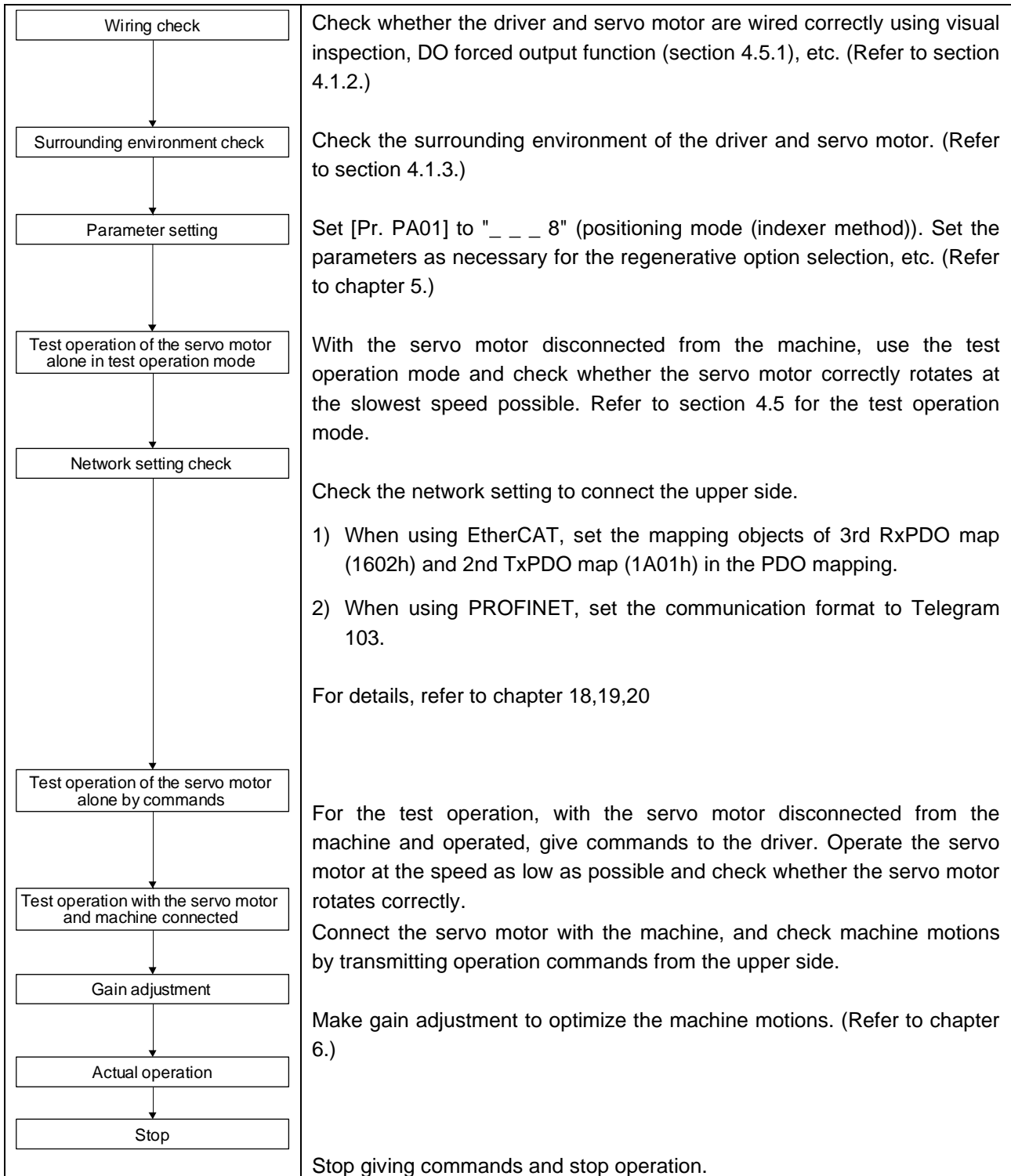

17. HOW TO USE INDEXER

17.3 Indexer mode (idx)

POINT
<ul style="list-style-type: none"> ● In the absolute position detection system, there are the following restrictions on [Pr. PA06 Number of gear teeth on machine side] and the servo motor speed (N). <ul style="list-style-type: none"> ▪ When $CMX \leq 2000$, $N < 3076.7 \text{ r/min}$ ▪ When $CMX > 2000$, $N < 3276.7 - CMX \text{ r/min}$ When the servo motor is operated at a servo motor speed higher than the limit value, [AL. E3 Absolute position counter warning] will occur. ● When the same next station No. is specified as station No. of the current position and a positioning operation is executed, the motor does not start because the travel distance is decided as "0".

17.3.1 Indexer mode (idx)

(1) Logic of indexer

The circumference of the load side (360 degrees) can be divided into a maximum of 255 stations. Positioning is executed to a station selected with "Target point table". The following diagram is an example for when [Pr. PA14] is set to "0".

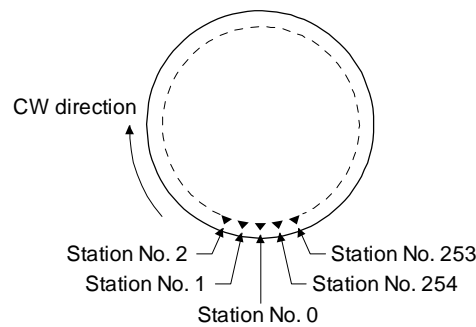

The station No. 0 is set as a home position. Set the number of stations with [Pr. PT28].

(2) Rotation direction

There are two operation methods: Rotation direction specifying indexer, which always rotates in a fixed direction and executes positioning to a station; Shortest rotating indexer, which automatically changes a rotation direction to the shortest distance and executes positioning to a station.

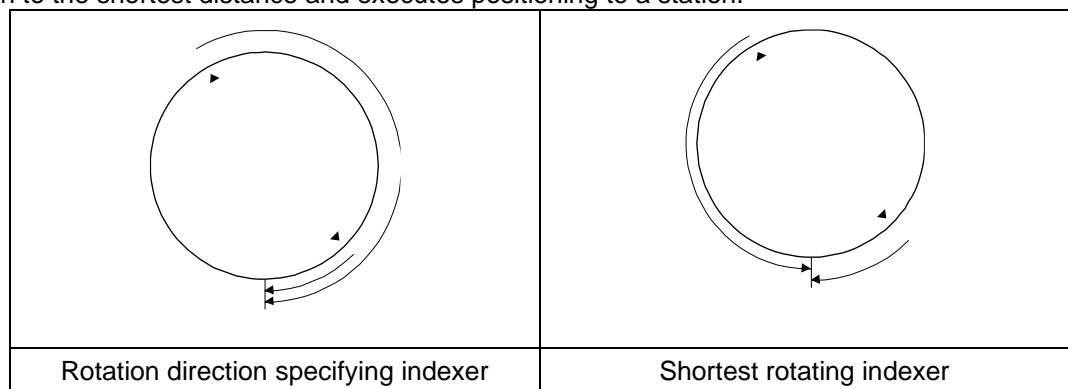

17. HOW TO USE INDEXER

17.3.2 Rotation direction specifying indexer

In this operation mode, the servo motor rotates in a fixed direction to execute positioning to a station. Select a station No. with "Target point table" to execute positioning. For the servo motor speed, acceleration time constant and deceleration time constant during operation, the values set in the object are used.

(1) Setting

Set objects and parameters as shown below.

Item	Object/parameter to be used	Setting
Indexer mode (idx) selection	Modes of operation	Set "-103".
Next station position	Target point table	Set any next station No.
Rotation direction specifying indexer selection	Controlword	Turn off "Controlword bit 6 (Operation mode)".
Servo motor speed	Profile velocity	Set the servo motor speed.
Acceleration time constant	Profile Acceleration	Set the acceleration time constant.
Deceleration time constant	Profile deceleration	Set the deceleration time constant.
Speed limit	Max profile velocity	Set a speed limit value for during operation.
Torque limit (Note)	Positive torque limit value Negative torque limit value	Set a torque limit value in operation.
	Torque limit value2	Set a torque limit value in stop.
	[Pr. PT39]	Set a time period for switching the torque limit value in operation to in stop.
No te.	The torque limit will change from the setting value of "Torque limit value2" to the setting value of "Positive torque limit value" or "Negative torque limit value" when "Controlword bit 4 (New set-point)" is inputted. After the output of S_MEND (Travel completion) and the time set with [Pr. PT39] has passed, the torque limit will be switched from the set value of "Positive torque limit value" or "Negative torque limit value" to the set value of "Torque limit value2".	

17. HOW TO USE INDEXER

(2) Other parameter settings

(a) Setting assignment direction of station No.

Select an assignment direction of station No. with [Pr. PA14].

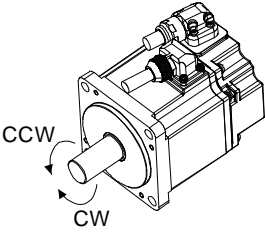
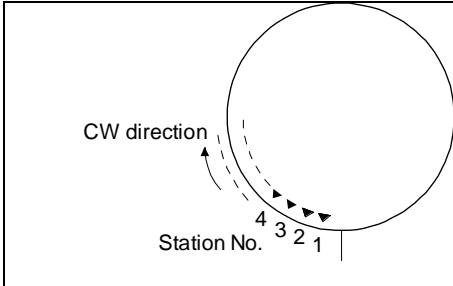
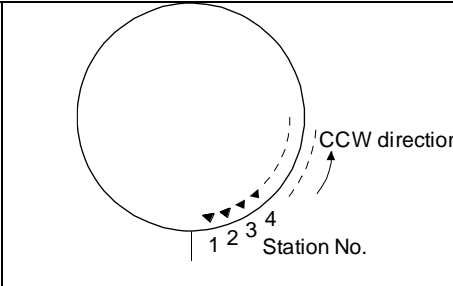
	[Pr. PA14] setting	Setting assignment direction of station No.
	0	Next station No. will be assigned in CW direction in order of 1, 2, 3...
	1	Next station No. will be assigned in CCW direction in order of 1, 2, 3...
		
	[Pr. PA14]: 0 (initial value)	[Pr. PA14]: 1

(b) Setting number of stations

Set a number of stations to [Pr. PT28].

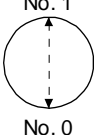
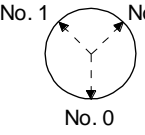
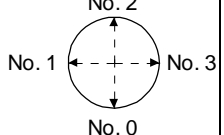
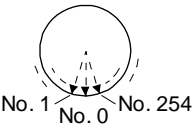
	[Pr. PT28] setting				
Number of stations	2	3	4	...	255
Station No.				...	

(3) Operation

Selecting the next station with "Target point table" and switching on "Controlword bit 4 (New set-point)" starts positioning to the selected next station at the set speed, acceleration time constant and deceleration time constant.

Item	Object to be used	Setting
Rotation direction selection	Controlword	Set the rotation direction in "Controlword bit 5 (Direction)". The setting is shown as follows: Off: Station No. decreasing direction On: Station No. increasing direction
Station No. selection	Target point table	Set a station No. at which positioning starts.
Start	Controlword	Switch on "Controlword bit 4 (New set-point)".

17. HOW TO USE INDEXER

(4) Timing chart

POINT

- Be sure to perform a home position return. Executing positioning operation without home position return will trigger [AL. 90 Home position return incomplete warning] and "Controlword bit 4 (New set-point)" will be disabled.
- When a value of a next station position exceeds the value set in [Pr. PT28 Number of stations per rotation], "Controlword bit 4 (New set-point)" will be disabled.

The following timing chart shows that an operation is performed at a stop of the station No. 0 when servo-on.

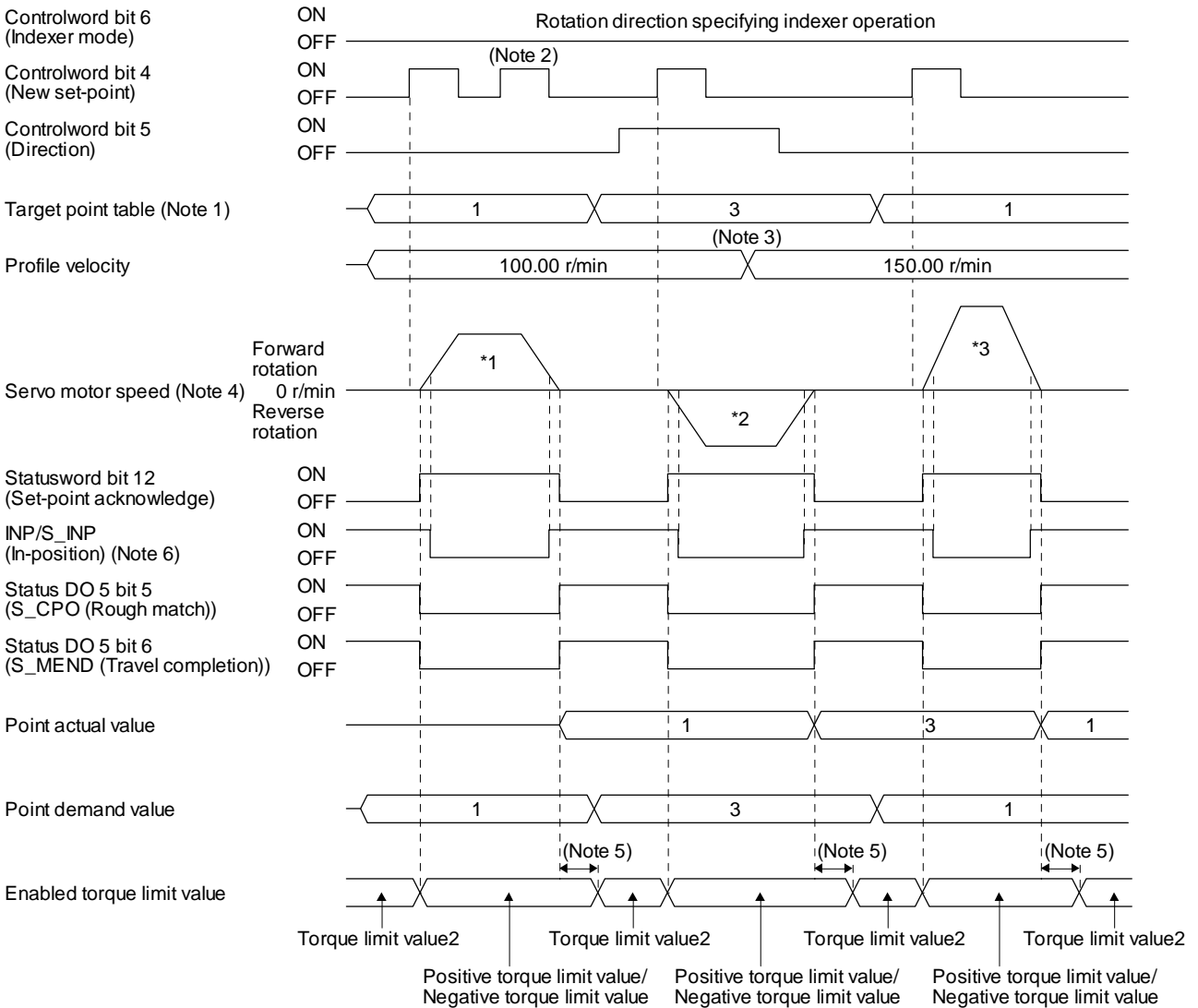

17. HOW TO USE INDEXER

- Note
1. When the specified station No. exceeds the value set in [Pr. PT28 Number of stations per rotation] -1, the servo motor does not operate.
 2. "Controlword bit 4 (New set-point)" is not received when the rest of command travel distance is other than "0".
 3. Switching "Profile velocity" during the servo motor rotation does not enable this.
 4. The following shows the operations to be executed.

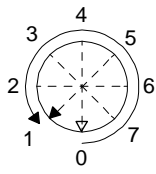
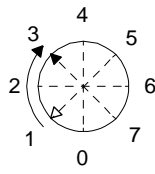
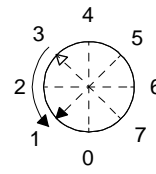
Operation	*1	*2	*3
Next station No.	No. 1	No. 3	No. 1
Servo motor speed	100.00 r/min	100.00 r/min	150.00 r/min
Positioning			

5. A delay time can be set with [Pr. PT39].
6. After power-on, this turns on if the value is within the in-position range of the corresponding station position.

17. HOW TO USE INDEXER

17.3.3 Shortest rotating indexer operation

This operation mode automatically changes a rotation direction to the shortest distance to execute positioning to a station.

Select a station No. with "Target point table" to execute positioning. For the servo motor speed, acceleration time constant and deceleration time constant during operation, the values set in the object are used.

(1) Setting

Set objects and parameters as shown below.

Item	Object/parameter to be used	Setting
Indexer mode (idx) selection	Modes of operation	Set "-103".
Next station position	Target point table	Set any next station No.
Shortest rotating indexer selection	Controlword	Switch on "Controlword bit 6 (Operation mode)".
Servo motor speed	Profile velocity	Set the servo motor speed.
Acceleration time constant	Profile Acceleration	Set the acceleration time constant.
Deceleration time constant	Profile deceleration	Set the deceleration time constant.
Speed limit	Max profile velocity	Set a speed limit value for during operation.
Torque limit (Note)	Positive torque limit value Negative torque limit value	Set a torque limit value for during operation.
	Torque limit value2	Set a torque limit value for during stop.
	[Pr. PT39]	Set a time period for switching the torque limit value in operation to in stop.
No te.	The torque limit will change from the setting value of "Torque limit value2" to the setting value of "Positive torque limit value" or "Negative torque limit value" when "Controlword bit 4 (New set-point)" is inputted. After the output of S_MEND (Travel completion) and the time set with [Pr. PT39] has passed, the torque limit will be switched from the set value of "Positive torque limit value" or "Negative torque limit value" to the set value of "Torque limit value2".	

(2) Other parameter settings

The setting is the same as in the rotation direction specifying indexer. Refer to section 19.3.2 (2).

(3) Operation

Selecting the next station with "Target point table" and switching on "Controlword bit 4 (New set-point)" starts positioning to the selected next station at the set speed, acceleration time constant and deceleration time constant.

Item	Object to be used	Setting
Station No. selection	Target point table	Set a station No. at which positioning starts.
Start	Controlword	Switch on "Controlword bit 4 (New set-point)".

17. HOW TO USE INDEXER

(4) Timing chart

POINT

- Be sure to perform a home position return. Executing positioning operation without home position return will trigger [AL. 90 Home position return incomplete warning] and "Controlword bit 4 (New set-point)" will be disabled.
- When travel distances to a target station position from CCW and from CW are the same, the shaft will rotate to the station No. increasing direction.

This disables "Controlword bit 5 (Direction)". The following timing chart shows that an operation is performed at a stop of the station No. 0 when servo-on.

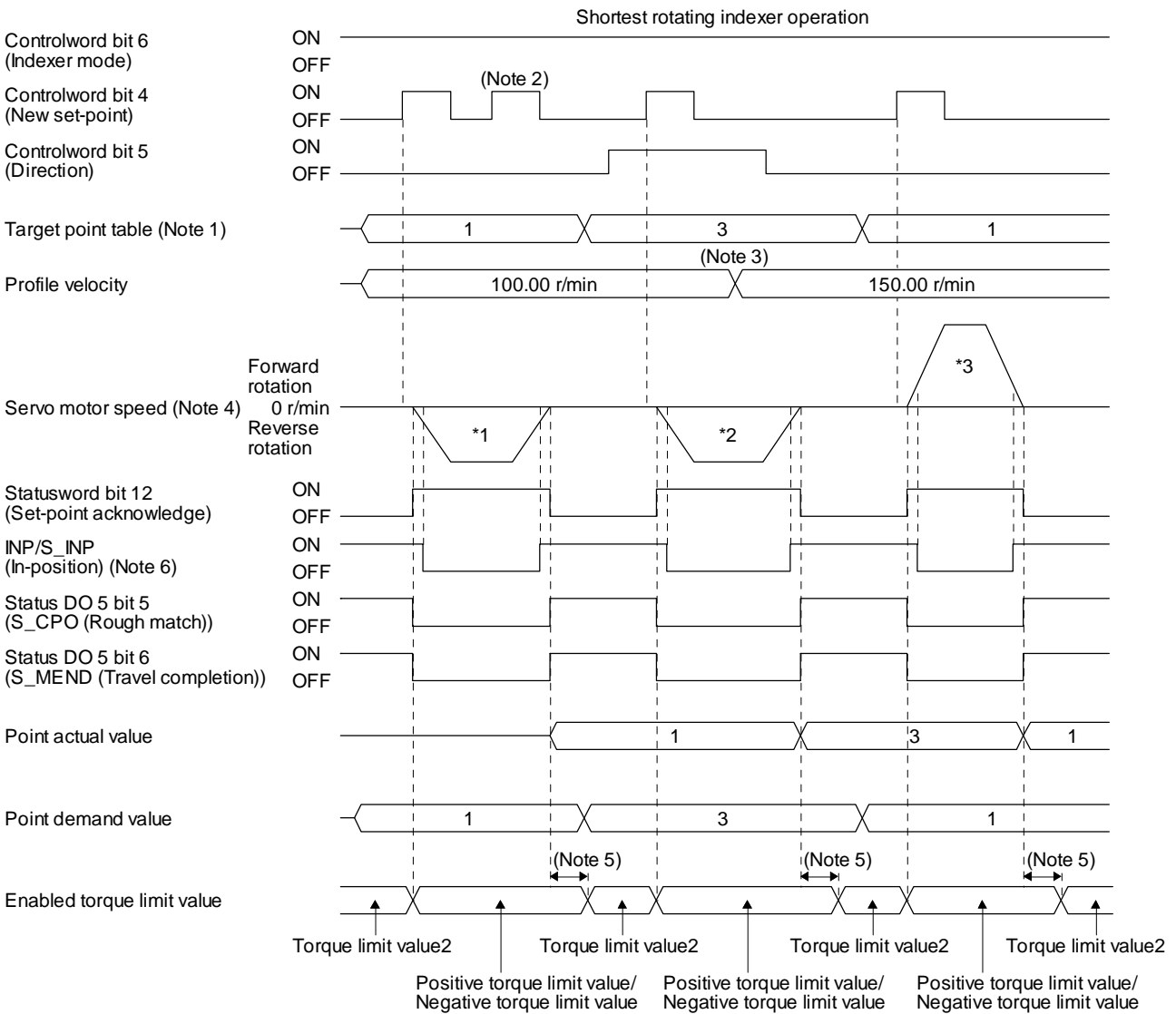

17. HOW TO USE INDEXER

- Note
1. When the specified station No. exceeds the value set in [Pr. PT28 Number of stations per rotation] -1, the servo motor does not operate.
 2. "Controlword bit 4 (New set-point)" is not received when the rest of command travel distance is other than "0".
 3. Switching "Profile velocity" during the servo motor rotation does not enable this.
 4. The following shows the operations to be executed.

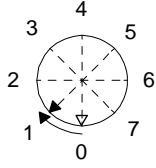
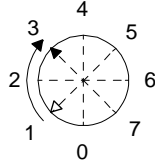
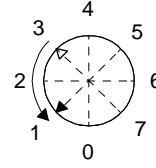
Operation	*1	*2	*3
Next station No.	No. 1	No. 3	No. 1
Servo motor speed	100.00 r/min	100.00 r/min	150.00 r/min
Positioning			

5. A delay time can be set with [Pr. PT39].
6. After power-on, this turns on if the value is within the in-position range of the corresponding station position.

17. HOW TO USE INDEXER

17.4 Jog mode (jg)

POINT
<p>● When the operation mode is changed during operation, inputting "Controlword bit 4 (Rotation start)" will be disabled. Switch on "Controlword bit 4 (Rotation start)" after the operation stops.</p>

For the machine adjustment, home position adjustment, and others, you can shift the position to any position with the station JOG operation and JOG operation.

17.4.1 Station JOG operation

(1) Setting

According to the purpose of use, set objects and parameters as shown below. In this case, "Target point table" is disabled.

Item	Object/parameter to be used	Setting
Jog mode (jg) selection	Modes of operation	Set "-100".
Station JOG operation selection	[Pr. PT27]	Select "__ 0 _" (Station JOG operation).
Servo motor speed	Profile velocity	Set the servo motor speed.
Acceleration time constant	Profile Acceleration	Set the acceleration time constant.
Deceleration time constant	Profile deceleration	Set the deceleration time constant.
Speed limit	Max profile velocity	Set a speed limit value for during operation.

(2) Setting assignment direction of station No.

Select an assignment direction of station No. with [Pr. PA14].

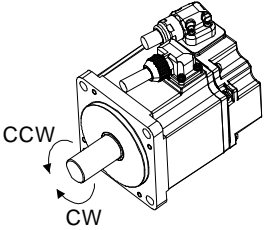
	[Pr. PA14] setting	Assignment direction of station No.
	0	Next station No. will be assigned in CW direction in order of 1, 2, 3...
	1	Next station No. will be assigned in CCW direction in order of 1, 2, 3...

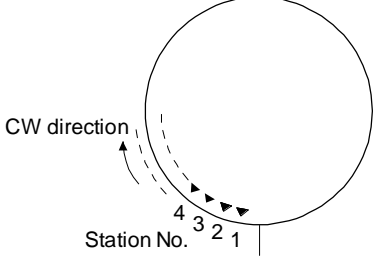
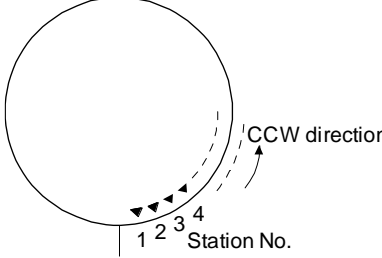
	
[Pr. PA14]: 0 (initial value)	[Pr. PA14]: 1

17. HOW TO USE INDEXER

(3) Operation

Turning on "Controlword bit 4 (Rotation start)" will start rotation to a direction specified with "Controlword bit 5 (Direction)", and turning off "Controlword bit 4 (Rotation start)" will execute a positioning to the closest station position which is possible to decelerate to a stop. However, the speed may not reach the specified speed because the shaft stops with the set time constant, depending on the setting value of deceleration time constant.

Item	Object to be used	Setting
Rotation direction selection	Controlword	Set the rotation direction in "Controlword bit 5 (Direction)". The setting is shown as follows: Off: Station No. decreasing direction On: Station No. increasing direction
Start/stop	Controlword	Set start/stop in "Controlword bit 4 (Rotation start)". The setting is shown as follows: On: start Off: stop at a station which is the closest and possible to decelerate to a stop

(4) Timing chart

The following timing chart shows that a JOG operation is performed at a stop of the station No. 0 when servo-on.

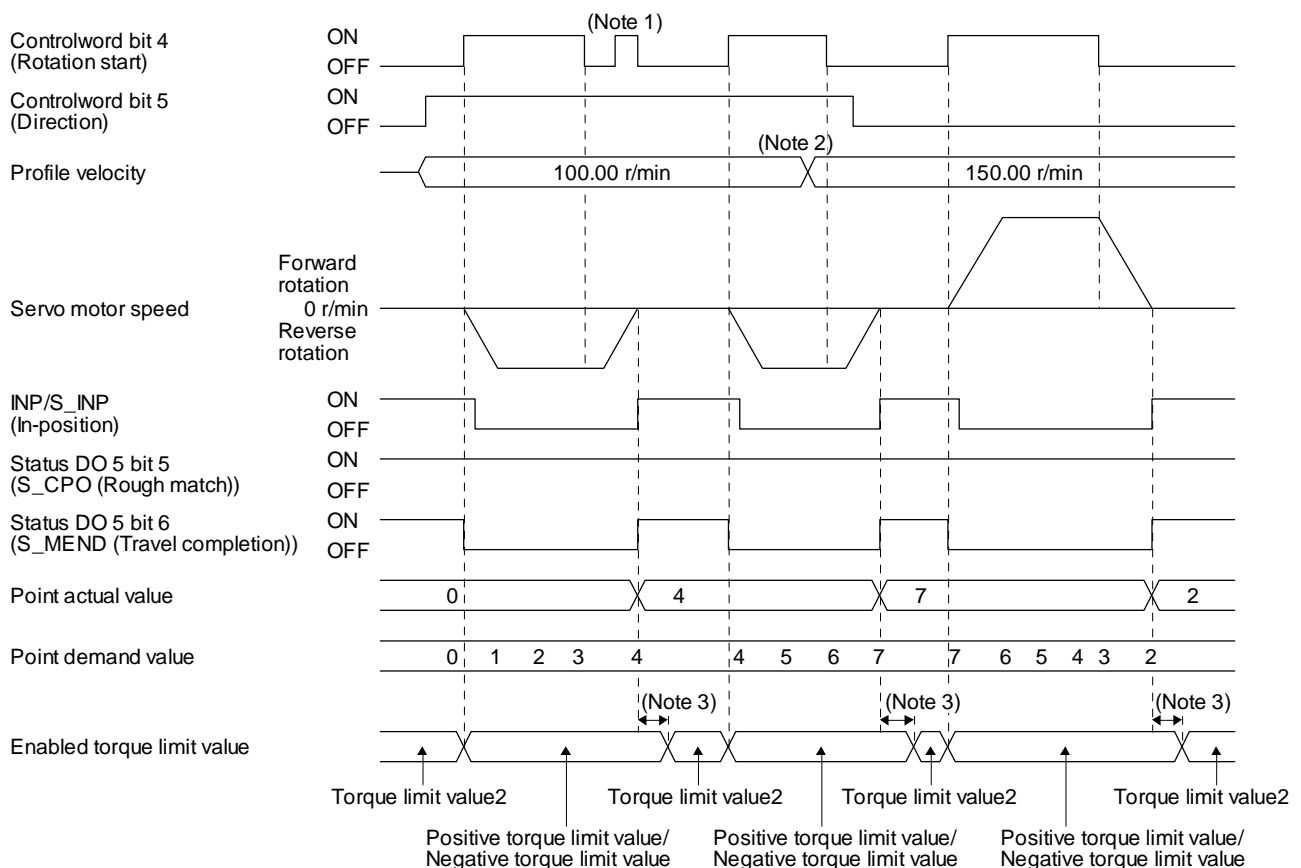

Note 1	"Controlword bit 4 (Rotation start)" is not received when the rest of command travel distance is other than "0".
Note 2	Switching "Profile velocity" during the servo motor rotation does not enable this.
Note 3	A delay time can be set with [Pr. PT39].

17. HOW TO USE INDEXER

17.4.2 JOG operation

(1) Setting

According to the purpose of use, set objects and parameters as shown below. In this case, "Target point table" is disabled.

Item	Object/parameter to be used	Setting
Jog mode (jg) selection	Modes of operation	Set "-100".
JOG operation selection	[Pr. PT27]	Select "_ _ 1 _" (JOG operation).
Servo motor speed	Profile velocity	Set the servo motor speed.
Acceleration time constant	Profile Acceleration	Set the acceleration time constant.
Deceleration time constant	Profile deceleration	Set the deceleration time constant.
Speed limit	Max profile velocity	Set a speed limit value for during operation.

(2) Operation

Turning on "Controlword bit 4 (Rotation start)" will start rotation to a direction specified with "Controlword bit 5 (Direction)", and turning off "Controlword bit 4 (Rotation start)" will make deceleration to a stop regardless of the station position.

Item	Object to be used	Setting
Rotation direction selection	Controlword	Set the rotation direction in "Controlword bit 5 (Direction)". The setting is shown as follows: Off: Station No. decreasing direction On: Station No. increasing direction
Start/stop	Controlword	Set start/stop in "Controlword bit 4 (Rotation start)". The setting is shown as follows: On: start Off: decelerate to a stop regardless of the station position

17. HOW TO USE INDEXER

(3) Timing chart

The following timing chart shows that a JOG operation is performed at a stop of the station No. 0 when servo-on.

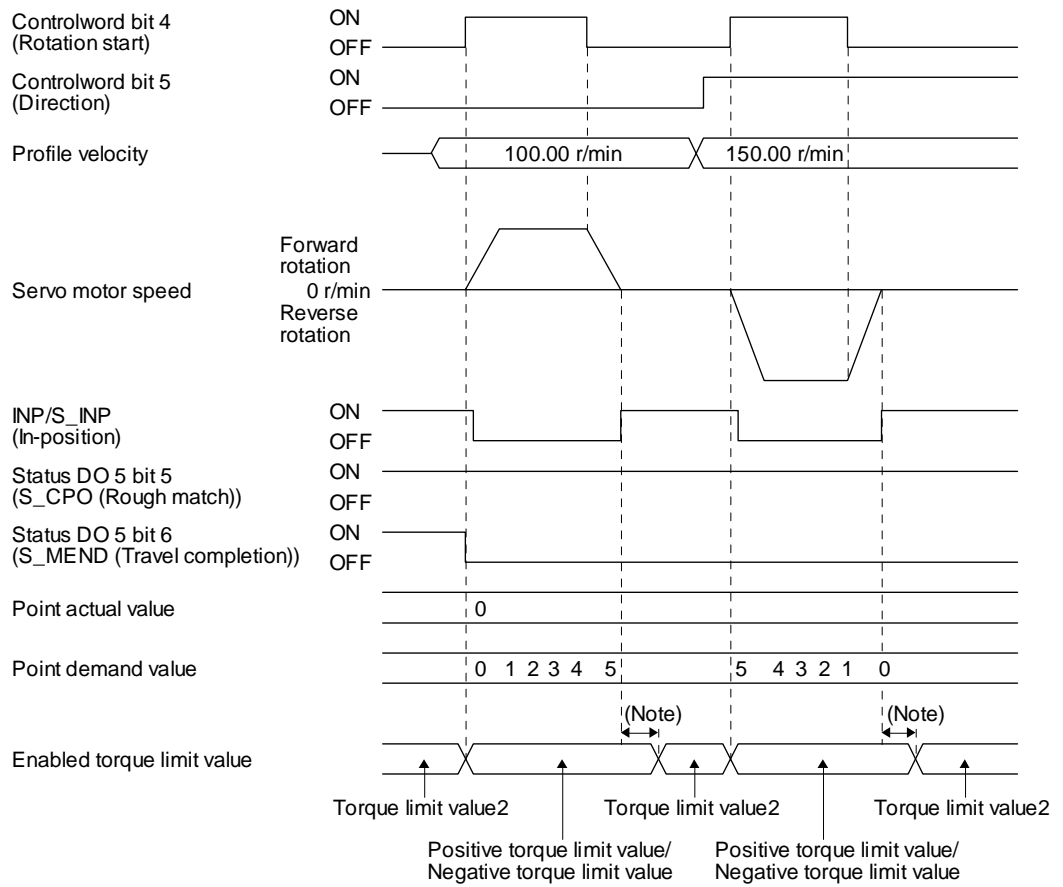

No	A delay time can be set with [Pr. PT39].
te.	

18. EtherCAT COMMUNICATION

18 EtherCAT COMMUNICATION.....	3
18.1 EtherCAT COMMUNICATION.....	3
18.1.1 Summary.....	3
18.1.2 Function list.....	6
18.1.3 Communication specifications.....	9
18.1.4 Communication specifications.....	10
18.1.4.1 Communication status.....	10
18.1.4.2 EtherCAT state.....	11
18.1.4.3 Startup.....	12
18.1.4.4 Network disconnection procedure.....	13
18.1.5 Summary of object dictionary (OD).....	14
18.1.5.1 Section definition of object dictionary.....	14
18.1.5.2 Saving object dictionary data to EEPROM.....	14
18.2 EtherCAT NETWORK CARD (LEC-S-NE).....	15
18.2.1 Specifications.....	15
18.2.2 Parts identification.....	16
18.2.3 LED indication.....	16
18.2.3.1 LED indication definition.....	16
18.2.3.2 LED indication list.....	17
18.2.4 Connecting Ethernet cable.....	18
18.3 PDO (PROCESS DATA OBJECT) COMMUNICATION.....	19
18.3.1 PDO communication cycle.....	19
18.3.2 PDO setting-related object.....	19
18.3.3 PDO default mapping.....	20
18.3.4 PDO variable mapping.....	22
18.3.5 Mapping-necessary objects.....	23
18.4 SDO (SERVICE DATA OBJECT) COMMUNICATION.....	25
18.4.1 SDO communication-related service.....	25
18.4.2 SDO Abort Code.....	26
18.5 CiA 402 DRIVE PROFILE.....	26
18.5.1 FSA state.....	26
18.5.2 Controlword/Control DI.....	29
18.5.2.1 Bit definition of Controlword.....	29
18.5.2.2 Bit definition of Control DI.....	30
18.5.3 Statusword/Status DO.....	32
18.5.3.1 Bit definition of Statusword.....	32
18.5.3.2 Bit definition of Status DO.....	33
18.5.4 Control mode.....	37
18.5.4.1 Selecting control mode (Modes of operation).....	37
18.5.4.2 Control switching.....	37
18.5.4.3 Cyclic synchronous position mode (csp).....	38
18.5.4.4 Cyclic synchronous velocity mode (csv).....	41
18.5.4.5 Cyclic synchronous torque mode (cst).....	43
18.5.4.6 Profile position mode (pp).....	45
18.5.4.7 Profile velocity mode (pv).....	49
18.5.4.8 Profile torque mode (tq).....	53
18.5.4.9 Homing mode (hm).....	56
18.5.4.10 Point table mode (pt).....	84
18.5.4.11 Jog mode (jg).....	89
18.5.4.12 Indexer mode (idx).....	96
18.5.5 Touch probe.....	103
18.5.6 Quick stop.....	107
18.5.7 Halt.....	108
18.5.8 Software position limit.....	109

18. EtherCAT COMMUNICATION

18. 5. 9	Torque limit	109
18. 5. 10	Polarity	110
18. 5. 11	Degree function	112
18. 5. 12	Torque offset.....	114
18. 6	MANUFACTURER FUNCTIONS	115
18. 6. 1	Object for status monitor	115
18. 6. 2	Incremental counter	117
18. 6. 3	Stroke end	117
18. 6. 4	Definition of alarm-related objects	118
18. 6. 5	Parameter object.....	119
18. 6. 5. 1	Definition of parameter objects	119
18. 6. 5. 2	Enabling parameters	120
18. 6. 7	One-touch tuning.....	121
18. 6. 8	Machine diagnosis function	123
18. 6. 9	Driver life diagnosis function.....	124
18. 7	OBJECT DICTIONARY	125
18. 7. 1	Store Parameters	125
18. 7. 2	Supported object dictionary list	126
18. 7. 3	Object dictionary.....	130
18. 7. 3. 1	General Objects	130
18. 7. 3. 2	PDO Mapping Objects	136
18. 7. 3. 3	Sync Manager Communication Objects.....	140
18. 7. 3. 4	Parameter Objects	145
18. 7. 3. 5	Alarm Objects.....	148
18. 7. 3. 6	Monitor Objects	151
18. 7. 3. 7	Manufacturer Specific Control Objects.....	164
18. 7. 3. 8	PDS Control Objects	175
18. 7. 3. 9	Position Control Function Objects	179
18. 7. 3. 10	Profile Velocity Mode Objects	182
18. 7. 3. 11	Profile Torque Mode Objects	184
18. 7. 3. 12	Profile Position Mode Objects.....	186
18. 7. 3. 13	Homing Mode Objects	190
18. 7. 3. 14	Factor Group Objects	196
18. 7. 3. 15	Touch Probe Function Objects.....	199
18. 7. 3. 16	Optional application FE Objects	200
18. 7. 3. 17	Point Table Mode Objects	203
18. 7. 3. 18	Cyclic synchronous position mode Objects	206

18 EtherCAT COMMUNICATION

18.1 EtherCAT COMMUNICATION

18.1.1 Summary

EtherCAT is the abbreviation of Ethernet for Control Automation Technology. It is open network communication between a master and slaves developed by Beckhoff Automation that uses real-time Ethernet. ETG (EtherCAT Technology Group) owns EtherCAT.

The EtherCAT communication is available when the EtherCAT network card (LEC-S-NE) is connected to the driver. The driver to which the EtherCAT network card is connected operates as a slave station compliant with CAN application protocol over EtherCAT (CoE) standards. The device type is a power drive system and is compatible with the CiA 402 drive profile.

Please download the configuration file (ESI file) from SMC website.
(Please use the data "LECSN.xml")

(1) CiA 402 drive profile compatible

The driver operates as a slave station compliant with CAN application protocol over EtherCAT (CoE) standards. The device type is a power drive system and is compatible with the CiA 402 drive profile.

(2) Various control modes supported

The _ driver supports the following control modes. In the table below, whether the synchronous mode and asynchronous mode can be used in each control mode. For the synchronous mode and asynchronous mode, refer to (3) in this section.

Control mode	Symbol	Description	Synchronous mode	Asynchronous mode	
Cyclic synchronous position mode	csp	This is a position mode where a position command is received at a constant period to drive the servo motor in the synchronous or asynchronous communication with a upper side. Use an absolute position address for a command.	Available	Available (Note 1, 2)	
Cyclic synchronous velocity mode	csv	This is a speed mode where a speed command is received at a constant period to drive the servo motor in the synchronous or asynchronous communication with a upper side.			
Cyclic synchronous torque mode	cst	This is a torque mode where a torque command is received at a constant period to drive the servo motor in the synchronous or asynchronous communication with a upper side.			
Profile position mode	pp	This is a positioning operation mode where an end position command is received to drive the servo motor in the synchronous or asynchronous communication with a upper side. Use an absolute position address or relative position address for a command.		Available	Available
Profile velocity mode	pv	This is a mode where a target speed command is received to drive the servo motor in the synchronous or asynchronous communication with a upper side.			
Profile torque mode	tq	This is a mode where a target torque command is received to drive the servo motor in the synchronous or asynchronous communication with a upper side.			
Homing mode	hm	This is a mode where the driver performs a home position return operation using the method directed by the upper side.			
Point table mode	pt	In this control mode, the servo motor is driven according to the travel distance and speed stored in the point table No. which is specified in the synchronous or asynchronous communication with a upper side. This control mode is not in CiA 402 standard.			
JOG mode	jg	In this control mode, the servo motor is manually driven at a speed set in the synchronous or asynchronous communication with a upper side. This control mode is not in CiA 402 standard			
Indexer mode	idx	In this control mode, the servo motor is driven to the station specified in the synchronous or asynchronous communication with a upper side. This control mode is not in CiA 402 standard			

- Note 1. Drivers cannot be used in the asynchronous mode. When the upper side sends an operation command in the asynchronous mode, the error code that indicates the state transition is not allowed is notified and the ERROR LED of the network card blinks.
2. Drivers can be used in the asynchronous mode. When it is used in the asynchronous mode, Cycle time (1C32h: 2) setting is required. For details on Cycle time (1C32h: 2), refer to (4) in this section.

18. EtherCAT COMMUNICATION

(3) Synchronous mode (DC mode)

In the synchronous mode, it is necessary to keep the synchronous jitter 2 μ s or less. When the synchronous jitter is 2 μ s or more, an error may be detected and an alarm may set off.

Synchronous mode setting		
	Sync0	Sync1
Cycle time (1C32h: 2)	0.25 ms (When the PDO communication cycle is set to 0.25 ms) 0.5 ms (When the PDO communication cycle is set to 0.5 ms) 1 ms (When the PDO communication cycle is set to 1 ms) 2 ms (When the PDO communication cycle is set to 2 ms)	Unused
Shift time (1C32h: 3)	0	

(4) Asynchronous mode (Free-run mode)

In the asynchronous mode, when using the cyclic synchronous position mode, the cyclic synchronous speed mode, and the cyclic synchronous torque mode, set as shown in the following table. Input the command value for each communication cycle set in Cycle time (1C32h: 2). If the command is not inputted on each communication cycle, the previously input command will be maintained.

Local Cycle time	
Cycle time (1C32h: 2) (Note)	0.25 ms (When the PDO communication cycle is set to 0.25 ms) 0.5 ms (When the PDO communication cycle is set to 0.5 ms) 1 ms (When the PDO communication cycle is set to 1 ms) 2 ms (When the PDO communication cycle is set to 2 ms)

Note.	If the value is not set for Cycle time, the PDO communication cycle is 0.25 ms (initial value).
-------	---

(5) Compliance with standards

_ drivers comply with the following standards. Refer to the following standards for the description not written in this Instruction Manual.

Standards	Version
ETG.1000.2 EtherCAT Specification – Part2 Physical Layer service definition and protocol specification	V1.0.3
ETG.1000.3 EtherCAT Specification – Part3 Data Link Layer service definition	V1.0.3
ETG.1000.4 EtherCAT Specification – Part4 Data Link Layer protocol specification	V1.0.3
ETG.1000.5 EtherCAT Specification – Part5 Application Layer service definition	V1.0.3
ETG.1000.6 EtherCAT Specification – Part6 Application Layer protocol specification	V1.0.3
ETG.1020 EtherCAT Protocol Enhancements	V1.1.0
ETG.1300 EtherCAT Indicator and Labeling Specification	V1.1.0
ETG.2000 EtherCAT Slave Information (ESI) Specification	V1.0.7
ETG.6010 Implementation Directive for CiA 402 Drive Profile	V1.1.0
IEC 61800-7-201 Adjustable speed electrical power drive systems – Part 7-201: Generic interface and use of profiles for power drive systems – Profile type 1 specification	Edition 1.0
Adjustable speed electrical power drive systems – Part 7-301: Generic interface and use of profiles for power drive systems – Mapping of profile type 1 to network technologies	Edition 1.0

18. EtherCAT COMMUNICATION

18.1.2 Function list

The following table lists the functions available with the driver to which the EtherCAT network card is connected. "-" means "-_ Driver Instruction Manual".

Function	Description	Reference
Cyclic synchronous position mode (csp)	The position control operation performed by a synchronous sequential position command through network is supported.	Section 5.4
Cyclic synchronous velocity mode (csv)	The speed control operation performed by a synchronous sequential speed command through network is supported.	
Cyclic synchronous torque mode (cst)	The torque control operation performed by a synchronous sequential torque command through network is supported.	
Profile position mode (pp)	The positioning operation performed by an asynchronous end position command through network is supported.	
Profile velocity mode (pv)	The speed control operation performed by an asynchronous speed command through network is supported.	
Profile torque mode (tq)	The torque control operation performed by an asynchronous torque command through network is supported.	
Homing mode (hm)	The home position return operation specified in each network is supported.	
Point table mode (pt)	Select any 1 to 255 point table and perform operation in accordance with the set values..	
Indexer mode (idx)	Perform operation to the station positions divided into 2 to 255..	
JOG mode (jg)	This is a control mode where the servo motor speed is set to drive the servo motor manually..	
Model adaptive control	This function achieves a high response and stable control following the ideal model. The two-degrees-of-freedom model adaptive control enables you to set a response to the command and a response to the disturbance separately. Additionally, this function can be disabled. To disable this function, refer to section 7.5 of "-_ Driver Instruction Manual".	
High-resolution encoder	High-resolution encoder of 4194304 pulses/rev is used for the encoder of the rotary servo motor compatible with the MELSERVO-J4 series.	
Absolute position detection system	Setting a home position once makes home position return unnecessary at every power-on.	- Chapter 12
Gain switching function	You can switch gains during rotation/stop, and can use input devices to switch gains during operation.	- Section 7.2
Advanced vibration suppression control II	This function suppresses vibration at an arm end or residual vibration.	- Section 7.1.5
Machine resonance suppression filter	This filter function (notch filter) decreases the gain of the specific frequency to suppress the resonance of the mechanical system.	- Section 7.1.1
Shaft resonance suppression filter	When a load is mounted to the servo motor shaft, resonance by shaft torsion during driving may generate a mechanical vibration of high frequency. The shaft resonance suppression filter suppresses the vibration.	- Section 7.1.3
Adaptive filter II	The driver detects mechanical resonance and sets filter characteristics automatically to suppress mechanical vibration.	- Section 7.1.2
Low-pass filter	Suppresses high-frequency resonance which occurs as the servo system response is increased.	- Section 7.1.4
Machine analyzer function	This function analyzes the frequency characteristic of the mechanical system by simply connecting an Setup software (MR Configurator2™)-installed personal computer and the driver. Setup software (MR Configurator2™) is necessary for this function.	
Robust filter	For roll feed axis, etc. of which a response level cannot be increased because of the large load to motor inertia ratio, this function improves a disturbance response.	[Pr. PE41]
Slight vibration suppression control	This function suppresses vibration of ±1 pulse generated at a servo motor stop.	[Pr. PB24]
Electronic gear	Positioning control is performed with the value obtained by multiplying the position command from the upper side by a set electronic gear ratio.	[Pr. PA06] [Pr. PA07]
S-pattern acceleration/ deceleration time constant	Speed can be increased and decreased smoothly.	[Pr. PT51]

18. EtherCAT COMMUNICATION

Function	Description	Reference
Auto tuning	Automatically adjusts the gain to optimum value if load applied to the servo motor shaft varies.	– Section 6.3
Power regeneration converter	Use the power regeneration converter when the regenerative option cannot provide sufficient regenerative capability. The power regeneration converter can be used for the drivers of the 5 kW or more.	– Section 11.4
Regenerative option	Use a regenerative option when the built-in regenerative resistor of the driver does not have sufficient regenerative capacity for a large regenerative power generated.	– Section 11.2
Alarm history clear	This function clears alarm histories.	[Pr. PC21]
Torque limit	Limits the servo motor torque.	[Pr. PA11] [Pr. PA12]
Speed limit	This function limits the servo motor speed.	[Pr. PT67]
Status display	Shows servo status on the 3-digit, 7-segment LED display	– Section 4.3
Input signal selection (device settings)	LSP (Forward rotation stroke end), LSN (Reverse rotation stroke end) and other input device can be assigned to any pins.	[Pr. PD03] to [Pr. PD05]
Output signal selection (device settings)	The output devices including ALM (Malfunction) can be assigned to specified pins of the CN3 connector.	[Pr. PD07] to [Pr. PD09]
Output signal (DO) forced output	Turns on/off the output signals forcibly independently of the servo status. Use this function for checking output signal wiring, etc.	– Section 4.5.1 (1) (d)
Test operation mode	Jog operation, positioning operation, motor-less operation, DO forced output, and program operation Setup software (MR Configurator2™) is necessary for this function.	– Section 4.5
Analog monitor output	This function outputs servo status with voltage in real time.	[Pr. PC09] [Pr. PC10]
Setup software (MR Configurator2™)	Using a personal computer, you can perform the parameter setting, test operation, monitoring, and others.	– Section 11.7
Latch function (Touch probe)	This function latches the current position at the rising edge of the external latch input signal.	Section 5.5 – Section 3.5 [Pr. PD37]
One-touch tuning	Gain adjustment is performed just by one click a certain button on Setup software (MR Configurator2™). Also, one-touch tuning can be performed via a network. One-touch tuning via a network is available with drivers .	Section 6.7 – Section 6.2
SEMI-F47 function	This function enables to avoid triggering [AL. 10 Undervoltage] using the electrical energy charged in the capacitor in case that an instantaneous power failure occurs during operation. Use a 3-phase for the input power supply of the driver. Using a 1-phase 100 V AC/200 V AC for the input power supply will not comply with SEMI-F47 standard.	– Section 7.4 [Pr. PA20] [Pr. PF25]
Tough drive function	This function makes the equipment continue operating even under the condition that an alarm occurs. The tough drive function includes two types: the vibration tough drive and the instantaneous power failure tough drive.	– Section 7.3

18. EtherCAT COMMUNICATION

Function	Description	Reference
Drive recorder function	This function continuously monitors the servo status and records the status transition before and after an alarm for a fixed period of time. You can check the recorded data on the drive recorder window on Setup software (MR Configurator2™) by clicking the "Graph" button. However, the drive recorder is not available when: 1. The graph function of Setup software (MR Configurator2™) is being used. 2. The machine analyzer function is being used. 3. [Pr. PF21] is set to "-1". 4. The upper side is not connected (except the test operation mode). 5. An alarm related to the upper side is occurring.	[Pr. PA23]
STO function	This driver complies with the STO function as functional safety of IEC/EN 61800-5-2. You can create a safety system for the equipment easily.	— Chapter 13
Driver life diagnosis function	You can check the cumulative energization time and the number of on/off times of the inrush relay. This function gives an indication of the replacement time for parts of the driver including a capacitor and a relay before they malfunction. This function is available with Setup software (MR Configurator2™) or via a network. The driver life diagnosis function via a network is available with drivers .	Section 6.9
Power monitoring function	This function calculates the power running energy and the regenerative power from the data in the driver such as speed and current. Power consumption and others are displayed on Setup software (MR Configurator2™). Also, the power monitoring function can be used via a network.	Section 6.1
Machine diagnosis function	From the data in the driver, this function estimates the friction and vibrational component of the drive system in the equipment and recognizes an error in the machine parts, including a ball screw and bearing. This function is available with Setup software (MR Configurator2™) or via a network. The machine diagnosis function via a network is available with drivers .	Section 6.8
Lost motion compensation function	This function improves the response delay occurred when the machine moving direction is reversed.	— Section 7.6
Super trace control	This function sets constant and uniform acceleration/deceleration droop pulses to almost 0.	— Section 7.7
Limit switch	Travel intervals can be limited with the limit switch using LSP (Forward rotation stroke end) and LSN (Reverse rotation stroke end)	
Software limit	Limits travel intervals by address using parameters. The same function with the limit switch is enabled by setting parameters.	Section 5.8 — Section 5.3 [Pr. PT15] to [Pr. PT18]
FoE (File Access over EtherCAT)	This driver supports FoE (File Access over EtherCAT). .	

18. EtherCAT COMMUNICATION

18.1.3 Communication specifications

The following table shows the communication specifications.

Item	Description	Remark
EtherCAT communication specifications	IEC 61158 Type121 CAN application protocol over EtherCAT (CoE), IEC 61800-7 CiA 402 Drive Profile	
Physical layer	100BASE-TX (IEEE802.3)	
Communication connector	RJ45, 2 ports (IN port, OUT port)	
Communication cable	CAT5e, shielded twisted pair (4 pair) straight cable	Double-shielded type recommended
Network topology	Line, Tree, Star, or a connection topology where the topologies are used together	
Variable communication speed	100 Mbps (Full duplex)	
Transmission speed between stations	Max. 100 m	
Number of nodes	Max. 65535	The number of connection nodes for actual use varies depending on the specifications of the master upper side used.
SDO (Mailbox) communication	Asynchronous Sending/Receiving: 1 channel each	Maximum data size in sending/receiving 1486 bytes each
PDO (Process Data) communication	Cycle time: Select from 0.25 ms, 0.5 ms, 1 ms, and 2 ms. Receive (RxPDO): 1 channel Send (TxPDO): 1 channel	Data size at PDO default mapping RxPDO: 29 bytes TxPDO: 41 bytes
PDO mapping	Variable PDO mapping supported	Maximum size of RxPDO and TxPDO: 64 bytes each Maximum number of object mapping: 32 each
Distributed clock (DC)	The DC mode and Free-run mode can be selected. (In drivers, the DC mode is required in the csp, csv, and cst mode.)	Sync0: Set the same cycle as the PDO communication cycle. Sync1: Not used
Explicit Device Identification	Supported	
LED display	RUN, ERROR, LINK/Activity (IN, OUT)	

18. EtherCAT COMMUNICATION

18.1.4 Communication specifications

The communication status of drivers is classified and managed by EtherCAT State Machine (ESM) that the EtherCAT standard specifies.

18.1.4.1 Communication status

The following table shows the classification of the communication status. Two communication types are provided: One is the PDO (process data object) communication where command data and feedback data are sent and received at a constant period. Another is the SDO (service data object) communication where object data is sent and received asynchronously. Refer to chapter 3 for details of the PDO communication. Refer to chapter 4 for details of the SDO communication.

ESM status	Description
Init	After the power is on, the communication status is the init state. The SDO communication and PDO communication cannot be performed. The master accesses the DL-Information register and initializes communication.
Pre-Operational	The SDO communication can be performed. The PDO communication cannot be performed. The initial setting for network and initial transfer of parameters can be performed in this state.
Safe-Operational	The SDO communication can be performed. Though the PDO communication also can be performed, all operations (commands) such as servo motor drive are invalid. When the DC mode is selected, synchronization is established in this state.
Operational	Both the SDO communication and PDO communication can be performed. Commands using the PDO communication are valid and the servo motor can be driven.
Bootstrap	The mailbox communication with the FoE protocol can be performed. Firmware can be updated through EtherCAT in this state. (For manufacturer setting)

18. EtherCAT COMMUNICATION

18.1.4.2 EtherCAT state

EtherCAT states shift under the conditions shown in figure 1.1 and table 1.1.

When the state shifts from the Init state through the Pre-Operational and Safe-Operational state to the Operational state, the driver can be operated. When the Operational state shifts to another state, the driver executes initialization to clear the internal status.

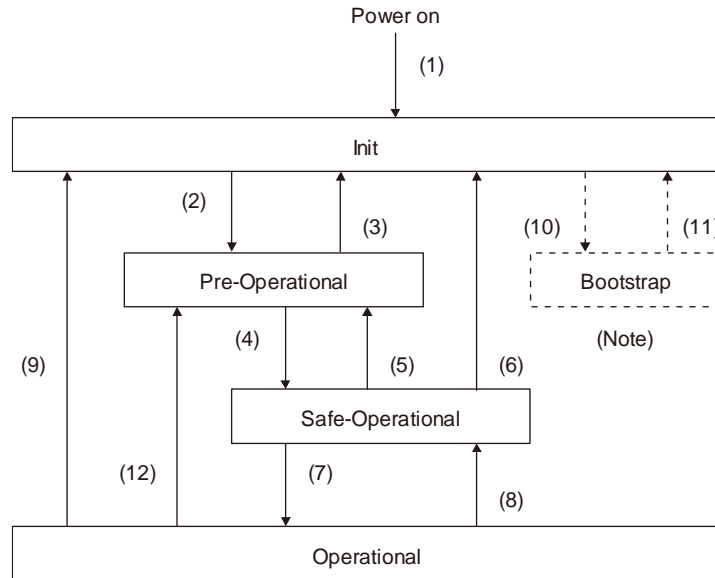

Note. This state is for manufacturer setting.

Fig. 1.1

Table. 1.1 EtherCAT state transition

Transition No.	Description
(1)	Power on
(2)	SDO communication configuration (a) The master sets the registers of the slaves. The following shows the registers to be set. • DL Address register • Sync Manager channel for SDO communication (b) The master requests the slaves to shift to the Pre-Operational state. (c) The state shifts to the Pre-Operational state.
(4)	PDO communication configuration (a) Set the configuration parameter of the master (such as PDO mapping) using the SDO communication. (b) The master sets the Sync Manager channel and FMMU channel for the PDO communication of the slaves. FMMU (Fieldbus Memory Management Unit) is a mechanism to manage the relationship between the global address area and the local address area in the EtherCAT communication. The global address area is used for the PDO communication. The local address area stores object data for each station. (c) The master requests the slave to shift to the Safe-Operational state. (d) The state shifts to the Safe-Operational state.
(7)	Synchronous (a) The master and slave use Distributed Clocks to synchronize. (b) The master starts to output a valid command value. (c) The master requests the slave to shift to the Operational state. (d) The state shifts to the Operational state.
(5), (12)	When the master requests the slave to shift to the Pre-Operational state, the state shifts to the Pre-Operational state.
(8)	When the master requests the slave to shift to the Safe-Operational state, the state shifts to the Safe-Operational state.
(3), (6), (9), (11)	In the following case, the state shifts to the init state. • When the master requests the slave to shift to the Init state.
(10)	When the master requests the slave to shift to the Bootstrap state, the state shifts to the Bootstrap state.

18. EtherCAT COMMUNICATION

18.1.4.3 Startup

The following describes the setting and startup of the EtherCAT communication. Refer to section 4.1 of "_ Driver Instruction Manual" for the startup procedure other than the network setting.

(1) Connection with the upper side

POINT
●Use the latest ESI file when setting up the upper side. If the ESI file is old, newly added objects may not be usable.

Set up the upper side following the manual of the upper side used. For the setup, the EtherCAT Slave Information (ESI) file listing the information about the communication setting of devices is available. Store the ESI file in the upper side to use it. The upper side configures the setting for the slave connected to the master according to the contents of the ESI file corresponding to the slave connected.

(2) Parameter setting

Set the control mode with [Pr. PA01 Operation mode]. Refer to section 5.2.1 of "_ Driver Instruction Manual" for the parameter setting.

(3) Node address setting

POINT
●The node address of _ drivers complies with the specifications of Explicit Device Identification. Configure the setting of Set Explicit Device Identification for the upper side.
●Do not connect multiple devices with the same node address setting.
●Node address setting via network and Configured Station Alias (0012h) are available with the combination of drivers and network cards .
●If the value in SII Configured Station Alias is set to other than 0000h when the node address is set with the axis selection rotary switch (SW2/SW3) or [Pr. PN01 Node address setting], the ERROR LED of the network card blinks. Cycling the power resets the set value in SII Configured Station Alias to 0000h and this enables the driver to start normally.

Set the node address of EtherCAT with the axis selection rotary switch (SW2/SW3) on the display, [Pr. PN01 Node address setting] or SII Configured Station Alias as necessary. You can set a node address as follows. After the node address setting is changed, cycle the power.

Axis selection rotary switch (SW2/SW3)	Pr. PN01	SII Configured Station Alias	Node address setting value
00h	0000h	0001h to FFFFh	The value set in SII Configured Station Alias via network is the node address.
00h	0001h to FFFFh	0000h (Note)	The value of [Pr. PN01] is set as the node address.
01h to FFh	0000h to FFFFh	0000h (Note)	The set value of the rotary switch (SW2/SW3) is set as the node address.

No te.	If the value in SII Configured Station Alias is set to other than 0000h, the ERROR LED of the network card blinks. Cycling the power resets the set value in SII Configured Station Alias to 0000h and this enables the driver to start normally.
--------	---

(4) Specifying the slave with the node address

The upper side can specify the slave with the node address in the following two methods.

(a) Specify with AL Status Code (0134h)

The value of the node address set in the axis selection rotary switch (SW2/SW3) or [Pr. PN01 Node address setting] can be read.

(b) Specify with Configured Station Alias (0012h)

The value of the node address set in the axis selection rotary switch (SW2/SW3), [Pr. PN01 Node address setting] or SII Configured Station Alias can be read.

18. 1. 4. 4 Network disconnection procedure

To disconnect the network by stopping device operation or other means, follow the procedure shown below. If the network is disconnected without following the procedure, [AL. 86.1 Network communication error 1] may occur.

- (1) Stop the servo motor.
- (2) Set the Shutdown command for Controlword (6040h) to establish the servo-off status.
- (3) Shift the state to the Pre-Operational state.
- (4) Shut off the power of the driver and upper side.

18. EtherCAT COMMUNICATION

18.1.5 Summary of object dictionary (OD)

POINT
●Refer to chapter 7 for details of the object dictionary.

Each data set that CAN application protocol over EtherCAT (CoE) devices have such as control parameters, command values, and feedback values is handled as an object composed of an Index value, object name, object type, R/W attribute, and other elements. The object data can be exchanged between the master and slave devices. The aggregate of these objects is called object dictionary (OD).

18.1.5.1 Section definition of object dictionary

In the CAN application protocol over EtherCAT (CoE) standard, objects of the object dictionary are categorized by Index depending on the area type as shown in the following table. Refer to the Reference column for the chapters and the section where the details of each object are described.

Index	Description	Reference
0000h to 0FFFh	Data type area	
1000h to 1FFFh	CoE communication area	Chapter 1, Chapter 3, Chapter 4, Chapter 7
2000h to 25FFh	Parameter area (Vendor-specific)	Section 6.5, Chapter 7
2800h to 29FFh	Point table area (Vendor-specific)	Chapter 7
2A00h to 2FFFh	Servo control command/monitor area (Vendor-specific)	Chapter 6, Chapter 7
6000h to 6FFFh	CiA 402 Drive profile area	Chapter 5, Chapter 7

18.1.5.2 Saving object dictionary data to EEPROM

There are two types of object dictionary data: One is saved to EEPROM and another is not saved. Refer to Section 7.3 for the availability and details of save for each object.

18. EtherCAT COMMUNICATION

18.2 EtherCAT NETWORK CARD (LEC-S-NE)

The EtherCAT communication with an driver requires the EtherCAT Network card (LEC-S-NE). The following shows the details.

18.2.1 Specifications

Item	Description
Product name	LEC-S-NE
Model	AB6916-C-203
Manufacturer	HMS Industrial Networks
External interface	driver connecting interface: Compact flash connector with standard 50 pins EtherCAT communication port interface: RJ45 connector
Dimensions	52 (W) × 50 (D) × 20 (H) (Except the protrusion of the EtherCAT communication port connector)
Mass	Approx. 30 g

18. EtherCAT COMMUNICATION

18.2.2 Parts identification

This section describes the EtherCAT Network card (LEC-S-NE) only. Refer to section 1.7 for the driver.

No.	Name/Application	Detailed explanation
(1)	ERROR LED Indicates an error of the EtherCAT communication.	Section 2.3.2 (2)
(2)	RJ45 EtherCAT communication port (OUT port) Used to connect the next axis driver.	Section 2.4
(3)	Link/Activity (OUT port) LED Indicates the link status of each EtherCAT communication port.	Section 2.3.2 (3)
(4)	RJ45 EtherCAT communication port (IN port) Used to connect the EtherCAT master upper side or the previous axis driver.	Section 2.4
(5)	Link/Activity (IN port) LED Indicates the link status of each EtherCAT communication port.	Section 2.3.2 (3)
(6)	RUN LED Indicates the EtherCAT communication status (ESM).	Section 2.3.2 (1)

18.2.3 LED indication

The LEDs of the EtherCAT Network card (LEC-S-NE) function according to the regulations of the EtherCAT standard (ETG.1300 EtherCAT Indicator and Labeling Specification). Under certain condition, such as when a fatal error occurs, the EtherCAT Network card (LEC-S-NE) indicates its status by its own specifications.

18.2.3.1 LED indication definition

The following shows the LED indication definitions.

LED status	Definition
Lit	An LED remains lit.
Extinguished	An LED remains extinguished.
Flickering	An LED is switching between lit and extinguished at 10 Hz cycles (every 50 ms).
Blinking	An LED is switching between lit and extinguished at 2.5 Hz cycles (every 200 ms).
Single flash	An LED is lit for 200 ms and extinguished 1000 ms repeatedly.
Double flash	An LED is lit for 200 ms, extinguished for 200 ms, lit for 200 ms, and extinguished for 1000 ms repeatedly.

18. EtherCAT COMMUNICATION

18.2.3.2 LED indication list

(1) RUN LED

The RUN LED indicates the EtherCAT communication status (ESM status). The extinguished RUN LED may be affected by the LED status of the Link/Activity LEDs. Refer to section 1.4 for the communication status (ESM status).

LED		Description
Status	Color	
Extinguished	Green	Indicates that the power supply is shut off or the Init state.
Blinking		Indicates the Pre-Operational state.
Single flash		Indicates the Safe-Operational state.
Lit		Indicates the Operational state.
Lit	Red	Indicates that a fatal error has occurred. This indication is specific to the EtherCAT Network card (LEC-S-NE).

(2) ERROR LED

The ERROR LED indicates an error of the EtherCAT communication. If the driver indicates an alarm, follow the remedy of the alarm number.

LED		Description
Status	Color	
Extinguished	Red	No error
Blinking		Indicates that the EtherCAT state cannot be changed according to the master command.
Single flash		Indicates that the EtherCAT state has been changed autonomously due to an internal error.
Double flash		Indicates a watchdog error in the Sync manager.
Lit		Indicates the EXCEPTION state, which is an error state of the EtherCAT Network card (ABCC-M40-ECT).
Flickering		Indicates an error at start-up of the EtherCAT Network card (ABCC-M40-ECT).

(3) Link/Activity LED (OUT port/IN port)

The Link/Activity LEDs indicate the link status of each EtherCAT communication port.

LED		Description
Status	Color	
Extinguished	Green	Indicates that the power supply is shut off or the link-unestablished state.
Lit		Indicates that the link is established without traffic.
Flickering		Indicates that the link is established with traffic.

18. EtherCAT COMMUNICATION

18.2.4 Connecting Ethernet cable

POINT

- Use a twisted pair cable (double shielded) with Ethernet Category 5e (100BASE-TX) or higher as the Ethernet cable. The maximum cable length between nodes is 100 m.
- When connecting an Ethernet cable to an EtherCAT network port, ensure that the connection destination (OUT port (upper side) or IN port (lower side)) is correct.

To the RJ45 EtherCAT communication port (IN port), connect the Ethernet cable connected to the upper side or the previous axis driver. To the RJ45 EtherCAT communication port (OUT port), connect the Ethernet cable connected to the next axis driver. When the RJ45 EtherCAT communication port (OUT port) is not used, leave this port open.

When the node address is not used, an incorrect connection destination sets node addresses that do not correspond to the actual connection order and may cause a malfunction, such as an unintended axis operation.

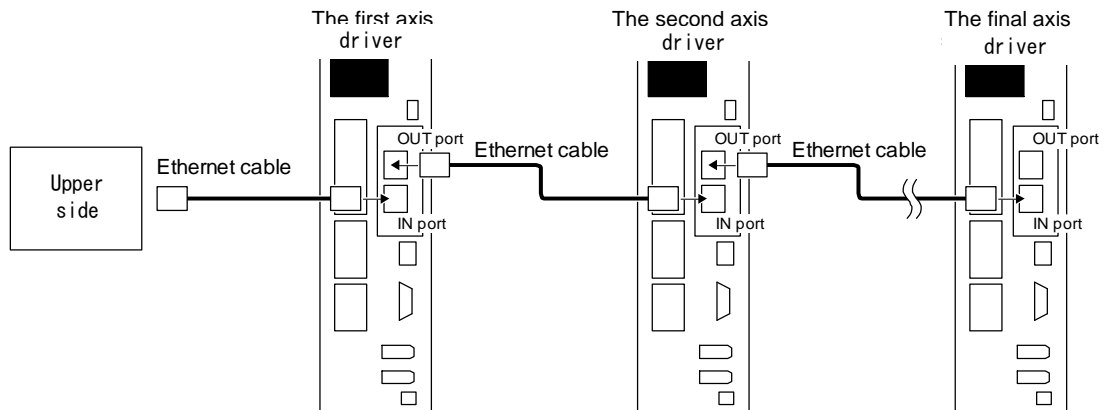

18. EtherCAT COMMUNICATION

18.3 PDO (PROCESS DATA OBJECT) COMMUNICATION

The PDO (process data object) communication can transfer command data and feedback data between a master (upper side) and slaves (driver) at a constant cycle. PDOs include RxPDOs, which are used by the slaves to receive data from the upper side, and TxPDOs, which are used by the slaves to send data to the upper side.

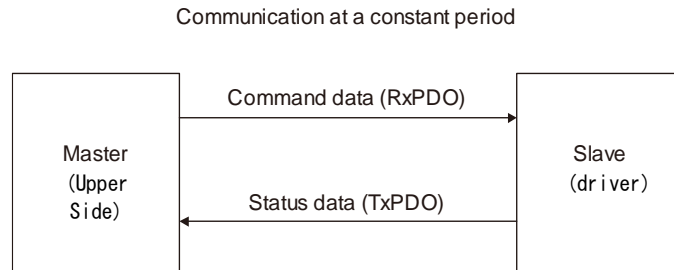

The variable PDO mapping function enables the PDO communication to transfer multiple PDOs in any array.

18.3.1 PDO communication cycle

The same cycle is applied to communication of RxPDOs and TxPDOs of the driver.

The communication cycle can be changed via a network through rewriting the sub object Cycle time (Sub index = 2) of SM output parameter (1C32h) with SDO download in the Pre Operational state.

18.3.2 PDO setting-related object

The following table lists the objects related to the PDO setting.

Index	Sub	Object	Name	Data Type	Access	Default	Description
1C32h	0	RECORD	SM output parameter	U8	ro	12	Refer to section 7.3.3 (4).
	1		Synchronization type	U16	rw	0	
	2		Cycle time	U32	rw	250000	
	3		Shift time	U32	rw (Note)	222222	
	4		Synchronization types supported	U16	ro	0025h	
	5		Minimum cycle time	U32	ro	250000	
	6		Calc and copy time	U32	ro	222722	
	9		Delay time	U32	ro	0	
	12		Cycle time too small	U16	ro	0	
1C33h	0	RECORD	SM input parameter	U8	ro	12	Refer to section 7.3.3 (5).
	1		Synchronization type	U16	rw	0	
	2		Cycle time	U32	ro	250000	
	3		Shift time	U32	rw (Note)	27778	
	4		Synchronization types supported	U16	ro	0025h	
	5		Minimum cycle time	U32	ro	250000	
	6		Calc and copy time	U32	ro	306055	
	9		Delay time	U32	ro	0	
	12		Cycle time too small	U16	ro	0	

Note. No value can be written because Shift time (1C32: 3, 1C33: 3) is set automatically. Writing any value causes SDO Abort Code (0609 0030h Value range of parameter exceeded).

18.3.3 PDO default mapping

POINT

●The driver supports the variable PDO mapping function, which can select objects transferred in the PDO communication. Refer to section 3.4 for changing the PDO mapping.

(1) RxPDO default mapping

In the default mapping setting, command data is sent from the master (upper side) to slaves (driver) with RxPDO in the following array. In the _ driver, the mapping objects of 1600h to 1603h can be used as the RxPDO default mapping table.

Map number	Mapping initial setting	Expected application of the initial map
1st RxPDO map (1600h)	Modes of operation (6060h) Controlword (6040h) Control DI 1 (2D01h) Control DI 2 (2D02h) Control DI 3 (2D03h) Target position (607Ah) Target velocity (60FFh) Velocity limit value (2D20h) (Note 1) Target torque (6071h) Positive torque limit value (60E0h) (Note 2) Negative torque limit value (60E1h) (Note 2) Touch probe function (60B8h)	Cyclic synchronous position mode (csp) Cyclic synchronous velocity mode (csv) Cyclic synchronous torque mode (cst) Homing mode (hm) Mapping for an application in which the modes above are switched The following functions can be used together. ▪ Speed limit function (in cst) ▪ Torque limit function ▪ Touch probe function Map size: 29 bytes
2nd RxPDO map (1601h)	Modes of operation (6060h) Controlword (6040h) Control DI 1 (2D01h) Control DI 2 (2D02h) Control DI 3 (2D03h) Target position (607Ah) Target velocity (60FFh) Velocity limit value (2D20h) (Note 1) Target torque (6071h) Profile velocity (6081h) Profile acceleration (6083h) Profile deceleration (6084h) Torque slope (6087h) Positive torque limit value (60E0h) (Note 2) Negative torque limit value (60E1h) (Note 2) Touch probe function (60B8h)	Profile position mode (pp) Profile velocity mode (pv) Profile torque mode (tq) Homing mode (hm) Mapping for an application in which the modes above are switched The following functions can be used together. ▪ Speed limit function (in tq) ▪ Torque limit function ▪ Touch probe function Map size: 45 bytes
3rd RxPDO map (1602h)	Modes of operation (6060h) Controlword (6040h) Control DI 1 (2D01h) Control DI 2 (2D02h) Control DI 3 (2D03h) Target point table (2D60h) Profile velocity (6081h) Profile acceleration (6083h) Profile deceleration (6084h) Touch probe function (60B8h)	Point table mode (pt) or indexer mode (idx) Jog mode (jg) Homing mode (hm) Mapping for an application in which the modes above are switched. Map size: 25 bytes
4th RxPDO map (1603h)	Unassigned	

- Note 1. The Velocity limit value (2D20h) is a speed limit value for the torque control. Be sure to set a correct value because setting 0 will limit the speed to 0.
- Note 2. Positive torque limit value (60E0h)/Negative torque limit value (60E1h) are torque limit values of forward/reverse rotation. Setting 0 will not generate torque. Be sure to set a correct value.

18. EtherCAT COMMUNICATION

(2) TxPDO default mapping

In the default mapping setting, status data of the _ driver is sent to the master (upper side) with TxPDO in the following array. In the _ driver, the mapping objects of 1A00h to 1A03h can be used as the TxPDO default mapping table.

Map number	Mapping initial setting	Expected application of the initial map
1st TxPDO map (1A00h)	Modes of operation display (6061h) Statusword (6041h) Status DO 1 (2D11h) Status DO 2 (2D12h) Status DO 3 (2D13h) Position actual value (6064h) Velocity actual value (606Ch) Following error actual value (60F4h) Torque actual value (6077h) Touch probe status (60B9h) Touch probe pos1 pos value (60BAh) Touch probe pos1 neg value (60BBh) Touch probe pos2 pos value (60BCh) Touch probe pos2 neg value (60BDh)	Cyclic synchronous position mode (csp) Cyclic synchronous velocity mode (csv) Cyclic synchronous torque mode (cst) Homing mode (hm) Mapping for an application in which the modes above are switched Mapping for an application in which the modes below are switched <ul style="list-style-type: none"> ▪ Profile position mode (pp) ▪ Profile velocity mode (pv) ▪ Profile torque mode (tq) ▪ Homing mode (hm) The latched position by the touch probe function can be monitored. Map size: 41 bytes
2nd TxPDO map (1A01h)	Modes of operation display (6061h) Statusword (6041h) Status DO 1 (2D11h) Status DO 2 (2D12h) Status DO 3 (2D13h) Status DO 5 (2D15h) Status DO 7 (2D17h) Position actual value (6064h) Velocity actual value (606Ch) Following error actual value (60F4h) Torque actual value (6077h) Point demand value (2D68h) (Note) Point actual value (2D69h) (Note) M code actual value (2D6Ah) (Note) Touch probe status (60B9h) Touch probe pos1 pos value (60BAh) Touch probe pos1 neg value (60BBh) Touch probe pos2 pos value (60BCh) Touch probe pos2 neg value (60BDh)	Point table mode (pt) or indexer mode (idx) Jog mode (jg) Homing mode (hm) Mapping for an application in which the modes above are switched. Map size: 54 bytes
3rd TxPDO map (1A02h)	Unassigned	
4th TxPDO map (1A03h)	Unassigned	

18. EtherCAT COMMUNICATION

18.3.4 PDO variable mapping

POINT
●The PDO mapping can be changed only in the Pre Operational state.

The driver supports the variable PDO mapping function, which can arrange objects in any array for the data transferred with RxPDO or TxPDO.

The following table shows the specifications of the PDO variable mapping.

Communication	Maximum number of objects	Maximum size [byte]	Number of mapping settings
RxPDO	32	64	4 (1600h to 1603h)
TxPDO			4 (1A00h to 1A03h)

The following table lists the PDO mapping objects.

Index	Sub	Object	Name	Data Type	Access	Default	Description
1600h	0	RECORD	Receive PDO Mapping	U8	rw	12	Refer to section 7.3.2 (1).
	1 to 32		Mapped Object 001 to Mapped Object 032	U32	rw	60600008h to 00000000h	
1601h	0	RECORD	Receive PDO Mapping	U8	rw	16	Refer to section 7.3.2 (2).
	1 to 32		Mapped Object 001 to Mapped Object 032	U32	rw	60600008h to 00000000h	
1602h	0	RECORD	Receive PDO Mapping	U8	rw	10	Refer to section 7.3.2 (3).
	1 to 32		Mapped Object 001 to Mapped Object 032	U32	rw	60600008h to 00000000h	
1603h	0	RECORD	Receive PDO Mapping	U8	rw	0	Refer to section 7.3.2 (4).
	1 to 32		Mapped Object 001 to Mapped Object 032	U32	rw		
1A00h	0	RECORD	Transmit PDO Mapping	U8	rw	14	Refer to section 7.3.2 (5).
	1 to 32		Mapped Object 001 to Mapped Object 032	U32	rw	60610008h to 00000000h	
1A01h	0	RECORD	Transmit PDO Mapping	U8	rw	19	Refer to section 7.3.2 (6).
	1 to 32		Mapped Object 001 to Mapped Object 032	U32	rw	60610008h to 00000000h	
1A02h	0	RECORD	Transmit PDO Mapping	U8	rw	0	Refer to section 7.3.2 (7).
	1 to 32		Mapped Object 001 to Mapped Object 032	U32	rw		
1A03h	0	RECORD	Transmit PDO Mapping	U8	rw	0	Refer to section 7.3.2 (8).
	1 to 32		Mapped Object 001 to Mapped Object 032	U32	rw		
1C12h	0	ARRAY	Sync Manager 2 PDO Assignment	U8	ro	1	Refer to section 7.3.3 (2).

18. EtherCAT COMMUNICATION

Index	Sub	Object	Name	Data Type	Access	Default	Description
	1		PDO Mapping object index of assigned RxPDO	U16	rw	1600h	
1C13h	0	ARRAY	Sync Manager 3 PDO Assignment	U8	ro	1	Refer to section 7.3.3 (3).
	1		PDO Mapping object index of assigned TxPDO	U16	rw	1A00h	

18.3.5 Mapping-necessary objects

The following table lists the objects which are required for each mode.

(1) RxPDO

Object name (Index)	Mode (Note 1)										Function (Note 1)
	csp	csv	cst	pp	pv	tq	pt	jg	hm	idx	Touch probe
Controlword (6040h)	⊙	⊙	⊙	⊙	⊙	⊙	⊙	⊙	⊙	⊙	
Control DI 1 (2D01h) Gain switching	○	○	-	○	○	-	○	○	-	○	
Control DI 2 (2D02h) Proportional control	○	-	-	○	-	-	○	○	○	○	
Control DI 3 (2D03h)	-	-	-	-	-	-	○	○	-	○	
Target position (607Ah)	⊙	-	-	⊙	-	-	-	-	-	-	
Target velocity (60FFh)	-	⊙	-	-	⊙	-	-	-	-	-	
Target torque (6071h)	-	-	⊙	-	-	⊙	-	-	-	-	
Profile velocity (6081h)	-	-	-	○	-	-	-	○	-	○	
Profile acceleration (6083h)	-	-	-	○	○	-	-	○	-	○	
Profile deceleration (6084h)	-	-	-	○	○	-	-	○	-	○	
Torque slope (6087h)	-	-	-	-	-	○	-	-	-	-	
Velocity limit value (2D20h)	-	-	○	-	-	○	-	-	-	-	
Positive torque limit value (60E0h)	○	○	○	○	○	○	○	○	○	○	
Negative torque limit value (60E1h)	○	○	○	○	○	○	○	○	○	○	
Touch probe function (60B8h)											⊙
Watch dog counter DL (2D23h)	○	○	○	-	-	-	-	-	-	-	-
Target point table (2D60h)	-	-	-	-	-	-	⊙	-	-	⊙	-

Note 1. ⊙: Mapping required

○: Mapping recommended

-: Mapping not required

18. EtherCAT COMMUNICATION

(2) TxPDO

Object name (Index)	Mode (Note 1)										Function (Note 1)
	csp	csv	cst	pp	pv	tq	pt	jg	hm	idx	Touch probe
Statusword (6041h)	⊙	⊙	⊙	⊙	⊙	⊙	⊙	⊙	⊙	⊙	
Status DO 1 (2D11h)	○	○	○	○	○	○	○	○	○	○	
Status DO 2 (2D12h)	○	○	○	○	○	○	○	○	○	○	
Status DO 3 (2D13h)	○	○	○	○	○	○	○	○	○	○	
Status DO 5 (2D15h)	-	-	-	-	-	-	○	○	-	○	-
Status DO 7 (2D17h)	-	-	-	-	-	-	○	○	-	-	-
Position actual value (6064h)	○	○	○	○	○	○	○	○	○	-	
Following error actual value (60F4h)	○	-	-	○	-	-	○	○	-	○	
Velocity actual value (606Ch)	○	○	○	○	○	○	○	○	○	○	
Torque actual value (6077h)	○	○	○	○	○	○	○	○	○	○	
Touch probe status (60B9h)											⊙
Touch probe pos1 pos value (60BAh)											○
Touch probe pos1 neg value (60BBh)											○
Touch probe pos2 pos value (60BCh)											○
Touch probe pos2 neg value (60BDh)											○
Watch dog counter UL (2D24h)	○	○	○	-	-	-	-	-	-	-	-
Point actual value (2D69h)	-	-	-	-	-	-	○	-	-	○	-
M code actual value (2D6Ah)	-	-	-	-	-	-	○	-	-	-	-
Point demand value (2D68h)	-	-	-	-	-	-	○	-	-	○	-

Note 1. ⊙: Mapping required

○: Mapping recommended

-: Mapping not required

18. EtherCAT COMMUNICATION

18.4 SDO (SERVICE DATA OBJECT) COMMUNICATION

The SDO (service data object) communication can transfer object data between a master (upper side) and slaves (driver) asynchronously.

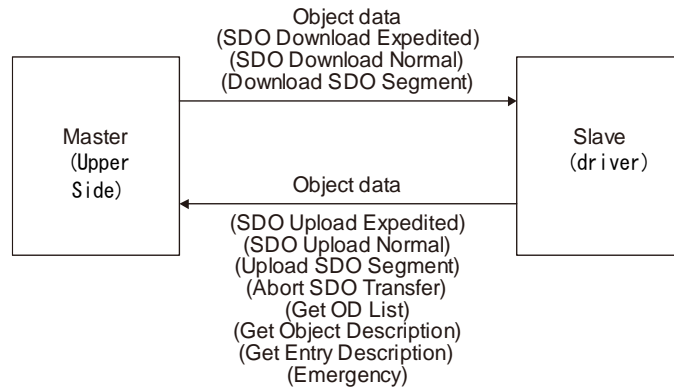

18.4.1 SDO communication-related service

The driver supports the following services relating to the SDO communication.

Service	Description
SDO Download Expedited	Writes data of up to 4 bytes to a slave.
SDO Download Normal	Writes data of the specified bytes to a slave.
Download SDO Segment	Writes additional data when the object size is larger than the specified byte size.
SDO Upload Expedited	Reads data of up to 4 bytes from a slave.
SDO Upload Normal (Note)	Reads data of the specified bytes from a slave.
Upload SDO Segment	Reads additional data when the object size is larger than the specified number of octets.
Abort SDO Transfer	Sends SDO Abort Code when an error occurs in a service.
Get OD List	Reads a list of available object indexes.
Get Object Description	Reads the detail of an index.
Get Entry Description	Reads the detail of Sub Index.
Emergency	Notifies an alarm.

Note. Complete Access is not supported.

18. EtherCAT COMMUNICATION

18.4.2 SDO Abort Code

When an error occurs in the SDO communication, the following error messages are returned with the Abort SDO Transfer service.

SDO Abort Code	Meaning	Cause
0504 0005h	Out of memory.	The memory is out of the range.
0601 0001h	Attempt to read to a write only object	Reading is attempted to a write-only object.
0601 0002h	Attempt to write to a read only object	Writing is attempted to a read-only object.
0601 0006h	Object mapped to RxPDO, SDO download blocked.	SDO Download is executed to an object mapped to RxPDO.
0602 0000h	The object does not exist in the object dictionary	A non-existent index is specified.
0604 0043h	General parameter incompatibility reason.	An unsupported command is issued.
0607 0012h	Data type does not match, length of service parameter too high.	The data type does not match. The data length is too long.
0607 0013h	Data type does not match, length of service parameter too short.	The data type does not match. The data length is too short.
0609 0011h	Subindex does not exist	A non-existent Sub Index is specified.
0609 0030h	Value range of parameter exceeded	A parameter value outside the range is specified.
0609 0031h	Value of parameter written too high	The value of the parameter written is too large.
0609 0032h	Value of parameter written too low	The value of the parameter written is too small.
0800 0000h	Generic error.	General error
0800 0021h	Data cannot be transferred or stored to the application because of local control.	Writing is limited in the device.
0800 0022h	Data cannot be transferred or stored to the application because of the present device state.	Data cannot be read or written due to the current device status.

18.5 CiA 402 DRIVE PROFILE

18.5.1 FSA state

The inside state of the _ driver is controlled based on the FSA state, defined in the CiA 402 drive profile standard. Figure 5.1 and Table 5.1 show the transition conditions between the FSA states. The states are switched when the master sends a command following the table (sets Controlword) with the PDO communication established (the AL state Operational reached). When the state has transitioned from Not ready to switch on, which is right after the power on, to Operation enabled with the predetermined procedure, the servo motor becomes ready to operate.

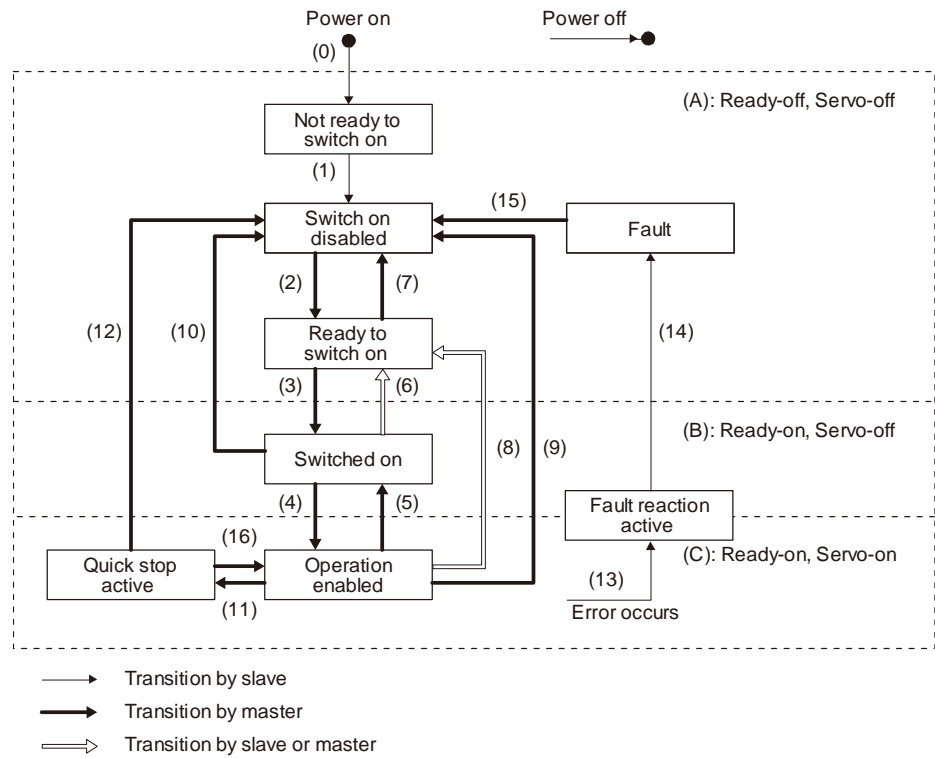

Figure 5.1 Transition between the FSA states

Table 5.1 State transition

Transition No.	Event	Remark
(0)	The control circuit power supply is turned on.	Initialization
(1)	The state automatically transitions when the control circuit power supply is turned on.	Communication setting
(2)	The state transitions with the Shutdown command from the master.	
(3)	The state transitions with the Switch on command from the master.	RA turns on.
(4)	The state transitions with the Enable operation command from the master.	The operation becomes ready after servo-on.
(5)	The state transitions with the Disable operation command from the master.	The operation is disabled after servo-off.
(6)	The state transitions with the Shutdown command from the master.	RA turns off.
(7)	The state transitions with the Disable Voltage command or Quick Stop command from the master.	
(8)	(a) The state transitions with the Shutdown command from the master. (b) The state transitions when the main circuit power supply is turned off.	Operation is disabled after servo-off or RA-off.
(9)	The state transitions with the Disable Voltage command from the master.	Operation is disabled after servo-off or RA-off.
(10)	The state transitions with the Disable Voltage command or Quick Stop command from the master.	RA turns off.
(11)	The state transitions with the Quick Stop command from the master.	Quick Stop starts.
(12)	(a) The state automatically transitions after Quick Stop is completed. (If the Quick Stop option code is 1, 2, 3, or 4) (b) The state transitions with the Disable Voltage command from the master.	Operation is disabled after servo-off or RA-off.
(13)	Alarm occurrence	Processing against the alarm is executed.

18. EtherCAT COMMUNICATION

Transition No.	Event	Remark
(14)	Automatic transition	After processing against the alarm has been completed, servo-off or RA-off is performed and the operation is disabled.
(15)	The state transitions with the Fault Reset command from the master.	Alarms are reset. Alarms that can be reset are reset.
(16) (Not supported) (Note)	The state transitions with the Enable Operation command from the master. (If the Quick Stop option code is 5, 6, 7, or 8)	The operation becomes ready.

Note. This is not supported by the driver.

The following table lists the commands issued to the driver. Turn on the bits according to the command.

Command	Command bit setting of Controlword					Transition No.
	Bit 7 Fault Reset	Bit 3 Enable Operation	Bit 2 Quick Stop	Bit 1 Enable Voltage	Bit 0 Switch On	
Shutdown	0	0	1	1	0	(2)/(6)/(8)
Switch On	0	0	1	1	1	(3)
Disable Voltage	0	0	1	0	1	(7)/(9)/(10)/(12)
Quick Stop	0	0	0	1	1	(7)/(10)/(11)
Disable Operation	0	0	1	1	1	(5)
Enable Operation	0	1	1	1	1	(4)/(16)
Fault Reset	0 → 1 (Note)	0	1	1	1	(15)

No te.	In faulty communication, hold the state of Bit 7 = 1 for at least 10 ms for the Fault Reset command to prevent the command from failing to be recognized.
--------	---

Figure 5.1 and Table 5.1 show the FSA state transition conditions of the EtherCAT standard. The transition from the Switch on disabled state to the Operation enabled state requires Shutdown, Switch on, and Enable operation to be issued in this order. However, with the driver, transition to the target state skipping the states in between is possible.

Current state	Command	State after transition
Switch on disabled	Switch on	Switched on
Switch on disabled	Enable operation	Operation enabled
Ready to switch on	Enable operation	Operation enabled

18. EtherCAT COMMUNICATION

18.5.2 Controlword/Control DI

The FSA state can be switched and control commands for the functions of the drive can be issued by rewriting the objects of Controlword (6040h) and Control DI (2D01h to 2D03h) from the master (upper side). Use 6040h to issue control commands defined with CiA 402. Use 2D01h to 2D03h to issue control commands of the other manufacturer functions.

Index	Sub	Object	Name	Data Type	Access	Description
6040h		VAR	Controlword	U16	rw	
2D01h		VAR	Control DI 1	U16	rw	Control commands to control the driver can be set.
2D02h	Control DI 2					
2D03h	Control DI 3					

18.5.2.1 Bit definition of Controlword

Controlword (6040h) can control the FSA state and issue control commands. Use Bit 0 to Bit 3 and Bit 7 for the FSA state. The following table shows the bit definition of Controlword (6040h).

Bit	Symbol	Description
0	SO	Switch-on
1	EV	Enable voltage
2	QS	Quick stop
3	EO	Enable operation
4	OMS	Differs depending on Modes of operation (6060h). (Refer to section 5.4.)
5		
6		
7	FR	Fault reset
8	HALT	0: Operation ready 1: Temporary stop
9	OMS	Differs depending on Modes of operation (6060h). (Refer to section 5.4.)
10		The value at reading is undefined. Set "0" at writing.
11		
12		
13		
14		
15		

18. EtherCAT COMMUNICATION

18.5.2.2 Bit definition of Control DI

Control DI can control the FSA state and issue control commands. The following table shows the bit definition of Control DI.

(1) Control DI 1

Bit	Symbol	Description
0		The value at reading is undefined. Set "0" at writing.
1		
2		
3		
4	C_CDP	Gain switching Turn on C_CDP to use the values of [Pr. PB29] to [Pr. PB36] and [Pr. PB56] to [Pr. PB60] as the load to motor inertia ratio and gain values.
5	C_CLD	Fully closed loop control switching Use this bit when the semi closed loop control/fully closed loop control switching is enabled with [Pr. PE01]. Turn off C_CLD to select the semi closed loop control, and turn on C_CLD to select the fully closed loop control.
6		The value at reading is undefined. Set "0" at writing.
7		
8		
9		
10		
11		
12		
13		
14		
15		

(2) Control DI 2

Bit	Symbol	Description
0		The value at reading is undefined. Set "0" at writing.
1		
2		
3		
4		
5		
6		
7		
8	C_PC	Proportional control Turn C_PC on to switch the speed amplifier from the proportional integral type to the proportional type. If the servo motor at a stop is rotated even one pulse due to any external factor, it generates torque to compensate for a position mismatch. When the servo motor shaft is to be locked mechanically after positioning completion (stop), switching on the C_PC upon positioning completion will suppress the unnecessary torque generated to compensate for a position mismatch. When the shaft is to be locked for a long time, use the C_PC and torque limit at the same time to make the torque less than the rated torque.
9		The value at reading is undefined. Set "0" at writing.
10		
11		
12		
13		
14		
15	C_ORST	Operation alarm reset Turn on C_ORST from off to reset [AL. F4 Positioning warning].

(3) Control DI 3

Bit	Symbol	Description
0		The value at reading is undefined. Set "0" at writing.
1		
2		
3		
4		
5		
6		
7		
8	C_ABS2	Home position return completion (for scale measurement) When C_ABS2 is turned on with the scale measurement function, the absolute position erased status of a scale measurement encoder can be canceled. S_ABSV2 turns off.
9		The value at reading is undefined. Set "0" at writing.
10		
11		
12		
13		
14		
15		

18. EtherCAT COMMUNICATION

18.5.3 Statusword/Status DO

The objects of Statusword or Status DO notify the master (upper side) of the FSA state of the _ driver and other drive status. Use 6041h to notify the status defined with CiA 402. Use 2D11h to 2D13h, 2D15h and 2D17h for the other Vendor-specific statuses.

Index	Sub	Object	Name	Data Type	Access	Description
6041h		VAR	Statusword	U16	ro	
2D11h		VAR	Status DO 1	U16	ro	The servo status is returned.
2D12h	Status DO 2					
2D13h	Status DO 3					
2D15h	Status DO 5					
2D17h	Status DO 7					

18.5.3.1 Bit definition of Statusword

The following table shows the bit definition of Statusword.

Bit	Symbol	Description
0	RTSO	Ready-to-switch-on
1	SO	Switch-on
2	OE	Operation-enabled
3	F	Fault
4	VE	Voltage-enabled 0: The bus voltage is lower than the certain (RA) level. 1: The bus voltage is equal to or higher than the certain level.
5	QS	Quick stop 0: During a quick stop 1: No during a quick stop (including during the test mode)
6	SOD	Switch on disabled
7	W	Warning 0: No warning has been occurred. 1: A warning has occurred.
8		The value at reading is undefined.
9	RM	Remote 0: Not following the Controlword command 1: In operation following the Controlword command
10	TR	Target reached Differs depending on Modes of operation (6060h). (Refer to section 5.4.)
11	ILA	Internal limit active 0: The forward rotation stroke end, reverse rotation stroke end, and software position limit have not been reached 1: The forward rotation stroke end, reverse rotation stroke end, or software position limit has been reached. (Enabled in the csp, csv, pp, pv, hm, pt, jg, or idx mode)
12	OMS	Differs depending on Modes of operation (6060h). (Refer to section 5.4.)
13		
14		
15		The value at reading is undefined.

18. EtherCAT COMMUNICATION

Bit 0 to Bit 3, Bit 5, and Bit 6 are switched depending on the FSA state (internal state of the driver). Refer to the following table for details.

Statusword (bin)	FSA state
x0xx xxx0 x0xx 0000	Not ready to switch on (Note)
x0xx xxx0 x1xx 0000	Switch on disabled
x0xx xxx0 x01x 0001	Ready to switch on
x0xx xxx0 x01x 0011	Switched on
x0xx xxx0 x01x 0111	Operation enabled
x0xx xxx0 x00x 0111	Quick stop active
x0xx xxx0 x0xx 1111	Fault reaction active
x0xx xxx0 x0xx 1000	Fault

Note. Statusword is not sent in the Not ready to switch on state.

18.5.3.2 Bit definition of Status DO

The following table shows the bit definition of Status DO.

(1) Status DO 1

Bit	Symbol	Description
0		The value at reading is undefined.
1		
2	S_SA	Speed reached S_SA turns off during servo-off. When the servo motor speed reaches the following range, S_SA turns on. Preset speed $\pm ((\text{Preset speed} \times 0.05) + 20)$ r/min When the preset speed is 20 r/min or slower, S_SA always turns on.
3	S_MBR	Electromagnetic brake interlock When a servo-off status or alarm occurs, S_MBR turns off.
4	S_CDPS	Variable gain selection S_CDPS will turn on during variable gain.
5	S_CLD	During fully closed loop control switching S_CLD turns on during fully closed loop control.
6		The value at reading is undefined.
7		
8		
9		
10		
11		
12	S_INP	In-position When the number of droop pulses is in the in-position range, S_INP turns on. The in-position range can be changed with [Pr. PA10]. When the in-position range is increased, S_INP may be always on during low-speed rotation. The Status DO cannot be used in the velocity mode or torque mode.
13	S_TLC	Limiting torque When the torque reaches the torque limit value during torque generation, S_TLC turns on. When the servo is off, S_TLC will be turned off. This Status DO cannot be used in the torque mode.
14	S_ABSV	Absolute position undetermined When the absolute position is erased, S_ABSV turns on. The Status DO cannot be used in the velocity mode or torque mode.
15	S_BWNG	Battery warning When [AL. 92 Battery cable disconnection warning] or [AL. 9F Battery warning] has occurred, S_BWNG turns on. When the battery warning is not occurring, turning on the power will turn off S_BWNG after 2.5 s to 3.5 s.

(2) Status DO 2

Bit	Symbol	Description
0	S_ZPAS	Z-phase already passed 0: Z-phase unpassed after start-up 1: Z-phase passed once or more after start-up
1		The value at reading is undefined.
2		
3	S_ZSP	Zero speed detection When the servo motor speed is at zero speed or slower, S_ZSP turns on. Zero speed can be changed with [Pr. PC07].
4	S_VLC	Limiting speed When the speed reaches the speed limit value in the torque mode, S_VLC turns on. When the servo is off, S_TLC will be turned off. The Status DO cannot be used in the position mode or velocity mode.
5		The value at reading is undefined.
6		S_IPF
7		
8	S_PC	Under proportional control S_PC turns on under proportional control.
9		The value at reading is undefined.
10	S_DB	External dynamic brake output When the dynamic brake needs to operate, S_DB turns off.
11		The value at reading is undefined.
12		
13		
14		
15	S_ZP2	Home position return completion 2 (incremental system) When a home position return completes normally, S_ZP2 turns on. S_ZP2 is always on unless the home position is erased. It will be off with the following conditions. 1) [AL. 69 Command error] occurs. 2) Home position return is not being executed. 3) Home position return is in progress.
		Home position return completion 2 (absolute position detection system) If a home position return completes once, S_ZP2 is always on. However, it will be off with the following conditions. 1) [AL. 69 Command error] occurs. 2) Home position return is not being executed. 3) Home position return is in progress. 4) The home position return is not performed after [AL. 25 Absolute position erased] or [AL. E3 Absolute position counter warning] occurred. 5) The home position return is not performed after the electronic gear ([Pr. PA06] or [Pr. PA07]) was changed. 6) The home position return is not performed after the setting of [Pr. PA03 Absolute position detection system selection] was changed from "Disabled" to "Enabled". 7) [Pr. PA14 Rotation direction selection] was changed. 8) [Pr. PA01 Operation mode] was changed.

18. EtherCAT COMMUNICATION

(3) Status DO 3

Bit	Symbol	Description
0		The value at reading is undefined.
1		
2		
3		
4		
5	S_STO	During STO S_STO turns on during STO.
6		The value at reading is undefined.
7		
8	S_ABSV2	Absolute position undetermined 2 (for scale measurement) When the absolute position is erased from a scale measurement encoder with the scale measurement function, S_ABSV2 turns on.
9		The value at reading is undefined.
10		
11	S_MTTR	Transition to tough drive mode in process When a tough drive is "Enabled" in [Pr. PA20], activating the instantaneous power failure tough drive will turn on S_MTTR.
12		The value at reading is undefined.
13		
14		
15		

(4) Status DO 5

Bit	Symbol	Description
0		The value at reading is undefined.
1		
2		
3		
4		
5	S_CPO	Rough match When a command remaining distance is lower than the rough match output range set with [Pr. PT12], S_CPO turns on.
6	S_MEND	Travel completion When the droop pulses are within the in-position output range set with [Pr. PA10] and the command remaining distance is "0", S_MEND turns on. S_MEND turns on with servo-on. S_MEND is off at servo-off status. However, S_MEND will not be off in the indexer method.
7		The value at reading is undefined.
8		
9		
10		
11		
12		
13		
14		
15		

18. EtherCAT COMMUNICATION

(5) Status DO 7

Bit	Symbol	Description
0		The value at reading is undefined.
1		
2	S_POT	Position range output When an actual current position is within the range set with [Pr. PT19] to [Pr. PT22], S_POT turns on. This will be off when a home position return is not completed or base circuit shut-off is in progress.
3		The value at reading is undefined.
4		
5		
6		
7		
8		
9		
10		
11		
12		
13		
14		
15		

18. EtherCAT COMMUNICATION

18.5.4 Control mode

18.5.4.1 Selecting control mode (Modes of operation)

Specify a control mode with Modes of operation (6060h). Modes of operation (6060h) can be rewritten with PDO or SDO. Note that usable control modes are limited depending on the setting of [Pr. PA01], as shown in the following table.

Pr. PA01 setting value	pp	pv	tq	hm	csp	csv	cst	ig	pt	idx	6060h/6061h Default value
___ 0: Automatic selection by each network	/	/	/	○	○	○	○	/	/	/	8 (csp)
___ 1: Cyclic synchronous mode	/	/	/	○	○	○	○	/	/	/	8 (csp)
___ 2: Profile mode	○	○	○	○	/	/	/	/	/	/	1 (pp)
___ 6: Positioning mode (point table method)	/	/	/	○	/	/	/	○	○	/	-101 (pt)
___ 8: Positioning mode (indexer method)	/	/	/	○	/	/	/	○	/	○	-103 (idx)

The following table shows the objects selected for control modes.

Index	Sub	Object	Name	Data Type	Access	Default	Description
6060h	/	VAR	Modes of operation	I8	rw	Differs depending on [Pr. PA01].	Refer to section 7.3.8 (6).
6061h	/	VAR	Modes of operation display	I8	ro	Differs depending on [Pr. PA01].	Refer to section 7.3.8 (7).
6502h	/	VAR	Supported drive mode	U32	ro	Refer to section 7.3.8 (8).	Refer to section 7.3.8 (8).

18.5.4.2 Control switching

POINT
<ul style="list-style-type: none"> ● Changes to the OMS bit of Controlword (6040h) are not accepted until control switching is completed. Before inputting commands, check that the control mode has been switched referring to Modes of operation display (6061h).

Because control switching has a delay, the upper side must keep sending command values corresponding to the control mode before and after the switching. After the completion of control switching has been checked with Modes of operation display (6061h), update of the command value before the switching can be stopped. Before switching the mode from or to the position mode, check that the servo motor speed is zero speed. Zero speed can be obtained with Bit 3 (S_ZSP) of Status DO 2 (2D12h). If the servo motor speed is not zero speed, the control will not be switched and Modes of operation display (6061h) will not change.

18. EtherCAT COMMUNICATION

18.5.4.3 Cyclic synchronous position mode (csp)

The following shows the functions and related objects of the cyclic synchronous position mode (csp).

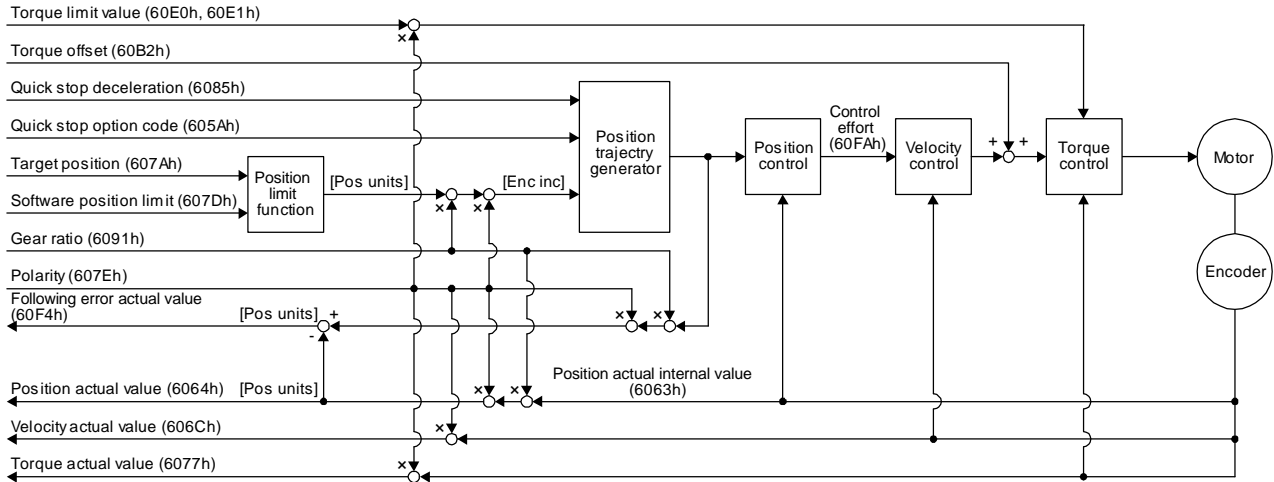

(1) Related object

Index	Sub	Object	Name	Data Type	Access	Default	Description
607Ah		VAR	Target position	I32	rw		Command position (Pos units)
607Bh (Note 2)	0	ARRAY	Position range limit	U8	ro	2	Number of entries
	1		Min position range limit	I32	rw		Minimum value of the position range limit The value is automatically set according to the setting of "Position data unit" in [Pr. PT01]. pulse: -2147483648 degree: 0 The cyclic synchronous mode supports pulses only.
	2		Max position range limit	I32	rw		Maximum value of the position range limit The value is automatically set according to the setting of "Position data unit" in [Pr. PT01]. pulse: 2147483647 degree: 359999 The cyclic synchronous mode supports pulses only.
607Dh	0	ARRAY	Software position limit	U8	ro	2	Number of entries
	1		Min position limit	I32	rw	0	Minimum position address (Pos units)
	2		Max position limit	I32	rw	0	Maximum position address (Pos units)
6085h		VAR	Quick stop deceleration	U32	rw	100	Deceleration at deceleration to a stop by Quick stop Unit: ms
605Ah		VAR	Quick stop option code	I16	rw	2	Operation setting for Quick stop Refer to section 5.6.
6080h		VAR	Max motor speed	U32	rw	Refer to chap7	Servo motor maximum speed Unit: r/min
6063h		VAR	Position actual internal value	I32	ro		Current position (after electronic gear)
6064h		VAR	Position actual value	I32	ro		Current position (command unit)
606Ch		VAR	Velocity actual value	I32	ro		Current speed Unit: 0.01 r/min

18. EtherCAT COMMUNICATION

Index	Sub	Object	Name	Data Type	Access	Default	Description
6077h		VAR	Torque actual value	I32	ro		Current torque Unit: 0.1% (rated torque of 100%)
6092h	0	ARRAY	Feed constant	U8	ro	2	Travel distance per revolution of an output shaft
	1		Feed	U32	rw		Travel distance Refer to section 7.3.14 (4).
	2		Shaft revolutions				Number of servo motor shaft revolutions Refer to section 7.3.14 (4).
60F4h		VAR	Following error actual value	I32	ro		Droop pulses (Pos units)
60FAh		VAR	Control effort	I32	ro		Position control loop output (speed command) Unit: Vel unit (0.01 r/min or 0.01 mm/s)
60E0h		VAR	Positive torque limit value	U16	rw	10000	Torque limit value (forward) Unit: 0.1% (rated torque of 100%)
60E1h		VAR	Negative torque limit value	U16	rw	10000	Torque limit value (reverse) Unit: 0.1% (rated torque of 100%)
6091h	0	ARRAY	Gear ratio	U8	ro	2	Gear ratio
	1		Motor revolutions	U32	rw		Number of revolutions of the servo motor axis (numerator) (Note 1)
	2		Shaft revolutions				Number of revolutions of the drive axis (denominator) (Note 1)
607Eh		VAR	Polarity	U8	rw	0	Polarity selection Bit 7: Position POL Bit 6: Velocity POL Bit 5: Torque POL (Note 2) Refer to section 5.10.
60A8h		VAR	SI unit position	U32	rw	0	SI unit position The value is automatically set according to the setting of "Position data unit" of [Pr. PT01]. Refer to section 7.3.14 (5).
60A9h		VAR	SI unit velocity	U32	rw	0	SI unit velocity 0.01 r/min or 0.01 mm/s FB010300h (0.01 mm/s) FEB44700h (0.01 r/min)
60B2h		VAR	Torque offset	I16	rw	0	Torque offset Unit: 0.1% (rated torque of 100%) This can be set within -32768 to 32767. When this is set to a value exceeding the maximum torque of the driver, the value is clamped at the maximum torque. Refer to section 5.12.

18. EtherCAT COMMUNICATION

(2) Electronic gear function (unit conversion for position data)

The unit system of position data used inside and outside the driver can be mutually converted with the Gear ratio value used as a coefficient.

Outside/inside	Applicable object example	Unit notation
External position information (position information exchanged with the upper side)	Current position (Position actual value (6064h)) Command position (Target position (607Ah))	Pos units
Internal position information (position information in the driver)	Internal current position (Position actual internal value (6063h))	Enc inc

The following shows the equation.

$$\text{Position actual value (6064h)} = \frac{\text{Position actual internal value (6063h)} \times \text{Feed constant (6092h)}}{\text{Position encoder resolution (608Fh)} \times \text{Gear ratio (6091h)}}$$

$$\text{Position actual internal value (6063h)} \times \frac{\text{Shaft revolutions (6091h: 2)}}{\text{Motor revolutions (6091h: 1)}}$$

(3) OMS bit of Controlword (csp mode)

Bit	Symbol	Description
4	(reserved)	The value at reading is undefined. Set "0" at writing.
5	(reserved)	
6	(reserved)	
8	(reserved)	
9	(reserved)	

(4) OMS bit of Statusword (csp mode)

Bit	Symbol	Description
10	(reserved)	The value at reading is undefined.
12	Target position ignored	0: Target position (607Ah) is being discarded. 1: Target position (607Ah) is being used as a position control loop input.
13	Following error	0: No following error 1: Following error Judgment condition for Following error When the time set with Following error time out (6066h) has elapsed with the number of droop pulses exceeding the set value of the Following error window (6065h), this bit becomes "1".

18.5.4.4 Cyclic synchronous velocity mode (csv)

The following shows the functions and related objects of the cyclic synchronous velocity mode (csv).

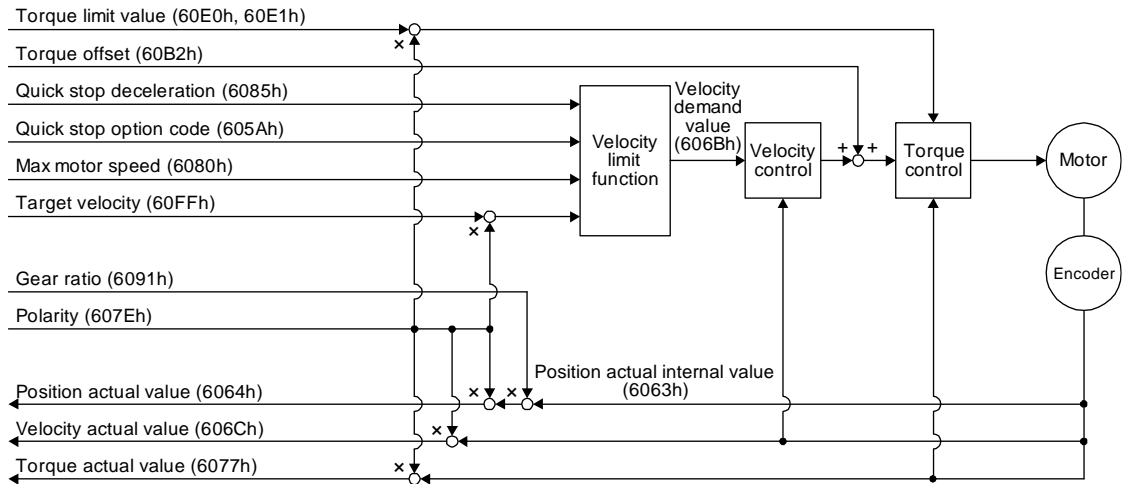

(1) Related object

Index	Sub	Object	Name	Data Type	Access	Default	Description
60FFh		VAR	Target velocity	I32	rw		Command speed Unit: Vel unit (0.01 r/min or 0.01 mm/s)
6085h		VAR	Quick stop deceleration	U32	rw	100	Deceleration at deceleration to a stop by Quick stop Unit: ms
605Ah		VAR	Quick stop option code	I16	rw	2	Operation setting for Quick stop Refer to section 5.6.
6080h		VAR	Max motor speed	U32	rw		Servo motor maximum speed Unit: r/min
606Bh		VAR	Velocity demand value	I32	ro		Command speed (after limit)
6063h		VAR	Position actual internal value	I32	ro		Current position (after electronic gear)
6064h		VAR	Position actual value	I32	ro		Current position (command unit)
606Ch		VAR	Velocity actual value	I32	ro		Current speed Unit: 0.01 r/min
6077h		VAR	Torque actual value	I32	ro		Current torque Unit: 0.1% (rated torque of 100%)
6092h	0	ARRAY	Feed constant	U8	ro	2	Travel distance per revolution of an output shaft
	1		Feed	U32	rw		Travel distance Refer to section 7.3.14 (4).
	2		Shaft revolutions				Number of servo motor shaft revolutions Refer to section 7.3.14 (4).
60E0h		VAR	Positive torque limit value	U16	rw	10000	Torque limit value (forward) Unit: 0.1% (rated torque of 100%)
60E1h		VAR	Negative torque limit value	U16	rw	10000	Torque limit value (reverse) Unit: 0.1% (rated torque of 100%)

18. EtherCAT COMMUNICATION

Index	Sub	Object	Name	Data Type	Access	Default	Description
6091h	0	ARRAY	Gear ratio	U8	ro	2	Gear ratio
	1		Motor revolutions	U32	rw	1	Number of revolutions of the servo motor axis (numerator) (Note 1)
	2		Shaft revolutions			1	Number of revolutions of the drive axis (denominator) (Note 1)
607Eh		VAR	Polarity	U8	rw	0	Polarity selection Bit 7: Position POL Bit 6: Velocity POL Bit 5: Torque POL Refer to section 5.10.
60A8h		VAR	SI unit position	U32	rw	0	SI unit position The value is automatically set according to the setting of "Position data unit" of [Pr. PT01]. Refer to section 7.3.14 (5).
60A9h		VAR	SI unit velocity	U32	rw	0	SI unit velocity 0.01 r/min or 0.01 mm/s FB010300h (0.01 mm/s) FEB44700h (0.01 r/min)
60B2h		VAR	Torque offset	I16	rw	0	Torque offset Unit: 0.1% (rated torque of 100%) This can be set within -32768 to 32767. When this is set to a value exceeding the maximum torque of the driver, the value is clamped at the maximum torque. Refer to section 5.12.

(2) OMS bit of Controlword (csv mode)

Bit	Symbol	Description
4	(reserved)	The value at reading is undefined. Set "0" at writing.
5	(reserved)	
6	(reserved)	
8	(reserved)	
9	(reserved)	

(3) OMS bit of Statusword (csv mode)

Bit	Symbol	Description
10	(reserved)	The value at reading is undefined.
12	Target velocity ignored	0: Target velocity (60FFh) is being discarded. 1: Target velocity (60FFh) is being used as a speed control loop input.
13	(reserved)	The value at reading is undefined.

18. EtherCAT COMMUNICATION

18.5.4.5 Cyclic synchronous torque mode (cst)

The following shows the functions and related objects of the cyclic synchronous torque mode (cst).

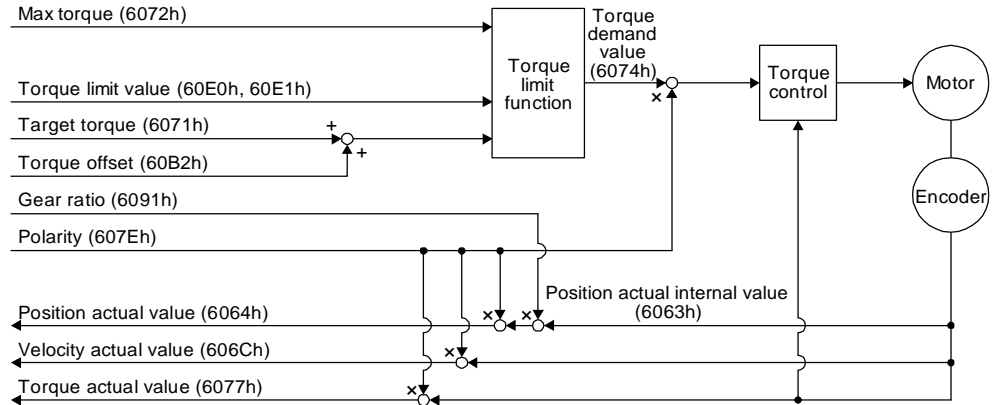

(1) Related object

Index	Sub	Object	Name	Data Type	Access	Default	Description
6071h		VAR	Target torque	I16	rw		Command torque Unit: 0.1% (rated torque of 100%)
6072h		VAR	Max torque	U16	rw		Maximum torque Unit: 0.1% (rated torque of 100%)
6074h		VAR	Torque demand	I16	ro		Command torque (after limit) Unit: 0.1% (rated torque of 100%)
6063h		VAR	Position actual internal value	I32	ro		Current position (Enc inc)
6064h		VAR	Position actual value	I32	ro		Current position (Pos units)
606Ch		VAR	Velocity actual value	I32	ro		Current speed Unit: Vel unit (0.01 r/min or 0.01 mm/s)
6077h		VAR	Torque actual value	I32	ro		Current torque Unit: 0.1% (rated torque of 100%)
6092h	0	ARRAY	Feed constant	U8	ro	2	Travel distance per revolution of an output shaft
	1		Feed	U32	rw		Travel distance Refer to section 7.3.14 (4).
	2		Shaft revolutions				Number of servo motor shaft revolutions Refer to section 7.3.14 (4).
60E0h		VAR	Positive torque limit value	U16	rw	10000	Torque limit value (forward) Unit: 0.1% (rated torque of 100%)
60E1h		VAR	Negative torque limit value	U16	rw	10000	Torque limit value (reverse) Unit: 0.1% (rated torque of 100%)
6091h	0	ARRAY	Gear ratio	U8	ro	2	Gear ratio
	1		Motor revolutions	U32	rw	1	Number of revolutions of the servo motor axis (numerator)
	2		Shaft revolutions			1	Number of revolutions of the drive axis (denominator)
607Eh		VAR	Polarity	U8	rw	0	Polarity selection Bit 7: Position POL Bit 6: Velocity POL Bit 5: Torque POL Refer to section 5.10.

Index	Sub	Object	Name	Data Type	Access	Default	Description
-------	-----	--------	------	-----------	--------	---------	-------------

18. EtherCAT COMMUNICATION

2D20h		VAR	Velocity limit value	I32	rw	50000	Speed limit value Unit: Vel unit (0.01 r/min or 0.01 mm/s)
60A8h		VAR	SI unit position	U32	rw	0	SI unit position The value is automatically set according to the setting of "Position data unit" of [Pr. PT01]. Refer to section 7.3.14 (5).
60A9h		VAR	SI unit velocity	U32	rw	0	SI unit velocity 0.01 r/min or 0.01 mm/s FB010300h (0.01 mm/s) FEB44700h (0.01 r/min)
60B2h		VAR	Torque offset	I16	rw	0	Torque offset Unit: 0.1% (rated torque of 100%) This can be set within -32768 to 32767. When this is set to a value exceeding the maximum torque of the driver, the value is clamped at the maximum torque. Refer to section 5.12.

(2) OMS bit of Controlword (cst mode)

Bit	Symbol	Description
4	(reserved)	The value at reading is undefined. Set "0" at writing.
5	(reserved)	
6	(reserved)	
8	(reserved)	
9	(reserved)	

(3) OMS bit of Statusword (cst mode)

Bit	Symbol	Description
10	(reserved)	The value at reading is undefined.
12	Target torque ignored	0: Target torque (6071h) is being discarded. 1: Target torque (6071h) is being used as a torque control loop input.
13	(reserved)	The value at reading is undefined.

18.5.4.6 Profile position mode (pp)

The following shows the functions and related objects of the profile position mode (pp).

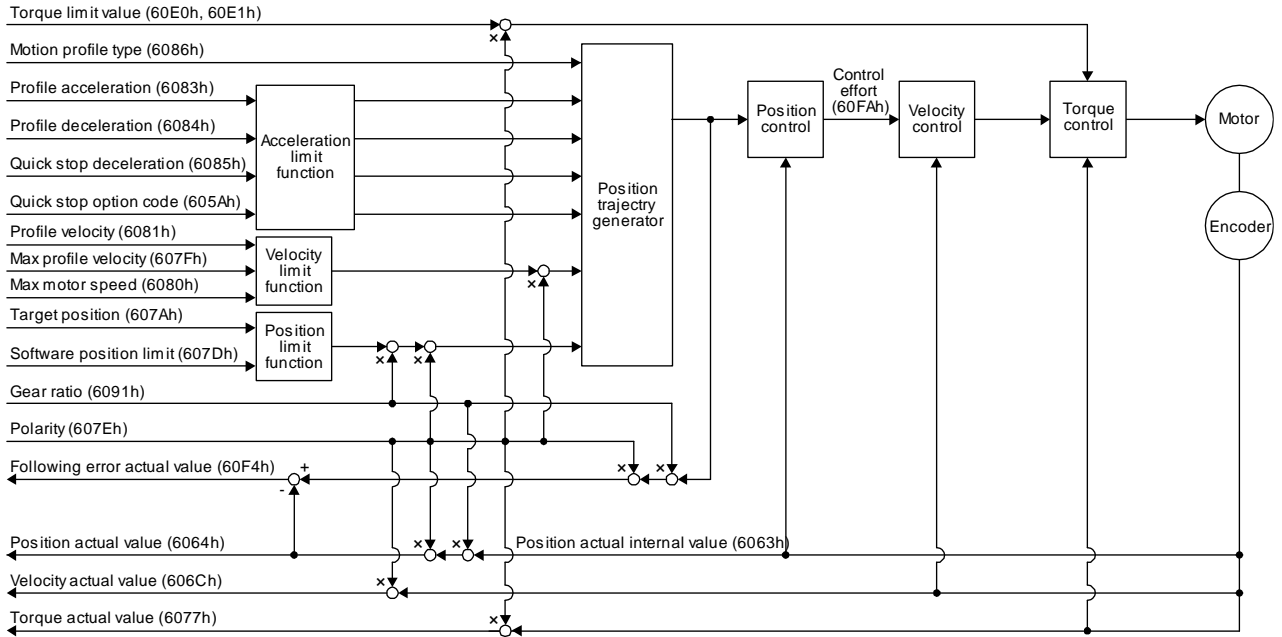

(1) Related object

Index	Sub	Object	Name	Data Type	Access	Default	Description
607Ah		VAR	Target position	I32	rw		Command position (Pos units)
607Bh	0	ARRAY	Position range limit	U8	ro	2	Number of entries
	1		Min position range limit	I32	rw		Minimum value of the position range limit The value is automatically set according to the setting of "Position data unit" in [Pr. PT01]. mm/inch/pulse: -2147483648 degree: 0 The cyclic synchronous mode supports pulses only.
	2		Max position range limit	I32	rw		Maximum value of the position range limit The value is automatically set according to the setting of "Position data unit" in [Pr. PT01]. mm/inch/pulse: 2147483647 degree: 359999 The cyclic synchronous mode supports pulses only.
607Dh	0	ARRAY	Software position limit	U8	ro	2	Number of entries
	1		Min position limit	I32	rw	0	Minimum position address (Pos units)
	2		Max position limit	I32	rw	0	Maximum position address (Pos units)
607Fh		VAR	Max profile velocity	U32	rw	2000000	maximum speed Unit: Vel unit (0.01 r/min or 0.01 mm/s)
6080h		VAR	Max motor speed	U32	rw		Servo motor maximum speed Unit: r/min

18. EtherCAT COMMUNICATION

Index	Sub	Object	Name	Data Type	Access	Default	Description
6081h		VAR	Profile velocity	U32	rw	10000	Speed after acceleration completed Unit: Vel unit (0.01 r/min or 0.01 mm/s)
6083h		VAR	Profile Acceleration	U32	rw	0	Acceleration at start of movement to target position Unit: ms
6084h		VAR	Profile deceleration	U32	rw	0	Deceleration at arrival at target position Unit: ms
6085h		VAR	Quick stop deceleration	U32	rw	100	Deceleration at deceleration to a stop by Quick stop Unit: ms
6086h		VAR	Motion profile type	I16	rw	-1	Acceleration/deceleration type selection -1: S-pattern 0: Linear ramp (not supported) (Note 1) 1: Sin ² ramp (not supported) (Note 1) 2: Jerk-free ramp (not supported) (Note 1) 3: Jerk-limited ramp (not supported) (Note 1)
605Ah		VAR	Quick stop option code	I16	rw	2	Operation setting for Quick stop Refer to section 5.6.
6063h		VAR	Position actual internal value	I32	ro		Current position (Enc inc)
6064h		VAR	Position actual value	I32	ro		Current position (Pos units)
606Ch		VAR	Velocity actual value	I32	ro		Current speed Unit: Vel unit (0.01 r/min or 0.01 mm/s)
6077h		VAR	Torque actual value	I32	ro		Current torque Unit: 0.1% (rated torque of 100%)
6092h	0	ARRAY	Feed constant	U8	ro	2	Travel distance per revolution of an output shaft
	1		Feed	U32	rw		Travel distance Refer to section 7.3.14 (4).
	2		Shaft revolutions				Number of servo motor shaft revolutions Refer to section 7.3.14 (4).
60F4h		VAR	Following error actual value	I32	ro		Droop pulses (Pos units)
60FAh		VAR	Control effort	I32	ro		Position control loop output (speed command) Unit: Vel unit (0.01 r/min or 0.01 mm/s)
60E0h		VAR	Positive torque limit value	U16	rw	10000	Torque limit value (forward) Unit: 0.1% (rated torque of 100%)
60E1h		VAR	Negative torque limit value	U16	rw	10000	Torque limit value (reverse) Unit: 0.1% (rated torque of 100%)
6091h	0	ARRAY	Gear ratio	U8	ro	2	Gear ratio
	1		Motor revolutions	U32	rw	1	Number of revolutions of the servo motor axis (numerator)
	2		Shaft revolutions			1	Number of revolutions of the drive axis (denominator)

18. EtherCAT COMMUNICATION

Index	Sub	Object	Name	Data Type	Access	Default	Description
607Eh		VAR	Polarity	U8	rw	0	Polarity selection Bit 7: Position POL Bit 6: Velocity POL Bit 5: Torque POL (Note 2) Refer to section 5.10.
60A8h		VAR	SI unit position	U32	rw	0	SI unit position The value is automatically set according to the setting of "Position data unit" of [Pr. PT01]. Refer to section 7.3.14 (5).
60A9h		VAR	SI unit velocity	U32	rw	0	SI unit velocity 0.01 r/min or 0.01 mm/s FB010300h (0.01 mm/s) FEB44700h (0.01 r/min)

Note 1. This is not supported by the driver.

(2) Details on the OMS bit of Controlword (pp mode)

Bit	Symbol	Description
4	New set-point	New positioning parameters are obtained when this bit turns on.
5	Change set immediately	0: Set of set-points 1: Single set-point
6	abs/rel	0: Absolute position command 1: Relative position command When the unit is set to degree, relative position commands are disabled. When the relative position command is specified and positioning is started, [AL. F4.8] occurs and positioning cannot be started.
8	HALT	0: Positioning is executed. 1: The servo motor stops according to Halt option code (605Dh).
9	Change on set-point	Enabled only for Set of set-points (Bit 5 = 0). 0: The next positioning starts after the current positioning is completed (stopped). (black line (Refer to (5) in this section.)) 1: The next positioning starts after positioning is executed with Profile velocity (6081h) held up to the current set-point. (gray line (Refer to (5) in this section.))

(3) Details on the OMS bit of Statusword (pp mode)

Bit	Symbol	Description
10	Target reached	0 (Halt (Bit 8) = 0): Target position not reached. 0 (Halt (Bit 8) = 1): Axis decelerates 1 (Halt (Bit 8) = 0): Target position reached. 1 (Halt (Bit 8) = 1): Velocity of axis is 0 Judgment condition for Target position reached If the error between Position actual value (6064h) and Target position (607Ah) has stayed within Position window (6067h) for Position window time (6068h) or more, Target position reached is stored.
12	Set-point acknowledge	0: Positioning completed (wait for next command) 1: Positioning being executed (The set-point can be overwritten.)
13	Following error	0: No following error 1: Following error Judgment condition for Following error When the time set with Following error time out (6066h) has elapsed with the number of droop pulses exceeding the set value of the Following error window (6065h), this bit becomes "1".

(4) Single Set-point

Update of positioning parameters during a positioning operation is immediately accepted. (The current positioning operation is cancelled and the next positioning is started.)

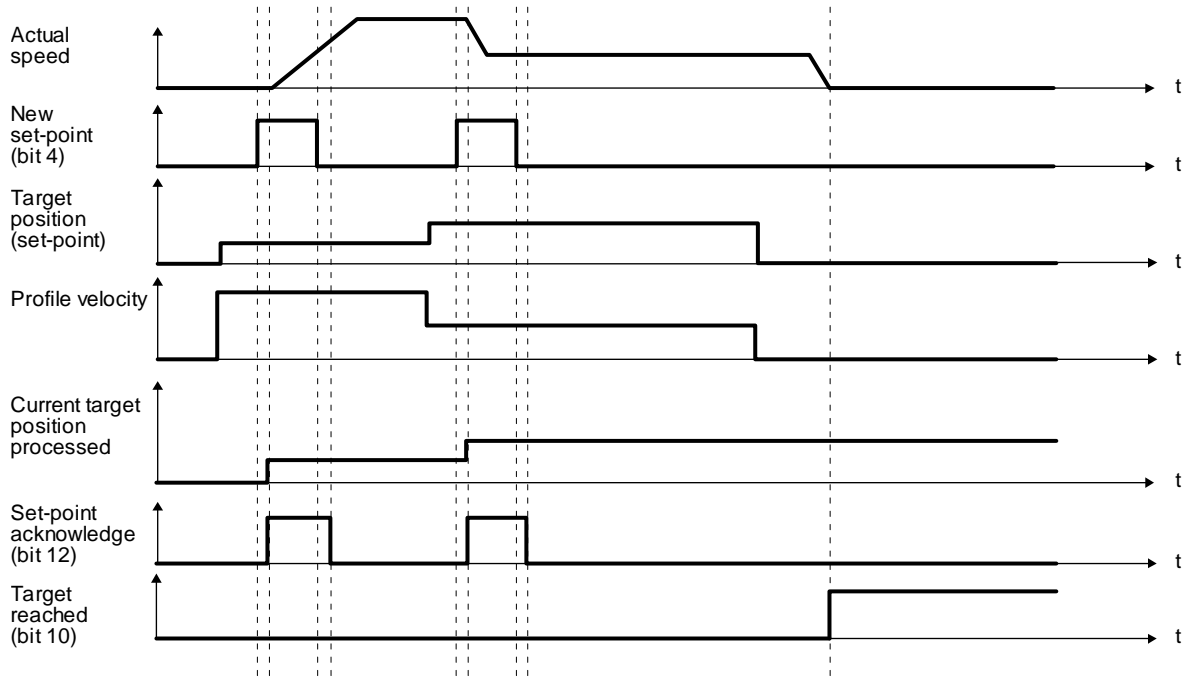

(5) Set of set-points

After the current positioning operation is completed, the next positioning is started. Whether positioning is stopped at the first positioning point when at an update of the positioning parameter before completion of the positioning can be switched. To switch the setting, use Change on set-point (Bit 9 of Controlword).

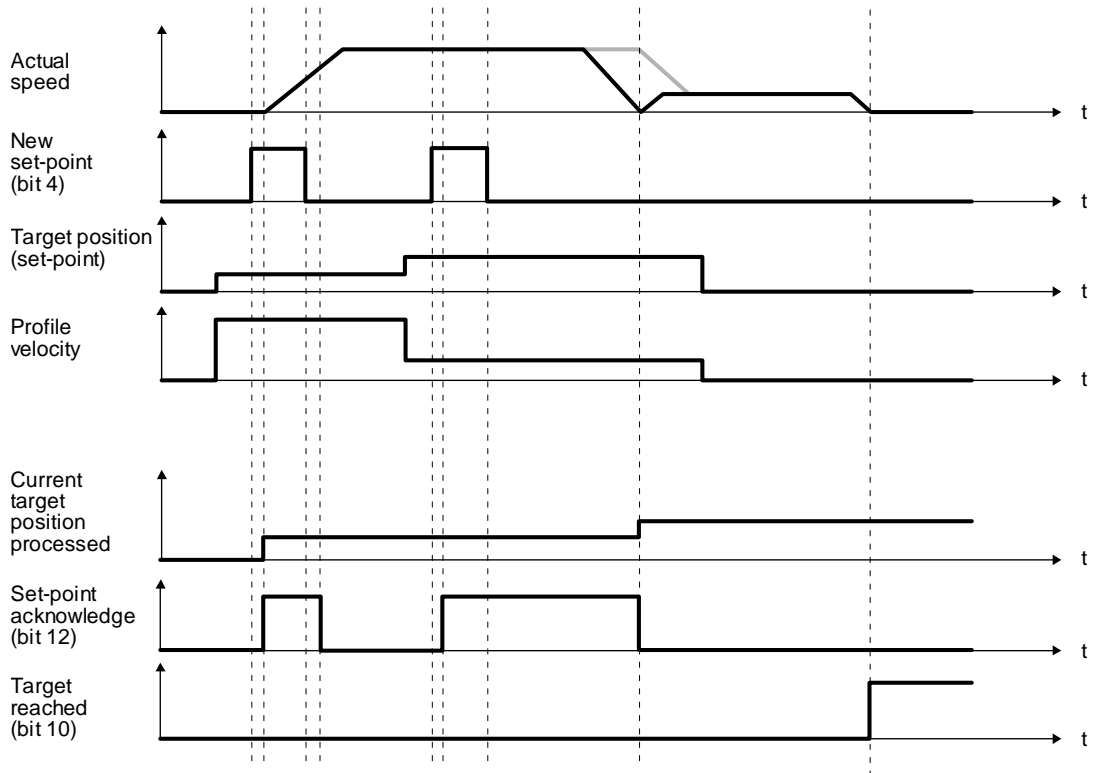

18.5.4.7 Profile velocity mode (pv)

The following shows the functions and related objects of the profile velocity mode (pv).

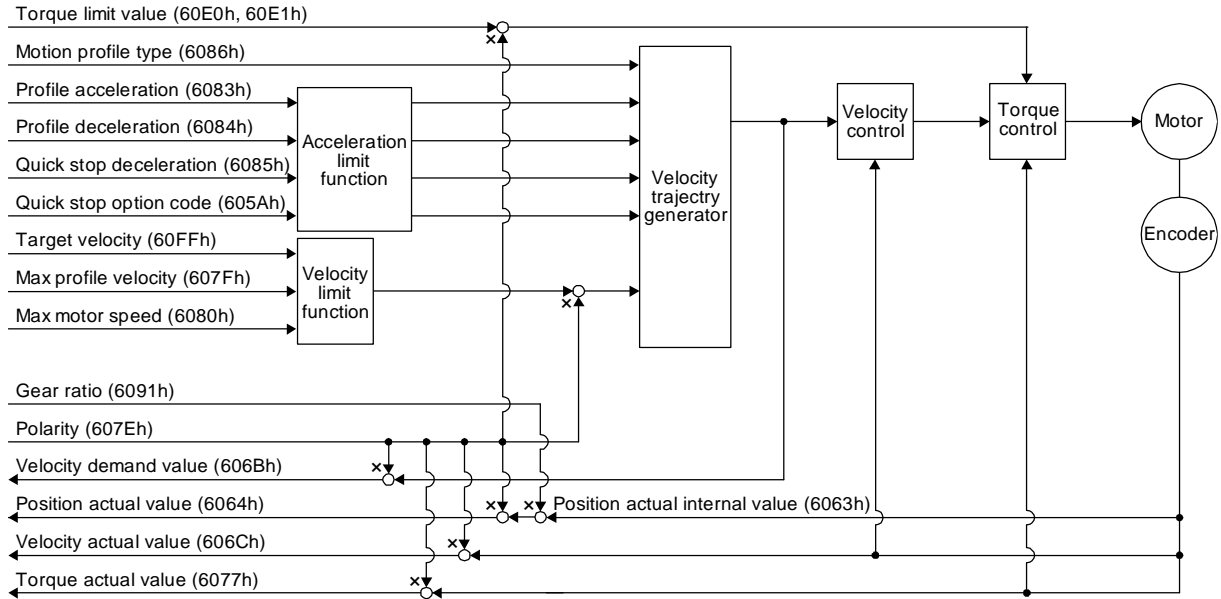

(1) Related object

Index	Sub	Object	Name	Data Type	Access	Default	Description
60FFh		VAR	Target velocity	I32	rw		Command speed Unit: Vel unit (0.01 r/min or 0.01 mm/s)
607Fh		VAR	Max profile velocity	U32	rw	2000000	maximum speed Unit: Vel unit (0.01 r/min or 0.01 mm/s)
6080h		VAR	Max motor speed	U32	rw		Servo motor maximum speed Unit: r/min
6083h		VAR	Profile Acceleration	U32	rw	0	Acceleration at start of movement to target position Unit: ms
6084h		VAR	Profile deceleration	U32	rw	0	Deceleration at arrival at target position Unit: ms
6085h		VAR	Quick stop deceleration	U32	rw	100	Deceleration at deceleration to a stop by Quick stop Unit: ms
6086h		VAR	Motion profile type	I16	rw	-1	Acceleration/deceleration type selection -1: S-pattern 0: Linear ramp (not supported) (Note 1) 1: Sin ² ramp (not supported) (Note 1) 2: Jerk-free ramp (not supported) (Note 1) 3: Jerk-limited ramp (not supported) (Note 1)
605Ah		VAR	Quick stop option code	I16	rw	2	Operation setting for Quick stop Refer to section 5.6.
6063h		VAR	Position actual internal value	I32	ro		Current position (Enc inc)

18. EtherCAT COMMUNICATION

Index	Sub	Object	Name	Data Type	Access	Default	Description
6064h		VAR	Position actual value	I32	ro		Current position (Pos units)

Index	Sub	Object	Name	Data Type	Access	Default	Description
606Bh		VAR	Velocity demand value	I32	ro		Speed command (after trajectory generation)
606Ch		VAR	Velocity actual value	I32	ro		Current speed Unit: Vel unit (0.01 r/min or 0.01 mm/s)
6077h		VAR	Torque actual value	I32	ro		Current torque Unit: 0.1% (rated torque of 100%)
6092h	0	ARRAY	Feed constant	U8	ro	2	Travel distance per revolution of an output shaft
	1		Feed	U32	rw		Travel distance Refer to section 7.3.14 (4).
	2		Shaft revolutions				Number of servo motor shaft revolutions Refer to section 7.3.14 (4).
60E0h		VAR	Positive torque limit value	U16	rw	10000	Torque limit value (forward) Unit: 0.1% (rated torque of 100%)
60E1h		VAR	Negative torque limit value	U16	rw	10000	Torque limit value (reverse) Unit: 0.1% (rated torque of 100%)
6091h	0	ARRAY	Gear ratio	U8	ro	2	Gear ratio
	1		Motor revolutions	U32	rw	1	Number of revolutions of the servo motor axis (numerator)
	2		Shaft revolutions			1	Number of revolutions of the drive axis (denominator)
607Eh		VAR	Polarity	U8	rw	0	Polarity selection Bit 7: Position POL Bit 6: Velocity POL Bit 5: Torque POL (Note 2) Refer to section 5.10.
606Dh		VAR	Velocity window	U16	rw	2000	Speed error threshold for judging Target reached Unit: 0.01 r/min or 0.01 mm/s
606Eh		VAR	Velocity window time	U16	rw	0	Target reached judgment time Unit: ms
606Fh		VAR	Velocity threshold	U16	rw	5000	Zero speed threshold for judging Speed Unit: 0.01 r/min or 0.01 mm/s
6070h		VAR	Velocity threshold time	U16	rw	10	Speed judgment time Unit: ms
60A8h		VAR	SI unit position	U32	rw	0	SI unit position The value is automatically set according to the setting of "Position data unit" of [Pr. PT01]. Refer to section 7.3.14 (5).
60A9h		VAR	SI unit velocity	U32	rw	0	SI unit velocity 0.01 r/min or 0.01 mm/s FB010300h (0.01 mm/s) FEB44700h (0.01 r/min)

Note 1. This is not supported by the driver.

(2) Details on the OMS bit of Controlword (pv mode)

Bit	Symbol	Description
4	(reserved)	The value at reading is undefined. Set "0" at writing.
5	(reserved)	
6	(reserved)	
8	HALT	0: The servo motor is driven. 1: The servo motor is stopped according to Halt option code (605Dh).
9	(reserved)	The value at reading is undefined. Set "0" at writing.

(3) Details on the OMS bit of Statusword (pv mode)

Bit	Symbol	Description
10	Target reached	0 (Halt (Bit 8) = 0): Target velocity not reached. 0 (Halt (Bit 8) = 1): Axis decelerates 1 (Halt (Bit 8) = 0): Target velocity reached. 1 (Halt (Bit 8) = 1): Velocity of axis is 0 Judgment condition for Target velocity reached If the error between Velocity actual value (606Ch) and Target velocity (60FFh) has stayed within Velocity window (606Dh) for Velocity window time (606Eh) or more, Target velocity reached is stored.
12	Speed	0: Speed is not equal 0 1: Speed is equal 0 Judgment condition for Speed is not equal 0 If the absolute value of Velocity actual value (606Ch) has exceeded Velocity threshold (606Fh) for Velocity threshold time (6070h) or more, Speed is not equal 0 is stored.
13	Max slippage error	0: Maximum slippage not reached 1: Maximum slippage reached (not supported) (Note) Max slippage is a maximum slippage of the asynchronous servo motor.

No te. This is not supported by the driver.

(4) pv mode operation sequence

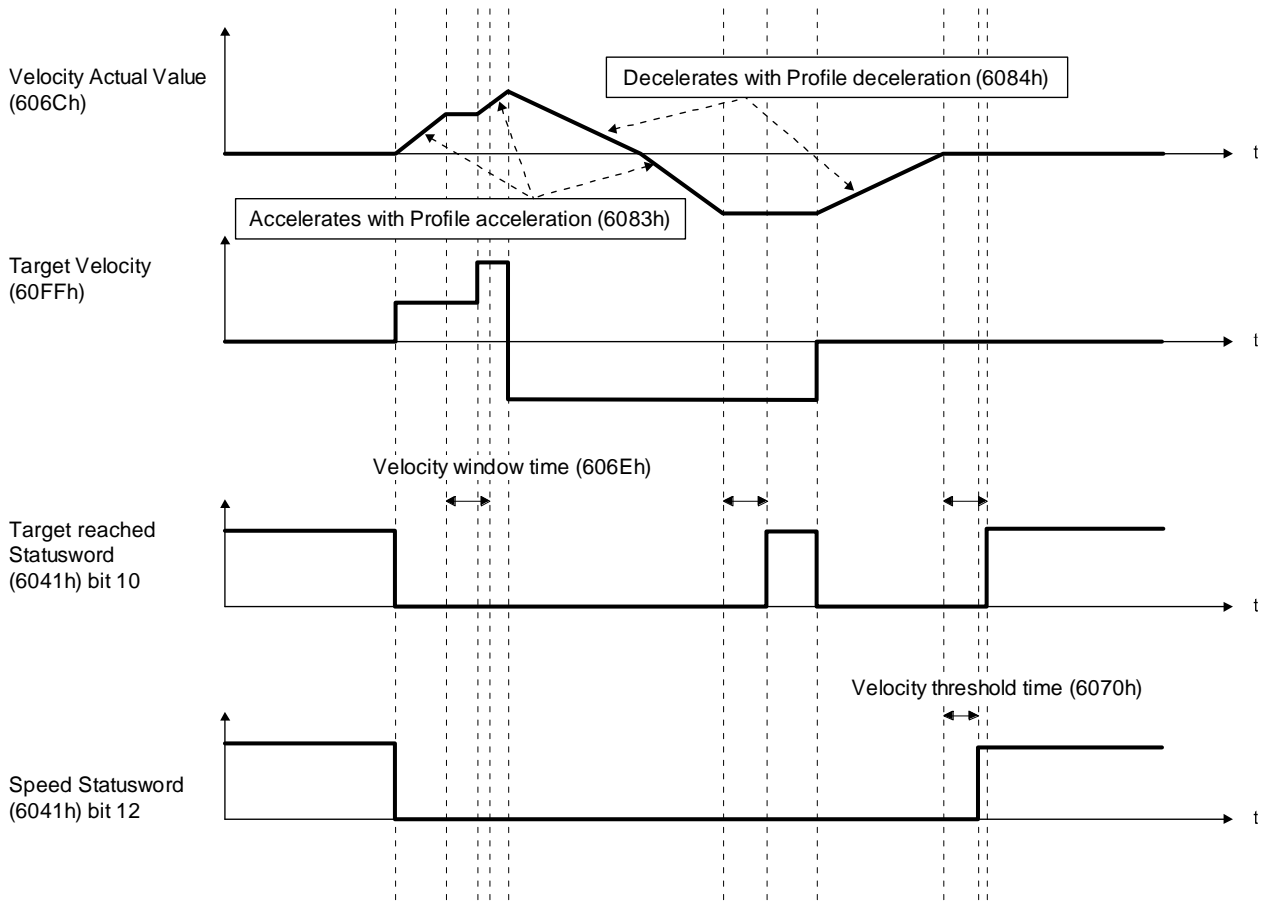

18.5.4.8 Profile torque mode (tq)

The following shows the functions and related objects of the profile torque mode (tq).

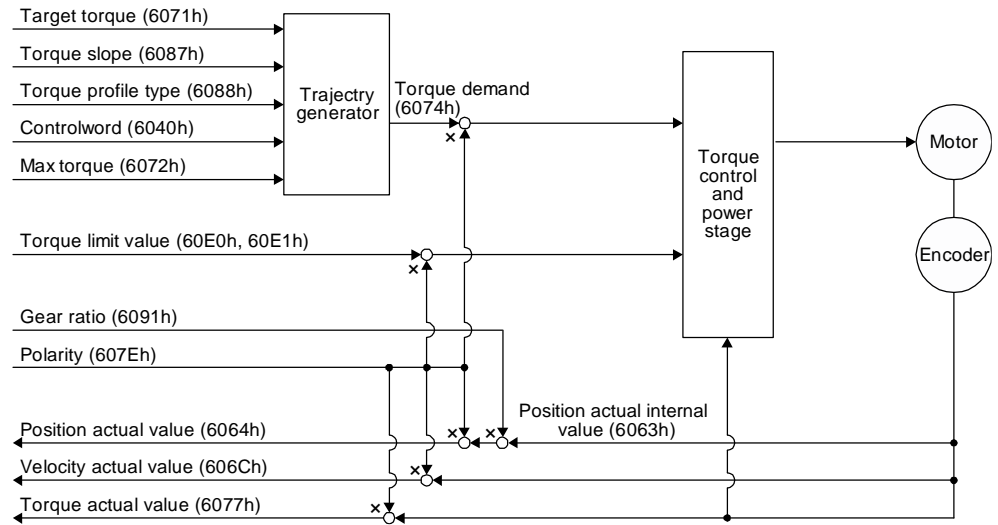

(1) Related object

Index	Sub	Object	Name	Data Type	Access	Default	Description
6040h		VAR	Controlword	U16	rw		Common control command
6071h		VAR	Target torque	I16	rw		Command torque Unit: 0.1% (rated torque of 100%)
6072h		VAR	Max torque	U16	rw		Maximum torque Unit: 0.1% (rated torque of 100%)
6074h		VAR	Torque demand	I16	ro		Command torque (after limit) Unit: 0.1% (rated torque of 100%)
6087h		VAR	Torque slope	U32	rw	0	Torque variation Unit: 0.1%/s (rated torque of 100%)
6088h		VAR	Torque profile type	U32	rw	0	Torque variation pattern 0000h: Linear ramp 0001h: Sin ² ramp (not supported) (Note 1) 0002h to 7FFFh: reserved 8000h to FFFFh: Manufacturer specific
6063h		VAR	Position actual internal value	I32	ro		Current position (Enc inc)
6064h		VAR	Position actual value	I32	ro		Current position (Pos units)
606Ch		VAR	Velocity actual value	I32	ro		Current speed Unit: Vel unit (0.01 r/min or 0.01 mm/s)
6077h		VAR	Torque actual value	I32	ro		Current torque Unit: 0.1% (rated torque of 100%)
6092h	0	ARRAY	Feed constant	U8	ro	2	Travel distance per revolution of an output shaft
	1		Feed	U32	rw	Travel distance Refer to section 7.3.14 (4).	
	2		Shaft revolutions			Number of servo motor shaft revolutions Refer to section 7.3.14 (4).	

18. EtherCAT COMMUNICATION

Index	Sub	Object	Name	Data Type	Access	Default	Description
60E0h		VAR	Positive torque limit value	U16	rw	10000	Torque limit value (forward) Unit: 0.1% (rated torque of 100%)
60E1h		VAR	Negative torque limit value	U16	rw	10000	Torque limit value (reverse) Unit: 0.1% (rated torque of 100%)
6091h	0	ARRAY	Gear ratio	U8	ro	2	Gear ratio
	1		Motor revolutions	U32	rw	1	Number of revolutions of the servo motor axis (numerator)
	2		Shaft revolutions			1	Number of revolutions of the drive axis (denominator)
607Eh		VAR	Polarity	U8	rw	0	Polarity selection Bit 7: Position POL Bit 6: Velocity POL Bit 5: Torque POL (Note 2) Refer to section 5.10.
2D20h		VAR	Velocity limit value	I32	rw	5000	Speed limit value Unit: Vel unit (0.01 r/min or 0.01 mm/s)
60A8h		VAR	SI unit position	U32	rw	0	SI unit position The value is automatically set according to the setting of "Position data unit" of [Pr. PT01]. Refer to section 7.3.14 (5).
60A9h		VAR	SI unit velocity	U32	rw	0	SI unit velocity 0.01 r/min or 0.01 mm/s FB010300h (0.01 mm/s) FEB44700h (0.01 r/min)

Note 1. This is not supported by the driver.

(2) Details on the OMS bit of Controlword (tq mode)

Bit	Symbol	Description
4	(reserved)	The value at reading is undefined. Set "0" at writing.
5	(reserved)	
6	(reserved)	
8	HALT	0: The servo motor is driven. 1: The servo motor is stopped according to Halt option code (605Dh).
9	(reserved)	The value at reading is undefined.

(3) Details on the OMS bit of Statusword (tq mode)

Bit	Symbol	Description
10	Target reached (not supported) (Note)	0 (Halt (Bit 8) = 0): Target torque not reached. 0 (Halt (Bit 8) = 1): Axis decelerates 1 (Halt (Bit 8) = 0): Target torque reached. 1 (Halt (Bit 8) = 1): Velocity of axis is 0 Judgment condition for Target torque reached If the error between Torque actual value (6077h) and Target torque (6071h) has stayed within Torque window for Torque window time or more, Target torque reached is stored.
12	(reserved)	The value at reading is undefined.
13	(reserved)	

Note This is not supported by the driver.

(4) tq mode operation sequence

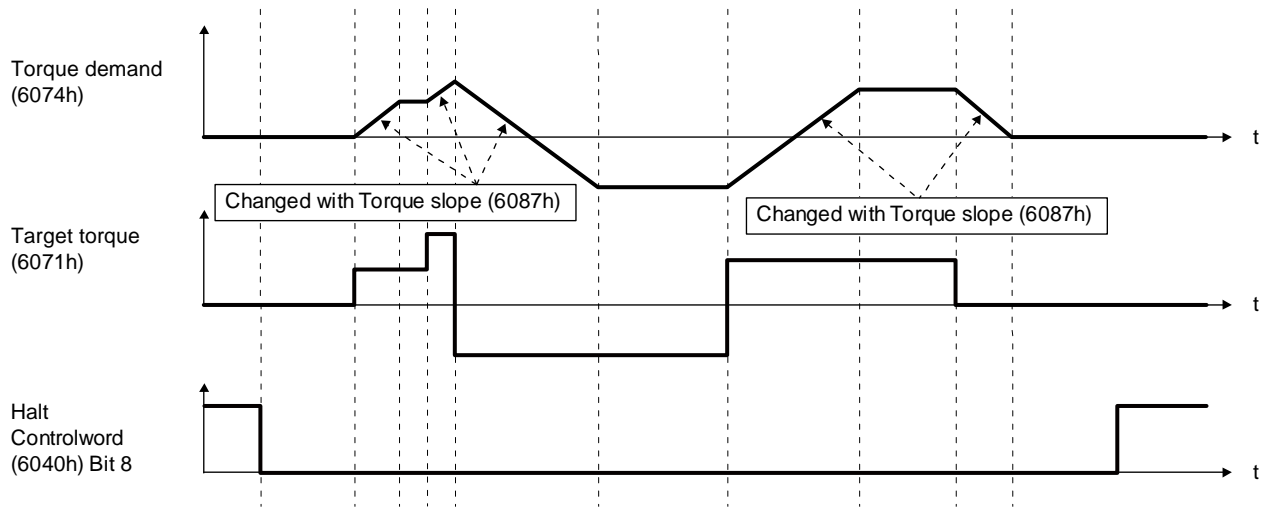

18. EtherCAT COMMUNICATION

18.5.4.9 Homing mode (hm)

The following shows the function and related objects of the homing mode (hm).

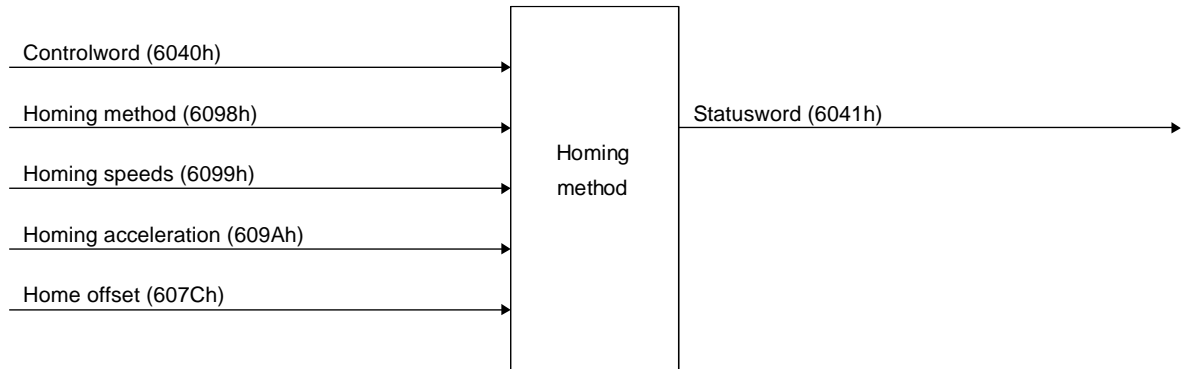

(1) Related object

Index	Sub	Object	Name	Data Type	Access	Default	Description
607Ch	0	VAR	Home offset	I32	ro		The home position saved in EEPROM is stored at power-on. If a home position return is executed in the homing mode (hm), the home position will be updated. If [Pr. PA03 Absolute position detection system] is disabled, 0 is always stored.
6098h	0	VAR	Homing Method	I8	rw	-1	Specify a home position return type. Refer to (4) in this section for supported home position return types.
6099h	0	ARRAY	Homing Speeds	U8	rw	2	Number of entries of the home position return speed
	1		Speed during search for switch	U32	rw	10000	Specify the travel speed until dog detection. Unit: Vel unit (0.01 r/min or 0.01 mm/s) Range: 0 to servo motor maximum speed
	2		Speed during search for zero	U32	rw	1000	Specify the travel speed up to the home position after dog detection. (Note) Unit: Vel unit (0.01 r/min or 0.01 mm/s) Range: 0 to servo motor maximum speed
609Ah	0	VAR	Homing acceleration	U32	rw	0	Acceleration/deceleration time constant at home position return Unit: ms
60E3h	0	ARRAY	Supported Homing Method	U8	ro	39	Number of entries of the supported home position return type
	1		1 st supported homing method	I8	ro	Refer to section 7.3.13 (5).	The supported home position return type is returned.
	39		39 th supported homing method	I8	ro	Refer to section 7.3.13 (5).	The supported home position return type is returned.

Note: In the homing mode (hm), the servo motor is brought to a sudden stop according to the deceleration time constant when the stroke end is detected. Set the home position return speed carefully.

18. EtherCAT COMMUNICATION

(2) Details on the OMS bit of Controlword (hm mode)

Bit	Symbol	Description
4	HOS	Homing operation start 0: Do not start homing procedure 1: Start or continue homing procedure
5	(reserved)	The value at reading is undefined. Set "0" at writing.
6	(reserved)	
8	HALT	Halt 0: Bit 4 enable 1: Stop axis according to halt option code (605Dh) In the indexer method, this bit is disabled.
9	(reserved)	The value at reading is undefined. Set "0" at writing.

(3) Details on the OMS bit of Statusword (hm mode)

POINT
<ul style="list-style-type: none"> ● When the mode is switched to the hm mode after home position return completion, Statusword is "Homing procedure is completed successfully" unless "0" is set in Bit 12. The following shows the conditions when "0" is set in Bit 12. For incremental system <ul style="list-style-type: none"> · At power-on · At communication shut-off by upper side reset · At home position return start · At home position erasure For absolute position detection system <ul style="list-style-type: none"> · At home position return start · At home position erasure ● To check the home position return status with Statusword, note the following. (when the communication cycle of 4 ms or less is set) <ul style="list-style-type: none"> · When the mode is switched to the hm mode, Modes of operation display is changed to 6 (hm) and Statusword changes at the same time. · The status change of Statusword may take 50 ms at a maximum after Bit 4 of Controlword (Homing operation start) is set. To obtain the status of Statusword without any fault, wait 50 ms or more. ● Before updating the position after a home position return completion, check that both Bit 12 and Bit 10 of Statusword are changed to "1" and then wait 8 ms. If 8 ms has not elapsed, the position information may not be updated correctly depending on the communication cycle setting.

Bit	Symbol	Description
10	Target reached	Refer to the following table for the definition.
12	Homing attained	
13	Homing error	

The following shows the definition of Bit 10, Bit 12, and Bit 13 of Statusword in the hm mode.

Bit 13	Bit 12	Bit 10	Definition
0	0	0	Homing procedure is in progress
0	0	1	Homing procedure is interrupted or not started
0	1	0	Homing is attained, but target is not reached
0	1	1	Homing procedure is completed successfully
1	0	0	Homing error occurred, velocity is not 0
1	0	1	Homing error occurred, velocity is 0
1	1		reserved

(4) List of Homing method

POINT
<ul style="list-style-type: none"> ● In the following cases, make sure that the Z-phase has been passed through once before the home position return. Z-phase unpassed will trigger [AL. 90.5 Z-phase unpassed]. <ul style="list-style-type: none"> ▫ When using an incremental external encoder in the fully closed loop control mode ▫ For the use in the DD motor control mode ● To execute a home position return securely, start a home position return after moving the servo motor to the opposite stroke end with csv or pv from the upper side and others. Whether the servo motor has reached the stroke end can be checked with Digital inputs (60FDh). ● When changing the mode after the home position return completion, set 0 to the Target position (607Ah) and change the control mode. ● The Method numbers which can be used in indexer method are only -1, -33, -3, 35 and 37.

18. EtherCAT COMMUNICATION

To specify the home position return type in the homing mode (hm), use Homing Method (6098h). The driver supports Homing method in the following table.

Method No.	Home position return type	Rotation direction	Description
-1	Dog type (Rear end detection Z-phase reference)/ torque limit changing dog type (Front end detection Z-phase reference)	Forward rotation	Deceleration starts at the front end of the proximity dog. After the rear end is passed, the position specified by the first Z-phase signal, or the position of the first Z-phase signal shifted by the specified home position shift distance is used as the home position. In the indexer method, deceleration starts at the front end of the proximity dog, and then the first Z-phase signal at which a deceleration to a stop is possible or the position of the Z-phase signal shifted by the specified home position shift distance is used as the home position. The torque limit values in Positive torque limit value (60E0h) and Negative torque limit value (60E1h) are enabled during execution of home position return, and the torque limit value in Torque limit value2 (2D6Bh) is enabled when the home position return is stopped.
-33		Reverse rotation	
-3	Data set type home position return/ torque limit changing data set type		The current position is set as the home position. In the indexer method, the current position is set as the home position. The torque limit value becomes 0 when switched to the homing mode (hm).
-4	Stopper type (Stopper position reference)	Forward rotation	A workpiece is pressed against a mechanical stopper, and the position where it is stopped is set as the home position.
-36		Reverse rotation	
-2	Count type (Front end detection Z-phase reference)	Forward rotation	At the front end of the proximity dog, deceleration starts. After the front end is passed, the position specified by the first Z-phase signal after the set distance or the position of the Z-phase signal shifted by the set home position shift distance is set as a home position.
-34		Reverse rotation	
-6	Dog type (Rear end detection rear end reference)	Forward rotation	Deceleration starts from the front end of the proximity dog. After the rear end is passed, the position is shifted by the travel distance after proximity dog and the home position shift distance. The position after the shifts is set as the home position.
-38		Reverse rotation	
-7	Count type (Front end detection front end reference)	Forward rotation	Deceleration starts from the front end of the proximity dog. The position is shifted by the travel distance after proximity dog and the home position shift distance. The position after the shifts is set as the home position.
-39		Reverse rotation	
-8	Dog cradle type	Forward rotation	A position, which is specified by the first Z-phase signal after the front end of the proximity dog is detected, is set as the home position.
-40		Reverse rotation	
-9	Dog type last Z-phase reference	Forward rotation	After the front end of the proximity dog is detected, the position is shifted away from the proximity dog in the reverse direction. Then, the position specified by the first Z-phase signal or the position of the first Z-phase signal shifted by the home position shift distance is used as the home position.
-41		Reverse rotation	
-10	Dog type front end reference	Forward rotation	Starting from the front end of the proximity dog, the position is shifted by the travel distance after proximity dog and the home position shift distance. The position after the shifts is set as the home position.
-42		Reverse rotation	
-11	Dogless Z-phase reference	Forward rotation	The position specified by the first Z-phase signal, or the position of the first Z-phase signal shifted by the home position shift distance is used as the home position.
-43		Reverse rotation	
0	No homing method assigned		Home position return cannot be performed. Starting home position return causes "Homing error".
3	Homing on positive home switch and index pulse	Forward rotation	Same as the dog type last Z-phase reference home position return. Note that if the stroke end is detected during home position return, [AL. 90 Home position return incomplete warning] occurs.

18. EtherCAT COMMUNICATION

4	Homing on positive home switch and index pulse	Forward rotation	Same as the dog cradle type home position return. Note that if the stroke end is detected during home position return, [AL. 90 Home position return incomplete warning] occurs.
5	Homing on negative home switch and index pulse	Reverse rotation	Same as the dog type last Z-phase reference home position return. Note that if the stroke end is detected during home position return, [AL. 90 Home position return incomplete warning] occurs.

Method No.	Home position return type	Rotation direction	Description
6	Homing on negative home switch and index pulse	Reverse rotation	Same as the dog cradle type home position return. Note that if the stroke end is detected during home position return, [AL. 90 Home position return incomplete warning] occurs.
7	Homing on home switch and index pulse	Forward rotation	Same as the dog type last Z-phase reference home position return.
8	Homing on home switch and index pulse	Forward rotation	Same as the dog cradle type home position return.
11	Homing on home switch and index pulse	Reverse rotation	Same as the dog type last Z-phase reference home position return.
12	Homing on home switch and index pulse	Reverse rotation	Same as the dog cradle type home position return.
19	Homing without index pulse	Forward rotation	Same as the dog type front end reference home position return. Note that if the stroke end is detected during home position return, [AL. 90 Home position return incomplete warning] occurs.
20	Homing without index pulse	Forward rotation	Although this type is the same as the dog cradle type home position return, the stop position is not on the Z-phase. Starting from the front end of the dog, the position is shifted by the travel distance after proximity dog and the home position shift distance. The position after the shifts is set as the home position. If the stroke end is detected during home position return, [AL. 90 Home position return incomplete warning] occurs.
21	Homing without index pulse	Reverse rotation	Same as the dog type front end reference home position return. Note that if the stroke end is detected during home position return, [AL. 90 Home position return incomplete warning] occurs.
22	Homing without index pulse	Reverse rotation	Although this type is the same as the dog cradle type home position return, the stop position is not on the Z-phase. Starting from the front end of the dog, the position is shifted by the travel distance after proximity dog and the home position shift distance. The position after the shifts is set as the home position. If the stroke end is detected during home position return, [AL. 90 Home position return incomplete warning] occurs.
23	Homing without index pulse	Forward rotation	Same as the dog type front end reference home position return.
24	Homing without index pulse	Forward rotation	Although this type is the same as the dog cradle type home position return, the stop position is not on the Z-phase. Starting from the front end of the dog, the position is shifted by the travel distance after proximity dog and the home position shift distance. The position after the shifts is set as the home position.
27	Homing without index pulse	Reverse rotation	Same as the dog type front end reference home position return.
28	Homing without index pulse	Reverse rotation	Although this type is the same as the dog cradle type home position return, the stop position is not on the Z-phase. Starting from the front end of the dog, the position is shifted by the travel distance after proximity dog and the home position shift distance. The position after the shifts is set as the home position.
33	Homing on index pulse	Reverse rotation	Although this type is the same as the dogless Z-phase reference home position return, the creep speed is applied as the movement start speed.
34	Homing on index pulse	Forward rotation	Although this type is the same as the dogless Z-phase reference home position return, the creep speed is applied as the movement start speed.
35	Homing on current position		The current position is set as the home position. This type can be executed not in the Operation enabled state.
37	Homing on current position		The current position is set as the home position. This type can be executed not in the Operation enabled state.

(5) CiA 402-type homing method

(a) Home position return type in CiA 402 type

The following shows the CiA 402-type home position return.

1) Method 3 and 4: Homing on positive home switch and index pulse

These home position return types use the front end of the proximity dog as reference and set the Z-phase right before and right after the dog as a home position.

Method 3 has the operation of the dog type last Z-phase reference home position return, and

Method 4 has the operation of the dog cradle type home position return at a forward rotation start.

However, if the stroke end is detected during home position return, [AL. 90] occurs.

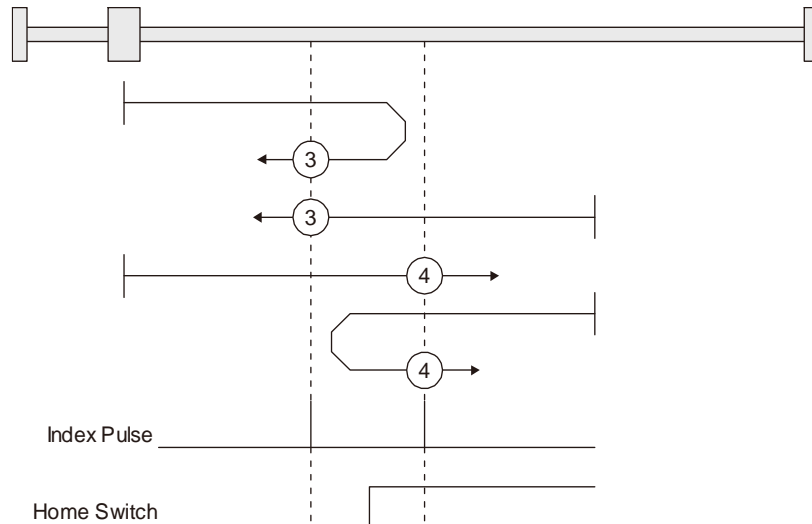

2) Method 5 and 6: Homing on negative home switch and index pulse

These home position return types use the front end of the proximity dog as reference and set the Z-phase right before and right after the dog as a home position. Method 5 and 6 differ from Method 3 and Method 4 in the starting direction: the starting direction of Method 5 and 6 is the reversed direction.

3) Method 7, 8, 11, 12: Homing on home switch and index pulse

These types include the operation at stroke end detection in addition to the operation of Method 3 to Method 6. Thus, the home position is the same as that of Method 3 to Method 6. Method 7 has the operation of the dog type last Z-phase reference home position return. Method 8 has the operation of the dog cradle type home position return at a forward rotation start. Method 11 and 12 differ from Method 7 and Method 8 only in the starting direction: the starting direction of Method 11 and 12 is the reversed direction.

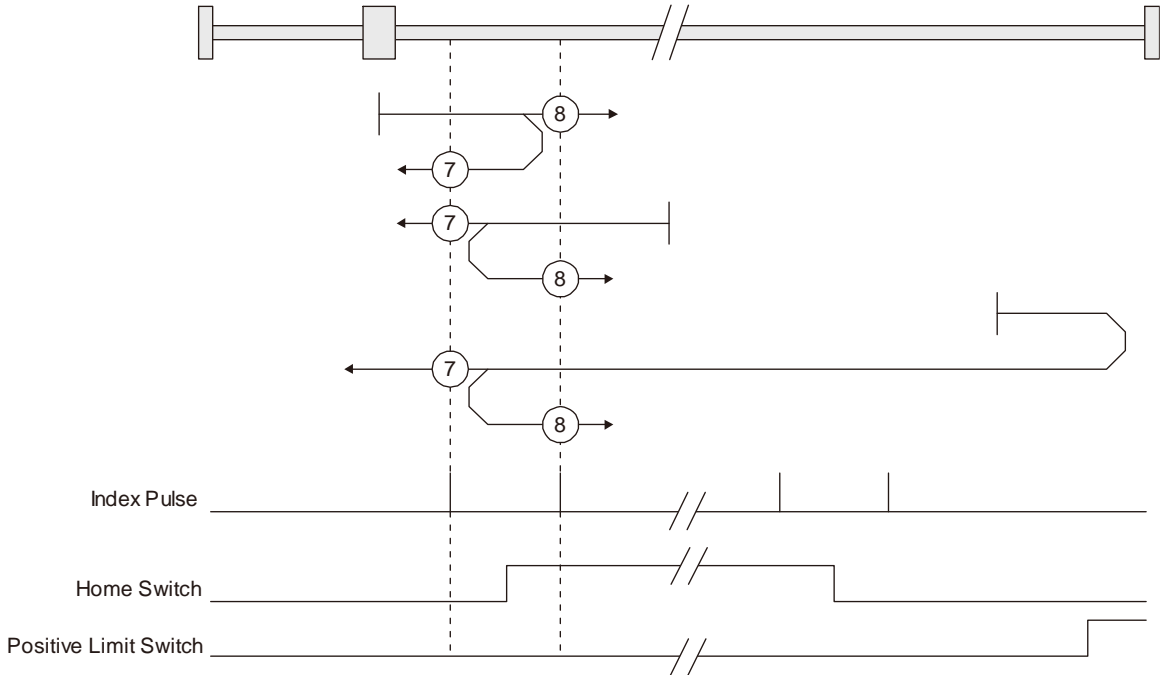

4) Method 17 to 30: Homing without index pulse

Method 17 to 30 have the operation of Method 1 to Method 14; however, these types set the home position not on the Z-phase but on the dog. Method 17 to 30 have the operation of Method 1 to Method 14; however, these types set the home position not on the Z-phase but on the dog. The following figure shows the operation of the home position return type of Method 19 and Method 20. Method 19 and Method 20 have the operation of Method 3 and Method 4; however, these types set the home position not on the Z-phase but on the dog Method 19 has the operation of the dog type front end reference home position return. Method 20 has the operation of the dog cradle type home position return; however, the stop position is not on the Z-phase but on the dog.

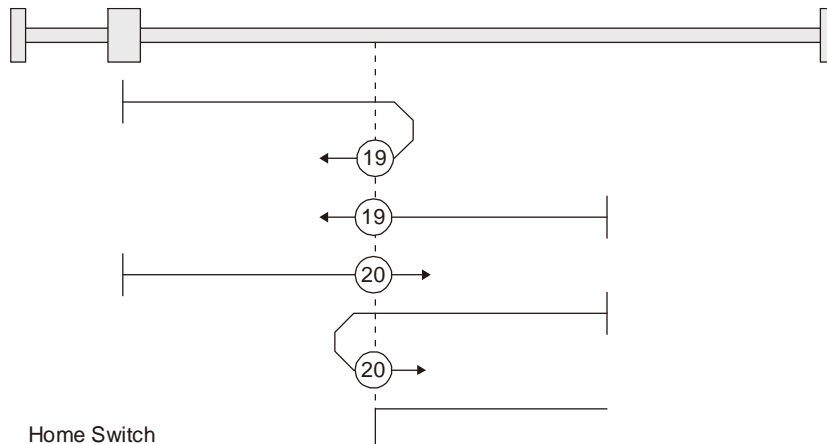

5) Method 33 and 34: Homing on index pulse

These home position return types set the Z-phase detected first as a home position. The operation is the same as that of the dogless Z-phase reference home position return except that the creep speed is applied at the start.

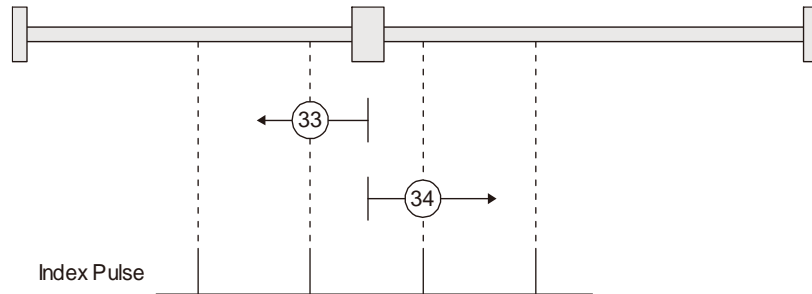

6) Method 35 and 37: Homing on current position

These home position return types set the current position as a home position. The operation is the same as that of the data set type home position return; however, these types can be executed even during servo-off.

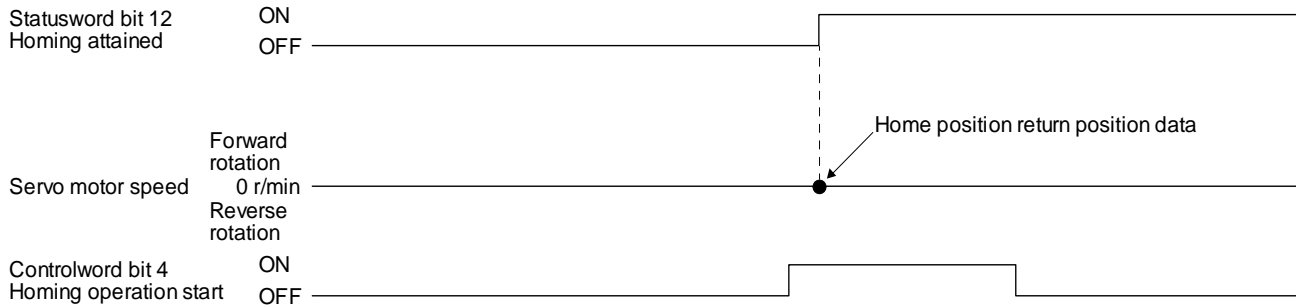

(b) Operation example of the CiA 402-type Homing method

The following shows an operation example of the home position return in the CiA 402-type Homing method.

- 1) Method 3 (Homing on positive home switch and index pulse) and Method 5 (Homing on negative home switch and index pulse)

The following figure shows the operation of Homing method 3. The operation direction of Homing method 5 is opposite to that of Homing method 3.

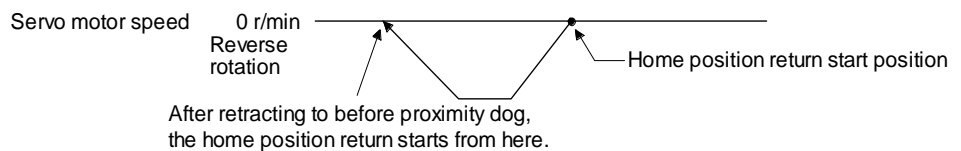
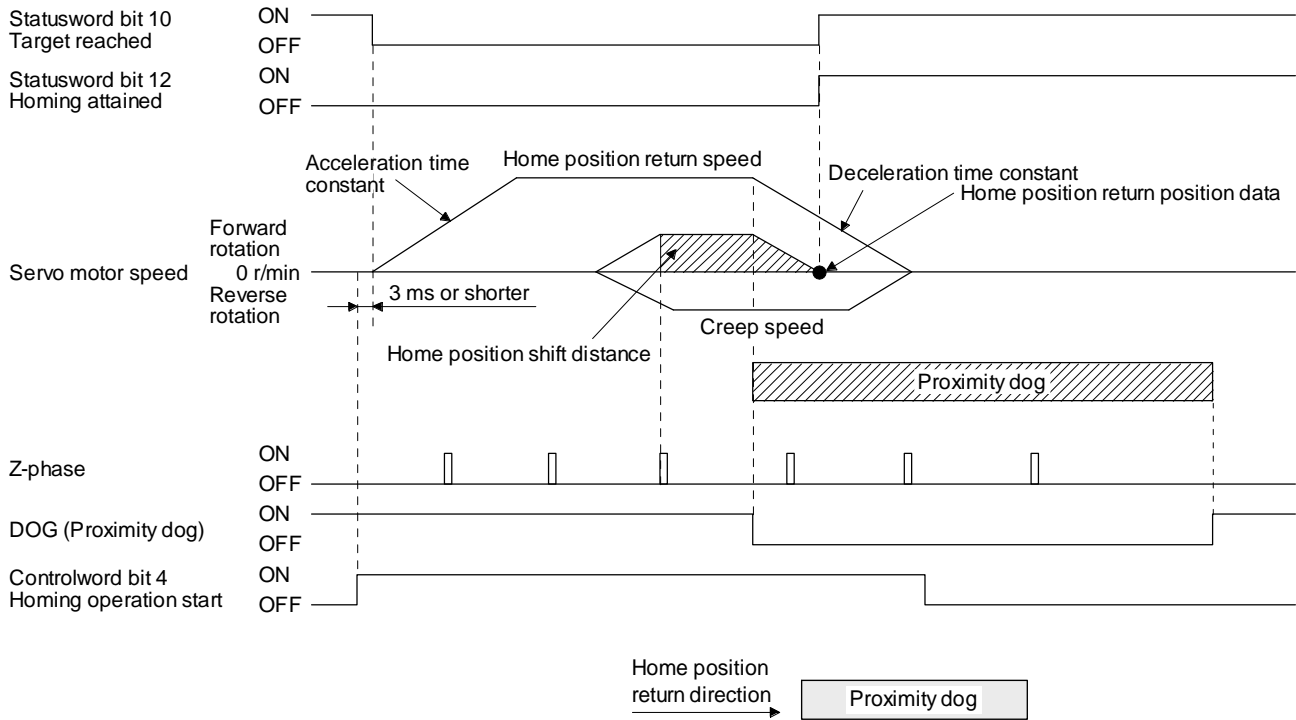

When a home position return is started from the proximity dog

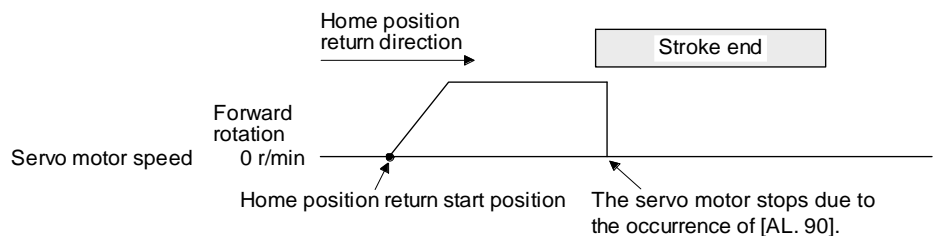

When the stroke end is detected

- 2) Method 4 (Homing on positive home switch and index pulse) and Method 6 (Homing on negative home switch and index pulse)

The following figure shows the operation of Homing method 4. The operation direction of Homing method 6 is opposite to that of Homing method 4.

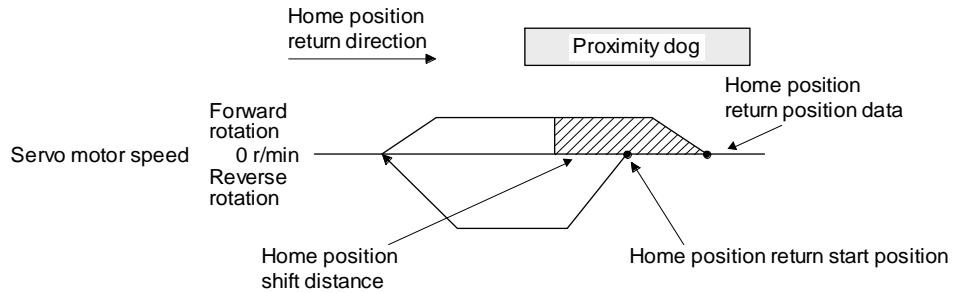
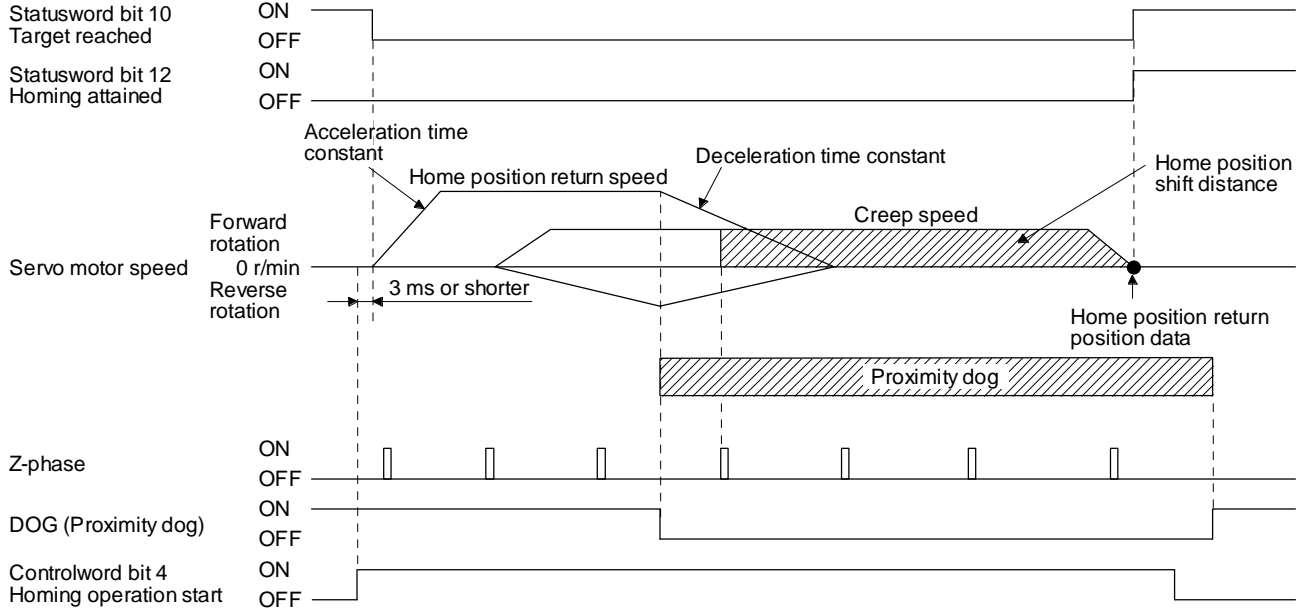

When a home position return is started from the proximity dog

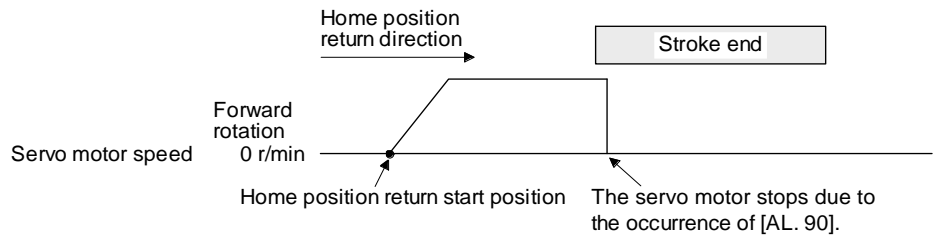

When the stroke end is detected

3) Method 7 and Method 11 (Homing on home switch and index pulse)

The following figure shows the operation of Homing method 7. The operation direction of Homing method 11 is opposite to that of Homing method 7.

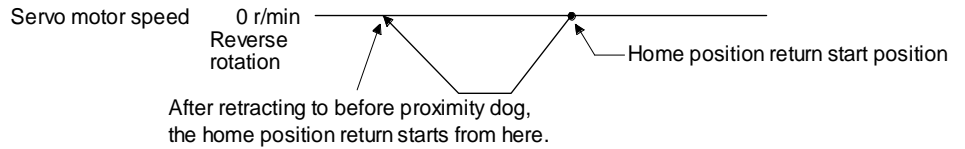
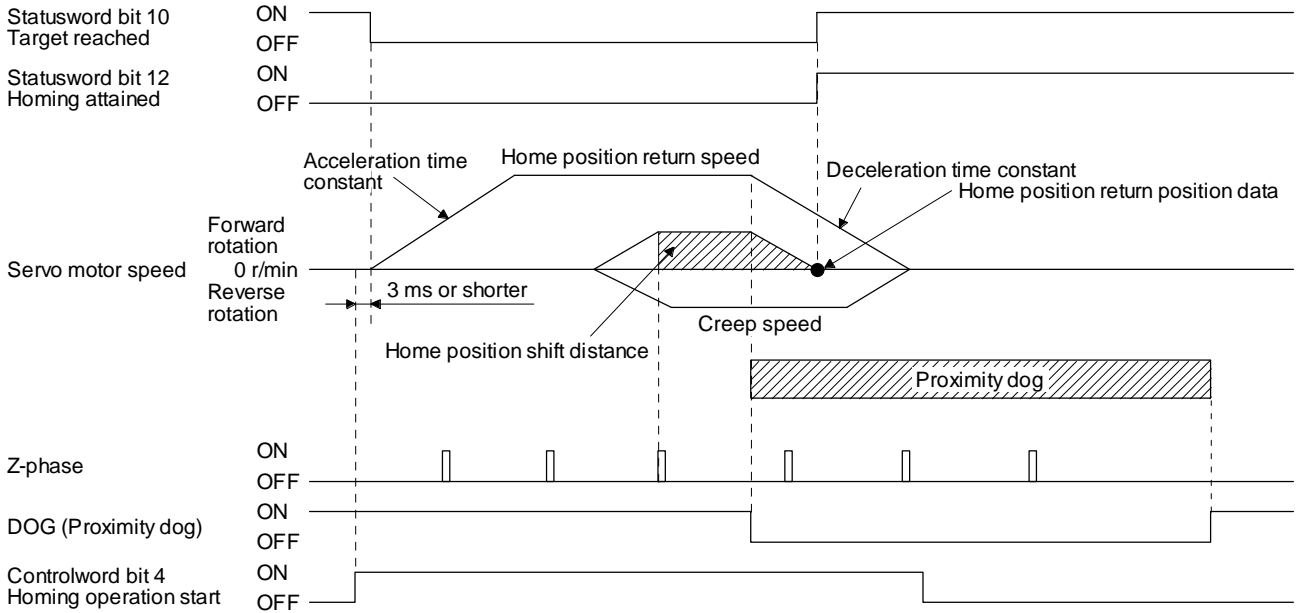

When a home position return is started from the proximity dog

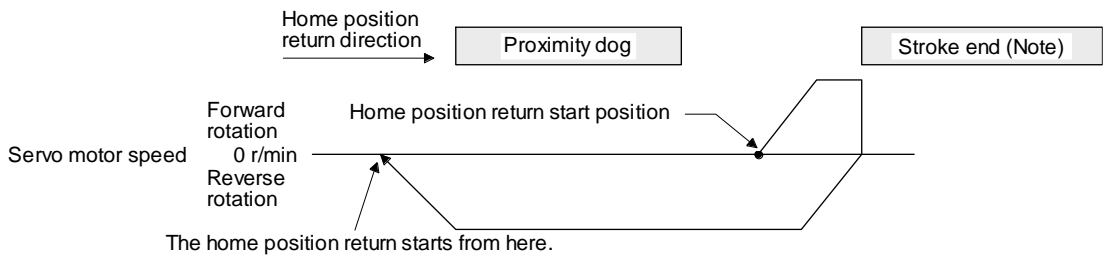

No	The software limit cannot be used with these functions.
----	---

When the movement is returned at the stroke end

4) Method 8 and Method 12 (Homing on home switch and index pulse)

The following figure shows the operation of Homing method 8. The operation direction of Homing method 12 is opposite to that of Homing method 8.

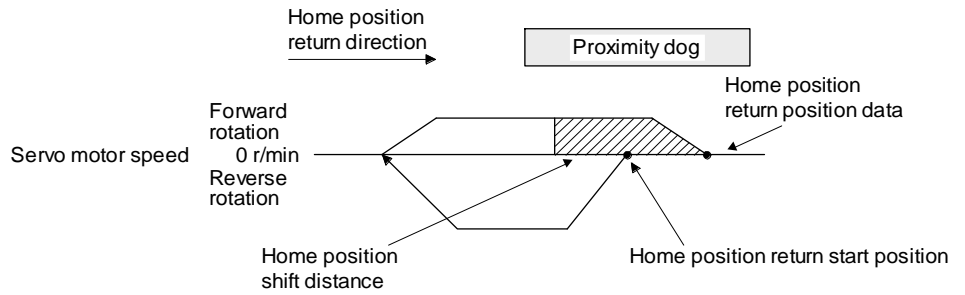
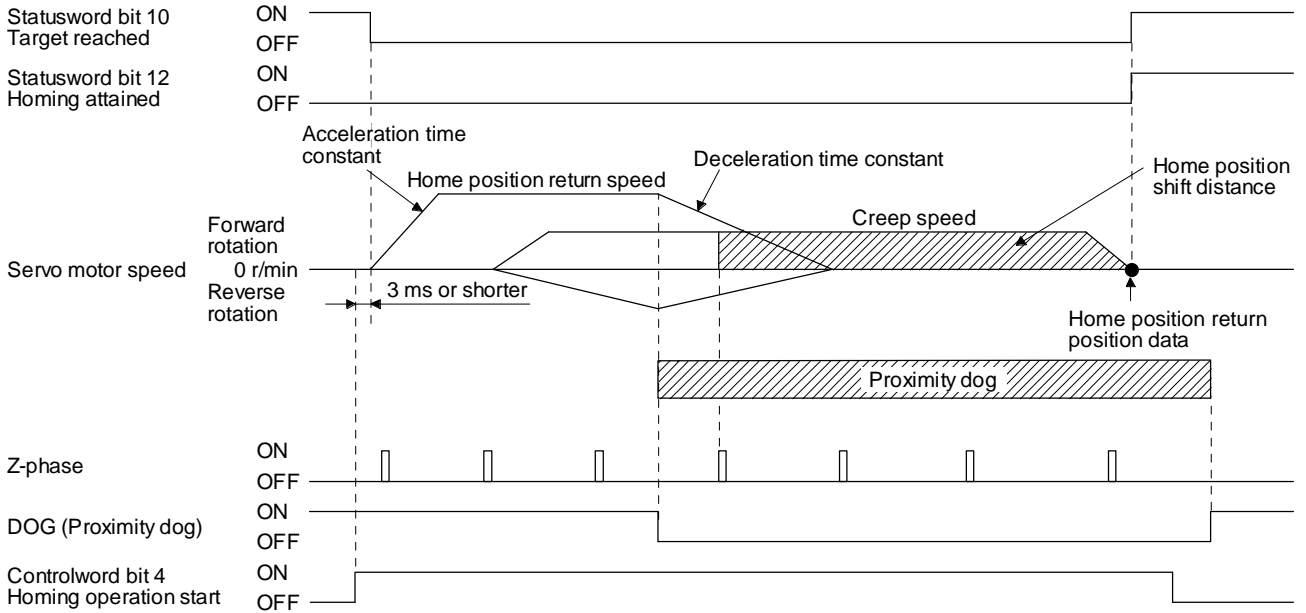

When a home position return is started from the proximity dog

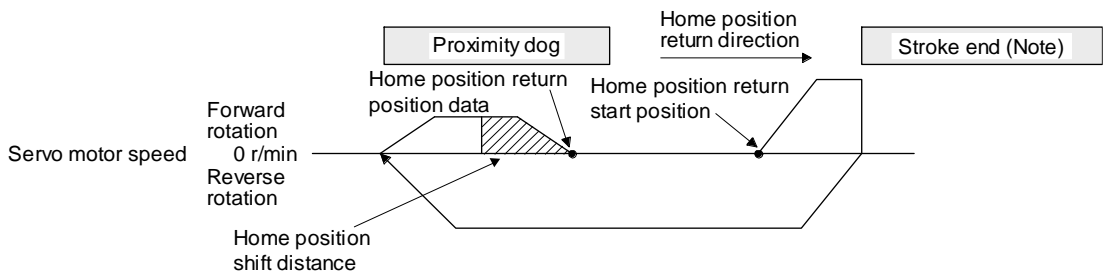

No	The software limit cannot be used with these functions.
te.	

When the movement is returned at the stroke end

5) Method 19 and Method 21 (Homing without index pulse)

The following figure shows the operation of Homing method 19. The operation direction of Homing method 21 is opposite to that of Homing method 19.

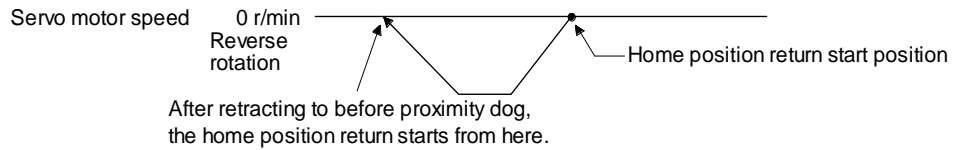
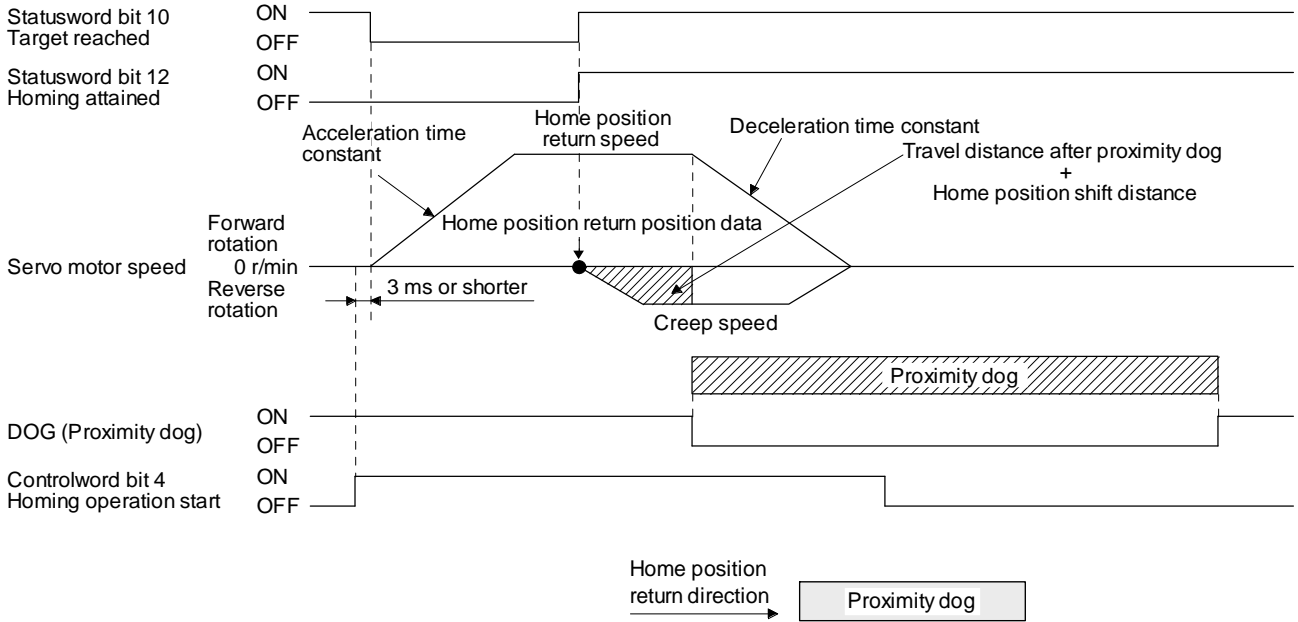

When a home position return is started from the proximity dog

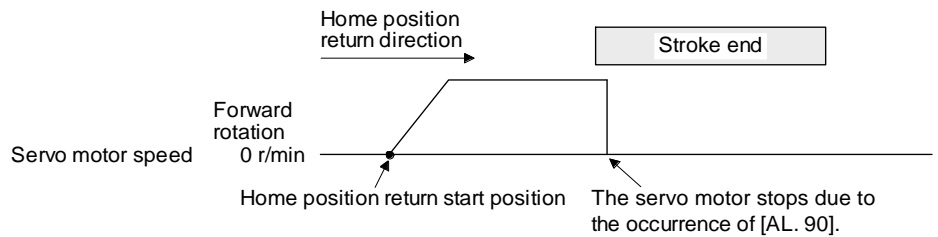

When the stroke end is detected

6) Method 20 and Method 22 (Homing without index pulse)

The following figure shows the operation of Homing method 20. The operation direction of Homing method 22 is opposite to that of Homing method 20.

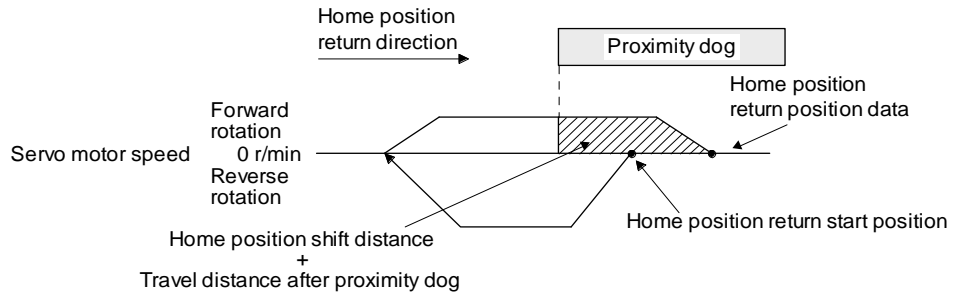
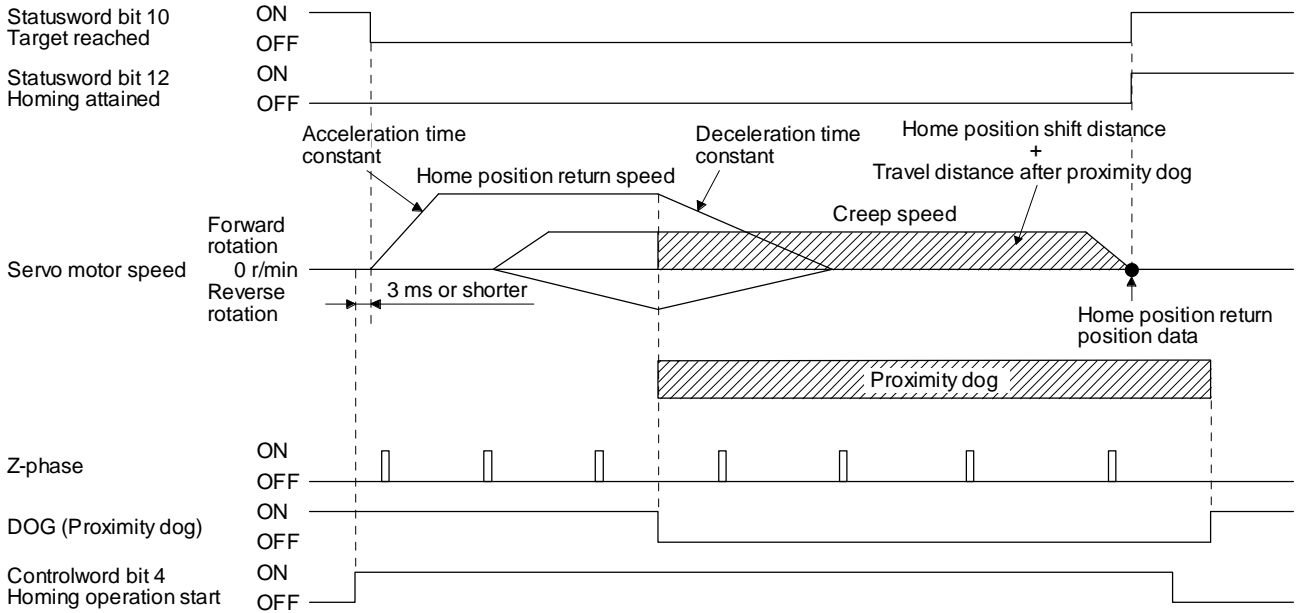

When a home position return is started from the proximity dog

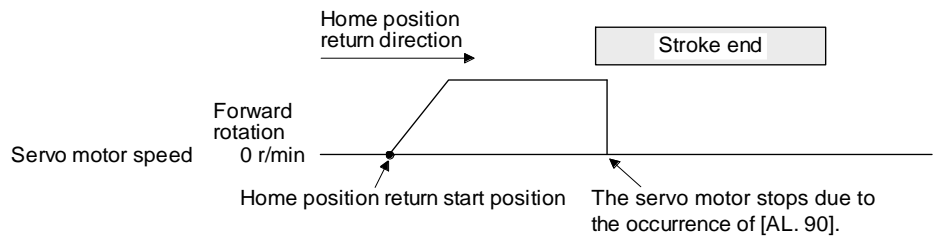

When the stroke end is detected

7) Method 23 and Method 27 (Homing without index pulse)

The following figure shows the operation of Homing method 23. The operation direction of Homing method 27 is opposite to that of Homing method 23.

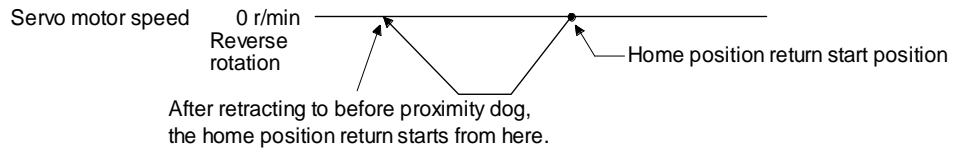
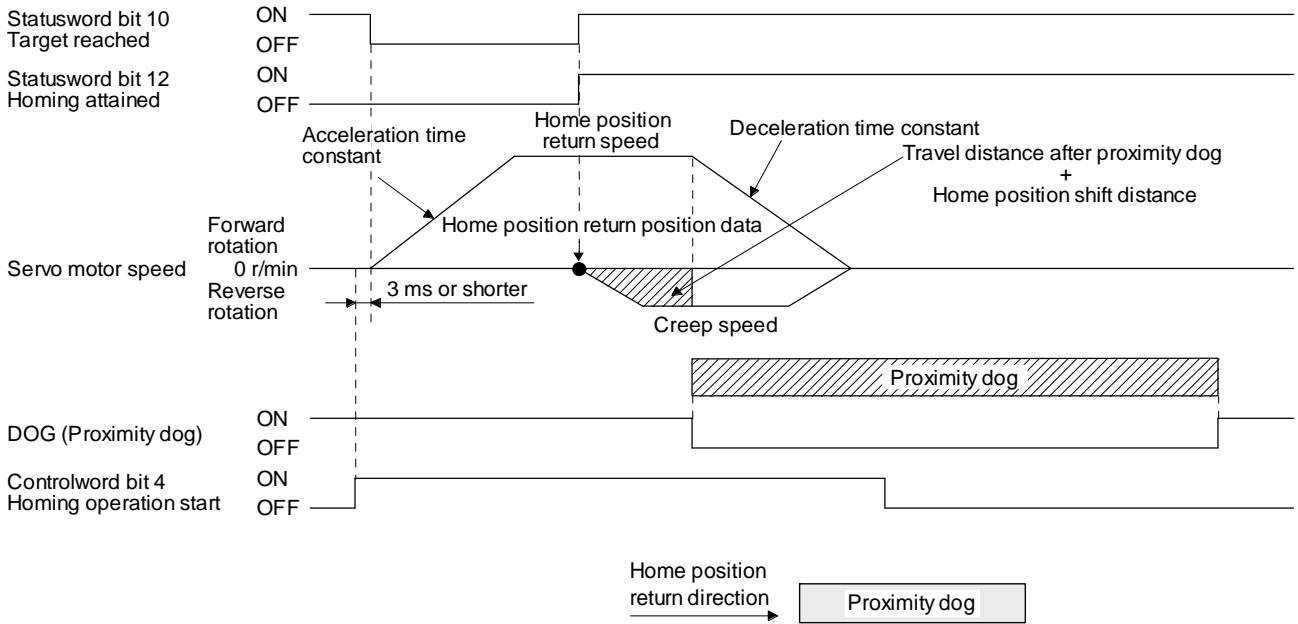

When a home position return is started from the proximity dog

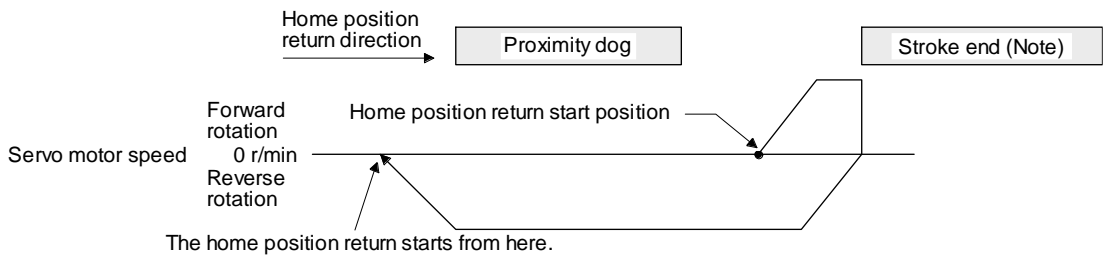

No te.	The software limit cannot be used with these functions.
--------	---

When the movement is returned at the stroke end

8) Method 24 and Method 28 (Homing without index pulse)

The following figure shows the operation of Homing method 24. The operation direction of Homing method 28 is opposite to that of Homing method 24.

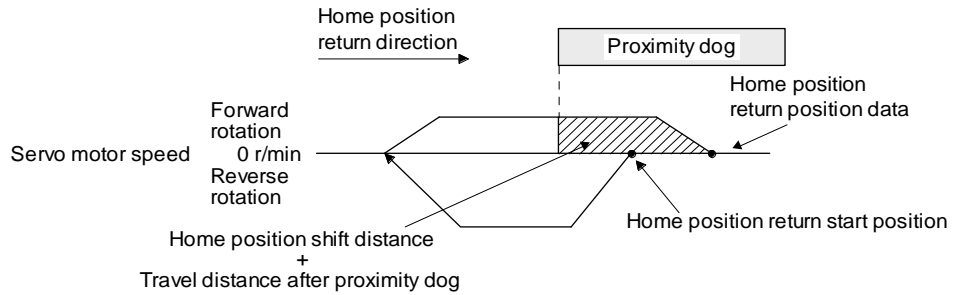
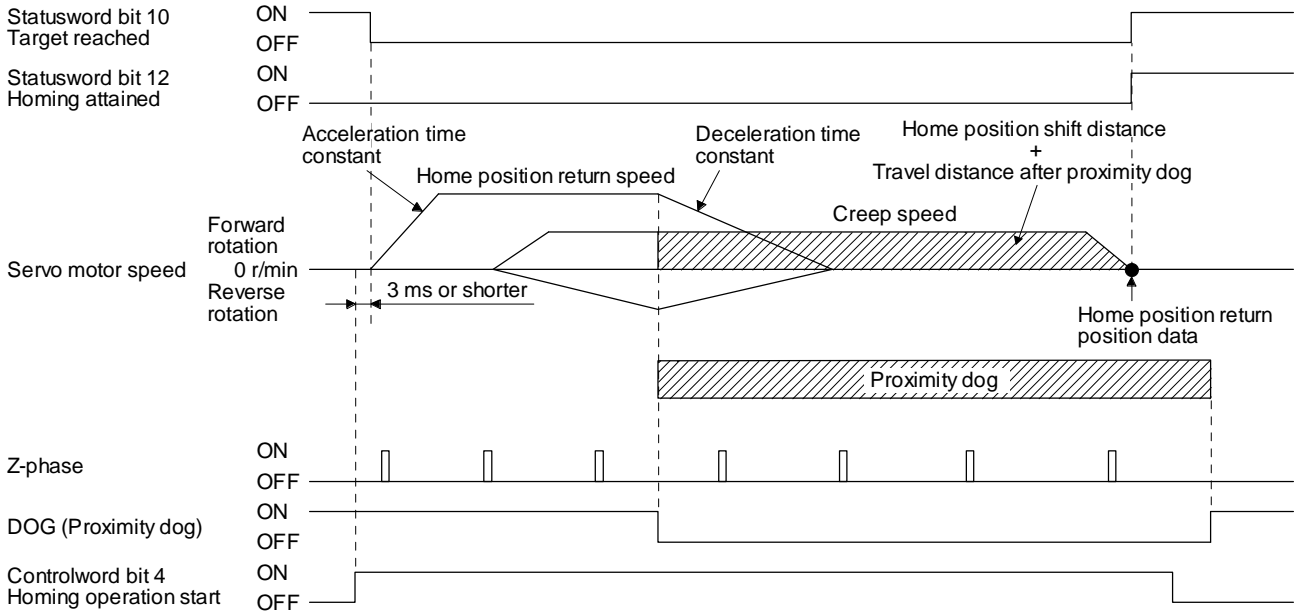

When a home position return is started from the proximity dog

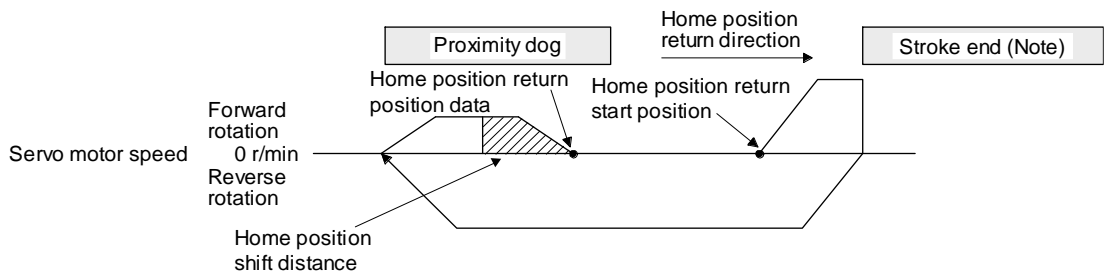

No te.	The software limit cannot be used with these functions.
--------	---

When the movement is returned at the stroke end

9) Method 33 and Method 34 (Homing on index pulse)

The following figure shows the operation of Homing method 34. The operation direction of Homing method 33 is opposite to that of Homing method 34.

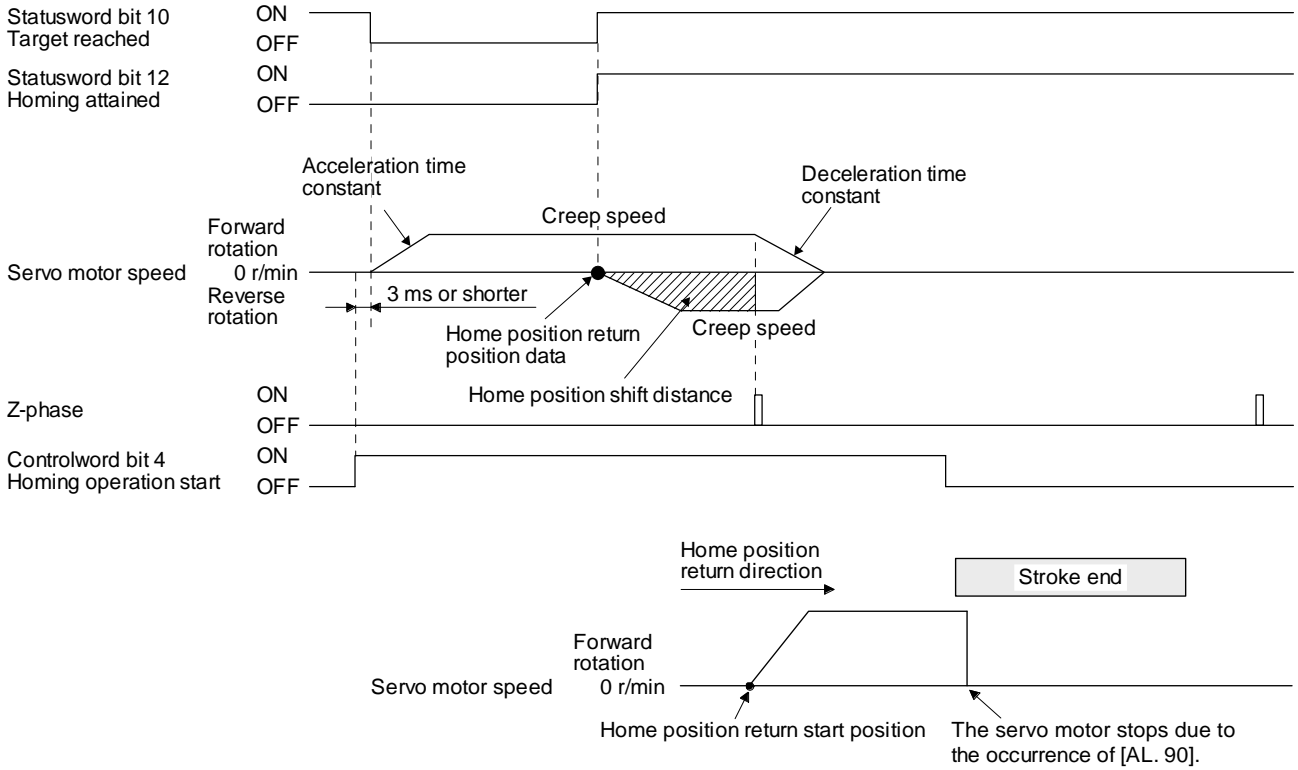

When the stroke end is detected

10) Method 35 and Method 37 (Homing on current position)

The following figure shows the operation of Homing method 35 and Homing method 37. These methods can be performed in the servo-off status.

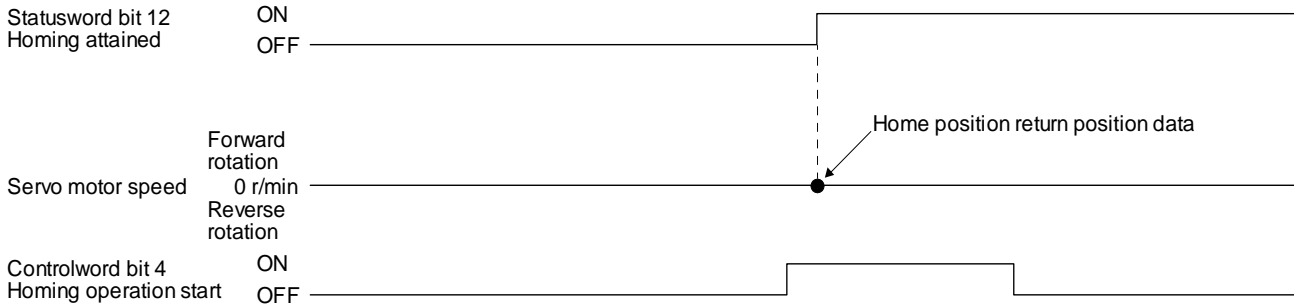

(6) Operation example of Manufacturer-specific Homing method

The following shows an operation example of the Manufacturer-specific home return.

(a) Method -1 and -33

1) Dog type home position return

The following figure shows the operation of Homing method -1. The operation direction of Homing method -33 is opposite to that of Homing method -1.

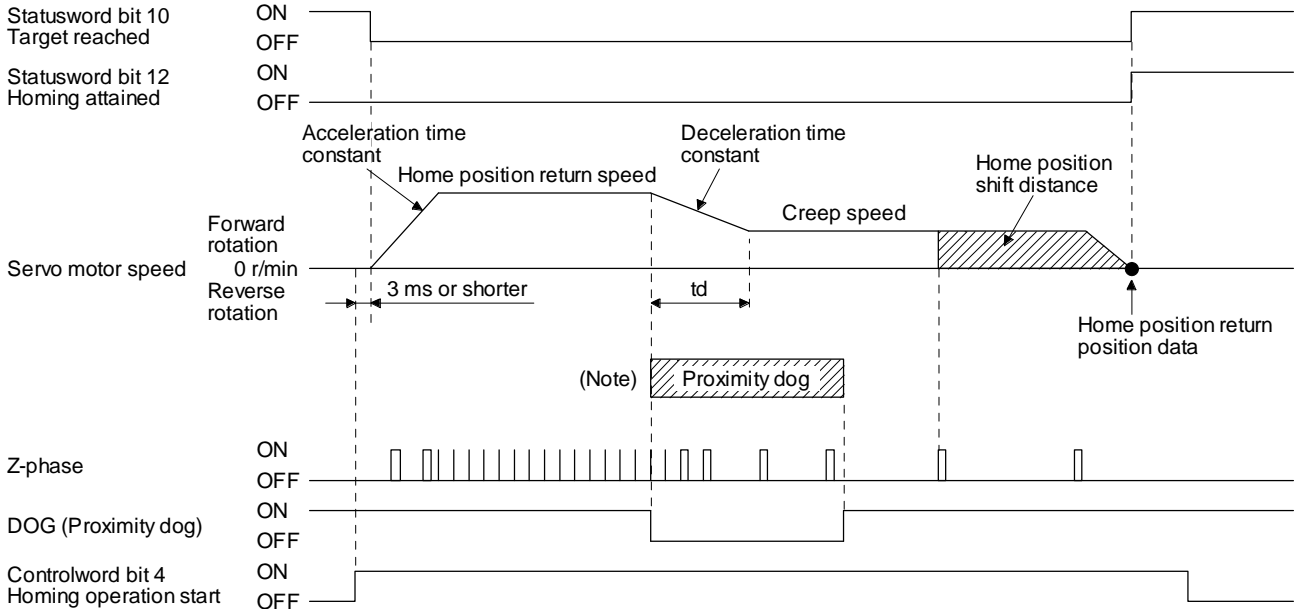

No te.	After the front end of the proximity dog is detected, if the distance after proximity dog is traveled without reaching the creep speed, [AL. 90] occurs. Set the travel distance after proximity dog enough for deceleration from the home position return speed to the creep speed.
--------	--

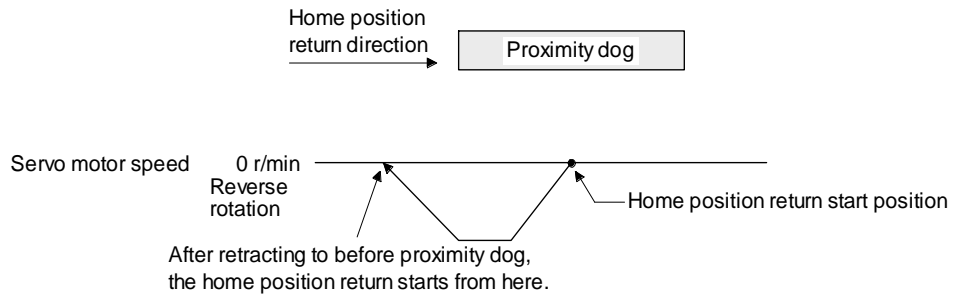

When a home position return is started from the proximity dog

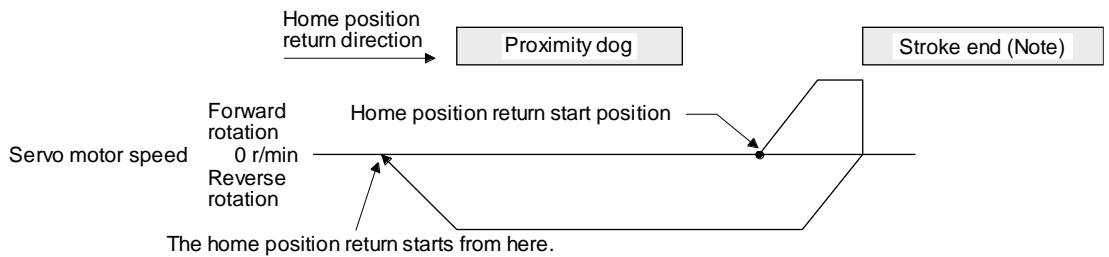

No te.	The software limit cannot be used with these functions.
--------	---

When the movement is returned at the stroke end

2) Torque limit changing dog type home position return

POINT

● Torque limit changing dog type home position return is available with drivers .

The following figure shows the operation of Homing method -1 in the indexer method. The operation direction of Homing method -33 is opposite to that of Homing method -1.

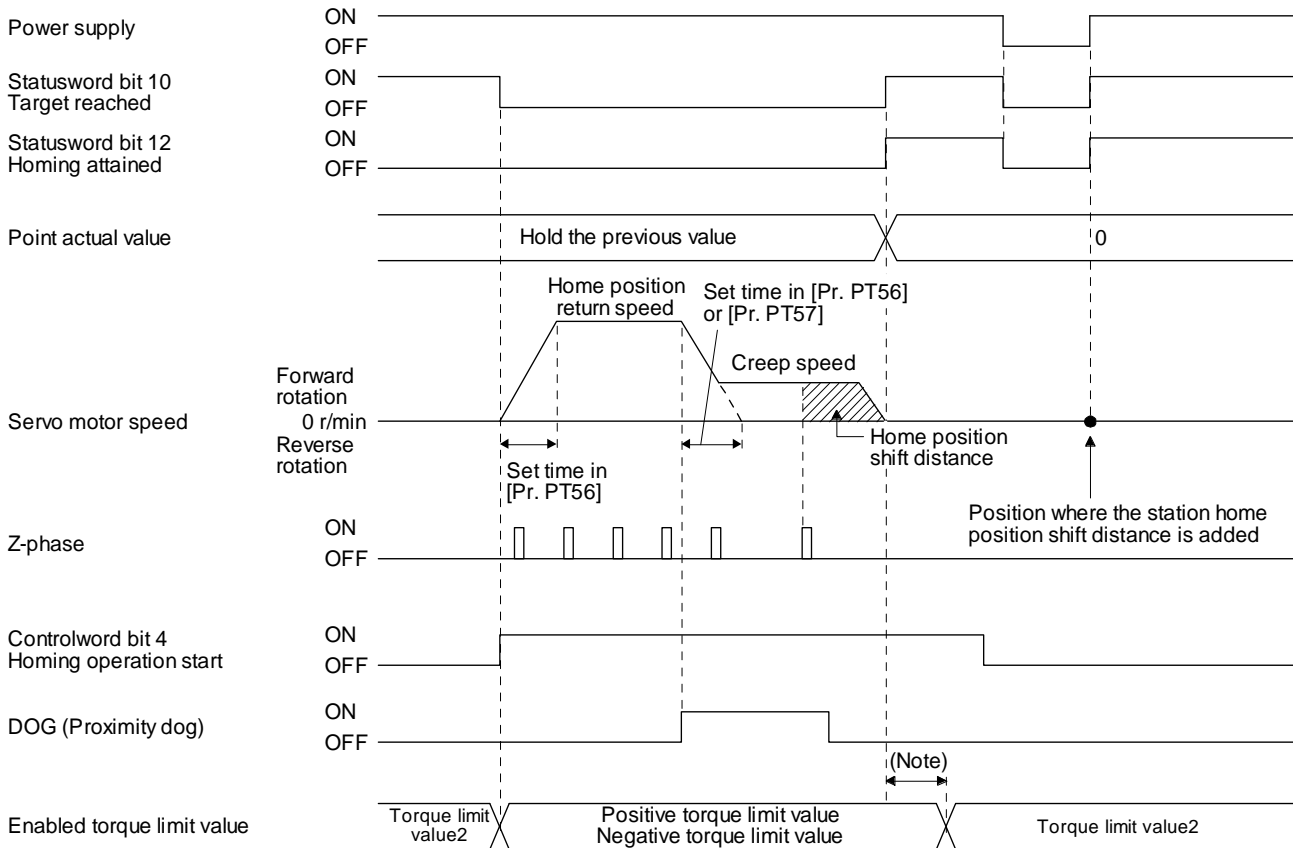

Note. A delay time can be set with [Pr. PT39].

(b) Method -2 and -34 (Count type home position return)

POINT

●For the count type home position return, after the front end of the proximity dog is detected, the position is shifted by the distance set in the travel distance after proximity dog. Then, the first Z-phase is set as the home position. Therefore, when the on-time of the proximity dog is 10 ms or more, the length of the proximity dog has no restrictions. Use this home position return type when the dog type home position return cannot be used because the length of the proximity dog cannot be reserved or other cases.

The following figure shows the operation of Homing method -2. The operation direction of Homing method -34 is opposite to that of Homing method -2.

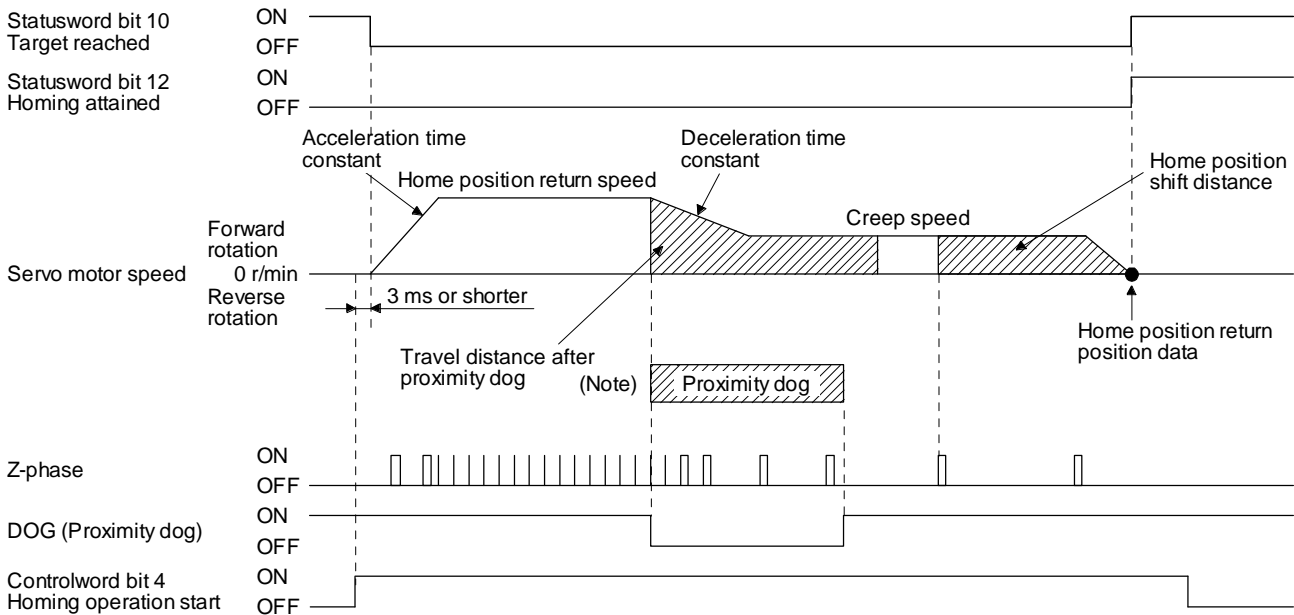

No te. After the front end of the proximity dog is detected, if the distance after proximity dog is traveled without reaching the creep speed, [AL. 90] occurs. Set the travel distance after proximity dog enough for deceleration from the home position return speed to the creep speed.

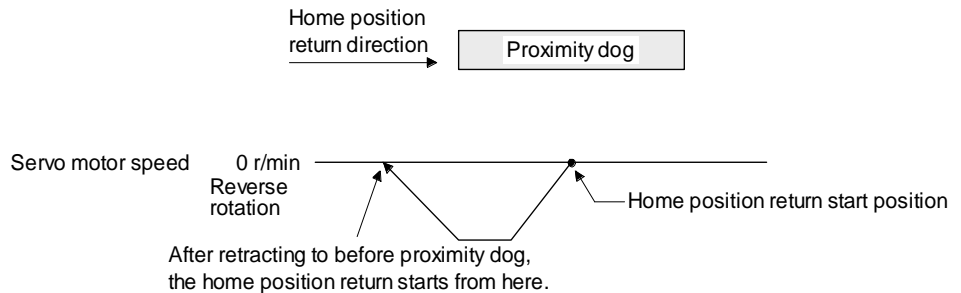

When a home position return is started from the proximity dog

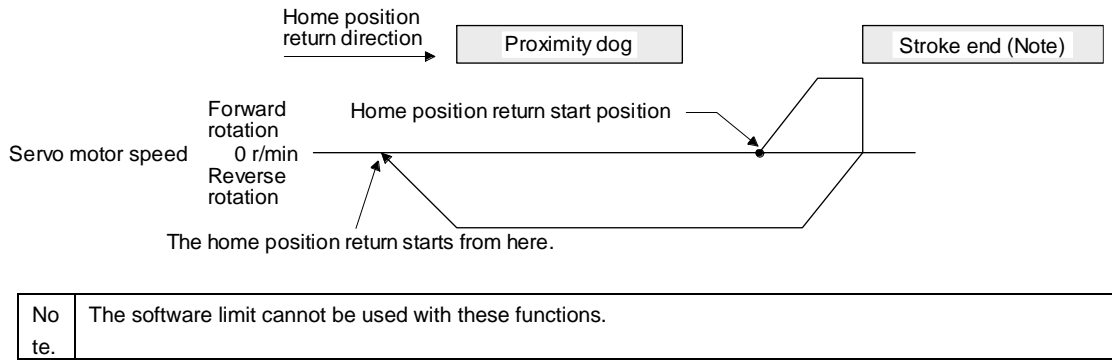

When the movement is returned at the stroke end

(c) Method -3

1) Data set type home position return

The following figure shows the operation of Homing method -3. This type cannot be executed during servo-off.



2) Torque limit changing data set type home position return

POINT
● Torque limit changing data set type home position return is available with drivers

The following figure shows the operation of Homing method -3 in the indexer method. This type cannot be executed during servo-off.

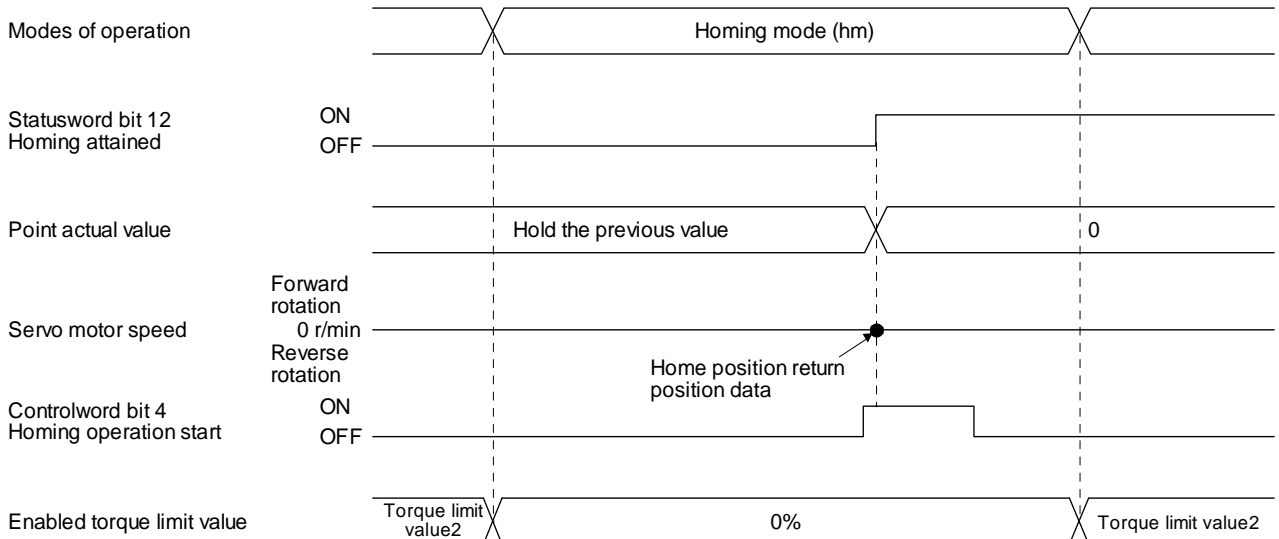

(d) Method -4 and -36 (stopper type home position return)

POINT

● Since the workpiece collides with the mechanical stopper, the home position return speed must be low enough.

The following figure shows the operation of Homing method -4. The operation direction of Homing method -36 is opposite to that of Homing method -4.

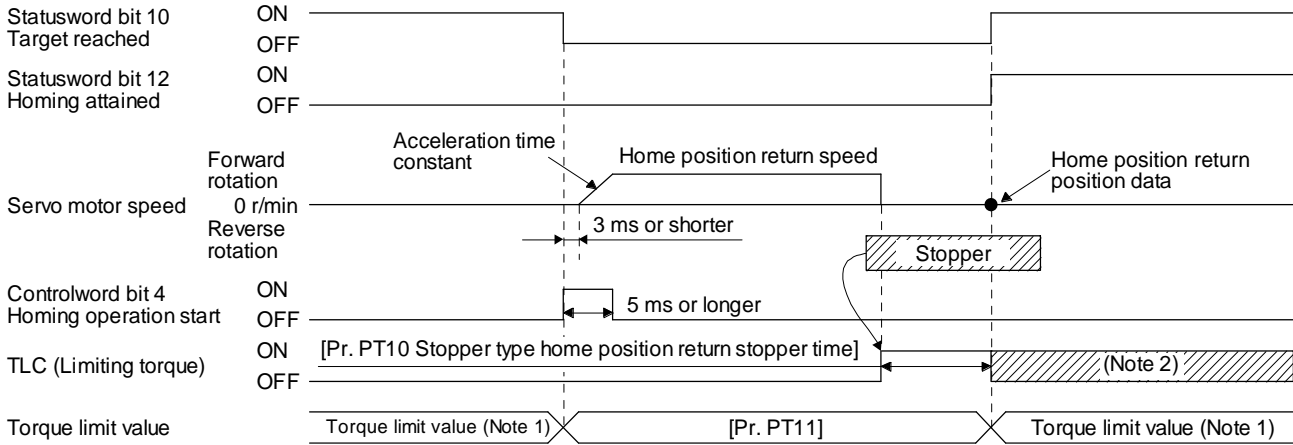

Note 1	When Method -4 is set, the torque limit value of Positive torque limit value (60E0h) is applied. When Method -36 is set, the torque limit value of Negative torque limit value (60E1h) is applied.
2	If the torque limit value is reached, TLC remains on after the home position return is completed.

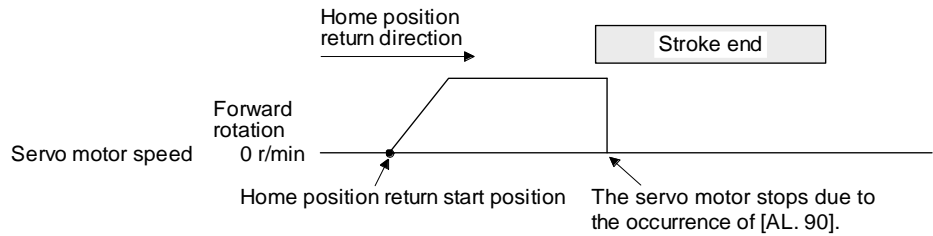

When the stroke end is detected

(e) Method -6 and -38 (dog type rear end reference home position return)

POINT

● This home position return type depends on the timing of reading DOG (Proximity dog) that has detected the rear end of the proximity dog. Therefore, when the creep speed is set to 100 r/min and a home position return is performed, the home position has an error of $\pm (\text{Encoder resolution}) \times 100/65536$ [pulse]. The higher the creep speed, the greater the error of the home position.

The following figure shows the operation of Homing method -6. The operation direction of Homing method -38 is opposite to that of Homing method -6.

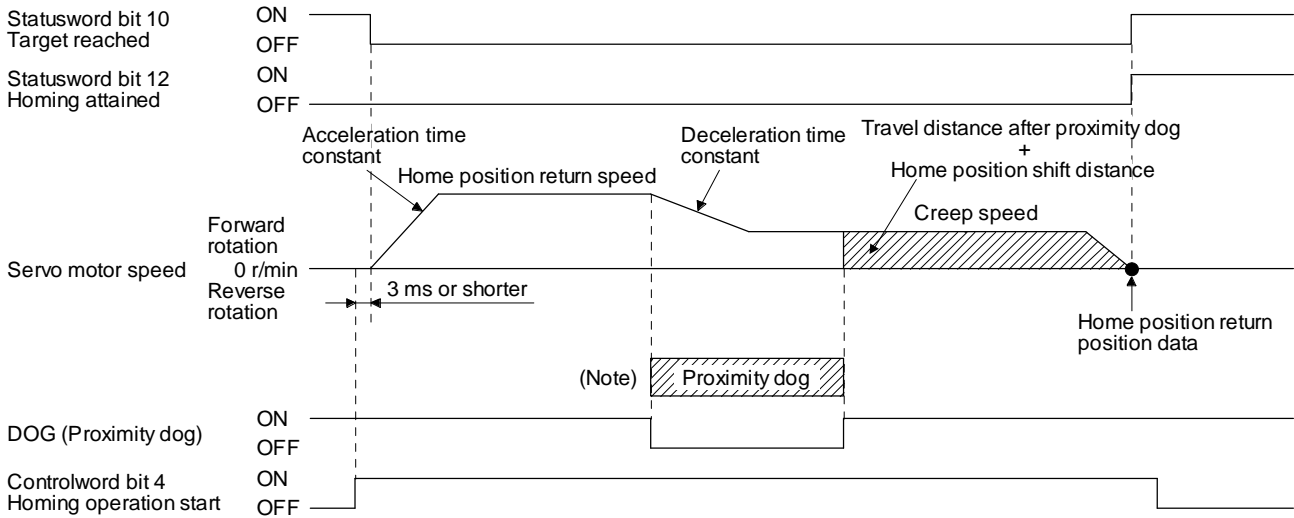

No te. After the front end of the proximity dog is detected, if the rear end of the proximity dog is detected without reaching the creep speed, [AL. 90] occurs. Check the length of the proximity dog or check the home position return speed and creep speed.

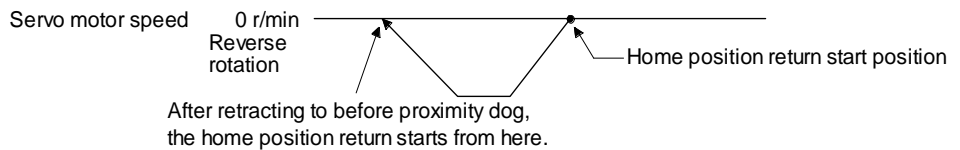

When a home position return is started from the proximity dog

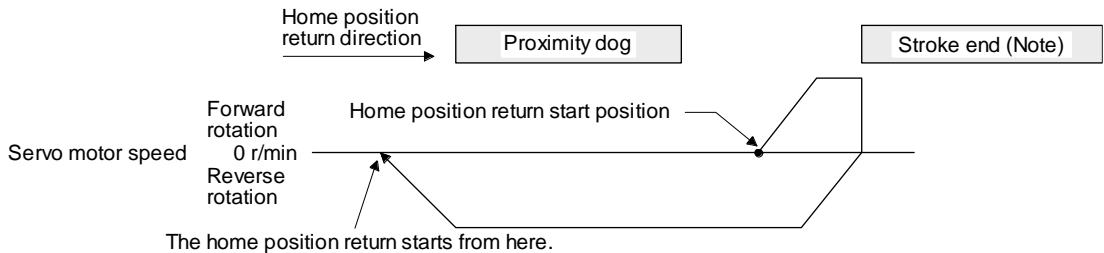

Note. The software limit cannot be used with these functions.

When the movement is returned at the stroke end

(f) Method -7 and -39 (count type front end reference home position return)

POINT

● This home position return type depends on the timing of reading DOG (Proximity dog) that has detected the front end of the proximity dog. Therefore, when the creep speed is set to 100 r/min and a home position return is performed, the home position has an error of $\pm (\text{Encoder resolution}) \times 100/65536$ [pulse]. The faster home position return speed sets a larger error in the home position.

The following figure shows the operation of Homing method -7. The operation direction of Homing method -39 is opposite to that of Homing method -7.

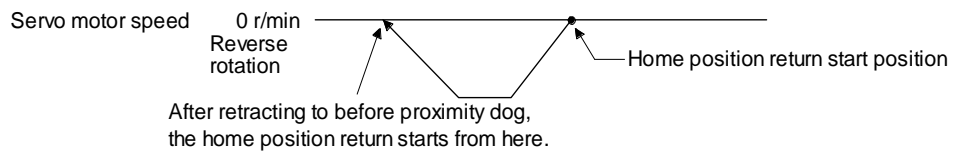
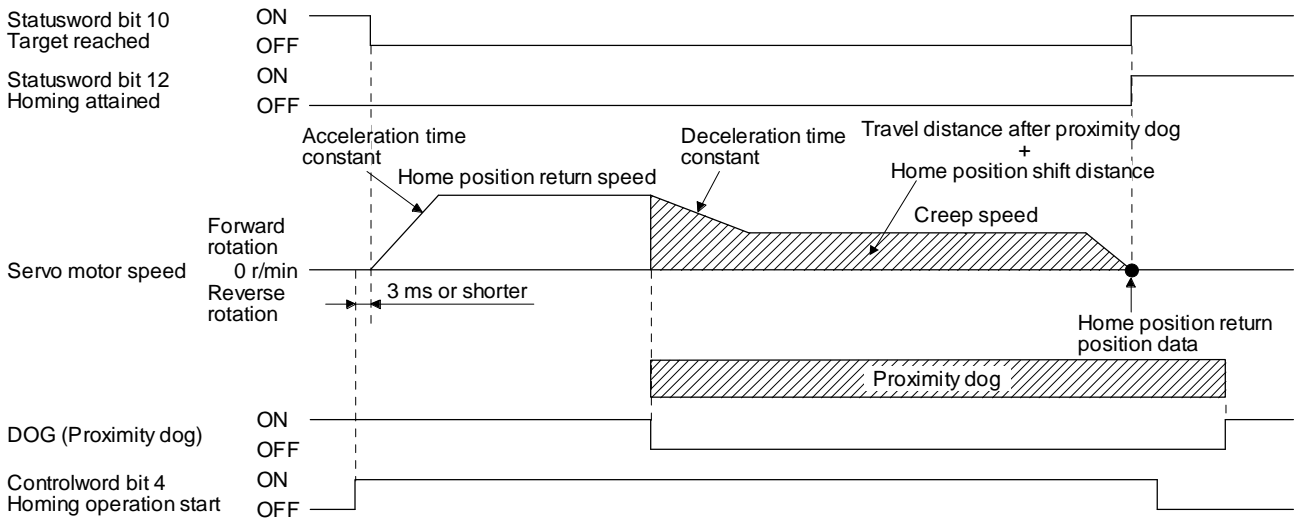

When a home position return is started from the proximity dog

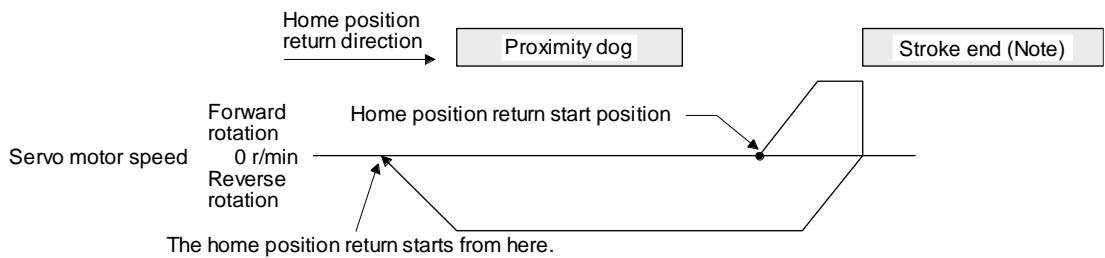

No te. The software limit cannot be used with these functions.

When the movement is returned at the stroke end

(g) Method -8 and -40 (dog cradle type home position return)

The following figure shows the operation of Homing method -8. The operation direction of Homing method -40 is opposite to that of Homing method -8.

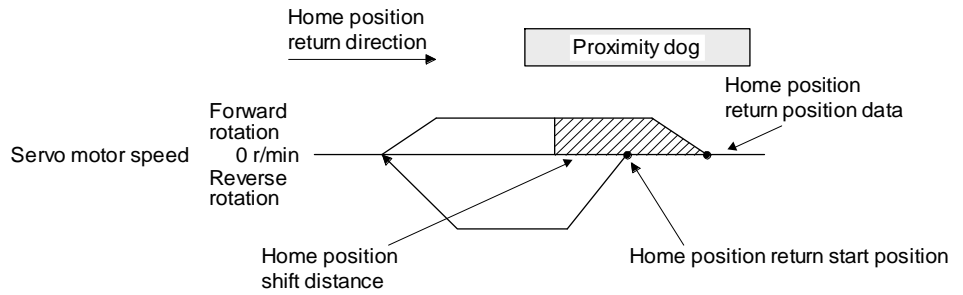
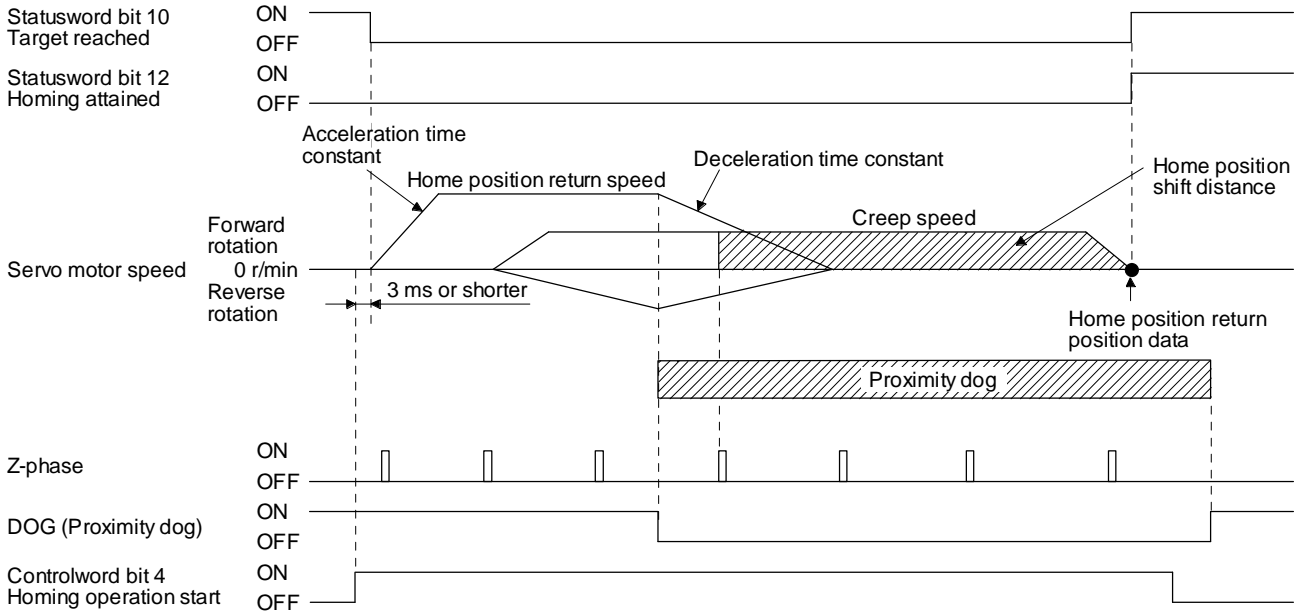

When a home position return is started from the proximity dog

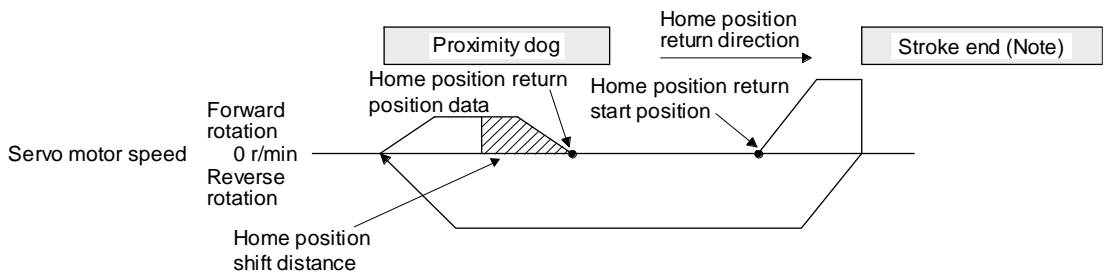

No	The software limit cannot be used with these functions.
te.	

When the movement is returned at the stroke end

(h) Method -9 and -41 (dog type last Z-phase reference home position return)

The following figure shows the operation of Homing method -9. The operation direction of Homing method -41 is opposite to that of Homing method -9.

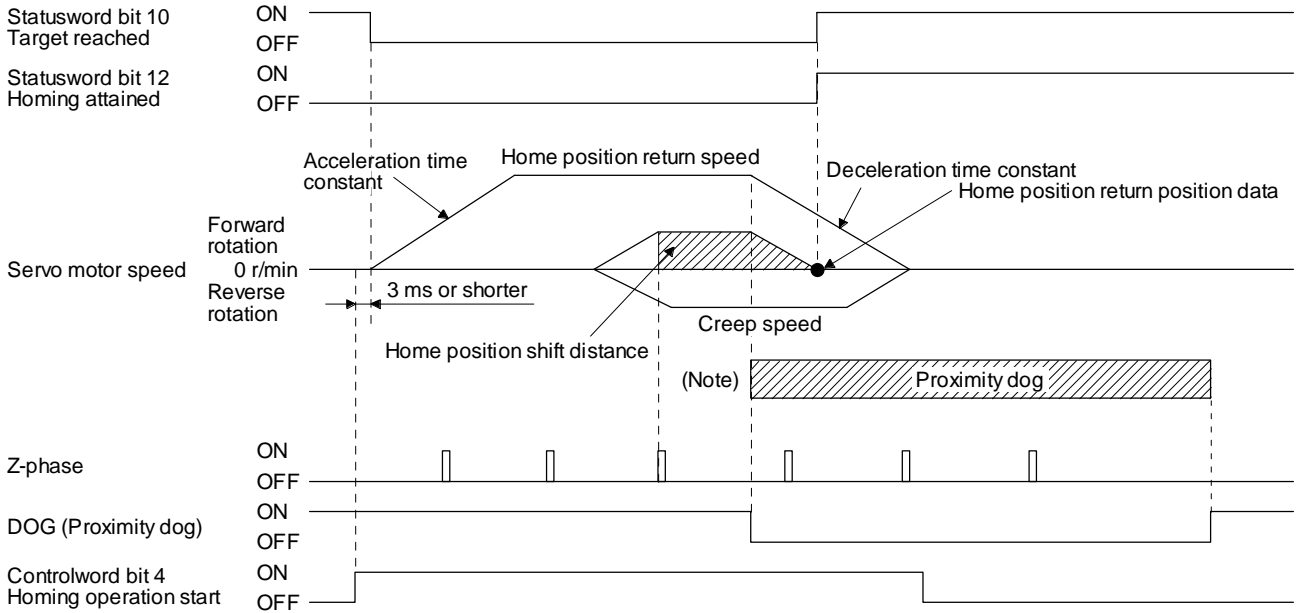

No	After the front end of the proximity dog is detected, if the rear end of the proximity dog is detected without stop, [AL. 90] occurs.
te.	Check the length of the proximity dog or check the home position return speed and creep speed.

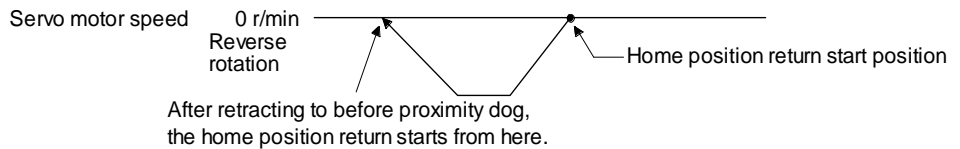

When a home position return is started from the proximity dog

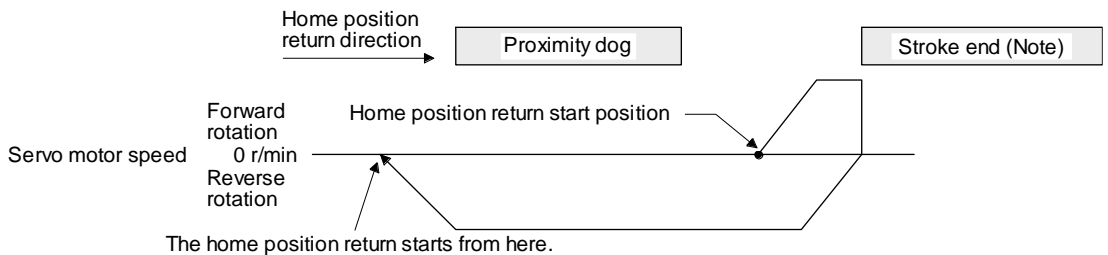

No	The software limit cannot be used with these functions.
te.	

When the movement is returned at the stroke end

(i) Method -10 and -42 (dog type front end reference home position return)

The following figure shows the operation of Homing method -10. The operation direction of Homing method -42 is opposite to that of Homing method -10.

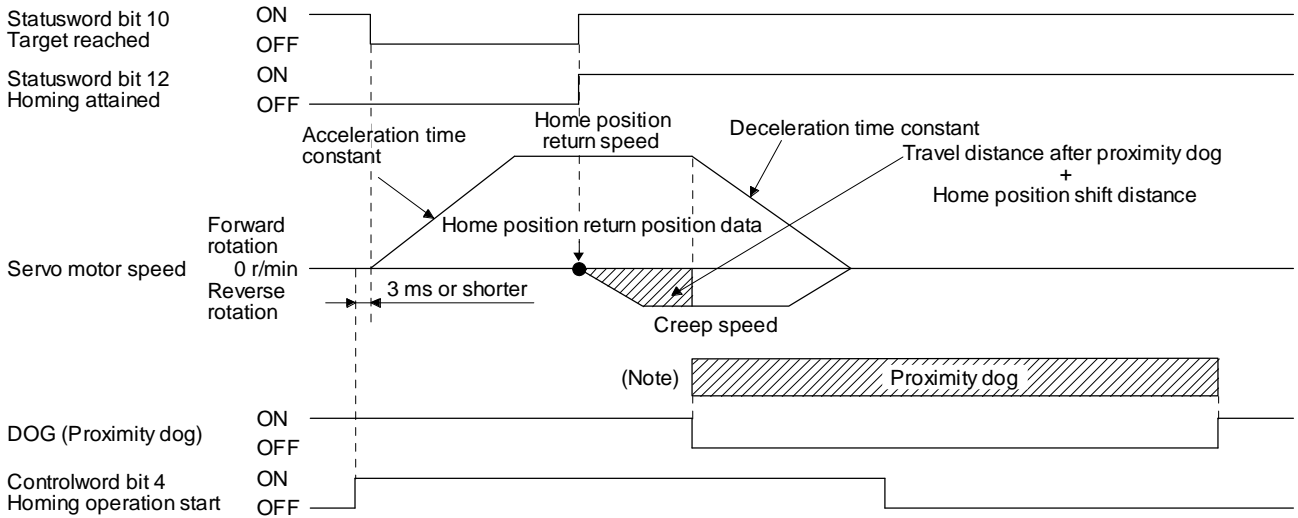

No te.	After the front end of the proximity dog is detected, if the rear end of the proximity dog is detected without reaching the creep speed, [AL. 90] occurs. Check the length of the proximity dog or check the home position return speed and creep speed.
--------	--

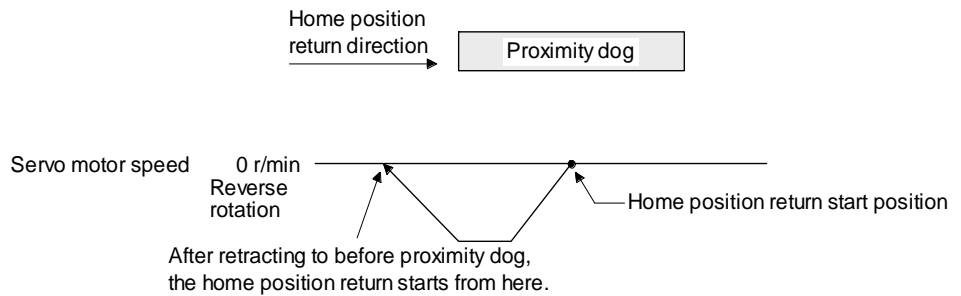

When a home position return is started from the proximity dog

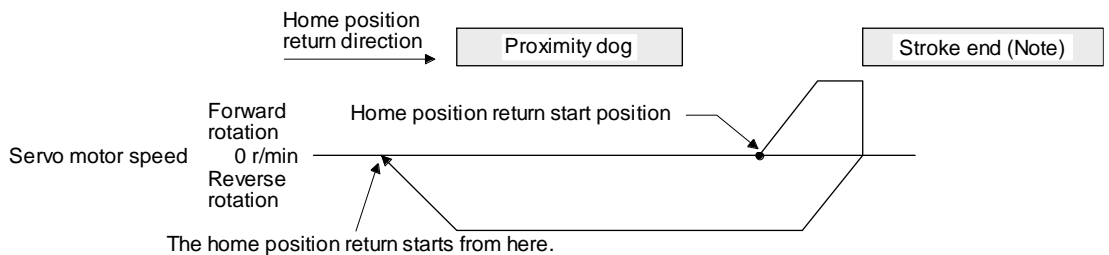

No te.	The software limit cannot be used with these functions.
--------	---

When the movement is returned at the stroke end

(j) Method -11 and -43 (dogless Z-phase reference home position return)

The following figure shows the operation of Homing method -11. The operation direction of Homing method -43 is opposite to that of Homing method -11.

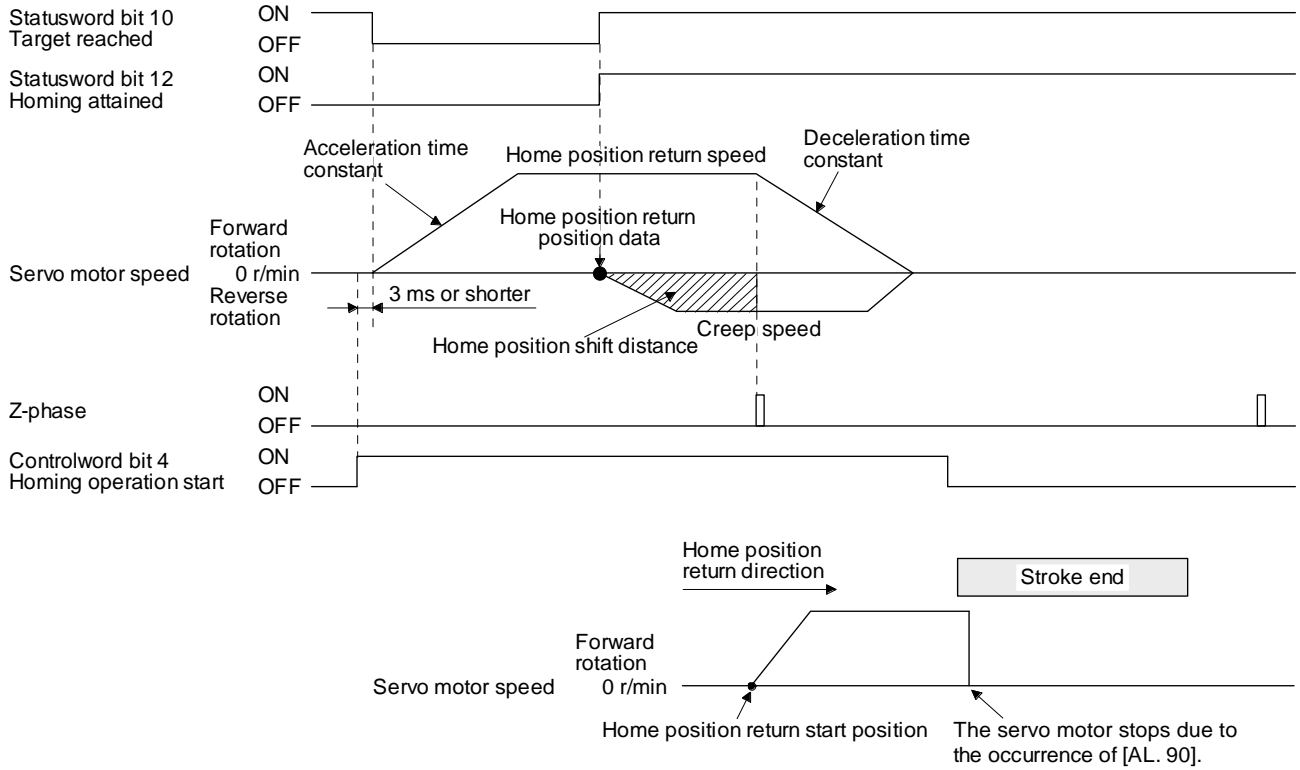

When the stroke end is detected

18.5.4.10 Point table mode (pt)

POINT
●Point table mode (pt) is available with drivers.

The following shows the functions and related objects of the point table mode (pt).

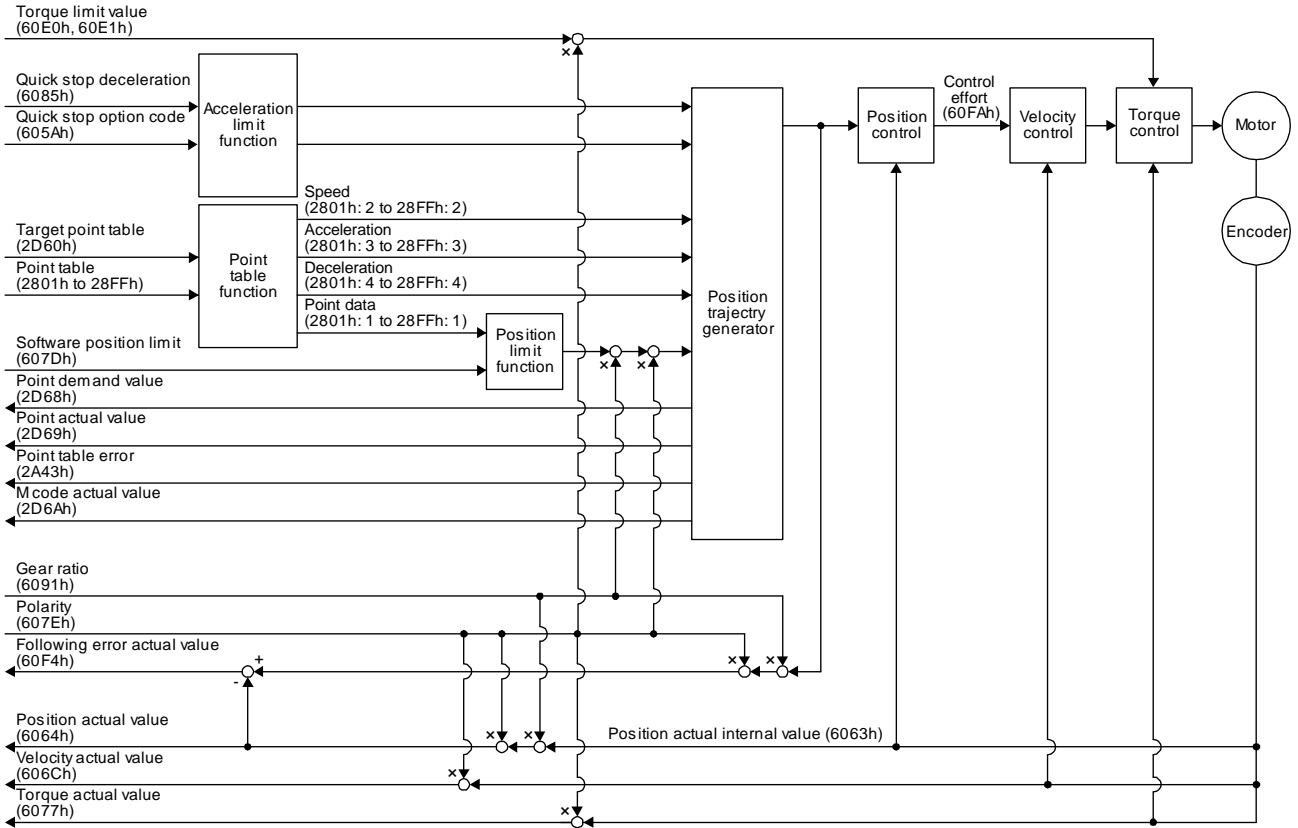

(1) Related object

Index	Sub	Object	Name	Data Type	Access	Default	Description
607Bh	0	ARRAY	Position range limit	U8	ro	2	Number of entries
	1		Min position range limit	I32	rw		Minimum value of the position range limit The value is automatically set according to the setting of "Position data unit" of [Pr. PT01]. mm/inch/pulse: -2147483648
	2		Max position range limit	I32	rw		Maximum value of the position range limit The value is automatically set according to the setting of "Position data unit" of [Pr. PT01]. mm/inch/pulse: 2147483647
607Dh	0	ARRAY	Software position limit	U8	ro	2	Number of entries
	1		Min position limit	I32	rw	0	Minimum position address (Pos units)
	2		Max position limit	I32	rw	0	Maximum position address (Pos units)

18. EtherCAT COMMUNICATION

Index	Sub	Object	Name	Data Type	Access	Default	Description
6085h		VAR	Quick stop deceleration	U32	rw	100	Deceleration at deceleration to a stop by Quick stop Unit: ms
605Ah		VAR	Quick stop option code	I16	rw	2	Operation setting for Quick stop Refer to section 5.6.
6063h		VAR	Position actual internal value	I32	ro		Current position (Enc inc)
6064h		VAR	Position actual value	I32	ro		Current position (Pos units)
606Ch		VAR	Velocity actual value	I32	ro		Current speed Unit: Vel unit (0.01 r/min or 0.01 mm/s)
6077h		VAR	Torque actual value	I32	ro		Current torque Unit: 0.1% (rated torque of 100%)
6092h	0	ARRAY	Feed constant	U8	ro	2	Travel distance per revolution of an output shaft
	1		Feed	U32	rw		Travel distance Refer to section 7.3.14 (4).
	2		Shaft revolutions				Number of servo motor shaft revolutions Refer to section 7.3.14 (4).
60F4h		VAR	Following error actual value	I32	ro		Droop pulses (Pos units)
60FAh		VAR	Control effort	I32	ro		Position control loop output (speed command) Unit: Vel unit (0.01 r/min or 0.01 mm/s)
60E0h		VAR	Positive torque limit value	U16	rw	10000	Torque limit value (forward) Unit: 0.1% (rated torque of 100%)
60E1h		VAR	Negative torque limit value	U16	rw	10000	Torque limit value (reverse) Unit: 0.1% (rated torque of 100%)
6091h	0	ARRAY	Gear ratio	U8	ro	2	Gear ratio
	1		Motor revolutions	U32	rw	1	Number of revolutions of the servo motor axis (numerator)
	2		Shaft revolutions			1	Number of revolutions of the drive axis (denominator)
607Eh		VAR	Polarity	U8	rw	0	Polarity selection Bit 7: Position POL Bit 6: Velocity POL Bit 5: Torque POL Refer to section 5.10.
60A8h		VAR	SI unit position	U32	rw	0	SI unit position The value is automatically set according to the setting of "Position data unit" of [Pr. PT01]. Refer to section 7.3.14 (5).
60A9h		VAR	SI unit velocity	U32	rw	0	SI unit velocity 0.01 r/min or 0.01 mm/s FB010300h (0.01 mm/s) FEB44700h (0.01 r/min)
2D60h		VAR	Target point table	I16	rw	0	0: Not operate 1 to 255: Execute the specified point table -1: High-speed home position return
2D68h		VAR	Point demand value	I16	ro		The currently specified point table No. is returned. While the servo motor is stopped, the value becomes the set value of the Target point table (2D60h).
2D69h		VAR	Point actual value	I16	ro		The completed point table is returned.

18. EtherCAT COMMUNICATION

Index	Sub	Object	Name	Data Type	Access	Default	Description
2801h to 28FFh	0	ARRAY	Point table 001 to 255	U8	ro	7	Number of entries Point table
	1		Point data	I32	rw		Position data Unit: pos units
	2		Speed	I32	rw		Speed Unit: 0.01 r/min or 0.01 mm/s
	3		Acceleration	I32	rw		Acceleration time constant Unit: ms
	4		Deceleration	I32	rw		Deceleration time constant Unit: ms
	5		Dwell	I32	rw		Dwell Unit: ms
	6		Auxiliary	I32	rw		Auxiliary function Refer to section 7.3.17 (4).
	7		M code	I32	rw		M code
2A43h	0	ARRAY	Point table error	U8	ro	2	Number of entries Point table error
	1		Point table error No.	I32	ro		Point table error number
	2		Point table error factor	I32	ro		Point table error factor The error status is indicated when this bit is turned on. Refer to section 7.3.17 (5).
2D6Ah		VAR	M code actual value	U8	ro		The completed M code of the point table is returned.

(2) Details on the OMS bit of Controlword (pt mode)

Bit	Symbol	Description
4	New set-point	The operation starts from the point table specified with the Target point table (2D60h) when the Bit turns on.
5	(reserved)	The value at reading is undefined. Set "0" when writing.
6	(reserved)	
8	HALT	0: Positioning is executed. 1: The servo motor stops according to Halt option code (605Dh).
9	(reserved)	The value at reading is undefined. Set "0" when writing.

(3) Details on the OMS bit of Statusword (pt mode)

Bit	Symbol	Description
10	Target reached	0 (Halt (Bit 8) = 0): Target position not reached. 0 (Halt (Bit 8) = 1): Axis decelerates 1 (Halt (Bit 8) = 0): Target position reached. 1 (Halt (Bit 8) = 1): Velocity of axis is 0 Judgment condition for Target position reached When the current position and the point table command position vary within Position window (6067h) and this state exceeds Position window time (6068h), this bit becomes Target position reached.
12	Set-point acknowledge	0: Positioning completed (wait for next command) 1: Positioning being executed
13	Following error	0: No following error 1: Following error Judgment condition for Following error When the time set with Following error time out (6066h) has elapsed with the number of droop pulses exceeding the set value of the Following error window (6065h), this bit becomes "1".

(4) pt mode operation sequence

(a) Automatic individual positioning operation

While the servo motor is stopped under servo-on state, switching on "Controlword bit 4 (New set-point)" starts the automatic positioning operation.

The following shows a timing chart.

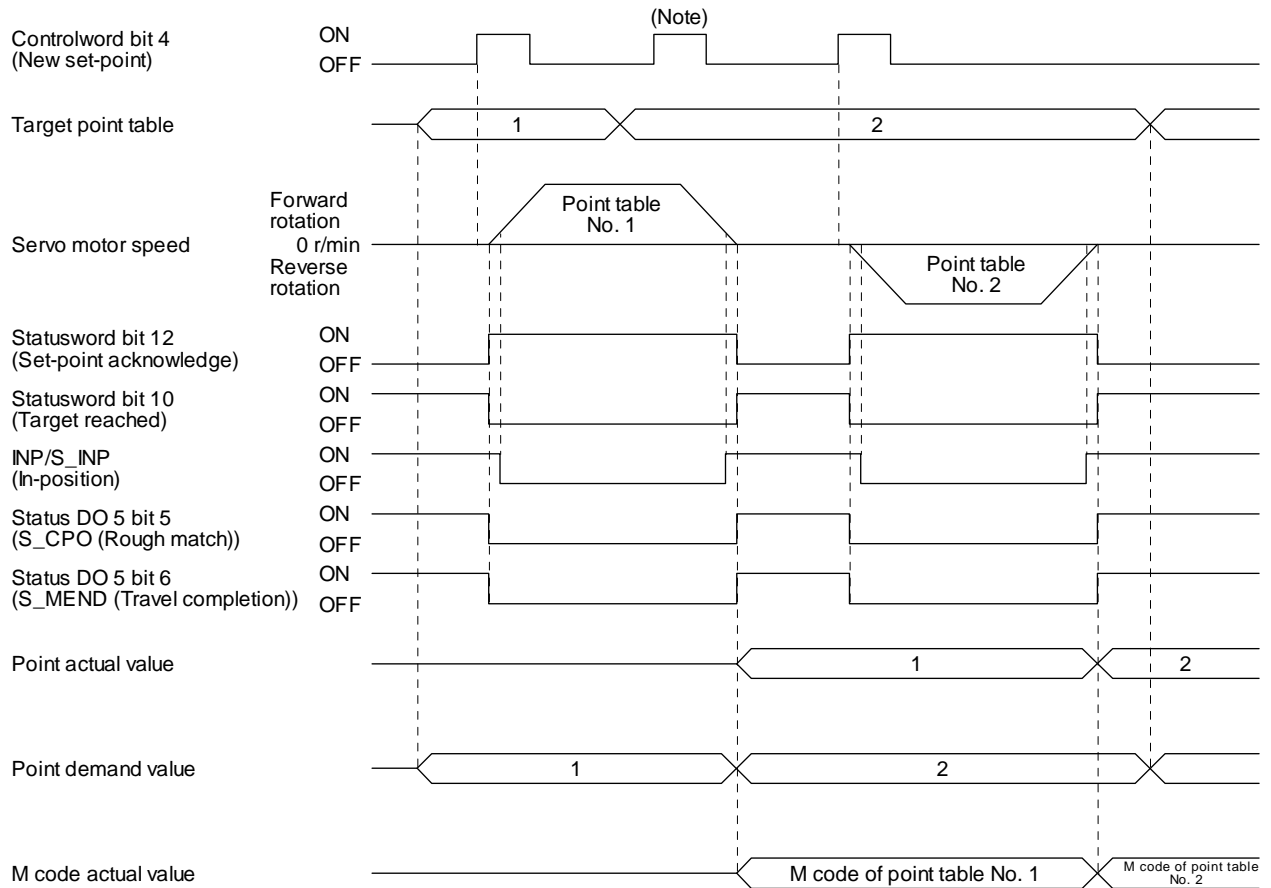

No te.	Switching on "Controlword bit 4 (New set-point)" is invalid while the servo motor is rotating.
--------	--

(b) Automatic continuous positioning operation

By merely selecting a point table and switching on "Controlword bit 4 (New set-point)", the operation can be performed in accordance with the point tables having consecutive numbers.

The following shows a timing chart.

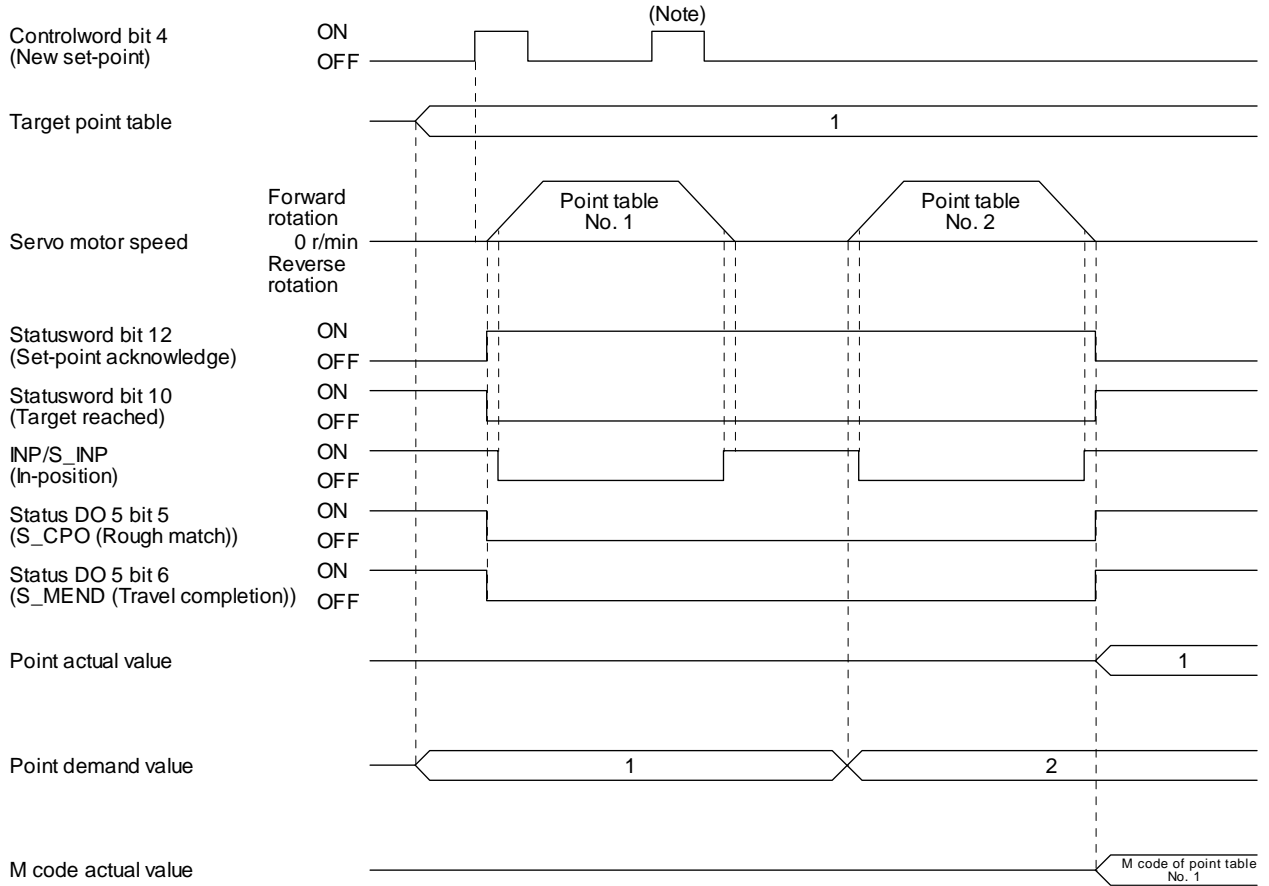

No te.	Switching on "Controlword bit 4 (New set-point)" is invalid while the servo motor is rotating.
--------	--

18.5.4.11 Jog mode (jg)

POINT

●Jog mode (jg) is available with drivers.

The following shows the function and related objects of the Jog mode (jg).

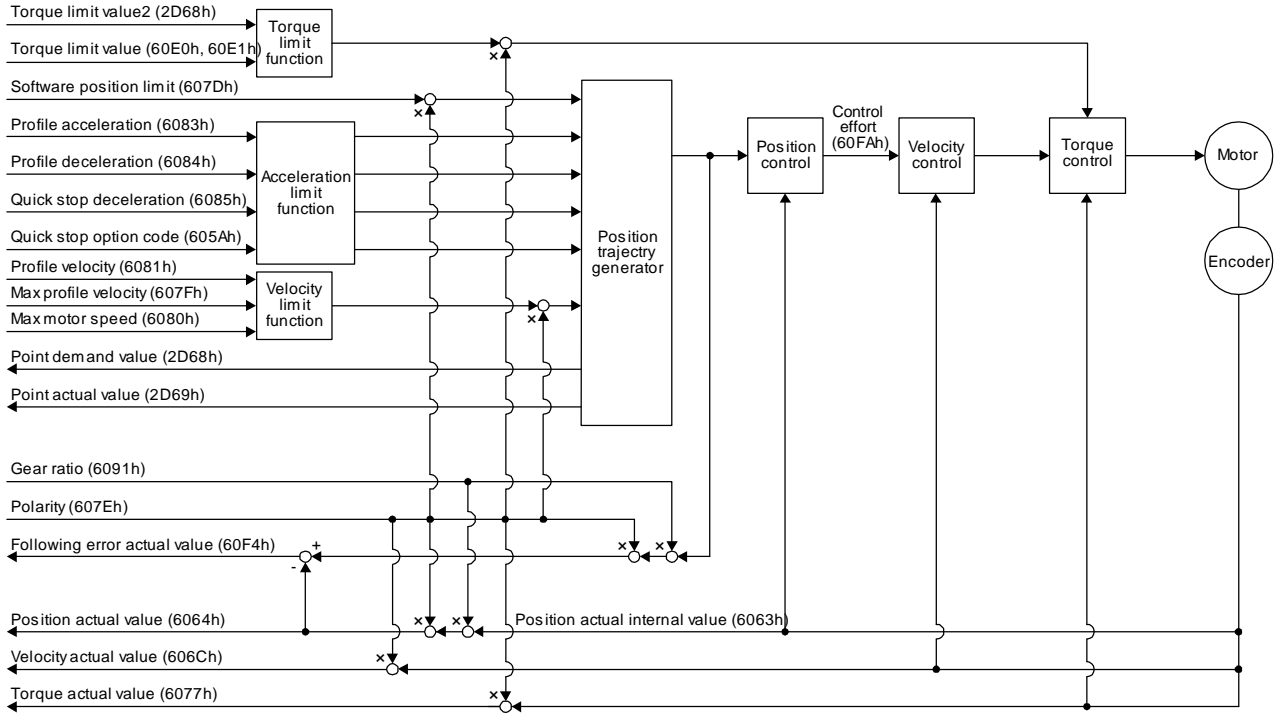

(1) Related object

Index	Sub	Object	Name	Data Type	Access	Default	Description
607Bh	0	ARRAY	Position range limit	U8	ro	2	Number of entries
	1		Min position range limit	I32	rw		Minimum value of the position range limit The value is automatically set according to the setting of "Position data unit" of [Pr. PT01]. mm/inch/pulse: -2147483648 In the indexer method, the value becomes "0".
	2		Max position range limit	I32	rw		Maximum value of the position range limit The value is automatically set according to the setting of "Position data unit" of [Pr. PT01]. mm/inch/pulse: 2147483647 In the indexer method, the value becomes the set value of [Pr. PT28 Number of stations per rotation] -1.

18. EtherCAT COMMUNICATION

Index	Sub	Object	Name	Data Type	Access	Default	Description
607Dh	0	ARRAY	Software position limit	U8	ro	2	Number of entries
	1		Min position limit	I32	rw	0	Minimum position address (Pos units) This cannot be used in the indexer method.
	2		Max position limit	I32	rw	0	Maximum position address (Pos units) This cannot be used in the indexer method.
607Fh		VAR	Max profile velocity	U32	rw	2000000	maximum speed Unit: Vel unit (0.01 r/min or 0.01 mm/s)
6080h		VAR	Max motor speed	U32	rw		Servo motor maximum speed Unit: r/min
6081h		VAR	Profile velocity	U32	rw	10000	Speed after acceleration completed Unit: Vel unit (0.01 r/min or 0.01 mm/s)
6083h		VAR	Profile Acceleration	U32	rw	0	Acceleration at start of movement to target position Unit: ms
6084h		VAR	Profile deceleration	U32	rw	0	Deceleration at arrival at target position Unit: ms
6085h		VAR	Quick stop deceleration	U32	rw	100	Deceleration at deceleration to a stop by Quick stop Unit: ms
605Ah		VAR	Quick stop option code	I16	rw	2	Operation setting for Quick stop Refer to section 5.6.
6063h		VAR	Position actual internal value	I32	ro		Current position (Enc inc)
6064h		VAR	Position actual value	I32	ro		Current position (Pos units) In the indexer method, the value is fixed to 0.
606Ch		VAR	Velocity actual value	I32	ro		Current speed Unit: Vel unit (0.01 r/min or 0.01 mm/s) In the indexer method, this is available only in 0.01 r/min.
6077h		VAR	Torque actual value	I32	ro		Current torque Unit: 0.1% (rated torque of 100%)
6092h	0	ARRAY	Feed constant	U8	ro	2	Travel distance per revolution of an output shaft
	1		Feed	U32	rw		Travel distance Refer to section 7.3.14 (4).
	2		Shaft revolutions				Number of servo motor shaft revolutions Refer to section 7.3.14 (4).
60F4h		VAR	Following error actual value	I32	ro		Droop pulses (Pos units) (Note)
60FAh		VAR	Control effort	I32	ro		Position control loop output (speed command) Unit: Vel unit (0.01 r/min or 0.01 mm/s)
60E0h		VAR	Positive torque limit value	U16	rw	10000	Torque limit value (forward) Unit: 0.1% (rated torque of 100%)
60E1h		VAR	Negative torque limit value	U16	rw	10000	Torque limit value (reverse) Unit: 0.1% (rated torque of 100%)

18. EtherCAT COMMUNICATION

Index	Sub	Object	Name	Data Type	Access	Default	Description
6091h	0	ARRAY	Gear ratio	U8	ro	2	Gear ratio
	1		Motor revolutions	U32	rw	1	Number of revolutions of the servo motor axis (numerator) In the indexer method, this means the number of gear teeth on machine side.
	2		Shaft revolutions			1	Number of revolutions of the drive axis (denominator) In the indexer method, this means the number of gear teeth on servo motor side.
607Eh		VAR	Polarity	U8	rw	0	Polarity selection Bit 7: Position POL Bit 6: Velocity POL Bit 5: Torque POL Refer to section 5.10.
60A8h		VAR	SI unit position	U32	rw	0	SI unit position The value is automatically set according to the setting of "Position data unit" of [Pr. PT01]. Refer to section 7.3.14 (5).
60A9h		VAR	SI unit velocity	U32	rw	0	SI unit velocity 0.01 r/min or 0.01 mm/s FB010300h (0.01 mm/s) FEB44700h (0.01 r/min) In the indexer method, this is available only in 0.01 r/min.
2D68h		VAR	Point demand value	I16	ro		In the point table method, the value is 0. In the indexer method, the next station No. is set.
2D69h		VAR	Point actual value	I16	ro		In the point table method, the previous value is held. In the indexer method, the station No. at which the servo motor has stopped is set. However, the previous value is held when S_MEND is off.
2D6Bh		VAR	Torque limit value2	U16	rw	10000	Torque limit value 2 Unit: 0.1% (rated torque of 100%) Set a torque limit value for when the servo motor is stopped. This can be used only in the indexer method.

Note. In the indexer method, the unit is the command unit [pulse] (a load-side rotation expressed by the number of servo motor resolution pulses).

(2) Details on the OMS bit of Controlword (jg mode)

Bit	Symbol	Description
4	Rotation start	0: Stop the servo motor 1: Start the servo motor
5	Direction	0: Forward rotation (address increase) 1: Reverse rotation (address decrease)
6	(reserved)	The value at reading is undefined. Set "0" when writing.
8	HALT	0: Positioning is executed. 1: The servo motor stops according to Halt option code (605Dh). In the indexer method, this bit is disabled.
9	(reserved)	The value at reading is undefined. Set "0" when writing.

(3) Details on the OMS bit of Statusword (jg mode)

Bit	Symbol	Description
10	Target reached	0 (Halt (Bit 8) = 0): Target position not reached. 0 (Halt (Bit 8) = 1): Axis decelerates 1 (Halt (Bit 8) = 0): Target position reached. 1 (Halt (Bit 8) = 1): Velocity of axis is 0 Judgment condition for Target position reached If the error between Position actual value (6064h) and Target position (607Ah) has stayed within Position window (6067h) for Position window time (6068h) or more, Target position reached is stored.
12	(reserved)	The value at reading is undefined.
13	Following error	0: No following error 1: Following error Judgment condition for Following error When the time set with Following error time out (6066h) has elapsed with the number of droop pulses exceeding the set value of the Following error window (6065h), this bit becomes "1".

(4) jg mode operation sequence in the point table method

(a) When operating at a constant speed

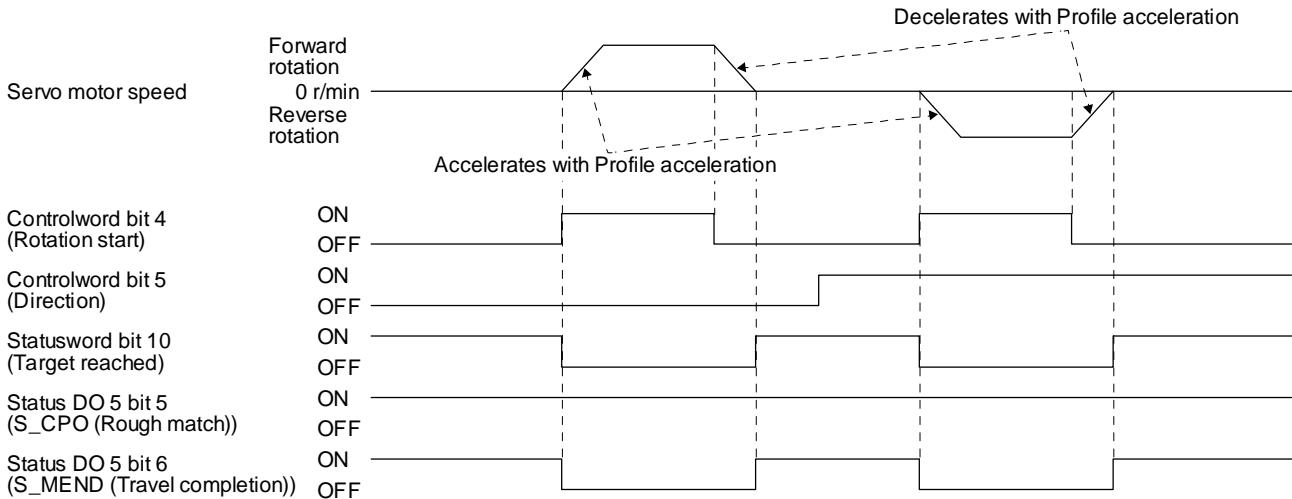

(b) When changing the speed during operation

You can change the servo motor speed by changing the "Profile velocity" during operation. However, the servo motor speed cannot be changed during deceleration. The acceleration time constant and the deceleration time constant can be changed only while the servo motor is stopped.

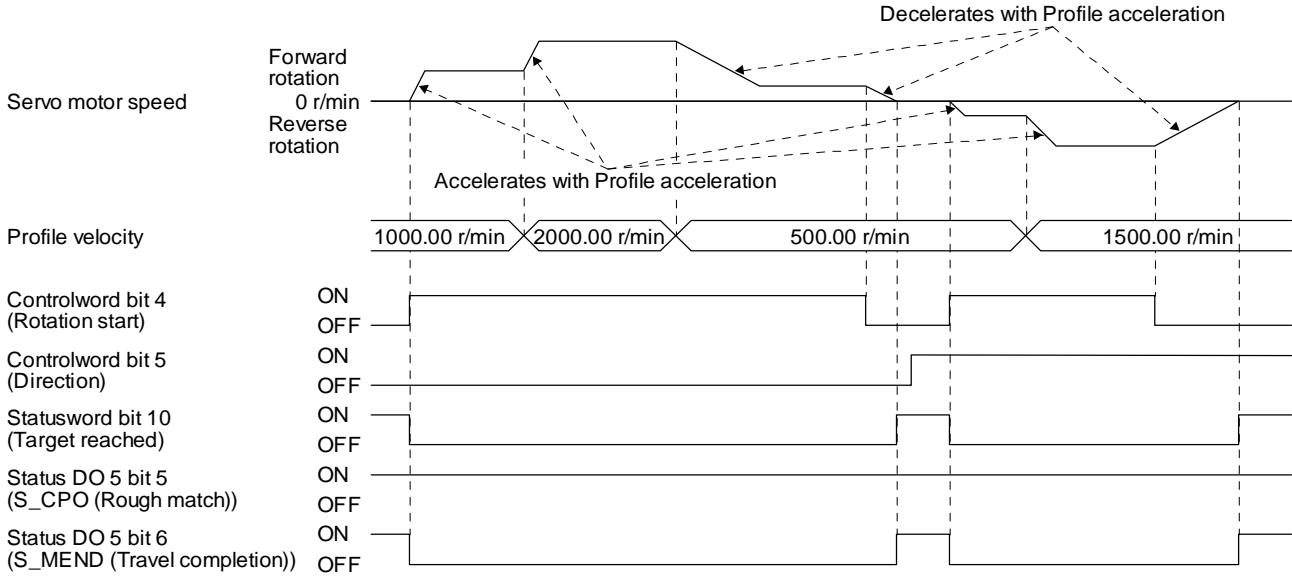

(5) jg mode operation sequence in the indexer method

(a) Station JOG operation

The following timing chart shows that a station JOG operation is performed at a stop of the station No. 0 when servo-on.

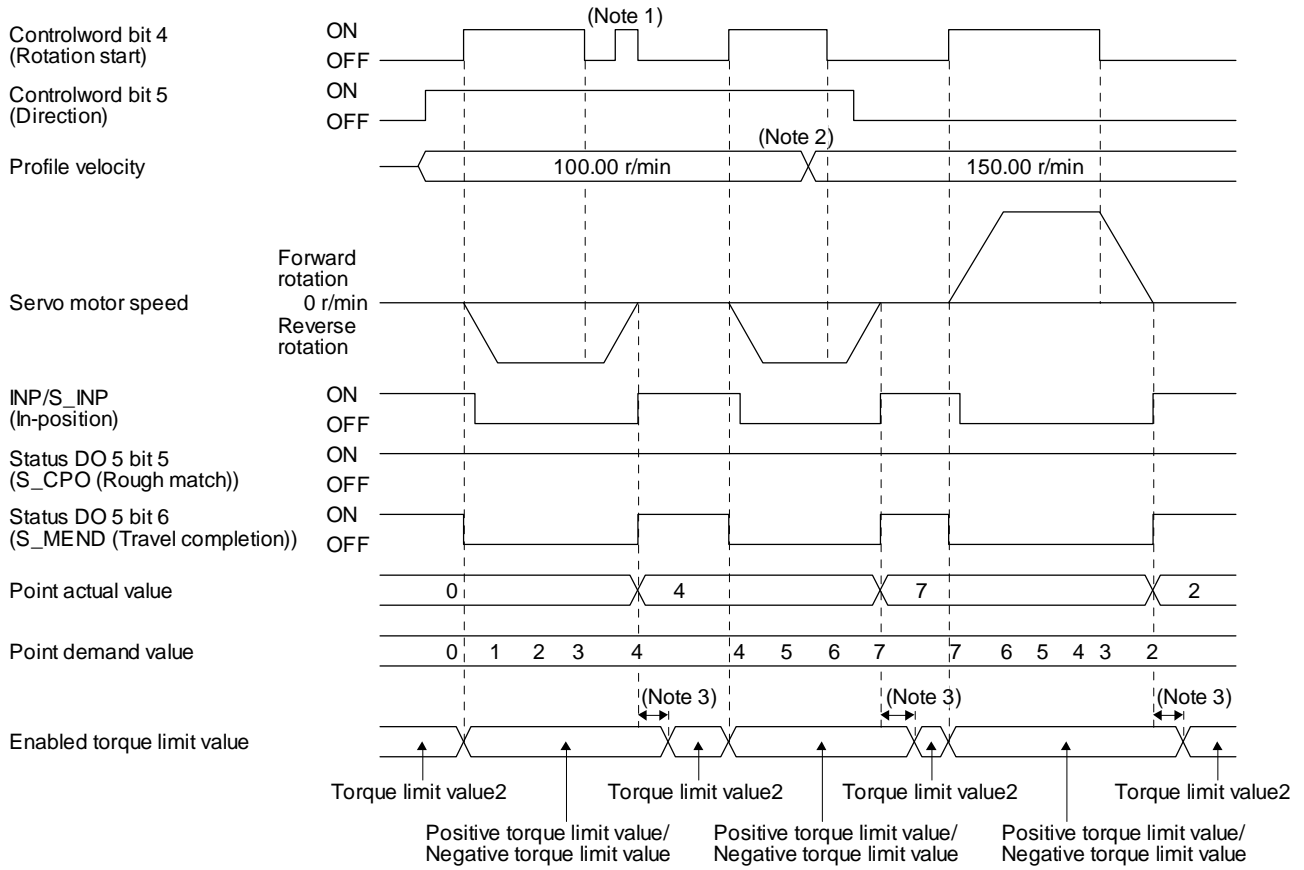

Note 1	"Controlword bit 4 (Rotation start)" is not received when the rest of command travel distance is other than "0".
Note 2	Switching "Profile velocity" during the servo motor rotation does not enable this.
Note 3	A delay time can be set with [Pr. PT39].

(b) JOG operation

The following timing chart shows that a JOG operation is performed at a stop of the station No. 0 when servo-on.

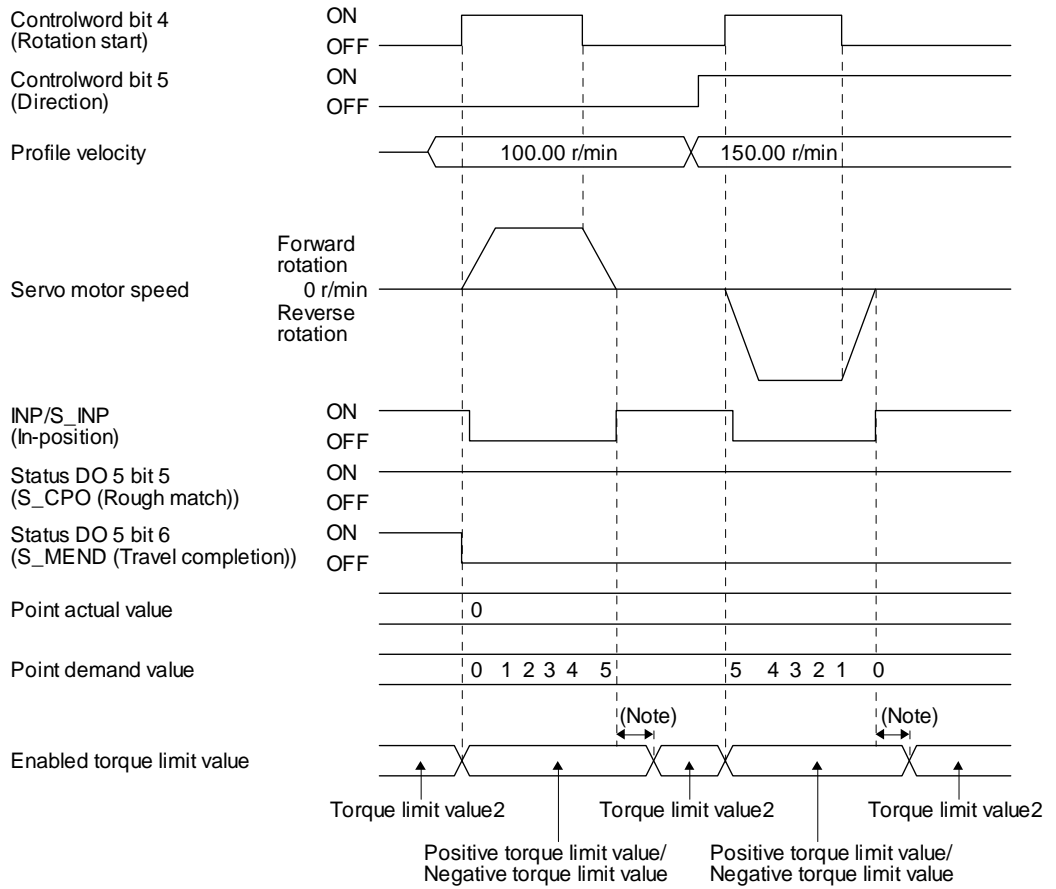

No	A delay time can be set with [Pr. PT39].
te.	

18. EtherCAT COMMUNICATION

18.5.4.12 Indexer mode (idx)

POINT
● Indexer mode (idx) is available with drivers.

The following shows the function and related objects of the indexer mode (idx).

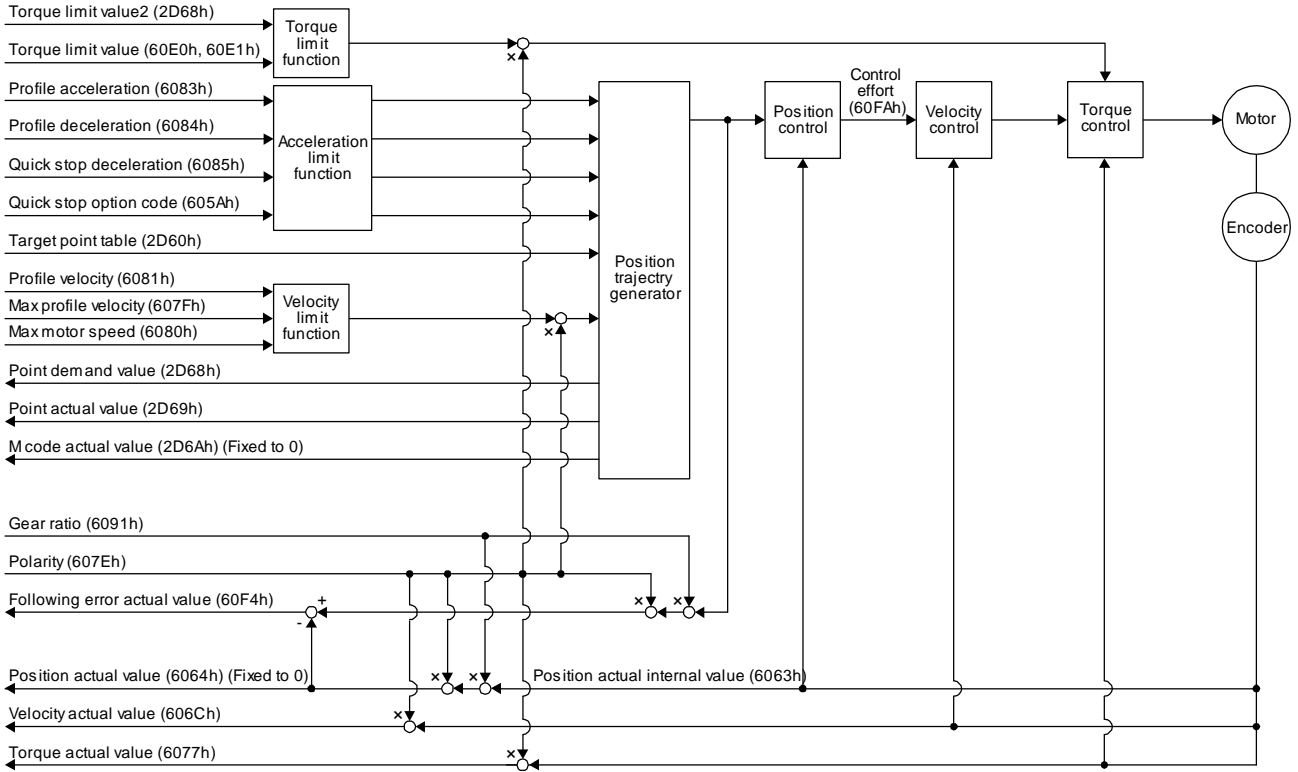

(1) Related object

Index	Sub	Object	Name	Data Type	Access	Default	Description
607Bh	0	ARRAY	Position range limit	U8	ro	2	Number of entries
	1		Min position range limit	I32	rw		Minimum value of the position range limit In the indexer method, the value becomes "0".
	2		Max position range limit	I32	rw		Maximum value of the position range limit In the indexer method, the value becomes the set value of [Pr. PT28 Number of stations per rotation] -1.
607Fh		VAR	Max profile velocity	U32	rw	2000000	maximum speed Unit: Vel unit (0.01 r/min)
6080h		VAR	Max motor speed	U32	rw		Servo motor maximum speed Unit: r/min
6081h		VAR	Profile velocity	U32	rw	10000	Speed after acceleration completed Unit: Vel unit (0.01 r/min)
6083h		VAR	Profile acceleration	U32	rw	0	Acceleration at start of movement to target position Unit: ms

18. EtherCAT COMMUNICATION

Index	Sub	Object	Name	Data Type	Access	Default	Description
6084h		VAR	Profile deceleration	U32	rw	0	Deceleration at arrival at target position Unit: ms
6085h		VAR	Quick stop deceleration	U32	rw	100	Deceleration at deceleration to a stop by Quick stop Unit: ms
605Ah		VAR	Quick stop option code	I16	rw	2	Operation setting for Quick stop Refer to section 5.6.
6063h		VAR	Position actual internal value	I32	ro		Current position (Enc inc)
6064h		VAR	Position actual value	I32	ro		Current position (Pos units) Fixed to 0
606Ch		VAR	Velocity actual value	I32	ro		Current speed Unit: Vel unit (0.01 r/min)
6077h		VAR	Torque actual value	I32	ro		Current torque Unit: 0.1% (rated torque of 100%)
6092h	0	ARRAY	Feed constant	U8	ro	2	Travel distance per revolution of an output shaft
	1		Feed	U32	rw		Travel distance Refer to section 7.3.14 (4).
	2		Shaft revolutions				Number of servo motor shaft revolutions Refer to section 7.3.14 (4).
60F4h		VAR	Following error actual value	I32	ro		Droop pulses (Pos units) (Note)
60FAh		VAR	Control effort	I32	ro		Position control loop output (speed command) Unit: Vel unit (0.01 r/min)
60E0h		VAR	Positive torque limit value	U16	rw	10000	Torque limit value (forward) Unit: 0.1% (rated torque of 100%)
60E1h		VAR	Negative torque limit value	U16	rw	10000	Torque limit value (reverse) Unit: 0.1% (rated torque of 100%)
6091h	0	ARRAY	Gear ratio	U8	ro	2	Gear ratio
	1		Motor revolutions	U32	rw	1	Number of gear teeth on machine side
	2		Shaft revolutions			1	Number of gear teeth on servo motor side
607Eh		VAR	Polarity	U8	rw	0	Polarity selection Bit 7: Position POL Bit 6: Velocity POL Bit 5: Torque POL Refer to section 5.10.
60A8h		VAR	SI unit position	U32	rw	0	SI unit position 00000000h (no unit)
60A9h		VAR	SI unit velocity	U32	rw	0	SI unit velocity FEB44700h (0.01 r/min)
2D60h		VAR	Target point table	I16	rw	0	Set next station No. 0 to 254: Positioning operation to specified stations
2D68h		VAR	Point demand value	I16	ro		The currently specified next station No. is returned. While the servo motor is stopped, the value becomes the set value of the Target point table (2D60h).
2D69h		VAR	Point actual value	I16	ro		The completed point table is returned. The previous value is held until the operation completes.

18. EtherCAT COMMUNICATION

Index	Sub	Object	Name	Data Type	Access	Default	Description
2D6Ah		VAR	M code actual value	U8	ro		Fixed to 0
2D6Bh		VAR	Torque limit value2	U16	rw	10000	Torque limit value 2 Unit: 0.1% (rated torque of 100%) Set a torque limit value for when the servo motor is stopped.

Note. In the indexer method, the unit is the command unit [pulse] (a load-side rotation expressed by the number of servo motor resolution pulses).

(2) Details on the OMS bit of Controlword (idx mode)

Bit	Symbol	Description
4	New set-point	The operation starts toward the point table specified with the Target point table (2D60h) when the bit turns on.
5	Direction	0: Station No. decreasing direction 1: Station No. increasing direction
6	Operation mode	0: Rotation direction specifying indexer operation 1: Shortest rotating indexer operation
8	(reserved)	The value at reading is undefined. Set "0" when writing.
9	(reserved)	

(3) Details on the OMS bit of Statusword (idx mode)

Bit	Symbol	Description
10	(reserved)	The value at reading is undefined.
12	Set-point acknowledge	0: Positioning completed (wait for next command) 1: Positioning being executed
13	Following error	0: No following error 1: Following error Judgment condition for Following error When the time set with Following error time out (6066h) has elapsed with the number of droop pulses exceeding the set value of the Following error window (6065h), this bit becomes "1".

(4) idx mode operation sequence
 (a) Rotation direction specifying indexer

POINT

●Be sure to perform a home position return. Executing positioning operation without home position return will trigger [AL. 90 Home position return incomplete warning] and "Controlword bit 4 (New set-point)" will be disabled.

The following timing chart shows that an operation is performed at a stop of the station No. 0 when servo-on.

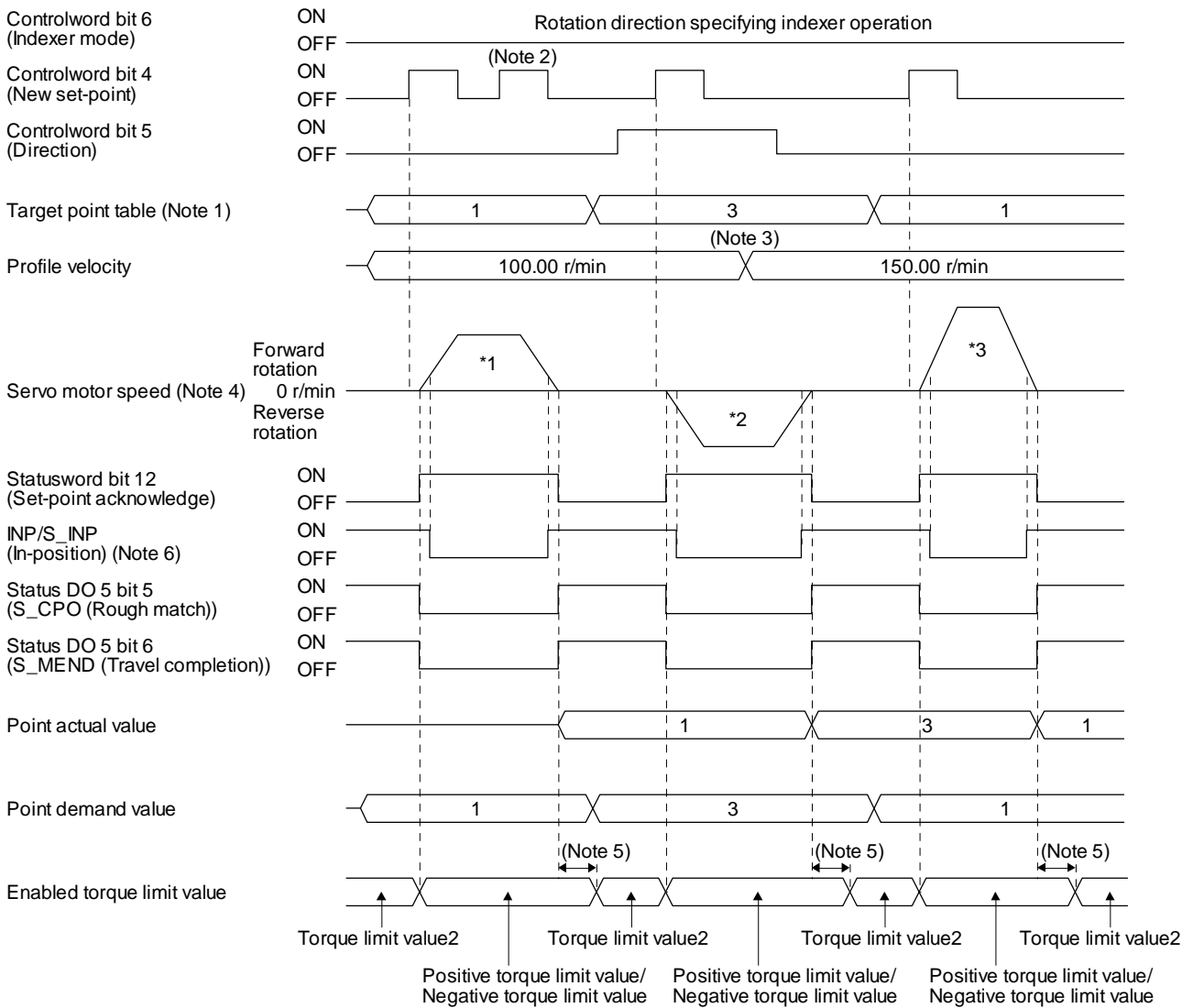

18. EtherCAT COMMUNICATION

- Note
1. When the specified station No. exceeds the value set in [Pr. PT28 Number of stations per rotation] -1, the servo motor does not operate.
 2. "Controlword bit 4 (New set-point)" is not received when the rest of command travel distance is other than "0".
 3. Switching "Profile velocity" during the servo motor rotation does not enable this.
 4. The following shows the operations to be executed.

Operation	*1	*2	*3
Next station No.	No. 1	No. 3	No. 1
Servo motor speed	100.00 r/min	100.00 r/min	150.00 r/min
Positioning			

5. A delay time can be set with [Pr. PT39].
6. After power-on, this turns on if the value is within the in-position range of the corresponding station position.

(b) Shortest rotating indexer

POINT
<ul style="list-style-type: none"> ● Be sure to perform a home position return. Executing positioning operation without home position return will trigger [AL. 90 Home position return incomplete warning] and "Controlword bit 4 (New set-point)" will be disabled. ● When travel distances to a target station position from CCW and from CW are the same, the shaft will rotate to the station No. increasing direction.

This disables "Controlword bit 5 (Direction)". The following timing chart shows that an operation is performed at a stop of the station No. 0 when servo-on.

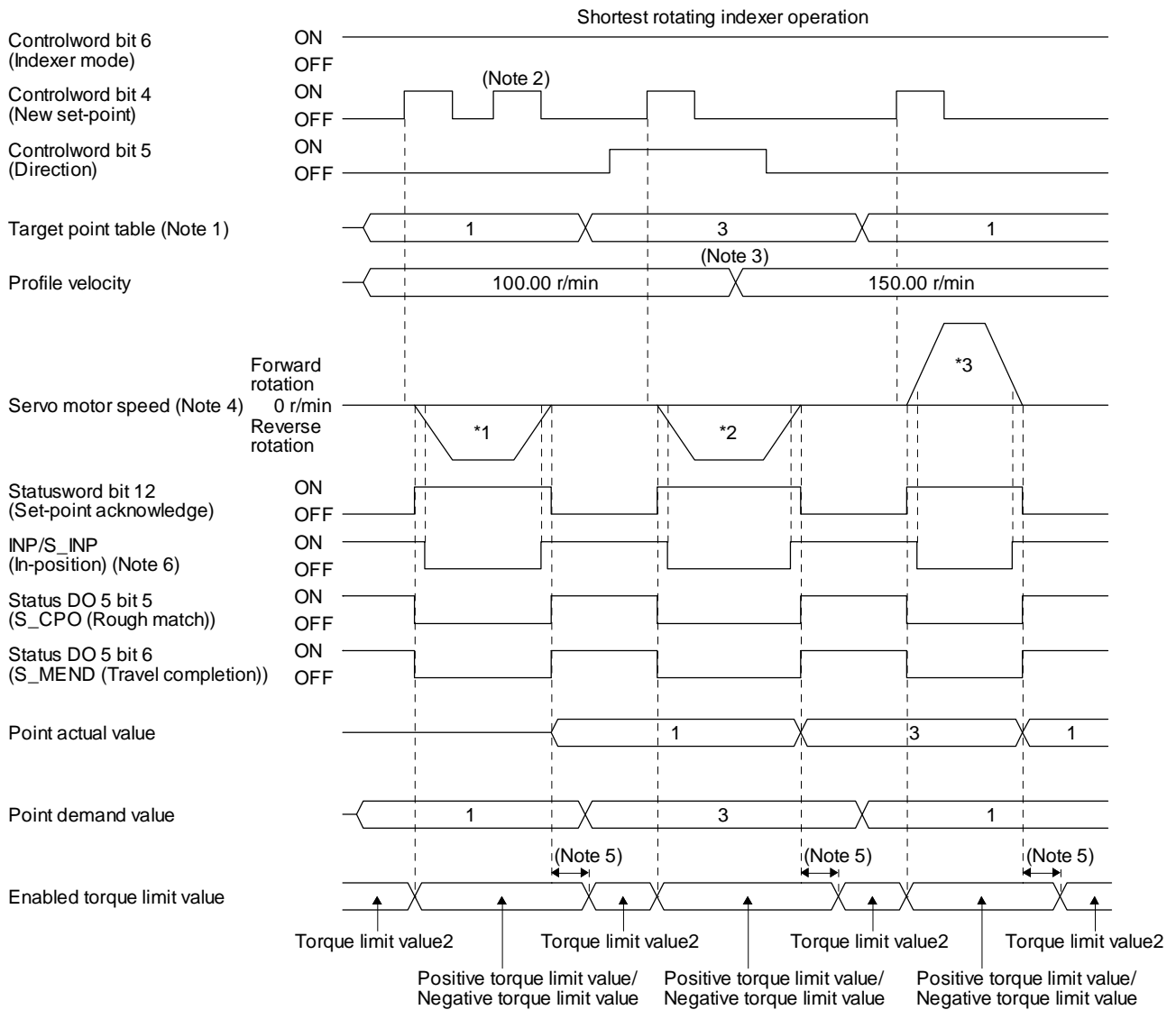

18. EtherCAT COMMUNICATION

- Note
1. When the specified station No. exceeds the value set in [Pr. PT28 Number of stations per rotation] -1, the servo motor does not operate.
 2. "Controlword bit 4 (New set-point)" is not received when the rest of command travel distance is other than "0".
 3. Switching "Profile velocity" during the servo motor rotation does not enable this.
 4. The following shows the operations to be executed.

Operation	*1	*2	*3
Next station No.	No. 1	No. 3	No. 1
Servo motor speed	100.00 r/min	100.00 r/min	150.00 r/min
Positioning			

5. A delay time can be set with [Pr. PT39].
6. After power-on, this turns on if the value is within the in-position range of the corresponding station position.

18. EtherCAT COMMUNICATION

18.5.5 Touch probe

POINT
●The touch probe function cannot be used in the indexer method.

The touch probe function that executes current position latch by sensor input can be used.

With this function, the position feedback of the rising edge and falling edge of TPR1 (touch probe 1) and TPR2 (touch probe 2) or the position feedback of when the encoder zero point was passed through can be stored into each object of 60BAh to 60BDh according to the conditions specified in Touch probe function (60B8h).

The following shows the touch probe detection resolution. Enabling the high precision touch probe will disable the encoder output pulses.

Input terminal		Touch probe1	Touch probe2
Input terminal		TPR1	TPR2
Encoder resolution	[Pr. PD37] = _ _ _ 0 (Selection of high-precision touch probe is disabled)	55 μ s	55 μ s
	[Pr. PD37] = _ _ _ 1 (Selection of high-precision touch probe is enabled)	55 μ s	Rising: 2 μ s Falling: 55 μ s

(1) Related object

Index	Sub	Object	Name	Data Type	Access	Default	Description
60B8h		VAR	Touch probe function	U16	rw		Settings such as enabling/disabling of the touch probe function and trigger conditions
60B9h		VAR	Touch probe status	U16	ro	0	Status information of the touch probe function
60BAh		VAR	Touch probe pos1 pos value	I32	ro	0	Shows the rising edge position of TPR1 (touch probe 1). (Pos units)
60BBh		VAR	Touch probe pos1 neg value	I32	ro	0	Shows the falling edge position of TPR1 (touch probe 1). (Pos units)
60BCh		VAR	Touch probe pos2 pos value	I32	ro	0	Shows the rising edge position of TPR2 (touch probe 2). (Pos units)
60BDh		VAR	Touch probe pos2 neg value	I32	ro	0	Shows the falling edge position of TPR2 (touch probe 2). (Pos units)

(a) Details of Touch probe function (60B8h)

Bit	Definition
0	0: Touch probe 1 disabled 1: Touch probe 1 enabled
1	0: Single trigger mode 1: Continuous trigger mode
2	0: Set input of touch probe 1 as a trigger 1: Set 0 point of the encoder as a trigger
3	(reserved) The value at reading is undefined. Set "0" when writing.
4	0: Stop sampling at the rising edge of touch probe 1 1: Start sampling at the rising edge of touch probe 1 When the input of touch probe 1 is set as a trigger (Bit 2 = 0), the position feedback latched at rising edge of touch probe 1 is stored in Touch probe pos1 pos value (60BAh). When the encoder zero point is set as a trigger (Bit 2 = 1), the position feedback of when the encoder zero point was passed through is stored in Touch probe pos1 pos value (60BAh).
5	0: Stop sampling at the falling edge of touch probe 1 1: Start sampling at the falling edge of touch probe 1 When the input of touch probe 1 is set as a trigger (Bit 2 = 0), the position feedback latched at falling edge of touch probe 1 is stored in Touch probe pos1 neg value (60BBh). When the encoder zero point is set as a trigger (Bit 2 = 1), the position feedback of when the encoder zero point was passed through is stored in Touch probe pos1 neg value (60BBh).
6	(reserved) The value at reading is undefined. Set "0" when writing.
7	
8	0: Touch probe 2 disabled 1: Touch probe 2 enabled
9	0: Single trigger mode 1: Continuous trigger mode
10	0: Set input of touch probe 2 as a trigger 1: Set 0 point of the encoder as a trigger
11	(reserved) The value at reading is undefined. Set "0" when writing.
12	0: Stop sampling at the rising edge of touch probe 2 1: Start sampling at the rising edge of touch probe 2 When the input of touch probe 2 is set as a trigger (Bit 10 = 0), the position feedback latched at rising edge of touch probe 2 is stored in Touch probe pos2 pos value (60BCh). When the encoder zero point is set as a trigger (Bit 10 = 1), the position feedback of when the encoder zero point was passed through is stored in Touch probe pos2 pos value (60BCh).
13	0: Stop sampling at the falling edge of touch probe 2 1: Start sampling at the falling edge of touch probe 2 When the input of touch probe 2 is set as a trigger (Bit 10 = 0), the position feedback latched at falling edge of touch probe 2 is stored in Touch probe pos2 neg value (60BDh). When the encoder zero point is set as a trigger (Bit 10 = 1), the position feedback of when the encoder zero point was passed through is stored in Touch probe pos2 neg value (60BDh).
14	(reserved) The value at reading is undefined. Set "0" when writing.
15	

(b) Details of Touch probe status (60B9h)

Bit	Definition
0	0: Touch probe 1 disabled 1: Touch probe 1 enabled
1	0: The rising edge position of touch probe 1 has not been stored. 1: The rising edge position of touch probe 1 has been stored. When the position feedback is stored in Touch probe pos1 pos value (60BAh), this bit becomes "1". When "0" is set in the bit 4 of Touch probe function (60B8h), this bit becomes "0".
2	0: The falling edge position of touch probe 1 has not been stored. 1: The falling edge position of touch probe 1 has been stored. When the position feedback is stored in Touch probe pos1 neg value (60BBh), this bit becomes "1". When "0" is set in the bit 5 of Touch probe function (60B8h), this bit becomes "0".
3	(reserved) The value at reading is undefined. Set "0" when writing.
4	
5	
6	
7	
8	0: Touch probe 2 disabled 1: Touch probe 2 enabled
9	0: The rising edge position of touch probe 2 has not been stored. 1: The rising edge position of touch probe 2 has been stored. When the position feedback is stored in Touch probe pos2 pos value (60BCh), this bit becomes "1". When "0" is set in the bit 12 of Touch probe function (60B8h), this bit becomes "0".
10	0: The falling edge position of touch probe 2 has not been stored. 1: The falling edge position of touch probe 2 has been stored. When the position feedback is stored in Touch probe pos2 neg value (60BDh), this bit becomes "1". When "0" is set in the bit 13 of Touch probe function (60B8h), this bit becomes "0".
11	(reserved) The value at reading is undefined. Set "0" when writing.
12	
13	
14	
15	

(2) Timing chart

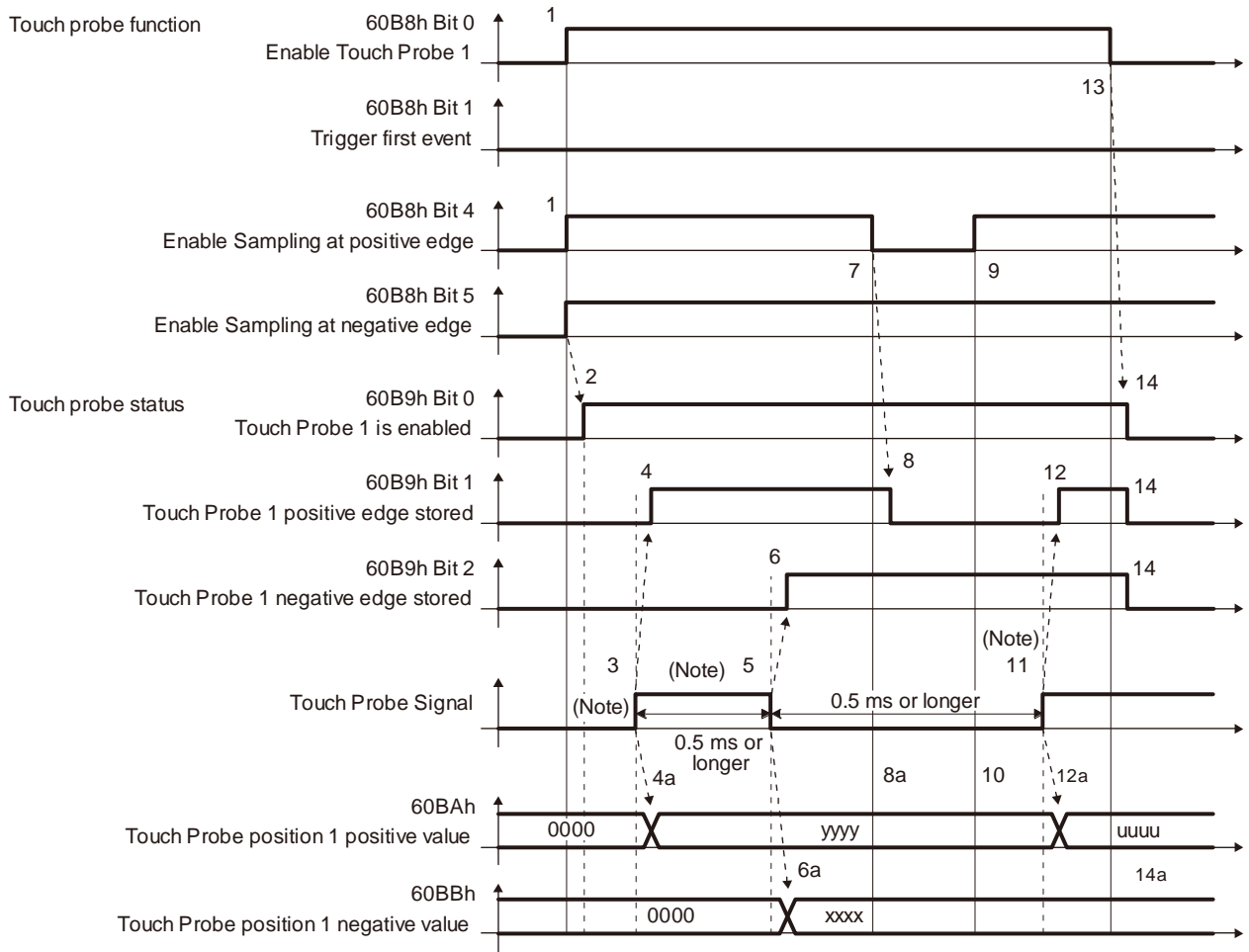

Note.	Turn on and off Touch Probe Signal so that both the on time and off time are 0.5 ms or longer.
-------	--

Transition No.	Object	Description
1	60B8h Bit 0, 4, 5 = 1	Enables Touch Probe1. The rising edge and falling edge are enabled.
2	→ 60B9h Bit 0 = 1	Turns on the Touch Probe1 enable status.
3		Turns on Touch Probe Signal (TPR1).
4	→ 60B9h Bit 1 = 1	Turns on the Touch Probe1 positive edge stored status.
4a	→ 60BAh	Sets the latched position feedback for Touch probe position1 positive value.
5		Turns off Touch Probe Signal (TPR1).
6	→ 60B9h Bit 2 = 1	Turns on the Touch Probe1 negative edge stored status.
6a	→ 60BBh	Sets the latched position feedback for Touch probe position1 negative value.
7	60B8h Bit 4 = 0	Turns off Sample positive edge. Rising edge detection is disabled.
8	→ 60B9h Bit 1 = 0	Turns off Touch Probe1 positive edge stored status.
8a	→ 60BAh	Touch probe position1 positive value does not change.
9	60B8h Bit 4 = 1	Turns on Sample positive edge. Rising edge detection is enabled.
10	→ 60BAh	Touch probe position1 positive value does not change.
11		Turns on Touch Probe Signal (TPR1).
12	→ 60B9h Bit 1 = 1	Turns on the Touch Probe1 negative edge stored status.
12a	→ 60BAh	Sets the latched position feedback for Touch probe position1 negative value.
13	60B8h Bit 0 = 0	Disables Touch Probe1.
14	→ 60B9h Bit 0, 1, 2 = 0	Clears all the status Bit.
14a	→ 60BAh, 60BBh	Touch probe position1 positive/negative value does not change.

18. EtherCAT COMMUNICATION

(3) High-precision touch probe

TPR2 (touch probe 2) supports high-precision touch probe. The normal touch probe has the latch function with precision of 55 μ s. On the other hand, the high-precision touch probe latches precisely startup of TPR2 (touch probe 2) with precision of 2 μ s. To use the high-precision touch probe, set [Pr. PD37] to " _ _ _ 1". While the high-precision touch probe is being used, the encoder pulse output function cannot be used. The precision of falling edge is 55 μ s in this case as well.

18.5.6 Quick stop

Decelerate the servo motor to a stop with the Quick stop command of Controlword (6040h). The following table shows the related objects.

Index	Sub	Object	Name	Data Type	Access	Default	Description
6085h		VAR	Quick stop deceleration	U32	rw	100	Deceleration at deceleration to a stop by Quick stop Unit: ms
605Ah		VAR	Quick stop option code	I16	rw	2	Refer to table 5.2 for details.

The operation method of deceleration to a stop can be specified with Quick stop option code (605Ah). The following table shows the supported methods and the operations.

Table 5.2 Quick stop option code

Setting value	Description
1 (Not supported) (Note)	csp/csv: The servo motor decelerates to a stop with Quick stop deceleration (6085h) and the state shifts to the Switch On Disabled state. cst/tq: The state immediately shifts to the Switch on disabled state and the servo motor is stopped with the dynamic brake. pp/pv: The servo motor decelerates to a stop with Profile deceleration (6084h) and the state shifts to the Switch On Disabled state. hm: The servo motor decelerates to a stop with Homing acceleration (609Ah) and the state shifts to the Switch On Disabled state.
2	In the cyclic synchronous mode (csp/csv), profile mode (pp/pv), homing mode (hm), point table mode (pt), Jog mode (jg) and indexer mode (idx), the servo motor decelerates to a stop with Quick stop deceleration (6085h) and the state shifts to the Switch On Disabled. In the cyclic synchronous torque mode (cst) and profile torque mode (tq), the state immediately shifts to the Switch On Disabled state and the servo motor stops with the dynamic brake.
3 (Not supported) (Note)	The current is limited and the servo motor decelerates to a stop. Then, the state shifts to the Switch On Disabled state.
4 (Not supported) (Note)	The voltage is limited and the servo motor decelerates to a stop. Then, the state shifts to the Switch On Disabled state.
5 (Not supported) (Note)	The servo motor decelerates to a stop. The state does not change from the Quick Stop Active state (servo-on).
6 (Not supported) (Note)	The servo motor decelerates to a stop with Quick stop deceleration (6085h). The state does not change from the Quick Stop Active state (servo-on).
7 (Not supported) (Note)	The current is limited and the servo motor decelerates to a stop. The state does not change from the Quick Stop Active state (servo-on).
8 (Not supported) (Note)	The voltage is limited and the servo motor decelerates to a stop. The state does not change from the Quick Stop Active state (servo-on).

Note. This is not supported by the driver.

18. EtherCAT COMMUNICATION

18.5.7 Halt

When Halt Bit (Bit 8 of Controlword) is set to 1, the servo motor decelerates to a stop with the deceleration time constant of Homing acceleration (609Ah), Profile deceleration (6084h) or the point table according to the setting of Halt option code (605Dh). This function can be used in profile mode, homing mode (hm) and point table method (pt/jg). Operation in other modes can be performed regardless of the Halt Bit status.

When Halt Bit is set to 0 at deceleration stop operation, the servo motor decelerates to a stop and returns to the operable state. The following table shows the related object.

Index	Sub	Object	Name	Data Type	Access	Default	Description
605Dh		VAR	Halt option code	I16	rw	1	Setting for executing the Halt function Refer to table 5.3 for details.

The following table shows descriptions of Halt option code (605Dh). However, in the profile torque mode (tq), Torque demand value (6074h) is set to 0 regardless of Halt option code (605Dh). The amount of torque change at this time can be set using Torque slope (6087h).

Table 5.3 Halt option code

Setting value	Description
1	pp/pv/jg: The servo motor decelerates to a stop with Profile deceleration (6084h), and the state does not change from Operation Enabled (servo-on). hm: The servo motor decelerates to a stop with Homing acceleration (609Ah), and the state does not change from Operation Enabled (servo-on). pt: The servo motor decelerates to a stop with the deceleration time constant set in the point tables, and the state does not change from Operation Enabled (servo-on).
2 (Not supported) (Note)	The servo motor decelerates to a stop with Quick stop deceleration (6085h). The state does not change from the Operation Enabled state (servo-on).
3 (Not supported) (Note)	The current is limited and the servo motor decelerates to a stop. The state does not change from the Operation Enabled (servo-on).
4 (Not supported) (Note)	The voltage is limited and the servo motor decelerates to a stop. The state does not change from the Operation Enabled (servo-on).

Note. This is not supported by the driver.

18.5.8 Software position limit

Specify the upper and lower limits of the command position and current position. If a command position exceeding the limit position is specified, the command position is clamped at the limit position. Specify a relative position from the machine home point (position address = 0) as the limit position.

This function is enabled when the home position is not erased in the cyclic synchronous position mode (csp), profile position mode (pp), point table mode (pt) or Jog mode (jg). While the clamp processing is being performed with the command position exceeding the limit value, [AL. 98 Software limit warning] occurs and not cleared. When the position command of the direction opposite to reached Software position limit (607Dh) is given, the operation can be restarted.

In the cyclic synchronous position mode (csp), stop a command when the software position limit is detected. When the command position exceeds 32 bits (-2147483648 to 2147483647), [AL. 69 Command error] occurs. When the command position exceeds the limit range by 30 bits (-536870912 to 536870911), [AL. 69 Command error] also occurs.

When [AL. 69 Command error] has occurred, the home position is erased. Perform a home position return again. The following table lists the related objects.

Index	Sub	Object	Name	Data Type	Access	Default	Description
607Dh	0	ARRAY	Software position limit	U8	ro	2	Number of entries
	1		Min position limit (Note)	I32	rw	0	Specify a relative position from the machine home point (position address = 0) as the minimum value of the command position and current position. When the value falls below the minimum value, it is clamped and processed as the minimum value.
	2		Max position limit (Note)	I32	rw	0	Specify a relative position from the machine home point (position address = 0) as the maximum value of the command position and current position. When the value exceeds the maximum value, it is clamped and processed as the maximum value.

Note: When the set value of Min position limit is equal to or greater than the set value of Max position limit, the function of Software position limit (607Dh) is disabled.

18.5.9 Torque limit

Generated torque can be limited with the values of Positive torque limit value (60E0h) and Negative torque limit value (60E1h). When "0" is set, torque () is not generated. The following table lists the related objects.

Index	Sub	Object	Name	Data Type	Access	Default	Description
60E0h		VAR	Positive torque limit value	U16	rw	10000	[Pr. PA11 Forward rotation torque limit/positive direction limit] Torque limit value in CCW power running/CW regeneration Unit: 0.1% (rated torque of 100%) Range: 0 to 10000
60E1h		VAR	Negative torque limit value	U16	rw	10000	[Pr. PA12 Reverse rotation torque limit/negative direction limit] Torque limit value in CW power running/CCW regeneration Unit: 0.1% (rated torque of 100%) Range: 0 to 10000

18. EtherCAT COMMUNICATION

18.5.10 Polarity

The rotation direction of a servo motor to position commands, speed commands, and torque commands can be set with Polarity (607Eh). For the Polarity (607Eh) setting to position commands and speed commands, use [Pr. PA14]. For the Polarity (607Eh) setting to torque commands, use [Pr. PA14] and "POL reflection selection at torque mode" of [Pr. PC29]. A change in the setting of Polarity (607Eh) is not applied without enabling the change. Refer to section 6.5.2 for the procedure of enabling parameters.

(1) Object definition

Bit	Description
0	(reserved) The value at reading is undefined. Set "0" at writing.
1	
2	
3	
4	
5	Torque POL The polarity is reversed when this bit is turned on.
6	Velocity POL The polarity is reversed when this bit is turned on.
7	Position POL The polarity is reversed when this bit is turned on.

(2) Target object

The following shows objects whose polarity is reversed according to the setting of Polarity (607Eh).

Object name (Index)	Remark
Target position (607Ah)	
Target velocity (60FFh)	
Target torque (6071h)	
Position actual value (6064h)	
Velocity demand value (606Bh)	Whether to reverse the polarity using Polarity (607Eh) can be switched with "Internal command speed POL reflection selection" of [Pr. PC76]. [Pr. PC76] = _ 0 _ _ (Automatic setting): Automatically set depending on the type of the network in use. [Pr. PC76] = _ 1 _ _ (POL setting enabled): The polarity is reversed using Polarity. [Pr. PC76] = _ 2 _ _ (POL setting disabled): The polarity is not reversed using Polarity.
Velocity actual value (606Ch)	
Torque demand (6074h)	
Torque actual value (6077h)	
Positive torque limit value (60E0h)	The corresponding parameters are changed according to "POL reflection selection at torque mode" in [Pr. PA14] and [Pr. PC29] as follows. [Pr. PA14] = 0, [Pr. PC29] = 1 _ _ _ (Disabled): Written to [Pr. PA11 Forward rotation torque limit/positive direction limit]. [Pr. PA14] = 1, [Pr. PC29] = 1 _ _ _ (Disabled): Written to [Pr. PA11 Forward rotation torque limit/positive direction limit]. [Pr. PA14] = 0, [Pr. PC29] = 0 _ _ _ (Enabled): Written to [Pr. PA11 Forward rotation torque limit/positive direction limit]. [Pr. PA14] = 1, [Pr. PC29] = 0 _ _ _ (Enabled): Written to [Pr. PA12 Reverse rotation torque limit/negative direction limit].
Negative torque limit value (60E1h)	The corresponding parameters are changed according to "POL reflection selection at torque mode" in [Pr. PA14] and [Pr. PC29] as follows. [Pr. PA14] = 0, [Pr. PC29] = 1 _ _ _ (Disabled): Written to [Pr. PA12 Reverse rotation torque limit/negative direction limit]. [Pr. PA14] = 1, [Pr. PC29] = 1 _ _ _ (Disabled): Written to [Pr. PA12 Reverse rotation torque limit/negative direction limit]. [Pr. PA14] = 0, [Pr. PC29] = 0 _ _ _ (Enabled): Written to [Pr. PA12 Reverse rotation torque limit/negative direction limit]. [Pr. PA14] = 1, [Pr. PC29] = 0 _ _ _ (Enabled): Written to [Pr. PA11 Forward rotation torque limit/positive direction limit].
Digital inputs (60FDh)	The corresponding status is changed according to the setting of [Pr. PA14] as follows. [Pr. PA14] = 0: The status of LSN (reverse rotation stroke end) is applied to Negative limit switch (bit 0). The status of LSP (forward rotation stroke end) is applied to Positive limit switch (bit 1). [Pr. PA14] = 1: The status of LSP (forward rotation stroke end) is applied to Negative limit switch (bit 0). The status of LSN (reverse rotation stroke end) is applied to Positive limit switch (bit 1).

18. EtherCAT COMMUNICATION

18.5.11 Degree function

(1) Summary

Selecting "degree (_ 2 _)" in "Position data unit" of [Pr. PT01] allows for positioning with card coordinates (axis of rotation). The following shows the differences when "degree" is selected.

Item	Description
Target position (607Ah)	The range will be -360.000° to 360.000°.
Position actual value (6064h)	The range will be 0° to 359.999°.
Software position limit (607Dh)	The range will be 0° to 359.999°. A value outside the range is clamped within the range 0° to 359.999°.
Position range limit (607Bh)	The range will be 0° to 359.999°.
Touch probe pos1 pos value (60BAh)	The range will be 0° to 359.999°.
Touch probe pos1 neg value (60BBh)	The range will be 0° to 359.999°.
Touch probe pos2 pos value (60BCh)	The range will be 0° to 359.999°.
Touch probe pos2 neg value (60BDh)	The range will be 0° to 359.999°.
Home offset (607Ch)	The range will be 0° to 359.999°.
Current position (2B2Fh)	The range will be 0° to 359.999°.
Command position (2B30h)	The range will be 0° to 359.999°.
Command remaining distance (2B31h)	The range will be 0° to 359.999°.
Alarm Monitor 47 Current position (2BAFh)	The range will be 0° to 359.999°.
Alarm Monitor 48 Command position (2BB0h)	The range will be 0° to 359.999°.
Alarm Monitor 49 Command remaining distance (2BB1h)	The range will be 0° to 359.999°.
Position range output address ([Pr. PT19] to [Pr. PT22])	The range will be 0° to 359.999°. When a value outside the range is set, the value will be clamped within the range 0° to 359.999°.

(2) Setting of the operation pattern

Positioning operation patterns can be changed with Positioning option code (60F2h) or [Pr. PT03].

Change the setting while the servo motor is stopped (Target reached is on). If the setting is changed while the servo motor is rotating (Target reached is off), the setting value is not applied immediately. The new value is applied at a positioning start (Bit 4 of Controlword is turned on) after Target reached is once turned on. The following table shows the bit of Positioning option code (60F2h) and the setting of [Pr. PT03].

Bit 7	Bit 6	[Pr. PT03]	Rotation direction definition for the axis of rotation
0	0	_ 0 _ _	The servo motor rotates to the target position in a direction specified with a sign of the position data.
0	1	_ 2 _ _	The servo motor rotates in the address decreasing direction regardless of the sign of the position data.
1	0	_ 3 _ _	The servo motor rotates in the address increasing direction regardless of the sign of the position data.
1	1	_ 1 _ _	The servo motor rotates from the current position to the target position in the shorter direction. If the distances from the current position to the target position are the same for CCW and CW, the servo motor rotates in the CCW direction.

(3) Sequence

The following shows the operation patterns corresponding to the settings of Positioning option code (60F2h).

(a) When POL is disabled ([Pr. PA14] = 0)

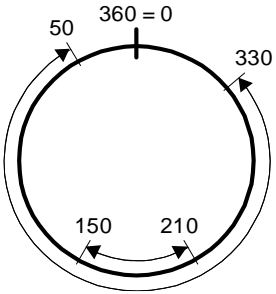
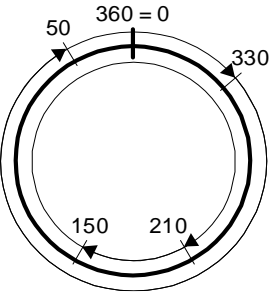
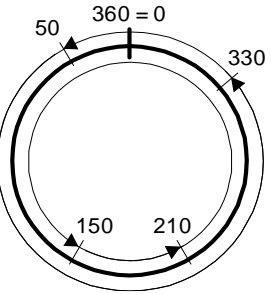
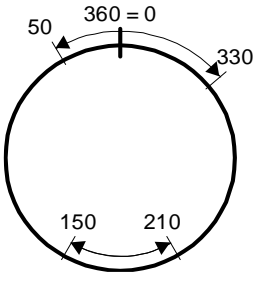
			
<p>Bit 7: 0 Bit 6: 0</p> <p>The servo motor rotates in a direction specified with a sign of the position data.</p>	<p>Bit 7: 0 Bit 6: 1</p> <p>The servo motor rotates only in the address decreasing direction.</p>	<p>Bit 7: 1 Bit 6: 0</p> <p>The servo motor rotates only in the address increasing direction.</p>	<p>Bit 7: 1 Bit 6: 1</p> <p>The servo motor rotates in the shorter direction.</p>

(b) When POL is enabled ([Pr. PA14] = 1)

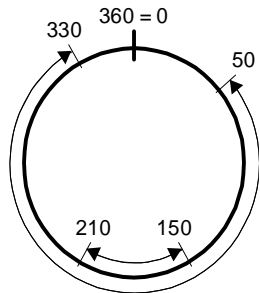
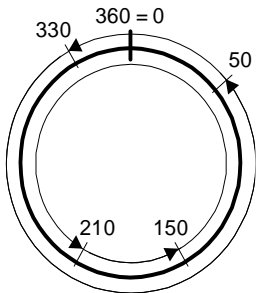
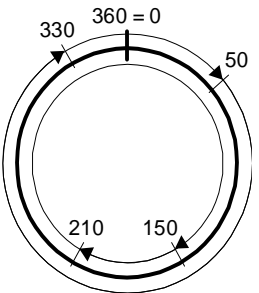
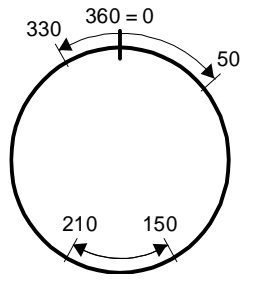
			
<p>Bit 7: 0 Bit 6: 0</p> <p>The servo motor rotates in a direction specified with a sign of the position data.</p>	<p>Bit 7: 0 Bit 6: 1</p> <p>The servo motor rotates only in the address decreasing direction.</p>	<p>Bit 7: 1 Bit 6: 0</p> <p>The servo motor rotates only in the address increasing direction.</p>	<p>Bit 7: 1 Bit 6: 1</p> <p>The servo motor rotates in the shorter direction.</p>

18.5.12 Torque offset

POINT
<ul style="list-style-type: none"> ●. ●Torque changes steeply depending on the set value in the Torque offset (60B2h) when the cyclic synchronous mode (csp/csv/cst) switches to the homing mode (hm), and this may rotate the servo motor. Check the set value in the Torque offset (60B2h) when switching. ●Torque changes steeply depending on the set value in the Torque offset (60B2h) when servo-on, and this may rotate the servo motor. Check the set value in the Torque offset (60B2h) when switching. ●Torque offset (60B2h) can be used with [Pr. PE47 Torque offset]. When other than "0" is set to both the parameter and the object, both of the set values in the Torque offset (60B2h) and [Pr. PE47 Torque offset] are added to the torque command. ●In the test operation mode, the Torque offset (60B2h) is disabled.

(1) Summary

This function compensates the torque command with the set value in the Torque offset (60B2h). This function will be enabled in the cyclic synchronous mode (csp/csv/cst). The set values will be disabled in the other control modes.

(2) Usage

- (a) Set "_ _ _ 0" or "_ _ _ 1" in [Pr. PA01] and cycle the power of the driver.
- (b) Switch the control mode to csp, csv or cst in the Modes of operation (6060h) after the state shifts to Operational.
- (c) Set a value in Torque offset (60B2h).

(3) Monitor data

The following monitor data shows the values to which the set values in Torque offset (60B2h) are added.

Item	Monitor data
Object	Effective load ratio (2B09h)
	Peak load ratio (2B0Ah)
	Instantaneous torque (2B0Bh)
	Alarm Monitor 9 Effective load ratio (2B89h)
	Alarm Monitor 10 Peak load ratio (2B8Ah)
	Alarm Monitor 11 Instantaneous torque (2B8Bh)
	Torque demand value (6074h)
	Torque actual value (6077h)
Setup software (MR Configurator2™)	"Monitor" - "Display All" - "Instantaneous torque"
	"Monitor" - "Display All" - "Effective load ratio"
	"Monitor" - "Display All" - "Peak load ratio"
	"Monitor" - "Graph" - "Torque"
	"Monitor" - "Graph" - "Curr. cmd."
	"Monitor" - "Graph" - "Torque equivalent to disturbance"
	"Monitor" - "Graph" - "Torque cmd."
	"Monitor" - "Graph" - "Effective load ratio"
	Analog monitor output voltage 1
	Analog monitor output voltage 2
Output signal	Torque monitor of the analog monitor

18. EtherCAT COMMUNICATION

18.6 MANUFACTURER FUNCTIONS

18.6.1 Object for status monitor

The monitor data as the manufacturer functions can be checked with the objects in the following table.

Index	Sub	Object	Name	Data Type	Access	Default	Description
2B0 1h		VAR	Monitor 1 Cumulative feedback pulses	I32	rw		Cumulative feedback pulses (Unit: pulse) Cleared by writing "00001EA5h".
2B0 2h		VAR	Monitor 2 Servo motor speed	I32	ro		Servo motor speed (Unit: r/min)
2B0 3h		VAR	Monitor 3 Droop pulse	I32	ro		Droop pulses (Unit: pulse)
2B0 4h		VAR	Monitor 4 Cumulative command pulses	I32	ro		Cumulative command pulses (Unit: pulse) Cleared by writing "00001EA5h".
2B0 5h		VAR	Monitor 5 Command pulse frequency	I32	ro		Command pulse frequency (Unit: kpulse/s)
2B0 8h		VAR	Monitor 8 Regenerative load ratio	U16	ro		Regenerative load ratio (Unit: %)
2B0 9h		VAR	Monitor 9 Effective load ratio	U16	ro		Effective load ratio (Unit: %)
2B0 Ah		VAR	Monitor 10 Peak load ratio	U16	ro		Peak load ratio (Unit: %)
2B0 Bh		VAR	Monitor 11 Instantaneous torque	I16	ro		Instantaneous torque (Unit: %)
2B0 Ch		VAR	Monitor 12 Within one-revolution position	I32	ro		Position within one-revolution (Unit: pulse)
2B0 Dh		VAR	Monitor 13 ABS counter	I32	ro		ABS counter (Unit: rev)
2B0 Eh		VAR	Monitor 14 Load to motor inertia ratio	U16	ro		Load to motor inertia ratio (Unit: 0.01 times)
2B0 Fh		VAR	Monitor 15 Bus voltage	U16	ro		Bus voltage (Unit: V)
2B1 0h		VAR	Monitor 16 Load side encoder cumulative feedback pulses	I32	ro		Load-side encoder cumulative feedback pulses (Unit: pulse)
2B1 1h		VAR	Monitor 17 Load side encoder droop pulses	I32	ro		Load-side encoder droop pulses (Unit: pulse)
2B1 2h		VAR	Monitor 18 Load side encoder information 1	I32	ro		Load-side encoder information 1 (Unit: pulse)
2B1 3h		VAR	Monitor 19 Load side encoder information 2	I32	ro		Load-side encoder information 2 (Unit: rev)
2B1 7h		VAR	Monitor 23 Temperature of motor thermistor	I16	ro		Temperature of servo motor thermistor (Unit: °C)
2B1 8h		VAR	Monitor 24 Motor side cumulative F/B pulses (Before Gear)	I32	ro		Servo motor-side cumulative feedback pulses (before gear) (Unit: pulse)
2B1 9h		VAR	Monitor 25 Electrical angle	I32	ro		Electrical angle (Unit: pulse)
2B2 3h		VAR	Monitor 35 Motor/load side position deviation	I32	ro		Servo motor-side/load-side position deviation (Unit: pulse)
2B2 4h		VAR	Monitor 36 Motor/load side speed deviation	I32	ro		Servo motor-side/load-side speed deviation (Unit: r/min)

18. EtherCAT COMMUNICATION

Index	Sub	Object	Name	Data Type	Access	Default	Description
2B25h		VAR	Monitor 37 Internal temperature of encoder	I16	ro		Internal temperature of encoder (Unit: °C)
2B26h		VAR	Monitor 38 Settling time	I16	ro		Settling time (Unit: ms)
2B27h		VAR	Monitor 39 Oscillation detection frequency	I16	ro		Oscillation detection frequency (Unit: Hz)
2B28h		VAR	Monitor 40 Number of tough drive operations	U32	ro		Number of tough drive operations (Unit: time)
2B2Dh		VAR	Monitor 45 Unit power consumption	I16	ro		Unit power consumption (Unit: W)
2B2Eh		VAR	Monitor 46 Unit total power consumption	I32	ro		Unit total power consumption (Unit: Wh)
2B2Fh (Note 1)		VAR	Monitor 47 Current position	I32	ro		Current position (Note 2) (Unit: pos units)
2B30h (Note 1)		VAR	Monitor 48 Command position	I32	ro		Command position (Note 2) (Unit: pos units)
2B31h (Note 1)		VAR	Monitor 49 Remaining command distance	I32	ro		Command remaining distance (Note 3) (Unit: pos units)
2B32h (Note 1)		VAR	Monitor 50 Point table No./Program No./Station position No.	I16	ro		Point table/program No./command station position (Note 3) (Unit: none)
2	In the indexer method, the value is fixed to 0.						
3	This is available in the point table method and the indexer method. The value is fixed to 0 in the other control modes.						

18. EtherCAT COMMUNICATION

18.6.2 Incremental counter

To protect the operation when a PDO communication error occurs, the incremental counter can be used in the DC mode. When an incremental counter object has been mapped in the PDO communication, the detection of [AL. 86.2 Network communication error 2] is enabled. Increment the incremental counter (download) on the master (upper side) per communication cycle. When incremental counter objects are mapped to RxPDO and TxPDO, the slave (driver) sends the sum of the received incremental counter value and 1. Detect an incremental counter update error on the master side (upper side) as necessary. The incremental counter value is an unsigned integer from 0 to 255 and added per send/receive of the PDO communication. The value returns to 0 when exceeding 255.

Index	Sub	Object	Name	Data Type	Default	Description
2D23h		VAR	Watch dog counter DL	U8		Incremental counter (download)
2D24h		VAR	Watch dog counter UL	U8		Incremental counter (upload)

18.6.3 Stroke end

When LSP (Forward rotation stroke end) or LSN (Reverse rotation stroke end) is turned off, a slow stop is performed by either of the following stop methods.

In the cyclic synchronous position mode (csp), stop the command when the stroke end is detected. When the command position exceeds by 30 bits from the position where the stroke end is detected, [AL. 69 Command error] occurs.

When [AL. 69 Command error] has occurred, the home position is erased. Perform a home position return again.

Operation status		Remark
During rotation at constant speed	During deceleration to a stop	
<p>— No S-pattern acceleration/ deceleration - - - With S-pattern acceleration/ deceleration</p> <p>Servo motor speed</p> <p>0 r/min (0 mm/s)</p> <p>Part of droop pulses</p> <p>LSP or LSN ON OFF</p>	<p>— No S-pattern acceleration/ deceleration - - - With S-pattern acceleration/ deceleration</p> <p>Servo motor speed</p> <p>0 r/min (0 mm/s)</p> <p>Part of droop pulses</p> <p>LSP or LSN ON OFF</p>	<p>Travels for the droop pulse portion and stops the servo motor.</p> <p>A difference will be generated between the command position and the current position.</p> <p>Perform a home position return again.</p>

Perform a return as follows when the stroke end is detected.

Mode	Return method
Cyclic synchronous position mode (csp)	After following up Target position (607Ah) with Position actual value (6061h), change the direction opposite to the limit. Check that Bit 12 of Statusword (6041h) is 0 before performing the return.
Cyclic synchronous velocity mode (csv)	Input the speed command of the direction opposite to the limit to Target velocity (60FFh). Check that Bit 12 of Statusword (6041h) is 0 before performing the return.
Profile position mode (pp)	Input the position command of the direction opposite to the limit to Target position (607Ah).
Profile velocity mode (pv)	Input the speed command of the direction opposite to the limit to Target velocity (60FFh).
Point table mode (pt)	Perform operation opposite to the limit with the Jog mode (jg).
Jog mode (jg)	Perform operation opposite to the limit with the Jog mode.
Indexer mode (idx)	Perform operation opposite to the limit with the Jog mode (jg).

18. EtherCAT COMMUNICATION

18.6.4 Definition of alarm-related objects

Whether an alarm occurs or not in the slave (driver) can be detected on the master (upper side) with Bit 3 and Bit 7 of Statusword in the PDO communication. The alarm history of the latest alarm and 15 alarms that have occurred can be referred to by acquiring the following related object values in the SDO communication.

Index	Sub	Object	Name	Data Type	Access	Description
2A00h	0	ARRAY	Alarm history newest	U8	ro	Refer to section 7.3.5 (1).
	1		Alarm No.	U32	ro	
	2		Alarm time (Hour)	U32	ro	
2A01h	0	ARRAY	Alarm history 1	U8	ro	Refer to section 7.3.5 (2).
	1		Alarm No.	U32	ro	
	2		Alarm time (Hour)	U32	ro	
:	:	:	:	:	:	
2A0Fh	0	ARRAY	Alarm history 15	U8	ro	Refer to section 7.3.5 (2).
	1		Alarm No.	U32	ro	
	2		Alarm time (Hour)	U32	ro	
2A40h		VAR	Clear alarm history	U16	wo	Refer to section 7.3.5 (3).
2A41h		VAR	Current alarm	U32	ro	Refer to section 7.3.5 (4).
2A44h	0	VAR	Parameter error number	U16	ro	Refer to section 7.3.5 (5).
2A45h	0	ARRAY	Parameter error list	U8	ro	Refer to section 7.3.5 (6).
	1		(No. 1)	U16	ro	
	:		:	:	:	
	16		(No. 16)	U16	ro	

18. EtherCAT COMMUNICATION

18.6.5 Parameter object

18.6.5.1 Definition of parameter objects

The parameter of the driver can be changed on the master (upper side) by writing values to the following objects in the SDO communication. However, once the power supply is shut off, the changed setting is not held at the next startup. To hold the changed setting even after the power supply is shut-off, save the parameter setting value to EEPROM using Store Parameters (1010h).

To change the setting of the parameters where the changes are reflected by cycling the power (parameters whose symbols are preceded by **), change the value of the corresponding object and execute Store Parameters (1010h) before cycling the power. Refer to chapter 5 of "_ Driver Instruction Manual" for "*" of the parameter symbol. The following table lists the related objects.

Index	Sub	Object	Name	Data Type	Access	Description
2001h		VAR	PA01	l32	rw	[Pr. PA_ _] group
:	:	:	:	:	:	
2020h		VAR	PA32	l32	rw	
2081h		VAR	PB01	l32	rw	[Pr. PB_ _] group
:	:	:	:	:	:	
20C0h		VAR	PB64	l32	rw	
2101h		VAR	PC01	l32	rw	[Pr. PC_ _] group
:	:	:	:	:	:	
2150h		VAR	PC80	l32	rw	
2181h		VAR	PD01	l32	rw	[Pr. PD_ _] group
:	:	:	:	:	:	
21B0h		VAR	PD48	l32	rw	
2201h		VAR	PE01	l32	rw	[Pr. PE_ _] group
:	:	:	:	:	:	
2240h		VAR	PE64	l32	rw	
2281h		VAR	PF01	l32	rw	[Pr. PF_ _] group
:	:	:	:	:	:	
22C0h		VAR	PF48	l32	rw	
2401h		VAR	PL01	l32	rw	[Pr. PL_ _] group
:	:	:	:	:	:	
2430h		VAR	PL48	l32	rw	
2481h		VAR	PT01	l32	rw	[Pr. PT_ _] group
:	:	:	:	:	:	
24D0h		VAR	PT80	l32	rw	
2581h		VAR	PN01	l32	rw	[Pr. PN_ _] group
:	:	:	:	:	:	
25A0h		VAR	PN32	l32	rw	

18.6.5.2 Enabling parameters

The parameters whose symbols are preceded by "*" are enabled by the following operations. Refer to chapter 5 in "_ Driver Instruction Manual" for the parameters with "*". Refer to chapter 5 of "_ Driver Instruction Manual" for "*" of the parameter symbol.

(1) Network communication reset

A parameter is enabled when the EtherCAT state shifts from the Operational state to another state. Refer to section 1.4.4 for the procedure of network disconnection.

(2) Enabling a parameter with a parameter enabling object

A parameter is enabled by writing "1EA5h" to User parameter configuration (2D34h). This operation can be performed only when the EtherCAT state is the Pre-Operational state. The parameter enabling processing requires a maximum of about 100 ms. The following table shows the read values of User parameter configuration (2D34h). By checking the read value, the completion of the parameter enabling processing can be checked.

Value	Description
0	Parameter enabling processing is being executed.
1	Parameter enabling processing is not being executed. (The processing is completed.)

18. EtherCAT COMMUNICATION

18. 6. 7 One-touch tuning

POINT
●One-touch tuning via a network is available with drivers

Refer to section 6.2 of "_ Driver Instruction Manual" for one-touch tuning. Using One-touch tuning mode (2D50h) allows one-touch tuning from a upper side.

(1) Related object

Index	Sub	Object	Name	Data Type	Access	Default	Description
2D50h		VAR	One-touch tuning mode	U8	rw	0	One-touch tuning command Setting a value of "1" to "3" starts one-touch tuning. After one-touch tuning is completed, the setting value automatically changes to "0". 0: During one-touch tuning stop 1: Basic mode 2: High mode 3: Low mode
2D51h		VAR	One-touch tuning status	I8	ro	0	One-touch tuning status Regardless of whether one-touch tuning is properly completed or not, the setting value changes to 100% at the completion. Unit: %
2D52h		VAR	One-touch tuning Stop	U16	wo	0	One-touch tuning stop command Writing "1EA5h" stops one-touch tuning. Writing any value other than "1EA5h" causes SDO Abort Code (0609 0030h Value range of parameter exceeded).
2D53h		VAR	One-touch tuning Clear	U16	wo	0	The parameter changed in one-touch tuning can be returned to the value before the change. 0000h: Restores the initial value. 0001h: Restores the value before one-touch tuning. The setting value of the restored parameter is stored to the EEPROM.
2D54h		VAR	One-touch tuning Error Code	U16	ro	0	One-touch tuning error code 0000h: Finished normally C000h: Tuning canceled C001h: Overshoot exceeded C002h: Servo-off during tuning C003h: Control mode error C004h: Time-out C005h: Load to motor inertia ratio misestimated C00Fh: One-touch tuning disabled

(2) Procedure of one-touch tuning via a network

Perform one-touch tuning via a network in the following procedure.

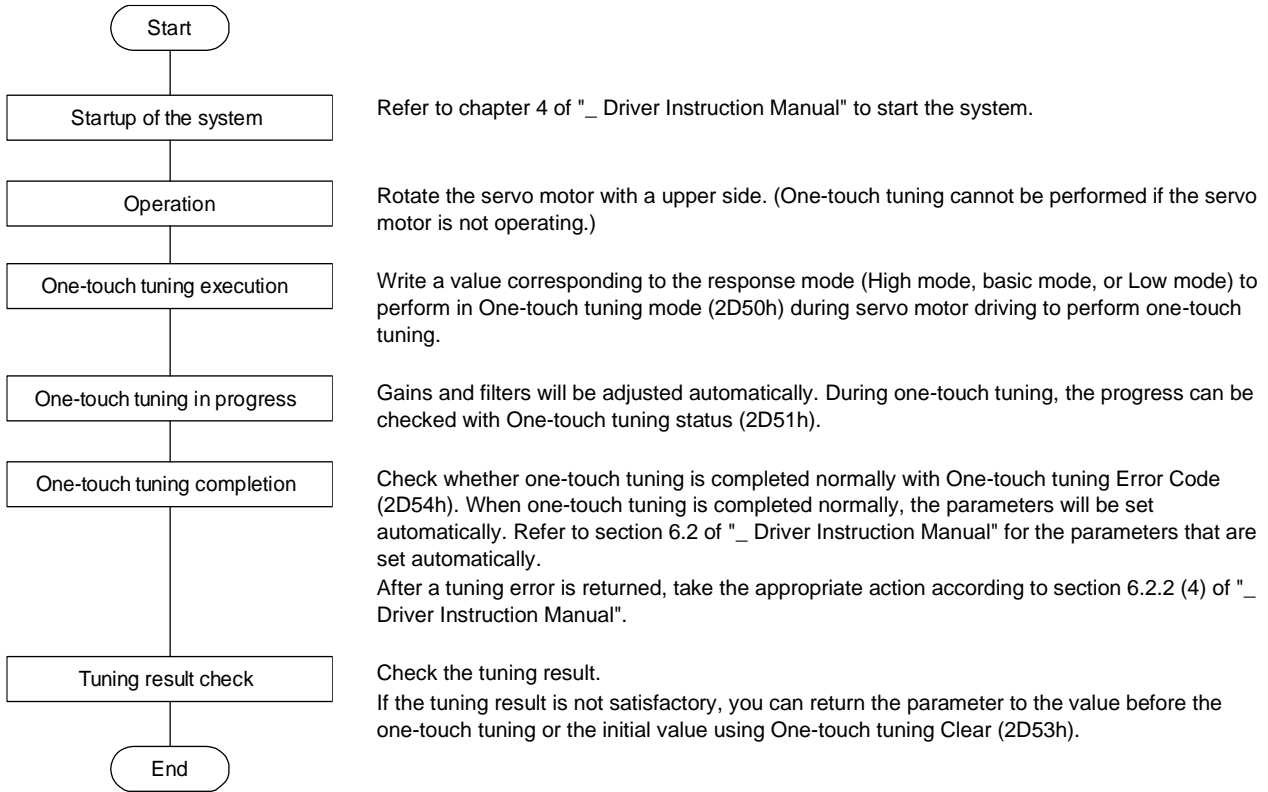

18. EtherCAT COMMUNICATION

18.6.8 Machine diagnosis function

POINT

- The machine diagnosis function via a network is available with drivers

This function estimates the friction and vibrational component of the drive system in the equipment based on the data in the driver, and recognizes an error in the machine parts, including a ball screw and bearing. The information of the machine diagnosis function can be obtained with the following objects.

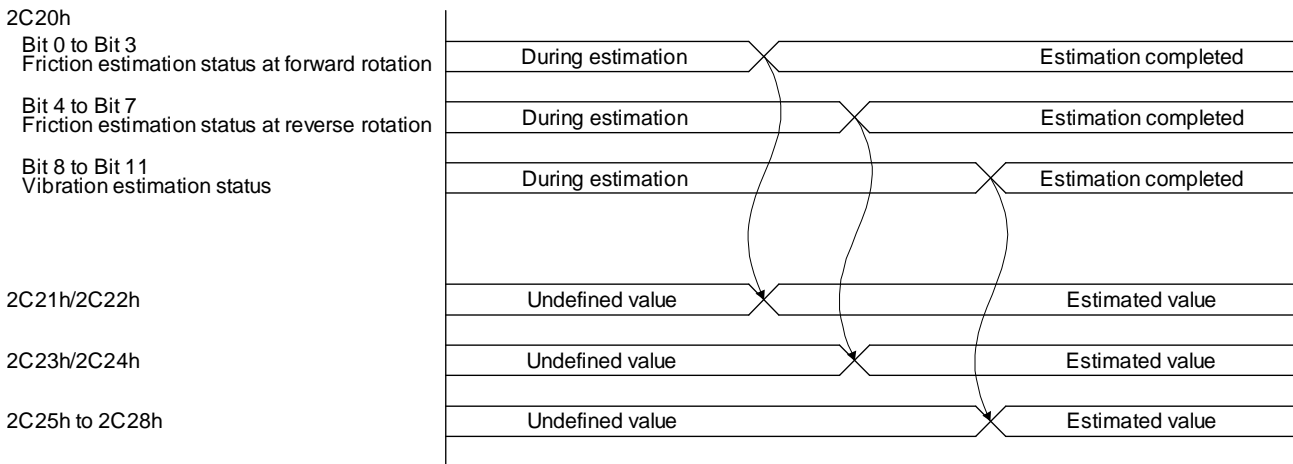

18. EtherCAT COMMUNICATION

Index	Sub	Object	Name	Data Type	Access	Default	Description
2C20h		VAR	Machine diagnostic status	U16	ro		Machine diagnostic status Refer to section 7.3.7 (4).
2C21h		VAR	Static friction torque at forward rotation	I16	ro		Static friction torque at forward rotation Static friction torque at forward rotation is returned in increments of 0.1%.
2C22h		VAR	Dynamic friction torque at forward rotation (at rated speed)	I16	ro		Dynamic friction torque at forward rotation (at rated speed) Dynamic friction torque at forward rotation at the rated speed is returned in increments of 0.1%.
2C23h		VAR	Static friction torque at reverse rotation	I16	ro		Static friction torque at reverse rotation Static friction torque at reverse rotation is returned in increments of 0.1%.
2C24h		VAR	Dynamic friction torque at reverse rotation (at rated speed)	I16	ro		Dynamic friction torque at reverse rotation (at rated speed) Dynamic friction torque at reverse rotation at rated speed is returned in increments of 0.1%.
2C25h		VAR	Oscillation frequency during motor stop	I16	ro		Vibration frequency at stop/servo-lock Vibration frequency during stop/servo-lock is returned in increments of 1 Hz.
2C26h		VAR	Vibration level during motor stop	I16	ro		Vibration level at stop/servo-lock Vibration level during stop/servo-lock is returned in increments of 0.1%.
2C27h		VAR	Oscillation frequency during motor operating	I16	ro		Vibration frequency during operation Vibration frequency during operation is returned in increments of 1 Hz.
2C28h		VAR	Vibration level during motor operating	I16	ro		Vibration level during operation Vibration level during operation is returned in increments of 0.1%.

18. 6. 9 Driver life diagnosis function

POINT
●The driver life diagnosis function via a network is available with drivers

You can check the cumulative energization time and the number of on/off times of the inrush relay based on the data in the driver. This function gives an indication of the replacement time for parts of the driver including a capacitor and a relay before they malfunction. The information of the driver life diagnosis function can be obtained with the following objects.

Index	Sub	Object	Name	Data Type	Access	Default	Description
2C18h		VAR	Power ON cumulative time	U32	ro		The cumulative energization time of the driver is returned.
2C19h		VAR	Number of inrush relay on/off times	U32	ro		The number of on/off times of the inrush relay of the driver is returned.

18.7 OBJECT DICTIONARY

POINT	<p>●In ARRAY data type objects, SubIndex names displayed on the upper side are "SubIndex xxx" (xxx indicates the SubIndex number).</p>
-------	--

18.7.1 Store Parameters

POINT	<p>●Before shutting off the power after executing Store Parameters, always check that parameters are not being saved (bit 0 is on).</p>
-------	---

For the objects that can be saved, write "65766173h" (= reverse order of the ASCII code of "save") to the corresponding sub object of Store Parameters (1010h) to store the object in the EEPROM of the driver. The value saved in the EEPROM is set to the object at the next power-on. For the parameters, the setting can also be changed through the object dictionary. However the new setting is not automatically written to the EEPROM. To write the new setting, use the Store Parameters (1010h). Executing Store Parameters (1010h) takes about a maximum of 25 s because all parameters are written at the same time. Be careful not to shut off the power during writing.

Index	Sub	Object	Name	Data Type	Access	Description
1010h	0	ARRAY	Store Parameters	U8	ro	Number of entries
	1		Save all parameters	U32	rw	Saves all parameters. Writing "save" (= 65766173h) saves all the objects which can be stored in EEPROM.
	2 (Not supported) (Note)		Save communication parameters	U32	rw	Saves communication parameters. Writing "save" (= 65766173h) saves the communication objects (objects in the 1000 s) in EEPROM.
	3 (Not supported) (Note)		Save application parameters	U32	rw	Saves application parameters. Writing "save" (= 65766173h) saves the objects which can be saved in EEPROM except for the communication objects (objects in the 1000 s).

Note. This is not supported by the driver.

The following values are read from this object. When a parameter is being saved, "0" is read. When no parameter is being saved, "1" is read.

Bit	Description
0	0: The parameter cannot be saved with the command. (A parameter is being saved.) 1: The parameter can be saved with the command. (No parameter is being saved.)
1	0: The parameter is not automatically saved.

18. EtherCAT COMMUNICATION

18.7.2 Supported object dictionary list

Group	Name	Index
General Objects	Device Type	1000h
	Error Register	1001h
	Pre-defined error field	1003h
	Manufacturer Device Name	1008h
	Manufacturer Hardware Version	1009h
	Manufacturer Software Version	100Ah
	Store parameters	1010h
	Restore default parameters	1011h
	Identity Object	1018h
	Error Settings	10F1h
PDO Mapping Objects	Receive PDO Mapping	1600h to 1603h
	Transmit PDO Mapping	1A00h to 1A03h
Sync Manager Communication Objects	Sync Manager Communication Type	1C00h
	Sync Manager RxPDO assign	1C12h
	Sync Manager TxPDO assign	1C13h
	SM output parameter	1C32h
	SM input parameter	1C33h
Parameter Objects	PA_ _	2001h to 2020h
	PB_ _	2081h to 20C0h
	PC_ _	2101h to 2150h
	PD_ _	2181h to 21B0h
	PE_ _	2201h to 2240h
	PF_ _	2281h to 22C0h
	PL_ _	2401h to 2430h
	PT_ _	2481h to 24D0h
PN_ _	2581h to 25A0h	
Alarm Objects	Alarm history newest	2A00h
	Alarm history _	2A01h to 2A0Fh
	Clear alarm history	2A40h
	Current alarm	2A41h
	Parameter error number	2A44h
	Parameter error list	2A45h
Monitor Objects	Cumulative feedback pulses	2B01h
	Servo motor speed	2B02h
	Droop pulses	2B03h
	Cumulative command pulses	2B04h
	Command pulse frequency	2B05h
	Regenerative load ratio	2B08h
	Effective load ratio	2B09h
	Peak load ratio	2B0Ah
	Instantaneous torque	2B0Bh
	Within one-revolution position	2B0Ch
	ABS counter	2B0Dh
	Load to motor inertia ratio	2B0Eh
	Bus voltage	2B0Fh
	Load-side cumulative feedback pulses	2B10h
	Load-side droop pulses	2B11h
	Load-side encoder information 1 Z-phase counter	2B12h
	Load-side encoder information 2	2B13h
	Temperature of motor thermistor	2B17h
	Motor-side cumu. feedback pulses (before gear)	2B18h
	Electrical angle	2B19h
Motor-side/load-side position deviation	2B23h	

18. EtherCAT COMMUNICATION

Group	Name	Index	
Monitor Objects	Motor-side/load-side speed deviation	2B24h	
	Internal temperature of encoder	2B25h	
	Settling time	2B26h	
	Oscillation detection frequency	2B27h	
	Number of tough drive operations	2B28h	
	Unit power consumption	2B2Dh	
	Unit total power consumption	2B2Eh	
	Current position	2B2Fh	
	Command position	2B30h	
	Remaining command distance	2B31h	
	Point table No./Program No./Station position No.	2B32h	
	Alarm Monitor 1 Cumulative feedback pulses	2B81h	
	Alarm Monitor 2 Servo motor speed	2B82h	
	Alarm Monitor 3 Droop pulses	2B83h	
	Alarm Monitor 4 Cumulative command pulses	2B84h	
	Alarm Monitor 5 Command pulse frequency	2B85h	
	Alarm Monitor 8 Regenerative load ratio	2B88h	
	Alarm Monitor 9 Effective load ratio	2B89h	
	Alarm Monitor 10 Peak load ratio	2B8Ah	
	Alarm Monitor 11 Instantaneous torque	2B8Bh	
	Alarm Monitor 12 Within one-revolution position	2B8Ch	
	Alarm Monitor 13 ABS counter	2B8Dh	
	Alarm Monitor 14 Load to motor inertia ratio	2B8Eh	
	Alarm Monitor 15 Bus voltage	2B8Fh	
	Alarm Monitor 16 Load-side cumulative feedback pulses	2B90h	
	Alarm Monitor 17 Load-side droop pulses	2B91h	
	Alarm Monitor 18 Load-side encoder information 1 Z-phase counter	2B92h	
	Alarm Monitor 19 Load-side encoder information 2	2B93h	
	Alarm Monitor 23 Temperature of motor thermistor	2B97h	
	Alarm Monitor 24 Motor-side cumu. feedback pulses (before gear)	2B98h	
	Alarm Monitor 25 Electrical angle	2B99h	
	Alarm Monitor 35 Motor-side/load-side position deviation	2BA3h	
	Alarm Monitor 36 Motor-side/load-side speed deviation	2BA4h	
	Alarm Monitor 37 Internal temperature of encoder	2BA5h	
	Alarm Monitor 38 Settling time	2BA6h	
	Alarm Monitor 39 Oscillation detection frequency	2BA7h	
	Alarm Monitor 40 Number of tough drive operations	2BA8h	
	Alarm Monitor 45 Unit power consumption	2BADh	
	Alarm Monitor 46 Unit total power consumption	2BAEh	
	Alarm monitor 47 Current position	2BAFh	
	Alarm monitor 48 Command position	2BB0h	
	Alarm monitor 49 Remaining command distance	2BB1h	
	Alarm monitor 50 Point table No./Program No./Station position No.	2BB2h	
	Manufacturer Specific Control Objects	External Output pin display	2C11h
		Power ON cumulative time	2C18h
		Number of inrush relay on/off times	2C19h
		Machine diagnostic status	2C20h
		Static friction torque at forward rotation	2C21h
		Dynamic friction torque at forward rotation (at rated speed)	2C22h
		Static friction torque at reverse rotation	2C23h
Dynamic friction torque at reverse rotation (at rated speed)		2C24h	

18. EtherCAT COMMUNICATION

Group	Name	Index
Manufacturer Specific Control Objects	Oscillation frequency during motor stop	2C25h
	Vibration level during motor stop	2C26h
	Oscillation frequency during motor operating	2C27h
	Vibration level during motor operating	2C28h
	Control DI 1	2D01h
	Control DI 2	2D02h
	Control DI 3	2D03h
	Status DO 1	2D11h
	Status DO 2	2D12h
	Status DO 3	2D13h
	Status DO 5	2D15h
	Velocity limit value	2D20h
	Watch dog counter DL	2D23h
	Watch dog counter UL	2D24h
	Motor rated speed	2D28h
	Manufacturer Device Name 2	2D30h
	Manufacturer Hardware Version 2	2D31h
	Manufacturer Software Version 2	2D32h
	Serial Number 2	2D33h
	User parameter configuration	2D34h
	Encoder status	2D35h
	Scale cycle counter	2D36h
	Scale ABS counter	2D37h
	Scale measurement encoder resolution	2D38h
	Scale measurement encoder reception status	2D3Ch
	One-touch tuning mode	2D50h
	One-touch tuning status	2D51h
	One-touch tuning Stop	2D52h
	One-touch tuning Clear	2D53h
	One-touch tuning Error Code	2D54h
Torque limit value 2	2D6Bh	
PDS Control Objects	Error code	603Fh
	Controlword	6040h
	Statusword	6041h
	Quick stop option code	605Ah
	Halt option code	605Dh
	Modes of operation	6060h
	Modes of operation display	6061h
	Supported drive modes	6502h
Position Control Function Objects	Position actual internal value	6063h
	Position actual value	6064h
	Following error window	6065h
	Following error time out	6066h
	Position window	6067h
	Position window time	6068h
	Positioning option code	60F2h
	Following error actual value	60F4h
	Control effort	60FAh
Profile Velocity Mode Objects	Velocity demand value	606Bh
	Velocity actual value	606Ch
	Velocity window	606Dh
	Velocity window time	606Eh
	Velocity threshold	606Fh
	Velocity threshold time	6070h
	Target velocity	60FFh

18. EtherCAT COMMUNICATION

Group	Name	Index
Profile Torque Mode Objects	Target torque	6071h
	Max torque	6072h
	Torque demand value	6074h
	Torque actual value	6077h
	Torque slope	6087h
	Torque profile type	6088h
	Positive torque limit value	60E0h
	Negative torque limit value	60E1h
Profile Position Mode Objects	Target position	607Ah
	Position range limit	607Bh
	Software position limit	607Dh
	Max profile velocity	607Fh
	Max motor speed	6080h
	Profile velocity	6081h
	Profile acceleration	6083h
	Profile deceleration	6084h
	Quick stop deceleration	6085h
	Motion profile type	6086h
Homing Mode Objects	Home offset	607Ch
	Homing method	6098h
	Homing speeds	6099h
	Homing acceleration	609Ah
	Supported homing method	60E3h
Factor Group Objects	Polarity	607Eh
	Position encoder resolution	608Fh
	Gear ratio	6091h
	Feed constant	6092h
	SI unit position	60A8h
	SI unit velocity	60A9h
Touch Probe Function Objects	Touch probe function	60B8h
	Touch probe status	60B9h
	Touch probe pos1 pos value	60BAh
	Touch probe pos1 neg value	60BBh
	Touch probe pos2 pos value	60BCh
	Touch probe pos2 neg value	60BDh
Optional application FE Objects	Digital inputs	60FDh
	Digital outputs	60FEh
Point table mode objects	Target point table	2D60h
	Point demand value	2D68h
	Point actual value	2D69h
	Point table _ _ _	2801h to 28FFh
	Point table error	2A43h
	M code actual value	2D6Ah
Cyclic synchronous position mode Objects	Torque offset	60B2h

18. EtherCAT COMMUNICATION

18.7.3 Object dictionary

This section describes the details of the object dictionary for each group.

The following is shown in the "Access" column.

"ro": Only reading is available.

"rw": Reading and writing are available.

"Impossible": The data is not saved to the EEPROM. The value of the data written from the upper side returns to the value of "Default" when the power is shut off.

"Possible": The data can be saved to the EEPROM with Store Parameters (1010h). The data is saved in the parameter corresponding to the object. For the corresponding parameters, refer to "Parameter".

18.7.3.1 General Objects

(1) Device Type (1000h)

Index	Sub	Name		Data Type	Access	PDO Mapping
1000h	0	Device Type		UNSIGNED32	ro	Impossible

Index	Sub	Default	Range	Units	EEP-ROM	Parameter
1000h	0	00020192h	00020192h to 00020192h		Impossible	

The value "00020192h", which indicates a servo drive defined with the CiA 402 profile, is returned.

(2) Error Register (1001h)

Index	Sub	Name		Data Type	Access	PDO Mapping
1001h	0	Error Register		UNSIGNED8	ro	Impossible

Index	Sub	Default	Range	Units	EEP-ROM	Parameter
1001h	0		00h to 01h		Impossible	

The error occurrence is returned.

bit	Description
0	Turns on when an alarm has occurred.
1	Unused
2	Unused
3	Unused
4	Unused
5	Unused
6	Unused
7	Unused

18. EtherCAT COMMUNICATION

(3) Pre-defined error field (1003h)

Index	Sub	Name	Data Type	Access	PDO Mapping
1003h	0	Pre-defined error field	UNSIGNED8	rw	Impossible
	1	Standard error field 1	UNSIGNED32	ro	
	2	Standard error field 2			
	3	Standard error field 3			
	4	Standard error field 4			
	5	Standard error field 5			

Index	Sub	Default	Range	Units	EEP-ROM	Parameter
1003h	0	0	00h to 05h		Impossible	
	1		00000000h or 0000FFFFh			
	2					
	3					
	4					
	5					

The error history that occurred after the power-on is returned. Up to five errors can be stored. Standard error field 1 is the latest error, and Standard error field 5 is the oldest error. This object differs in description depending on the driver software version. The following table shows the details.

Error number	Description
0000FFXXh	Manufacturer specific error If an alarm has occurred, a value that the corresponding alarm No. is added to bit 0 to bit 7 is returned. For example, when [AL 20.1] has occurred, "0000FF20h" is returned.

(4) Manufacturer Device Name (1008h)

Index	Sub	Name	Data Type	Access	PDO Mapping
1008h	0	Manufacturer Device Name	VISIBLE STRING	ro	Impossible

Index	Sub	Default	Range	Units	EEP-ROM	Parameter
1008h	0				Impossible	

This object differs in description depending on the driver software version. The following table shows the details.

Description
The model name of the driver "MR-J4-TM" is returned. To read a detailed model name with the rated output and power supply, such as "MR-J4-10TM1", use Manufacturer Device Name 2 (2D30h).

18. EtherCAT COMMUNICATION

(5) Manufacturer Hardware Version (1009h)

Index	Sub	Name	Data Type	Access	PDO Mapping
1009h	0	Manufacturer Hardware Version	VISIBLE STRING	ro	Impossible

Index	Sub	Default	Range	Units	EEP-ROM	Parameter
1009h	0				Impossible	

The hardware version of the EtherCAT network card is returned. Refer to Manufacturer Hardware Version 2 (2D31h) for the hardware version of the driver.

(6) Manufacturer Software Version (100Ah)

Index	Sub	Name	Data Type	Access	PDO Mapping
100Ah	0	Manufacturer Software Version	VISIBLE STRING	ro	Impossible

Index	Sub	Default	Range	Units	EEP-ROM	Parameter
100Ah	0				Impossible	

The software version of the EtherCAT network card is returned. Refer to Manufacturer Software Version 2 (2D32h) for the software version of the driver.

18. EtherCAT COMMUNICATION

(7) Store parameters (1010h)

Index	Sub	Name	Data Type	Access	PDO Mapping
1010h	0	Store parameters	UNSIGNED8	ro	Impossible
	1	Save all parameters	UNSIGNED32	rw	
	2 (Not supported) (Note)	Save communication parameters			
	3 (Not supported) (Note)	Save application parameters			

Index	Sub	Default	Range	Units	EEP-ROM	Parameter
1010h	0	3	03h	/	Impossible	/
	1	00000001h	Refer to the following table.			
	2 (Not supported) (Note)					
	3 (Not supported) (Note)					

Note. This is not supported by the driver.

Writing "65766173h" (= reverse order of ASCII code of "save") to the corresponding sub object saves an object value in EEPROM. The relationship between Sub Index and the saved object is shown below.

Sub	Saved object
1	All objects

Whether saving a parameter has been completed can be checked by reading this object. The read values are as follows.

bit	Description
0	0: The parameter cannot be saved with the command. (A parameter is being saved.) 1: The parameter can be saved with the command. (No parameter is being saved.)
1	0: The parameter is not automatically saved.
2 to 31	Unused

18. EtherCAT COMMUNICATION

(8) Restore default parameters (1011h)

Index	Sub	Name	Data Type	Access	PDO Mapping
1011h	0	Restore default parameters	UNSIGNED8	ro	Impossible
	1	Restore all default parameters	UNSIGNED32	rw	

Index	Sub	Default	Range	Units	EEP-ROM	Parameter
1011h	0	1	01h		Impossible	
	1	00000001h	Refer to the text.			

The following set values of the driver can be rewritten with the factory setting. When "64616F6Ch" (= reverse order of ASCII code of "load") is written to Restore all default parameters (1011h: 01h) and the power is cycled, the value is initialized. The home position is erased after the power is cycled. Perform home position return again.

- Basic setting parameters ([Pr. PA_ _])
- Gain/filter setting parameters ([Pr. PB_ _])
- Extension setting parameters ([Pr. PC_ _]) (except [Pr. PC11] and [Pr. PC12])
- I/O setting parameters ([Pr. PD_ _])
- Extension setting 2 parameters ([Pr. PE_ _])
- Extension setting 3 parameters ([Pr. PF_ _])
- Linear servo motor/DD motor setting parameters ([Pr. PL_ _])
- Positioning control parameters ([Pr. PT_ _])
- Network setting parameters ([Pr. PN_ _])
- Point table

(9) Identity Object (1018h)

Index	Sub	Name	Data Type	Access	PDO Mapping
1018h	0	Identity Object	UNSIGNED8	ro	Impossible
	1	Vendor ID	UNSIGNED32		
	2	Product Code			
	3	Revision Number			
	4	Serial Number			

Index	Sub	Default	Range	Units	EEP-ROM	Parameter
1018h	0	4	04h		Impossible	
	1	00000A1Eh	00000A1Eh			
	2	00000201h	00000201h			
	3		00000000h to FFFFFFFFh			
	4					

The following values are returned for each Sub Index.

Sub Index	Description
1	Vendor ID of the _ driver
2	Model code of the _ driver
3	Revision number of the _ driver
4	Serial number of the EtherCAT Network card Refer to Serial Number 2 (2D33h) for the serial number of the _ driver.

18. EtherCAT COMMUNICATION

(10) Error Settings (10F1h)

Index	Sub	Name	Data Type	Access	PDO Mapping
10F1h	0	Error Settings	UNSIGNED8	ro	Impossible
	1	Reserved	UNSIGNED32	rw	
	2	Sync Error Counter Limit			

Index	Sub	Default	Range	Units	EEP-ROM	Parameter
10F1h	0		02h		Impossible	
	1		00000000h			
	2		00000000h to 00007FFFh	Refer to the text.	Possible	PN02

Set a threshold at which [AL. 86.1] is detected. When data reception missing occurs, error counter will be incremented by 3 and alarm will be detected when the value of Sync Error Counter Limit (10F1h: 2) is exceeded. Set Sync Error Counter Limit (10F1h: 2) with parameters or objects.

(a) Setting with parameters

[Pr. PN06]	[Pr. PN02]	Sync Error Counter Limit (Index: 10F1h: 2)
Automatic setting (0 _ _ _)	0	The threshold at which [AL. 86.1] is detected is automatically set at 7 ms.
	Other than 0 (Note 3)	The threshold at which [AL. 86.1] is detected is automatically set at ([Pr. PN 02] / 96) ms.
Manual setting (1 _ _ _)	0 (Note 2)	Disabled (0). The detection of [AL. 86.1] is not performed.
	Other than 0 (Note 3)	The value of [Pr. PN02] is set. [AL. 86.1] is detected by (([Pr. PN02] / 3) x communication cycle) ms.

2. If the setting value is set to "0", the servo motor cannot be stopped when a communication error occurs.
3. If the setting value is increased, it takes longer for the servo motor to stop at the occurrence of a communication error. Be careful when changing the setting value as it may cause a collision.

(b) Setting with objects

[Pr. PN06]	Sync Error Counter Limit (Index: 10F1h: 2)	
	Setting value	Description
Automatic setting (0 _ _ _)		In drivers writing any value causes SDO Abort code (06090030h Value range of parameter exceeded). In drivers , writing any value causes SDO Abort code (08000021h Data cannot be transferred or stored to the application because of local control).
Manual setting (1 _ _ _)	0 (Note 2)	The detection of [AL. 86.1] is not performed. When (10F1h: 2) is updated, the value of (10F1h: 2) is set in [Pr. PN02].
	Other than 0 (Note 3)	[AL. 86.1] is detected by (((10F1h: 2) / 3) x communication cycle) ms. When (10F1h: 2) is updated, the value of (10F1h: 2) is set in [Pr. PN02].

2. If the setting value is set to "0", the servo motor cannot be stopped when a communication error occurs.
3. If the setting value is increased, it takes longer for the servo motor to stop at the occurrence of a communication error. Be careful when changing the setting value as it may cause a collision.

18. EtherCAT COMMUNICATION

18.7.3.2 PDO Mapping Objects

(1) Receive PDO Mapping (1600h)

Index	Sub	Name	Data Type	Access	PDO Mapping
1600h	0	Receive PDO Mapping	UNSIGNED8	rw	Impossible
	1	Mapped Object 001	UNSIGNED32		
	.	.			
	.	.			
	32	Mapped Object 032			

Index	Sub	Default	Range	Units	EEP-ROM	Parameter
1600h	0	8	00h to 20h (32)	/	Impossible	/
	1	60600008h	00000000h to FFFFFFFFh			
	.	.				
	.	.				
	32	00000000h				

The object to be mapped for RxPDO can be set. Set the number of objects to be mapped for Receive PDO Mapping (1600h: 0). Set the objects to be mapped for Mapped Object 001 (1600h: 1) to Mapped Object 032 (1600h: 32). The following shows the description of Mapped Object 001 (1600h: 1) to Mapped Object 032 (1600h: 32).

Bit	Description
0 to 7	Length of the object to be mapped (Bit unit) (For the gap in PDO, the bit length of the gap)
8 to 15	Sub Index of the object to be mapped (For the gap in PDO, 0)
16 to 31	The index of the object to be mapped (For the gap in PDO, 0)

(2) Receive PDO Mapping (1601h)

Index	Sub	Name	Data Type	Access	PDO Mapping
1601h	0	Receive PDO Mapping	UNSIGNED8	rw	Impossible
	1	Mapped Object 001	UNSIGNED32		
	.	.			
	.	.			
	32	Mapped Object 032			

Index	Sub	Default	Range	Units	EEP-ROM	Parameter
1601h	0	0	00h to 20h (32)	/	Impossible	/
	1	00000000h	00000000h to FFFFFFFFh			
	.	.				
	.	.				
	32	00000000h				

The details are the same as those of (1) in this section. Refer to (1) in this section.

18. EtherCAT COMMUNICATION

(3) Receive PDO Mapping (1602h)

Index	Sub	Name	Data Type	Access	PDO Mapping
1602h	0	Receive PDO Mapping	UNSIGNED8	rw	Impossible
	1	Mapped Object 001	UNSIGNED32		
	·	·			
	·	·			
32	Mapped Object 032				

Index	Sub	Default	Range	Units	EEP-ROM	Parameter
1602h	0	0	00h to 20h (32)	/	Impossible	/
	1	00000000h	00000000h to FFFFFFFFh			
	·	·				
	·	·				
32	00000000h					

The details are the same as those of (1) in this section. Refer to (1) in this section.

(4) Receive PDO Mapping (1603h)

Index	Sub	Name	Data Type	Access	PDO Mapping
1603h	0	Receive PDO Mapping	UNSIGNED8	rw	Impossible
	1	Mapped Object 001	UNSIGNED32		
	·	·			
	·	·			
32	Mapped Object 032				

Index	Sub	Default	Range	Units	EEP-ROM	Parameter
1603h	0	0	00h to 20h (32)	/	Impossible	/
	1	00000000h	00000000h to FFFFFFFFh			
	·	·				
	·	·				
32	00000000h					

The details are the same as those of (1) in this section. Refer to (1) in this section.

18. EtherCAT COMMUNICATION

(5) Transmit PDO Mapping (1A00h)

Index	Sub	Name	Data Type	Access	PDO Mapping
1A00h	0	Transmit PDO Mapping	UNSIGNED8	rw	Impossible
	1	Mapped Object 001	UNSIGNED32		
	⋮	⋮			
	32	Mapped Object 032			

Index	Sub	Default	Range	Units	EEP-ROM	Parameter
1A00h	0	9	00h to 20h (32)	/	Impossible	/
	1	60610008h	00000000h to FFFFFFFFh			
	⋮	⋮				
	32	00000000h				

The object to be mapped for TxPDO can be set. Set the number of objects to be mapped for Transmit PDO Mapping (1A00h: 0). Set the objects to be mapped for Mapped Object 001 (1A00h: 1) to Mapped Object 032 (1A00h: 32). The following shows the description of Mapped Object 001 (1A00h: 1) to Mapped Object 032 (1A00h: 32).

Bit	Description
0 to 7	Length of the object to be mapped (Bit unit) (For the gap in PDO, the bit length of the gap)
8 to 15	Sub Index of the object to be mapped (For the gap in PDO, 0)
16 to 31	The index of the object to be mapped (For the gap in PDO, 0)

(6) Transmit PDO Mapping (1A01h)

Index	Sub	Name	Data Type	Access	PDO Mapping
1A01h	0	Transmit PDO Mapping	UNSIGNED8	rw	Impossible
	1	Mapped Object 001	UNSIGNED32		
	⋮	⋮			
	32	Mapped Object 032			

Index	Sub	Default	Range	Units	EEP-ROM	Parameter
1A01h	0	0	00h to 20h (32)	/	Impossible	/
	1	00000000h	00000000h to FFFFFFFFh			
	⋮	⋮				
	32	00000000h				

The details are the same as those of (5) in this section. Refer to (5) in this section.

18. EtherCAT COMMUNICATION

(7) Transmit PDO Mapping (1A02h)

Index	Sub	Name	Data Type	Access	PDO Mapping
1A02h	0	Transmit PDO Mapping	UNSIGNED8	rw	Impossible
	1	Mapped Object 001	UNSIGNED32		
	·	·			
	·	·			
32	Mapped Object 032				

Index	Sub	Default	Range	Units	EEP-ROM	Parameter
1A02h	0	0	00h to 20h (32)	/	Impossible	/
	1	00000000h	00000000h to FFFFFFFFh			
	·	·				
	·	·				
32	00000000h					

The details are the same as those of (5) in this section. Refer to (5) in this section.

(8) Transmit PDO Mapping (1A03h)

Index	Sub	Name	Data Type	Access	PDO Mapping
1A03h	0	Transmit PDO Mapping	UNSIGNED8	rw	Impossible
	1	Mapped Object 001	UNSIGNED32		
	·	·			
	·	·			
32	Mapped Object 032				

Index	Sub	Default	Range	Units	EEP-ROM	Parameter
1A03h	0	0	00h to 20h (32)	/	Impossible	/
	1	00000000h	00000000h to FFFFFFFFh			
	·	·				
	·	·				
32	00000000h					

The details are the same as those of (5) in this section. Refer to (5) in this section.

18. EtherCAT COMMUNICATION

18.7.3.3 Sync Manager Communication Objects

(1) Sync Manager Communication Type (1C00h)

Index	Sub	Name	Data Type	Access	PDO Mapping
1C00h	0	Sync Manager Communication Type	UNSIGNED8	ro	Impossible
	1	Sync Manager 0			
	2	Sync Manager 1			
	3	Sync Manager 2			
	4	Sync Manager 3			

Index	Sub	Default	Range	Units	EEP-ROM	Parameter
1C00h	0	4	04h	/	Impossible	/
	1	1	01h			
	2	2	02h			
	3	3	03h			
	4	4	04h			

The information of each Sync Manager is returned. The following shows the description of Sync Manager 0 (1C00h: 1) to Sync Manager 3 (1C00h: 4).

Value	Description
00h	Unused
01h	Received in the mail box (master → slave)
02h	Received in the mail box (slave → master)
03h	Process data output (master → slave)
04h	Process data input (slave → master)

(2) Sync Manager RxPDO assign (1C12h)

Index	Sub	Name	Data Type	Access	PDO Mapping
1C12h	0	Sync Manager RxPDO assign	UNSIGNED8	rw	Impossible
	1	Assigned PDO 001	UNSIGNED16		
	2	Assigned PDO 002			
	3	Assigned PDO 003			
	4	Assigned PDO 004			

Index	Sub	Default	Range	Units	EEP-ROM	Parameter
1C12h	0	1	00h to 04h	/	Impossible	/
	1	1600h	1600h to 1603h			
	2	/				
	3	/				
	4	/				

Set the mapping table to be assigned to Sync Manager 2 (RxPDO). Select an object from Receive PDO Mapping (1600h) to Receive PDO Mapping (1603h).

18. EtherCAT COMMUNICATION

(3) Sync Manager TxPDO assign (1C13h)

Index	Sub	Name	Data Type	Access	PDO Mapping
1C13h	0	Sync Manager TxPDO assign	UNSIGNED8	rw	Impossible
	1	Assigned PDO 001	UNSIGNED16		
	2	Assigned PDO 002			
	3	Assigned PDO 003			
	4	Assigned PDO 004			

Index	Sub	Default	Range	Units	EEP-ROM	Parameter
1C13h	0	1	00h to 04h	/	Impossible	/
	1	1A00h	1A00h to 1A03h			
	2	/				
	3	/				
	4	/				

Set the mapping table to be assigned to Sync Manager 3 (TxPDO). Select an object from Transmit PDO Mapping (1A00h) to Transmit PDO Mapping (1A03h).

(4) SM output parameter (1C32h)

Index	Sub	Name	Data Type	Access	PDO Mapping
1C32h	0	SM output parameter	UNSIGNED8	ro	Impossible
	1	Synchronization Type	UNSIGNED16	rw	
	2	Cycle Time	UNSIGNED32		
	3	Shift Time		rw (Note)	
	4	Synchronization Types supported	UNSIGNED16	ro	
	5	Minimum Cycle Time	UNSIGNED32		
	6	Calc and Copy Time			
	9	Delay Time			
	12	Cycle Time Too Small			

Index	Sub	Default	Range	Units	EEP-ROM	Parameter		
1C32h	0	12	0Ch (12)	/	Impossible	/		
	1	0	0000h or 0002h					
	2	250000	0003D090h (250000) 0007A120h (500000) 000F4240h (1000000) 001E8480h (2000000)				ns	
	3	222222	222222				/	
	4	0025h	0025h (35)					
	5	250000	0003D090h (250000)					ns
	6	222722	00000000h to FFFFFFFFh					
	9	0	00000000h					
	12	0	0000h					

Note. No value can be written because Shift time (1C32: 3) is set automatically. Writing any value causes SDO Abort Code (0609 0030h Value range of parameter exceeded).

Set Sync Manager 2 (RxPDO). The description of each Sub Index is as follows.

Sub	Name	Description
0	SM output parameter	The number of entries is returned.
1	Synchronization Type	Set the synchronous mode. 0000h: Free Run 0001h: Synchronous (Not supported) (Note 2) 0002h: DC Sync0 0003h: DC Sync1 (Not supported) (Note 2) The value can be changed in the Pre Operational state. If the value of 1C33h: 1 is changed, the same value as that of 1C33h: 1 is automatically set to this sub index.
2	Cycle Time	Set the RxPDO communication cycle. 250000: 0.25 ms 500000: 0.5 ms 1000000: 1 ms 2000000: 2 ms The PDO communication cycle can be changed by changing the value in the Pre Operational state. Communication cycles other than the above cannot be set. If the value of 1C33h: 2 is changed, the same value as that of 1C33h: 2 is automatically set to this sub index.
3	Shift Time	The delay time from SYNC0 to output is returned. Unit: [ns]
4	Synchronization Types supported	The supported synchronous type is returned. Bit 0: Free Run supported Bit 1: Synchronous supported (Not supported) (Note 2) Bit 4 to Bit 2: DC Type supported 000 = No DC (Not supported) (Note 2) 001 = DC Sync0 010 = DC Sync1 (Not supported) (Note 2) 100 = Subordinated Application with fixed Sync0 (Not supported) (Note 2) Bit 6 to Bit 5: Shift settings 00 = No Output Shift supported (Not supported) (Note 2) 01 = Output Shift with local time 10 = Output Shift with Sync1 (Not supported) (Note 2) Bit 9 to Bit 7: Reserved Bit 10: Delay Time should be measured (Not supported) (Note 2) Bit 11: Delay Time is fix. (Not supported) (Note 2) Bit 13 to Bit 11: Reserved Bit 14: Dynamic Cycle Times (Not supported) (Note 2) Bit 15: Reserved
5	Minimum Cycle Time	The minimum communication cycle is returned. Unit: [ns]
6	Calc and Copy Time	The minimum value of the delay time from data reception to output is returned. The value varies according to the communication cycle setting. Unit: [ns]
9	Delay Time	Not supported (Note 2)
12	Cycle Time Too Small	Not supported (Note 2)

2. This is not supported by the driver.

18. EtherCAT COMMUNICATION

(5) SM input parameter (1C33h)

Index	Sub	Name	Data Type	Access	PDO Mapping
1C33h	0	SM input parameter	UNSIGNED8	ro	Impossible
	1	Synchronization Type	UNSIGNED16	rw	
	2	Cycle Time	UNSIGNED32		
	3	Shift Time		rw (Note)	
	4	Synchronization Types supported	UNSIGNED16	ro	
	5	Minimum Cycle Time	UNSIGNED32		
	6	Calc and Copy Time			
	9	Delay Time			
12	Cycle Time Too Small	UNSIGNED16			

Index	Sub	Default	Range	Units	EEP-ROM	Parameter
1C33h	0	12	0Ch (12)		Impossible	
	1	0	0000h or 0002h			
	2	250000	0003D090h (250000) 0007A120h (500000) 000F4240h (1000000) 001E8480h (2000000)	ns		
	3	27778	00000000h to FFFFFFFFh			
	4	0025h	0025h (35)			
	5	250000	0003D090h (250000)	ns		
	6	306055	00000000h to FFFFFFFFh			
	9	0	00000000h			
12	0	0000h				

Note. No value can be written because Shift time (1C33: 3) is set automatically. Writing any value causes SDO Abort Code (0609 0030h Value range of parameter exceeded).

Set Sync Manager 3 (TxPDO). The description of each Sub Index is as follows.

Sub	Name	Description
0	SM output parameter	The number of entries is returned.
1	Synchronization Type	Set the synchronous mode. 0000h: Free Run 0001h: Synchronous (Not supported) (Note 2) 0002h: DC Sync0 0003h: DC Sync1 (Not supported) (Note 2) The value can be changed in the Pre Operational state. If the value of 1C32h: 1 is changed, the same value as that of 1C32h: 1 is automatically set to this sub index.
2	Cycle Time	Set the TxPDO communication cycle. 250000: 0.25 ms 500000: 0.5 ms 1000000: 1 ms 2000000: 2 ms The PDO communication cycle can be changed by changing the value in the Pre Operational state. Communication cycles other than the above cannot be set. If the value of 1C32h: 2 is changed, the same value as that of 1C32h: 2 is automatically set to this sub index.
3	Shift Time	The delay time from SYNC0 to input is returned. Unit: [ns]
4	Synchronization Types supported	The supported synchronous type is returned. Bit 0: Free Run supported Bit 1: Synchronous supported (Not supported) (Note 2) Bit 4 to Bit 2: DC Type supported 000 = No DC (Not supported) (Note 2) 001 = DC Sync0 010 = DC Sync1 (Not supported) (Note 2) 100 = Subordinated Application with fixed Sync0 (Not supported) (Note 2) Bit 6 to Bit 5: Shift settings 00 = No Output Shift supported (Not supported) (Note 2) 01 = Output Shift with local time 10 = Output Shift with Sync1 (Not supported) (Note 2) Bit 9 to Bit 7: Reserved Bit 10: Delay Time should be measured (Not supported) (Note 2) Bit 11: Delay Time is fix. (Not supported) (Note 2) Bit 13 to Bit 11: Reserved Bit 14: Dynamic Cycle Times (Not supported) (Note 2) Bit 15: Reserved
5	Minimum Cycle Time	The minimum communication cycle is returned. Unit: [ns]
6	Calc and Copy Time	The minimum value of the delay time from input to sending is returned. The value varies according to the communication cycle setting. Unit: [ns]
9	Delay Time	Not supported (Note 2)
12	Cycle Time Too Small	Not supported (Note 2)

2. This is not supported by the driver.

18. EtherCAT COMMUNICATION

18.7.3.4 Parameter Objects

(1) Parameter Objects PA (2001h to 2020h)

Index	Sub	Name	Data Type	Access	PDO Mapping
2001h	0	PA01	INTEGER32	rw	Impossible
·		·			
·		·			
2020h		PA32			

Index	Sub	Default	Range	Units	EEP-ROM	Parameter
2001h	0		Refer to "_ Driver Instruction Manual".		Possible	PA01
·		·				·
·		·				·
2020h						PA32

The value of the basic setting parameters ([Pr. PA_ _]) can be obtained and set.

(2) Parameter Objects PB (2081h to 20C0h)

Index	Sub	Name	Data Type	Access	PDO Mapping
2081h	0	PB01	INTEGER32	rw	Impossible
·		·			
·		·			
20C0h		PB64			

Index	Sub	Default	Range	Units	EEP-ROM	Parameter
2081h	0		Refer to "_ Driver Instruction Manual".		Possible	PB01
·		·				·
·		·				·
20C0h						PB64

The value of the gain/filter setting parameters ([Pr. PB_ _]) can be obtained and set.

(3) Parameter Objects PC (2101h to 2150h)

Index	Sub	Name	Data Type	Access	PDO Mapping
2101h	0	PC01	INTEGER32	rw	Impossible
·		·			
·		·			
2150h		PC80			

Index	Sub	Default	Range	Units	EEP-ROM	Parameter
2101h	0		Refer to "_ Driver Instruction Manual".		Possible	PC01
·		·				·
·		·				·
2150h						PC80

The value of the extension setting parameters ([Pr. PC_ _]) can be obtained and set.

18. EtherCAT COMMUNICATION

(4) Parameter Objects PD (2181h to 21B0h)

Index	Sub	Name	Data Type	Access	PDO Mapping
2181h	0	PD01	INTEGER32	rw	Impossible
·		·			
·		·			
21B0h		PD48			

Index	Sub	Default	Range	Units	EEP-ROM	Parameter
2181h	0		Refer to "_ Driver Instruction Manual".		Possible	PD01
·		·				·
·		·				·
21B0h						PD48

The value of the I/O setting parameters ([Pr. PD_ _]) can be obtained and set.

(5) Parameter Objects PE (2201h to 2240h)

Index	Sub	Name	Data Type	Access	PDO Mapping
2201h	0	PE01	INTEGER32	rw	Impossible
·		·			
·		·			
2240h		PE64			

Index	Sub	Default	Range	Units	EEP-ROM	Parameter
2201h	0		Refer to "_ Driver Instruction Manual".		Possible	PE01
·		·				·
·		·				·
2240h						PE64

The value of the extension setting 2 parameters ([Pr. PE_ _]) can be obtained and set.

(6) Parameter Objects PF (2281h to 22C0h)

Index	Sub	Name	Data Type	Access	PDO Mapping
2281h	0	PF01	INTEGER32	rw	Impossible
·		·			
·		·			
22C0h		PF64			

Index	Sub	Default	Range	Units	EEP-ROM	Parameter
2281h	0		Refer to "_ Driver Instruction Manual".		Possible	PF01
·		·				·
·		·				·
22C0h						PF64

The value of the extension setting 3 parameters ([Pr. PF_ _]) can be obtained and set.

18. EtherCAT COMMUNICATION

(7) Parameter Objects PL (2401h to 2430h)

Index	Sub	Name	Data Type	Access	PDO Mapping
2401h	0	PL01	INTEGER32	rw	Impossible
·		·			
·		·			
2430h		PL48			

Index	Sub	Default	Range	Units	EEP-ROM	Parameter
2401h	0		Refer to "_ Driver Instruction Manual".		Possible	PL01
·		·				·
·		·				·
2430h						PL48

The value of the linear servo motor/DD motor setting parameters ([Pr. PL_ _]) can be obtained and set.

(8) Parameter Objects PT (2481h to 24D0h)

Index	Sub	Name	Data Type	Access	PDO Mapping
2481h	0	PT01	INTEGER32	rw	Impossible
·		·			
·		·			
24D0h		PT80			

Index	Sub	Default	Range	Units	EEP-ROM	Parameter
2481h	0		Refer to "_ Driver Instruction Manual".		Possible	PT01
·		·				·
·		·				·
24D0h						PT80

The value of the positioning control parameters ([Pr. PT_ _]) can be obtained and set.

(9) Parameter Objects PN (2581h to 25A0h)

Index	Sub	Name	Data Type	Access	PDO Mapping
2581h	0	PN01	INTEGER32	rw	Impossible
·		·			
·		·			
25A0h		PN32			

Index	Sub	Default	Range	Units	EEP-ROM	Parameter
2581h	0		Refer to "_ Driver Instruction Manual".		Possible	PN01
·		·				·
·		·				·
25A0h						PN32

The value of the network setting parameters ([Pr. PN_ _]) can be obtained and set.

18. EtherCAT COMMUNICATION

18.7.3.5 Alarm Objects

(1) Alarm history newest (2A00h)

Index	Sub	Name	Data Type	Access	PDO Mapping
2A00h	0	Alarm history newest	UNSIGNED8	ro	Impossible
	1	Alarm No.	UNSIGNED32		
	2	Alarm time (Hour)			

Index	Sub	Default	Range	Units	EEP-ROM	Parameter
2A00h	0	2	02h to 02h		Possible	
	1	0	00000000h to FFFFFFFFh			
	2	0	00000000h to FFFFFFFFh	hour		

The latest alarm information of the alarm history is returned. The description of each Sub Index is as follows.

Sub	Name	Description
0	Alarm history newest	The number of entries is returned.
1	Alarm No.	The number of the alarm that has occurred is returned. The description is as follows. When no history exists, 0 is returned. Bit 0 to Bit 15: Alarm detail No. Bit 16 to Bit 31: Alarm No. If [AL. 16.3] occurs, 00160003h is returned.
2	Alarm time (Hour)	Alarm occurrence time is returned. When no history exists, 0 is returned. Unit: [hour]

(2) Alarm history 1 (2A01h) to Alarm history 15 (2A0Fh)

Index	Sub	Name	Data Type	Access	PDO Mapping
2A01h to 2A0Fh	0	Alarm history 1 to Alarm history 15	UNSIGNED8	ro	Impossible
	1	Alarm No.	UNSIGNED32		
	2	Alarm time (Hour)			

Index	Sub	Default	Range	Units	EEP-ROM	Parameter
2A01h to 2A0Fh	0	2	02h to 02h		Possible	
	1	0	00000000h to FFFFFFFFh			
	2	0	00000000h to FFFFFFFFh	hour		

The second (2A01h) to 16th (2A0Fh) latest alarm information of the alarm history is returned. The description of each Sub Index is the same as that of (1) in this section.

(3) Clear alarm history (2A40h)

Index	Sub	Name	Data Type	Access	PDO Mapping
2A40h	0	Clear alarm history	UNSIGNED16	wo	Impossible

Index	Sub	Default	Range	Units	EEP-ROM	Parameter
2A40h	0		Refer to the text.		Impossible	

Writing "1EA5h" clears the alarm history.

18. EtherCAT COMMUNICATION

(4) Current alarm (2A41h)

Index	Sub	Name	Data Type	Access	PDO Mapping
2A41h	0	Current alarm	UNSIGNED32	ro	Possible

Index	Sub	Default	Range	Units	EEP-ROM	Parameter
2A41h	0		00000000h to FFFFFFFFh		Impossible	

The number of the current alarm is returned. When no alarm has occurred, "00000000h" is returned. The description of the values is as follows. If [AL. 16.3] occurs, "00160003h" is returned.

Bit	Description
0 to 15	Alarm detail No.
16 to 31	Alarm No.

(5) Parameter error number (2A44h)

Index	Sub	Name	Data Type	Access	PDO Mapping
2A44h	0	Parameter error number	UNSIGNED16	ro	Impossible

Index	Sub	Default	Range	Units	EEP-ROM	Parameter
2A44h	0		0000h to 01F4h (500)		Impossible	

When [AL. 37 Parameter error] has occurred, the number of the parameters which cause the error is returned. Refer to Parameter error list (2A45h) for the number of each parameter which causes the error.

(6) Parameter error list (2A45h)

Index	Sub	Name	Data Type	Access	PDO Mapping
2A45h	0	Parameter error list	UNSIGNED8	ro	Impossible
	1	No. 1	UNSIGNED16		
	·	·			
	·	·			
	·	·			
16	No. 16				

Index	Sub	Default	Range	Units	EEP-ROM	Parameter
2A45h	0		10h to 10h (16)		Impossible	
	1		0000h to FFFFh			
	·	·				
	·	·				
	·	·				
16						

A list of parameter No. in which [AL. 37 Parameter error] has occurred is returned. The description of 2A45h: 1 to 2A45h: 16 is as follows. If [Pr. PC01] is an error factor, "0201h" is returned. If more than 17 parameter errors have occurred, the 17th and later parameter errors are returned after the parameters are corrected and the power is cycled.

Bit	Description
0 to 7	Parameter number
8 to 15	Parameter group number
	00: [Pr. PA __]
	01: [Pr. PB __]
	02: [Pr. PC __]
	03: [Pr. PD __]
	04: [Pr. PE __]
	05: [Pr. PF __]
	06: Parameter for manufacturer setting
	07: Parameter for manufacturer setting
	08: Parameter for manufacturer setting
	09: Parameter for manufacturer setting
	0A: Parameter for manufacturer setting
	0B: [Pr. PL __]
	0C: [Pr. PT __]
0E: [Pr. PN __]	

18. EtherCAT COMMUNICATION

18.7.3.6 Monitor Objects

(1) Cumulative feedback pulses (2B01h)

Index	Sub	Name	Data Type	Access	PDO Mapping
2B01h	0	Cumulative feedback pulses	INTEGER32	rw	Possible

Index	Sub	Default	Range	Units	EEP-ROM	Parameter
2B01h	0		80000000h to FFFFFFFFh	pulse	Impossible	

The cumulative feedback pulses are returned. Writing "00001EA5h" clears the cumulative feedback pulses.

(2) Servo motor speed (2B02h)

Index	Sub	Name	Data Type	Access	PDO Mapping
2B02h	0	Servo motor speed	INTEGER32	ro	Possible

Index	Sub	Default	Range	Units	EEP-ROM	Parameter
2B02h	0		80000000h to 7FFFFFFFh	Refer to the text.	Impossible	

The servo motor speed is returned.

Unit: [r/min] ([mm/s] when a linear servo motor is used)

(3) Droop pulses (2B03h)

Index	Sub	Name	Data Type	Access	PDO Mapping
2B03h	0	Droop pulses	INTEGER32	ro	Possible

Index	Sub	Default	Range	Units	EEP-ROM	Parameter
2B03h	0		80000000h to 7FFFFFFFh	pulse	Impossible	

The droop pulses (encoder unit) are returned.

(4) Cumulative command pulses (2B04h)

Index	Sub	Name	Data Type	Access	PDO Mapping
2B04h	0	Cumulative command pulses	INTEGER32	ro	Possible

Index	Sub	Default	Range	Units	EEP-ROM	Parameter
2B04h	0		80000000h to FFFFFFFFh	pulse	Impossible	

The cumulative command pulses are returned.

(5) Command pulse frequency (2B05h)

Index	Sub	Name	Data Type	Access	PDO Mapping
2B05h	0	Command pulse frequency	INTEGER32	ro	Possible

Index	Sub	Default	Range	Units	EEP-ROM	Parameter
2B05h	0		80000000h to FFFFFFFFh	kpulse/s	Impossible	

The command pulse frequency is returned.

18. EtherCAT COMMUNICATION

(6) Regenerative load ratio (2B08h)

Index	Sub	Name	Data Type	Access	PDO Mapping
2B08h	0	Regenerative load ratio	UNSIGNED16	ro	Possible

Index	Sub	Default	Range	Units	EEP-ROM	Parameter
2B08h	0		0000h to FFFFh	%	Impossible	

The regenerative load ratio is returned.

(7) Effective load ratio (2B09h)

Index	Sub	Name	Data Type	Access	PDO Mapping
2B09h	0	Effective load ratio	UNSIGNED16	ro	Possible

Index	Sub	Default	Range	Units	EEP-ROM	Parameter
2B09h	0		0000h to FFFFh	%	Impossible	

The effective load ratio is returned.

(8) Peak load ratio (2B0Ah)

Index	Sub	Name	Data Type	Access	PDO Mapping
2B0Ah	0	Peak load ratio	UNSIGNED16	ro	Possible

Index	Sub	Default	Range	Units	EEP-ROM	Parameter
2B0Ah	0		0000h to FFFFh	%	Impossible	

The peak load ratio is returned.

(9) Instantaneous torque (2B0Bh)

Index	Sub	Name	Data Type	Access	PDO Mapping
2B0Bh	0	Instantaneous torque	INTEGER16	ro	Possible

Index	Sub	Default	Range	Units	EEP-ROM	Parameter
2B0Bh	0		8000h to 7FFFh	%	Impossible	

The instantaneous torque is returned.

(10) Within one-revolution position (2B0Ch)

Index	Sub	Name	Data Type	Access	PDO Mapping
2B0Ch	0	Within one-revolution position	INTEGER32	ro	Possible

Index	Sub	Default	Range	Units	EEP-ROM	Parameter
2B0Ch	0		80000000h to 7FFFFFFFh	pulse	Impossible	

The position within one-revolution is returned.

18. EtherCAT COMMUNICATION

(11) ABS counter (2B0Dh)

Index	Sub	Name		Data Type	Access	PDO Mapping
2B0Dh	0	ABS counter		INTEGER32	ro	Possible
Index	Sub	Default	Range	Units	EEP-ROM	Parameter
2B0Dh	0		80000000h to 7FFFFFFFh	rev	Impossible	

The ABS counter is returned.

(12) Load to motor inertia ratio (2B0Eh)

Index	Sub	Name		Data Type	Access	PDO Mapping
2B0Eh	0	Load to motor inertia ratio		UNSIGNED16	ro	Possible
Index	Sub	Default	Range	Units	EEP-ROM	Parameter
2B0Eh	0		0000h to FFFFh	0.01 times	Impossible	

The load to motor inertia ratio is returned.

(13) Bus voltage (2B0Fh)

Index	Sub	Name		Data Type	Access	PDO Mapping
2B0Fh	0	Bus voltage		UNSIGNED16	ro	Possible
Index	Sub	Default	Range	Units	EEP-ROM	Parameter
2B0Fh	0		0000h to FFFFh	V	Impossible	

The bus voltage is returned.

(14) Load-side cumulative feedback pulses (2B10h)

Index	Sub	Name		Data Type	Access	PDO Mapping
2B10h	0	Load-side cumulative feedback pulses		INTEGER32	ro	Possible
Index	Sub	Default	Range	Units	EEP-ROM	Parameter
2B10h	0		80000000h to 7FFFFFFFh	pulse	Impossible	

The load-side cumulative feedback pulses (load-side encoder unit) are returned.

(15) Load-side droop pulses (2B11h)

Index	Sub	Name		Data Type	Access	PDO Mapping
2B11h	0	Load-side droop pulses		INTEGER32	ro	Possible
Index	Sub	Default	Range	Units	EEP-ROM	Parameter
2B11h	0		80000000h to 7FFFFFFFh	pulse	Impossible	

The load-side droop pulses are returned.

18. EtherCAT COMMUNICATION

(16) Load-side encoder information 1 Z-phase counter (2B12h)

Index	Sub	Name		Data Type	Access	PDO Mapping
2B12h	0	Load-side encoder information 1 Z-phase counter		INTEGER32	ro	Possible
Index	Sub	Default	Range	Units	EEP-ROM	Parameter
2B12h	0		80000000h to 7FFFFFFFh	pulse	Impossible	

The load-side encoder information 1 is returned.

(17) Load-side encoder information 2 (2B13h)

Index	Sub	Name		Data Type	Access	PDO Mapping
2B13h	0	Load-side encoder information 2		INTEGER32	ro	Possible
Index	Sub	Default	Range	Units	EEP-ROM	Parameter
2B13h	0		80000000h to 7FFFFFFFh	rev	Impossible	

The load-side encoder information 2 is returned.

(18) Temperature of motor thermistor (2B17h)

Index	Sub	Name		Data Type	Access	PDO Mapping
2B17h	0	Temperature of motor thermistor		INTEGER16	ro	Possible
Index	Sub	Default	Range	Units	EEP-ROM	Parameter
2B17h	0		8000h to 7FFFh	°C	Impossible	

The temperature of servo motor thermistor is returned.

(19) Motor-side cumu. feedback pulses (before gear) (2B18h)

Index	Sub	Name		Data Type	Access	PDO Mapping
2B18h	0	Motor-side cumu. feedback pulses (before gear)		INTEGER32	ro	Possible
Index	Sub	Default	Range	Units	EEP-ROM	Parameter
2B18h	0		80000000h to 7FFFFFFFh	pulse	Impossible	

The cumulative feedback pulses are returned.

(20) Electrical angle (2B19h)

Index	Sub	Name		Data Type	Access	PDO Mapping
2B19h	0	Electrical angle		INTEGER32	ro	Possible
Index	Sub	Default	Range	Units	EEP-ROM	Parameter
2B19h	0		80000000h to 7FFFFFFFh	pulse	Impossible	

The electrical angle is returned.

18. EtherCAT COMMUNICATION

(21) Motor-side/load-side position deviation (2B23h)

Index	Sub	Name	Data Type	Access	PDO Mapping	
2B23h	0	Motor-side/load-side position deviation	INTEGER32	ro	Possible	
Index	Sub	Default	Range	Units	EEP-ROM	Parameter
2B23h	0		80000000h to 7FFFFFFFh	pulse	Impossible	

The servo motor-side/load-side position deviation is returned.

(22) Motor-side/load-side speed deviation (2B24h)

Index	Sub	Name	Data Type	Access	PDO Mapping	
2B24h	0	Motor-side/load-side speed deviation	INTEGER32	ro	Possible	
Index	Sub	Default	Range	Units	EEP-ROM	Parameter
2B24h	0		80000000h to 7FFFFFFFh	r/min	Impossible	

The servo motor-side/load-side speed deviation is returned.

(23) Internal temperature of encoder (2B25h)

Index	Sub	Name	Data Type	Access	PDO Mapping	
2B25h	0	Internal temperature of encoder	INTEGER16	ro	Possible	
Index	Sub	Default	Range	Units	EEP-ROM	Parameter
2B25h	0		8000h to 7FFFh	°C	Impossible	

The internal temperature of encoder is returned.

(24) Settling time (2B26h)

Index	Sub	Name	Data Type	Access	PDO Mapping	
2B26h	0	Settling time	INTEGER16	ro	Possible	
Index	Sub	Default	Range	Units	EEP-ROM	Parameter
2B26h	0		8000h to 7FFFh	ms	Impossible	

The settling time is returned.

(25) Oscillation detection frequency (2B27h)

Index	Sub	Name	Data Type	Access	PDO Mapping	
2B27h	0	Oscillation detection frequency	INTEGER16	ro	Possible	
Index	Sub	Default	Range	Units	EEP-ROM	Parameter
2B27h	0		8000h to 7FFFh	Hz	Impossible	

The oscillation detection frequency is returned.

18. EtherCAT COMMUNICATION

(26) Number of tough drive operations (2B28h)

Index	Sub	Name		Data Type	Access	PDO Mapping
2B28h	0	Number of tough drive operations		UNSIGNED16	ro	Possible
Index	Sub	Default	Range	Units	EEP-ROM	Parameter
2B28h	0		0000h to FFFFh	number of times	Impossible	

The number of tough drive operations is returned.

(27) Unit power consumption (2B2Dh)

Index	Sub	Name		Data Type	Access	PDO Mapping
2B2Dh	0	Unit power consumption		INTEGER16	ro	Possible
Index	Sub	Default	Range	Units	EEP-ROM	Parameter
2B2Dh	0		8000h to 7FFFh	W	Impossible	

The unit power consumption is returned.

(28) Unit total power consumption (2B2Eh)

Index	Sub	Name		Data Type	Access	PDO Mapping
2B2Eh	0	Unit total power consumption		INTEGER32	ro	Possible
Index	Sub	Default	Range	Units	EEP-ROM	Parameter
2B2Eh	0		80000000h to 7FFFFFFFh	Wh	Impossible	

The unit total power consumption is returned.

(29) Current position (2B2Fh)

Index	Sub	Name		Data Type	Access	PDO Mapping
2B2Fh	0	Current position		INTEGER32	ro	Possible
Index	Sub	Default	Range	Units	EEP-ROM	Parameter
2B2Fh	0		80000000h to 7FFFFFFFh	pos units	Impossible	

The current position is returned. In the indexer method, the value is fixed to 0.
This object is available with drivers

(30) Command position (2B30h)

Index	Sub	Name		Data Type	Access	PDO Mapping
2B30h	0	Command position		INTEGER32	ro	Possible
Index	Sub	Default	Range	Units	EEP-ROM	Parameter
2B30h	0		80000000h to 7FFFFFFFh	pos units	Impossible	

The command position is returned. In the indexer method, the value is fixed to 0.
This object is available with drivers

18. EtherCAT COMMUNICATION

(31) Remaining command distance (2B31h)

Index	Sub	Name		Data Type	Access	PDO Mapping
2B31h	0	Remaining command distance		INTEGER32	ro	Possible
Index	Sub	Default	Range	Units	EEP-ROM	Parameter
2B31h	0		80000000h to 7FFFFFFFh	pos units	Impossible	

The command remaining distance is returned.
This object is available with drivers

(32) Point table No./Program No./Station position No. (2B32h)

Index	Sub	Name		Data Type	Access	PDO Mapping
2B32h	0	Point table No./Program No./Station position No.		INTEGER16	ro	Possible
Index	Sub	Default	Range	Units	EEP-ROM	Parameter
2B32h	0		0000h to 00FFh		Impossible	

Point table No. or station position No. is returned.
This object is available with drivers

(33) Alarm Monitor 1 Cumulative feedback pulses (2B81h)

Index	Sub	Name		Data Type	Access	PDO Mapping
2B81h	0	Alarm Monitor 1 Cumulative feedback pulses		INTEGER32	ro	Possible
Index	Sub	Default	Range	Units	EEP-ROM	Parameter
2B81h	0		80000000h to 7FFFFFFFh	pulse	Impossible	

The cumulative feedback pulses at alarm occurrence are returned.

(34) Alarm Monitor 2 Servo motor speed (2B82h)

Index	Sub	Name		Data Type	Access	PDO Mapping
2B82h	0	Alarm Monitor 2 Servo motor speed		INTEGER32	ro	Possible
Index	Sub	Default	Range	Units	EEP-ROM	Parameter
2B82h	0		80000000h to 7FFFFFFFh	Refer to the text.	Impossible	

The servo motor speed at alarm occurrence is returned.
Unit: [r/min] ([mm/s] when a linear servo motor is used)

(35) Alarm Monitor 3 Droop pulses (2B83h)

Index	Sub	Name		Data Type	Access	PDO Mapping
2B83h	0	Alarm Monitor 3 Droop pulses		INTEGER32	ro	Possible
Index	Sub	Default	Range	Units	EEP-ROM	Parameter
2B83h	0		80000000h to 7FFFFFFFh	pulse	Impossible	

The droop pulses at alarm occurrence are returned.

18. EtherCAT COMMUNICATION

(36) Alarm Monitor 4 Cumulative command pulses (2B84h)

Index	Sub	Name		Data Type	Access	PDO Mapping
2B84h	0	Alarm Monitor 4 Cumulative command pulses		INTEGER32	ro	Possible
Index	Sub	Default	Range	Units	EEP-ROM	Parameter
2B84h	0		80000000h to 7FFFFFFFh	pulse	Impossible	

The cumulative command pulses (encoder unit) at alarm occurrence are returned.

(37) Alarm Monitor 5 Command pulse frequency (2B85h)

Index	Sub	Name		Data Type	Access	PDO Mapping
2B85h	0	Alarm Monitor 5 Command pulse frequency		INTEGER32	ro	Possible
Index	Sub	Default	Range	Units	EEP-ROM	Parameter
2B85h	0		80000000h to 7FFFFFFFh	kpulse/s	Impossible	

The command pulse frequency at alarm occurrence is returned.

(38) Alarm Monitor 8 Regenerative load ratio (2B88h)

Index	Sub	Name		Data Type	Access	PDO Mapping
2B88h	0	Alarm Monitor 8 Regenerative load ratio		UNSIGNED16	ro	Possible
Index	Sub	Default	Range	Units	EEP-ROM	Parameter
2B88h	0		0000h to FFFFh	%	Impossible	

The regenerative load ratio at alarm occurrence is returned.

(39) Alarm Monitor 9 Effective load ratio (2B89h)

Index	Sub	Name		Data Type	Access	PDO Mapping
2B89h	0	Alarm Monitor 9 Effective load ratio		UNSIGNED16	ro	Possible
Index	Sub	Default	Range	Units	EEP-ROM	Parameter
2B89h	0		0000h to FFFFh	%	Impossible	

The effective load ratio at alarm occurrence is returned.

(40) Alarm Monitor 10 Peak load ratio (2B8Ah)

Index	Sub	Name		Data Type	Access	PDO Mapping
2B8Ah	0	Alarm Monitor 10 Peak load ratio		UNSIGNED16	ro	Possible
Index	Sub	Default	Range	Units	EEP-ROM	Parameter
2B8Ah	0		0000h to FFFFh	%	Impossible	

The peak load ratio at alarm occurrence is returned.

18. EtherCAT COMMUNICATION

(41) Alarm Monitor 11 Instantaneous torque (2B8Bh)

Index	Sub	Name		Data Type	Access	PDO Mapping
2B8Bh	0	Alarm Monitor 11 Instantaneous torque		INTEGER16	ro	Possible
Index	Sub	Default	Range	Units	EEP-ROM	Parameter
2B8Bh	0		8000h to 7FFFh	%	Impossible	

The instantaneous torque at alarm occurrence is returned.

(42) Alarm Monitor 12 Within one-revolution position (2B8Ch)

Index	Sub	Name		Data Type	Access	PDO Mapping
2B8Ch	0	Alarm Monitor 12 Within one-revolution position		INTEGER32	ro	Possible
Index	Sub	Default	Range	Units	EEP-ROM	Parameter
2B8Ch	0		80000000h to 7FFFFFFFh	pulse	Impossible	

The position within one-revolution at alarm occurrence is returned.

(43) Alarm Monitor 13 ABS counter (2B8Dh)

Index	Sub	Name		Data Type	Access	PDO Mapping
2B8Dh	0	Alarm Monitor 13 ABS counter		INTEGER32	ro	Possible
Index	Sub	Default	Range	Units	EEP-ROM	Parameter
2B8Dh	0		80000000h to 7FFFFFFFh	rev	Impossible	

The ABS counter at alarm occurrence is returned.

(44) Alarm Monitor 14 Load to motor inertia ratio (2B8Eh)

Index	Sub	Name		Data Type	Access	PDO Mapping
2B8Eh	0	Alarm Monitor 14 Load to motor inertia ratio		UNSIGNED16	ro	Possible
Index	Sub	Default	Range	Units	EEP-ROM	Parameter
2B8Eh	0		0000h to FFFFh	0.1 times	Impossible	

The load to motor inertia ratio at alarm occurrence is returned.

(45) Alarm Monitor 15 Bus voltage (2B8Fh)

Index	Sub	Name		Data Type	Access	PDO Mapping
2B8Fh	0	Alarm Monitor 15 Bus voltage		INTEGER32	ro	Possible
Index	Sub	Default	Range	Units	EEP-ROM	Parameter
2B8Fh	0		80000000h to 7FFFFFFFh	V	Impossible	

The bus voltage at alarm occurrence is returned.

18. EtherCAT COMMUNICATION

(46) Alarm Monitor 16 Load-side cumulative feedback pulses (2B90h)

Index	Sub	Name	Data Type	Access	PDO Mapping	
2B90h	0	Alarm Monitor 16 Load-side cumulative feedback pulses	INTEGER32	ro	Possible	
Index	Sub	Default	Range	Units	EEP-ROM	Parameter
2B90h	0		80000000h to 7FFFFFFFh	pulse	Impossible	

The load-side cumulative feedback pulses at alarm occurrence are returned.

(47) Alarm Monitor 17 Load-side droop pulses (2B91h)

Index	Sub	Name	Data Type	Access	PDO Mapping	
2B91h	0	Alarm Monitor 17 Load-side droop pulses	INTEGER32	ro	Possible	
Index	Sub	Default	Range	Units	EEP-ROM	Parameter
2B91h	0		80000000h to 7FFFFFFFh	pulse	Impossible	

The load-side droop pulses (load-side encoder unit) at alarm occurrence are returned.

(48) Alarm Monitor 18 Load-side encoder information 1 Z-phase counter (2B92h)

Index	Sub	Name	Data Type	Access	PDO Mapping	
2B92h	0	Alarm Monitor 18 Load-side encoder information 1 Z-phase counter	INTEGER32	ro	Possible	
Index	Sub	Default	Range	Units	EEP-ROM	Parameter
2B92h	0		80000000h to 7FFFFFFFh	pulse	Impossible	

The load-side encoder information 1 at alarm occurrence is returned.

(49) Alarm Monitor 19 Load-side encoder information 2 (2B93h)

Index	Sub	Name	Data Type	Access	PDO Mapping	
2B93h	0	Alarm Monitor 19 Load-side encoder information 2	INTEGER32	ro	Possible	
Index	Sub	Default	Range	Units	EEP-ROM	Parameter
2B93h	0		80000000h to 7FFFFFFFh	rev	Impossible	

The load-side encoder information 2 at alarm occurrence is returned.

(50) Alarm Monitor 23 Temperature of motor thermistor (2B97h)

Index	Sub	Name	Data Type	Access	PDO Mapping	
2B97h	0	Alarm Monitor 23 Temperature of motor thermistor	INTEGER32	ro	Possible	
Index	Sub	Default	Range	Units	EEP-ROM	Parameter
2B97h	0		80000000h to 7FFFFFFFh	°C	Impossible	

The temperature of servo motor thermistor at alarm occurrence is returned.

18. EtherCAT COMMUNICATION

(51) Alarm Monitor 24 Motor-side cumu. feedback pulses (before gear) (2B98h)

Index	Sub	Name	Data Type	Access	PDO Mapping
2B98h	0	Alarm Monitor 24 Motor-side cumu. feedback pulses (before gear)	INTEGER32	ro	Possible

Index	Sub	Default	Range	Units	EEP-ROM	Parameter
2B98h	0		80000000h to 7FFFFFFFh	pulse	Impossible	

The cumulative feedback pulses (servo motor-side unit) at alarm occurrence are returned.

(52) Alarm Monitor 25 Electrical angle (2B99h)

Index	Sub	Name	Data Type	Access	PDO Mapping
2B99h	0	Alarm Monitor 25 Electrical angle	INTEGER32	ro	Possible

Index	Sub	Default	Range	Units	EEP-ROM	Parameter
2B99h	0		80000000h to 7FFFFFFFh	pulse	Impossible	

The electrical angle at alarm occurrence is returned.

(53) Alarm Monitor 35 Motor-side/load-side position deviation (2BA3h)

Index	Sub	Name	Data Type	Access	PDO Mapping
2BA3h	0	Alarm Monitor 35 Motor-side/load-side position deviation	INTEGER32	ro	Possible

Index	Sub	Default	Range	Units	EEP-ROM	Parameter
2BA3h	0		80000000h to 7FFFFFFFh	pulse	Impossible	

The motor-side/load-side position deviation at alarm occurrence is returned.

(54) Alarm Monitor 36 Motor-side/load-side speed deviation (2BA4h)

Index	Sub	Name	Data Type	Access	PDO Mapping
2BA4h	0	Alarm Monitor 36 Motor-side/load-side speed deviation	INTEGER32	ro	Possible

Index	Sub	Default	Range	Units	EEP-ROM	Parameter
2BA4h	0		80000000h to 7FFFFFFFh	r/min	Impossible	

The motor-side/load-side speed deviation at alarm occurrence is returned.

(55) Alarm Monitor 37 Internal temperature of encoder (2BA5h)

Index	Sub	Name	Data Type	Access	PDO Mapping
2BA5h	0	Alarm Monitor 37 Internal temperature of encoder	INTEGER32	ro	Possible

Index	Sub	Default	Range	Units	EEP-ROM	Parameter
2BA5h	0		80000000h to 7FFFFFFFh	°C	Impossible	

The internal temperature of encoder at alarm occurrence is returned.

18. EtherCAT COMMUNICATION

(56) Alarm Monitor 38 Settling time (2BA6h)

Index	Sub	Name		Data Type	Access	PDO Mapping
2BA6h	0	Alarm Monitor 38 Settling time		INTEGER32	ro	Possible
Index	Sub	Default	Range	Units	EEP-ROM	Parameter
2BA6h	0		80000000h to 7FFFFFFFh	ms	Impossible	

The settling time at alarm occurrence is returned.

(57) Alarm Monitor 39 Oscillation detection frequency (2BA7h)

Index	Sub	Name		Data Type	Access	PDO Mapping
2BA7h	0	Alarm Monitor 39 Oscillation detection frequency		INTEGER32	ro	Possible
Index	Sub	Default	Range	Units	EEP-ROM	Parameter
2BA7h	0		80000000h to 7FFFFFFFh	Hz	Impossible	

The oscillation detection frequency at alarm occurrence is returned.

(58) Alarm Monitor 40 Number of tough drive operations (2BA8h)

Index	Sub	Name		Data Type	Access	PDO Mapping
2BA8h	0	Alarm Monitor 40 Number of tough drive operations		INTEGER32	ro	Possible
Index	Sub	Default	Range	Units	EEP-ROM	Parameter
2BA8h	0		80000000h to 7FFFFFFFh	number of times	Impossible	

The number of tough drive operations at alarm occurrence is returned.

(59) Alarm Monitor 45 Unit power consumption (2BADh)

Index	Sub	Name		Data Type	Access	PDO Mapping
2BADh	0	Alarm Monitor 45 Unit power consumption		INTEGER32	ro	Possible
Index	Sub	Default	Range	Units	EEP-ROM	Parameter
2BADh	0		80000000h to 7FFFFFFFh	W	Impossible	

The unit power consumption at alarm occurrence is returned.

(60) Alarm Monitor 46 Unit total power consumption (2BAEh)

Index	Sub	Name		Data Type	Access	PDO Mapping
2BAEh	0	Alarm Monitor 46 Unit total power consumption		INTEGER32	ro	Possible
Index	Sub	Default	Range	Units	EEP-ROM	Parameter
2BAEh	0		80000000h to 7FFFFFFFh	Wh	Impossible	

The unit total power consumption at alarm occurrence is returned.

18. EtherCAT COMMUNICATION

(61) Alarm Monitor 47 Current position (2BAFh)

Index	Sub	Name		Data Type	Access	PDO Mapping
2BAFh	0	Alarm Monitor 47 Current position		INTEGER32	ro	Possible
Index	Sub	Default	Range	Units	EEP-ROM	Parameter
2BAFh	0		80000000h to 7FFFFFFFh	pos units	Impossible	

The current position at alarm occurrence is returned. In the indexer method, the value is fixed to 0.
This object is available with drivers

(62) Alarm Monitor 48 Command position (2BB0h)

Index	Sub	Name		Data Type	Access	PDO Mapping
2BB0h	0	Alarm Monitor 48 Command position		INTEGER32	ro	Possible
Index	Sub	Default	Range	Units	EEP-ROM	Parameter
2BB0h	0		80000000h to 7FFFFFFFh	pos units	Impossible	

The command position at alarm occurrence is returned. In the indexer method, the value is fixed to 0.
This object is available with drivers

(63) Alarm Monitor 49 Command remaining distance (2BB1h)

Index	Sub	Name		Data Type	Access	PDO Mapping
2BB1h	0	Alarm Monitor 49 Command remaining distance		INTEGER32	ro	Possible
Index	Sub	Default	Range	Units	EEP-ROM	Parameter
2BB1h	0		80000000h to 7FFFFFFFh	pos units	Impossible	

The command remaining distance at alarm occurrence is returned.
This object is available with drivers

(64) Alarm Monitor 50 Point table No./Program No./Station position No. (2BB2h)

Index	Sub	Name		Data Type	Access	PDO Mapping
2BB2h	0	Alarm Monitor 50 Point table No./Program No./ Station position No.		INTEGER16	ro	Possible
Index	Sub	Default	Range	Units	EEP-ROM	Parameter
2BB2h	0		0000h to 00FFh		Impossible	

Point table No. or station position No. at alarm occurrence is returned.
This object is available with drivers

18. EtherCAT COMMUNICATION

18.7.3.7 Manufacturer Specific Control Objects

(1) External Output pin display (2C11h)

Index	Sub	Name	Data Type	Access	PDO Mapping
2C11h	0	Number of entries	UNSIGNED8	ro	Impossible
	1	External Output pin display1	INTEGER32	ro	

Index	Sub	Default	Range	Units	EEP-ROM	Parameter
2C11h	0	2	02h to 02h		Impossible	
	1	0	00000000h to 0000000Fh			

The ON/OFF state of external output pins output from the driver can be read.
This object is available with drivers.

The following shows the detail of External Output pin display1. When the output of the target pin is on, "1" is returned. When the output of the target pin is off, "0" is returned. The values in the areas marked with diagonal lines at reading is undefined.

Bit	CN3 connector pin	Bit	CN3 connector pin	Bit	CN3 connector pin	Bit	CN3 connector pin
0	13	8		16		24	
1	15	9		17		25	
2	9	10		18		26	
3	8	11		19		27	
4		12		20		28	
5		13		21		29	
6		14		22		30	
7		15		23		31	

(2) Power ON cumulative time (2C18h)

Index	Sub	Name	Data Type	Access	PDO Mapping
2C18h	0	Power ON cumulative time	UNSIGNED32	ro	Impossible

Index	Sub	Default	Range	Units	EEP-ROM	Parameter
2C18h	0		00000000h to FFFFFFFFh	hour	Impossible	

The cumulative energization time of the driver is returned.
This object is available with drivers.

(3) Number of inrush relay on/off times (2C19h)

Index	Sub	Name	Data Type	Access	PDO Mapping
2C19h	0	Number of inrush relay on/off times	UNSIGNED32	ro	Impossible

Index	Sub	Default	Range	Units	EEP-ROM	Parameter
2C19h	0		00000000h to FFFFFFFFh	number of times	Impossible	

The number of on/off times of the inrush relay of the driver is returned.
This object is available with drivers.

18. EtherCAT COMMUNICATION

(4) Machine diagnostic status (2C20h)

Index	Sub	Name	Data Type	Access	PDO Mapping
2C20h	0	Machine diagnostic status	UNSIGNED16	ro	Impossible

Index	Sub	Default	Range	Units	EEP-ROM	Parameter
2C20h	0		Refer to the text.		Impossible	

The machine diagnostic status is returned. The description is as follows.

This object is available with drivers.

Bit	Description
0 to 3	Friction estimation status at forward rotation 0: Friction is being estimated. (normal) 1: Estimation is completed. (normal) 2: The servo motor may rotate in one direction too frequently. (warning) 3: The servo motor speed may too slow for friction estimation. (warning) 4: The change in the servo motor speed may be small for friction estimation. (warning) 5: The acceleration/deceleration time constants may be too short for friction estimation. (warning) 6: The operation time may not be enough. (warning) When warning conditions for 2 to 6 are met at the same time, the smaller number is returned. When an estimation is completed even though a warning has once occurred, the status changes to Estimation is completed.
4 to 7	Friction estimation status at reverse rotation 0: Friction is being estimated. (normal) 1: Estimation is completed. (normal) 2: The servo motor may rotate in one direction too frequently. (warning) 3: The servo motor speed may too slow for friction estimation. (warning) 4: The change in the servo motor speed may be small for friction estimation. (warning) 5: The acceleration/deceleration time constants may be too short for friction estimation. (warning) 6: The operation time may not be enough. (warning) When warning conditions for 2 to 6 are met at the same time, the smaller number is returned. When an estimation is completed even though a warning has once occurred, the status changes to Estimation is completed.
8 to 11	Vibration estimation status 0: During estimation 1: Estimation is completed.
12 to 15	(reserved) The value at reading is undefined.

(5) Static friction torque at forward rotation (2C21h)

Index	Sub	Name	Data Type	Access	PDO Mapping
2C21h	0	Static friction torque at forward rotation	INTEGER16	ro	Impossible

Index	Sub	Default	Range	Units	EEP-ROM	Parameter
2C21h	0		8000h to 7FFFh	0.1%	Impossible	

Static friction torque at forward rotation is returned in increments of 0.1%.

This object is available with drivers.

18. EtherCAT COMMUNICATION

(6) Dynamic friction torque at forward rotation (at rated speed) (2C22h)

Index	Sub	Name	Data Type	Access	PDO Mapping
2C22h	0	Dynamic friction torque at forward rotation (at rated speed)	INTEGER16	ro	Impossible

Index	Sub	Default	Range	Units	EEP-ROM	Parameter
2C22h	0		8000h to 7FFFh	0.1%	Impossible	

Dynamic friction torque at forward rotation at the rated speed is returned in increments of 0.1%.

This object is available with drivers.

(7) Static friction torque at reverse rotation (2C23h)

Index	Sub	Name	Data Type	Access	PDO Mapping
2C23h	0	Static friction torque at reverse rotation	INTEGER16	ro	Impossible

Index	Sub	Default	Range	Units	EEP-ROM	Parameter
2C23h	0		8000h to 7FFFh	0.1%	Impossible	

Static friction torque at reverse rotation is returned in increments of 0.1%.

This object is available with drivers.

(8) Dynamic friction torque at reverse rotation (at rated speed) (2C24h)

Index	Sub	Name	Data Type	Access	PDO Mapping
2C24h	0	Dynamic friction torque at reverse rotation (at rated speed)	INTEGER16	ro	Impossible

Index	Sub	Default	Range	Units	EEP-ROM	Parameter
2C24h	0		8000h to 7FFFh	0.1%	Impossible	

Dynamic friction torque at reverse rotation at rated speed is returned in increments of 0.1%.

This object is available with drivers.

(9) Oscillation frequency during motor stop (2C25h)

Index	Sub	Name	Data Type	Access	PDO Mapping
2C25h	0	Oscillation frequency during motor stop	INTEGER16	ro	Impossible

Index	Sub	Default	Range	Units	EEP-ROM	Parameter
2C25h	0		8000h to 7FFFh	Hz	Impossible	

Vibration frequency during stop/servo-lock is returned in increments of 1 Hz.

This object is available with drivers.

(10) Vibration level during motor stop (2C26h)

Index	Sub	Name	Data Type	Access	PDO Mapping
2C26h	0	Vibration level during motor stop	INTEGER16	ro	Impossible

Index	Sub	Default	Range	Units	EEP-ROM	Parameter
2C26h	0		8000h to 7FFFh	0.1%	Impossible	

Vibration level during stop/servo-lock is returned in increments of 0.1%.

This object is available with drivers.

18. EtherCAT COMMUNICATION

(11) Oscillation frequency during motor operating (2C27h)

Index	Sub	Name		Data Type	Access	PDO Mapping
2C27h	0	Oscillation frequency during motor operating		INTEGER16	ro	Impossible
Index	Sub	Default	Range	Units	EEP-ROM	Parameter
2C27h	0		8000h to 7FFFh	Hz	Impossible	

Vibration frequency during operation is returned in increments of 1 Hz.
This object is available with drivers.

(12) Vibration level during motor operating (2C28h)

Index	Sub	Name		Data Type	Access	PDO Mapping
2C28h	0	Vibration level during motor operating		INTEGER16	ro	Impossible
Index	Sub	Default	Range	Units	EEP-ROM	Parameter
2C28h	0		8000h to 7FFFh	0.1%	Impossible	

Vibration level during operation is returned in increments of 0.1%.
This object is available with drivers

(13) Control DI 1 (2D01h)

Index	Sub	Name		Data Type	Access	PDO Mapping
2D01h	0	Control DI 1		UNSIGNED16	rw	Possible
Index	Sub	Default	Range	Units	EEP-ROM	Parameter
2D01h	0	0	Refer to the text.		Impossible	

Set control commands to control the driver. Refer to section 5.2.2 (1) for details.

(14) Control DI 2 (2D02h)

Index	Sub	Name		Data Type	Access	PDO Mapping
2D02h	0	Control DI 2		UNSIGNED16	rw	Possible
Index	Sub	Default	Range	Units	EEP-ROM	Parameter
2D02h	0	0	Refer to the text.		Impossible	

Set control commands to control the driver. Refer to section 5.2.2 (2) for details.

(15) Control DI 3 (2D03h)

Index	Sub	Name		Data Type	Access	PDO Mapping
2D03h	0	Control DI 3		UNSIGNED16	rw	Possible
Index	Sub	Default	Range	Units	EEP-ROM	Parameter
2D03h	0	0	Refer to the text.		Impossible	

Set control commands to control the driver. Refer to section 5.2.2 (3) for details.

18. EtherCAT COMMUNICATION

(16) Status DO 1 (2D11h)

Index	Sub	Name	Data Type	Access	PDO Mapping	
2D11h	0	Status DO 1	UNSIGNED16	ro	Possible	
Index	Sub	Default	Range	Units	EEP-ROM	Parameter
2D11h	0		Refer to the text.		Impossible	

The servo status is returned. Refer to section 5.3.2 (1) for details.

(17) Status DO 2 (2D12h)

Index	Sub	Name	Data Type	Access	PDO Mapping	
2D12h	0	Status DO 2	UNSIGNED16	ro	Possible	
Index	Sub	Default	Range	Units	EEP-ROM	Parameter
2D12h	0		Refer to the text.		Impossible	

The servo status is returned. Refer to section 5.3.2 (2) for details.

(18) Status DO 3 (2D13h)

Index	Sub	Name	Data Type	Access	PDO Mapping	
2D13h	0	Status DO 3	UNSIGNED16	ro	Possible	
Index	Sub	Default	Range	Units	EEP-ROM	Parameter
2D13h	0		Refer to the text.		Impossible	

The servo status is returned. Refer to section 5.3.2 (3) for details.

(19) Status DO 5 (2D15h)

Index	Sub	Name	Data Type	Access	PDO Mapping	
2D15h	0	Status DO 5	UNSIGNED16	ro	Possible	
Index	Sub	Default	Range	Units	EEP-ROM	Parameter
2D15h	0		Refer to the text.		Impossible	

The servo status is returned. Refer to section 5.3.2 (4) for details.

(20) Status DO 7 (2D17h)

Index	Sub	Name	Data Type	Access	PDO Mapping	
2D17h	0	Status DO 7	UNSIGNED16	ro	Possible	
Index	Sub	Default	Range	Units	EEP-ROM	Parameter
2D17h	0		Refer to the text.		Impossible	

The servo status is returned. Refer to section 5.3.2 (5) for details.

18. EtherCAT COMMUNICATION

(21) Velocity limit value (2D20h)

Index	Sub	Name	Data Type	Access	PDO Mapping
2D20h	0	Velocity limit value	UNSIGNED32	rw	Possible

Index	Sub	Default	Range	Units	EEP-ROM	Parameter
2D20h	0	50000	00000000h to instantaneous permissible speed	vel units	Possible	PT67

Set the speed limit value of the cyclic synchronous torque mode (cst) and the profile torque mode (tq).
Unit: [0.01 r/min] ([0.01 mm/s] when a linear servo motor is used)

(22) Watch dog counter DL (2D23h)

Index	Sub	Name	Data Type	Access	PDO Mapping
2D23h	0	Watch dog counter DL	UNSIGNED8	rw	Possible

Index	Sub	Default	Range	Units	EEP-ROM	Parameter
2D23h	0		00h to FFh		Impossible	

When this object is mapped for RxPDO, set a value so that the counter is incremented by 1 per communication cycle. If the value is not updated correctly in the _ driver, [AL. 86.2 Network communication error 2] occurs.

(23) Watch dog counter UL (2D24h)

Index	Sub	Name	Data Type	Access	PDO Mapping
2D24h	0	Watch dog counter UL	UNSIGNED8	ro	Possible

Index	Sub	Default	Range	Units	EEP-ROM	Parameter
2D24h	0		00h to FFh		Impossible	

This counter is incremented by 1 per communication cycle. The sum of the value of Watch dog counter DL (2D23h) and 1 is returned.

(24) Motor rated speed (2D28h)

Index	Sub	Name	Data Type	Access	PDO Mapping
2D28h	0	Motor rated speed	UNSIGNED32	ro	Impossible

Index	Sub	Default	Range	Units	EEP-ROM	Parameter
2D28h	0		00000000h to FFFFFFFFh	r/min	Impossible	

The servo motor rated speed is returned.
Unit: [r/min] ([mm/s] when a linear servo motor is used)

(25) Manufacturer Device Name 2 (2D30h)

Index	Sub	Name	Data Type	Access	PDO Mapping
2D30h	0	Manufacturer Device Name 2	VISIBLE STRING	ro	Impossible

Index	Sub	Default	Range	Units	EEP-ROM	Parameter
2D30h	0				Impossible	

The model name of the driver is returned.

18. EtherCAT COMMUNICATION

(26) Manufacturer Hardware Version 2 (2D31h)

Index	Sub	Name	Data Type	Access	PDO Mapping
2D31h	0	Manufacturer Hardware Version 2	VISIBLE STRING	ro	Impossible

Index	Sub	Default	Range	Units	EEP-ROM	Parameter
2D31h	0				Impossible	

The hardware version of the driver is returned.

(27) Manufacturer Software Version 2 (2D32h)

Index	Sub	Name	Data Type	Access	PDO Mapping
2D32h	0	Manufacturer Software Version 2	VISIBLE STRING	ro	Impossible

Index	Sub	Default	Range	Units	EEP-ROM	Parameter
2D32h	0				Impossible	

The software version of the driver is returned.

(28) Serial Number 2 (2D33h)

Index	Sub	Name	Data Type	Access	PDO Mapping
2D33h	0	Serial Number 2	VISIBLE STRING	ro	Impossible

Index	Sub	Default	Range	Units	EEP-ROM	Parameter
2D33h	0				Impossible	

The serial number of the driver is returned.

(29) User parameter configuration (2D34h)

Index	Sub	Name	Data Type	Access	PDO Mapping
2D34h	0	User parameter configuration	UNSIGNED16	rw	Impossible

Index	Sub	Default	Range	Units	EEP-ROM	Parameter
2D34h	0	1	Refer to the text.		Impossible	

The parameters whose symbols are preceded by * are not automatically enabled. Writing "1EA5h" to this object enables the parameters. This operation can be performed only in the Pre-Operational state.

The read values of this object are as follows. The completion of the parameter enables processing can be checked.

Value	Description
0	Parameter enabling processing is being executed.
1	Parameter enabling processing is not being executed. (The processing is completed.)

18. EtherCAT COMMUNICATION

(30) Encoder status (2D35h)

Index	Sub	Name	Data Type	Access	PDO Mapping
2D35h	0	Encoder status	UNSIGNED8	ro	Impossible
	1	Encoder status1	UNSIGNED32		
	2	Encoder status2			

Index	Sub	Default	Range	Units	EEP-ROM	Parameter
2D35h	0	2	02h to 02h		Impossible	
	1		00000000h to 00000001h			
	2		00000000h to 00000007h			

The status of the encoder is returned. The description of each Sub Index is as follows.

This object is available with drivers.

Sub	Name	Description
0	Encoder status	Number of entries
1	Encoder status1	The status of the encoder is returned. For a fully closed loop system, the external encoder status is returned. Bit 0: Whether the driver is used in an absolute position detection system or not is returned. 0 = Incremental system 1 = Absolute position detection system Bit 1 to Bit 31: Reserved
2	Encoder status2	The status of the scale measurement encoder is returned. Bit 0: Whether the driver is used in an absolute position detection system or not is returned. 0 = Incremental system 1 = Absolute position detection system Bit 1: Whether the scale measurement function is enabled or disabled is returned. 0 = Disabled 1 = Enabled Bit 2: Whether the connected scale measurement encoder is the absolute position type or not is returned. 0 = Incremental type 1 = Absolute position type Bit 3 to Bit 31: Reserved

(31) Scale cycle counter (2D36h)

Index	Sub	Name	Data Type	Access	PDO Mapping
2D36h	0	Scale cycle counter	UNSIGNED32	ro	Possible

Index	Sub	Default	Range	Units	EEP-ROM	Parameter
2D36h	0		00000000h to FFFFFFFFh	pulse	Impossible	

The position within one-revolution of the scale measurement encoder is returned. Returned values differ depending on the scale measurement encoder type.

This object is available with drivers

Scale measurement encoder	Description
Rotary encoder	Cycle counter
Linear encoder Absolute position type	ABS counter
Linear encoder Incremental type	Scale coasting counter
Linear encoder A/B/Z-phase differential output type	Scale coasting counter

18. EtherCAT COMMUNICATION

Incremental type	
------------------	--

(32) Scale ABS counter (2D37h)

Index	Sub	Name	Data Type	Access	PDO Mapping
2D37h	0	Scale ABS counter	INTEGER32	ro	Possible

Index	Sub	Default	Range	Units	EEP-ROM	Parameter
2D37h	0		80000000h to 7FFFFFFFh	rev	Impossible	

The ABS counter of the scale measurement encoder is returned. Returned values differ depending on the scale measurement encoder type.

This object is available with drivers.

Scale measurement encoder	Description
Rotary encoder	Multi-revolution ABS counter
Linear encoder Absolute position type	Fixed to 0
Linear encoder Incremental type	Fixed to 0
Linear encoder A/B/Z-phase differential output type Incremental type	Fixed to 0

(33) Scale measurement encoder resolution (2D38h)

Index	Sub	Name	Data Type	Access	PDO Mapping
2D38h	0	Scale measurement encoder resolution	UNSIGNED32	ro	Impossible

Index	Sub	Default	Range	Units	EEP-ROM	Parameter
2D38h	0		00000000h to FFFFFFFFh	inc/rev	Impossible	

The resolution of the scale measurement encoder is returned.

This object is available with drivers.

(34) Scale measurement encoder reception status (2D3Ch)

Index	Sub	Name	Data Type	Access	PDO Mapping
2D3Ch	0	Scale measurement encoder reception status	UNSIGNED32	ro	Possible

Index	Sub	Default	Range	Units	EEP-ROM	Parameter
2D3Ch	0		00000000h to FFFFFFFFh		Impossible	

The alarm data of the scale measurement encoder is returned. The value "0" indicates that no error occurs. A value other than "0" indicates that an error occurs.

This object is available with drivers

18. EtherCAT COMMUNICATION

(35) One-touch tuning mode (2D50h)

Index	Sub	Name	Data Type	Access	PDO Mapping
2D50h	0	One-touch tuning mode	UNSIGNED8	rw	Impossible

Index	Sub	Default	Range	Units	EEP-ROM	Parameter
2D50h	0		00h to 03h		Impossible	

Setting a value of "1" to "3" starts one-touch tuning. After one-touch tuning is completed, the setting value automatically changes to "0". The description of the setting values is as follows.

This object is available with drivers

Setting value	Description
0	During one-touch tuning stop
1	Basic mode
2	High mode
3	Low mode

(36) One-touch tuning status (2D51h)

Index	Sub	Name	Data Type	Access	PDO Mapping
2D51h	0	One-touch tuning status	INTEGER8	ro	Impossible

Index	Sub	Default	Range	Units	EEP-ROM	Parameter
2D51h	0		00h to 64h	%	Impossible	

The one-touch tuning progress is returned.

This object is available with drivers

(37) One-touch tuning Stop (2D52h)

Index	Sub	Name	Data Type	Access	PDO Mapping
2D52h	0	One-touch tuning Stop	UNSIGNED16	wo	Impossible

Index	Sub	Default	Range	Units	EEP-ROM	Parameter
2D52h	0		0000h/1EA5h		Impossible	

Writing "1EA5h" can stop one-touch tuning. Writing any value other than "1EA5h" causes SDO Abort Code (0609 0030h Value range of parameter exceeded).

This object is available with drivers

18. EtherCAT COMMUNICATION

(38) One-touch tuning Clear (2D53h)

Index	Sub	Name	Data Type	Access	PDO Mapping
2D53h	0	One-touch tuning Clear	UNSIGNED16	wo	Impossible

Index	Sub	Default	Range	Units	EEP-ROM	Parameter
2D53h	0		0000h to 0001h		Impossible	

The parameter changed in one-touch tuning can be returned to the value before the change. The description of the setting values is as follows.

This object is available with drivers

Setting value	Description
0000h	Restores the initial value.
0001h	Restores the value before one-touch tuning.

(39) One-touch tuning Error Code (2D54h)

Index	Sub	Name	Data Type	Access	PDO Mapping
2D54h	0	One-touch tuning Error Code	UNSIGNED16	ro	Impossible

Index	Sub	Default	Range	Units	EEP-ROM	Parameter
2D54h	0		0000h to C00Fh		Impossible	

An error code of the one-touch tuning is returned. The description of the error codes is as follows.

This object is available with drivers

Error code	Description
0000h	Finished normally
C000h	Tuning canceled
C001h	Overshoot exceeded
C002h	Servo-off during tuning
C003h	Control mode error
C004h	Time-out
C005h	Load to motor inertia ratio misestimated
C00Fh	One-touch tuning disabled

(40) Torque limit value 2 (2D6Bh)

Index	Sub	Name	Data Type	Access	PDO Mapping
2D6Bh	0	Torque limit value 2	UNSIGNED16	rw	Possible

Index	Sub	Default	Range	Units	EEP-ROM	Parameter
2D6Bh	0	10000	0000h to 2710h	per thousand of rated torque	Impossible	

The generated torque at a servo motor stop in the indexer method can be limited. Set this parameter to "0" to generate no torque.

This object is available with drivers

18. EtherCAT COMMUNICATION

18.7.3.8 PDS Control Objects

(1) Error code (603Fh)

Index	Sub	Name	Data Type	Access	PDO Mapping
603Fh	0	Error code	UNSIGNED16	ro	Possible

Index	Sub	Default	Range	Units	EEP-ROM	Parameter
603Fh	0	0	0000h to FFFFh		Impossible	

The number of the latest error that occurred after the power on is returned. The description of the error number is the same as that of Pre-defined error field (1003h). Refer to section 7.3.1 (3).

(2) Controlword (6040h)

Index	Sub	Name	Data Type	Access	PDO Mapping
6040h	0	Controlword	UNSIGNED16	rw	Possible

Index	Sub	Default	Range	Units	EEP-ROM	Parameter
6040h	0	0	Refer to the text.		Impossible	

Set control commands to control the driver. Refer to section 5.2.1 for details.

(3) Statusword (6041h)

Index	Sub	Name	Data Type	Access	PDO Mapping
6041h	0	Statusword	UNSIGNED16	ro	Possible

Index	Sub	Default	Range	Units	EEP-ROM	Parameter
6041h	0		Refer to the text.		Impossible	

The servo status is returned. Refer to section 5.3.1 for details.

(4) Quick stop option code (605Ah)

Index	Sub	Name	Data Type	Access	PDO Mapping
605Ah	0	Quick stop option code	INTEGER16	rw	Impossible

Index	Sub	Default	Range	Units	EEP-ROM	Parameter
605Ah	0	2	0002h to 0002h		Possible	PT68

Set how to decelerate the servo motor to a stop at Quick Stop reception. The description of the setting values is as follows.

Setting value	Description
1	
2	In the cyclic synchronous mode (csp/csv), profile mode (pp/pv), and homing mode (hm), the servo motor decelerates to a stop with Quick stop deceleration (6085h) and the state shifts to the Switch On Disabled state. In the cyclic synchronous torque mode (cst) and profile torque mode (tq), the state immediately shifts to the Switch On Disabled state and the servo motor stops with the dynamic brake.
3	
4	
5	
6	
7	
8	

18. EtherCAT COMMUNICATION

(5) Halt option code (605Dh)

Index	Sub	Name	Data Type	Access	PDO Mapping
605Dh	0	Halt option code	INTEGER16	rw	Impossible

Index	Sub	Default	Range	Units	EEP-ROM	Parameter
605Dh	0	1	0001h to 0001h		Possible	PT68

Set how to decelerate the servo motor to a stop at Halt reception. The description of the setting values is as follows.

Setting value	Description
1	For Profile deceleration (6084h) and the homing mode (hm), the servo motor decelerates to a stop according to Homing acceleration (609Ah) and the state does not change from the Operation Enabled state (servo-on).
2	
3	
4	

(6) Modes of operation (6060h)

Index	Sub	Name	Data Type	Access	PDO Mapping
6060h	0	Modes of operation	INTEGER8	rw	Possible

Index	Sub	Default	Range	Units	EEP-ROM	Parameter
6060h	0	0	Refer to the text.		Impossible	

Set the control mode. The setting values are as follows.

Setting value	Description
0	No mode change/No mode assigned
1	Profile position mode (pp)
3	Profile velocity mode (pv)
4	Profile torque mode (tq)
6	Homing mode (hm)
8	Cyclic synchronous position mode (csp)
9	Cyclic synchronous velocity mode (csv)
10	Cyclic synchronous torque mode (cst)
-100	Jog mode (jg)
-101	Point table mode (pt)
-103	Indexer mode (idx)

The settable values are limited depending on the setting of [Pr. PA01]. Refer to section 5.4.1 for details.

18. EtherCAT COMMUNICATION

(7) Modes of operation display (6061h)

Index	Sub	Name	Data Type	Access	PDO Mapping
6061h	0	Modes of operation display	INTEGER8	ro	Possible

Index	Sub	Default	Range	Units	EEP-ROM	Parameter
6061h	0	0	Refer to the text.		Impossible	

The current control mode is returned. The description is as follows.

Setting value	Description
0	No mode assigned
1	Profile position mode (pp)
3	Profile velocity mode (pv)
4	Profile torque mode (tq)
6	Homing mode (hm)
8	Cyclic synchronous position mode (csp)
9	Cyclic synchronous velocity mode (csv)
10	Cyclic synchronous torque mode (cst)
-100	Jog mode (jg)
-101	Point table mode (pt)
-103	Indexer mode (idx)

The default values vary depending on the setting value of [Pr. PA01].

Setting value of [Pr. PA01]	Default value
___0	8 (csp)
___1	1 (pp)
___2	1 (pp)
___6	-101 (pt)
___8	-103 (idx)

18. EtherCAT COMMUNICATION

(8) Supported drive modes (6502h)

Index	Sub	Name	Data Type	Access	PDO Mapping
6502h	0	Supported drive modes	UNSIGNED32	ro	Possible

Index	Sub	Default	Range	Units	EEP-ROM	Parameter
6502h	0	Refer to the text.	Refer to the text.		Impossible	

The supported control mode is returned. The description is as follows.

Bit	Description	Defined value
0	Profile position mode (pp)	1: Supported
1	Velocity mode (vl)	0
2	Profile velocity mode (pv)	1: Supported
3	Profile torque mode (tq)	1: Supported
4	Reserved	0
5	Homing mode (hm)	1: Supported
6	Interpolated position mode (ip)	0
7	Cyclic synchronous position mode (csp)	1: Supported
8	Cyclic synchronous velocity mode (csv)	1: Supported
9	Cyclic synchronous torque mode (cst)	1: Supported
10	Cyclic synchronous torque mode with communication angle (cstca)	0
11 to 15	Reserved	0
16	Jog mode (jg)	1: Supported
17	Point table mode (pt)	1: Supported
18	Reserved	0
19	Indexer mode (idx)	1: Supported
20 to 31	Reserved	0

The fixed value is returned regardless of the setting of [Pr. PA01]. However, the usable control modes are limited depending on the setting of [Pr. PA01]. Refer to section 5.4.1 for details.

18. EtherCAT COMMUNICATION

18.7.3.9 Position Control Function Objects

(1) Position actual internal value (6063h)

Index	Sub	Name	Data Type	Access	PDO Mapping
6063h	0	Position actual internal value	INTEGER32	ro	Possible

Index	Sub	Default	Range	Units	EEP-ROM	Parameter
6063h	0		80000000h to 7FFFFFFFh	inc	Impossible	

The current position is returned.

(2) Position actual value (6064h)

Index	Sub	Name	Data Type	Access	PDO Mapping
6064h	0	Position actual value	INTEGER32	ro	Possible

Index	Sub	Default	Range	Units	EEP-ROM	Parameter
6064h	0		80000000h to 7FFFFFFFh	pos units	Impossible	

The current position in the command unit is returned. In the indexer method, "0" is returned.

(3) Following error window (6065h)

Index	Sub	Name	Data Type	Access	PDO Mapping
6065h	0	Following error window	UNSIGNED32	rw	Possible

Index	Sub	Default	Range	Units	EEP-ROM	Parameter
6065h	0	00C00000h	00000000h to FFFFFFFFh	pos units	Possible	PC67/PC68

In the profile position mode (pp), cyclic synchronous position mode (csp), point table mode (pt), Jog mode (jg) or indexer mode (idx) when the time set with Following error time out (6066h) has elapsed with the number of droop pulses exceeding the setting value of this object, Bit 13 of Statusword (6041h) is turned on. When "FFFFFFFh" is set, Bit 13 of Statusword (6041h) is always off.

(4) Following error time out (6066h)

Index	Sub	Name	Data Type	Access	PDO Mapping
6066h	0	Following error time out	UNSIGNED16	rw	Possible

Index	Sub	Default	Range	Units	EEP-ROM	Parameter
6066h	0	10	0000h to FFFFh	ms	Possible	PC69

Refer to Following error window (6065h).

18. EtherCAT COMMUNICATION

(5) Position window (6067h)

Index	Sub	Name	Data Type	Access	PDO Mapping
6067h	0	Position window	UNSIGNED32	rw	Possible

Index	Sub	Default	Range	Units	EEP-ROM	Parameter
6067h	0	100	Refer to the text.	pos units	Possible	PC70

The description of this object is as follows.

Setting value	Description
00000000h to 0000FFFEh	In the profile position mode (pp), point table mode (pt) or Jog mode (jg), when the time set with Position windows time (6068h) has elapsed with the number of droop pulses equal to or lower than the setting value of this object, Bit 10 of Statusword (6041h) is turned on.
0000FFFFh to FFFFFFFEh	Unsettable
FFFFFFFFh	Bit 10 of Statusword (6041h) is always on in the profile position mode (pp), point table mode (pt) or Jog mode (jg).

(6) Position window time (6068h)

Index	Sub	Name	Data Type	Access	PDO Mapping
6068h	0	Position window time	UNSIGNED16	rw	Possible

Index	Sub	Default	Range	Units	EEP-ROM	Parameter
6068h	0	10	0000h to FFFFh	ms	Possible	PC71

Refer to Position window (6067h).

18. EtherCAT COMMUNICATION

(7) Positioning option code (60F2h)

Index	Sub	Name	Data Type	Access	PDO Mapping
60F2h	0	Positioning option code	UNSIGNED16	rw	Possible

Index	Sub	Default	Range	Units	EEP-ROM	Parameter
60F2h	0	0000h	0000h to 00C0h		Possible	PT03

Set the profile position mode (pp). The description of this object is as follows.

Bit	Description	Defined value
0 to 1	00b: The positioning is performed with the relative position from the internal absolute target position. 01b: The positioning is performed with the relative position from Position demand actual value (60FCh). (Not supported) (Note 1) 10b: The positioning is performed with the relative position from Position actual value (6064h). (not supported) (Note 1) 11b: reserved	00b
2 to 3	00b: New values of Target position (607Ah), Profile velocity (6081h), and Acceleration are promptly reflected. 01b: The current positioning continues to reach the target position. Then a new setting of Target position (607Ah), Profile velocity (6081h), and Acceleration is applied. (not supported) (Note 1) 10b: reserved 11b: reserved	00b
4 to 5	Reserved	0
6 to 7	00b: The servo motor rotates to the target position in a direction specified with a sign of the position data. 01b: The servo motor rotates in the address decreasing direction regardless of the sign of the position data. 10b: The servo motor rotates in the address increasing direction regardless of the sign of the position data. 11b: The servo motor rotates from the current position to the target position in the shorter direction. If the distances from the current position to the target position are the same for CCW and CW, the servo motor rotates in the CCW direction.	00b
8 to 15	Reserved	0

Note 1. This is not supported by the driver.

(8) Following error actual value (60F4h)

Index	Sub	Name	Data Type	Access	PDO Mapping
60F4h	0	Following error actual value	INTEGER32	ro	Possible

Index	Sub	Default	Range	Units	EEP-ROM	Parameter
60F4h	0		80000000h to 7FFFFFFFh	pos units	Impossible	

The droop pulses are returned.

(9) Control effort (60FAh)

Index	Sub	Name	Data Type	Access	PDO Mapping
60FAh	0	Control effort	INTEGER32	ro	Possible

Index	Sub	Default	Range	Units	EEP-ROM	Parameter
60FAh	0		80000000h to 7FFFFFFFh	vel units	Impossible	

The speed command is returned.

Unit: [0.01 r/min]

18. EtherCAT COMMUNICATION

18. 7. 3. 10 Profile Velocity Mode Objects

(1) Velocity demand value (606Bh)

Index	Sub	Name	Data Type	Access	PDO Mapping
606Bh	0	Velocity demand value	INTEGER32	ro	Possible

Index	Sub	Default	Range	Units	EEP-ROM	Parameter
606Bh	0		80000000h to 7FFFFFFFh	vel units	Impossible	

The speed command is returned.

Unit: [0.01 r/min]

(2) Velocity actual value (606Ch)

Index	Sub	Name	Data Type	Access	PDO Mapping
606Ch	0	Velocity actual value	INTEGER32	ro	Possible

Index	Sub	Default	Range	Units	EEP-ROM	Parameter
606Ch	0		80000000h to 7FFFFFFFh	vel units	Impossible	

The current speed is returned.

Unit: [0.01 r/min]

(3) Velocity window (606Dh)

Index	Sub	Name	Data Type	Access	PDO Mapping
606Dh	0	Velocity window	UNSIGNED16	rw	Possible

Index	Sub	Default	Range	Units	EEP-ROM	Parameter
606Dh	0	2000	0000h to FFFFh	vel units	Possible	PC72

In the profile velocity mode (pv), when the time set with Velocity window time (606Eh) has elapsed with the current speed equal to or lower than the setting value of this object, Bit 10 of Statusword (6041h) is turned on.

Unit: [0.01 r/min]

(4) Velocity window time (606Eh)

Index	Sub	Name	Data Type	Access	PDO Mapping
606Eh	0	Velocity window time	UNSIGNED16	rw	Possible

Index	Sub	Default	Range	Units	EEP-ROM	Parameter
606Eh	0	10	0000h to FFFFh	ms	Possible	PC73

Refer to Velocity window (606Dh).

18. EtherCAT COMMUNICATION

(5) Velocity threshold (606Fh)

Index	Sub	Name	Data Type	Access	PDO Mapping
606Fh	0	Velocity threshold	UNSIGNED16	rw	Possible

Index	Sub	Default	Range	Units	EEP-ROM	Parameter
606Fh	0	5000	0000h to FFFFh	vel units	Possible	PC65

In the profile velocity mode (pv), when the time set with Velocity threshold time (6070h) has elapsed with the current speed higher than the setting value of this object, Bit 12 of Statusword (6041h) is turned off.

Unit: [0.01 r/min]

(6) Velocity threshold time (6070h)

Index	Sub	Name	Data Type	Access	PDO Mapping
6070h	0	Velocity threshold time	UNSIGNED16	rw	Possible

Index	Sub	Default	Range	Units	EEP-ROM	Parameter
6070h	0	10	0000h to FFFFh	ms	Possible	PC66

Refer to Velocity threshold (606Fh).

(7) Target velocity (60FFh)

Index	Sub	Name	Data Type	Access	PDO Mapping
60FFh	0	Target velocity	INTEGER32	rw	Possible

Index	Sub	Default	Range	Units	EEP-ROM	Parameter
60FFh	0	0	80000000h to 7FFFFFFFh	vel units	Impossible	

Set the speed command used in the cyclic synchronous velocity mode (csv) and the profile velocity mode (pv).

Unit: [0.01 r/min]

18. EtherCAT COMMUNICATION

18.7.3.11 Profile Torque Mode Objects

(1) Target torque (6071h)

Index	Sub	Name		Data Type	Access	PDO Mapping
6071h	0	Target torque		INTEGER16	rw	Possible
Index	Sub	Default	Range	Units	EEP-ROM	Parameter
6071h	0	0	8000h to 7FFFh	per thousand of rated torque	Impossible	

Set the torque command used in the cyclic synchronous torque mode (cst) and the profile torque mode (tq).

(2) Max torque (6072h)

Index	Sub	Name		Data Type	Access	PDO Mapping
6072h	0	Max torque		UNSIGNED16	rw	Possible
Index	Sub	Default	Range	Units	EEP-ROM	Parameter
6072h	0		0000h to FFFFh	per thousand of rated torque	Impossible	

The maximum torque of the servo motor is returned. The value notified by this object is the maximum current and feedback value and may not match the maximum torque mentioned in "Servo Motor Instruction Manual (Vol. 3)".

(3) Torque demand value (6074h)

Index	Sub	Name		Data Type	Access	PDO Mapping
6074h	0	Torque demand value		INTEGER16	ro	Possible
Index	Sub	Default	Range	Units	EEP-ROM	Parameter
6074h	0		8000h to 7FFFh	per thousand of rated torque	Impossible	

The torque command is returned.

(4) Torque actual value (6077h)

Index	Sub	Name		Data Type	Access	PDO Mapping
6077h	0	Torque actual value		INTEGER16	ro	Possible
Index	Sub	Default	Range	Units	EEP-ROM	Parameter
6077h	0		8000h to 7FFFh	per thousand of rated torque	Impossible	

The current torque is returned.

18. EtherCAT COMMUNICATION

(5) Torque slope (6087h)

Index	Sub	Name	Data Type	Access	PDO Mapping
6087h	0	Torque slope	UNSIGNED32	rw	Possible

Index	Sub	Default	Range	Units	EEP-ROM	Parameter
6087h	0	00000000h	00000000h to 00989680h (10000000)	per thousand of rated torque per second	Possible	PT53

Set the variation per second of the torque command used in the profile torque mode (tq). When "0" is set, the setting value is invalid and the torque command is input with step input.

(6) Torque profile type (6088h)

Index	Sub	Name	Data Type	Access	PDO Mapping
6088h	0	Torque profile type	INTEGER16	rw	Possible

Index	Sub	Default	Range	Units	EEP-ROM	Parameter
6088h	0	0	0000h to 0000h		Impossible	

Set the torque command pattern. The description is as follows.

Setting value	Description
0	Linear ramp
1	sin ² ramp (Not supported) (Note)

Note. This is not supported by the driver.

Values other than "0" cannot be set.

(7) Positive torque limit value (60E0h)

Index	Sub	Name	Data Type	Access	PDO Mapping
60E0h	0	Positive torque limit value	UNSIGNED16	rw	Possible

Index	Sub	Default	Range	Units	EEP-ROM	Parameter
60E0h	0	10000	0000h to 2710h (10000)	per thousand of rated torque	Possible	PA11 (POL disabled) PA12 (POL enabled)

You can limit the torque or generated by the servo motor. Set the limit value of the torque of the servo motor in the CCW power running or CW regeneration, or the limit value of the linear servo motor in the positive direction power running or negative direction regeneration. Set this object to "0" to generate no torque

18. EtherCAT COMMUNICATION

(8) Negative torque limit value (60E1h)

Index	Sub	Name	Data Type	Access	PDO Mapping
60E1h	0	Negative torque limit value	UNSIGNED16	rw	Possible

Index	Sub	Default	Range	Units	EEP-ROM	Parameter
60E1h	0	10000	0000h to 2710h (10000)	per thousand of rated torque	Possible	PA12 (POL disabled) PA11 (POL enabled)

You can limit the torque or generated by the servo motor. Set the limit value of the torque of the servo motor in the CW power running or CCW regeneration, or the limit value of the linear servo motor in the negative direction power running or positive direction regeneration. Set this object to "0" to generate no torque.

18. 7. 3. 12 Profile Position Mode Objects

(1) Target position (607Ah)

Index	Sub	Name	Data Type	Access	PDO Mapping
607Ah	0	Target position	INTEGER32	rw	Possible

Index	Sub	Default	Range	Units	EEP-ROM	Parameter
607Ah	0	0	Refer to the text.	pos units	Impossible	

Set the position command used in the cyclic synchronous position mode (csp) and the profile position mode (pp). The settable values vary depending on the control mode and the setting of [Pr. PT01].

Control mode	[Pr. PT01] setting	Range
Cyclic synchronous position mode (csp)		80000000h to 7FFFFFFFh (-2147483648 to 2147483647)
Profile position mode (pp)	_ 0 _ _ (mm)	FFF0BDC1h to 000F423Fh (-999999 to 999999)
	_ 1 _ _ (inch)	FFF0BDC1h to 000F423Fh (-999999 to 999999)
	_ 2 _ _ (degree)	FFFA81C0h to 00057E40h (-360000 to 360000)
	_ 3 _ _ (pulse)	FFF0BDC1h to 000F423Fh (-999999 to 999999)

Set also Gear ratio (6091h) for the profile position mode (pp).

(2) Position range limit (607Bh)

Index	Sub	Name	Data Type	Access	PDO Mapping
607Bh	0	Position range limit	UNSIGNED8	ro	Impossible
	1	Min position range limit	INTEGER32	rw	Possible
	2	Max position range limit			

Index	Sub	Default	Range	Units	EEP-ROM	Parameter
607Bh	0	2	00h to 02h		Impossible	
	1		Refer to the text.	pos units		
	2					

No value can be written because Position range limit (607Bh) is set automatically with the control mode and [Pr. PT01]. Writing any value causes SDO Abort Code (0609 0030h Value range of parameter exceeded).

This object is available with drivers.

Control mode	[Pr. PT01] setting	Range
Cyclic synchronous mode		80000000h to 7FFFFFFFh (-2147483648 to 2147483647)
Profile mode	_ 0 _ _ (mm)	80000000h to 7FFFFFFFh (-2147483648 to 2147483647)
	_ 1 _ _ (inch)	80000000h to 7FFFFFFFh (-2147483648 to 2147483647)
	_ 2 _ _ (degree)	00000000h to 00057E3Fh (0 to 359999)
	_ 3 _ _ (pulse)	80000000h to 7FFFFFFFh (-2147483648 to 2147483647)
Point table method	_ 0 _ _ (mm)	80000000h to 7FFFFFFFh (-2147483648 to 2147483647)
	_ 1 _ _ (inch)	80000000h to 7FFFFFFFh (-2147483648 to 2147483647)
	_ 3 _ _ (pulse)	80000000h to 7FFFFFFFh (-2147483648 to 2147483647)
Indexer method		0 to set value in [Pr. PT28] -1

(3) Software position limit (607Dh)

Index	Sub	Name	Data Type	Access	PDO Mapping
607Dh	0	Software position limit	UNSIGNED8	ro	Impossible
	1	Min position limit	INTEGER32	rw	Possible
	2	Max position limit			

Index	Sub	Default	Range	Units	EEP-ROM	Parameter
607Dh	0	2	02h to 02h		Impossible	
	1	0	80000000h to 7FFFFFFFh	pos units	Possible	PT17/PT18
	2					PT15/PT16

Set the range for limiting the command position. Target position (607Ah) is limited within the range between Min position limit (607Dh: 1) and Max position limit (607Dh: 2). When the set value of Min position limit (607Dh: 1) is equal to or greater than the set value of Max position limit (607Dh: 2), the function of Software position limit (607Dh) is disabled. In the indexer method, this function is disabled.

18. EtherCAT COMMUNICATION

(4) Max profile velocity (607Fh)

Index	Sub	Name	Data Type	Access	PDO Mapping
607Fh	0	Max profile velocity	UNSIGNED32	rw	Possible

Index	Sub	Default	Range	Units	EEP-ROM	Parameter
607Fh	0	2000000	00000000h to 001E8480h (2000000)	vel units	Possible	PT66

Set the speed limit value for the profile position mode (pp), profile velocity mode (pv), Jog mode (jg) and indexer mode (idx). When a value exceeding this object is set to Target velocity (60FFh) or Profile velocity (6081h), the speed is limited with the value of this object.

(5) Max motor speed (6080h)

Index	Sub	Name	Data Type	Access	PDO Mapping
6080h	0	Max motor speed	UNSIGNED32	rw	Possible

Index	Sub	Default	Range	Units	EEP-ROM	Parameter
6080h	0		00000000h to FFFFFFFFh	Refer to the text.	Impossible	

The instantaneous permissible speed of the servo motor is returned. Operation cannot be performed at a speed exceeding the speed set with this object.

Unit: [r/min]

(6) Profile velocity (6081h)

Index	Sub	Name	Data Type	Access	PDO Mapping
6081h	0	Profile velocity	UNSIGNED32	rw	Possible

Index	Sub	Default	Range	Units	EEP-ROM	Parameter
6081h	0	10000	00000000h to instantaneous permissible speed	vel units	Possible	PT65

Set the command speed for the profile position mode (pp), Jog mode (jg) and indexer mode (idx). Set a value within the range between "0" and permissible speed.

Unit: [0.01 r/min]

18. EtherCAT COMMUNICATION

(7) Profile acceleration (6083h)

Index	Sub	Name	Data Type	Access	PDO Mapping
6083h	0	Profile acceleration	UNSIGNED32	rw	Possible

Index	Sub	Default	Range	Units	EEP-ROM	Parameter
6083h	0	0	Refer to the text.	ms	Possible	PT49

Set the acceleration time constant for the profile position mode (pp), profile velocity mode (pv), Jog mode (jg) and indexer mode (idx). Set a time for the servo motor to reach the rated speed. The settable values vary depending on the control mode.

Control mode	Range
Profile position mode (pp)	0 to 20000
Profile velocity mode (pv)	0 to 50000
Jog mode (jg)	0 to 20000
Indexer mode (idx)	0 to 20000

(8) Profile deceleration (6084h)

Index	Sub	Name	Data Type	Access	PDO Mapping
6084h	0	Profile deceleration	UNSIGNED32	rw	Possible

Index	Sub	Default	Range	Units	EEP-ROM	Parameter
6084h	0	0	Refer to the text.	ms	Possible	PT50

Set the deceleration time constant for the profile position mode (pp), profile velocity mode (pv), Jog mode (jg) and indexer mode (idx). Set a time for the servo motor to stop from the rated speed. The settable values vary depending on the control mode.

Control mode	Range
Profile position mode (pp)	0 to 20000
Profile velocity mode (pv)	0 to 50000
Jog mode (jg)	0 to 20000
Indexer mode (idx)	0 to 20000

(9) Quick stop deceleration (6085h)

Index	Sub	Name	Data Type	Access	PDO Mapping
6085h	0	Quick stop deceleration	UNSIGNED32	rw	Possible

Index	Sub	Default	Range	Units	EEP-ROM	Parameter
6085h	0	100	0 to 20000	ms	Possible	PC24

Set a deceleration time constant for the Quick stop function. Set a time for the servo motor to stop from the rated speed. When "0" is set, the operation is performed with 100 ms.

18. EtherCAT COMMUNICATION

(10) Motion profile type (6086h)

Index	Sub	Name		Data Type	Access	PDO Mapping
6086h	0	Motion profile type		INTEGER16	rw	Possible
Index	Sub	Default	Range	Units	EEP-ROM	Parameter
6086h	0	-1	FFFFh to FFFFh (-1)		Impossible	

Set the acceleration/deceleration pattern in the profile position mode (pp). The description is as follows.

Setting value	Description
-1	S-pattern
0	Linear ramp (Not supported) (Note)
1	sin ² ramp (Not supported) (Note)
2	Jerk-free ramp (Not supported) (Note)
3	Jerk-limited ramp (Not supported) (Note)

Note. This is not supported by the driver.

For this object, "-1" is always returned. Values other than "-1" cannot be set.

18. 7. 3. 13 Homing Mode Objects

(1) Home offset (607Ch)

Index	Sub	Name		Data Type	Access	PDO Mapping
607Ch	0	Home offset		INTEGER32	rw	Possible
Index	Sub	Default	Range	Units	EEP-ROM	Parameter
607Ch	0	0	80000000h to 7FFFFFFFh	pos units	Possible	

The home position is returned. No value can be written because Home offset (607Ch) is set automatically. Writing any value causes SDO Abort Code (0609 0030h Value range of parameter exceeded).

(2) Homing method (6098h)

Index	Sub	Name		Data Type	Access	PDO Mapping
6098h	0	Homing method		INTEGER8	rw	Possible
Index	Sub	Default	Range	Units	EEP-ROM	Parameter
6098h	0	37	D5h (-43) to 25h (37)		Possible	PT45

Set a home position return type. Refer to section 5.4.9 (4) for the settable values.

18. EtherCAT COMMUNICATION

(3) Homing speeds (6099h)

Index	Sub	Name	Data Type	Access	PDO Mapping
6099h	0	Homing speeds	UNSIGNED8	ro	Impossible
	1	Speed during search for switch	UNSIGNED32	rw	Possible
	2	Speed during search for zero			

Index	Sub	Default	Range	Units	EEP-ROM	Parameter
6099h	0	2	02h to 02h		Impossible	
	1	10000	0 to instantaneous permissible speed	vel units	Possible	PT05
	2	1000				PT06

Set the servo motor speed at home position return.

Set the servo motor speed at home position return for Speed during search for switch (6099h: 1).

Unit: [0.01 r/min]

Set the creep speed after proximity dog at home position return for Speed during search for zero (6099h: 2).

Unit: [0.01 r/min]

(4) Homing acceleration (609Ah)

Index	Sub	Name	Data Type	Access	PDO Mapping
609Ah	0	Homing acceleration	UNSIGNED32	rw	Possible

Index	Sub	Default	Range	Units	EEP-ROM	Parameter
609Ah	0	0	00000000h to 00004E20h (20000)	ms	Possible	PT56

Set the acceleration/deceleration time constants at home position return. Set a time for the servo motor to reach the rated speed.

18. EtherCAT COMMUNICATION

(5) Supported homing method (60E3h)

(a) In the cyclic synchronous mode/profile mode/point table method

Index	Sub	Name	Data Type	Access	PDO Mapping
60E3h	0	Supported homing method	UNSIGNED8	ro	Impossible
	1	1st supported homing method	INTEGER8		
	2	2nd supported homing method			
	3	3rd supported homing method			
	4	4th supported homing method			
	5	5th supported homing method			
	6	6th supported homing method			
	7	7th supported homing method			
	8	8th supported homing method			
	9	9th supported homing method			
	10	10th supported homing method			
	11	11th supported homing method			
	12	12th supported homing method			
	13	13th supported homing method			
	14	14th supported homing method			
	15	15th supported homing method			
	16	16th supported homing method			
	17	17th supported homing method			
	18	18th supported homing method			
	19	19th supported homing method			
	20	20th supported homing method			
	21	21st supported homing method			
	22	22nd supported homing method			
	23	23rd supported homing method			
	24	24th supported homing method			
	25	25th supported homing method			
	26	26th supported homing method			
	27	27th supported homing method			
	28	28th supported homing method			
	29	29th supported homing method			
	30	30th supported homing method			
	31	31st supported homing method			
	32	32nd supported homing method			
	33	33rd supported homing method			
	34	34th supported homing method			
	35	35th supported homing method			
	36	36th supported homing method			
	37	37th supported homing method			
	38	38th supported homing method			
39	39th supported homing method				

18. EtherCAT COMMUNICATION

Index	Sub	Default	Range	Units	EEP-ROM	Parameter
60E3h	0	39	27h (39)		Impossible	
	1	37	25h (37)			
	2	35	23h (35)			
	3	34	22h (34)			
	4	33	21h (33)			
	5	28	1Ch (28)			
	6	27	1Bh (27)			
	7	24	18h (24)			
	8	23	17h (23)			
	9	22	16h (22)			
	10	21	15h (21)			
	11	20	14h (20)			
	12	19	13h (19)			
	13	12	0Ch (12)			
	14	11	0Bh (11)			
	15	8	08h (8)			
	16	7	07h (7)			
	17	6	06h (6)			
	18	5	05h (5)			
	19	4	04h (4)			
	20	3	03h (3)			
	21	-1	FFh (-1)			
	22	-2	FEh (-2)			
	23	-3	FDh (-3)			
	24	-4	FCh (-4)			
	25	-6	FAh (-6)			
	26	-7	F9h (-7)			
	27	-8	F8h (-8)			
	28	-9	F7h (-9)			
	29	-10	F6h (-10)			
	30	-11	F5h (-11)			
	31	-33	DFh (-33)			
	32	-34	DEh (-34)			
	33	-36	DCh (-36)			
	34	-38	DAh (-38)			
	35	-39	D9h (-39)			
	36	-40	D8h (-40)			
	37	-41	D7h (-41)			
	38	-42	D6h (-42)			
39	-43	D5h (-43)				

The supported home position return type is returned.

18. EtherCAT COMMUNICATION

(b) Indexer method

Index	Sub	Name	Data Type	Access	PDO Mapping
60E3h	0	Supported homing method	UNSIGNED8	ro	Impossible
	1	1st supported homing method	INTEGER8		
	2	2nd supported homing method			
	3	3rd supported homing method			
	4	4th supported homing method			
	5	5th supported homing method			
	6	6th supported homing method			
	7	7th supported homing method			
	8	8th supported homing method			
	9	9th supported homing method			
	10	10th supported homing method			
	11	11th supported homing method			
	12	12th supported homing method			
	13	13th supported homing method			
	14	14th supported homing method			
	15	15th supported homing method			
	16	16th supported homing method			
	17	17th supported homing method			
	18	18th supported homing method			
	19	19th supported homing method			
	20	20th supported homing method			
	21	21st supported homing method			
	22	22nd supported homing method			
	23	23rd supported homing method			
	24	24th supported homing method			
	25	25th supported homing method			
	26	26th supported homing method			
	27	27th supported homing method			
	28	28th supported homing method			
	29	29th supported homing method			
	30	30th supported homing method			
	31	31st supported homing method			
	32	32nd supported homing method			
	33	33rd supported homing method			
	34	34th supported homing method			
	35	35th supported homing method			
	36	36th supported homing method			
	37	37th supported homing method			
	38	38th supported homing method			
39	39th supported homing method				

18. EtherCAT COMMUNICATION

Index	Sub	Default	Range	Units	EEP-ROM	Parameter
60E3h	0	39	27h (39)		Impossible	
	1	37	25h (37)			
	2	35	23h (35)			
	3	-1	FFh (-1)			
	4	-3	FDh (-3)			
	5	-33	DFh (-33)			
	6	0	0h (0)			
	7	0	0h (0)			
	8	0	0h (0)			
	9	0	0h (0)			
	10	0	0h (0)			
	11	0	0h (0)			
	12	0	0h (0)			
	13	0	0h (0)			
	14	0	0h (0)			
	15	0	0h (0)			
	16	0	0h (0)			
	17	0	0h (0)			
	18	0	0h (0)			
	19	0	0h (0)			
	20	0	0h (0)			
	21	0	0h (0)			
	22	0	0h (0)			
	23	0	0h (0)			
	24	0	0h (0)			
	25	0	0h (0)			
	26	0	0h (0)			
	27	0	0h (0)			
	28	0	0h (0)			
	29	0	0h (0)			
	30	0	0h (0)			
	31	0	0h (0)			
	32	0	0h (0)			
	33	0	0h (0)			
	34	0	0h (0)			
	35	0	0h (0)			
	36	0	0h (0)			
	37	0	0h (0)			
	38	0	0h (0)			
	39	0	0h (0)			

The supported home position return type is returned.

18. EtherCAT COMMUNICATION

18.7.3.14 Factor Group Objects

(1) Polarity (607Eh)

Index	Sub	Name		Data Type	Access	PDO Mapping
607Eh	0	Polarity		UNSIGNED8	rw	Possible

Index	Sub	Default	Range	Units	EEP-ROM	Parameter
607Eh	0	00h	Refer to the text.		Possible	PA14 PC29

The rotation direction selection can be set.

Bit	Description
0	reserved
1	reserved
2	reserved
3	reserved
4	reserved
5	0: Servo motor CCW rotation at positive torque 1: Servo motor CW rotation at positive torque
6	0: Servo motor CCW rotation at positive speed 1: Servo motor CW rotation at positive speed
7	0: Servo motor CCW rotation in positioning address increasing direction 1: Servo motor CW rotation in positioning address increasing direction

For the driver, only "00h", "C0h", or "E0h" can be set. Values other than 00h and C0h cannot be set.

(2) Position encoder resolution (608Fh)

Index	Sub	Name		Data Type	Access	PDO Mapping
608Fh	0	Position encoder resolution		UNSIGNED8	ro	Impossible
	1	Encoder increments		UNSIGNED32	rw	Possible
	2	Motor revolutions				

Index	Sub	Default	Range	Units	EEP-ROM	Parameter
608Fh	0	2	02h to 02h	inc/rev	Impossible	
	1		00000000h to FFFFFFFFh	inc		
	2	1	00000001h to 00000001h	rev		

Encoder resolution is returned with Encoder increments (608Fh: 1). No value can be written because Position encoder resolution (608Fh) is set automatically. Writing any value causes SDO Abort Code (0609 0030h Value range of parameter exceeded).

18. EtherCAT COMMUNICATION

(3) Gear ratio (6091h)

Index	Sub	Name	Data Type	Access	PDO Mapping
6091h	0	Gear ratio	UNSIGNED8	ro	Impossible
	1	Motor revolutions	UNSIGNED32	rw	Possible
	2	Shaft revolutions			

Index	Sub	Default	Range	Units	EEP-ROM	Parameter
6091h	0	2	02h to 02h		Impossible	
	1	1	00000001h to 00FFFFFFh (16777215)	rev	Possible	PA06
	2					PA07

Set the electronic gear. Refer to [Pr. PA06] for the settable values. In the cyclic synchronous mode , setting Motor revolutions (6091h: 1) or Shaft revolutions (6091h: 2) to anything other than "1" will trigger [AL. 37].

$$\text{Gear ratio (6091h)} = \frac{\text{Motor revolutions (6091h: 1)}}{\text{Shaft revolutions (6091h: 2)}}$$

(4) Feed constant (6092h)

Index	Sub	Name	Data Type	Access	PDO Mapping
6092h	0	Feed constant	UNSIGNED8	ro	Impossible
	1	Feed	INTEGER32	rw	Possible
	2	Shaft revolutions			

Index	Sub	Default	Range	Units	EEP-ROM	Parameter
6092h	0	2	02h to 02h		Impossible	
	1		Refer to the text.	pos units		
	2	1		rev		

No value can be written because Feed (6092h: 1) and Shaft revolutions (6092h: 2) are set automatically with the control mode, [Pr. PT01] and [Pr. PT03]. Writing any value causes SDO Abort Code (0609 0030h Value range of parameter exceeded).

This object is available with drivers.

Control mode	[Pr. PT01] setting	[Pr. PT03] setting	Range	
			Feed	Shaft revolutions
Cyclic synchronous mode		___ 0 to ___ 3	Encoder resolution of the servo motor	1
Profile mode	_ 0 __ (mm) _ 1 __ (inch)	___ 0	Encoder resolution of the servo motor	1
		___ 1		10
		___ 2		100
	___ 3	1000		
	_ 2 __ (degree)		360000	
	_ 3 __ (pulse)	___ 0 to ___ 3	Encoder resolution of the servo motor	1
Point table method (Note)	_ 0 __ (mm) _ 1 __ (inch)	___ 0	Encoder resolution of the servo motor	1
		___ 1		10
		___ 2		100
	___ 3	1000		
	_ 3 __ (pulse)	___ 0 to ___ 3		1
Indexer method (Note)		___ 0 to ___ 3	[Pr. PT28] setting	1

18. EtherCAT COMMUNICATION

Position actual value (6064h) is calculated from Gear ratio (6091h) and Feed constant (6092h), as follows.

$$\text{Position actual value (6064h)} = \frac{\text{Position actual internal value (6063h)} \times \text{Feed constant (6092h)}}{\text{Position encoder resolution (608Fh)} \times \text{Gear ratio (6091h)}}$$

When the unit is degree, the operation result will be limited within 0 to 359999.

(5) SI unit position (60A8h)

Index	Sub	Name	Data Type	Access	PDO Mapping
60A8h	0	SI unit position	UNSIGNED32	rw	Impossible

Index	Sub	Default	Range	Units	EEP-ROM	Parameter
60A8h	0	0	Refer to the text.	pos units	Impossible	

No value can be written because SI unit position (60A8h) is set automatically with the control mode, [Pr. PT01] and [Pr. PT03]. Writing any value causes SDO Abort Code (0609 0030h Value range of parameter exceeded).

This object is available with drivers

Control mode	[Pr. PT01] setting	[Pr. PT03] setting	Range	
Cyclic synchronous mode		___ 0 to ___ 3	00000000h (1 pulse)	
Profile mode	_ 0 _ _ (mm)	___ 0 (x 1)	FA010000h (0.001 mm)	
		___ 1 (x 10)	FB010000h (0.01 mm)	
		___ 2 (x 100)	FC010000h (0.1 mm)	
		___ 3 (x 1000)	FD010000h (1 mm)	
	_ 1 _ _ (inch)	___ 0 (x 1)	FCC00000h (0.0001 inch)	
		___ 1 (x 10)	FDC00000h (0.001 inch)	
		___ 2 (x 100)	FEC00000h (0.01 inch)	
		___ 3 (x 1000)	FFC00000h (0.1 inch)	
	_ 2 _ _ (degree)		___ 0 to ___ 3	FD410000h (0.001 degree)
	_ 3 _ _ (pulse)		___ 0 to ___ 3	00000000h (1 pulse)
	Point table method	_ 0 _ _ (mm)	___ 0 (x 1)	FA010000h (0.001 mm)
			___ 1 (x 10)	FB010000h (0.01 mm)
___ 2 (x 100)			FC010000h (0.1 mm)	
___ 3 (x 1000)			FD010000h (1 mm)	
_ 1 _ _ (inch)		___ 0 (x 1)	FCC00000h (0.0001 inch)	
		___ 1 (x 10)	FDC00000h (0.001 inch)	
		___ 2 (x 100)	FEC00000h (0.01 inch)	
		___ 3 (x 1000)	FFC00000h (0.1 inch)	
_ 3 _ _ (pulse)			___ 0 to ___ 3	00000000h (1 pulse)
Indexer method			___ 0 to ___ 3	00000000h (no unit)

18. EtherCAT COMMUNICATION

(6) SI unit velocity (60A9h)

Index	Sub	Name	Data Type	Access	PDO Mapping
60A9h	0	SI unit velocity	UNSIGNED32	rw	Impossible

Index	Sub	Default	Range	Units	EEP-ROM	Parameter
60A9h	0	0	FB010300h (0.01 mm/s) FEB44700h (0.01 r/min)	vel units	Impossible	

The SI unit velocity is returned. No value can be written because SI unit velocity (60A9h) is set automatically with the control mode. Writing any value causes SDO Abort Code (0609 0030h Value range of parameter exceeded).

This object is available with drivers.

18. 7. 3. 15 Touch Probe Function Objects

(1) Touch probe function (60B8h)

Index	Sub	Name	Data Type	Access	PDO Mapping
60B8h	0	Touch probe function	UNSIGNED16	rw	Possible

Index	Sub	Default	Range	Units	EEP-ROM	Parameter
60B8h	0	0	0000h to FFFFh		Impossible	

Set the command for the touch probe function. Refer to section 5.5 (1) (a) for details.

(2) Touch probe status (60B9h)

Index	Sub	Name	Data Type	Access	PDO Mapping
60B9h	0	Touch probe status	UNSIGNED16	ro	Possible

Index	Sub	Default	Range	Units	EEP-ROM	Parameter
60B9h	0		0000h to FFFFh		Impossible	

The status of the touch probe function is returned. Refer to section 5.5 (1) (b) for details.

(3) Touch probe pos1 pos value (60BAh)

Index	Sub	Name	Data Type	Access	PDO Mapping
60BAh	0	Touch probe pos1 pos value	INTEGER32	ro	Possible

Index	Sub	Default	Range	Units	EEP-ROM	Parameter
60BAh	0	0	80000000h to 7FFFFFFFh	pos units	Impossible	

The position latched at the rising edge of touch probe 1 is returned.

(4) Touch probe pos1 neg value (60BBh)

Index	Sub	Name	Data Type	Access	PDO Mapping
60BBh	0	Touch probe pos1 neg value	INTEGER32	ro	Possible

Index	Sub	Default	Range	Units	EEP-ROM	Parameter
60BBh	0	0	80000000h to 7FFFFFFFh	pos units	Impossible	

The position latched at the falling edge of touch probe 1 is returned.

18. EtherCAT COMMUNICATION

(5) Touch probe pos2 pos value (60BCh)

Index	Sub	Name		Data Type	Access	PDO Mapping
60BCh	0	Touch probe pos2 pos value		INTEGER32	ro	Possible
Index	Sub	Default	Range	Units	EEP-ROM	Parameter
60BCh	0	0	80000000h to 7FFFFFFFh	pos units	Impossible	

The position latched at the rising edge of touch probe 2 is returned.

(6) Touch probe pos2 neg value (60BDh)

Index	Sub	Name		Data Type	Access	PDO Mapping
60BDh	0	Touch probe pos2 neg value		INTEGER32	ro	Possible
Index	Sub	Default	Range	Units	EEP-ROM	Parameter
60BDh	0	0	80000000h to 7FFFFFFFh	pos units	Impossible	

The position latched at the falling edge of touch probe 2 is returned.

18. 7. 3. 16 Optional application FE Objects

(1) Digital inputs (60FDh)

Index	Sub	Name		Data Type	Access	PDO Mapping
60FDh	0	Digital inputs		UNSIGNED32	ro	Possible
Index	Sub	Default	Range	Units	EEP-ROM	Parameter
60FDh	0		00000000h to 037E0007h		Impossible	

The on/off states of the input device connected to the driver are returned.

This object is available with drivers.

18. EtherCAT COMMUNICATION

Bit	Reading connector pin No.	Initial device	Input device changing parameter (Note 2)	Status reading selection parameter (Note 3)	LSP/LSN output reversing parameter (Note 4)	Description
0					PC76	Negative limit switch [Pr. PA14] = 0 0: LSN (Reverse rotation stroke end) off 1: LSN (Reverse rotation stroke end) on [Pr. PA14] = 1 0: LSP (Forward rotation stroke end) off 1: LSP (Forward rotation stroke end) on
1					PC76	Positive limit switch [Pr. PA14] = 0 0: LSP (Forward rotation stroke end) off 1: LSP (Forward rotation stroke end) on [Pr. PA14] = 1 0: LSN (Reverse rotation stroke end) off 1: LSN (Reverse rotation stroke end) on
2						home switch 0: DOG (Proximity dog) off 1: DOG (Proximity dog) on
3 to 16						(reserved) The value at reading is undefined.
17	CN3-2	LSP	PD03	PC79	PC76 (Note 5)	DI1 0: Off 1: On
18	CN3-12	LSN	PD04	PC79	PC76 (Note 5)	DI2 0: Off 1: On
19	CN3-19	DOG	PD05	PC79	PC76 (Note 5)	DI3 0: Off 1: On
20	CN3-10	TPR1		PC79		DI4 0: TPR1 (Touch probe 1) off 1: TPR1 (Touch probe 1) on
21	CN3-1	TPR2		PC79		DI5 0: TPR2 (Touch probe 2) off 1: TPR2 (Touch probe 2) on
22	CN3-20	EM2	PA04	PC79		EM2/EM1 0: Off 1: On
23						(reserved) The value at reading is undefined.
24	CN8-4					Safe torque off 1 0: STO1 off 1: STO1 on
25	CN8-5					Safe torque off 2 0: STO2 off 1: STO2 on
26 to 31						(reserved) The value at reading is undefined.

2. You can change input devices of the pin with this parameter setting. When [Pr. PD03] to [Pr. PD05] are set to "_ _ 0 0", the ON/OFF state of each pin is returned.
3. With this parameter setting, you can specify whether the ON/OFF states of the input devices are returned or the ON/OFF states of the pins are returned.
4. You can reverse the output with this parameter setting.
5. This parameter is available when [Pr. PC79] is set to "0" (the ON/OFF states of the input devices are returned) while LSP or LSN is assigned to each pin.

(2) Digital outputs (60FEh)

Index	Sub	Name	Data Type	Access	PDO Mapping
60FEh	0	Number of entries	UNSIGNED8	ro	Impossible
	1	Physical outputs	UNSIGNED32	rw	Possible
	2	Bit mask			

Index	Sub	Default	Range	Units	EEP-ROM	Parameter
60FEh	0	2	02h to 02h	/	Impossible	/
	1	0	00000000h to 000E0000h			
	2	0				

Set the ON/OFF states of the output devices connected to the driver.
 This object is available with drivers.

(a) Physical outputs (60FEh: 1)

Bit	Description
0 to 16	(reserved) The value at reading is undefined. Set "0" when writing.
17	DO1 0: DOA (General-purpose output A) off 1: DOA (General-purpose output A) on When using this bit, assign DOA (General-purpose output A) to CN3-9, CN3-13 or CN3-15 pin in [Pr. PD07] to [Pr. PD09].
18	DO2 0: DOB (General-purpose output B) off 1: DOB (General-purpose output B) on When using this bit, assign DOB (General-purpose output B) to CN3-9, CN3-13 or CN3-15 pin in [Pr. PD07] to [Pr. PD09].
19	DO3 0: DOC (General-purpose output C) off 1: DOC (General-purpose output C) on When using this bit, assign DOC (General-purpose output C) to CN3-9, CN3-13 or CN3-15 pin in [Pr. PD07] to [Pr. PD09].
20 to 31	(reserved) The value at reading is undefined. Set "0" when writing.

(b) Bit mask (60FEh: 2)

Bit	Description
0 to 16	(reserved) The value at reading is undefined. Set "0" when writing.
17	DO1 0: DOA (General-purpose output A) disabled 1: DOA (General-purpose output A) enabled When this bit is set to "0", bit 17 of the Physical outputs is always "0".
18	DO2 0: DOB (General-purpose output B) disabled 1: DOB (General-purpose output B) enabled When this bit is set to "0", bit 18 of the Physical outputs is always "0".
19	DO3 0: DOC (General-purpose output C) disabled 1: DOC (General-purpose output C) enabled When this bit is set to "0", bit 19 of the Physical outputs is always "0".
20 to 31	(reserved) The value at reading is undefined. Set "0" when writing.

18. EtherCAT COMMUNICATION

18.7.3.17 Point Table Mode Objects

(1) Target point table (2D60h)

Index	Sub	Name	Data Type	Access	PDO Mapping
2D60h	0	Target point table	INTEGER16	rw	Possible

Index	Sub	Default	Range	Units	EEP-ROM	Parameter
2D60h	0	0	Refer to the text.		Impossible	

In the point table mode (pt), specify the point table No. to execute. In the indexer mode (idx), set the next station No to execute. The settable values vary depending on the control mode.

This object is available with drivers.

Control mode	Range
Point table mode (pt)	FFFFh to 00FFh (-1 to 255)
Indexer mode (idx)	0000h to 00FEh (0 to 254)

(2) Point demand value (2D68h)

Index	Sub	Name	Data Type	Access	PDO Mapping
2D68h	0	Point demand value	INTEGER16	ro	Possible

Index	Sub	Default	Range	Units	EEP-ROM	Parameter
2D68h	0	0	Refer to the text.		Impossible	

In the point table mode (pt), the currently specified point table No. is returned. In the indexer mode (idx), the currently specified next station No. is returned. The returned values vary depending on the control mode.

This object is available with drivers.

Control mode	Range
Point table mode (pt)	FFFFh to 00FFh (-1 to 255)
Indexer mode (idx)	0000h to 00FEh (0 to 254)

(3) Point actual value (2D69h)

Index	Sub	Name	Data Type	Access	PDO Mapping
2D69h	0	Point actual value	INTEGER16	ro	Possible

Index	Sub	Default	Range	Units	EEP-ROM	Parameter
2D69h	0	0	Refer to the text.		Impossible	

In the point table mode (pt), the completed point table No. is returned. In the indexer mode (idx), the completed station No. is returned. The returned values vary depending on the control mode.

This object is available with drivers.

Control mode	Range
Point table mode (pt)	FFFFh to 00FFh (-1 to 255)
Indexer mode (idx)	0000h to 00FEh (0 to 254)

18. EtherCAT COMMUNICATION

(4) Point table 001 (2801h) to Point table 255 (28FFh)

Index	Sub	Name	Data Type	Access	PDO Mapping
2801h to 28FFh	0	Point table 001 to Point table 255	UNSIGNED8	ro	Impossible
	1	Point data	INTEGER32	rw	
	2	Speed			
	3	Acceleration			
	4	Deceleration			
	5	Dwell			
	6	Auxiliary			
7	M code				

Index	Sub	Default	Range	Units	EEP-ROM	Parameter
2801h to 28FFh	0	7	07h to 07h		Possible	
	1	0	Refer to the text.	pos units		
	2	0	00000000h to instantaneous permissible speed	vel units		
	3	0	00000000h to 00004E20h (0 to 20000)	ms		
	4	0	00000000h to 00004E20h (0 to 20000)	ms		
	5	0	00000000h to 00004E20h (0 to 20000)	ms		
	6	0	00000000h to 00000003h, 00000008h to 0000000Bh (0 to 3, 8 to 11)			
7	0	00000000h to 00000063h (0 to 99)				

Register the positioning data to the point table.

This object is available with drivers.

The settable values in Point data vary depending on the setting of [Pr. PT01].

Setting of [Pr. PT01 (_ x _)]	Range
0 (mm)	FFF0BDC1h to 000F423Fh (-999999 to 999999)
1 (inch)	FFF0BDC1h to 000F423Fh (-999999 to 999999)
3 (pulse)	FFF0BDC1h to 000F423Fh (-999999 to 999999)

When "1" or "3" is set in Auxiliary of the point table No. 255, bit 6 in the Point table error factor (2A43h) turns on and an error occurs. The following shows the description of the values to be set in Auxiliary.

Setting value	Point table command method	Description
0	Absolute value command method	Automatic operation for a selected point table is performed.
1		Automatic continuous operation is performed to the next point table without a stop.
8		Automatic continuous operation is performed without a stop to the point table selected at start-up.
9		Automatic continuous operation is performed without stopping a point table No. 1.
2	Incremental value command method	Automatic operation for a selected point table is performed.
3		Automatic continuous operation is performed to the next point table without a stop.
10		Automatic continuous operation is performed to the point table selected at the start.
11		Automatic continuous operation is performed without stopping a point table No. 1.

18. EtherCAT COMMUNICATION

(5) Point table error (2A43h)

Index	Sub	Name	Data Type	Access	PDO Mapping
2A43h	0	Point table error	UNSIGNED8	ro	Impossible
	1	Point table error No.	UNSIGNED32		
	2	Point table error factor			

Index	Sub	Default	Range	Units	EEP-ROM	Parameter
2A43h	0	2	02h to 02h		Impossible	
	1	0	00000000h to 000000FFh (0 to 255)			
	2	0	00000000h to 000000FDh			

The point table No. in which a point table error has occurred is returned with Point table error No. (2A43h: 1). The error factor of the corresponding point table in which a point table error has occurred is returned with Point table error factor (2A43h: 2).

This object is available with drivers.

Bit	Description
0	0: No error 1: Target position error
1	reserved
2	0: No error 1: Speed error
3	0: No error 1: Acceleration time constant error
4	0: No error 1: Deceleration time constant error
5	0: No error 1: Dwell time error
6	0: No error 1: Auxiliary function error
7	0: No error 1: M code error
8 to 31	reserved

(6) M code actual value (2D6Ah)

Index	Sub	Name	Data Type	Access	PDO Mapping
2D6Ah	0	M code actual value	UNSIGNED8	ro	Possible

Index	Sub	Default	Range	Units	EEP-ROM	Parameter
2D6Ah	0	0	00h to 63h (0 to 99)		Impossible	

The completed M code of the point table is returned. In the indexer method, "0" is returned.

This object is available with drivers.

18. EtherCAT COMMUNICATION

18. 7. 3. 18 Cyclic synchronous position mode Objects

(1) Torque offset (60B2h)

Index	Sub	Name	Data Type	Access	PDO Mapping
60B2h	0	Torque offset	INTEGER16	rw	Possible

Index	Sub	Default	Range	Units	EEP-ROM	Parameter
60B2h	0	0	8000h to 7FFFh	per thousand of rated torque	Impossible	

Set the torque offset used in the cyclic synchronous position mode (csp), the cyclic synchronous velocity mode (csv) and the cyclic synchronous torque mode (cst). If this object is set with other than the cyclic synchronous mode (csp/csv/cst), the set value will be disabled.

This object is available with drivers.

19. EtherNet/IP COMMUNICATION

19 EtherNet/IP COMMUNICATION	3
19.1 EtherNet/IP COMMUNICATION	3
19.1.1 Summary	3
19.1.2 Function list	4
19.1.3 Communication specifications	6
19.1.4 Establishing and disconnecting the communication	7
19.1.4.1 Communication status	7
19.1.4.2 Startup	8
19.1.4.3 Network disconnection procedure	9
19.1.5 Summary of object library	9
19.1.5.1 Section definition of Drive Configuration Object (64h)	9
19.2 EtherNet/IP NETWORK CARD (LEC-S-N9)	10
19.2.1 Specifications	10
19.2.2 Parts identification	10
19.2.3 LED indication	11
19.2.3.1 LED indication definition	11
19.2.3.2 LED indication list	11
19.2.4 Connecting Ethernet cables	12
19.3 I/O COMMUNICATION	13
19.3.1 I/O communication cycle	13
19.3.2 I/O communication mapping	15
19.4 Explicit Message COMMUNICATION	17
19.4.1 Explicit Message communication-related service	17
19.4.2 Common service	18
19.4.2.1 Set_Attribute_Single	18
19.4.2.2 Get_Attribute_Single	18
19.4.2.3 Get_Attributes_All	18
19.4.2.4 Reset	19
19.5 DRIVE PROFILE	19
19.5.1 FSA state	19
19.5.2 Controlword/Control DI	22
19.5.2.1 Bit definition of Controlword	22
19.5.2.2 Bit definition of Control DI	23
19.5.3 Statusword/Status DO	26
19.5.3.1 Bit definition of Statusword	26
19.5.3.2 Bit definition of Status DO	27
19.5.4 Control mode	33
19.5.4.1 Selecting control mode (Modes of operation)	33
19.5.4.2 Control switching	33
19.5.4.3 Profile position mode (pp)	34
19.5.4.4 Profile velocity mode (pv)	38
19.5.4.5 Profile torque mode (tq)	42
19.5.4.6 Homing mode (hm)	45
19.5.5 Touch probe	72
19.5.6 Quick stop	76
19.5.7 Halt	77
19.5.8 Software position limit	78
19.5.9 Torque limit	78
19.5.10 Polarity	79
19.5.11 Degree function	81
19.6 MANUFACTURER FUNCTIONS	83
19.6.1 Object for status monitor	83
19.6.2 Instruction code	85
19.6.2.1 Summary	85

19. EtherNet/IP COMMUNICATION

19.6.2.2	Reading instruction codes.....	85
19.6.2.3	Writing instruction code	86
19.6.2.4	Variable mapping.....	88
19.6.2.5	Respond code	89
19.6.3	Stroke end	90
19.6.4	Definition of alarm-related objects	91
19.6.5	Parameter object.....	92
19.6.5.1	Definition of parameter objects	92
19.6.5.2	Enabling parameters	93
19.6.6	One-touch tuning.....	94
19.6.7	Machine diagnosis function	96
19.6.8	Driver life diagnosis function.....	97
19.6.9	Positioning function by operation start-up signal	97
19.6.9.1	Summary	97
19.6.9.2	Specification list	97
19.6.9.3	Settings.....	97
19.6.9.4	Status obtainable in the network communication	98
19.6.9.5	Operation method	99
19.7	OBJECT LIBRARY.....	102
19.7.1	Store Parameters.....	102
19.7.2	Supported object library list	103
19.7.3	Object library	107
19.7.3.1	General Objects.....	108
19.7.3.2	Communication Setting Objects.....	112
19.7.3.3	Assembly Objects	123
19.7.3.4	Parameter Objects (Class ID: 64h)	125
19.7.3.5	Alarm Objects (Class ID: 64h).....	128
19.7.3.6	Monitor Objects (Class ID: 64h).....	132
19.7.3.7	Manufacturer Specific Control Objects (Class ID: 64h)	143
19.7.3.8	PDS Control Objects (Class ID: 64h)	155
19.7.3.9	Position Control Function Objects (Class ID: 64h)	159
19.7.3.10	Profile Velocity Mode Objects (Class ID: 64h).....	162
19.7.3.11	Profile Torque Mode Objects (Class ID: 64h)	164
19.7.3.12	Profile Position Mode Objects (Class ID: 64h).....	166
19.7.3.13	Homing Mode Objects (Class ID: 64h)	171
19.7.3.14	Factor Group Objects	175
19.7.3.15	Touch Probe Function Objects (Class ID: 64h)	178
19.7.3.16	Optional application FE Objects (Class ID: 64h)	180

19. EtherNet/IP COMMUNICATION

19 EtherNet/IP COMMUNICATION

19.1 EtherNet/IP COMMUNICATION

19.1.1 Summary

EtherNet/IP is the abbreviation of Ethernet Industrial Protocol. It is an industrial open network in which the TCP/IP protocol has been adopted and the CIP (Common Industrial Protocol) has been used in the application layer as the communication protocol. EtherNet/IP is controlled by ODVA (Open DeviceNet Vendor Association, Inc.).

The EtherNet/IP communication is available when the EtherNet/IP network card (LEC-S-N9) is connected to the driver. The driver to which the EtherNet/IP network card is connected is a Generic device type.

Please download the configuration file (EDS file) from SMC website.

(1) Various control modes supported

The driver supports the following control modes.

Control mode	Symbol	Description
Profile position mode	pp	This is a positioning control mode where an end position command is received to drive the servo motor in the commutation with a upper side. Use an absolute position address or relative position address for a command.
Profile velocity mode	pv	This is a control mode where a target speed command is received to drive the servo motor in the communication with a upper side.
Profile torque mode	tq	This is a control mode where a target torque command is received to drive the servo motor in the communication with a upper side.
Homing mode	hm	This is a control mode where the driver performs a home position return using the method directed by the upper side.

(2) Compliance with standards

drivers comply with the following standards. Refer to the following standards for the description not written in this Manual.

Standards	Version
THE CIP NETWORKS LIBRARY Volume 1 Common Industrial Protocol (CIP™)	Edition 3.15
THE CIP NETWORKS LIBRARY Volume 2 EtherNet/IP Adaptation of CIP	Edition 1.16
CANopen Device Profile Drives and Motion Control	Version 2.0

19. EtherNet/IP COMMUNICATION

19.1.2 Function list

The following table lists the functions available with the driver to which the EtherNet/IP network card is connected.

Function	Description	Reference
Profile position mode (pp)	The positioning operation performed by an asynchronous end position command through network is supported.	Section 5.4
Profile velocity mode (pv)	The speed control operation performed by an asynchronous speed command through network is supported.	
Profile torque mode (tq)	The torque control operation performed by an asynchronous torque command through network is supported.	
Homing mode (hm)	The home position return operation specified in each network is supported.	
Model adaptive control	This function achieves a high response and stable control following the ideal model. The two-degrees-of-freedom model adaptive control enables you to set a response to the command and a response to the disturbance separately. Additionally, this function can be disabled. To disable this function, refer to section 7.5	
High-resolution encoder	High-resolution encoder of 4194304 pulses/rev is used for the encoder of the rotary servo motor compatible with the MELSERVO-J4 series.	
Absolute position detection system	Setting a home position once makes home position return unnecessary at every power-on.	– Chapter 12
Gain switching function	You can switch gains during rotation/stop, and can use input devices to switch gains during operation.	– Section 7.2
Advanced vibration suppression control II	This function suppresses vibration at an arm end or residual vibration.	– Section 7.1.5
Machine resonance suppression filter	This filter function (notch filter) decreases the gain of the specific frequency to suppress the resonance of the mechanical system.	– Section 7.1.1
Shaft resonance suppression filter	When a load is mounted to the servo motor shaft, resonance by shaft torsion during driving may generate a mechanical vibration of high frequency. The shaft resonance suppression filter suppresses the vibration.	– Section 7.1.3
Adaptive filter II	The driver detects mechanical resonance and sets filter characteristics automatically to suppress mechanical vibration.	– Section 7.1.2
Low-pass filter	Suppresses high-frequency resonance which occurs as the servo system response is increased.	– Section 7.1.4
Machine analyzer function	This function analyzes the frequency characteristic of the mechanical system by simply connecting an Setup software (MR Configurator2™)-installed personal computer and the driver. Setup software (MR Configurator2™) is necessary for this function.	
Robust filter	For roll feed axis, etc. of which a response level cannot be increased because of the large load to motor inertia ratio, this function improves a disturbance response.	[Pr. PE41]
Slight vibration suppression control	This function suppresses vibration of ±1 pulse generated at a servo motor stop.	[Pr. PB24]
Electronic gear	Positioning control is performed with the value obtained by multiplying the position command from the upper side by a set electronic gear ratio.	[Pr. PA06] [Pr. PA07]
S-pattern acceleration/deceleration time constant	Speed can be increased and decreased smoothly.	[Pr. PT51]
Auto tuning	Automatically adjusts the gain to optimum value if load applied to the servo motor shaft varies.	– Section 6.3
Power regeneration converter	Use the power regeneration converter when the regenerative option cannot provide sufficient regenerative capacity.	– Section 11.4
Regenerative option	Use a regenerative option when the built-in regenerative resistor of the driver does not have sufficient regenerative capacity for a large regenerative power generated.	– Section 11.2
Alarm history clear	This function clears alarm histories.	[Pr. PC21]

19. EtherNet/IP COMMUNICATION

Function	Description	Reference
Torque limit	Limits the servo motor torque.	[Pr. PA11] [Pr. PA12]
Speed limit	The servo motor speed can be limited.	[Pr. PT67]
Status display	Shows servo status on the 3-digit, 7-segment LED display	– Section 4.3
Input signal selection (device settings)	The input devices including LSP (forward rotation stroke end) and LSN (reverse rotation stroke end) can be assigned to certain pins of the CN3 connector.	[Pr. PD03] to [Pr. PD05]
Output signal selection (device settings)	The output devices including ALM (Malfunction) can be assigned to specified pins of the CN3 connector.	[Pr. PD07] to [Pr. PD09]
Output signal (DO) forced output	Turns on/off the output signals forcibly independently of the servo status. Use this function for checking output signal wiring, etc.	– Section 4.5.1 (1) (d)
Test operation mode	Jog operation, positioning operation, motor-less operation, DO forced output, and program operation Setup software (MR Configurator2™) is necessary for this function.	– Section 4.5
Analog monitor output	This function outputs servo status with voltage in real time.	[Pr. PC09] [Pr. PC10]
Setup software (MR Configurator2™)	Using a personal computer, you can perform the parameter setting, test operation, monitoring, and others.	– Section 11.7
Latch function (Touch probe)	This function latches the current position at the rising edge of the external latch input signal.	Section 5.5 – Section 3.5 [Pr. PD37]
One-touch tuning	Gain adjustment is performed just by one click a certain button on Setup software (MR Configurator2™). Also, one-touch tuning can be performed via a network.	Section 6.7 – Section 6.2
SEMI-F47 function	This function enables to avoid triggering [AL. 10 Undervoltage] using the electrical energy charged in the capacitor in case that an instantaneous power failure occurs during operation. Use a 3-phase for the input power supply of the driver. Using a 1-phase 100 V AC/200 V AC for the input power supply will not comply with SEMI-F47 standard.	– Section 7.4 [Pr. PA20] [Pr. PF25]
Tough drive function	This function makes the equipment continue operating even under the condition that an alarm occurs. The tough drive function includes two types: the vibration tough drive and the instantaneous power failure tough drive. However, the drive recorder is not available when: 1. The graph function of Setup software (MR Configurator2™) is being used. 2. The machine analyzer function is being used. 3. [Pr. PF21] is set to "-1". 4. The upper side is not connected (except the test operation mode). 5. An alarm related to the upper side is occurring.	– Section 7.3
Drive recorder function	This function continuously monitors the servo status and records the status transition before and after an alarm for a fixed period of time. You can check the recorded data on the drive recorder window on Setup software (MR Configurator2™) by clicking the "Graph" button.	[Pr. PA23]
STO function	This driver complies with the STO function as functional safety of IEC/EN 61800-5-2. You can create a safety system for the equipment easily.	– Chapter 13
Driver life diagnosis function	You can check the cumulative energization time and the number of on/off times of the inrush relay. This function gives an indication of the replacement time for parts of the driver including a capacitor and a relay before they malfunction. This function is available with Setup software (MR Configurator2™) or via a network.	Section 6.9
Power monitoring function	This function calculates the power running energy and the regenerative power from the data in the driver such as speed and current. Power consumption and others are displayed on Setup software (MR Configurator2™). Also, the power monitoring function can be used via a network.	Section 6.1

19. EtherNet/IP COMMUNICATION

Function	Description	Reference
Machine diagnosis function	From the data in the driver, this function estimates the friction and vibrational component of the drive system in the equipment and recognizes an error in the machine parts, including a ball screw and bearing. This function is available with Setup software (MR Configurator2™) or via a network.	Section 6.8
Lost motion compensation function	This function improves the response delay generated when the machine moving direction is reversed.	– Section 7.6
Super trace control	This function sets constant and uniform acceleration/deceleration droop pulses to almost 0.	– Section 7.7
Limit switch	Limits travel intervals using LSP (Forward rotation stroke end) and LSN (Reverse rotation stroke end).	
Software limit	Limits travel intervals by address using parameters. The same function with the limit switch is enabled by setting parameters.	Section 5.8 – Section 5.3 [Pr. PT15] to [Pr. PT18]
Web server	You can configure various settings and monitor the driver in a web browser. Refer to the website of Mitsubishi Electric Automation, Inc. for details.	
Superimposed synchronous control function	This function drives the servo motor by using externally input pulses as the master.	Section 6.10
Positioning function by operation start-up signal	This function starts positioning with an input signal.	Section 6.11

19. 1. 3 Communication specifications

The following table shows the communication specifications.

Item	Description	Remark
EtherNet/IP communication specifications	THE CIP NETWORKS LIBRARY Volume 1 Common Industrial Protocol (CIP™) THE CIP NETWORKS LIBRARY Volume 2 EtherNet/IP Adaptation of CIP	
Physical layer	10BASE-T/100BASE-TX	
Communication connector	RJ45, 2 ports (port 1 and port 2)	
Communication cable	CAT5e, shielded twisted pair (4 pair) straight cable	Double-shielded type recommended
Network topology	Line, Star, Ring, or a connection topology where the topologies are used together	
Variable communication speed	10 Mbps/100 Mbps (half duplex/full duplex)	
Transmission speed between stations	Max. 100 m	
Number of nodes	Compliant with the specifications of the standard Ethernet	
Explicit message communication	Asynchronous Sending/Receiving: 1 channel each	
I/O message communication	Cycle time: Select from 1 ms to 100 ms	
LED display	Network Status, Card Status, LINK/Activity (port1, port2)	

19. EtherNet/IP COMMUNICATION

19.1.4 Establishing and disconnecting the communication

19.1.4.1 Communication status

The following shows the classification of the communication status. Two communication types are provided: One is the I/O communication where command data and feedback data are sent and received at a constant period. Another is the Explicit Message communication where object data is sent and received asynchronously. Refer to chapter 3 for details of the I/O communication. Refer to chapter 4 for details of the Explicit Message communication.

Establishing the I/O connection and switching the mode to the Run mode make the driver ready for driving the servo motor.

The communication status can be checked with Class 01h, Instance 1h, and Attribute 5 Status. Refer to chapter 7 for details.

Fig. 1.1

Table 1.1 EtherNet/IP state transition

Transition No.	Description
(1)	Power on
(2)	When Connection Manager Object receives a Forward_Open request or a Large_Forward_Open request, the state shifts to the Configuring state.
(3)	When Connection Manager Object fails to establish a connection requested by Forward_Open or Large_Forward_Open, the state shifts to the Non-Existent state.
(4)	When a connection requested by Forward_Open or Large_Forward_Open is established, the state shifts to the Established state. Just after the connection is established, the connection goes in the Idle state. In this state, the servo motor cannot be driven through the communication.
(5)	When the slave receives a Run notification from the master, the state of the slave shifts from the Idle state to the Run state. In this state, the servo motor can be driven through the communication.
(6)	When the slave receives an Idle notification from the master, the state of the slave shifts from the Run state to the Idle state. When the state shifts from the Run state to the Idle state, a hot start is given to the driver.
(7)	When the slave receives a Forward_Close request from the master, the state of the slave shifts to the Closing state.
(8)	When a connection is disconnected by a Forward_Close request, the state shifts to the Non-Existent state. When a communication is disconnected while the connection is in the Run state, a hot start is given to the driver.
(9)	When a disconnection requested by Forward_Close fails, the state shifts from the Closing state to the Establish state.
(10)	When a connection timeout occurs, the state shifts to the Non-Existent state. When a connection timeout occurs while the connection is in the Run state, a hot start is given to the driver.

19. EtherNet/IP COMMUNICATION

19.1.4.2 Startup

The following describes the settings and startup of the EtherNet/IP communication. Refer to section 4.1 for the startup procedure other than the network setting.

(1) Connection with the upper side

Set up the upper side following the manual of the upper side used.

(2) Parameter setting

Set the control mode with [Pr. PA01 Operation mode]. Refer to section 5.2.1 of for the parameter setting.

(3) IP address setting

Set an IP address using the AnybusIPconfig tool offered by HMS Industrial Networks and the axis selection rotary switch (SW2/SW3) on the display of the driver. Change the IP address with the axis selection rotary switch (SW2/SW3) before powering on the driver. The IP address you set can be checked with the "AnybusIPconfig" tool or system configuration window of MR Configurator 2. You can set an IP address as follows.

Axis selection rotary switch (SW2/SW3)	IP address setting value
00h	An IP address set by the AnybusIPconfig tool is used.
01h to FEh	Although an IP address set by the AnybusIPconfig tool is used, the forth octet value is replaced with a value set with the axis selection rotary switch (SW2/SW3). The DHCP function is disabled. Set a hexadecimal value with the axis selection rotary switch (SW2/SW3). The hexadecimal value is converted into a decimal value and set as the fourth octet of the IP address.
FFh	The DHCP function is enabled.

(4) Setting tool

The following table lists the tools used for starting up the EtherNet/IP communication and tool manufacturers.

Tool	Explanation	Manufacturer
MR Configurator 2	This software is used to configure various settings of the driver and helps maintenance works.	
AnybusIPconfig	This tool is used to set an IP address to the EtherNet/IP network card (LEC-S-N9).	Please download the IPConfigTool from SMC website.

19. EtherNet/IP COMMUNICATION

19.1.4.3 Network disconnection procedure

To disconnect the network by stopping device operation or other means, follow the procedure shown below.

- (1) Stop the servo motor.
- (2) Set the shutdown command for Controlword (Class 64h, Instance 6040h, Attribute 0) to establish the servo-off status.
- (3) Issue the Forward_Close service from the upper side and disconnect the I/O communication.
- (4) Shut off the power of the driver and upper side.

19.1.5 Summary of object library

POINT	
	Refer to chapter 7 for details of the object library.

Each data set that EtherNet/IP devices have such as control parameters, command values, and feedback values is handled as an object composed of a Class ID, object name, data type, access rule, and other elements. The object data can be exchanged between the master and slave devices. The aggregate of these objects is called object library.

The drivers support the following objects. Refer to the Reference column for the section where the details of each object are described.

Class ID	Object name	Reference
01h	Identity Object	Section 7.3.1 (1)
02h	Message Router Object	Section 7.3.2 (1)
04h	Assembly Object	Section 7.3.3
06h	Connection Manager Object	Section 7.3.2 (2)
47h	Device Level Ring(DLR) Object	Section 7.3.2 (3)
48h	QoS Object	Section 7.3.2 (4)
F5h	TCP/IP Interface Object	Section 7.3.2 (5)
F6h	Ethernet Link Object	Section 7.3.2 (6)
64h	Drive Configuration Object	Section 7.3.1 (2) Section 7.3.4 to 7.3.16

19.1.5.1 Section definition of Drive Configuration Object (64h)

The master can control the slave by sending and receiving commands/feedback data via Drive Configuration Object. Instances of Drive Configuration Object are categorized as follows according to the CiA 402 standard.

Class ID	Ins ID	Description	Reference
64h	1000h to 1FFFh	CoE communication area	Chapter 7
	2000h to 25FFh	Parameter area (Vendor-specific)	Section 6.5, Chapter 7
	2A00h to 2FFFh	Servo control command/monitor area (Vendor-specific)	Chapter 6, Chapter 7
	6000h to 6FFFh	CiA 402 Drive profile area	Chapter 5, Chapter 7

19. EtherNet/IP COMMUNICATION

19.2 EtherNet/IP NETWORK CARD (LEC-S-N9)

The EtherNet/IP communication with an driver requires the EtherNet/IP Network card (LEC-S-N9). The following shows the details.

19.2.1 Specifications

Item	Description
Product name	LEC-S-N9
Model	AB6927-C
Manufacturer	HMS Industrial Networks
External interface	driver connecting interface: Compact flash connector with standard 50 pins EtherNet/IP communication port interface: RJ45 connector
Dimensions	52 (W) × 50 (D) × 20 (H) (Except the protrusion of the EtherNet/IP communication port connector)
Mass	Approx. 30 g

19.2.2 Parts identification

This section describes the EtherNet/IP Network card (LEC-S-N9) only. Refer to section 1.7 for the driver.

No.	Name/Application	Detailed explanation
(1)	Card Status LED Indicates the card status.	Section 2.3.2 (2)
(2)	RJ45 EtherNet/IP communication port (port 2) Connect an EtherNet/IP master upper side or a driver.	Section 2.4
(3)	Link/Activity LED (port 2) Indicates the link status of each EtherNet/IP communication port.	Section 2.3.2 (3)
(4)	RJ45 EtherNet/IP communication port (port 1) Connect an EtherNet/IP master upper side or a driver.	Section 2.4
(5)	Link/Activity LED (port 1) Indicates the link status of each EtherNet/IP communication port.	Section 2.3.2 (3)
(6)	Network Status LED Indicates the communication status.	Section 2.3.2 (1)

19. EtherNet/IP COMMUNICATION

19.2.3 LED indication

The LEDs of the EtherNet/IP Network card (LEC-S-N9) function according to the regulations of the EtherNet/IP standard (THE CIP NETWORKS LIBRARY Volume 2: EtherNet/IP Adaptation of CIP). Under certain conditions, the EtherNet/IP Network card (LEC-S-N9) indicates its status by its own specifications.

19.2.3.1 LED indication definition

The following shows the LED indication definitions.

LED status	Definition
Lit	An LED remains lit.
Extinguished	An LED remains extinguished.
Flickering 1	An LED is switching between lit and extinguished at 1 Hz cycles (every 500 ms).
Flickering 2	An LED flickers at an inconstant cycle. The cycle varies depending on the packet amount of Ethernet.

19.2.3.2 LED indication list

(1) Network Status LED

The Network Status LED indicates the EtherNet/IP communication status. The extinguished Network Status LED may be affected by the LED status of the Link/Activity LEDs.

LED status	Description
Extinguished	Indicates that the power is shut off or no IP address has been assigned.
Flickering 1 in green	Indicates that an IP address has been assigned and the EtherNet/IP Network card has not been connected to the network.
Lit in green	Indicates that a network connection has been established.
Flickering 1 in red	Indicates that a network connection timeout has occurred.
Lit in red	Indicates that duplication of an IP address has been detected. Indicates that a fatal error has occurred. This indication is specific to the EtherNet/IP Network card (ABCC-M40-EIP).
Flickering 1 alternately in green and red	Indicates that the driver and the network card are diagnosing themselves.

(2) Card Status LED

The Card Status LED indicates each status of the driver and the network card and an error in the EtherNet/IP communication.

LED status	Description
Extinguished	Indicates that the power is shut off.
Lit in green	Indicates that the driver and the network card operate normally.
Flickering 1 in green	Indicates that the settings of the driver and the network card are not completed.
Flickering 1 in red	Indicates that the self-diagnoses of the driver and the network card have detected minor malfunctions that can be solved.
Lit in red	Indicates that the self-diagnoses of the driver and the network card have detected major malfunctions that cannot be solved.
Flickering 1 alternately in green and red	Indicates that the driver and the network card are diagnosing themselves.

19. EtherNet/IP COMMUNICATION

(3) Link/Activity LED

The Link/Activity LEDs indicate the link status of each EtherNet/IP communication port.

LED status	Description
Extinguished	Indicates that the power supply is shut off or the link-unestablished state.
Lit in green	Indicates that the link is established without traffic. (100 Mbit/s)
Flickering 2 in green	Indicates that the link is established with traffic. (100 Mbit/s)
Lit in yellow	Indicates that the link is established without traffic. (10 Mbit/s)
Flickering 2 in yellow	Indicates that the link is established with traffic. (10 Mbit/s)

19.2.4 Connecting Ethernet cables

POINT
Use a twisted pair cable (double shielded) compliant with Ethernet Category 5e (100BASE-TX) or higher as an Ethernet cable. The maximum cable length between nodes is 100 m.

When the RJ45 EtherNet/IP communication ports (port 1 and port 2) are not used, leave these ports open.

driver

driver

driver

Upper
side

19. EtherNet/IP COMMUNICATION

19.3 I/O COMMUNICATION

The I/O communication can send and receive command data/feedback data between a master (upper side) and slaves (driver) at a constant cycle.

19.3.1 I/O communication cycle

Specify an I/O communication cycle by using the Forward_Open or Large_Forward_Open service of Class 06h Connection Manager Object through the Explicit message communication. Refer to (1) in this section for details.

(1) Communication cycle-related object

POINT
Set a proper value for Communication timeout time on connection establishment according to the machine configuration. If the Communication timeout time is set longer than necessary, it will take longer for the servo motor to stop at the occurrence of a communication error.

Establish the Explicit Message connection and the I/O Message connection by using the Forward_Open or Large_Forward_Open service for Class 06h - Connection Manager Object.

Use Transport Class 1 for the I/O connection and Transport Class 3 for the Explicit Messaging connection. Refer to "THE CIP NETWORKS LIBRARY Volume 1 Common Industrial Protocol (CIP™)" for details of Transport Class.

For the EtherNet/IP master, set the following parameters using the Forward_Open or Large_Forward_Open service.

If you need to frequently transfer data through the Explicit Message connection, establish the connection using the Forward_Open or Large_Forward_Open service. If you do not need to transfer data often through the Explicit Message communication, establishment of the connection is an option.

No.	Parameter	Data type	Description	I/O connection	Explicit Messaging connection
1	Priority/Time_tick	BYTE	Used to calculate request timeout information.	/	/
	Details of setting values				
	Tick Time	BIT 0 to BIT 3	Unit of the time specified by the Time-out_ticks parameter	0 to 15	0 to 15
	Priority	BIT 4	Priority of non-connection type messages	0: Normal	0: Normal
	Reserved	BIT 5 to BIT 7	/	0	0
2	Time-out_ticks	USINT	Used to calculate request timeout information.	0 to 255	0 to 255
3	O->T Network Connection ID	UDINT	Network Connection ID to be used for the local link, originator to target. This is the originator's CIP send connection ID.	00000000h to FFFFFFFFh	00000000h to FFFFFFFFh
4	T->O Network Connection ID	UDINT	Network Connection ID to be used for the local link, target to originator. This is the originator's CIP receive connection ID.	00000000h to FFFFFFFFh	00000000h to FFFFFFFFh
5	Connection Serial Number	UINT	A unique 16-bit value selected by the Connection Manager object in the connection originator	0000h to FFFFh	0000h to FFFFh

19. EtherNet/IP COMMUNICATION

No.	Parameter	Data type	Description	I/O connection	Explicit Messaging connection				
6	Originator Vendor ID	UINT	Vendor ID of an originator node	A value of Identity object instance attribute 1	A value of Identity object instance attribute 1				
7	Originator Serial Number	UDINT	Serial number of an originator node	A value of Identity object instance attribute 6	A value of Identity object instance attribute 6				
8	Connection Timeout Multiplier	USINT	Used to specify the multiplier applied to the RPI to obtain the connection timeout value.	0 to 7	0 to 7				
9	Reserved	Octet		0	0				
		Octet		0	0				
		Octet		0	0				
10	O->T RPI	UDINT	Requested packet transmission speed, originator to target. [μs]	1000 to 100000	100000 to 10000000				
11	O->T Network Connection Parameters	WORD/DWORD (Note 1)	Connection size Set a fixed size or a variable size.	0046h to 4C46h/ 00000046h to 2C000046h (Note 2)	0040h to 4040h/ 00000040h to 20000040h (Note 2)				
12	T->O RPI	UDINT	Requested packet transmission speed, target to originator [μs]	1000 to 100000	100000 to 10000000				
13	T->O Network Connection Parameters	WORD/DWORD (Note 1)	Connection size Set a fixed size or a variable size.	0046h to 4C46h/ 00000046h to 2C000046h	0040h to 4040h/ 00000040h to 20000040h (Note 2)				
14	Transport Type/Trigger	BYTE							
	Details of setting values								
	Transport Class					BIT 0 to BIT 3	Set a Transport Class to be used in data communication.	1	3
	Production Trigger					BIT 4 to BIT 6	Set a trigger condition of data transmission.	0: Cyclic 1: Change of state	2: Application object
	Direction	BIT 7	Indicates that an end point works on the connection as a client or server.	0: Client 1: Server	0: Client 1: Server				
15	Connection_Path_Size	USINT	The number of 16-bit words in the Connection_Path field.	0 to 255	0 to 255				
16	Connection_Path	Padded EPATH	Indicates the route to the Remote Target Device.	Set the IP address or the host name of the connection destination	Set the IP address or the host name of the connection destination				

Note 1. The data type of this parameter is a WORD for the Forward_Open service, and a DWORD for the Large_Forward_Open service.

Note 2. Multicast connections are not supported.

19. EtherNet/IP COMMUNICATION

(2) Network Connection Parameters format

(a) Forward_Open service

15	14	13	12	11	10	9	8	7	6	5	4	3	2	1	0
Redundant Owner	Connection Type	Reserved	Priority	Fixed/ Variable	Connection Size (in bytes)										

(b) Large_Forward_Open service

31	30	29	28	27	26	25	24-16	15-0
Redundant Owner	Connection Type	Reserved	Priority	Fixed/ Variable	Reserved	Connection Size (in bytes)		

19.3.2 I/O communication mapping

(1) I/O communication format (input)

The following table lists the communication data formats from the master (upper side) to slaves (driver). Instance numbers in the table correspond to the instance numbers of Assembly object.

Map number	Mapping initial setting	Expected application of the initial map
1st Output data (Instance 150)	1 Byte: Modes of operation (6060h) 1 Byte: Reserved 2 Byte: Controlword (6040h) 4 Byte: Target position (607Ah) 4 Byte: Target velocity (60FFh) 2 Byte: Target torque (6071h) 2 Byte: Reserved 4 Byte: Profile velocity (6081h) 4 Byte: Profile acceleration (6083h) 4 Byte: Profile deceleration (6084h) 4 Byte: Torque slope (6087h) 4 Byte: Instruction code 4 Byte: Writing data 2 Byte: Control DI 10 (2D0Ah) 2 Byte: User defined data 0 (Initial value: Control DI 1 (2D01h)) (Note) 2 Byte: User defined data 1 (Initial value: Control DI 2 (2D02h)) (Note) 2 Byte: User defined data 2 (Initial value: Control DI 3 (2D03h)) (Note) 4 Byte: User defined data 3 (Initial value: Velocity limit value (2D20h)) (Note) 4 Byte: User defined data 4 (Initial value: Not assigned) (Note) 4 Byte: User defined data 5 (Initial value: Not assigned) (Note) 4 Byte: User defined data 6 (Initial value: Not assigned) (Note)	Profile position mode (pp) Profile velocity mode (pv) Profile torque mode (tq) Homing mode (hm) Mapping for an application in which the modes above are switched Map size: 64 bytes

Note. User defined data 0 to User defined data 6 are variable objects.

19. EtherNet/IP COMMUNICATION

(2) I/O communication format (output)

The following table lists the communication data formats from slaves (driver) to the master (upper side). Instance numbers in the table correspond to the instance numbers of Assembly object.

Map number	Mapping initial setting	Expected application of the initial map
1st Input map (Instance 100)	1 Byte: Modes of operation display (6061h) 1 Byte: Reserved 2 Byte: Statusword (6041h) 4 Byte: Position actual value (6064h) 4 Byte: Velocity actual value (606Ch) 2 Byte: Torque actual value (6077h) 2 Byte: Reserved 4 Byte: Reading data 2 Byte: Respond code 2 Byte: Status DO 10 (2D1Ah) 2 Byte: User defined data 0 (Initial value: Status DO 1 (2D11h)) (Note) 2 Byte: User defined data 1 (Initial value: Status DO 2 (2D12h)) (Note) 2 Byte: User defined data 2 (Initial value: Status DO 3 (2D13h)) (Note) 2 Byte: Reserved 4 Byte: User defined data 3 (Initial value: Following error actual value (60F4h)) (Note) 4 Byte: User defined data 4 (Initial value: Digital Input (60FDh)) (Note) 4 Byte: User defined data 5 (Initial value: Not assigned) (Note) 4 Byte: User defined data 6 (Initial value: Not assigned) (Note) 16 Byte: Reserved	Profile position mode (pp) Profile velocity mode (pv) Profile torque mode (tq) Homing mode (hm) Mapping for an application in which the modes above are switched Map size: 64 bytes

Note. User defined data 0 to User defined data 6 are variable objects.

(3) Variable mapping function

The instances defined by User defined data_ can be dynamically switched to any send instance or receive instance. Use instruction codes for switching instances. Refer to section 6.2 for details.

19. EtherNet/IP COMMUNICATION

19.4 Explicit Message COMMUNICATION

The Explicit Message communication transfers object data between a master (upper side) and slaves (driver) asynchronously.

Services that can be used through the Explicit Message communication depend on their classes and instances. Refer to chapter 7 for the services that are supported by each class and instance. Refer to "THE CIP NETWORKS LIBRARY Volume 1 Common Industrial Protocol (CIP™) Appendix A" for details of each service.

19.4.1 Explicit Message communication-related service

The driver supports the following common services and object-specific services that are related to the Explicit Message communication. Refer to chapter 7 for the object-specific services. Refer to section 4.2 for the common services.

(1) Common service

Service	Description
Set_Attribute_Single	Writes a value to the specified attribute.
Get_Attribute_Single	Reads the value of the specified attribute.
Get_Attributes_All	Reads the values of all the attributes.
Reset	Calls the Reset service of the specified class/object.

(2) Object-specific service

Service	Description
Large_Forward_Open	Used in the Connection Manager Object.
Forward_Open	Used in the Connection Manager Object.
Forward_Close	Used in the Connection Manager Object.
Get_And_Clear	Used in the Ethernet Link Object.

19. EtherNet/IP COMMUNICATION

19.4.2 Common service

The general status codes in this section are codes _ drivers respond. The codes network cards respond are not included. Refer to "General Status Codes" of "THE CIP NETWORKS LIBRARY Volume 1 Common Industrial Protocol (CIP™) Appendix A" for all the general status codes.

19.4.2.1 Set_Attribute_Single

When a Set_Attribute_Single request is sent from the master (upper side), the Set_Attribute_Single service writes a specified value to the attribute with the Class ID, Instance ID, and Attribute ID specified at the timing of the request.

This service returns either of the following general status codes depending on conditions.

General status code	Meaning	Cause
05h	Path destination unknown	A non-existent object or instance has been specified.
14h	Attribute not supported	A non-existent attribute has been specified.
0Eh	Attribute not settable	A value was written to a non-modifiable attribute.
09h	Invalid attribute value	A value outside the parameter range was written.
1Eh	Embedded service error	A value was written to a parameter outside the writing range set in the parameter block setting.
08h	Service not supported	A request was issued to a class and an instance that do not support the Set_Attribute_Single service.

19.4.2.2 Get_Attribute_Single

When a Get_Attribute_Single request is sent from the master (upper side), the Get_Attribute_Single service returns the value of the attribute with the Class ID, Instance ID, and Attribute ID specified at the timing of the request.

This service returns either of the following general status codes depending on conditions.

General status code	Meaning	Cause
05h	Path destination unknown	A non-existent object or instance has been specified.
14h	Attribute not supported	A non-existent attribute has been specified.
2Ch	Attribute not gettable	Reading an unreadable attribute was attempted.
1Eh	Embedded service error	Reading a parameter object outside the reference range set in the parameter block setting was attempted.
08h	Service not supported	A request was issued to a class and an instance that do not support the Get_Attribute_Single service.

19.4.2.3 Get_Attributes_All

When a Get_Attributes_All request is sent from the master (upper side), the Get_Attributes_All service returns the values of all the attributes with the Class IDs and Instance IDs specified at the timing of the request.

This service returns either of the following general status codes depending on conditions.

General status code	Meaning	Cause
05h	Path destination unknown	A non-existent object or instance has been specified.
2Ch	Attribute not gettable	Reading an unreadable attribute was attempted.
1Eh	Embedded service error	Reading a parameter object outside the reference range set in the parameter block setting was attempted.
08h	Service not supported	A request was issued to a class and an instance that do not support the Get_Attributes_All service.

19. EtherNet/IP COMMUNICATION

19.4.2.4 Reset

When a Reset request is sent from the master (upper side), the Reset service performs the reset processing that was specified by the Class ID, Instance ID, and object-specific parameter that were specified at the timing of the request. The processing to be performed when a Reset request is received depends on the object. Refer to section 7.3.1 (1) for details.

This service returns either of the following general status codes depending on conditions.

General status code	Meaning	Cause
20h	Invalid parameter	An unsupported reset type was specified.
08h	Service not supported	A request was issued to a class and an instance that do not support the Reset service.

19.5 DRIVE PROFILE

19.5.1 FSA state

The inside state of the driver is controlled based on the FSA state, defined in the CiA 402 drive profile standard. Figure 5.1 and Table 5.1 show the transition conditions between the FSA states. The states are switched when the master sends a command following the table (sets Controlword) after the I/O communication was established. When the state has transitioned from Not ready to switch on, which is right after the power on, to Operation enabled with the predetermined procedure, the servo motor becomes ready to operate.

Figure 5.1 Transition between the FSA states

Table 5.1 State transition

Transition No.	Event	Remark
(0)	The control circuit power supply is turned on.	Initialization
(1)	The state automatically transitions when the control circuit power supply is turned on.	Communication setting
(2)	The state transitions with the Shutdown command from the master.	
(3)	The state transitions with the Switch on command from the master.	RA turns on.
(4)	The state transitions with the Enable operation command from the master.	The operation becomes ready after servo-on.
(5)	The state transitions with the Disable operation command from the master.	The operation is disabled after servo-off.
(6)	The state transitions with the Shutdown command from the master.	RA turns off.
(7)	The state transitions with the Disable Voltage command or Quick Stop command from the master.	
(8)	(a) The state transitions with the Shutdown command from the master. (b) The state transitions when the main circuit power supply is turned off.	Operation is disabled after servo-off or RA-off.
(9)	The state transitions with the Disable Voltage command from the master.	Operation is disabled after servo-off or RA-off.
(10)	The state transitions with the Disable Voltage command or Quick Stop command from the master.	RA turns off.
(11)	The state transitions with the Quick Stop command from the master.	Quick Stop starts.
(12)	(a) The state automatically transitions after Quick Stop is completed. (If the Quick Stop option code is 1, 2, 3, or 4) (b) The state transitions with the Disable Voltage command from the master.	Operation is disabled after servo-off or RA-off.
(13)	Alarm occurrence	Processing against the alarm is executed.

19. EtherNet/IP COMMUNICATION

Transition No.	Event	Remark
(14)	Automatic transition	After processing against the alarm has been completed, servo-off or RA-off is performed and the operation is disabled.
(15)	The state transitions with the Fault Reset command from the master.	Alarms are reset. Alarms that can be reset are reset.
(16) (Not supported) (Note)	The state transitions with the Enable Operation command from the master. (If the Quick Stop option code is 5, 6, 7, or 8)	The operation becomes ready.

No	This is not supported by the driver.
----	--------------------------------------

The following table lists the commands issued to the driver. Turn on the bits according to the command.

Command	Command bit setting of Controlword					Transition No.
	Bit 7 Fault Reset	Bit 3 Enable Operation	Bit 2 Quick Stop	Bit 1 Enable Voltage	Bit 0 Switch On	
Shutdown	0		1	1	0	(2)/(6)/(8)
Switch On	0	0	1	1	1	(3)
Disable Voltage	0			0		(7)/(9)/(10)/(12)
Quick Stop	0		0	1		(7)/(10)/(11)
Disable Operation	0	0	1	1	1	(5)
Enable Operation	0	1	1	1	1	(4)/(16)
Fault Reset	0 → 1 (Note)					(15)

Note. In faulty communication, hold the state of Bit 7 = 1 according to the communication cycle for the Fault Reset command to prevent the command from failing to be recognized.

When the time determined by doubling the communication cycle is 10 ms or shorter: Hold the state for 10 ms.

When the time determined by doubling the communication cycle is longer than 10 ms: Hold the state for the time determined by doubling the communication cycle.

The above time has been defined to prevent the Fault Reset command from failing to be recognized when a communication loss occurs. A communication loss occurs frequently depending on the operating environment of the device. Adjust the time according to the environment.

Figure 5.1 and Table 5.1 show the FSA state transition conditions. The transition from the Switch on disabled state to the Operation enabled state requires Shutdown, Switch on, and Enable operation to be issued in this order. However, with the driver, transition to the target state skipping the states in between is possible.

Current state	Command	State after transition
Switch on disabled	Switch on	Switched on
Switch on disabled	Enable operation	Operation enabled
Ready to switch on	Enable operation	Operation enabled

19. EtherNet/IP COMMUNICATION

19.5.2 Controlword/Control DI

The FSA state can be switched and control commands for the functions of the drive can be issued by rewriting the objects of the following Controlword and Control DI from the master (upper side).

Class ID	Ins ID	Attr ID	Access	Name	Data Type	Description
64h	6040h	0	Get/Set	Controlword	UINT	Control commands to control the driver can be set.
	2D01h	0	Get/Set	Control DI 1	UINT	
	2D02h			Control DI 2		
	2D03h			Control DI 3		
	2D07h			Control DI 7		
	2D0Ah			Control DI 10		

19.5.2.1 Bit definition of Controlword

Controlword can control the FSA state and issue control commands. Use Bit 0 to Bit 3 and Bit 7 for the FSA state. The following table shows the bit definition of Controlword.

Bit	Symbol	Description
0	SO	Switch-on
1	EV	Enable voltage
2	QS	Quick stop
3	EO	Enable operation
4	OMS	Differs depending on Modes of operation (Class ID: 64h, Ins ID: 6060h, Attr ID: 0). (Refer to section 5.4.)
5		
6		
7	FR	Fault reset
8	HALT	0: Operation ready 1: Temporary stop
9	OMS	Differs depending on Modes of operation (Class ID: 64h, Ins ID: 6060h, Attr ID: 0). (Refer to section 5.4.)
10		The value at reading is undefined. Set "0" at writing.
11		
12		
13		
14		
15		

19. EtherNet/IP COMMUNICATION

19.5.2.2 Bit definition of Control DI

Control DI can control the FSA state and issue control commands. The following table shows the bit definition of Control DI.

(1) Control DI 1

Bit	Symbol	Description
0		The value at reading is undefined. Set "0" at writing.
1		
2		
3		
4	C_CDP	Gain switching Turn on C_CDP to use the values of [Pr. PB29] to [Pr. PB36] and [Pr. PB56] to [Pr. PB60] as the load to motor inertia ratio and gain values.
5		The value at reading is undefined. Set "0" at writing.
6		
7		
8		
9		
10		
11		
12		
13		
14		
15		

(2) Control DI 2

Bit	Symbol	Description
0		The value at reading is undefined. Set "0" at writing.
1		
2		
3		
4		
5		
6		
7		
8	C_PC	Proportional control Turn C_PC on to switch the speed amplifier from the proportional integral type to the proportional type. If the servo motor at a stop is rotated even one pulse due to any external factor, it generates torque to compensate for a position mismatch. When the servo motor shaft is to be locked mechanically after positioning completion (stop), switching on the C_PC upon positioning completion will suppress the unnecessary torque generated to compensate for a position mismatch. When the shaft is to be locked for a long time, use the C_PC and torque limit at the same time to make the torque less than the rated torque.
9		The value at reading is undefined. Set "0" at writing.
10		
11		
12		
13		
14		
15	C_ORST	Operation alarm reset Turn on C_ORST from off to reset [AL. F4 Positioning warning].

19. EtherNet/IP COMMUNICATION

(3) Control DI 3

Bit	Symbol	Description
0		The value at reading is undefined. Set "0" at writing.
1		
2		
3		
4		
5		
6		
7		
8	C_ABS2	Home position return completion (for scale measurement) When C_ABS2 is turned on with the scale measurement function, the absolute position erased status of a scale measurement encoder can be canceled. S_ABSV2 turns off.
9		The value at reading is undefined. Set "0" at writing.
10		
11		
12		
13		
14		
15		

(4) Control DI 7

Bit	Symbol	Description
0		The value at reading is undefined. Set "0" at writing.
1		
2		
3		
4		
5		
6		
7		
8		
9		
10		
11		
12	C_STS	Synchronous control command (Note) 0: Synchronous control termination 1: Synchronous control start Turn on C_STS with the network communication to start the synchronous control. When a value of the synchronous encoder electronic gear was changed with the network communication, turn on Synchronous control command (C_STS) after Analysis completed (S_CEG) is turned on.
13	C_POL	Synchronous encoder polarity selection (Note) 0: Rotating the synchronous encoder in the CCW direction or the positive direction increases the command address. 1: Rotating the synchronous encoder in the CW direction or the negative direction increases the command address. Set a synchronous encoder polarity according to the specifications of an encoder used. A setting value when Synchronous control command (C_STS) is turned on will be applied.
14	C_CEG	Analysis command (Note) 0: Synchronous encoder electronic gear change termination 1: Synchronous encoder electronic gear change start After changing the synchronous encoder electronic gear, turn on Analysis command (C_CEG). After Analysis completed (S_CEG) is turned on, the change of the synchronous encoder electronic gear will be applied and it will be used by the synchronous control.
15		The value at reading is undefined. Set "0" at writing.

Note. Refer to section 6.10 for details.

19. EtherNet/IP COMMUNICATION

(5) Control DI 10

Bit	Symbol	Description
0		The value at reading is undefined. Set "0" at writing.
1	C_SPR	Instruction code request (Note 1) Turning on C_SPR executes the set instruction code.
2	C_OSSA	Operation start-up signal activation (Note 2) Turning on C_OSSA enables the positioning start by the operation start-up signal.
3		The value at reading is undefined. Set "0" at writing.
4		
5		
6		
7		
8		
9		
10		
11		
12		
13		
14		
15		

- Note 1. Refer to section 6.2 for details.
 Note 2. Refer to section 6.11 for details.

19. EtherNet/IP COMMUNICATION

19.5.3 Statusword/Status DO

The objects of the following Statusword or Status DO notify the master (upper side) of the FSA state of the _ driver and other drive status.

Class ID	Ins ID	Attr ID	Access	Name	Data Type	Description
64h	6041h	0	Get	Statusword	UINT	The servo status is returned.
	2D11h	0	Get	Status DO 1	UINT	
	2D12h			Status DO 2		
	2D13h			Status DO 3		
	2D15h			Status DO 5		
	2D16h			Status DO 6		
	2D17h			Status DO 7		
	2D1Ah			Status DO 10		

19.5.3.1 Bit definition of Statusword

The following table shows the bit definition of Statusword.

Bit	Symbol	Description
0	RTSO	Ready-to-switch-on
1	SO	Switch-on
2	OE	Operation-enabled
3	F	Fault
4	VE	Voltage-enabled 0: The bus voltage is lower than the certain (RA) level. 1: The bus voltage is equal to or higher than the certain level.
5	QS	Quick stop 0: During a quick stop 1: No during a quick stop (including during the test mode)
6	SOD	Switch on disabled
7	W	Warning 0: No warning has been occurred. 1: A warning has occurred.
8		The value at reading is undefined.
9	RM	Remote 0: Not following the Controlword command 1: In operation following the Controlword command
10	TR	Target reached Differs depending on Modes of operation (Class ID: 64h, Ins ID: 6060h, Attr ID: 0). (Refer to section 5.4.)
11	ILA	Internal limit active 0: The forward rotation stroke end, reverse rotation stroke end, and software position limit have not been reached 1: The forward rotation stroke end, reverse rotation stroke end, or software position limit has been reached. (Enabled in the pp, pv, or hm mode)
12	OMS	Differs depending on Modes of operation (Class ID: 64h, Ins ID: 6060h, Attr ID: 0). (Refer to section 5.4.)
13		
14		
15		The value at reading is undefined.

19. EtherNet/IP COMMUNICATION

Bit 0 to Bit 3, Bit 5, and Bit 6 are switched depending on the FSA state (internal state of the _ driver). Refer to the following table for details.

Statusword (bin)	FSA state
x0xx xxx0 x0xx 0000	Not ready to switch on (Note)
x0xx xxx0 x1xx 0000	Switch on disabled
x0xx xxx0 x01x 0001	Ready to switch on
x0xx xxx0 x01x 0011	Switched on
x0xx xxx0 x01x 0111	Operation enabled
x0xx xxx0 x00x 0111	Quick stop active
x0xx xxx0 x0xx 1111	Fault reaction active
x0xx xxx0 x0xx 1000	Fault

Note. Statusword is not sent in the Not ready to switch on state.

19.5.3.2 Bit definition of Status DO

The following table shows the bit definition of Status DO.

(1) Status DO 1

Bit	Symbol	Description
0		The value at reading is undefined.
1		
2	S_SA	Speed reached S_SA turns off during servo-off. When the servo motor speed reaches the following range, S_SA turns on. Preset speed $\pm ((\text{Preset speed} \times 0.05) + 20)$ r/min When the preset speed is 20 r/min or slower, S_SA always turns on.
3	S_MBR	Electromagnetic brake interlock When a servo-off status or alarm occurs, S_MBR turns off.
4	S_CDPS	Variable gain selection S_CDPS will turn on during variable gain.
5	S_CLD	During fully closed loop control switching S_CLD turns on during fully closed loop control.
6		The value at reading is undefined.
7		
8		
9		
10		
11		
12	S_INP	In-position When the number of droop pulses is in the in-position range, S_INP turns on. The in-position range can be changed with [Pr. PA10]. When the in-position range is increased, S_INP may be always on during low-speed rotation. The Status DO cannot be used in the velocity mode or torque mode.
13	S_TLC	Limiting torque When the torque reaches the torque limit value during torque generation, S_TLC turns on. When the servo is off, S_TLC will be turned off. This Status DO cannot be used in the torque mode.
14	S_ABSV	Absolute position undetermined When the absolute position is erased, S_ABSV turns on. The Status DO cannot be used in the velocity mode or torque mode.
15	S_BWNG	Battery warning When [AL. 92 Battery cable disconnection warning] or [AL. 9F Battery warning] has occurred, S_BWNG turns on. When the battery warning is not occurring, turning on the power will turn off S_BWNG after 2.5 s to 3.5 s.

19. EtherNet/IP COMMUNICATION

(2) Status DO 2

Bit	Symbol	Description
0	S_ZPAS	Z-phase already passed 0: Z-phase unpassed after start-up 1: Z-phase passed once or more after start-up
1		The value at reading is undefined.
2		
3	S_ZSP	Zero speed detection When the servo motor speed is at zero speed or slower, S_ZSP turns on. Zero speed can be changed with [Pr. PC07].
4	S_VLC	Limiting speed When the speed reaches the speed limit value in the torque mode, S_VLC turns on. When the servo is off, S_TLC will be turned off. The Status DO cannot be used in the position mode or velocity mode.
5		The value at reading is undefined.
6		S_IPF
7		
8	S_PC	Under proportional control S_PC turns on under proportional control.
9		The value at reading is undefined.
10	S_DB	External dynamic brake output When the dynamic brake needs to operate, S_DB turns off.
11		The value at reading is undefined.
12		
13		
14		
15	S_ZP2	Home position return completion 2 (incremental system) When a home position return completes normally, S_ZP2 turns on. S_ZP2 is always on unless the home position is erased. It will be off with the following conditions. 1) [AL. 69 Command error] occurs. 2) Home position return is not being executed. 3) Home position return is in progress.
		Home position return completion 2 (absolute position detection system) If a home position return completes once, S_ZP2 is always on. However, it will be off with the following conditions. 1) [AL. 69 Command error] occurs. 2) Home position return is not being executed. 3) Home position return is in progress. 4) The home position return is not performed after [AL. 25 Absolute position erased] or [AL. E3 Absolute position counter warning] occurred. 5) The home position return is not performed after the electronic gear ([Pr. PA06] or [Pr. PA07]) was changed. 6) The home position return is not performed after the setting of [Pr. PA03 Absolute position detection system selection] was changed from "Disabled" to "Enabled". 7) [Pr. PA14 Rotation direction selection] was changed. 8) [Pr. PA01 Operation mode] was changed.

19. EtherNet/IP COMMUNICATION

(3) Status DO 3

Bit	Symbol	Description
0		The value at reading is undefined.
1		
2		
3		
4		
5	S_STO	During STO S_STO turns on during STO.
6		The value at reading is undefined.
7		
8	S_ABSV2	Absolute position undetermined 2 (for scale measurement) When the absolute position is erased from a scale measurement encoder with the scale measurement function, S_ABSV2 turns on.
9		The value at reading is undefined.
10		
11	S_MTTR	Transition to tough drive mode in process When a tough drive is "Enabled" in [Pr. PA20], activating the instantaneous power failure tough drive will turn on S_MTTR.
12		The value at reading is undefined.
13		
14		
15		

(4) Status DO 5

Bit	Symbol	Description
0		The value at reading is undefined.
1		
2		
3		
4		
5		
6	S_MEND	Travel completion When the droop pulses are within the in-position output range set with [Pr. PA10] and the command remaining distance is "0", S_MEND will be on. S_MEND turns on with servo-on. S_MEND is off at servo-off status.
7		The value at reading is undefined.
8		
9		
10		
11		
12		
13		
14		
15		

19. EtherNet/IP COMMUNICATION

(5) Status DO 6

Bit	Symbol	Description
0	/	The value at reading is undefined.
1		
2		
3		
4		
5		
6		
7		
8		
9		
10		
11		
12		
13		
14	S_CEG	Analysis completed (Note) 0: Synchronous encoder electronic gear change not completed 1: Synchronous encoder electronic gear change completed Indicates that the synchronous encoder electronic gear change has been completed.
15	S_SYCREV	Synchronous control start-up completed (Note) 0: Synchronous control command not received 1: Synchronous control command received Indicates that Synchronous control command has been received properly.

Note. Refer to section 6.10 for details.

(6) Status DO 7

Bit	Symbol	Description		
0	/	The value at reading is undefined.		
1				
2				
3				
4				
5				
6				
7				
8				
9	S_SRUN	Synchronous control in progress (Note) 0: Synchronous control not in progress 1: Synchronous control in progress Indicates that the synchronous control is in progress.		
10	S_SERR	Synchronous control error (Note) 0: Synchronous control properly in progress 1: Synchronous control error Indicates that an error has occurred in the synchronous control.		
11	S_YRUN	Superimposed control in progress (Note) 0: Superimposed control not in progress 1: Superimposed control in progress Indicates that the superimposed control is in progress.		
12	S_YERR	Superimposed control error (Note) 0: Superimposed control properly in progress 1: Superimposed control error Indicates that an error has occurred in the superimposed control.		
13	/	The value at reading is undefined.		
14			S_SYC	Synchronization completed (Note) 0: Synchronous control not completed 1: Synchronous control completed Indicates that the rotation position of the synchronous encoder has synchronized with that of the servo motor.
15			S_SYF	Superposition completed (Note) 0: Superimposed control not completed 1: Superimposed control completed Indicates that the superimposed control has been completed.

Note. Refer to section 6.10 for details.

19. EtherNet/IP COMMUNICATION

(7) Status DO 10

Bit	Symbol	Description
0		The value at reading is undefined.
1	S_COF	Instruction code execution completion (Note 1) S_COF turns on when an instruction code is executed.
2	S_OERR	Operation error (Note 2) S_OERR turns on when an error occurs in the positioning operation started by the operation start-up signal.
3		The value at reading is undefined.
4		
5		
6		
7		
8		
9		
10		
11		
12		
13		
14		
15		

- Note 1. Refer to section 6.2 for details.
2. Refer to section 6.11 for details.

19. EtherNet/IP COMMUNICATION

19.5.4 Control mode

19.5.4.1 Selecting control mode (Modes of operation)

Specify a control mode with Modes of operation (Class ID: 64h, Ins ID: 6060h, Attr ID: 0). Modes of operation (Class ID: 64h, Ins ID: 6060h, Attr ID: 0) can be rewritten with the I/O communication or the Explicit Message communication.

Pr. PA01 setting value	p p	p v	t q	h m	6060h/6061h Default value
___ 0: Automatic selection by each network	<input type="radio"/>	<input type="radio"/>	<input type="radio"/>	<input type="radio"/>	1 (pp)
___ 2: Profile mode	<input type="radio"/>	<input type="radio"/>	<input type="radio"/>	<input type="radio"/>	

The following table shows the objects selected for control modes.

Class ID	Ins ID	Attr ID	Access	Name	Data Type	Default	Description
64h	6060h	0	Get/Set	Modes of operation	SINT	Differs depending on [Pr. PA01].	Refer to section 7.3.8 (6).
	6061h	0	Get	Modes of operation display	SINT	Differs depending on [Pr. PA01].	Refer to section 7.3.8 (7).
	6502h	0	Get	Supported drive mode	UDINT	Refer to section 7.3.8 (8).	Refer to section 7.3.8 (8).

19.5.4.2 Control switching

POINT
<ul style="list-style-type: none"> ● Changes to the OMS bit of Controlword (Class ID: 64h, Ins ID: 6040h, Attr ID: 0) are not accepted until control switching is completed. Before inputting commands, check that the control mode has been switched referring to Modes of operation display (Class ID: 64h, Ins ID: 6061h, Attr ID: 0).

Because control switching has a delay, the upper side must keep sending command values corresponding to the control mode before and after the switching. After the completion of control switching has been checked with Modes of operation display (Class ID: 64h, Ins ID: 6061h, Attr ID: 0), update of the command value before the switching can be stopped.

Before switching the mode from or to the position mode, check that the servo motor speed is zero speed. Zero speed can be obtained with Bit 3 (S_ZSP) of Status DO 2 (Class ID: 64h, Ins ID: 2D12h, Attr ID: 0). If the servo motor speed is not zero speed, the control will not be switched and Modes of operation display (Class ID: 64h, Ins ID: 6061h, Attr ID: 0) will not change.

19. EtherNet/IP COMMUNICATION

19.5.4.3 Profile position mode (pp)

The following shows the functions and related objects of the profile position mode (pp).

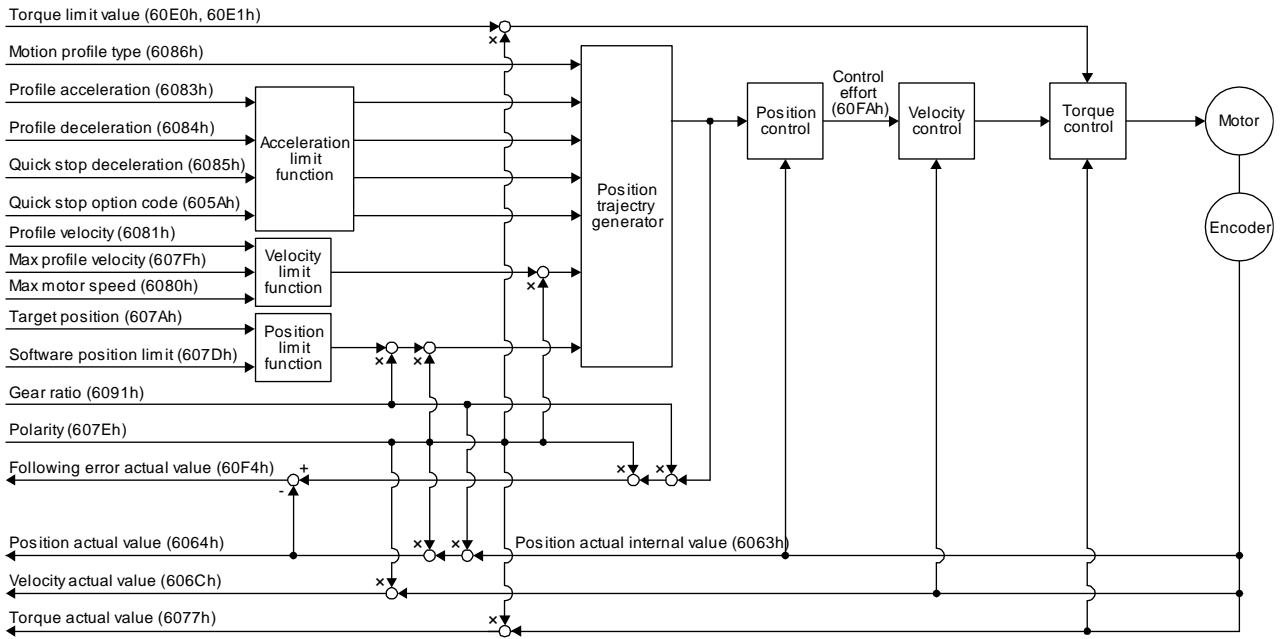

(1) Related object

Class ID	Ins ID	Attr ID	Access	Name	Data Type	Default	Description
64h	607Ah	0	Get/Set	Target position	DINT		Command position (Pos units)
	607Bh	0	Get	Position range limit	USINT	2	Number of entries
		1	Get/Set	Min position range limit	DINT		Minimum value of the position range limit The value is automatically set according to the setting of "Position data unit" in [Pr. PT01]. mm/inch/pulse: -2147483648 degree: 0
		2	Get/Set	Max position range limit	DINT		Maximum value of the position range limit The value is automatically set according to the setting of "Position data unit" in [Pr. PT01]. mm/inch/pulse: 2147483647 degree: 359999
	607Dh	0	Get	Software position limit	USINT	2	Number of entries
		1	Get/Set	Min position limit	DINT	0	Minimum position address (Pos units)
		2	Get/Set	Max position limit	DINT	0	Maximum position address (Pos units)
	607Fh	0	Get/Set	Max profile velocity	UDINT	2000000	maximum speed Unit: Vel unit (0.01 r/min or 0.01 mm/s)
	6080h	0	Get/Set	Max motor speed	UDINT		Servo motor maximum speed Unit: r/min
	6081h	0	Get/Set	Profile velocity	UDINT	10000	Speed after acceleration completed Unit: Vel unit (0.01 r/min or 0.01

19. EtherNet/IP COMMUNICATION

Class ID	Ins ID	Attr ID	Access	Name	Data Type	Default	Description
							mm/s)

Class ID	Ins ID	Attr ID	Access	Name	Data Type	Default	Description
64h	6083h	0	Get/Set	Profile Acceleration	UDI NT	0	Acceleration at start of movement to target position Unit: ms
	6084h	0	Get/Set	Profile deceleration	UDI NT	0	Deceleration at arrival at target position Unit: ms
	6085h	0	Get/Set	Quick stop deceleration	UDI NT	100	Deceleration at deceleration to a stop by Quick stop Unit: ms
	6086h	0	Get/Set	Motion profile type	INT	-1	Acceleration/deceleration type selection -1: S-pattern 0: Linear ramp (not supported) (Note) 1: Sin ² ramp (not supported) (Note) 2: Jerk-free ramp (not supported) (Note) 3: Jerk-limited ramp (not supported) (Note)
	605Ah	0	Get/Set	Quick stop option code	INT	2	Operation setting for Quick stop Refer to section 5.6.
	6063h	0	Get	Position actual internal value	DIN T		Current position (Enc inc)
	6064h	0	Get	Position actual value	DIN T		Current position (Pos units)
	606Ch	0	Get	Velocity actual value	DIN T		Current speed Unit: Vel unit (0.01 r/min or 0.01 mm/s)
	6077h	0	Get	Torque actual value	DIN T		Current torque Unit: 0.1% (rated torque of 100%)
	6092h	0	Get	Feed constant	USI NT	2	Travel distance per revolution of an output shaft
		1	Get/Set	Feed	UDI NT		Travel distance Refer to section 7.3.14 (4).
		2		Shaft revolutions			Number of servo motor shaft revolutions Refer to section 7.3.14 (4).
	60F4h	0	Get	Following error actual value	DIN T		Droop pulses (Pos units)
	60FAh	0	Get	Control effort	DIN T		Position control loop output (speed command) Unit: Vel unit (0.01 r/min or 0.01 mm/s)
	60E0h	0	Get/Set	Positive torque limit value	UIN T	1000 0	Torque limit value (forward) Unit: 0.1% (rated torque of 100%)
	60E1h	0	Get/Set	Negative torque limit value	UIN T	1000 0	Torque limit value (reverse) Unit: 0.1% (rated torque of 100%)
	6091h	0	Get	Gear ratio	USI NT	2	Gear ratio
		1	Get/Set	Motor revolutions	UDI NT	1	Number of revolutions of the servo motor axis (numerator)
		2		Shaft revolutions		1	Number of revolutions of the drive axis (denominator)
	607Eh	0	Get/Set	Polarity	USI NT	0	Polarity selection Bit 7: Position POL Bit 6: Velocity POL Bit 5: Torque POL Refer to section 5.10.

19. EtherNet/IP COMMUNICATION

Class ID	Ins ID	Attr ID	Access	Name	Data Type	Default	Description
64h	60A8h	0	Get/Set	SI unit position	UDINT	0	SI unit position The value is automatically set according to the setting of "Position data unit" of [Pr. PT01]. Refer to section 7.3.14 (5).
	60A9h	0	Get/Set	SI unit velocity	UDINT	0	SI unit velocity 0.01 r/min or 0.01 mm/s FB010300h (0.01 mm/s) FEB44700h (0.01 r/min)

Note. This is not supported by the driver.

(2) Details on the OMS bit of Controlword (pp mode)

Bit	Symbol	Description
4	New set-point	New positioning parameters are obtained when this bit turns on. Turning on this will start the superimposed synchronous control when the superimposed synchronous control is used.
5	Change set immediately	0: Set of set-points 1: Single set-point
6	abs/rel	0: Absolute position command 1: Relative position command When the unit is set to degree, relative position commands are disabled. When the relative position command is specified and positioning is started, [AL. F4.8] occurs and positioning cannot be started.
8	HALT	0: Positioning is executed. 1: The servo motor stops according to Halt option code (Class ID: 64h, Ins ID: 605Dh, Attr ID: 0).
9	Change on set-point	Enabled only for Set of set-points (Bit 5 = 0). 0: The next positioning starts after the current positioning is completed (stopped). (black line (Refer to (5) in this section.)). 1: The next positioning starts after positioning is executed with Profile velocity (Class ID: 64h, Ins ID: 6081h, Attr ID: 0) held up to the current set-point. (gray line (Refer to (5) in this section.)).

(3) Details on the OMS bit of Statusword (pp mode)

Bit	Symbol	Description
10	Target reached	0 (Halt (Bit 8) = 0): Target position not reached. 0 (Halt (Bit 8) = 1): Axis decelerates 1 (Halt (Bit 8) = 0): Target position reached. 1 (Halt (Bit 8) = 1): Velocity of axis is 0 Judgment condition for Target position reached If the error between Position actual value (Class ID: 64h, Ins ID: 6064h, Attr ID: 0) and Target position (Class ID: 64h, Ins ID: 607Ah, Attr ID: 0) has stayed within Position window (Class ID: 64h, Ins ID: 6067h, Attr ID: 0) for Position window time (Class ID: 64h, Ins ID: 6068h, Attr ID: 0) or more, Target position reached is stored.
12	Set-point acknowledge	0: Positioning completed (wait for next command) 1: Positioning being executed (The set-point can be overwritten.)
13	Following error	0: No following error 1: Following error Judgment condition for Following error When the time set with Following error time out (Class ID: 64h, Ins ID: 6066h, Attr ID: 0) has elapsed with the number of droop pulses exceeding the set value of the Following error window (Class ID: 64h, Ins ID: 6065h, Attr ID: 0), this bit becomes "1".

(4) Single Set-point

Update of positioning parameters during a positioning operation is immediately accepted. (The current positioning operation is cancelled and the next positioning is started.)

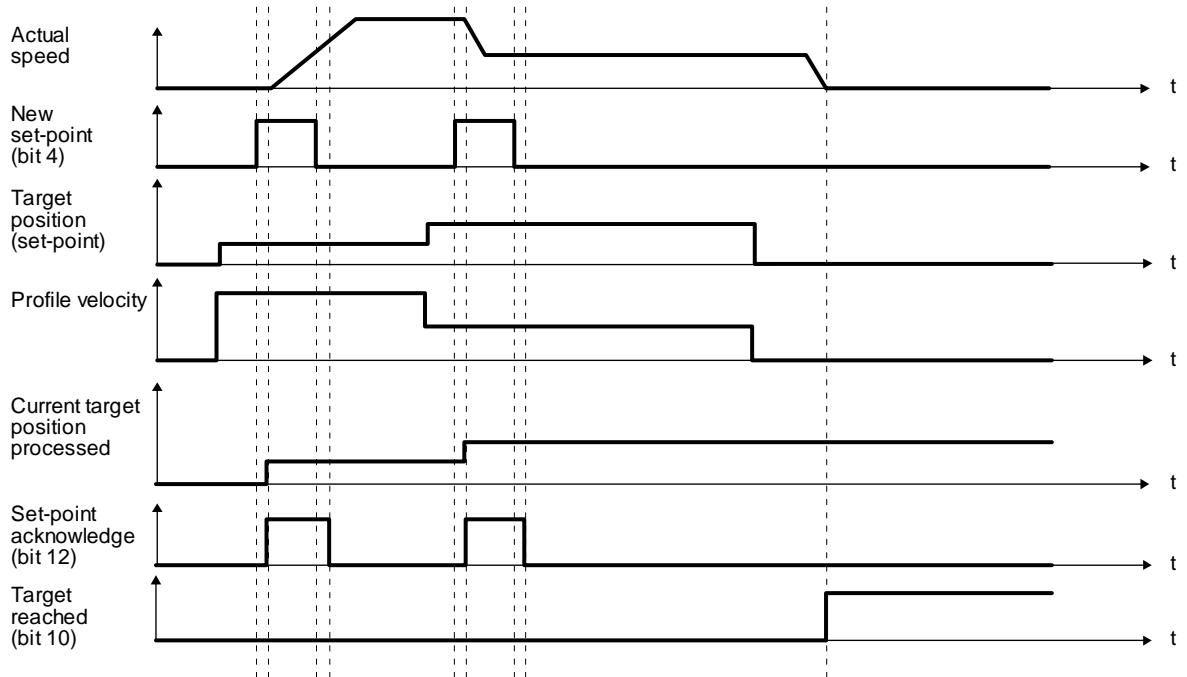

(5) Set of set-points

After the current positioning operation is completed, the next positioning is started. Whether positioning is stopped at the first positioning point when at an update of the positioning parameter before completion of the positioning can be switched. To switch the setting, use Change on set-point (Bit 9 of Controlword).

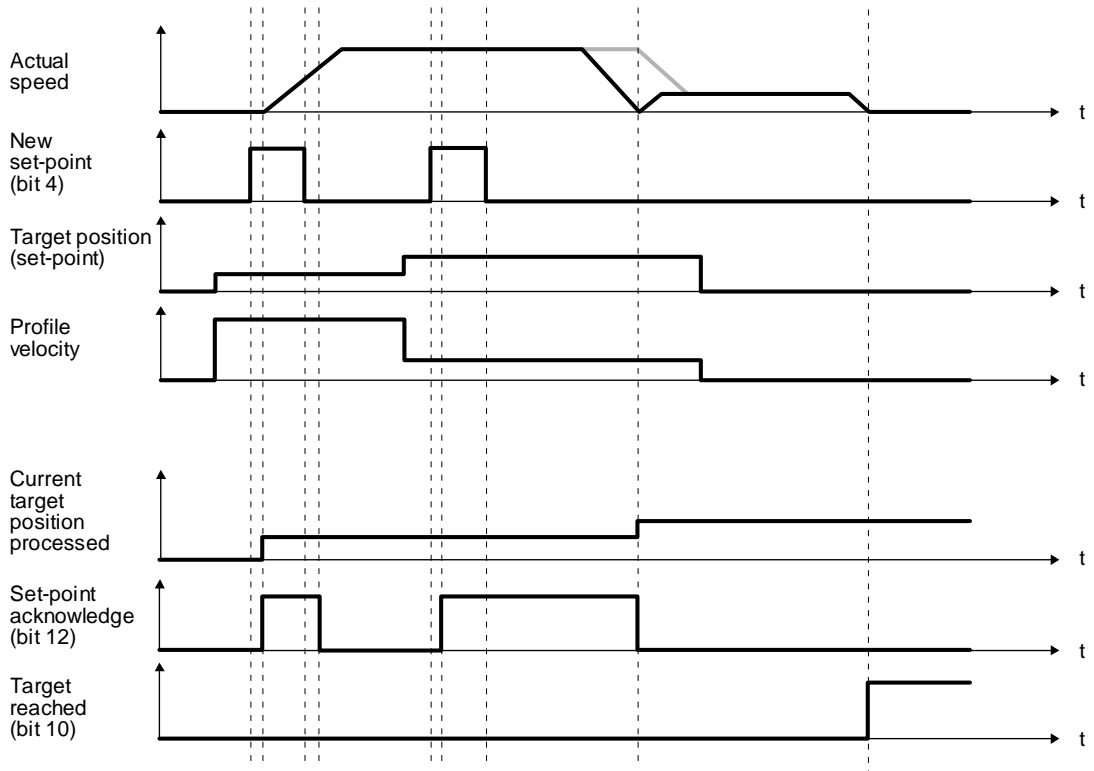

19.5.4.4 Profile velocity mode (pv)

The following shows the functions and related objects of the profile velocity mode (pv).

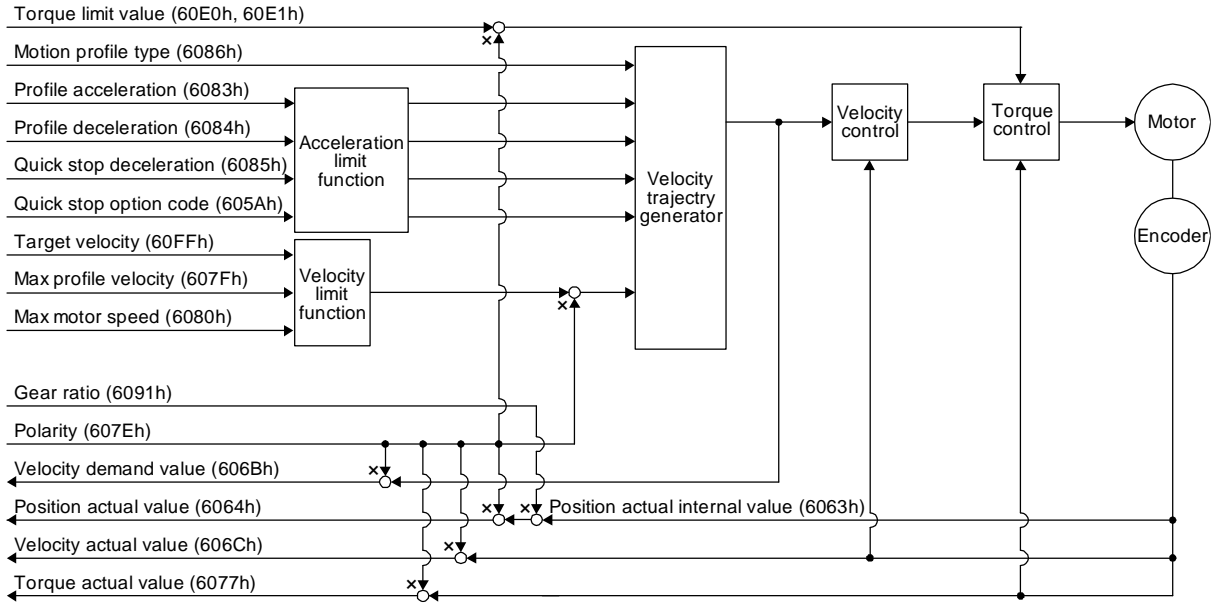

(1) Related object

Class ID	Ins ID	Attr ID	Access	Name	Data Type	Default	Description
64h	60FFh	0	Get/Set	Target velocity	DINT		Command speed Unit: Vel unit (0.01 r/min or 0.01 mm/s)
	607Fh	0	Get/Set	Max profile velocity	UDINT	2000000	maximum speed Unit: Vel unit (0.01 r/min or 0.01 mm/s)
	6080h	0	Get/Set	Max motor speed	UDINT		Servo motor maximum speed Unit: r/min
	6083h	0	Get/Set	Profile Acceleration	UDINT	0	Acceleration at start of movement to target position Unit: ms
	6084h	0	Get/Set	Profile deceleration	UDINT	0	Deceleration at arrival at target position Unit: ms
	6085h	0	Get/Set	Quick stop deceleration	UDINT	100	Deceleration at deceleration to a stop by Quick stop Unit: ms
	6086h	0	Get/Set	Motion profile type	INT	-1	Acceleration/deceleration type selection -1: S-pattern 0: Linear ramp (not supported) (Note) 1: Sin ² ramp (not supported) (Note) 2: Jerk-free ramp (not supported) (Note) 3: Jerk-limited ramp (not supported) (Note)
	605Ah	0	Get/Set	Quick stop option code	INT	2	Operation setting for Quick stop Refer to section 5.6.
	6063h	0	Get	Position actual internal value	DINT		Current position (Enc inc)
	6064h	0	Get	Position actual value	DINT		Current position (Pos units)

19. EtherNet/IP COMMUNICATION

Class ID	Ins ID	Attr ID	Access	Name	Data Type	Default	Description
64h	606Bh	0	Get	Velocity demand value	DINT		Speed command (after trajectory generation)
	606Ch	0	Get	Velocity actual value	DINT		Current speed Unit: Vel unit (0.01 r/min or 0.01 mm/s)
	6077h	0	Get	Torque actual value	DINT		Current torque Unit: 0.1% (rated torque of 100%)
	6092h	0	Get	Feed constant	USINT	2	Travel distance per revolution of an output shaft
		1	Get/Set	Feed	UDINT		Travel distance Refer to section 7.3.14 (4).
		2		Shaft revolutions			Number of servo motor shaft revolutions Refer to section 7.3.14 (4).
	60E0h	0	Get/Set	Positive torque limit value	UINT	10000	Torque limit value (forward) Unit: 0.1% (rated torque of 100%)
	60E1h	0	Get/Set	Negative torque limit value	UINT	10000	Torque limit value (reverse) Unit: 0.1% (rated torque of 100%)
	6091h	0	Get	Gear ratio	USINT	2	Gear ratio
		1	Get/Set	Motor revolutions	UDINT	1	Number of revolutions of the servo motor axis (numerator)
		2		Shaft revolutions		1	Number of revolutions of the drive axis (denominator)
	607Eh	0	Get/Set	Polarity	USINT	0	Polarity selection Bit 7: Position POL Bit 6: Velocity POL Bit 5: Torque POL Refer to section 5.10.
	606Dh	0	Get/Set	Velocity window	UINT	2000	Speed error threshold for judging Target reached Unit: 0.01 r/min or 0.01 mm/s
	606Eh	0	Get/Set	Velocity window time	UINT	0	Target reached judgment time Unit: ms
	606Fh	0	Get/Set	Velocity threshold	UINT	5000	Zero speed threshold for judging Speed Unit: 0.01 r/min or 0.01 mm/s
	6070h	0	Get/Set	Velocity threshold time	UINT	10	Speed judgment time Unit: ms
60A8h	0	Get/Set	SI unit position	UDINT	0	SI unit position The value is automatically set according to the setting of "Position data unit" of [Pr. PT01]. Refer to section 7.3.14 (5).	
60A9h	0	Get/Set	SI unit velocity	UDINT	0	SI unit velocity 0.01 r/min or 0.01 mm/s FB010300h (0.01 mm/s) FEB44700h (0.01 r/min)	

No
te. This is not supported by the driver.

19. EtherNet/IP COMMUNICATION

(2) Details on the OMS bit of Controlword (pv mode)

Bit	Symbol	Description
4	(reserved)	The value at reading is undefined. Set "0" at writing.
5	(reserved)	
6	(reserved)	
8	HALT	0: The servo motor is driven. 1: The servo motor is stopped according to Halt option code (Class ID: 64h, Ins ID: 605Dh, Attr ID: 0).
9	(reserved)	The value at reading is undefined. Set "0" at writing.

(3) Details on the OMS bit of Statusword (pv mode)

Bit	Symbol	Description
10	Target reached	0 (Halt (Bit 8) = 0): Target velocity not reached. 0 (Halt (Bit 8) = 1): Axis decelerates 1 (Halt (Bit 8) = 0): Target velocity reached. 1 (Halt (Bit 8) = 1): Velocity of axis is 0 Judgment condition for Target velocity reached If the error between Velocity actual value (Class ID: 64h, Ins ID: 606Ch, Attr ID: 0) and Target velocity (Class ID: 64h, Ins ID: 60FFh, Attr ID: 0) has stayed within Velocity window (Class ID: 64h, Ins ID: 606Dh, Attr ID: 0) for Velocity window time (Class ID: 64h, Ins ID: 606Eh, Attr ID: 0) or more, Target velocity reached is stored.
12	Speed	0: Speed is not equal 0 1: Speed is equal 0 Judgment condition for Speed is not equal 0 If the absolute value of Velocity actual value (Class ID: 64h, Ins ID: 606Ch, Attr ID: 0) has exceeded Velocity threshold (Class ID: 64h, Ins ID: 606Fh, Attr ID: 0) for Velocity threshold time (Class ID: 64h, Ins ID: 6070h, Attr ID: 0) or more, Speed is not equal 0 is stored.
13	Max slippage error	0: Maximum slippage not reached 1: Maximum slippage reached (not supported) (Note) Max slippage is a maximum slippage of the asynchronous servo motor.

Note. This is not supported by the driver.

(4) pv mode operation sequence

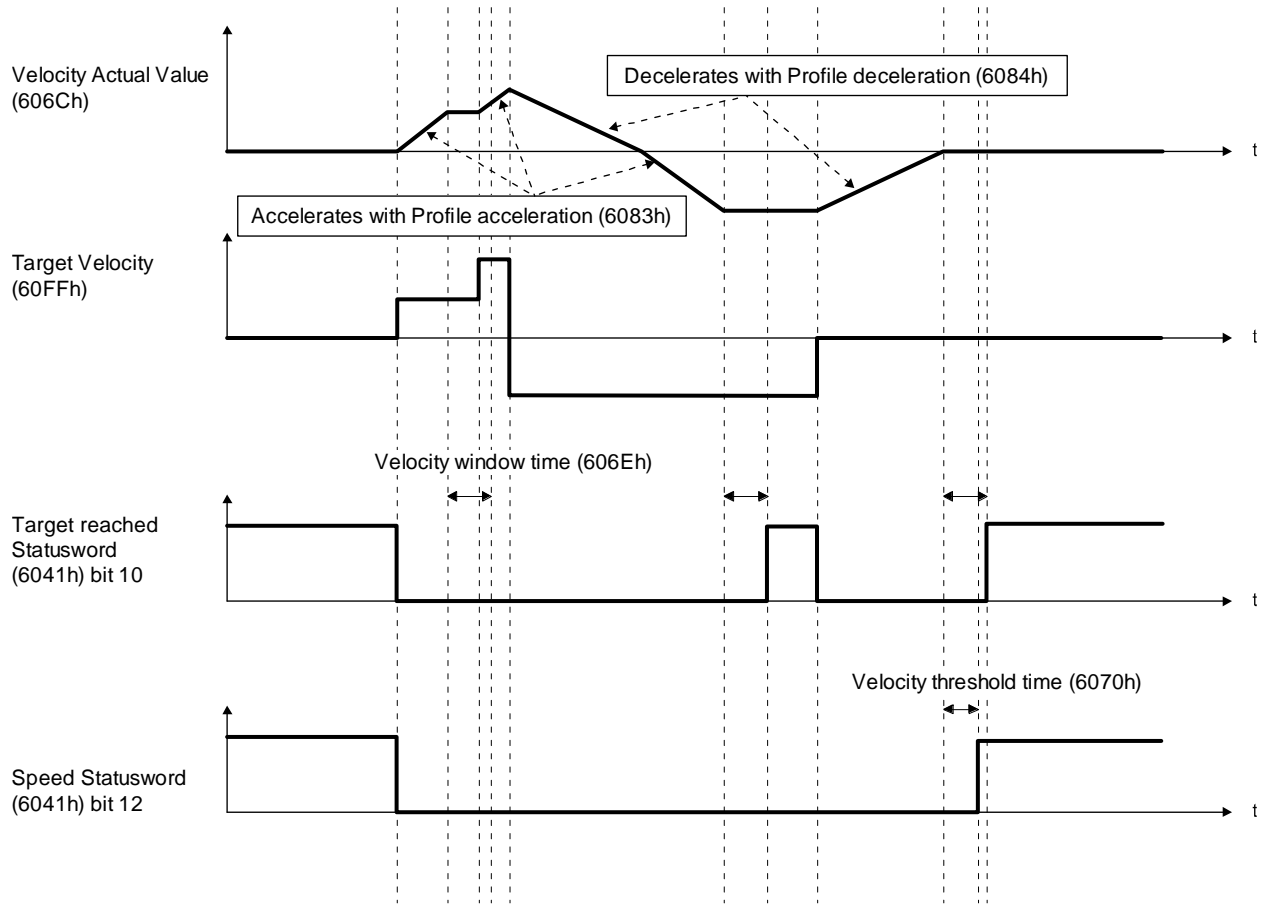

19.5.4.5 Profile torque mode (tq)

The following shows the functions and related objects of the profile torque mode (tq).

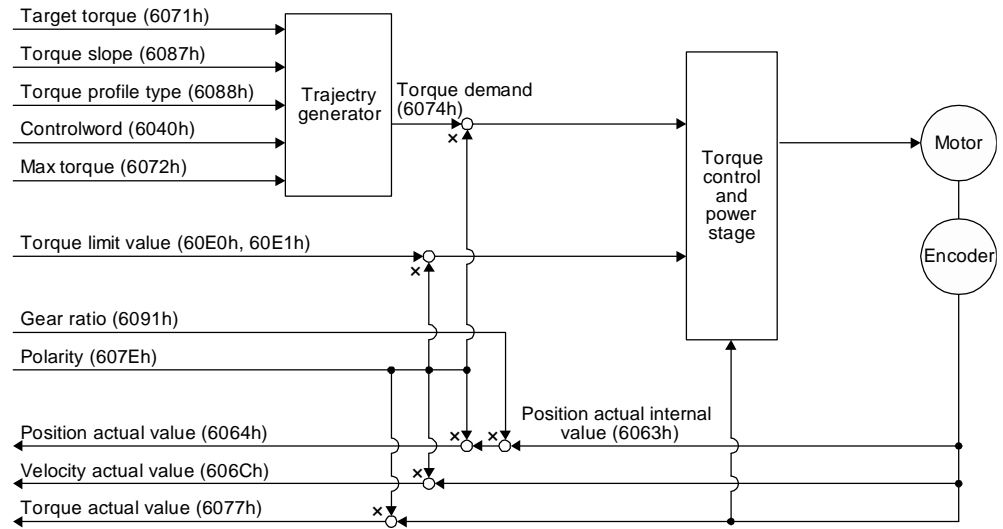

(1) Related object

Class ID	Ins ID	Attr ID	Access	Name	Data Type	Default	Description
64h	6040h	0	Get/Set	Controlword	UINT		Common control command
	6071h	0	Get/Set	Target torque	INT		Command torque Unit: 0.1% (rated torque of 100%)
	6072h	0	Get/Set	Max torque	UINT		Maximum torque Unit: 0.1% (rated torque of 100%)
	6074h	0	Get	Torque demand	INT		Command torque (after limit) Unit: 0.1% (rated torque of 100%)
	6087h	0	Get/Set	Torque slope	UDINT	0	Torque variation Unit: 0.1%/s (rated torque of 100%)
	6088h	0	Get/Set	Torque profile type	UDINT	0	Torque variation pattern 0000h: Linear ramp 0001h: Sin ² ramp (not supported) (Note) 0002h to 7FFFh: reserved 8000h to FFFFh: Manufacturer specific
	6063h	0	Get	Position actual internal value	DINT		Current position (Enc inc)
	6064h	0	Get	Position actual value	DINT		Current position (Pos units)
	606Ch	0	Get	Velocity actual value	DINT		Current speed Unit: Vel unit (0.01 r/min or 0.01 mm/s)
	6077h	0	Get	Torque actual value	DINT		Current torque Unit: 0.1% (rated torque of 100%)
	6092h	0	Get	Feed constant	USINT	2	Travel distance per revolution of an output shaft
		1	Get/Set	Feed	UDINT		Travel distance Refer to section 7.3.14 (4).
2		Shaft revolutions				Number of servo motor shaft revolutions Refer to section 7.3.14 (4).	

19. EtherNet/IP COMMUNICATION

Class ID	Ins ID	Attr ID	Access	Name	Data Type	Default	Description
64h	60E0h	0	Get/Set	Positive torque limit value	UINT	10000	Torque limit value (forward) Unit: 0.1% (rated torque of 100%)
	60E1h	0	Get/Set	Negative torque limit value	UINT	10000	Torque limit value (reverse) Unit: 0.1% (rated torque of 100%)
	6091h	0	Get	Gear ratio	USINT	2	Gear ratio
		1	Get/Set	Motor revolutions	UDINT	1	Number of revolutions of the servo motor axis (numerator)
		2		Shaft revolutions		1	Number of revolutions of the drive axis (denominator)
	607Eh	0	Get/Set	Polarity	USINT	0	Polarity selection Bit 7: Position POL Bit 6: Velocity POL Bit 5: Torque POL Refer to section 5.10.
	2D20h	0	Get/Set	Velocity limit value	DINT	5000	Speed limit value Unit: Vel unit (0.01 r/min or 0.01 mm/s)
	60A8h	0	Get/Set	SI unit position	UDINT	0	SI unit position The value is automatically set according to the setting of "Position data unit" of [Pr. PT01]. Refer to section 7.3.14 (5).
	60A9h	0	Get/Set	SI unit velocity	UDINT	0	SI unit velocity 0.01 r/min or 0.01 mm/s FB010300h (0.01 mm/s) FEB44700h (0.01 r/min)

Note. This is not supported by the driver.

(2) Details on the OMS bit of Controlword (tq mode)

Bit	Symbol	Description
4	(reserved)	The value at reading is undefined. Set "0" at writing.
5	(reserved)	
6	(reserved)	
8	HALT	0: The servo motor is driven. 1: The servo motor is stopped according to Halt option code (Class ID: 64h, Ins ID: 605Dh, Attr ID: 0).
9	(reserved)	The value at reading is undefined.

(3) Details on the OMS bit of Statusword (tq mode)

Bit	Symbol	Description
10	Target reached (not supported) (Note)	0 (Halt (Bit 8) = 0): Target torque not reached. 0 (Halt (Bit 8) = 1): Axis decelerates 1 (Halt (Bit 8) = 0): Target torque reached. 1 (Halt (Bit 8) = 1): Velocity of axis is 0 Judgment condition for Target torque reached If the error between Torque actual value (Class ID: 64h, Ins ID: 6077h, Attr ID: 0) and Target torque (Class ID: 64h, Ins ID: 6071h, Attr ID: 0) has stayed within Torque window for Torque window time or more, Target torque reached is stored.
12	(reserved)	The value at reading is undefined.
13	(reserved)	

Note. This is not supported by the driver.

19. EtherNet/IP COMMUNICATION

(4) tq mode operation sequence

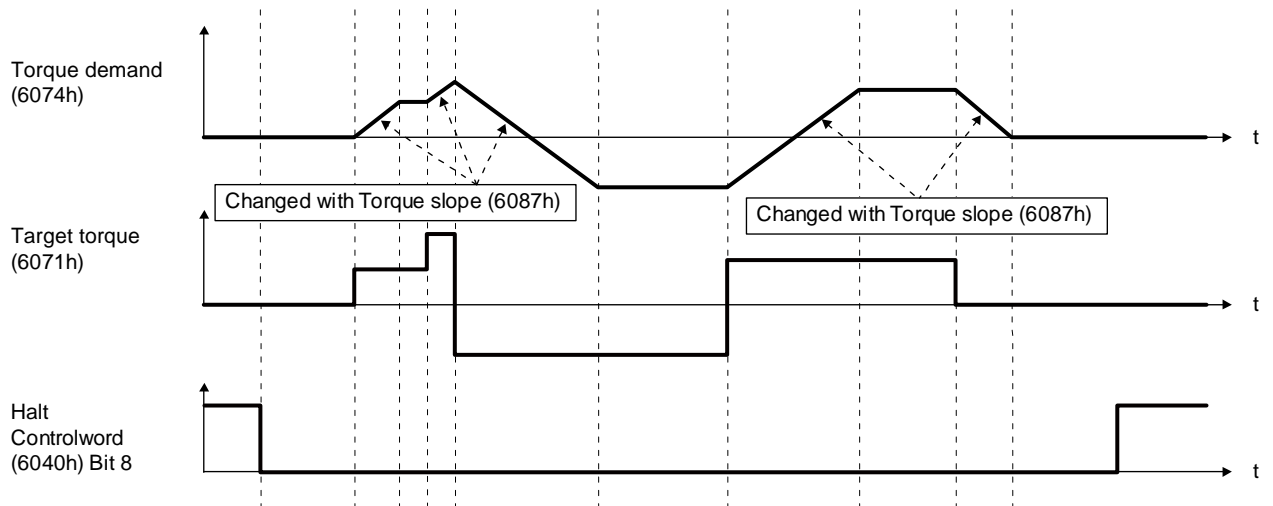

19.5.4.6 Homing mode (hm)

The following shows the function and related objects of the homing mode (hm).

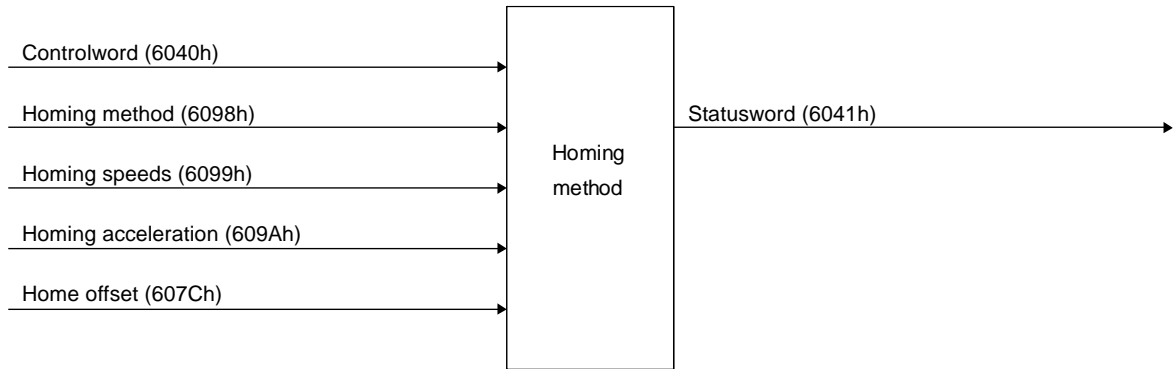

(1) Related object

Class ID	Ins ID	Attr ID	Access	Name	Data Type	Default	Description
64h	607Ch	0	Get	Home offset	DINT		The home position saved in EEP-ROM is stored at power-on. If a home position return is executed in the homing mode (hm), the home position will be updated. If [Pr. PA03 Absolute position detection system] is disabled, 0 is always stored.
	6098h	0	Get/Set	Homing Method	SINT	-1	Specify a home position return type. Refer to (4) in this section for supported home position return types.
	6099h	0	Get/Set	Homing Speeds	USINT	2	Number of entries of the home position return speed
		1	Get/Set	Speed during search for switch	UDINT	10000	Specify the travel speed until dog detection. Unit: Vel unit (0.01 r/min or 0.01 mm/s) Range: 0 to servo motor maximum speed
		2	Get/Set	Speed during search for zero	UDINT	1000	Specify the travel speed up to the home position after dog detection. (Note) Unit: Vel unit (0.01 r/min or 0.01 mm/s) Range: 0 to servo motor maximum speed
	609Ah	0	Get/Set	Homing acceleration	UDINT	0	Acceleration/deceleration time constant at home position return Unit: ms
	60E3h	0	Get	Supported Homing Method	USINT	39	Number of entries of the supported home position return type
		1	Get	1 st supported homing method	SINT	37	The home position return type that uses the current position as a home position is supported.
		to					
		39	Get	39 th supported homing method	SINT	-43	The dogless Z-phase reference home position return type (reverse rotation) is supported.

Note: In the homing mode (hm), the servo motor is brought to a sudden stop according to the deceleration time constant when the stroke end is detected. Set the home position return speed carefully.

19. EtherNet/IP COMMUNICATION

(2) Details on the OMS bit of Controlword (hm mode)

Bit	Symbol	Description
4	HOS	Homing operation start 0: Do not start homing procedure 1: Start or continue homing procedure
5	(reserved)	The value at reading is undefined. Set "0" at writing.
6	(reserved)	
8	HALT	Halt 0: Bit 4 enable 1: Stop axis according to halt option code (Class ID: 64h, Ins ID: 605Dh, Attr ID: 0)
9	(reserved)	The value at reading is undefined. Set "0" at writing.

(3) Details on the OMS bit of Statusword (hm mode)

POINT
<ul style="list-style-type: none"> ● When the mode is switched to the hm mode after home position return completion, Statusword is "Homing procedure is completed successfully" unless "0" is set in Bit 12. The following shows the conditions when "0" is set in Bit 12. For incremental system <ul style="list-style-type: none"> · At power-on · At communication shut-off by upper side reset · At home position return start · At home position erasure for absolute position detection system <ul style="list-style-type: none"> · At home position return start · At home position erasure ● To check the home position return status with Statusword, note the following. (when the communication cycle of 4 ms or less is set) <ul style="list-style-type: none"> · When the mode is switched to the hm mode, Modes of operation display is changed to 6 (hm) and Statusword changes at the same time. · The status change of Statusword may take 50 ms at a maximum after Bit 4 of Controlword (Homing operation start) is set. To obtain the status of Statusword without any fault, wait 50 ms or more. ● Before updating the position after a home position return completion, check that both Bit 12 and Bit 10 of Statusword are changed to "1" and then wait 8 ms. If 8 ms has not elapsed, the position information may not be updated correctly depending on the communication cycle setting.

Bit	Symbol	Description
10	Target reached	Refer to the following table for the definition.
12	Homing attained	
13	Homing error	

19. EtherNet/IP COMMUNICATION

The following shows the definition of Bit 10, Bit 12, and Bit 13 of Statusword in the hm mode.

Bit 13	Bit 12	Bit 10	Definition
0	0	0	Homing procedure is in progress
0	0	1	Homing procedure is interrupted or not started
0	1	0	Homing is attained, but target is not reached
0	1	1	Homing procedure is completed successfully
1	0	0	Homing error occurred, velocity is not 0
1	0	1	Homing error occurred, velocity is 0
1	1		reserved

(4) List of Homing method

POINT
<ul style="list-style-type: none"> ● In the following cases, make sure that the Z-phase has been passed through once before the home position return. Z-phase unpassed will trigger [AL. 90.5 Z-phase unpassed]. <ul style="list-style-type: none"> ▪ When using an incremental linear encoder in the linear servo motor control mode ▪ When using an incremental external encoder in the fully closed loop control mode ▪ For the use in the DD motor control mode ● To execute a home position return securely, start a home position return after moving the servo motor to the opposite stroke end with pv from the upper side and others. Whether the servo motor has reached the stroke end can be checked with Digital inputs (Class ID: 64h, Ins ID: 60FDh, Attr ID: 0). ● When changing the mode after the home position return completion, set 0 to the Target position (Class ID: 64h, Ins ID: 607Ah, Attr ID: 0) and change the control mode.

To specify the home position return type in the homing mode (hm), use Homing Method (Class ID: 64h, Ins ID: 6098h, Attr ID: 0). The _ driver supports Homing method in the following table.

Method No.	Home position return type	Rotation direction	Description
-1	Dog type (Rear end detection Z-phase reference)	Forward rotation	Deceleration starts at the front end of the proximity dog. After the rear end is passed, the position specified by the first Z-phase signal, or the position of the first Z-phase signal shifted by the specified home position shift distance is used as the home position.
-33		Reverse rotation	
-3	Data set type home position return		The current position is set as the home position.
-4	Stopper type (Stopper position reference)	Forward rotation	A workpiece is pressed against a mechanical stopper, and the position where it is stopped is set as the home position.
-36		Reverse rotation	
-2	Count type (Front end detection Z-phase reference)	Forward rotation	At the front end of the proximity dog, deceleration starts. After the front end is passed, the position specified by the first Z-phase signal after the set distance or the position of the Z-phase signal shifted by the set home position shift distance is set as a home position.
-34		Reverse rotation	
-6	Dog type (Rear end detection rear end reference)	Forward rotation	Deceleration starts from the front end of the proximity dog. After the rear end is passed, the position is shifted by the travel distance after proximity dog and the home position shift distance. The position after the shifts is set as the home position.
-38		Reverse rotation	
-7	Count type (Front end detection front end reference)	Forward rotation	Deceleration starts from the front end of the proximity dog. The position is shifted by the travel distance after proximity dog and the home position shift distance. The position after the shifts is set as the home position.
-39		Reverse rotation	
-8	Dog cradle type	Forward rotation	A position, which is specified by the first Z-phase signal after the front end of the proximity dog is detected, is set as the home position.
-40		Reverse rotation	
-9	Dog type last Z-phase reference	Forward rotation	After the front end of the proximity dog is detected, the position is shifted away from the proximity dog in the reverse direction. Then, the position specified by the first Z-phase signal or the position of the first Z-phase signal shifted by the home position shift distance is used as the home position.
-41		Reverse rotation	
-10	Dog type front end reference	Forward rotation	Starting from the front end of the proximity dog, the position is shifted by the travel distance after proximity dog and the home position shift distance. The position after the shifts is set as the home position.
-42		Reverse rotation	

19. EtherNet/IP COMMUNICATION

Method No.	Home position return type	Rotation direction	Description
-11	Dogless Z-phase reference	Forward rotation	The position specified by the first Z-phase signal, or the position of the first Z-phase signal shifted by the home position shift distance is used as the home position.
-43		Reverse rotation	
3	Homing on positive home switch and index pulse	Forward rotation	Same as the dog type last Z-phase reference home position return. Note that if the stroke end is detected during home position return, [AL. 90 Home position return incomplete warning] occurs.
4	Homing on positive home switch and index pulse	Forward rotation	Same as the dog cradle type home position return. Note that if the stroke end is detected during home position return, [AL. 90 Home position return incomplete warning] occurs.
5	Homing on negative home switch and index pulse	Reverse rotation	Same as the dog type last Z-phase reference home position return. Note that if the stroke end is detected during home position return, [AL. 90 Home position return incomplete warning] occurs.
6	Homing on negative home switch and index pulse	Reverse rotation	Same as the dog cradle type home position return. Note that if the stroke end is detected during home position return, [AL. 90 Home position return incomplete warning] occurs.
7	Homing on home switch and index pulse	Forward rotation	Same as the dog type last Z-phase reference home position return.
8	Homing on home switch and index pulse	Forward rotation	Same as the dog cradle type home position return.
11	Homing on home switch and index pulse	Reverse rotation	Same as the dog type last Z-phase reference home position return.
12	Homing on home switch and index pulse	Reverse rotation	Same as the dog cradle type home position return.
19	Homing without index pulse	Forward rotation	Same as the dog type front end reference home position return. Note that if the stroke end is detected during home position return, [AL. 90 Home position return incomplete warning] occurs.
20	Homing without index pulse	Forward rotation	Although this type is the same as the dog cradle type home position return, the stop position is not on the Z-phase. Starting from the front end of the dog, the position is shifted by the travel distance after proximity dog and the home position shift distance. The position after the shifts is set as the home position. If the stroke end is detected during home position return, [AL. 90 Home position return incomplete warning] occurs.
21	Homing without index pulse	Reverse rotation	Same as the dog type front end reference home position return. Note that if the stroke end is detected during home position return, [AL. 90 Home position return incomplete warning] occurs.
22	Homing without index pulse	Reverse rotation	Although this type is the same as the dog cradle type home position return, the stop position is not on the Z-phase. Starting from the front end of the dog, the position is shifted by the travel distance after proximity dog and the home position shift distance. The position after the shifts is set as the home position. If the stroke end is detected during home position return, [AL. 90 Home position return incomplete warning] occurs.
23	Homing without index pulse	Forward rotation	Same as the dog type front end reference home position return.
24	Homing without index pulse	Forward rotation	Although this type is the same as the dog cradle type home position return, the stop position is not on the Z-phase. Starting from the front end of the dog, the position is shifted by the travel distance after proximity dog and the home position shift distance. The position after the shifts is set as the home position.
27	Homing without index pulse	Reverse rotation	Same as the dog type front end reference home position return.
28	Homing without index pulse	Reverse rotation	Although this type is the same as the dog cradle type home position return, the stop position is not on the Z-phase. Starting from the front end of the dog, the position is shifted by the travel distance after proximity dog and the home position shift distance. The position after the shifts is set as the home position.
33	Homing on index pulse	Reverse rotation	Although this type is the same as the dogless Z-phase reference home position return, the creep speed is applied as the movement start speed.
34	Homing on index pulse	Forward rotation	Although this type is the same as the dogless Z-phase reference home position return, the creep speed is applied as the movement start speed.

Method No.	Home position return type	Rotation direction	Description
35	Homing on current position		The current position is set as the home position. This type can be executed not in the Operation enabled state.
37	Homing on current position		The current position is set as the home position. This type can be executed not in the Operation enabled state.

(5) CiA 402-type homing method

(a) Home position return type in CiA 402 type

The following shows the CiA 402-type home position return.

1) Method 3 and 4: Homing on positive home switch and index pulse

These home position return types use the front end of the proximity dog as reference and set the Z-phase right before and right after the dog as a home position.

Method 3 has the operation of the dog type last Z-phase reference home position return, and

Method 4 has the operation of the dog cradle type home position return at a forward rotation start.

However, if the stroke end is detected during home position return, [AL. 90] occurs.

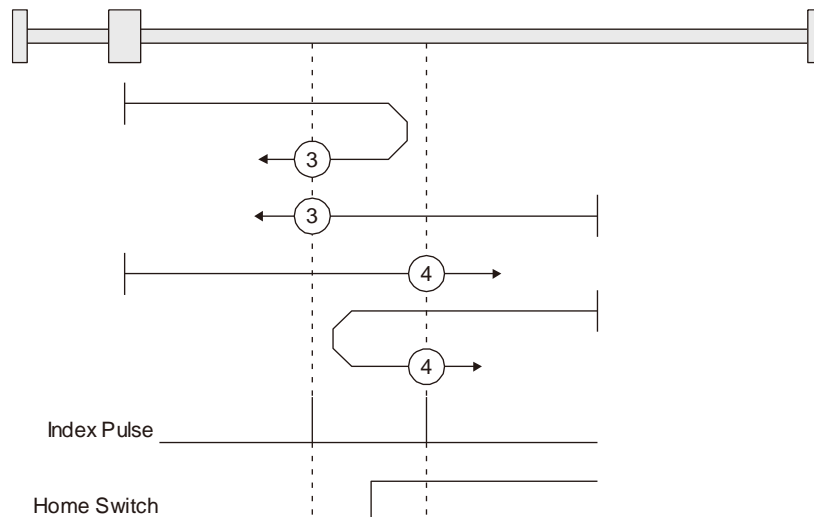

2) Method 5 and 6: Homing on negative home switch and index pulse

These home position return types use the front end of the proximity dog as reference and set the Z-phase right before and right after the dog as a home position. Method 5 and 6 differ from

Method 3 and Method 4 in the starting direction: the starting direction of Method 5 and 6 is the reversed direction.

3) Method 7, 8, 11, 12: Homing on home switch and index pulse

These types include the operation at stroke end detection in addition to the operation of Method 3 to Method 6. Thus, the home position is the same as that of Method 3 to Method 6. Method 7 has the operation of the dog type last Z-phase reference home position return. Method 8 has the operation of the dog cradle type home position return at a forward rotation start. Method 11 and 12 differ from Method 7 and Method 8 only in the starting direction: the starting direction of Method 11 and 12 is the reversed direction.

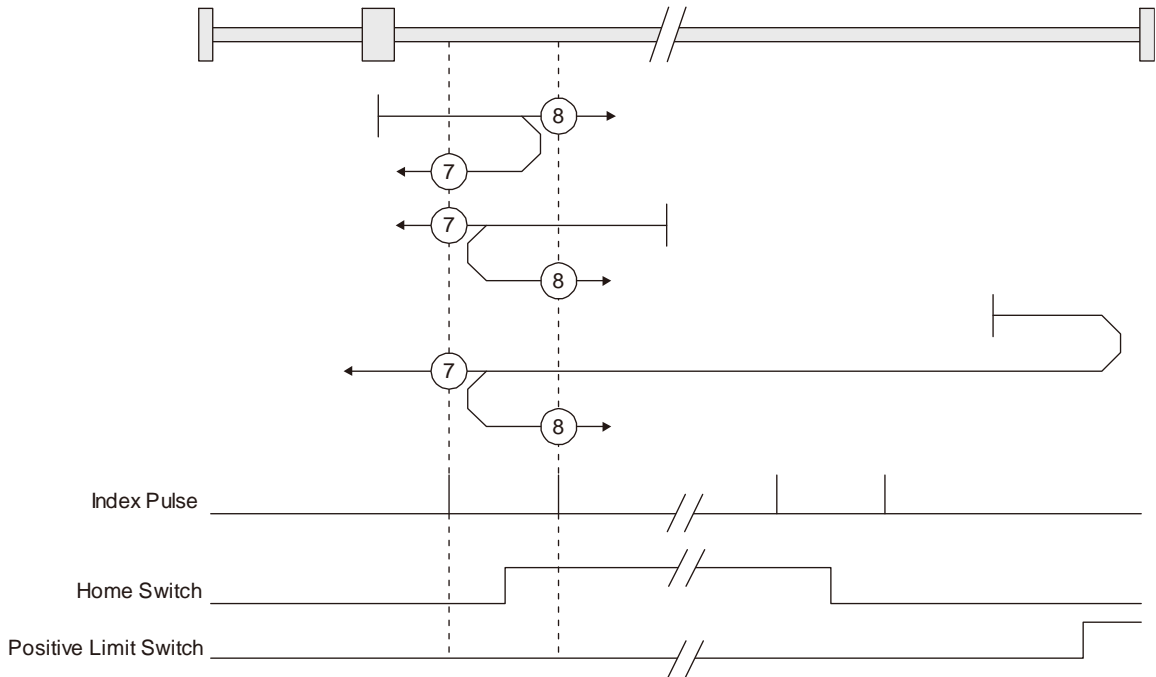

4) Method 17 to 30: Homing without index pulse

Method 17 to 30 have the operation of Method 1 to Method 14; however, these types set the home position not on the Z-phase but on the dog. Method 17 to 30 have the operation of Method 1 to Method 14; however, these types set the home position not on the Z-phase but on the dog. The following figure shows the operation of the home position return type of Method 19 and Method 20. Method 19 and Method 20 have the operation of Method 3 and Method 4; however, these types set the home position not on the Z-phase but on the dog. Method 19 has the operation of the dog type front end reference home position return. Method 20 has the operation of the dog cradle type home position return; however, the stop position is not on the Z-phase but on the dog.

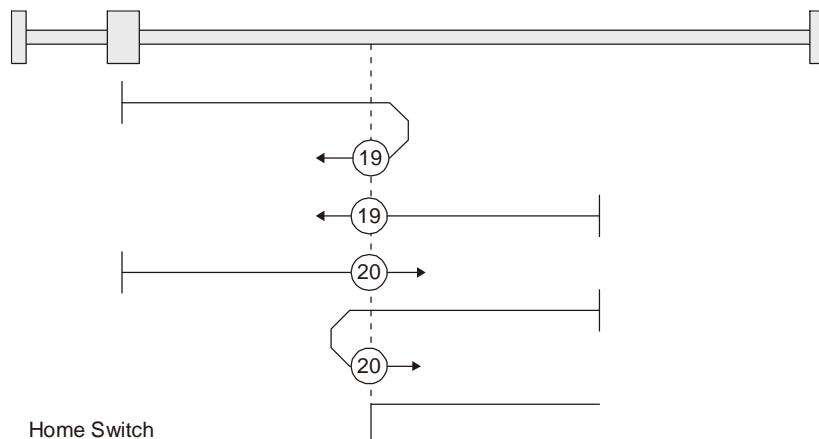

5) Method 33 and 34: Homing on index pulse

These home position return types set the Z-phase detected first as a home position. The operation is the same as that of the dogless Z-phase reference home position return except that the creep speed is applied at the start.

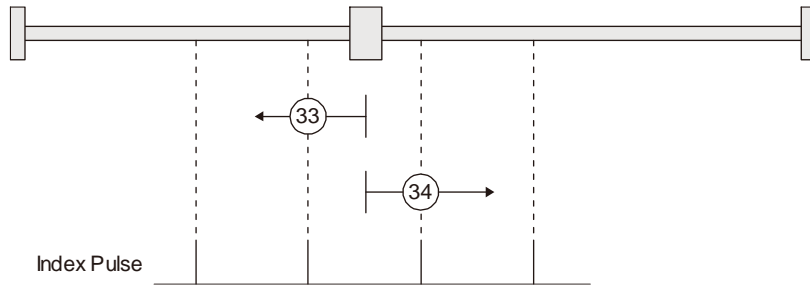

6) Method 35 and 37: Homing on current position

These home position return types set the current position as a home position. The operation is the same as that of the data set type home position return; however, these types can be executed even during servo-off.

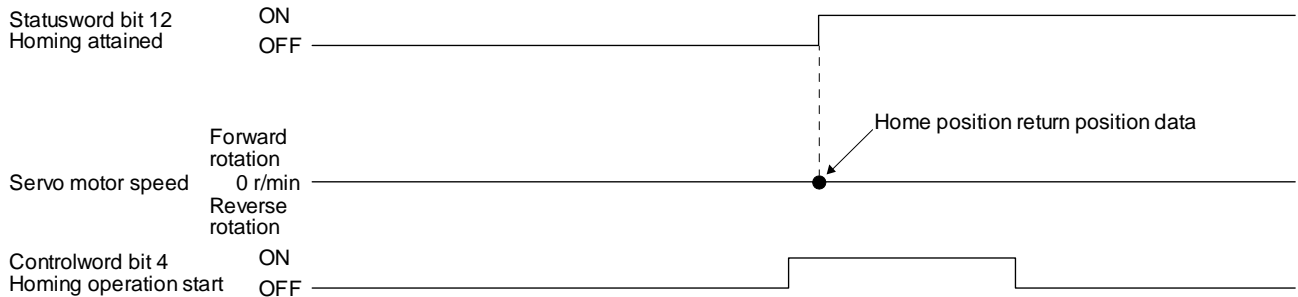

(b) Operation example of the CiA 402-type Homing method

The following shows an operation example of the home position return in the CiA 402-type Homing method.

1) Method 3 (Homing on positive home switch and index pulse) and Method 5 (Homing on negative home switch and index pulse)

The following figure shows the operation of Homing method 3. The operation direction of Homing method 5 is opposite to that of Homing method 3.

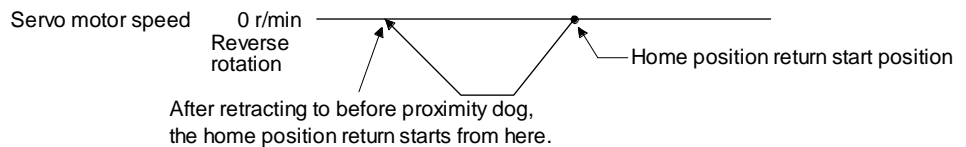
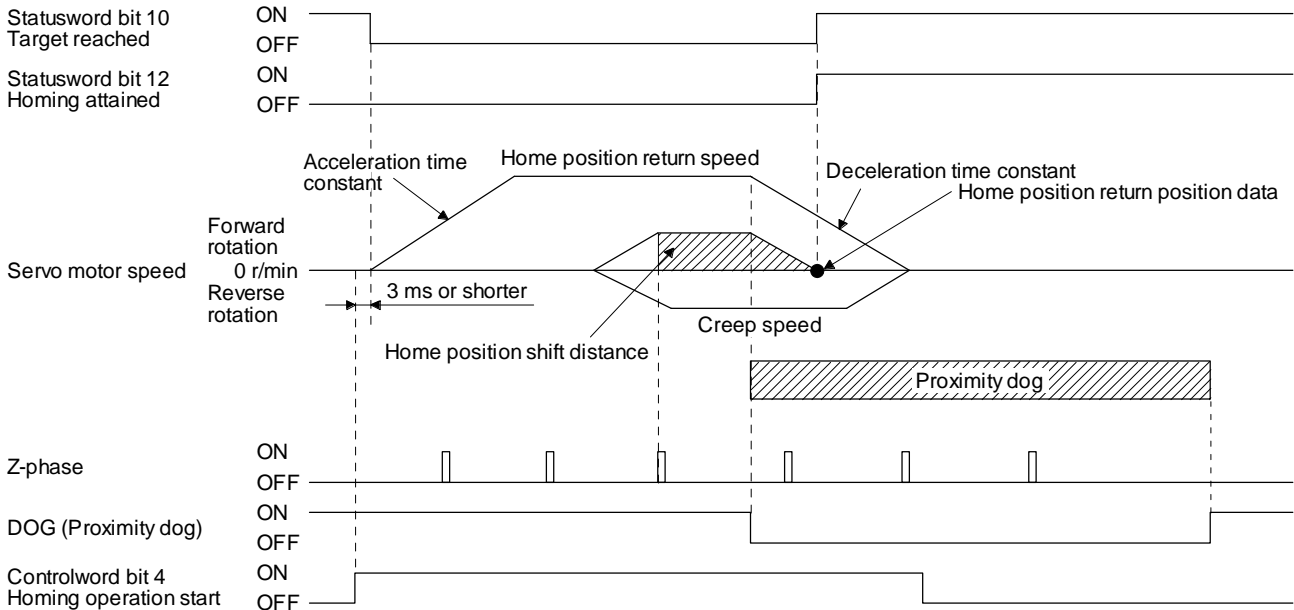

When a home position return is started from the proximity dog

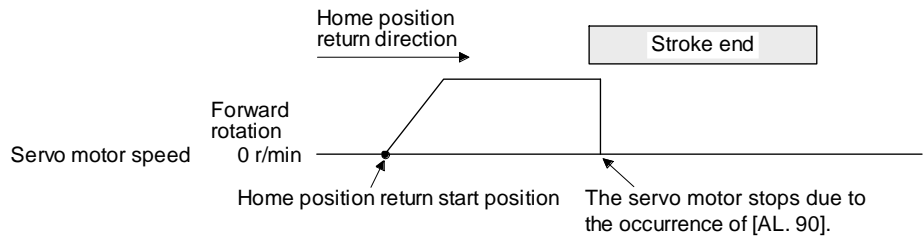

When the stroke end is detected

- 2) Method 4 (Homing on positive home switch and index pulse) and Method 6 (Homing on negative home switch and index pulse)

The following figure shows the operation of Homing method 4. The operation direction of Homing method 6 is opposite to that of Homing method 4.

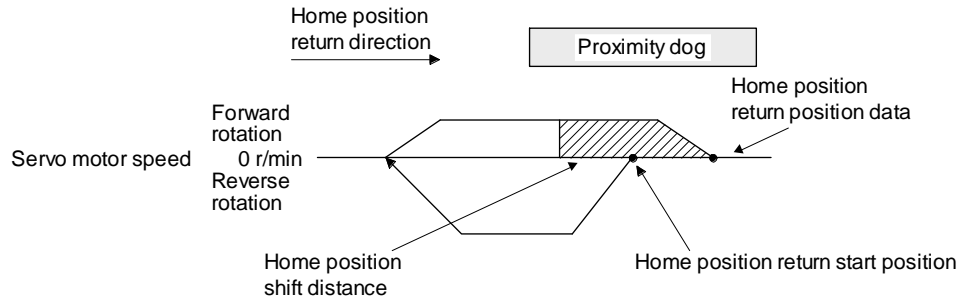
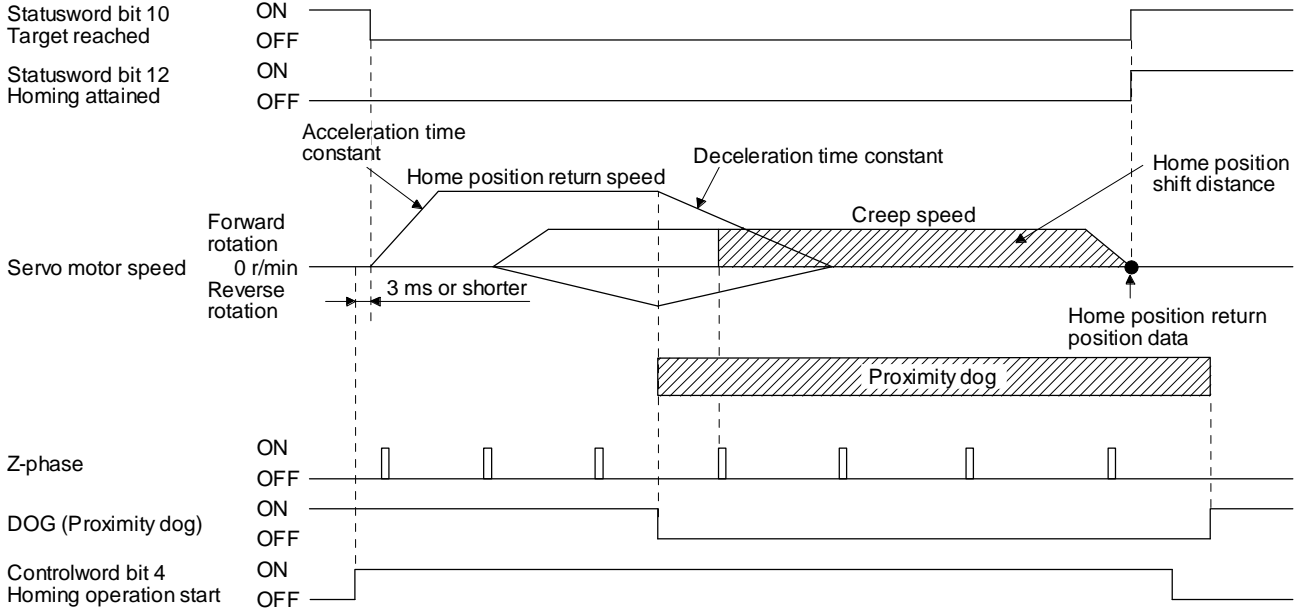

When a home position return is started from the proximity dog

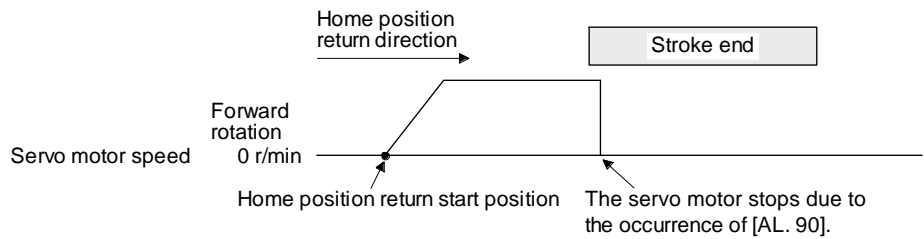

When the stroke end is detected

3) Method 7 and Method 11 (Homing on home switch and index pulse)

The following figure shows the operation of Homing method 7. The operation direction of Homing method 11 is opposite to that of Homing method 7.

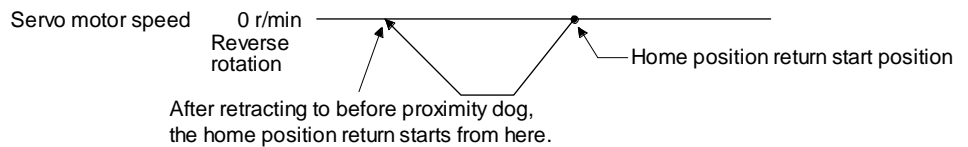
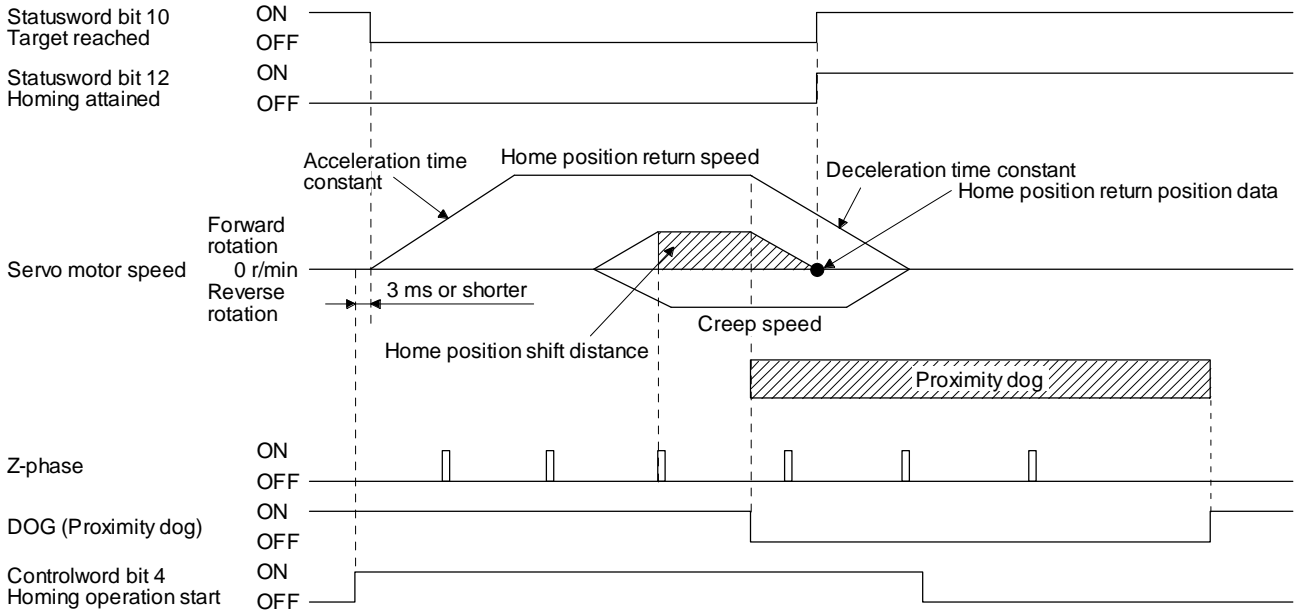

When a home position return is started from the proximity dog

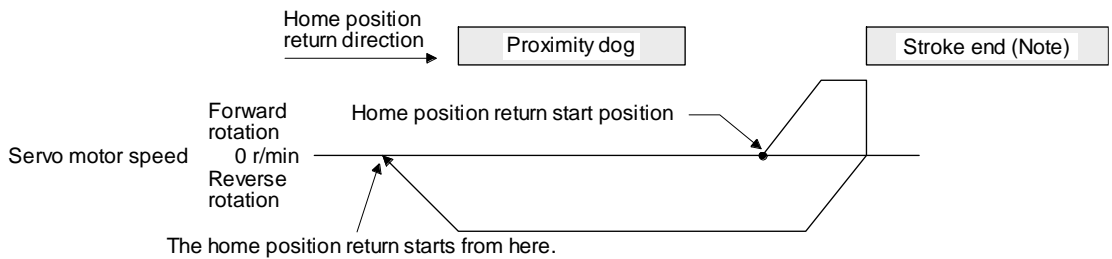

No te.	The software limit cannot be used with these functions.
--------	---

When the movement is returned at the stroke end

4) Method 8 and Method 12 (Homing on home switch and index pulse)

The following figure shows the operation of Homing method 8. The operation direction of Homing method 12 is opposite to that of Homing method 8.

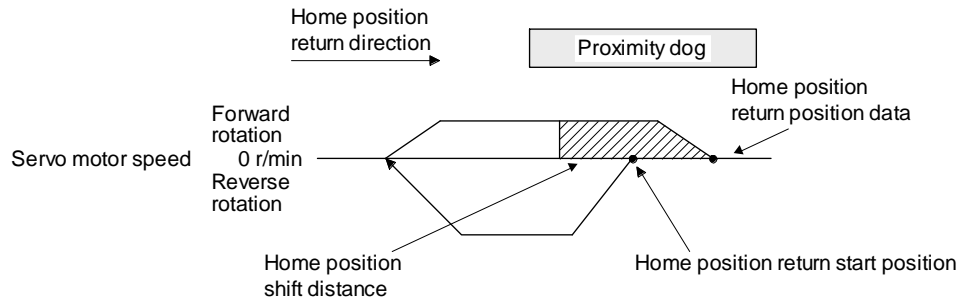
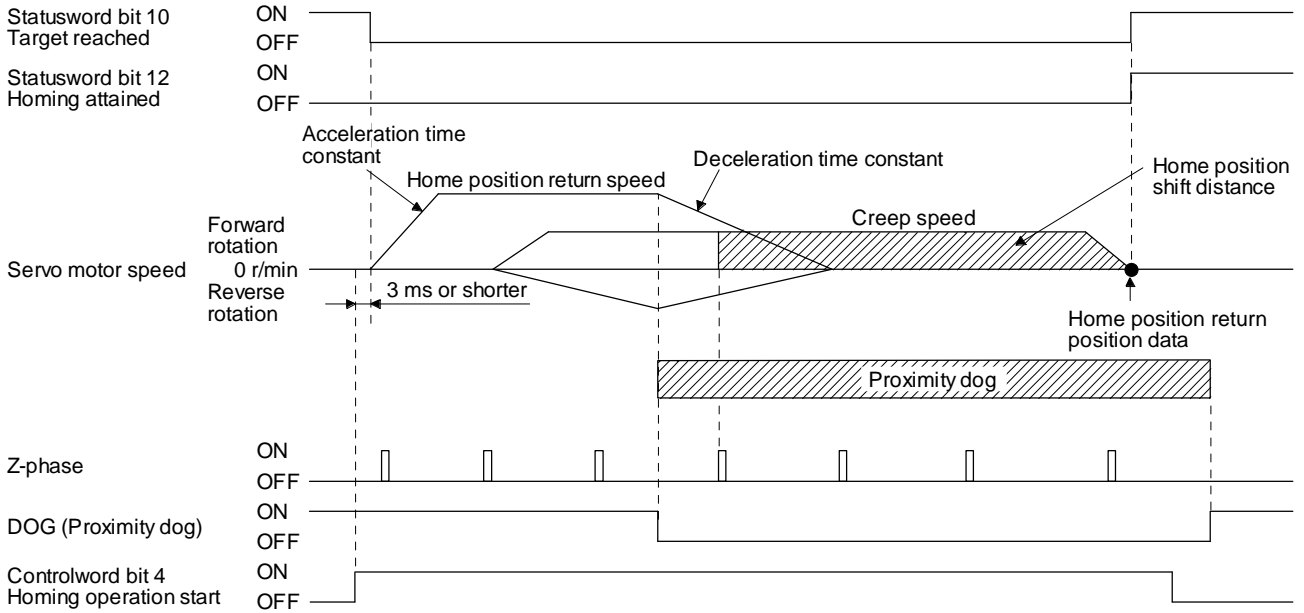

When a home position return is started from the proximity dog

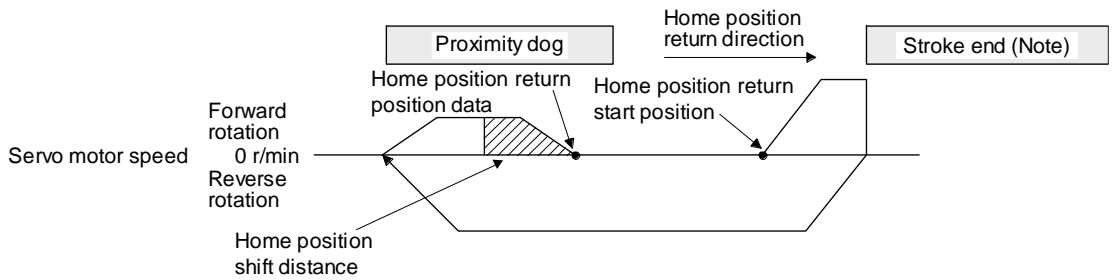

No te.	The software limit cannot be used with these functions.
-----------	---

When the movement is returned at the stroke end

5) Method 19 and Method 21 (Homing without index pulse)

The following figure shows the operation of Homing method 19. The operation direction of Homing method 21 is opposite to that of Homing method 19.

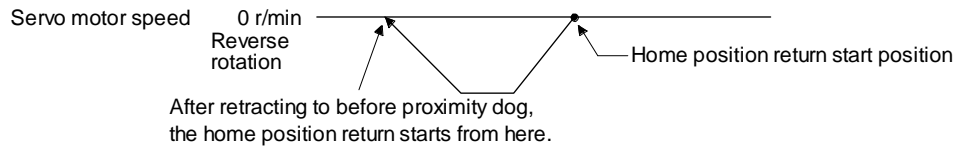
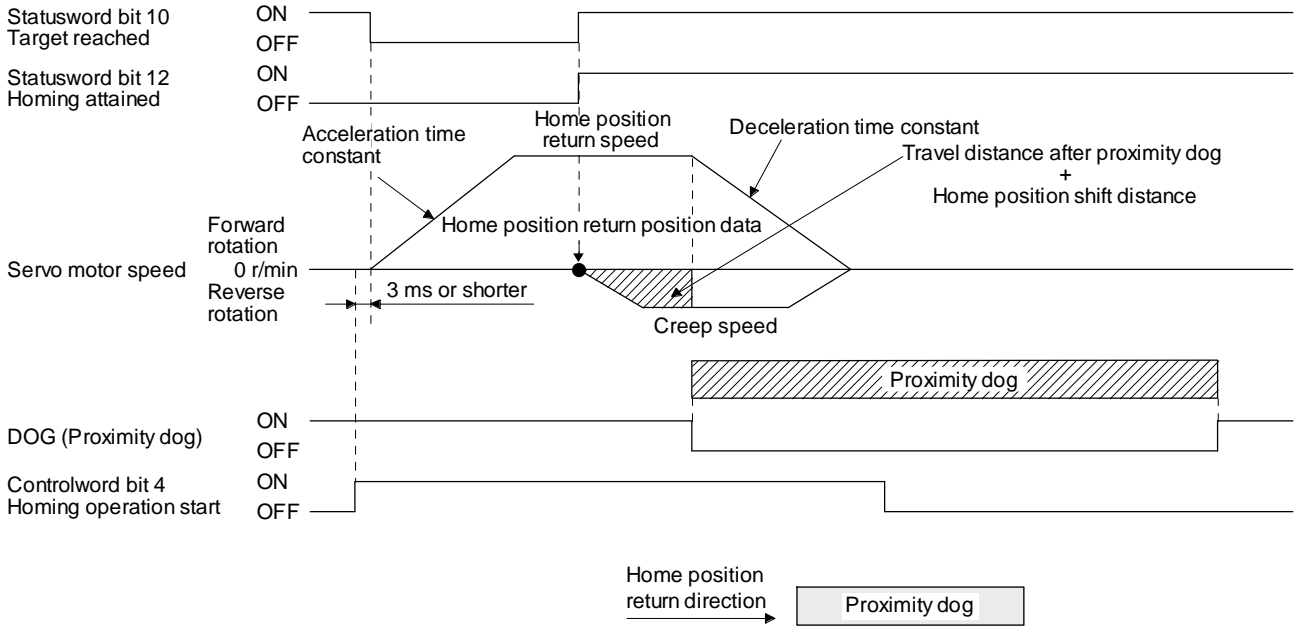

When a home position return is started from the proximity dog

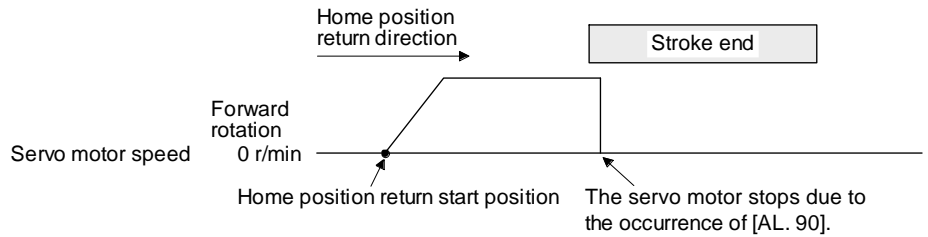

When the stroke end is detected

6) Method 20 and Method 22 (Homing without index pulse)

The following figure shows the operation of Homing method 20. The operation direction of Homing method 22 is opposite to that of Homing method 20.

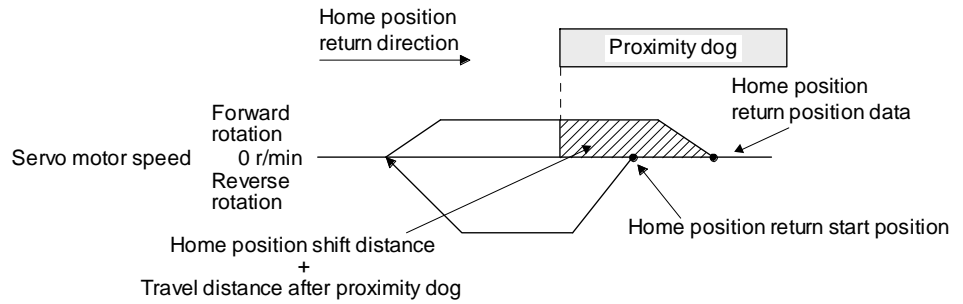
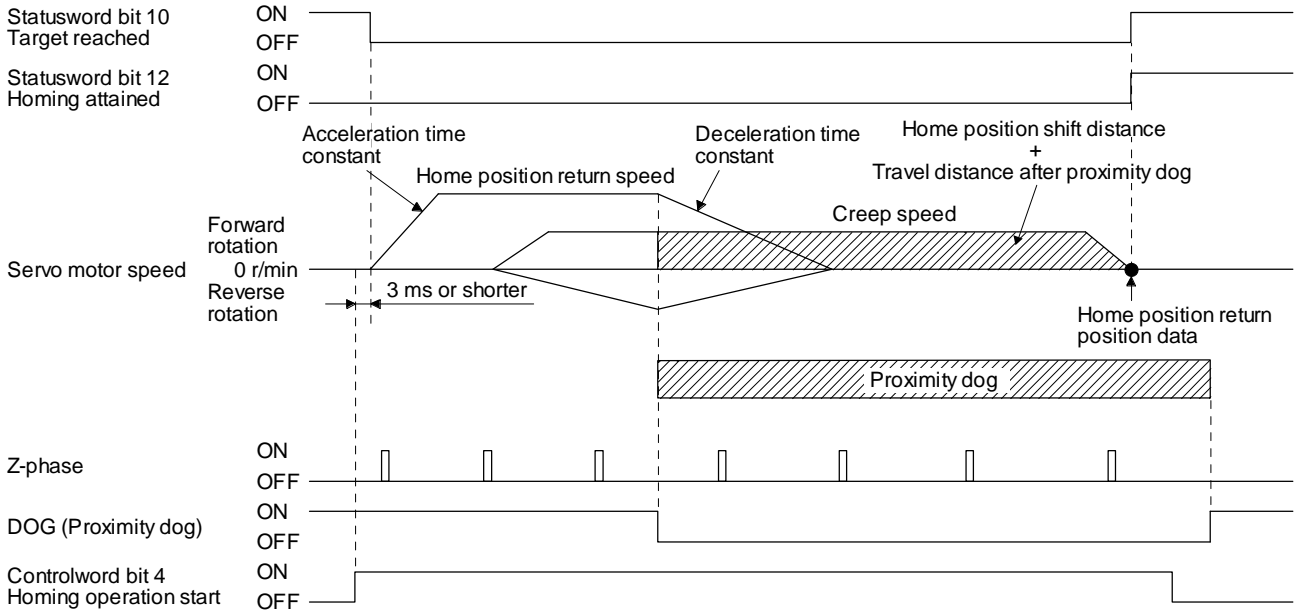

When a home position return is started from the proximity dog

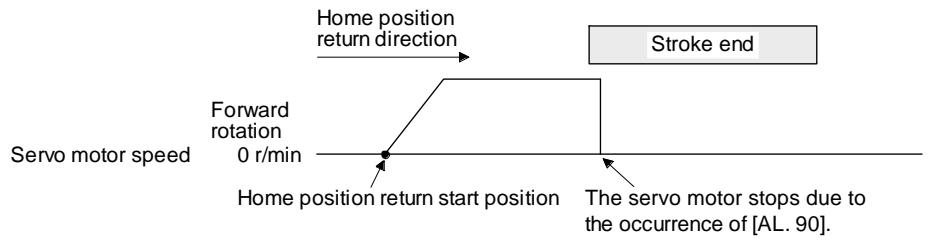

When the stroke end is detected

7) Method 23 and Method 27 (Homing without index pulse)

The following figure shows the operation of Homing method 23. The operation direction of Homing method 27 is opposite to that of Homing method 23.

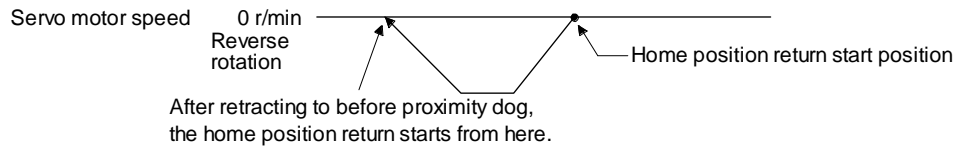
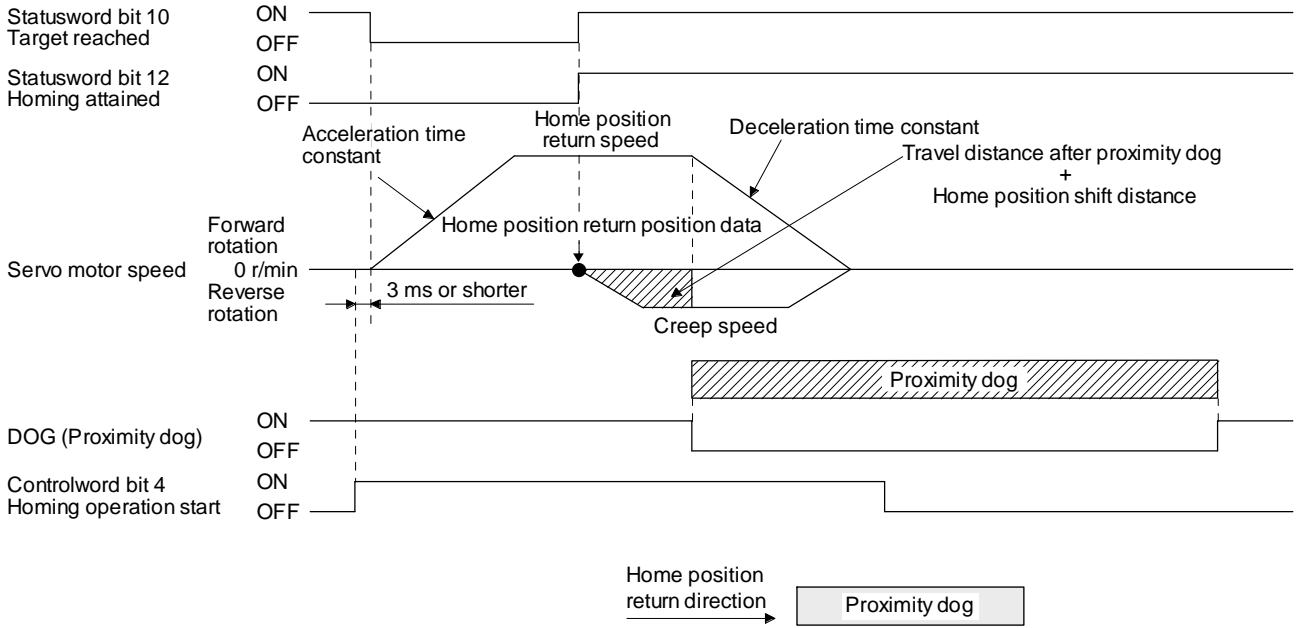

When a home position return is started from the proximity dog

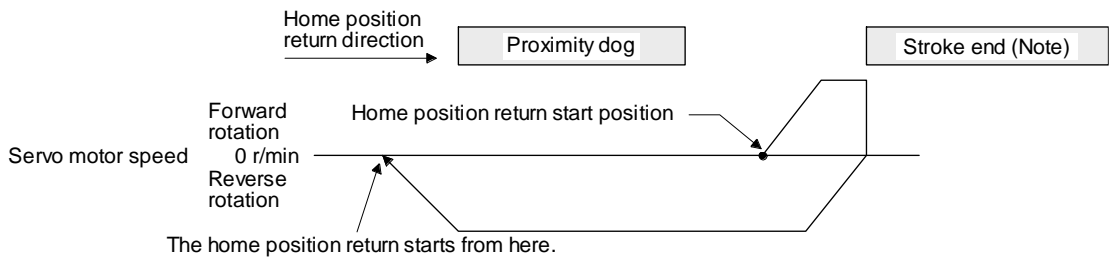

No te.	The software limit cannot be used with these functions.
--------	---

When the movement is returned at the stroke end

8) Method 24 and Method 28 (Homing without index pulse)

The following figure shows the operation of Homing method 24. The operation direction of Homing method 28 is opposite to that of Homing method 24.

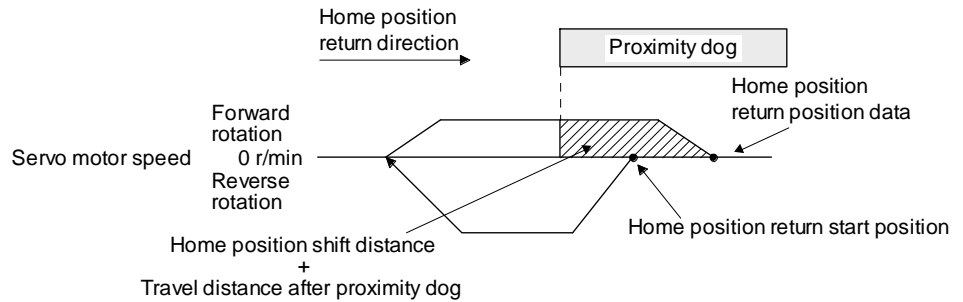
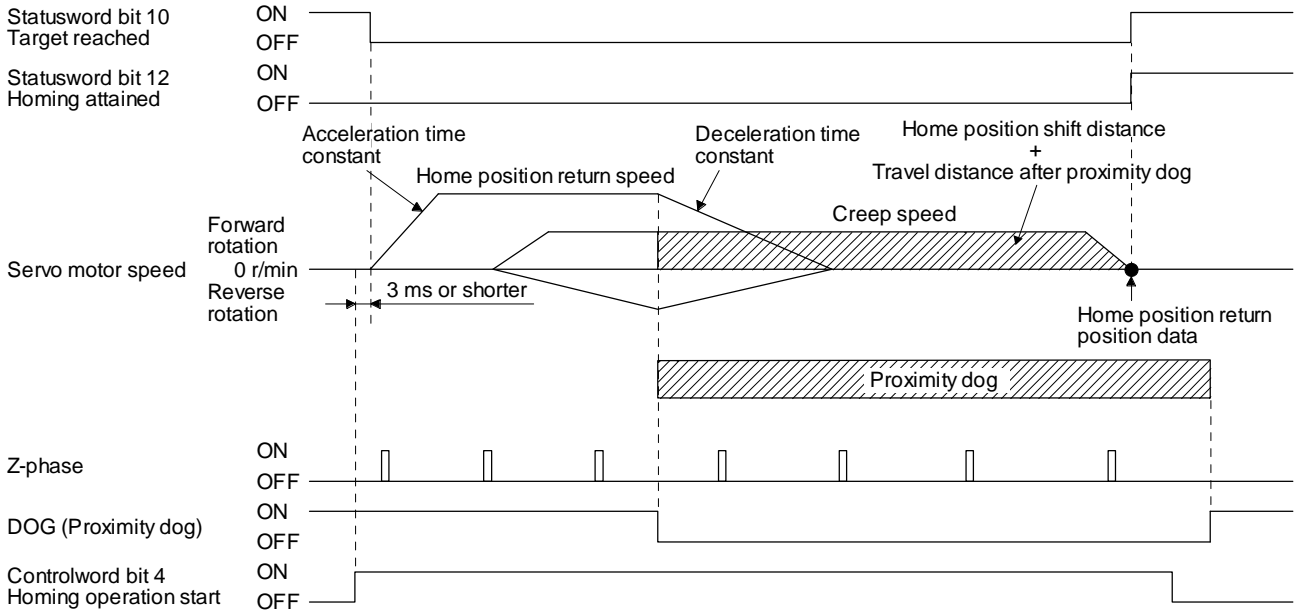

When a home position return is started from the proximity dog

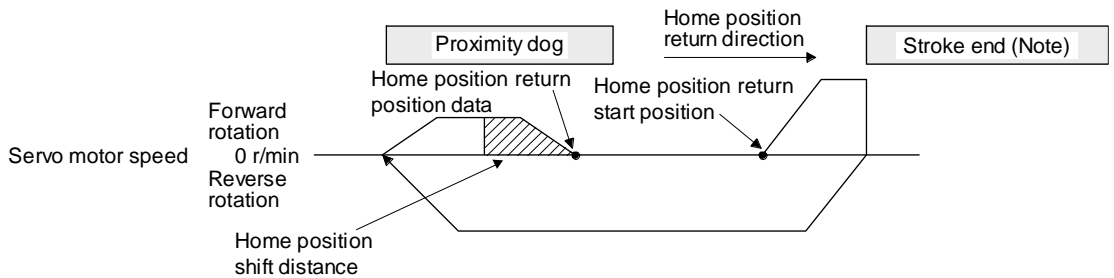

No te.	The software limit cannot be used with these functions.
--------	---

When the movement is returned at the stroke end

9) Method 33 and Method 34 (Homing on index pulse)

The following figure shows the operation of Homing method 34. The operation direction of Homing method 33 is opposite to that of Homing method 34.

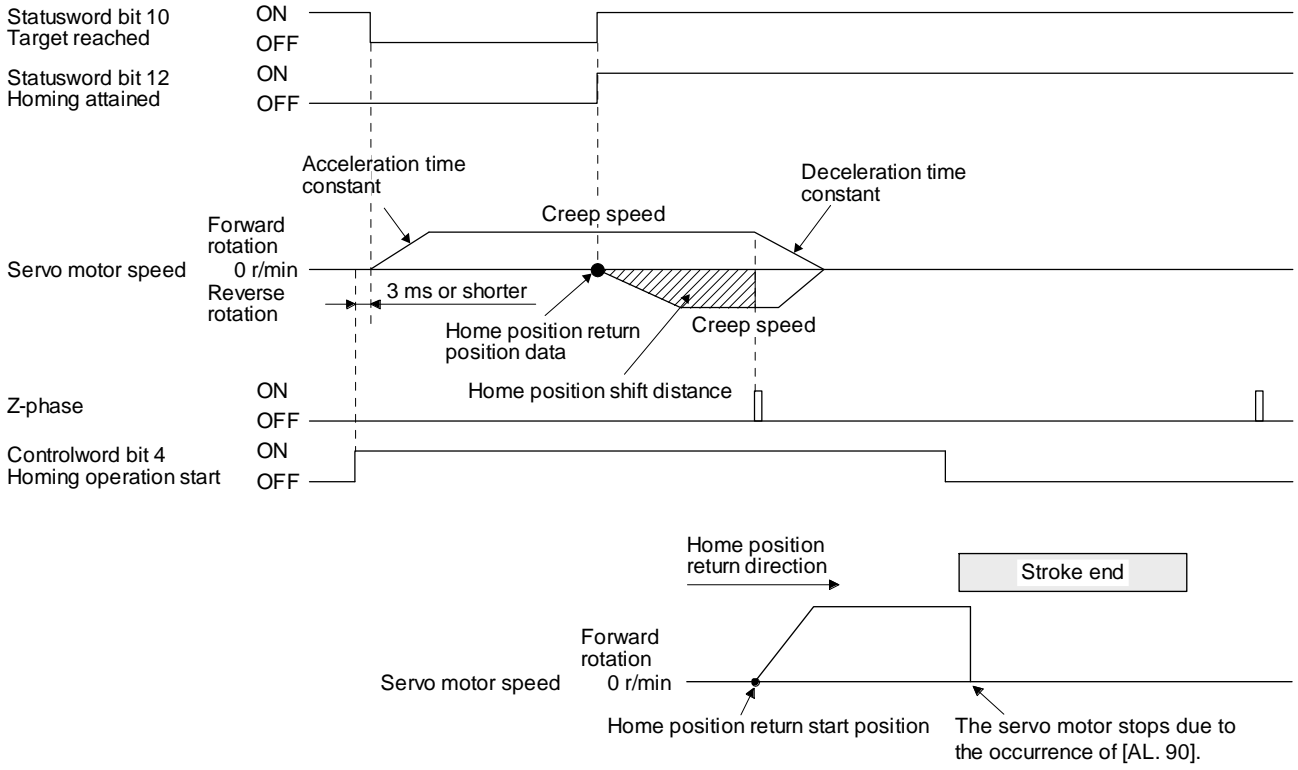

When the stroke end is detected

10) Method 35 and Method 37 (Homing on current position)

The following figure shows the operation of Homing method 35 and Homing method 37. These methods can be performed in the servo-off status.

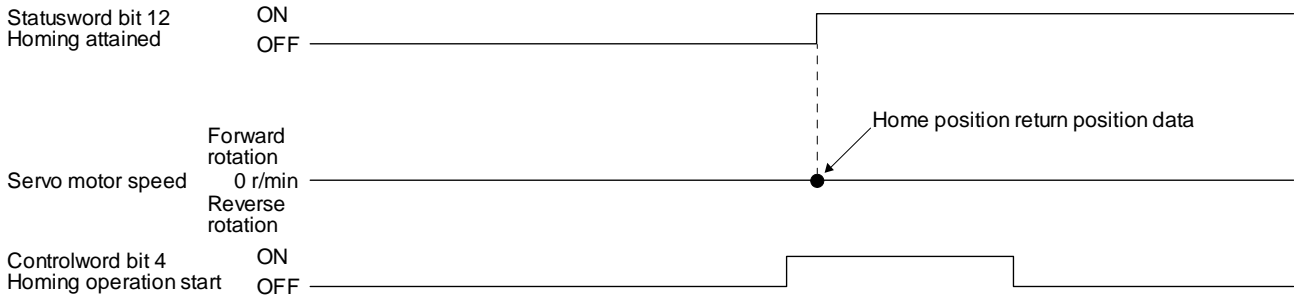

(6) Operation example of Manufacturer-specific Homing method

The following shows an operation example of the Manufacturer-specific home return.

(a) Method -1 and -33 (Dog type home position return)

The following figure shows the operation of Homing method -1. The operation direction of Homing method -33 is opposite to that of Homing method -1.

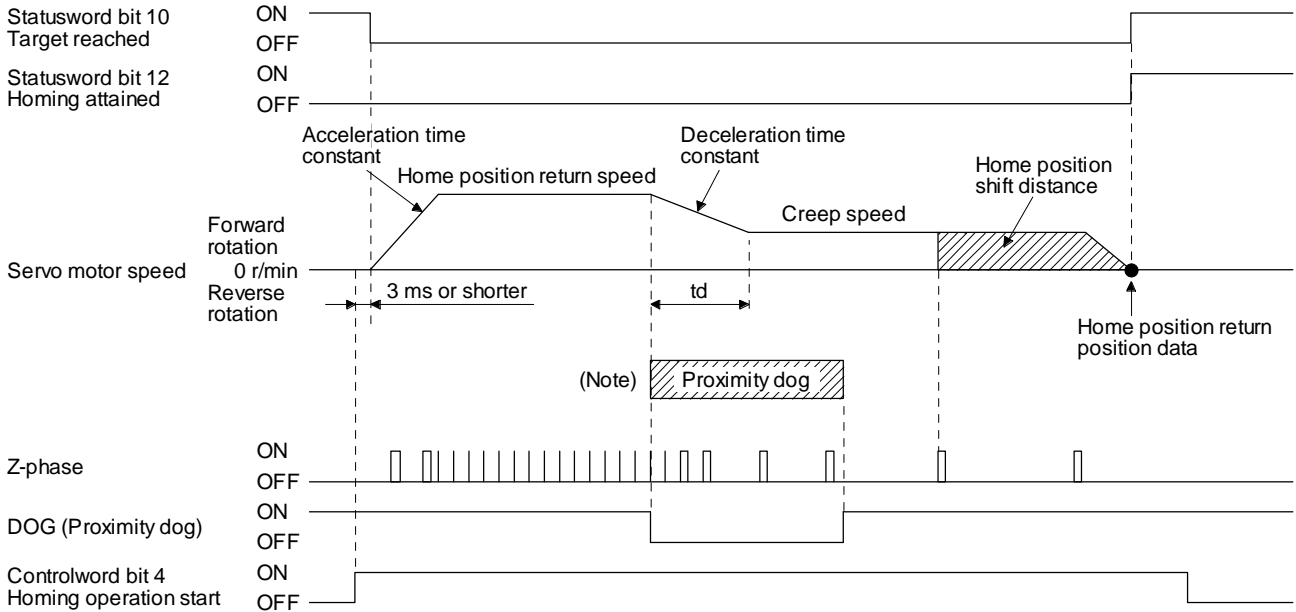

No te.	After the front end of the proximity dog is detected, if the distance after proximity dog is traveled without reaching the creep speed, [AL. 90] occurs. Set the travel distance after proximity dog enough for deceleration from the home position return speed to the creep speed.
--------	--

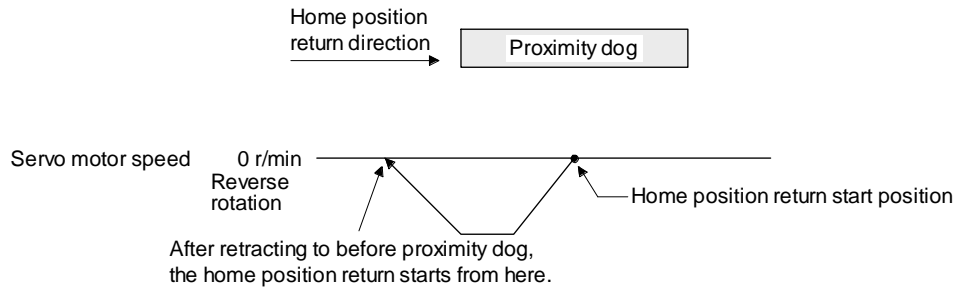

When a home position return is started from the proximity dog

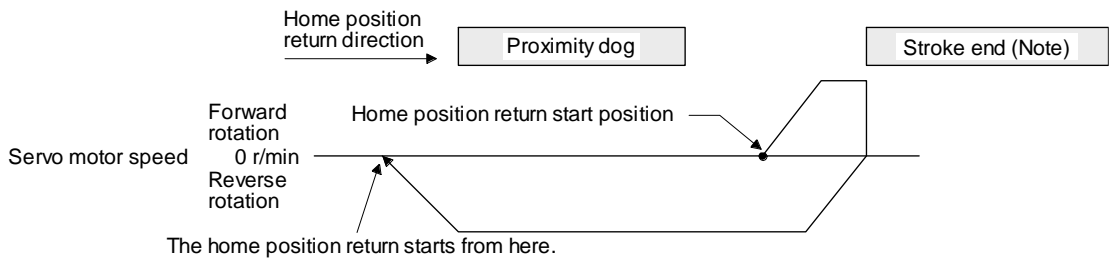

No te.	The software limit cannot be used with these functions.
--------	---

When the movement is returned at the stroke end

(b) Method -2 and -34 (Count type home position return)

POINT

● For the count type home position return, after the front end of the proximity dog is detected, the position is shifted by the distance set in the travel distance after proximity dog. Then, the first Z-phase is set as the home position. Therefore, when the on-time of the proximity dog is 10 ms or more, the length of the proximity dog has no restrictions. Use this home position return type when the dog type home position return cannot be used because the length of the proximity dog cannot be reserved or other cases.

The following figure shows the operation of Homing method -2. The operation direction of Homing method -34 is opposite to that of Homing method -2.

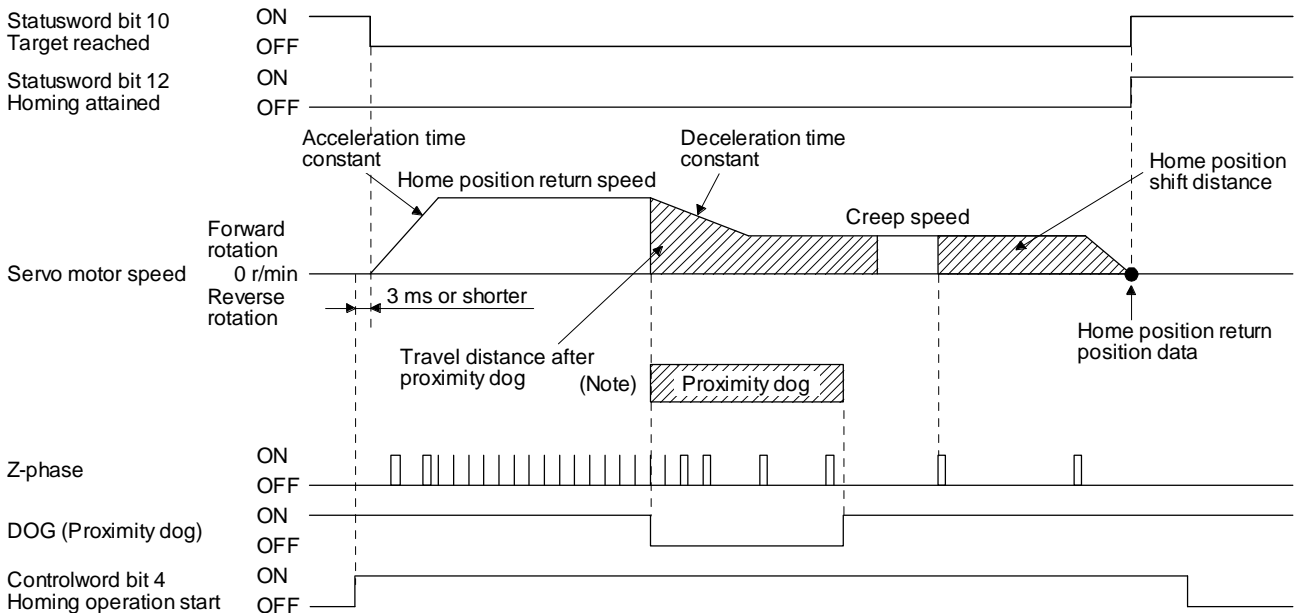

No te. After the front end of the proximity dog is detected, if the distance after proximity dog is traveled without reaching the creep speed, [AL. 90] occurs. Set the travel distance after proximity dog enough for deceleration from the home position return speed to the creep speed.

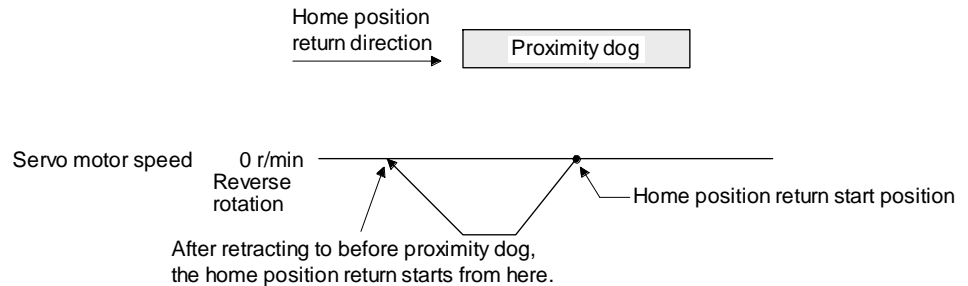

When a home position return is started from the proximity dog

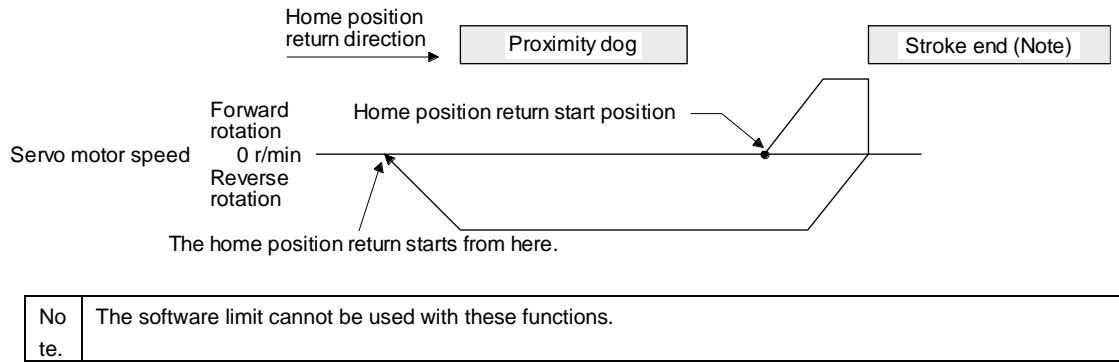

When the movement is returned at the stroke end

(c) Method -3 (Data set type home position return)

The following figure shows the operation of Homing method -3. This type cannot be executed during servo-off.

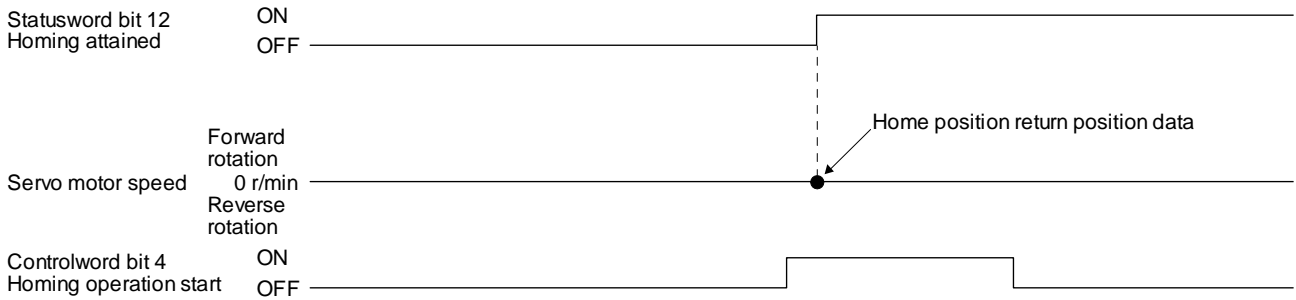

(d) Method -4 and -36 (stopper type home position return)

POINT

● Since the workpiece collides with the mechanical stopper, the home position return speed must be low enough.

The following figure shows the operation of Homing method -4. The operation direction of Homing method -36 is opposite to that of Homing method -4.

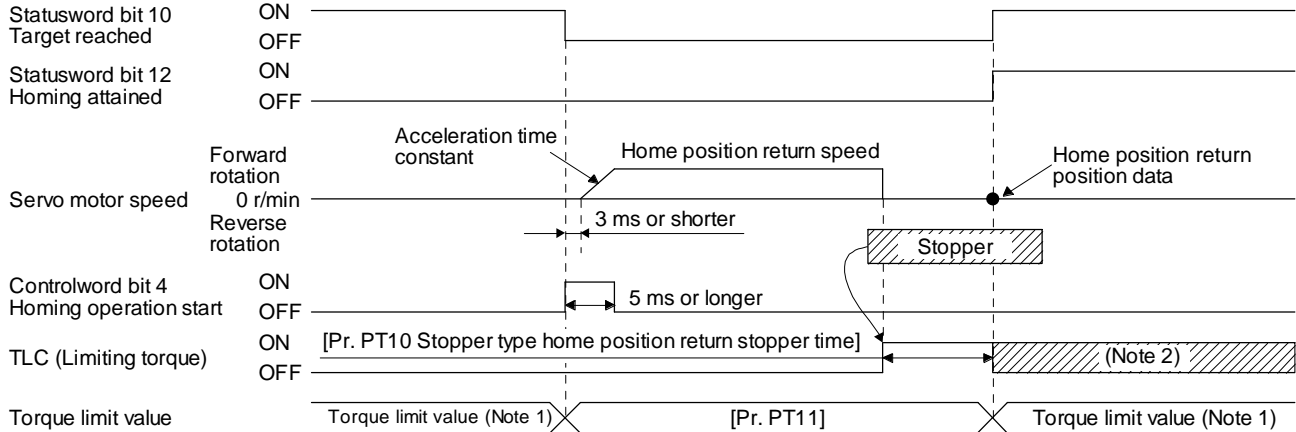

Note	1	When Method -4 is set, the torque limit value of Positive torque limit value (60E0h) is applied. When Method -36 is set, the torque limit value of Negative torque limit value (60E1h) is applied.
	2	If the torque limit value is reached, TLC remains on after the home position return is completed.

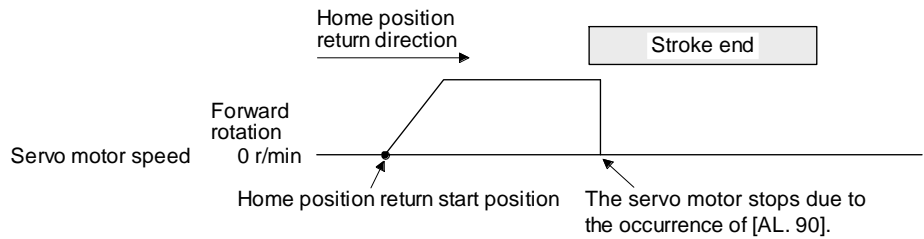

When the stroke end is detected

(e) Method -6 and -38 (dog type rear end reference home position return)

POINT

● This home position return type depends on the timing of reading DOG (Proximity dog) that has detected the rear end of the proximity dog. Therefore, when the creep speed is set to 100 r/min and a home position return is performed, the home position has an error of $\pm (\text{Encoder resolution}) \times 100/65536$ [pulse]. The higher the creep speed, the greater the error of the home position.

The following figure shows the operation of Homing method -6. The operation direction of Homing method -38 is opposite to that of Homing method -6.

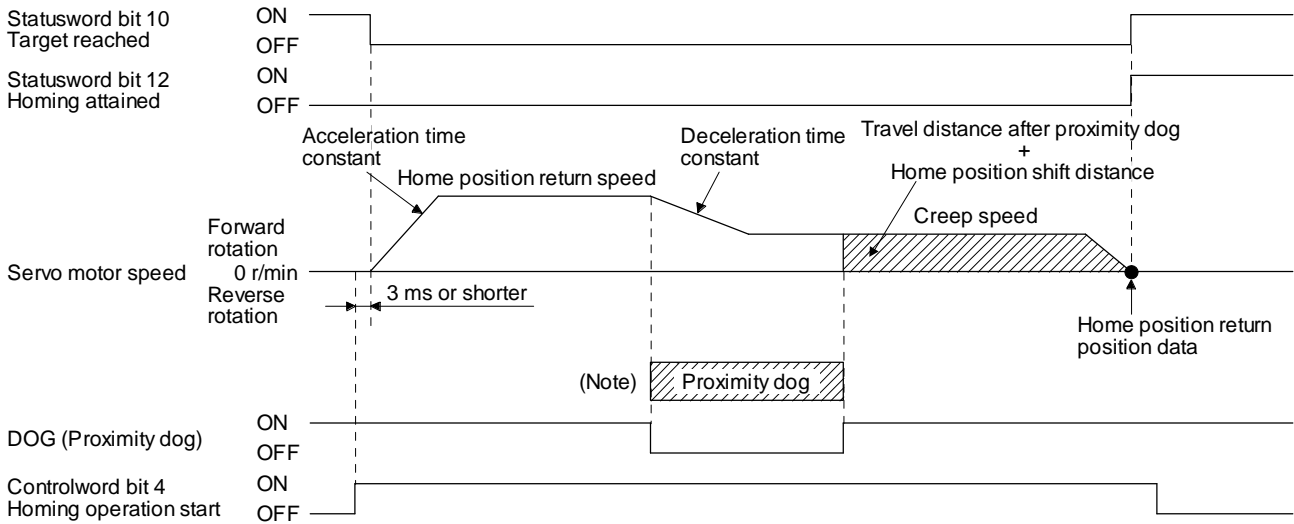

No te. After the front end of the proximity dog is detected, if the rear end of the proximity dog is detected without reaching the creep speed, [AL. 90] occurs. Check the length of the proximity dog or check the home position return speed and creep speed.

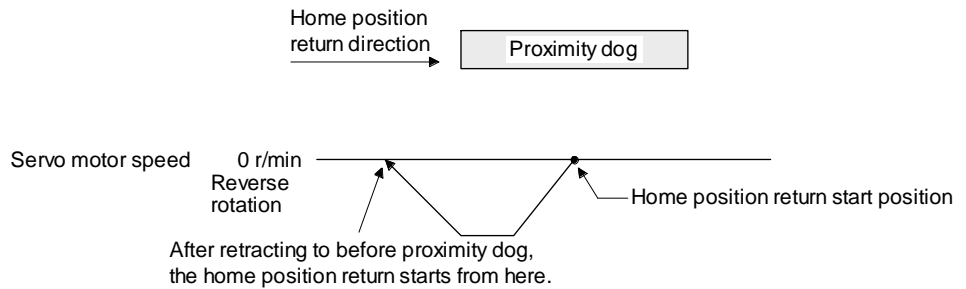

When a home position return is started from the proximity dog

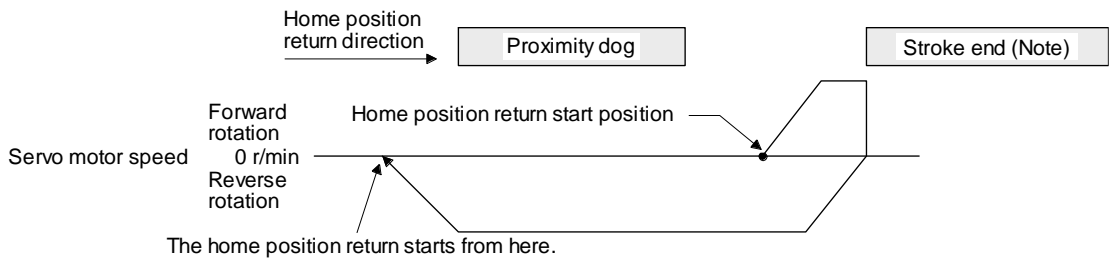

Note. The software limit cannot be used with these functions.

When the movement is returned at the stroke end

(f) Method -7 and -39 (count type front end reference home position return)

POINT

● This home position return type depends on the timing of reading DOG (Proximity dog) that has detected the front end of the proximity dog. Therefore, when the creep speed is set to 100 r/min and a home position return is performed, the home position has an error of $\pm (\text{Encoder resolution}) \times 100/65536$ [pulse]. The faster home position return speed sets a larger error in the home position.

The following figure shows the operation of Homing method -7. The operation direction of Homing method -39 is opposite to that of Homing method -7.

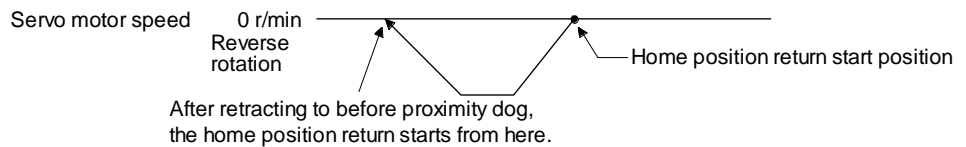
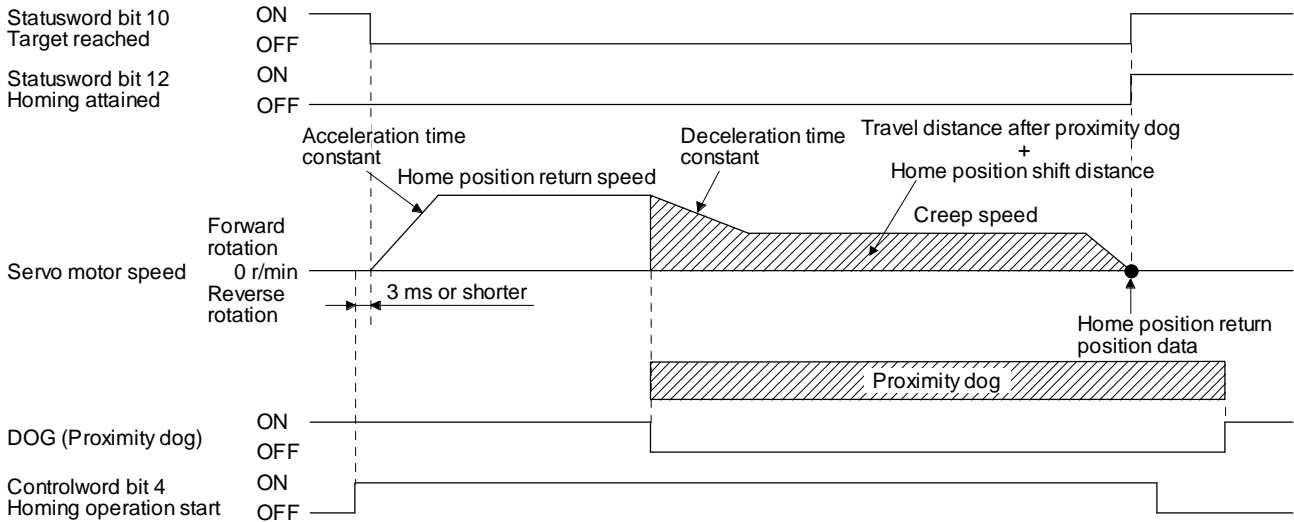

When a home position return is started from the proximity dog

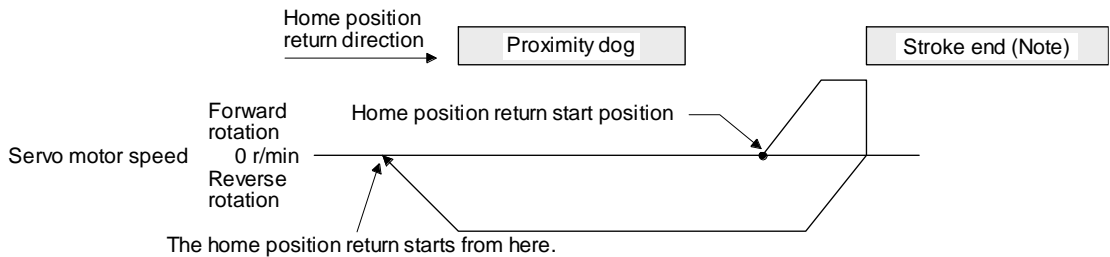

No	The software limit cannot be used with these functions.
te.	

When the movement is returned at the stroke end

(g) Method -8 and -40 (dog cradle type home position return)

The following figure shows the operation of Homing method -8. The operation direction of Homing method -40 is opposite to that of Homing method -8.

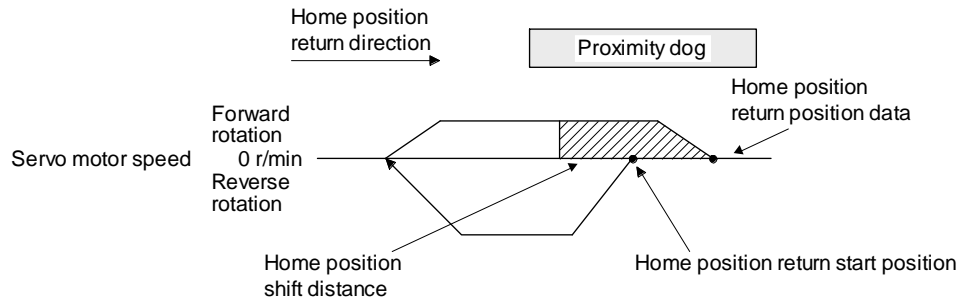
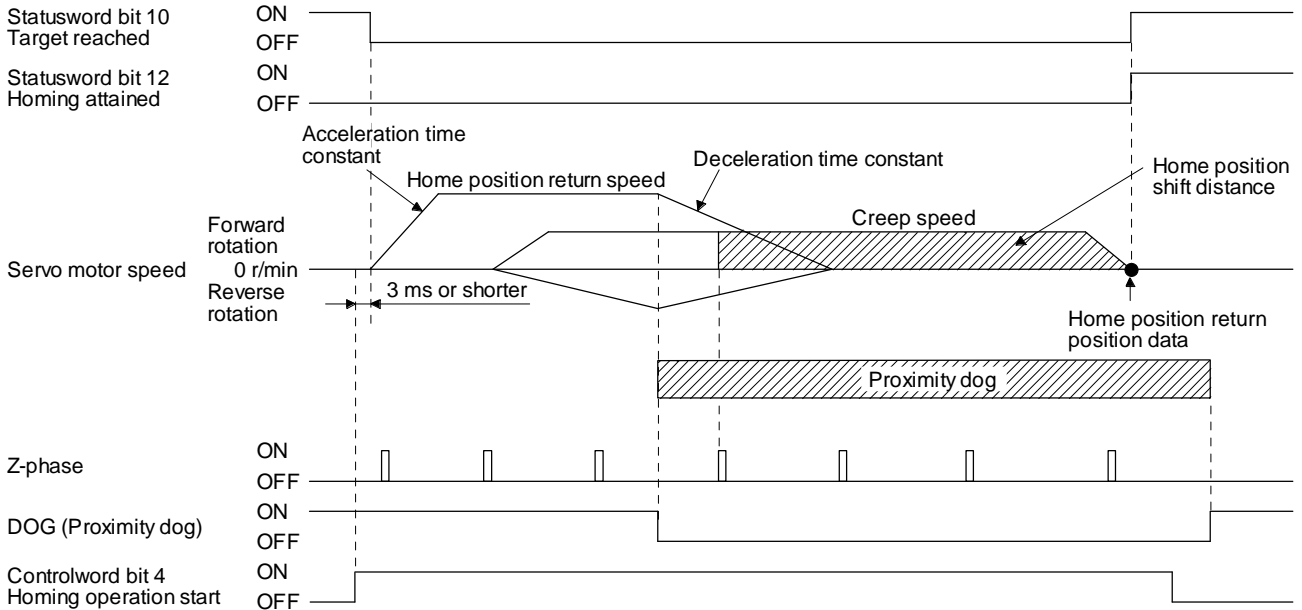

When a home position return is started from the proximity dog

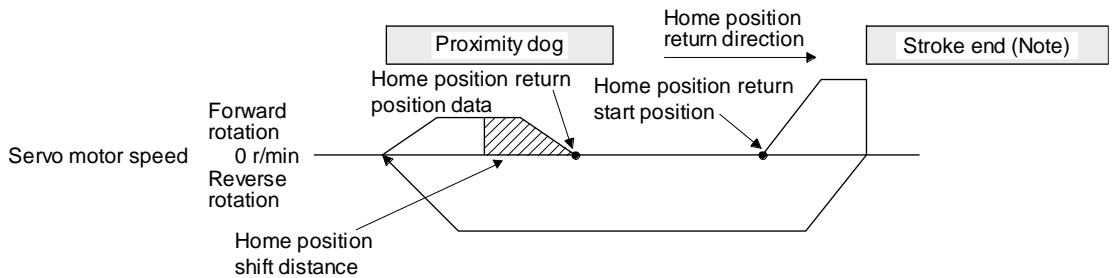

No te.	The software limit cannot be used with these functions.
--------	---

When the movement is returned at the stroke end

(h) Method -9 and -41 (dog type last Z-phase reference home position return)

The following figure shows the operation of Homing method -9. The operation direction of Homing method -41 is opposite to that of Homing method -9.

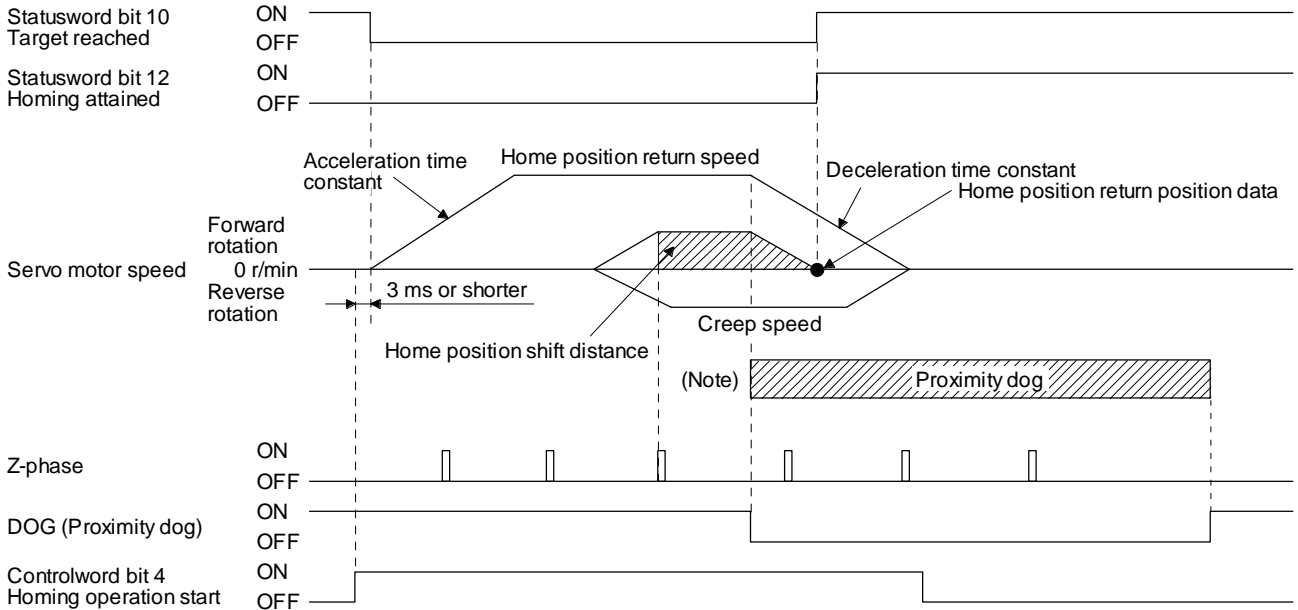

No	After the front end of the proximity dog is detected, if the rear end of the proximity dog is detected without stop, [AL. 90] occurs.
te.	Check the length of the proximity dog or check the home position return speed and creep speed.

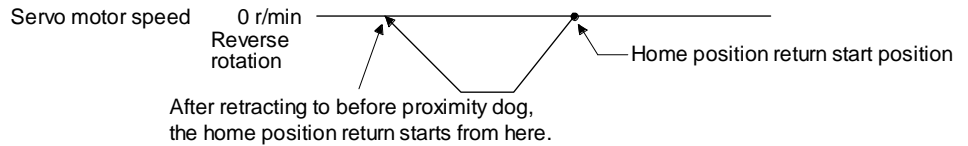

When a home position return is started from the proximity dog

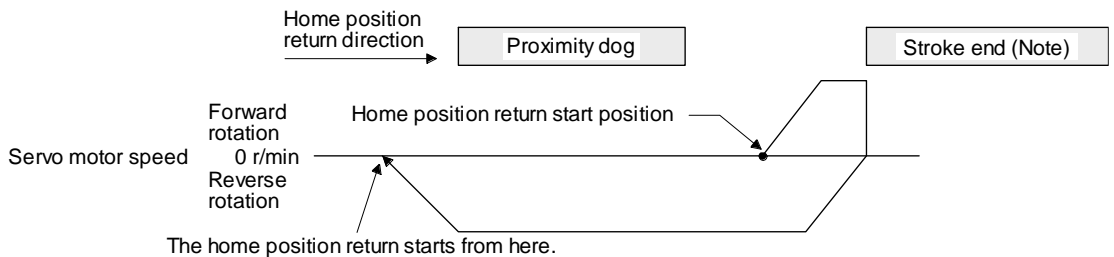

No	The software limit cannot be used with these functions.
te.	

When the movement is returned at the stroke end

(i) Method -10 and -42 (dog type front end reference home position return)

The following figure shows the operation of Homing method -10. The operation direction of Homing method -42 is opposite to that of Homing method -10.

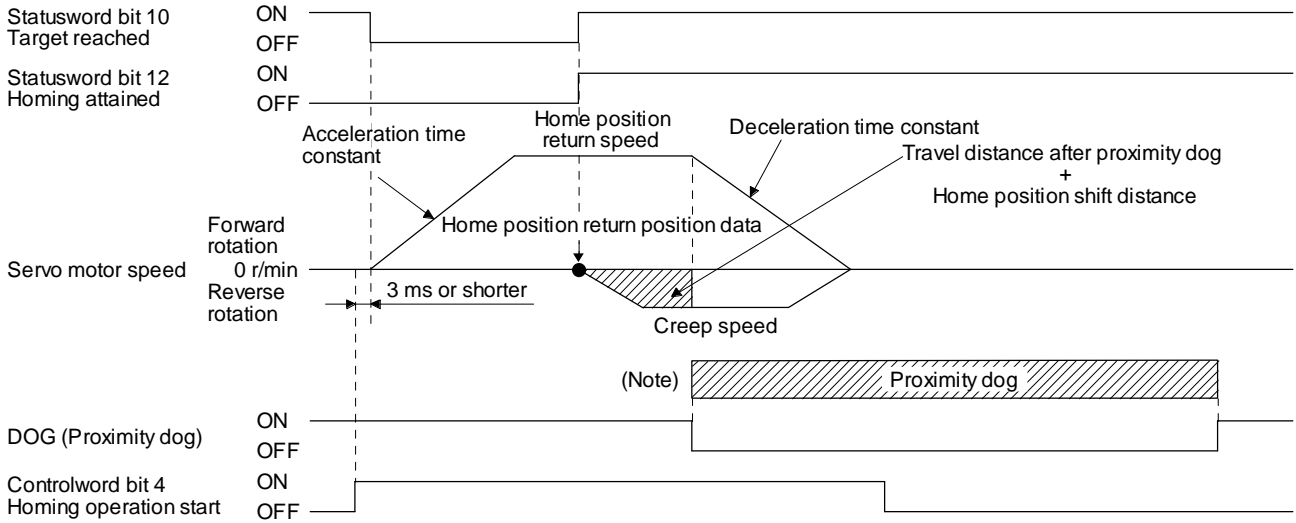

No te.	After the front end of the proximity dog is detected, if the rear end of the proximity dog is detected without reaching the creep speed, [AL. 90] occurs. Check the length of the proximity dog or check the home position return speed and creep speed.
--------	--

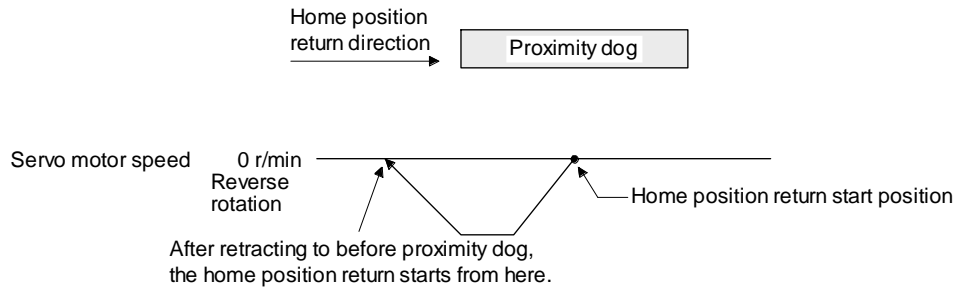

When a home position return is started from the proximity dog

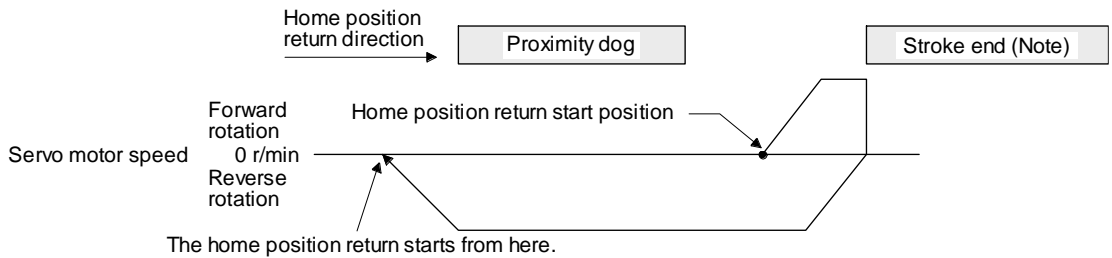

No te.	The software limit cannot be used with these functions.
--------	---

When the movement is returned at the stroke end

(j) Method -11 and -43 (dogless Z-phase reference home position return)

The following figure shows the operation of Homing method -11. The operation direction of Homing method -43 is opposite to that of Homing method -11.

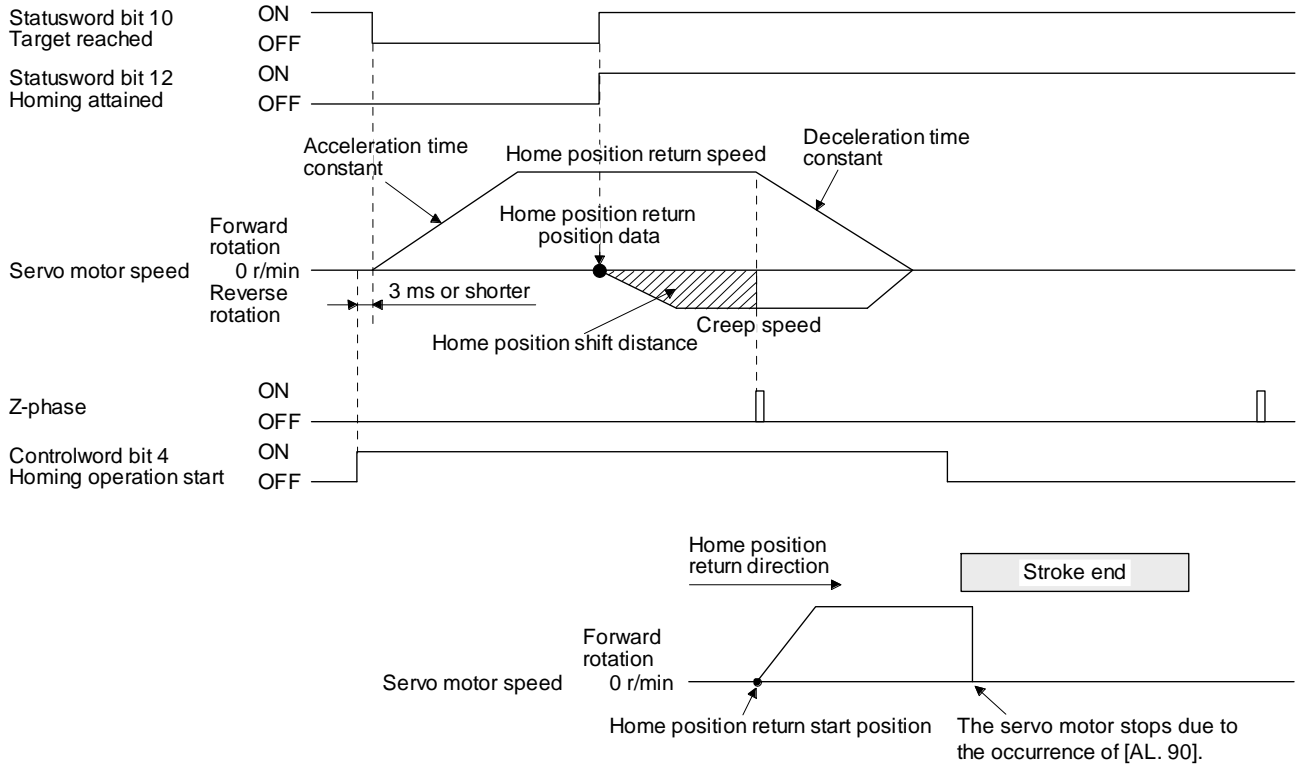

When the stroke end is detected

19. EtherNet/IP COMMUNICATION

19.5.5 Touch probe

The touch probe function that executes current position latch by sensor input can be used.

With this function, the position feedback of the rising edge and falling edge of TPR1 (touch probe 1) and TPR2 (touch probe 2) or the position feedback of when the encoder zero point was passed through can be stored into each object of 60BAh to 60BDh according to the conditions specified in Touch probe function (Class ID: 64h, Ins ID: 60B8h, Attr ID: 0).

The following shows the touch probe detection resolution. Enabling the high precision touch probe will disable the encoder output pulses.

Input terminal		Touch probe1	Touch probe2
Input terminal		TPR1	TPR2
Encoder resolution	[Pr. PD37] = _ _ _ 0 (Selection of high-precision touch probe is disabled)	55 μ s	55 μ s
	[Pr. PD37] = _ _ _ 1 (Selection of high-precision touch probe is enabled)	55 μ s	Rising: 2 μ s Falling: 55 μ s

(1) Related object

Class ID	Ins ID	Attr ID	Access	Name	Data Type	Default	Description
64h	60B8h	0	Get/Set	Touch probe function	UINT		Settings such as enabling/disabling of the touch probe function and trigger conditions
	60B9h	0	Get	Touch probe status	UINT	0	Status information of the touch probe function
	60BAh	0	Get	Touch probe pos1 pos value	DINT	0	Shows the rising edge position of TPR1 (touch probe 1). (Pos units)
	60BBh	0	Get	Touch probe pos1 neg value	DINT	0	Shows the falling edge position of TPR1 (touch probe 1). (Pos units)
	60BCh	0	Get	Touch probe pos2 pos value	DINT	0	Shows the rising edge position of TPR2 (touch probe 2). (Pos units)
	60BDh	0	Get	Touch probe pos2 neg value	DINT	0	Shows the falling edge position of TPR2 (touch probe 2). (Pos units)

(a) Details of Touch probe function (Class ID: 64h, Ins ID: 60B8h, Attr ID: 0)

Bit	Definition
0	0: Touch probe 1 disabled 1: Touch probe 1 enabled
1	0: Single trigger mode 1: Continuous trigger mode
2	0: Set input of touch probe 1 as a trigger 1: Set 0 point of the encoder as a trigger
3	(reserved) The value at reading is undefined. Set "0" when writing.
4	0: Stop sampling at the rising edge of touch probe 1 1: Start sampling at the rising edge of touch probe 1 When the input of touch probe 1 is set as a trigger (Bit 2 = 0), the position feedback latched at rising edge of touch probe 1 is stored in Touch probe pos1 pos value (60BAh). When the encoder zero point is set as a trigger (Bit 2 = 1), the position feedback of when the encoder zero point was passed through is stored in Touch probe pos1 pos value (60BAh).
5	0: Stop sampling at the falling edge of touch probe 1 1: Start sampling at the falling edge of touch probe 1 When the input of touch probe 1 is set as a trigger (Bit 2 = 0), the position feedback latched at falling edge of touch probe 1 is stored in Touch probe pos1 neg value (60BBh). When the encoder zero point is set as a trigger (Bit 2 = 1), the position feedback of when the encoder zero point was passed through is stored in Touch probe pos1 neg value (60BBh).
6	(reserved) The value at reading is undefined. Set "0" when writing.
7	
8	0: Touch probe 2 disabled 1: Touch probe 2 enabled
9	0: Single trigger mode 1: Continuous trigger mode
10	0: Set input of touch probe 2 as a trigger 1: Set 0 point of the encoder as a trigger
11	(reserved) The value at reading is undefined. Set "0" when writing.
12	0: Stop sampling at the rising edge of touch probe 2 1: Start sampling at the rising edge of touch probe 2 When the input of touch probe 2 is set as a trigger (Bit 10 = 0), the position feedback latched at rising edge of touch probe 2 is stored in Touch probe pos2 pos value (60BCh). When the encoder zero point is set as a trigger (Bit 10 = 1), the position feedback of when the encoder zero point was passed through is stored in Touch probe pos2 pos value (60BCh).
13	0: Stop sampling at the falling edge of touch probe 2 1: Start sampling at the falling edge of touch probe 2 When the input of touch probe 2 is set as a trigger (Bit 10 = 0), the position feedback latched at falling edge of touch probe 2 is stored in Touch probe pos2 neg value (60BDh). When the encoder zero point is set as a trigger (Bit 10 = 1), the position feedback of when the encoder zero point was passed through is stored in Touch probe pos2 neg value (60BDh).
14	(reserved) The value at reading is undefined. Set "0" when writing.
15	

(b) Details of Touch probe status (Class ID: 64h, Ins ID: 60B9h, Attr ID: 0)

Bit	Definition
0	0: Touch probe 1 disabled 1: Touch probe 1 enabled
1	0: The rising edge position of touch probe 1 has not been stored. 1: The rising edge position of touch probe 1 has been stored. When the position feedback is stored in Touch probe pos1 pos value (60BAh), this bit becomes "1". When "0" is set in the bit 4 of Touch probe function (60B8h), this bit becomes "0".
2	0: The falling edge position of touch probe 1 has not been stored. 1: The falling edge position of touch probe 1 has been stored. When the position feedback is stored in Touch probe pos1 neg value (60BBh), this bit becomes "1". When "0" is set in the bit 5 of Touch probe function (60B8h), this bit becomes "0".
3	(reserved) The value at reading is undefined. Set "0" when writing.
4	
5	
6	
7	
8	0: Touch probe 2 disabled 1: Touch probe 2 enabled
9	0: The rising edge position of touch probe 2 has not been stored. 1: The rising edge position of touch probe 2 has been stored. When the position feedback is stored in Touch probe pos2 pos value (60BCh), this bit becomes "1". When "0" is set in the bit 12 of Touch probe function (60B8h), this bit becomes "0".
10	0: The falling edge position of touch probe 2 has not been stored. 1: The falling edge position of touch probe 2 has been stored. When the position feedback is stored in Touch probe pos2 neg value (60BDh), this bit becomes "1". When "0" is set in the bit 13 of Touch probe function (60B8h), this bit becomes "0".
11	(reserved) The value at reading is undefined. Set "0" when writing.
12	
13	
14	
15	

19. EtherNet/IP COMMUNICATION

(2) Timing chart

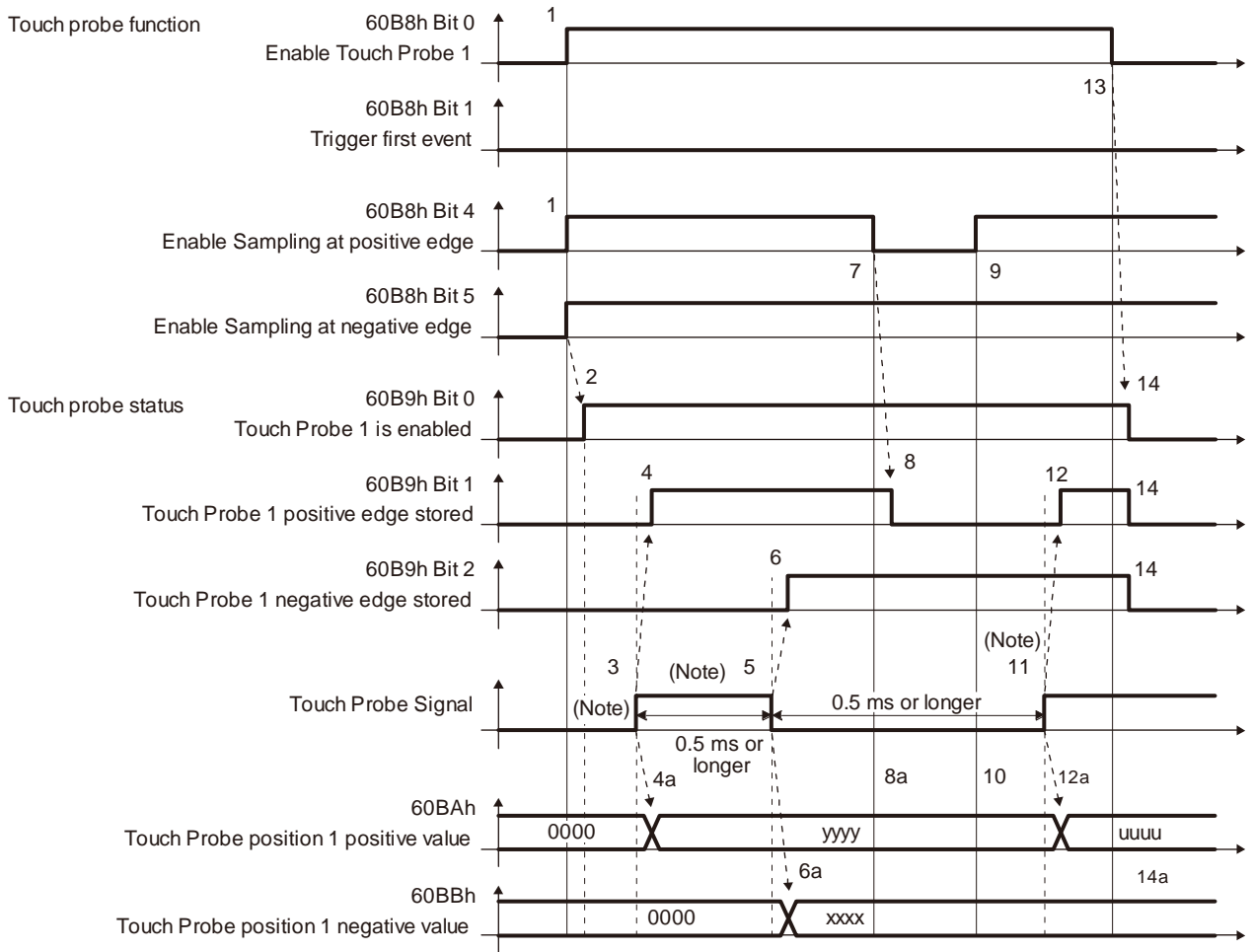

No te.	Turn on and off Touch Probe Signal so that both the on time and off time are 0.5 ms or longer.
--------	--

Transition No.	Object	Description
1	60B8h Bit 0, 4, 5 = 1	Enables Touch Probe1. The rising edge and falling edge are enabled.
2	→ 60B9h Bit 0 = 1	Turns on the Touch Probe1 enable status.
3		Turns on Touch Probe Signal (TPR1).
4	→ 60B9h Bit 1 = 1	Turns on the Touch Probe1 positive edge stored status.
4a	→ 60BAh	Sets the latched position feedback for Touch probe position1 positive value.
5		Turns off Touch Probe Signal (TPR1).
6	→ 60B9h Bit 2 = 1	Turns on the Touch Probe1 negative edge stored status.
6a	→ 60BBh	Sets the latched position feedback for Touch probe position1 negative value.
7	60B8h Bit 4 = 0	Turns off Sample positive edge. Rising edge detection is disabled.
8	→ 60B9h Bit 1 = 0	Turns off Touch Probe1 positive edge stored status.
8a	→ 60BAh	Touch probe position1 positive value does not change.
9	60B8h Bit 4 = 1	Turns on Sample positive edge. Rising edge detection is enabled.
10	→ 60BAh	Touch probe position1 positive value does not change.
11		Turns on Touch Probe Signal (TPR1).
12	→ 60B9h Bit 1 = 1	Turns on the Touch Probe1 negative edge stored status.
12a	→ 60BAh	Sets the latched position feedback for Touch probe position1 negative value.
13	60B8h Bit 0 = 0	Disables Touch Probe1.
14	→ 60B9h Bit 0, 1, 2 = 0	Clears all the status Bit.
14a	→ 60BAh, 60BBh	Touch probe position1 positive/negative value does not change.

(3) High-precision touch probe

TPR2 (touch probe 2) supports high-precision touch probe. The normal touch probe has the latch function with precision of 55 μ s. On the other hand, the high-precision touch probe latches precisely startup of TPR2 (touch probe 2) with precision of 2 μ s. To use the high-precision touch probe, set [Pr. PD37] to "___ 1". While the high-precision touch probe is being used, the encoder pulse output function cannot be used. The precision of falling edge is 55 μ s in this case as well.

19. 5. 6 Quick stop

Decelerate the servo motor to a stop with the Quick stop command of Controlword (Class ID: 64h, Ins ID: 6040h, Attr ID: 0). The following table shows the related objects.

Class ID	Ins ID	Attr ID	Access	Name	Data Type	Default	Description
64h	6085h	0	Get/Set	Quick stop deceleration	UDINT	100	Deceleration at deceleration to a stop by Quick stop Unit: ms
	605Ah	0	Get/Set	Quick stop option code	INT	2	Refer to table 5.2 for details.

The operation method of deceleration to a stop can be specified with Quick stop option code (Class ID: 64h, Ins ID: 605Ah, Attr ID: 0). The following table shows the supported methods and the operations.

Table 5.2 Quick stop option code

Setting value	Description
1 (Not supported) (Note)	tq: The state shifts to the Switch on disabled state and the servo motor is stopped with the dynamic brake. pp/pv: The servo motor decelerates to a stop with Profile deceleration (Class ID: 64h, Ins ID: 6084h, Attr ID: 0) and the state immediately shifts to the Switch On Disabled state. hm: The servo motor decelerates to a stop with Homing acceleration (Class ID: 64h, Ins ID: 609Ah, Attr ID: 0) and the state shifts to the Switch On Disabled state.
2	In the profile mode (pp/pv), and homing mode (hm), the servo motor decelerates to a stop with Quick stop deceleration (Class ID: 64h, Ins ID: 6085h, Attr ID: 0) and the state shifts to the Switch On Disabled state. In the profile torque mode (tq), the state immediately shifts to the Switch On Disabled state and the servo motor stops with the dynamic brake.
3 (Not supported) (Note)	The current is limited and the servo motor decelerates to a stop. Then, the state shifts to the Switch On Disabled state.
4 (Not supported) (Note)	The voltage is limited and the servo motor decelerates to a stop. Then, the state shifts to the Switch On Disabled state.
5 (Not supported) (Note)	The servo motor decelerates to a stop. The state does not change from the Quick Stop Active state (servo-on).
6 (Not supported) (Note)	The servo motor decelerates to a stop with Quick stop deceleration (Class ID: 64h, Ins ID: 6085h, Attr ID: 0). The state does not change from the Quick Stop Active state (servo-on).
7 (Not supported) (Note)	The current is limited and the servo motor decelerates to a stop. The state does not change from the Quick Stop Active state (servo-on).
8 (Not supported) (Note)	The voltage is limited and the servo motor decelerates to a stop. The state does not change from the Quick Stop Active state (servo-on).

Note. This is not supported by the driver.

19. EtherNet/IP COMMUNICATION

19.5.7 Halt

When Halt Bit (Bit 8 of Controlword) is set to 1, the servo motor decelerates to a stop with the deceleration time constant of Homing acceleration (Class ID: 64h, Ins ID: 609Ah, Attr ID: 0) or Profile deceleration (Class ID: 64h, Ins ID: 6084h, Attr ID: 0) according to the setting of Halt option code (Class ID: 64h, Ins ID: 605Dh, Attr ID: 0). The halt function can be used in the profile mode (pp/pv/tq) and homing mode (hm). When Halt Bit is set to 0 at deceleration stop operation, the servo motor decelerates to a stop and returns to the operable state. The following table shows the related object.

Class ID	Ins ID	Attr ID	Access	Name	Data Type	Default	Description
64h	605Dh	0	Get/Set	Halt option code	INT	1	Setting for executing the Halt function Refer to table 5.3 for details.

The following table shows descriptions of Halt option code (Class ID: 64h, Ins ID: 605Dh, Attr ID: 0). However, in the profile torque mode (tq), Torque demand value (Class ID: 64h, Ins ID: 6074h, Attr ID: 0) is set to 0 regardless of Halt option code (Class ID: 64h, Ins ID: 605Dh, Attr ID: 0). The amount of torque change at this time can be set using Torque slope (Class ID: 64h, Ins ID: 6087h, Attr ID: 0).

Table 5.3 Halt option code

Setting value	Description
1	For Profile deceleration (Class ID: 64h, Ins ID: 6084h, Attr ID: 0) and the homing mode (hm), the servo motor decelerates to a stop according to Homing acceleration (Class ID: 64h, Ins ID: 609Ah, Attr ID: 0) and the state does not change from the Operation Enabled state (servo-on).
2 (Not supported) (Note)	The servo motor decelerates to a stop with Quick stop deceleration (Class ID: 64h, Ins ID: 6085h, Attr ID: 0). The state does not change from the Operation Enabled state (servo-on).
3 (Not supported) (Note)	The current is limited and the servo motor decelerates to a stop. The state does not change from the Operation Enabled (servo-on).
4 (Not supported) (Note)	The voltage is limited and the servo motor decelerates to a stop. The state does not change from the Operation Enabled (servo-on).

Note. This is not supported by the driver.

19. EtherNet/IP COMMUNICATION

19.5.8 Software position limit

Specify the upper and lower limits of the command position and current position. If a command position exceeding the limit position is specified, the command position is clamped at the limit position. Specify a relative position from the machine home point (position address = 0) as the limit position.

This function is enabled when the home position is not erased in the profile position mode (pp). While the clamp processing is being performed with the command position exceeding the limit value, [AL. 98 Software limit warning] occurs and not cleared. When the position command of the direction opposite to reached Software position limit (Class ID: 64h, Ins ID: 607Dh, Attr ID: 0) is given, the operation can be restarted.

Class ID	Ins ID	Attr ID	Access	Name	Data Type	Default	Description
64h	607Dh	0	Get	Software position limit	USINT	2	Number of entries
		1	Get/Set	Min position limit (Note)	DINT	0	Specify a relative position from the machine home point (position address = 0) as the minimum value of the command position and current position. When the value falls below the minimum value, it is clamped and processed as the minimum value.
		2	Get/Set	Max position limit (Note)	DINT	0	Specify a relative position from the machine home point (position address = 0) as the maximum value of the command position and current position. When the value exceeds the maximum value, it is clamped and processed as the maximum value.

Note: When the set value of Min position limit is equal to or greater than the set value of Max position limit, the function of Software position limit (607Dh) is disabled.

19.5.9 Torque limit

Generated torque can be limited with the values of Positive torque limit value (60E0h) and Negative torque limit value (60E1h). When "0" is set, torque () is not generated. The following table lists the related objects.

Class ID	Ins ID	Attr ID	Access	Name	Data Type	Default	Description
64h	60E0h	0	Get/Set	Positive torque limit value	UINT	10000	[Pr. PA11 Forward rotation torque limit/positive direction limit] Torque limit value in CCW power running/CW regeneration Unit: 0.1% (rated torque of 100%) Range: 0 to 10000
	60E1h	0	Get/Set	Negative torque limit value	UINT	10000	[Pr. PA12 Reverse rotation torque limit/negative direction limit] Torque limit value in CW power running/CCW regeneration Unit: 0.1% (rated torque of 100%) Range: 0 to 10000

19. EtherNet/IP COMMUNICATION

19.5.10 Polarity

The rotation direction of a servo motor to position commands, speed commands, and torque commands can be set with Polarity (Class ID: 64h, Ins ID: 607Eh, Attr ID: 0). For the Polarity (Class ID: 64h, Ins ID: 607Eh, Attr ID: 0) setting to position commands and speed commands, use [Pr. PA14]. For the Polarity (Class ID: 64h, Ins ID: 607Eh, Attr ID: 0) setting to torque commands, use [Pr. PA14] and "POL reflection selection at torque mode" of [Pr. PC29]. A change in the setting of Polarity (Class ID: 64h, Ins ID: 607Eh, Attr ID: 0) is not applied without enabling the change. Refer to section 6.5.2 for the procedure of enabling parameters.

(1) Object definition

Bit	Description
0	(reserved) The value at reading is undefined. Set "0" at writing.
1	
2	
3	
4	
5	Torque POL The polarity is reversed when this bit is turned on.
6	Velocity POL The polarity is reversed when this bit is turned on.
7	Position POL The polarity is reversed when this bit is turned on.

19. EtherNet/IP COMMUNICATION

(2) Target object

The following shows objects whose polarity is reversed according to the setting of Polarity (Class ID: 64h, Ins ID: 607Eh, Attr ID: 0).

Object name (Class ID, Ins ID, Attr ID)	Remark
Target position (64h, 607Ah, 0)	
Target velocity (64h, 60FFh, 0)	
Target torque (64h, 6071h, 0)	
Position actual value (64h, 6064h, 0)	
Velocity demand value (64h, 606Bh, 0)	Whether to reverse the polarity using Polarity (607Eh) can be switched with "Internal command speed POL reflection selection" of [Pr. PC76]. [Pr. PC76] = _ 0 __ (Automatic setting): Automatically set depending on the type of the network in use. [Pr. PC76] = _ 1 __ (POL setting enabled): The polarity is reversed using Polarity. [Pr. PC76] = _ 2 __ (POL setting disabled): The polarity is not reversed using Polarity.
Velocity actual value (64h, 606Ch, 0)	
Torque demand (64h, 6074h, 0)	
Torque actual value (64h, 6077h, 0)	
Positive torque limit value (64h, 60E0h, 0)	The corresponding parameters are changed according to "POL reflection selection at torque mode" in [Pr. PA14] and [Pr. PC29] as follows. [Pr. PA14] = 0, [Pr. PC29] = 1 ___ (Disabled): Written to [Pr. PA11 Forward rotation torque limit/positive direction limit]. [Pr. PA14] = 1, [Pr. PC29] = 1 ___ (Disabled): Written to [Pr. PA11 Forward rotation torque limit/positive direction limit]. [Pr. PA14] = 0, [Pr. PC29] = 0 ___ (Enabled): Written to [Pr. PA11 Forward rotation torque limit/positive direction limit]. [Pr. PA14] = 1, [Pr. PC29] = 0 ___ (Enabled): Written to [Pr. PA12 Reverse rotation torque limit/negative direction limit].
Negative torque limit value (64h, 60E1h, 0)	The corresponding parameters are changed according to "POL reflection selection at torque mode" in [Pr. PA14] and [Pr. PC29] as follows. [Pr. PA14] = 0, [Pr. PC29] = 1 ___ (Disabled): Written to [Pr. PA12 Reverse rotation torque limit/negative direction limit]. [Pr. PA14] = 1, [Pr. PC29] = 1 ___ (Disabled): Written to [Pr. PA12 Reverse rotation torque limit/negative direction limit]. [Pr. PA14] = 0, [Pr. PC29] = 0 ___ (Enabled): Written to [Pr. PA12 Reverse rotation torque limit/negative direction limit]. [Pr. PA14] = 1, [Pr. PC29] = 0 ___ (Enabled): Written to [Pr. PA11 Forward rotation torque limit/positive direction limit].
Digital inputs (64h, 60FDh, 0)	The corresponding status is changed according to the setting of [Pr. PA14] as follows. [Pr. PA14] = 0: The status of LSN (reverse rotation stroke end) is applied to Negative limit switch (bit 0). The status of LSP (forward rotation stroke end) is applied to Positive limit switch (bit 1). [Pr. PA14] = 1: The status of LSP (forward rotation stroke end) is applied to Negative limit switch (bit 0). The status of LSN (reverse rotation stroke end) is applied to Positive limit switch (bit 1).

19. EtherNet/IP COMMUNICATION

19.5.11 Degree function

(1) Summary

Selecting "degree (_ 2 _)" in "Position data unit" of [Pr. PT01] allows for positioning with card coordinates (axis of rotation). The following shows the differences when "degree" is selected.

Item (Class ID, Ins ID, Attr ID)	Description
Target position (64h, 607Ah, 0)	The range will be -360.000° to 360.000°.
Position actual value (64h, 6064h, 0)	The range will be 0° to 359.999°.
Software position limit (64h, 607Dh, 0)	The range will be 0° to 359.999°. A value outside the range is clamped within the range 0° to 359.999°.
Position range limit (64h, 607Bh, 0)	The range will be 0° to 359.999°.
Touch probe pos1 pos value (64h, 60BAh, 0)	The range will be 0° to 359.999°.
Touch probe pos1 neg value (64h, 60BBh, 0)	The range will be 0° to 359.999°.
Touch probe pos2 pos value (64h, 60BCh, 0)	The range will be 0° to 359.999°.
Touch probe pos2 neg value (64h, 60BDh, 0)	The range will be 0° to 359.999°.
Home offset (64h, 607Ch, 0)	The range will be 0° to 359.999°.

(2) Setting of the operation pattern

Positioning operation patterns can be changed with Positioning option code (Class ID: 64h, Ins ID: 60F2h, Attr ID: 0) or [Pr. PT03]. Change the setting while the servo motor is stopped (Target reached is on). If the setting is changed while the servo motor is rotating (Target reached is off), the setting value is not applied immediately. The new value is applied at a positioning start (Bit 4 of Controlword is turned on) after Target reached is once turned on. The following table shows the bit of Positioning option code (Class ID: 64h, Ins ID: 60F2h, Attr ID: 0) and the setting of [Pr. PT03].

Bit 7	Bit 6	[Pr. PT03]	Rotation direction definition for the axis of rotation
0	0	_ 0 _ _	The servo motor rotates to the target position in a direction specified with a sign of the position data.
0	1	_ 2 _ _	The servo motor rotates in the address decreasing direction regardless of the sign of the position data.
1	0	_ 3 _ _	The servo motor rotates in the address increasing direction regardless of the sign of the position data.
1	1	_ 1 _ _	The servo motor rotates from the current position to the target position in the shorter direction. If the distances from the current position to the target position are the same for CCW and CW, the servo motor rotates in the CCW direction.

(3) Sequence

The following shows the operation patterns corresponding to the settings of Positioning option code (Class ID: 64h, Ins ID: 60F2h, Attr ID: 0).

(a) When POL is disabled ([Pr. PA14] = 0)

<p>Bit 7: 0 Bit 6: 0 The servo motor rotates in a direction specified with a sign of the position data.</p>	<p>Bit 7: 0 Bit 6: 1 The servo motor rotates only in the address decreasing direction.</p>	<p>Bit 7: 1 Bit 6: 0 The servo motor rotates only in the address increasing direction.</p>	<p>Bit 7: 1 Bit 6: 1 The servo motor rotates in the shorter direction.</p>

(b) When POL is enabled ([Pr. PA14] = 1)

<p>Bit 7: 0 Bit 6: 0 The servo motor rotates in a direction specified with a sign of the position data.</p>	<p>Bit 7: 0 Bit 6: 1 The servo motor rotates only in the address decreasing direction.</p>	<p>Bit 7: 1 Bit 6: 0 The servo motor rotates only in the address increasing direction.</p>	<p>Bit 7: 1 Bit 6: 1 The servo motor rotates in the shorter direction.</p>

19. EtherNet/IP COMMUNICATION

19.6 MANUFACTURER FUNCTIONS

19.6.1 Object for status monitor

The monitor data as the manufacturer functions can be checked with the objects in the following table.

Class ID	Ins ID	Attr ID	Access	Name	Data Type	Default	Description
64h	2B0 1h	0	Get/ Set	Monitor 1 Cumulative feedback pulses	DIN T		Cumulative feedback pulses (Unit: pulse) Cleared by writing "00001EA5h".
	2B0 2h	0	Get	Monitor 2 Servo motor speed	DIN T		Servo motor speed (Unit: r/min)
	2B0 3h	0	Get	Monitor 3 Droop pulse	DIN T		Droop pulses (Unit: pulse)
	2B0 4h	0	Get	Monitor 4 Cumulative command pulses	DIN T		Cumulative command pulses (Unit: pulse) Cleared by writing "00001EA5h".
	2B0 5h	0	Get	Monitor 5 Command pulse frequency	DIN T		Command pulse frequency (Unit: kpulse/s)
	2B0 8h	0	Get	Monitor 8 Regenerative load ratio	UIN T		Regenerative load ratio (Unit: %)
	2B0 9h	0	Get	Monitor 9 Effective load ratio	UIN T		Effective load ratio (Unit: %)
	2B0 Ah	0	Get	Monitor 10 Peak load ratio	UIN T		Peak load ratio (Unit: %)
	2B0 Bh	0	Get	Monitor 11 Instantaneous torque	INT		Instantaneous torque (Unit: %)
	2B0 Ch	0	Get	Monitor 12 Within one-revolution position	DIN T		Position within one-revolution (Unit: pulse)
	2B0 Dh	0	Get	Monitor 13 ABS counter	DIN T		ABS counter (Unit: rev)
	2B0 Eh	0	Get	Monitor 14 Load to motor inertia ratio	UIN T		Load to motor inertia ratio (Unit: 0.01 times)
	2B0 Fh	0	Get	Monitor 15 Bus voltage	UIN T		Bus voltage (Unit: V)
	2B1 0h	0	Get	Monitor 16 Load side encoder cumulative feedback pulses	DIN T		Load-side encoder cumulative feedback pulses (Unit: pulse)
	2B1 1h	0	Get	Monitor 17 Load side encoder droop pulses	DIN T		Load-side encoder droop pulses (Unit: pulse)
	2B1 2h	0	Get	Monitor 18 Load side encoder information 1	DIN T		Load-side encoder information 1 (Unit: pulse)
	2B1 3h	0	Get	Monitor 19 Load side encoder information 2	DIN T		Load-side encoder information 2 (Unit: rev)
	2B1 7h	0	Get	Monitor 23 Temperature of motor thermistor	INT		Temperature of servo motor thermistor (Unit: °C)
	2B1 8h	0	Get	Monitor 24 Motor side cumulative F/B pulses (Before Gear)	DIN T		Servo motor-side cumulative feedback pulses (before gear) (Unit: pulse)
	2B1 9h	0	Get	Monitor 25 Electrical angle	DIN T		Electrical angle (Unit: pulse)
2B2 3h	0	Get	Monitor 35 Motor/load side position deviation	DIN T		Servo motor-side/load-side position deviation (Unit: pulse)	
2B2 4h	0	Get	Monitor 36 Motor/load side speed deviation	DIN T		Servo motor-side/load-side speed deviation (Unit: r/min)	

19. EtherNet/IP COMMUNICATION

Class ID	Ins ID	Attr ID	Access	Name	Data Type	Default	Description
64h	2B2 5h	0	Get	Monitor 37 Internal temperature of encoder	INT		Internal temperature of encoder (Unit: °C)
	2B2 6h	0	Get	Monitor 38 Settling time	INT		Settling time (Unit: ms)
	2B2 7h	0	Get	Monitor 39 Oscillation detection frequency	INT		Oscillation detection frequency (Unit: Hz)
	2B2 8h	0	Get	Monitor 40 Number of tough drive operations	UDINT		Number of tough drive operations (Unit: time)
	2B2 Dh	0	Get	Monitor 45 Unit power consumption	INT		Unit power consumption (Unit: W)
	2B2 Eh	0	Get	Monitor 46 Unit total power consumption	DINT		Unit total power consumption (Unit: Wh)

19. EtherNet/IP COMMUNICATION

19.6.2 Instruction code

19.6.2.1 Summary

If you set the code corresponding to an item to be read/written from/to the Instruction code object through the cyclic communication, the master can change or read parameter values and object values of a driver. The following table lists the instruction code objects.

Name	Data Type	Access	Description
Instruction code	UDINT	Get/Set	Instruction code
Writing data	DINT	Get/Set	Writing data
Respond code	UINT	Get	Respond code
Reading data	DINT	Get	Reading data

19.6.2.2 Reading instruction codes

(1) Timing chart

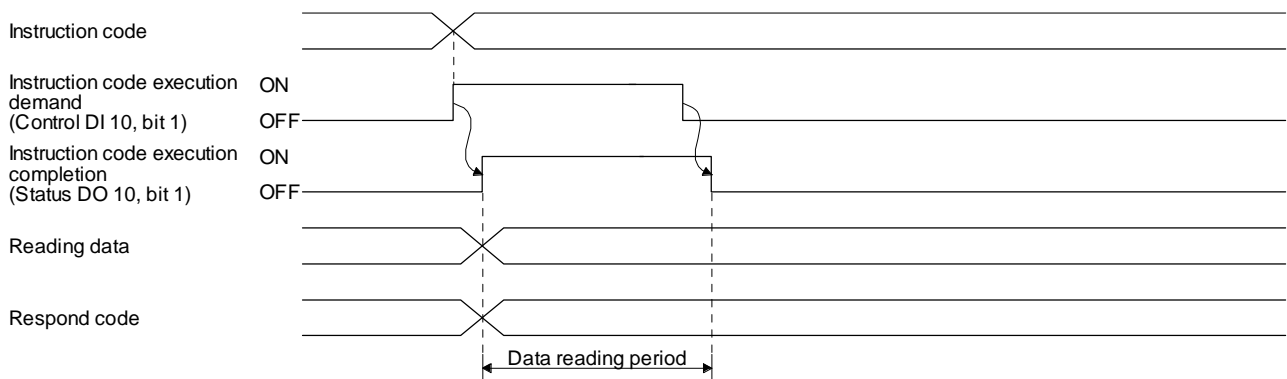

Set the reading instruction code (refer to (2) in this section) in Instruction code and turn on Instruction code execution demand (Control DI 10, bit 1). Turning on Instruction code execution demand (Control DI 10, bit 1) sets the data corresponding to the set reading code in Reading data. Data is all hexadecimal. At this time, Instruction code execution completion (Status DO 10, bit 1) also turns on. Read the reading data to be set in Reading data while Instruction code execution demand (Control DI 10, bit 1) is on. The data set in Reading data is held until Instruction code execution demand (Control DI 10, bit 1) turns on with the next reading instruction code set.

If an instruction code out of the specifications is set in Instruction code, an error code (_ _ 1 _) is set in Respond code. At this time, "00000000" is stored in Reading data. Refer to section 6.2.5 for details of the respond code.

Turn off Instruction code execution demand (Control DI 10, bit 1) after the data reading is completed. Until Instruction code execution completion turns on after Instruction code execution demand is turned on, do not change the instruction code. Turn off Instruction code execution demand after the data reading is completed.

(2) Instruction code

Code No.	Item/function	Reading data content (Driver → Master station)	
		Lower 16 bits	Upper 16 bits
10XXXXYYh	Reading an object library Reads the value of an object library that can be read when the object library is set as follows: Ins ID is set to XXXX and Attr ID is set to YY. An error code is returned if an object library that cannot be read is specified.	The read value of the requested object library is stored. (Note)	The upper 16 bits of the value is stored. (Note)

Note. If the size of an object to be read is smaller than 32 bits, 0 is stored in the remaining areas.

19. 6. 2. 3 Writing instruction code

(1) Timing chart

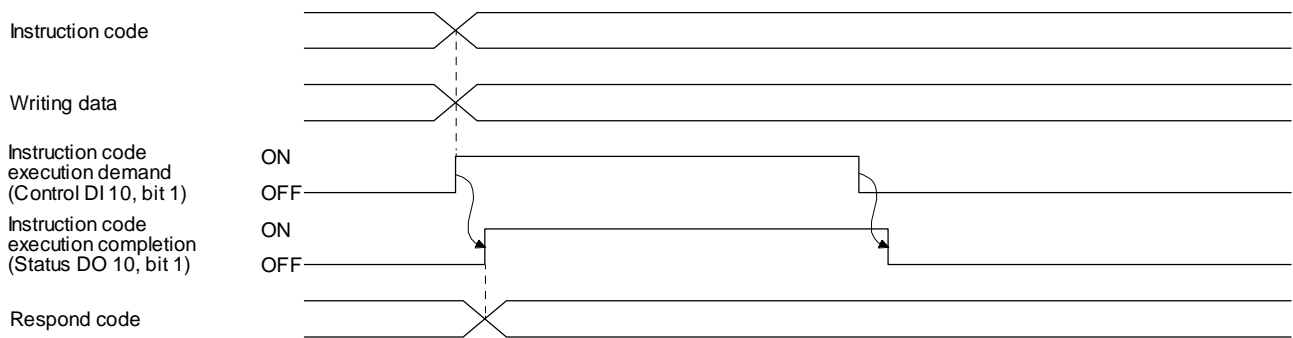

Set a writing instruction code (refer to (2) in this section) in Instruction code, set the data to be written (data to be executed) in Writing data in hexadecimal, and turn on Instruction code execution demand (Control DI 10, bit 1).

Turning on Instruction code execution demand (Control DI 10, bit 1) writes the data set with Writing data to the item corresponding to the writing instruction code. After the writing is completed, Instruction code execution completion (Status DO 10, bit 1) turns on.





If an instruction code out of the specifications is set in Instruction code, an error code (_ _ 1 _) is set in Respond code.

Turn off Instruction code execution demand (Control DI 10, bit 1) after Instruction code execution completion (Status DO 10, bit 1) has turned on.

Until Instruction code execution completion turns on after Instruction code execution demand is turned on, do not change the values set in Instruction code and Writing data. Turn off Instruction code execution demand while Instruction code execution completion is on.

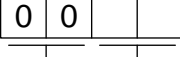
19. EtherNet/IP COMMUNICATION

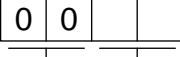
(2) Instruction code

Code No.	Item/function	Writing data content (Master station → Driver)	
		Lower 16 bits	Upper 16 bits
A0XXXXYYh	Writing an object library Writes the value of an object library that can be written when the object library is set as follows: Ins ID is set to XXXX and Attr ID is set to YY. An error code is returned if an object library that cannot be read is specified.	Set the write value for the object library. (Note)	Set the upper 16 bits. (Note)
B0XX0000h	Variable mapping instruction code Changes the reference object of User defined data defined in the variable mapping for the 1st Output data (Instance 150). The characters XX in the instruction code indicate the object to be changed. Refer to section 6.2.4 (2) for details.	WritingData format  Attribute ID Fixed to 0	WritingData format  Instance ID
B1XX0000h	Variable mapping instruction code Changes the reference object of User defined data defined in the variable mapping for the 1st Input map (Instance 100). The characters XX in the instruction code indicate the object to be changed. Refer to section 6.2.4 (2) for details.	WritingData format  Attribute ID Fixed to 0	WritingData format  Instance ID
Note.	If the size of an object to be written is smaller than 32 bits, nothing is written to the remaining areas.		

19. 6. 2. 4 Variable mapping

(1) Timing chart of when variable mapping is used

Set the writing instruction code corresponding to an object to be changed in Instruction code. At this time, set Ins ID and Attr ID of the object in Writing data in hexadecimal. After that, turn on Instruction code execution demand (Control DI 10, bit 1).

When Instruction code execution demand (Control DI 10, bit 1) is turned on, the mapping position for which the object corresponding to the writing instruction code has been defined is handled as the object set in Writing data. After the writing is completed, Instruction code execution completion (Status DO 10, bit 1) turns on.

The following figure shows the reflection timing in the mapping with the variable mapping.

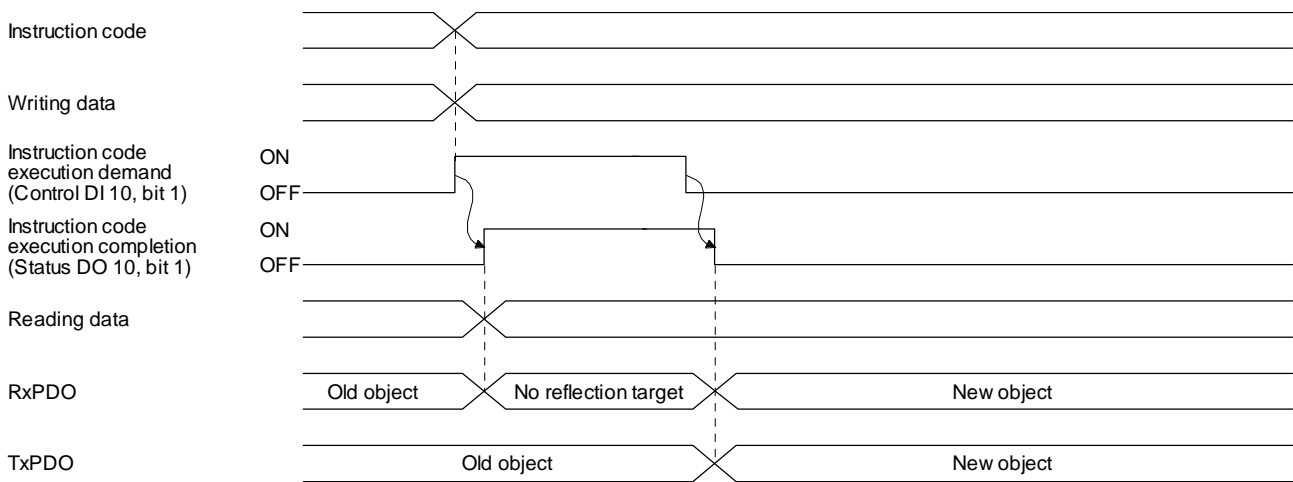

In consideration of the timing above, for data sent by the upper side, the upper side sets new object data in User defined data when the upper side receives the on state of Instruction code execution completion from the driver. After the setting is completed, turn off Instruction code execution demand. When the upper side receives the off state of Instruction code execution completion from the driver, the new object data is applied to User defined data.

User defined data retains the old object data until the upper side receives the off state of Instruction code execution completion. When the upper side receives the off state, the new object data is set in User defined data.

19. EtherNet/IP COMMUNICATION

(2) Variable mapping instruction code

The following table lists the instruction codes and the corresponding instance names in an I/O communication mapping file.

No.	Send direction	Instruction code	Size	Default	Definition in the mapping file
1	Output	B0000000h	2 bytes	Control DI 1 (2D01h)	User defined data 0 (2 bytes)
2	Output	B0010000h	2 bytes	Control DI 2 (2D02h)	User defined data 1 (2 bytes)
3	Output	B0020000h	2 bytes	Control DI 3 (2D03h)	User defined data 2 (2 bytes)
4	Output	B0030000h	4 bytes	Velocity limit value (2D20h)	User defined data 3 (4 bytes)
5	Output	B0040000h	4 bytes		User defined data 4 (4 bytes)
6	Output	B0050000h	4 bytes		User defined data 5 (4 bytes)
7	Output	B0060000h	4 bytes		User defined data 6 (4 bytes)
8	Input	B1000000h	2 bytes	Status DO 1 (2D11h)	User defined data 0 (2 bytes)
9	Input	B1010000h	2 bytes	Status DO 2 (2D12h)	User defined data 1 (2 bytes)
10	Input	B1020000h	2 bytes	Status DO 3 (2D13h)	User defined data 2 (2 bytes)
11	Input	B1030000h	4 bytes	Following error actual value (60F4h)	User defined data 3 (4 bytes)
12	Input	B1040000h	4 bytes	Digital inputs (60FDh)	User defined data 4 (4 bytes)
13	Input	B1050000h	4 bytes		User defined data 5 (4 bytes)
14	Input	B1060000h	4 bytes		User defined data 6 (4 bytes)

(3) Error conditions

The following table lists the conditions for normal completion and errors. The code numbers correspond to the respond codes in section 6.2.5.

Error name	Cause	Code No.
Finished normally	An instance in User defined data has been successfully switched.	0: Normal result
Instruction code error	The instruction code corresponds to High but does not correspond to Low.	1: Code error
Non-existent mapping definition	The specified mapping definition does not exist in the default mapping file definitions.	1: Code error
User defined data error	The specified instance does not exist.	3: Writing data out of range
Send/receive error	The send directions of the instruction code and User defined data are different.	3: Writing data out of range
Data size error	The data size of User defined data has exceeded the data size allowed by the instruction code.	3: Writing data out of range
Assignment error of User defined data 0 to 6	User defined data 0 to 6 have been assigned.	3: Writing data out of range

19.6.2.5 Respond code

When an instruction code set in Instruction code is outside the setting range, an error code is set in Respond code. When the set instruction code is within the setting range, "_ _ 0 _" is set. The value in _ at reading is undefined.



Error of the reading instruction code and writing instruction code

Code No.	Error detail	Details
0	Normal result	The instruction has been completed normally.
1	Code error	An incorrect code No. is specified.
2		
3	Writing data out of range	A value out of the range is set.

19. EtherNet/IP COMMUNICATION

19.6.3 Stroke end

When LSP (Forward rotation stroke end) or LSN (Reverse rotation stroke end) is turned off, a slow stop is performed by either of the following stop methods.

Operation status		Remark
During rotation at constant speed	During deceleration to a stop	
<p> ——— No S-pattern acceleration/ deceleration - - - With S-pattern acceleration/ deceleration </p> <p>Servo motor speed</p> <p>0 r/min (0 mm/s)</p> <p>LSP or LSN</p> <p>ON OFF</p>	<p> ——— No S-pattern acceleration/ deceleration - - - With S-pattern acceleration/ deceleration </p> <p>Servo motor speed</p> <p>0 r/min (0 mm/s)</p> <p>LSP or LSN</p> <p>ON OFF</p>	<p>Travels for the droop pulse portion and stops the servo motor.</p> <p>A difference will be generated between the command position and the current position.</p> <p>Perform a home position return again.</p>

Perform a return as follows when the stroke end is detected.

Mode	Return method
Profile position mode (pp)	Input the position command of the direction opposite to the limit to Target position (607Ah).
Profile velocity mode (pv)	Input the speed command of the direction opposite to the limit to Target velocity (60FFh).

19. EtherNet/IP COMMUNICATION

19.6.4 Definition of alarm-related objects

Whether an alarm occurs or not in the slave (driver) can be detected on the master (upper side) with Bit 3 and Bit 7 of Statusword in the I/O communication. The alarm history of the latest alarm and 15 alarms that have occurred can be referred to by acquiring the following related object values in the Explicit Message communication.

Class ID	Ins ID	Attr ID	Access	Name	Data Type	Description
64h	2A00h	0	Get	Alarm history newest	USINT	Refer to section 7.3.5 (1).
		1	Get	Alarm No.	UDINT	
		2	Get	Alarm time (Hour)	UDINT	
	2A01h	0	Get	Alarm history 1	USINT	Refer to section 7.3.5 (2).
		1	Get	Alarm No.	UDINT	
		2	Get	Alarm time (Hour)	UDINT	
	:	:	:	:	:	
	2A0Fh	0	Get	Alarm history 15	USINT	
		1	Get	Alarm No.	UDINT	
		2	Get	Alarm time (Hour)	UDINT	
	2A40h	0	Set	Clear alarm history	UINT	Refer to section 7.3.5 (3).
	2A41h	0	Get	Current alarm	UDINT	Refer to section 7.3.5 (4).
	2A44h	0	Get	Parameter error number	UINT	Refer to section 7.3.5 (5).
	2A45h	0	Get	Parameter error list	USINT	Refer to section 7.3.5 (6).
		1	Get	(No. 1)	UINT	
:		:	:	:		
16		Get	(No. 16)	UINT		

19. EtherNet/IP COMMUNICATION

19.6.5 Parameter object

19.6.5.1 Definition of parameter objects

The parameter of the driver can be changed on the master (upper side) by writing values to the following objects in the Explicit Message communication. However, once the power supply is shut off, the changed setting is not held at the next startup. To hold the changed setting even after the power supply is shut-off, save the parameter setting value to EEPROM using Store Parameters (Class ID: 64h, Ins ID: 1010h). To change the setting of the parameters where the changes are reflected by cycling the power (parameters whose symbols are preceded by **), change the value of the corresponding object and execute Store Parameters (Class ID: 64h, Ins ID: 1010h) before cycling the power. Refer to chapter 5 of for "*" of the parameter symbol. The following table lists the related objects.

Class ID	Ins ID	Attr ID	Access	Name	Data Type	Description
64h	2001h	0	Get/Set	PA01	DINT	[Pr. PA_ _] group
	:	:	:	:	:	
64h	2020h	0	Get/Set	PA32	DINT	[Pr. PA_ _] group
	:	:	:	:	:	
64h	2081h	0	Get/Set	PB01	DINT	[Pr. PB_ _] group
	:	:	:	:	:	
64h	20C0h	0	Get/Set	PB64	DINT	[Pr. PB_ _] group
	:	:	:	:	:	
64h	2101h	0	Get/Set	PC01	DINT	[Pr. PC_ _] group
	:	:	:	:	:	
64h	2150h	0	Get/Set	PC80	DINT	[Pr. PC_ _] group
	:	:	:	:	:	
64h	2181h	0	Get/Set	PD01	DINT	[Pr. PD_ _] group
	:	:	:	:	:	
64h	21B0h	0	Get/Set	PD48	DINT	[Pr. PD_ _] group
	:	:	:	:	:	
64h	2201h	0	Get/Set	PE01	DINT	[Pr. PE_ _] group
	:	:	:	:	:	
64h	2240h	0	Get/Set	PE64	DINT	[Pr. PE_ _] group
	:	:	:	:	:	
64h	2281h	0	Get/Set	PF01	DINT	[Pr. PF_ _] group
	:	:	:	:	:	
64h	22C0h	0	Get/Set	PF48	DINT	[Pr. PF_ _] group
	:	:	:	:	:	
64h	2401h	0	Get/Set	PL01	DINT	[Pr. PL_ _] group
	:	:	:	:	:	
64h	2430h	0	Get/Set	PL48	DINT	[Pr. PL_ _] group
	:	:	:	:	:	
64h	2481h	0	Get/Set	PT01	DINT	[Pr. PT_ _] group
	:	:	:	:	:	
64h	24D0h	0	Get/Set	PT80	DINT	[Pr. PT_ _] group
	:	:	:	:	:	
64h	2581h	0	Get/Set	PN01	DINT	[Pr. PN_ _] group
	:	:	:	:	:	
64h	25A0h	0	Get/Set	PN32	DINT	[Pr. PN_ _] group
	:	:	:	:	:	

19. EtherNet/IP COMMUNICATION

19.6.5.2 Enabling parameters

The parameters whose symbols are preceded by "*" are enabled by the following operations. Refer to chapter 5 in for the parameters with "*". Refer to chapter 5 for "*" of the parameter symbol.

(1) Network disconnection

A parameter is enabled when a network disconnection switches the driver state to the state in which it waits for the upper side to be connected. Refer to section 1.4.3 for the procedure of network disconnection.

(2) State transition

A parameter is enabled when the I/O connection shifts from the Run mode to another mode.

(3) Enabling a parameter with a parameter enabling object

A parameter is enabled by writing "1EA5h" in User parameter configuration (Class ID: 64h, Ins ID: 2D34h, Attr ID: 0). This operation can be performed only when the I/O connection is not in the Run mode. The parameter enabling processing requires a maximum of about 100 ms. The following table shows the read values of User parameter configuration (Class ID: 64h, Ins ID: 2D34h, Attr ID: 0). By checking the read value, the completion of the parameter enabling processing can be checked.

Value	Description
0	Parameter enabling processing is being executed.
1	Parameter enabling processing is not being executed. (The processing is completed.)

19. EtherNet/IP COMMUNICATION

19.6.6 One-touch tuning

Refer to section 6.2 of for one-touch tuning. Using One-touch tuning mode (Class ID: 64h, Ins ID: 2D50h, Attr ID: 0) allows one-touch tuning from a upper side.

(1) Related object

Class ID	Ins ID	Attr ID	Access	Name	Data Type	Default	Description
64h	2D50h	0	Get/Set	One-touch tuning mode	USINT	0	One-touch tuning command Setting a value of "1" to "3" starts one-touch tuning. After one-touch tuning is completed, the setting value automatically changes to "0". 0: During one-touch tuning stop 1: Basic mode 2: High mode 3: Low mode
	2D51h	0	Get	One-touch tuning status	SINT	0	One-touch tuning status Regardless of whether one-touch tuning is properly completed or not, the setting value changes to 100% at the completion. Unit: %
	2D52h	0	Set	One-touch tuning Stop	UINT	0	One-touch tuning stop command Writing "1EA5h" stops one-touch tuning. Writing a value other than "1EA5h" sets General status code 09h Invalid attribute value.
	2D53h	0	Set	One-touch tuning Clear	UINT	0	The parameter changed in one-touch tuning can be returned to the value before the change. 0000h: Restores the initial value. 0001h: Restores the value before one-touch tuning. The setting value of the restored parameter is stored to the EEPROM.
	2D54h	0	Get	One-touch tuning Error Code	UINT	0	One-touch tuning error code 0000h: Finished normally C000h: Tuning canceled C001h: Overshoot exceeded C002h: Servo-off during tuning C003h: Control mode error C004h: Time-out C005h: Load to motor inertia ratio misestimated C00Fh: One-touch tuning disabled

(2) Procedure of one-touch tuning via a network

Perform one-touch tuning via a network in the following procedure.

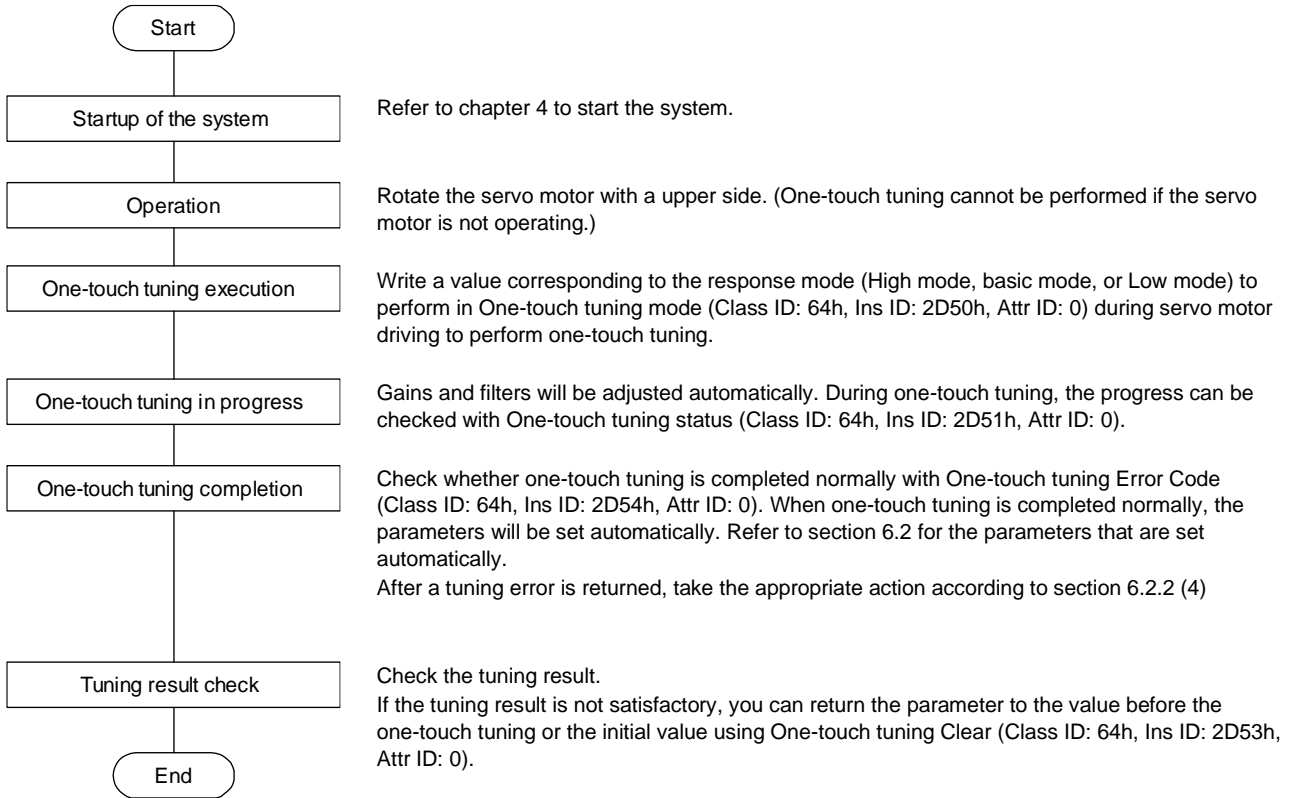

19. EtherNet/IP COMMUNICATION

19.6.7 Machine diagnosis function

This function estimates the friction and vibrational component of the drive system in the equipment based on the data in the driver, and recognizes an error in the machine parts, including a ball screw and bearing. The information of the machine diagnosis function can be obtained with the following objects.

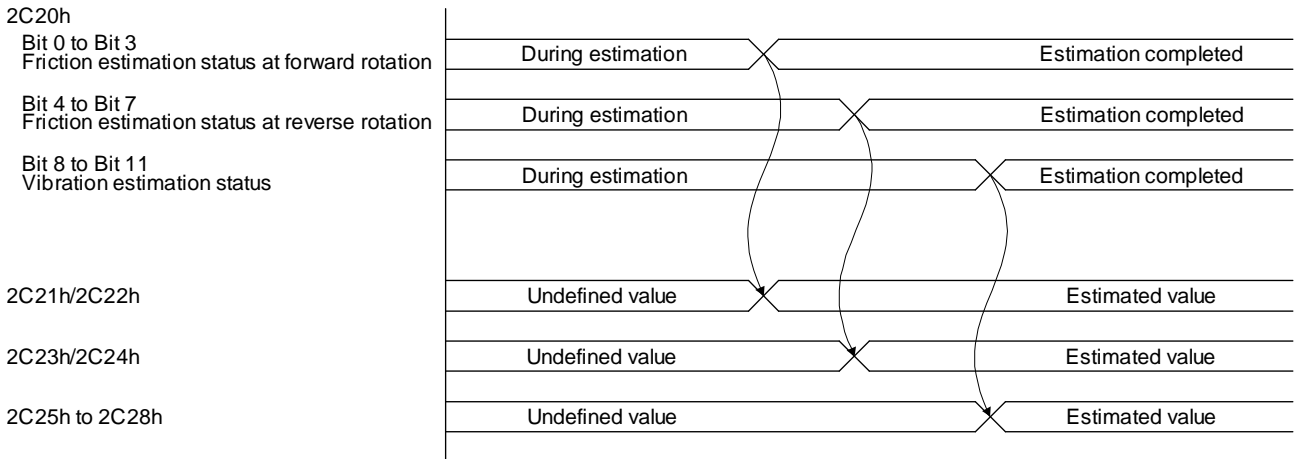

Class ID	Ins ID	Attr ID	Access	Name	Data Type	Default	Description
64h	2C20h	0	Get	Machine diagnostic status	UINT		Machine diagnostic status Refer to section 7.3.7 (4).
	2C21h	0	Get	Static friction torque at forward rotation	INT		Static friction torque at forward rotation Static friction torque at forward rotation is returned in increments of 0.1%.
	2C22h	0	Get	Dynamic friction torque at forward rotation (at rated speed)	INT		Dynamic friction torque at forward rotation (at rated speed) Dynamic friction torque at forward rotation at the rated speed is returned in increments of 0.1%.
	2C23h	0	Get	Static friction torque at reverse rotation	INT		Static friction torque at reverse rotation Static friction torque at reverse rotation is returned in increments of 0.1%.
	2C24h	0	Get	Dynamic friction torque at reverse rotation (at rated speed)	INT		Dynamic friction torque at reverse rotation (at rated speed) Dynamic friction torque at reverse rotation at rated speed is returned in increments of 0.1%.
	2C25h	0	Get	Oscillation frequency during motor stop	INT		Vibration frequency at stop/servo-lock Vibration frequency during stop/servo-lock is displayed in increments of 1 Hz.
	2C26h	0	Get	Vibration level during motor stop	INT		Vibration level at stop/servo-lock Vibration level during stop/servo-lock is displayed in increments of 0.1%.
	2C27h	0	Get	Oscillation frequency during motor operating	INT		Vibration frequency during operation Vibration frequency during operation is displayed in increments of 1 Hz.
	2C28h	0	Get	Vibration level during motor operating	INT		Vibration level during operation Vibration level during operation is displayed in increments of 0.1%.

19. EtherNet/IP COMMUNICATION

19.6.8 Driver life diagnosis function

You can check the cumulative energization time and the number of on/off times of the inrush relay based on the data in the driver. This function gives an indication of the replacement time for parts of the driver including a capacitor and a relay before they malfunction. The information of the driver life diagnosis function can be obtained with the following objects.

Class ID	Ins ID	Attr ID	Access	Name	Data Type	Default	Description
64h	2C18h	0	Get	Power ON cumulative time	UDINT		The cumulative energization time of the driver is returned.
	2C19h	0	Get	Number of inrush relay on/off times	UDINT		The number of on/off times of the inrush relay of the driver is returned.

19.6.9 Positioning function by operation start-up signal

POINT
<ul style="list-style-type: none"> ● The positioning function by the operation start-up signal can be used in the profile position mode.

19.6.9.1 Summary

The positioning function by the operation start-up signal performs positioning operations using external input signals. Turning on Operation start-up signal activation (C_OSSA) in the profile position mode (pp) starts positioning operations using external input signals.

Because positioning operations start using external input signals of the driver, an operation can be started without delay at the start due to a communication delay.

19.6.9.2 Specification list

Item	Description
Supported control mode	Profile position mode
Supported operation mode	Standard control mode, fully closed loop control mode, linear servo motor control mode, DD motor control mode
Operation pattern	Single (A positioning operation is performed at the rising edge of an external input signal.)
Command generation pattern	A command pattern is calculated from the acceleration time and deceleration time.
Supported communication	EtherNet/IP

19.6.9.3 Settings

(1) List of items set with parameters of the driver

Setting item	Setting parameter	Setting
Operation start-up signal assignment	PD38	Set [Pr. PD38] to "_ _ 2 E" and assign ST (operation start-up) to an external input signal. If Operation start-up signal activation (C_OSSA) is turned on without ST assigned, Operation error (S_OERR) turns on.
S-pattern acceleration/deceleration time constant	PT51	Set the time of the arc part for S-pattern acceleration/deceleration. Setting "0" will make it linear acceleration/deceleration.
Maximum profile speed	PT66	Set the maximum value of the target speed for the positioning operation. This parameter can be set by inputting a value in Max profile velocity (Class ID: 64h, Ins ID: 607Fh, Attr ID: 0).
Profile speed command	PT65	Set the target speed for the positioning operation. This parameter can be set by inputting a value in Profile velocity (Class ID: 64h, Ins ID: 6081h, Attr ID: 0).
Acceleration time constant	PT49	Set the acceleration time taken for the servo motor that has stopped to reach the rated speed in the positioning operation. This parameter can be set by inputting a value in Profile acceleration (Class ID: 64h, Ins ID: 6083h, Attr ID: 0).
Deceleration time constant	PT50	Set the deceleration time taken for the servo motor that is operating at the rated speed to stop in the positioning operation. This parameter can be set by inputting a value in Profile deceleration (Class ID: 64h, Ins ID: 6084h, Attr ID: 0).

(2) List of items set in the network communication

Setting item	Object (Class ID, Ins ID, Attr ID)	Bit	Setting
Control mode	Modes of operation (64h, 6060h, 0)		Set "1" in Modes of operation to change the control mode to the profile position mode.
Positioning mode setting	Controlword (64h, 6040h, 0)	Bit 5 Bit 9	Set the positioning mode. The positioning mode is determined by a combination of values of bit 5 and bit 9 of Controlword. Refer to section 5.4.3 for details.
Target position	Target position (64h, 607Ah, 0)		Set a target position. The command used for the target position can be changed between the absolute position command and relative position command using bit 6 of Controlword. When the unit is set to degree, relative position commands are disabled. When the relative position command is specified and positioning is started, [AL. F4.8] occurs and positioning cannot be started. If positioning is attempted with a set target position outside the following setting range, [AL. F4.4] occurs and the positioning cannot be started. pulse: -999999 to 999999 degree: -360000 to 360000
Target speed	Profile velocity (64h, 6081h, 0)		Set a target speed. This value is clamped at the speed set with Max profile velocity (64h, 607Fh, 0) or the instantaneous permissible speed of the servo motor used.
Acceleration time constant	Profile acceleration (64h, 6083h, 0)		Set the acceleration time taken for the servo motor that has stopped to reach the rated speed. If positioning is attempted with a time longer than 20000 ms set, [AL. F4.6] occurs and the positioning cannot be started.
Deceleration time constant	Profile deceleration (64h, 6084h, 0)		Set the deceleration time for the servo motor to stop from the rated speed. If positioning is attempted with a time longer than 20000 ms set, [AL. F4.7] occurs and the positioning cannot be started.
Operation start-up signal activation (C_OSSA)	Control DI 10 (64h, 2D0Ah, 0)	Bit 2	Turn on Operation start-up signal activation (C_OSSA). If Operation start-up signal activation (C_OSSA) is turned on without ST (operation start-up) assigned to an external input signal, Operation error (S_OERR) turns on.

19. 6. 9. 4 Status obtainable in the network communication

The following table shows the specific status that can be obtained in the network communication during positioning operation by an operation start-up signal. The status that can be obtained in the profile position mode can be obtained. Refer to section 5.3 for details.

Status	Description
Operation error (S_OERR)	Indicates that an error has occurred in a positioning operation started by the operation start-up signal. The status can be obtained with bit 2 of Status DO 10. Off: Normal On: Error

19. EtherNet/IP COMMUNICATION

19.6.9.5 Operation method

(1) Procedure

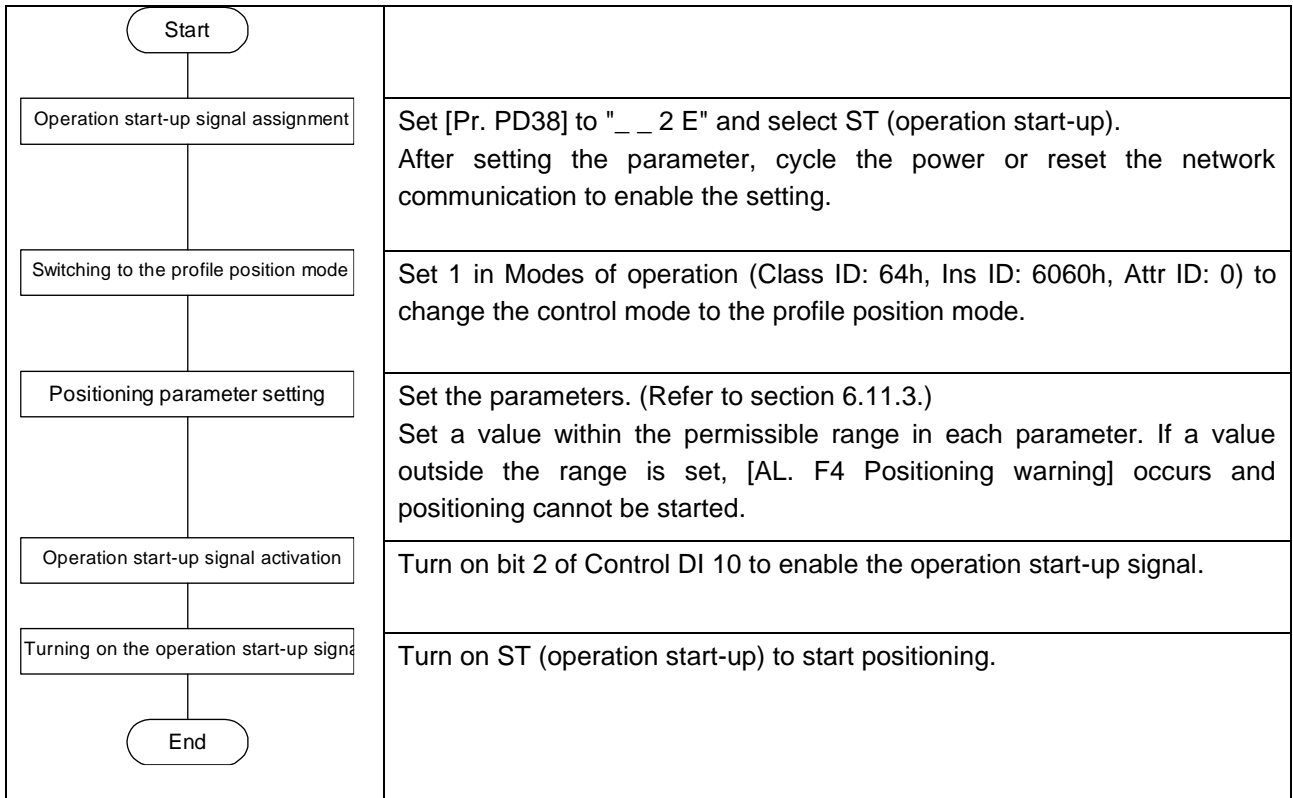

(2) Timing chart

The following shows a timing chart of the positioning function by the operation start-up signal. The positioning operation can be started by enabling the operation start-up signal and turning on ST (operation start-up).

Note that the positioning operation by the operation start-up signal cannot be started even though the operation start-up signal is enabled during positioning operation with the network communication. The positioning operation with the network communication cannot be started even though the operation start-up signal is disabled and the start-up signal is input with the network communication during positioning operation by the operation start-up signal.

Switching of the network communication and the operation start-up signal can be executed only when a positioning is completed. Completion of a positioning can be checked with Target reached (Statusword bit 10).

(a) Positioning by operation start-up signal

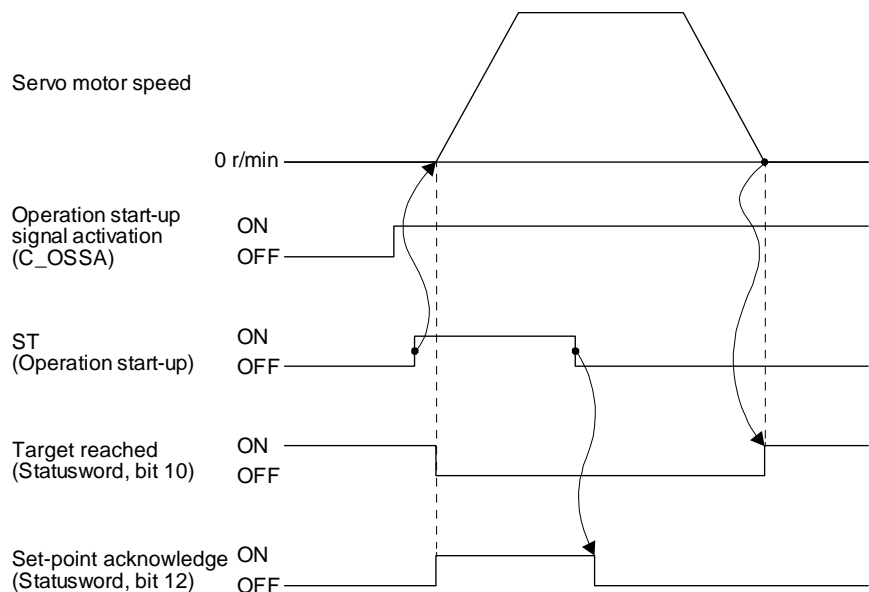

(b) Switching of positioning by the network communication and positioning by the operation start-up signal

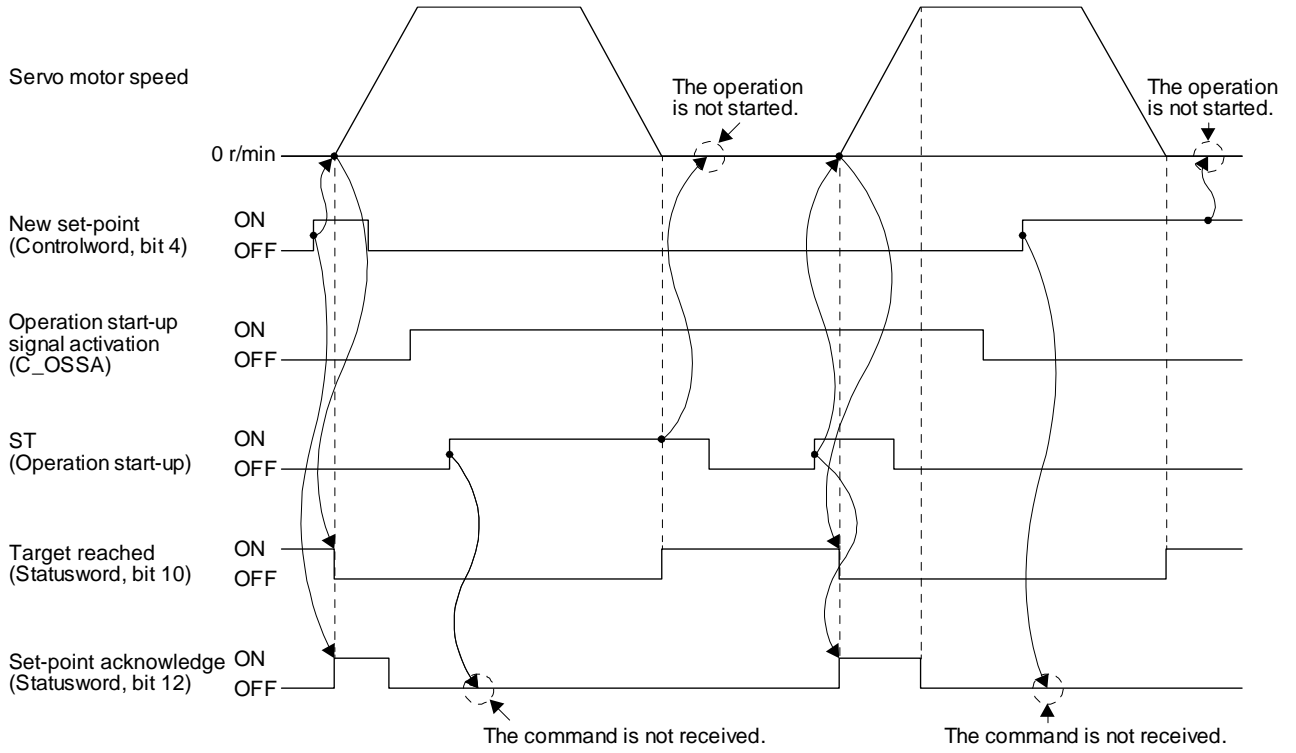

19. EtherNet/IP COMMUNICATION

19.7 OBJECT LIBRARY

19.7.1 Store Parameters

POINT
<p>● Before shutting off the power after executing Store Parameters, always check that parameters are not being saved (bit 0 is on).</p>

Writing "65766173h" (= reverse order of the ASCII code of "save") to the corresponding sub object of Store Parameters (Class ID: 64h, Ins ID: 1010h) stores objects in the EEPROM of the driver.

The value saved in the EEPROM is set to the object at the next power-on. Servo parameters can also be modified through the object library. However, the new setting is not automatically written to the EEPROM. To write the new setting, use Store Parameters (Class ID: 64h, Ins ID: 1010h).

Executing Store Parameters (Class ID: 64h, Ins ID: 1010h) takes about a maximum of 25 s because all parameters are written at the same time. Be careful not to shut off the power during writing.

Class ID	Ins ID	Attr ID	Access	Name	Data Type	Description
64h	1010h	0	Get	Store Parameters	USINT	Number of entries
		1	Get/Set	Save all parameters	UDINT	Saves all parameters. Writing "save" (= 65766173h) saves all the objects which can be stored in the EEPROM.
		2 (Not supported) (Note)	Get/Set	Save communication parameters	UDINT	Saves communication parameters. Writing "save" (= 65766173h) saves the communication objects (except Class ID 64h) in the EEPROM.
		3 (Not supported) (Note)	Get/Set	Save application parameters	UDINT	Saves application parameters. Writing "save" (= 65766173h) saves the Class ID 64h objects which can be stored in the EEPROM.

Note. This is not supported by the driver.

The following values are read from this object. When a parameter is being saved, "0" is read. When no parameter is being saved, "1" is read.

Bit	Description
0	0: The parameter cannot be saved with the command. (A parameter is being saved.) 1: The parameter can be saved with the command. (No parameter is being saved.)
1	0: The parameter is not automatically saved.

19. EtherNet/IP COMMUNICATION

19.7.2 Supported object library list

Group	Name	Class ID	Instance ID
General Objects	Identity Object	01h	
	Store parameters	64h	1010h
Communication Setting Objects	Message Router Object	02h	
	Connection Manager Object	06h	
	Device Level Ring(DLR) Object	47h	
	QoS Object	48h	
	TCP/IP Interface Object	F5h	
	Ethernet Link Object	F6h	
Assembly Objects	Assembly Object	04h	
Parameter Objects	PA_ _	64h	2001h to 2020h
	PB_ _		2081h to 20C0h
	PC_ _		2101h to 2150h
	PD_ _		2181h to 21B0h
	PE_ _		2201h to 2240h
	PF_ _		2281h to 22C0h
	PL_ _		2401h to 2430h
	PT_ _		2481h to 24D0h
	PN_ _		2581h to 25A0h
Alarm Objects	Alarm history newest	64h	2A00h
	Alarm history _		2A01h to 2A0Fh
	Clear alarm history		2A40h
	Current alarm		2A41h
	Parameter error number		2A44h
	Parameter error list		2A45h
Monitor Objects	Cumulative feedback pulses	64h	2B01h
	Servo motor speed		2B02h
	Droop pulses		2B03h
	Cumulative command pulses		2B04h
	Command pulse frequency		2B05h
	Regenerative load ratio		2B08h
	Effective load ratio		2B09h
	Peak load ratio		2B0Ah
	Instantaneous torque		2B0Bh
	Within one-revolution position		2B0Ch
	ABS counter		2B0Dh
	Load to motor inertia ratio		2B0Eh
	Bus voltage		2B0Fh
	Load-side cumulative feedback pulses		2B10h
	Load-side droop pulses		2B11h
	Load-side encoder information 1 Z-phase counter		2B12h
	Load-side encoder information 2		2B13h
	Temperature of motor thermistor		2B17h
	Motor-side cumu. feedback pulses (before gear)		2B18h
	Electrical angle		2B19h
	Motor-side/load-side position deviation		2B23h
	Motor-side/load-side speed deviation		2B24h
	Internal temperature of encoder		2B25h
	Settling time		2B26h
	Oscillation detection frequency		2B27h
	Number of tough drive operations		2B28h
	Unit power consumption		2B2Dh
	Unit total power consumption		2B2Eh
	Alarm Monitor 1 Cumulative feedback pulses		2B81h

19. EtherNet/IP COMMUNICATION

Group	Name	Class ID	Instance ID
Monitor Objects	Alarm Monitor 2 Servo motor speed	64h	2B82h
	Alarm Monitor 3 Droop pulses		2B83h
	Alarm Monitor 4 Cumulative command pulses		2B84h
	Alarm Monitor 5 Command pulse frequency		2B85h
	Alarm Monitor 8 Regenerative load ratio		2B88h
	Alarm Monitor 9 Effective load ratio		2B89h
	Alarm Monitor 10 Peak load ratio		2B8Ah
	Alarm Monitor 11 Instantaneous torque		2B8Bh
	Alarm Monitor 12 Within one-revolution position		2B8Ch
	Alarm Monitor 13 ABS counter		2B8Dh
	Alarm Monitor 14 Load to motor inertia ratio		2B8Eh
	Alarm Monitor 15 Bus voltage		2B8Fh
	Alarm Monitor 16 Load-side cumulative feedback pulses		2B90h
	Alarm Monitor 17 Load-side droop pulses		2B91h
	Alarm Monitor 18 Load-side encoder information 1 Z-phase counter		2B92h
	Alarm Monitor 19 Load-side encoder information 2		2B93h
	Alarm Monitor 23 Temperature of motor thermistor		2B97h
	Alarm Monitor 24 Motor-side cumu. feedback pulses (before gear)		2B98h
	Alarm Monitor 25 Electrical angle		2B99h
	Alarm Monitor 35 Motor-side/load-side position deviation		2BA3h
	Alarm Monitor 36 Motor-side/load-side speed deviation		2BA4h
	Alarm Monitor 37 Internal temperature of encoder		2BA5h
	Alarm Monitor 38 Settling time		2BA6h
	Alarm Monitor 39 Oscillation detection frequency		2BA7h
	Alarm Monitor 40 Number of tough drive operations		2BA8h
	Alarm Monitor 45 Unit power consumption		2BADh
Alarm Monitor 46 Unit total power consumption	2BAEh		
Manufacturer Specific Control Objects	External Output pin display	64h	2C11h
	Power ON cumulative time		2C18h
	Number of inrush relay on/off times		2C19h
	Machine diagnostic status		2C20h
	Static friction torque at forward rotation		2C21h
	Dynamic friction torque at forward rotation (at rated speed)		2C22h
	Static friction torque at reverse rotation		2C23h
	Dynamic friction torque at reverse rotation (at rated speed)		2C24h
	Oscillation frequency during motor stop		2C25h
	Vibration level during motor stop		2C26h
	Oscillation frequency during motor operating		2C27h
	Vibration level during motor operating		2C28h
	Control DI 1		2D01h
	Control DI 2		2D02h
	Control DI 3		2D03h
	Control DI 7		2D07h
	Control DI 10		2D0Ah
	Status DO 1		2D11h
	Status DO 2		2D12h
	Status DO 3		2D13h
	Status DO 5		2D15h
	Status DO 6		2D16h
	Status DO 7		2D17h

19. EtherNet/IP COMMUNICATION

Group	Name	Class ID	Instance ID
Manufacturer Specific Control Objects	Status DO 10	64h	2D1Ah
	Velocity limit value		2D20h
	Motor rated speed		2D28h
	Manufacturer Device Name 2		2D30h
	Manufacturer Hardware Version 2		2D31h
	Manufacturer Software Version 2		2D32h
	Serial Number 2		2D33h
	User parameter configuration		2D34h
	Encoder status		2D35h
	Scale cycle counter		2D36h
	Scale ABS counter		2D37h
	Scale measurement encoder resolution		2D38h
	Scale measurement encoder reception status		2D3Ch
	One-touch tuning mode		2D50h
	One-touch tuning status		2D51h
	One-touch tuning Stop		2D52h
	One-touch tuning Clear		2D53h
One-touch tuning Error Code	2D54h		
PDS Control Objects	Error code	64h	603Fh
	Controlword		6040h
	Statusword		6041h
	Quick stop option code		605Ah
	Halt option code		605Dh
	Modes of operation		6060h
	Modes of operation display		6061h
	Supported drive modes		6502h
Position Control Function Objects	Position actual internal value	64h	6063h
	Position actual value		6064h
	Following error window		6065h
	Following error time out		6066h
	Position window		6067h
	Position window time		6068h
	Positioning option code		60F2h
	Following error actual value		60F4h
	Control effort		60FAh
Profile Velocity Mode Objects	Velocity demand value	64h	606Bh
	Velocity actual value		606Ch
	Velocity window		606Dh
	Velocity window time		606Eh
	Velocity threshold		606Fh
	Velocity threshold time		6070h
	Target velocity		60FFh
Profile Torque Mode Objects	Target torque	64h	6071h
	Max torque		6072h
	Torque demand value		6074h
	Torque actual value		6077h
	Torque slope		6087h
	Torque profile type		6088h
	Positive torque limit value		60E0h
	Negative torque limit value		60E1h
Profile Position Mode Objects	Target position	64h	607Ah
	Position range limit		607Bh
	Software position limit		607Dh
	Max profile velocity		607Fh
	Max motor speed		6080h
	Profile velocity		6081h

19. EtherNet/IP COMMUNICATION

Group	Name	Class ID	Instance ID
Profile Position Mode Objects	Profile acceleration	64h	6083h
	Profile deceleration		6084h
	Quick stop deceleration		6085h
	Motion profile type		6086h
	External encoder gear ratio		2DF0h
	External encoder acceleration		2DF1h
	External encoder deceleration		2DF2h
Homing Mode Objects	Home offset	64h	607Ch
	Homing method		6098h
	Homing speeds		6099h
	Homing acceleration		609Ah
	Supported homing method		60E3h
Factor Group Objects	Polarity	64h	607Eh
	Position encoder resolution		608Fh
	Gear ratio		6091h
	Feed constant		6092h
	SI unit position		60A8h
	SI unit velocity		60A9h
Touch Probe Function Objects	Touch probe function	64h	60B8h
	Touch probe status		60B9h
	Touch probe pos1 pos value		60BAh
	Touch probe pos1 neg value		60BBh
	Touch probe pos2 pos value		60BCh
	Touch probe pos2 neg value		60BDh
Optional application FE Objects	Digital inputs	64h	60FDh
	Digital outputs		60FEh

19.7.3 Object library

This section describes the details of the object library for each group.

The following is shown in the "Access" column.

"Get": Only reading is available.

"Set": Only writing is available.

"Get/Set": Reading and writing are available.

The following is shown in the "EEP-ROM" column.

"Impossible": The data is not saved to the EEP-ROM. The value of the data written from the upper side returns to the value of "Default" when the power is shut off.

"Possible": The data can be saved to the EEP-ROM with Store Parameters (Class ID: 64h, Ins ID: 1010h). The data is saved in the parameter corresponding to the object. For the corresponding parameters, refer to "Parameter".

19. EtherNet/IP COMMUNICATION

19.7.3.1 General Objects

(1) Identity Object (Class ID: 01h)

Ins ID	Attr ID	Access	Name	Data Type	
0	1	Get	Revision	UINT	
	2	Get	Max Instance	UINT	
	3	Get	Number of Instances	UINT	
1	1	Get	Vendor ID	UINT	
	2	Get	Device Type	UINT	
	3	Get	Product Code	UINT	
	4	Get	Revision	Structure including the following	
			Major Revision		USINT
			Minor Revision		USINT
	5	Get	Status	WORD	
	6	Get	Serial Number	UDINT	
	7	Get	Product Name	SHORT_STRING	
	11	Set	Active Language	Structure including the following	
				USINT	
				USINT	
12	Get	Supported Language List	Structure array including the following		
			USINT		
			USINT		

Ins ID	Attr ID	Default	Range	Units	EEP-ROM	Parameter
0	1	0001	0001h to 0001h		Impossible	
	2	1	0001h to 0001h			
	3	1	0001h to 0001h			
1	1	A1h (161)	00A1h to 00A1h			
	2	002Bh (Generic)	002Bh to 002Bh			
	3	0012h	0012h to 0012h			
	4	____h	0000h to FFFFh			
	5		0000h to 0F75h			
	6	_____h	00000000h to FFFFFFFFh			
	7	HMS -oTM				
	11	eng (English)				
	12	eng (English)				

19. EtherNet/IP COMMUNICATION

General-purpose information, such as device identification information including Vendor ID and device status, is returned. The description of each Attribute is as follows.

Ins ID	Attr ID	Description	
0	1	Revision of this object	
	2	Maximum Instance number	
	3	Number of Instances	
1	1	Identification number of each vendor	
	2	Device type of the product	
	3	Product code assigned by each vendor	
	4	Revision of the item indicated by Identity Object	
		Major revision number (lower 8 bits)	
		Minor revision number (upper 8 bits)	
	5	Summary of the device status Refer to the following table for details.	
	6	Serial number of the device (The serial number of the EtherNet/IP network card is returned.)	
	7	Product name	
	11	Language currently used in the device The language to be used and supported language are stored as follows. For eng (English): language1: 65h (e), language2: 6Eh (n), language3: 67h (g)	
		language1 field of the STRINGI data type	
		language2 field of the STRINGI data type	
		language3 field of the STRINGI data type	
		List of languages supported by the STRINGI data type character string in the device The language to be used and supported language are stored as follows. For eng (English): language1: 65h (e), language2: 6Eh (n), language3: 67h (g)	
		language1 field of the STRINGI data type	
12	language2 field of the STRINGI data type		
	language3 field of the STRINGI data type		

The following table describes Attribute5 (Status) of Class 01h Instance 1.

bit	Name
0	Card Owned
1	Reserved
2	Configured
3	Reserved
4 to 7	Extended Device Status 0000b: Unknown 0010b: Faulted I/O Connection 0011b: No I/O connection establish 0100b: Non volatile configuration bad 0101b: Major fault 0110b: Connection in Run mode 0111b: Connection in Idle mode
8	Minor Recoverable Fault (Note)
9	Minor Unrecoverable Fault (Note)
10	Major Recoverable Fault (Note)
11	Major Unrecoverable Fault (Note)
12 to 15	Reserved

Note. If an alarm occurs, Major Recoverable Fault is returned. If a warning occurs, the status does not change.

19. EtherNet/IP COMMUNICATION

This instance supports the following services.

(a) When Ins ID is 0

Service Code	Name	Description
01h	Get_Attributes_All	Reads the values of all the attributes.
0Eh	Get_Attribute_Single	Reads the value of the specified attribute.

(b) When Ins ID is not 0

Service Code	Name	Description
01h	Get_Attributes_All	Reads the values of all the attributes.
05h	Reset	Calls the Reset service of the specified class/object.
0Eh	Get_Attribute_Single	Reads the value of the specified attribute.
10h	Set_Attribute_Single	Writes a value to the specified attribute.

(c) Reset

POINT
<p>● If the value of the reset type is set to "0" in the Reset service, parameter settings, etc. are still written to the EEP-ROM. Note that the number of write times to the EEP-ROM is limited to 100,000. If the total number of write times exceeds 100,000, the driver may malfunction when the EEP-ROM reaches the end of its useful life.</p>

The following table lists the reset types that can be used with the Reset service.

Value	Reset type
0	Emulate as closely as possible cycling power on the item the Identity Object represents. This value is the default if this parameter is omitted. The network card, driver and MR-D30 functional safety unit do not restore the default values of each parameter.
1	Return as closely as possible to the factory default configuration, then emulate cycling power as closely as possible. The network card restores the default values of communication setting, such as an IP address. The parameters of the driver and MR-D30 functional safety unit are reset to the factory setting.

The following set values of the driver can be rewritten with the factory setting.

- Basic setting parameters ([Pr. PA_ _])
- Gain/filter setting parameters ([Pr. PB_ _])
- Extension setting parameters ([Pr. PC_ _]) (except [Pr. PC11] and [Pr. PC12])
- I/O setting parameters ([Pr. PD_ _])
- Extension setting 2 parameters ([Pr. PE_ _])
- Extension setting 3 parameters ([Pr. PF_ _])
- Linear servo motor/DD motor setting parameters ([Pr. PL_ _])
- Positioning control parameters ([Pr. PT_ _])
- Network setting parameters ([Pr. PN_ _])

19. EtherNet/IP COMMUNICATION

(2) Store parameters (Instance ID: 1010h) (Class ID 64h: Drive Configuration Object)

Ins ID	Attr ID	Access	Name	Data Type
1010h	0	Get	Store parameters	USINT
	1	Get/Set	Save all parameters	UDINT
	2 (Not supported) (Note)		Save communication parameters	
	3 (Not supported) (Note)		Save application parameters	

Ins ID	Attr ID	Default	Range	Units	EEP-ROM	Parameter
1010h	0	3	03h	/	Impossible	/
	1	00000001h	Refer to the following table.			
	2 (Not supported) (Note)					
	3 (Not supported) (Note)					

Note. This is not supported by the driver.

Writing "65766173h" (= reverse order of ASCII code of "save") to the corresponding sub object saves an object value in EEPROM. The relationship between Attribute ID and the saved object is shown below.

Attr ID	Saved object
1	All objects

Whether saving a parameter has been completed can be checked by reading this object. The read values are as follows.

bit	Description
0	0: The parameter cannot be saved with the command. (A parameter is being saved.) 1: The parameter can be saved with the command. (No parameter is being saved.)
1	0: The parameter is not automatically saved.
2 to 31	Unused

This instance supports the following services.

Service Code	Name	Description
0Eh	Get_Attribute_Single	Reads the value of the specified attribute.
10h	Set_Attribute_Single	Writes a value to the specified attribute.

19. EtherNet/IP COMMUNICATION

19.7.3.2 Communication Setting Objects

(1) Message Router object (Class ID: 02h)

This object distributes messages to object classes or object instances in a driver. No attribute or service can be used with this object.

(2) Connection Manager Object (Class ID: 06h)

Ins ID	Attr ID	Access	Name	Data Type
1	1	Set	Open Requests	UINT
	2		Open Format Rejects	
	3		Open Resource Rejects	
	4		Open Other Rejects	
	5		Close Requests	
	6		Close Format Rejects	
	7		Close Other Rejects	
	8		Connection Timeouts	

Ins ID	Attr ID	Default	Range	Units	EEP-ROM	Parameter
1	1	0	0000h to FFFFh	number of times	Impossible	
	2	0				
	3	0				
	4	0				
	5	0				
	6	0				
	7	0				
	8	0				

This object is used to establish an I/O connection or a dedicated connection when Explicit Message is frequently used. The description of each Attribute is as follows.

Ins ID	Attr ID	Description
1	1	Number of Forward_Open service requests received
	2	Number of Forward_Open service requests that have been rejected due to the incorrect format
	3	Number of Forward_Open service requests that have been rejected due to insufficient resource
	4	Number of Forward_Open service requests that have been rejected due to a reason other than the incorrect format or insufficient resource
	5	Number of Forward_Close service requests received
	6	Number of Forward_Close service requests that have been rejected due to the incorrect format
	7	Number of Forward_Close service requests that have been rejected due to a reason other than the incorrect format
	8	Total number of connection time-outs that have occurred in the connection controlled by this Connection Manager

This instance supports the following services.

Service Code	Name	Description
01h	Get_Attributes_All	Reads the values of all the attributes.
0Eh	Get_Attribute_Single	Reads the value of the specified attribute.
10h	Set_Attribute_Single	Writes a value to the specified attribute.
4Eh	Forward_Close	Closes the connection.
54h	Forward_Open	Opens a connection with data size of up to input 509 bytes and output 505 bytes.
5Bh	Large_Forward_Open	Opens a connection with data size of up to 1448 bytes.

19. EtherNet/IP COMMUNICATION

(3) Device Level Ring(DLR) Object (Class ID: 47h)

Ins ID	Attr ID	Access	Name	Data Type
0	1	Get	Revision	UINT
1	1		Network Topology	USINT
	2		Network Status	
	10		Active Supervisor Address	Following structure
			Supervisor IP Address	UDINT
			Supervisor MAC Address	USINT array
12	Capability Flags		DWORD	

Ins ID	Attr ID	Default	Range	Units	EEP-ROM	Parameter
0	1	0003h	0003h to 0003h		Impossible	
1	1	0: Linear 1: Ring	00h to 01h			
	2	0	00h to 1Fh			
	10					
	12	82h (Beacon-based Ring Node, Flush_Table frame capable)	00000000h to 000000E3h			

This object provides an interface of the DLR protocol setting or status information. The description of each Attribute is as follows.

Ins ID	Attr ID	Description	
0	1	Revision of this object	
1	1	Current network topology	
	2	Current network status	
	10	Either or both of the IP address (IPv4) or/and MAC address of an active ring supervisor	
		IP address (IPv4) of an active ring supervisor	
		MAC address of an active ring supervisor	
12	Description of the DLR function of a device Refer to the following table for details.		

Network Status

Network Status value	Description
0	Indicates a normal communication in the Ring or Linear network topology mode.
1	Ring Fault (only when the Ring network topology mode is used)
2	Indicates that an unexpected loop has been detected in the network (only when the Linear network topology mode is used).
3	Partial Network Fault (only when the Ring network topology mode is used and the node is a Ring supervisor)
4	Rapid Fault/Restore Cycle

Capability Flags

bit	Called	Definition
0	Announce-based Ring Node	Set when the ring node of the device is based on the Announce frame.
1	Beacon-based Ring Node	Set when the ring node of the device is based on the Beacon frame.
2 to 4	Reserved	Reserved
5	Supervisor Capable	Set when the device can provide a supervisor function.
6	Redundant Gateway Capable	Set when the device can provide a redundant gateway function.
7	Flush_Table frame Capable	Set when Flush Tables flames can be supported.
8 to 31	Reserved	Reserved

19. EtherNet/IP COMMUNICATION

This instance supports the following services.

(a) When Ins ID is 0

Service Code	Name	Description
01h	Get_Attributes_All	Reads the values of all the attributes.
0Eh	Get_Attribute_Single	Reads the value of the specified attribute.

(b) When Ins ID is not 0

Service Code	Name	Description
0Eh	Get_Attribute_Single	Reads the value of the specified attribute.

(4) QoS Object (Class ID: 48h)

Ins ID	Attr ID	Access	Name	Data Type
0	1	Get	Revision	UINT
1	1	Set	802.1Q Tag Enable	USINT
	4		DSCP Urgent	
	5		DSCP Scheduled	
	6		DSCP High	
	7		DSCP Low	
	8		DSCP Explicit	

Ins ID	Attr ID	Default	Range	Units	EEP-ROM	Parameter
0	1	0001h	00h to FFh		Impossible	
1	1	0				
	4	55				
	5	47				
	6	43				
	7	31				
	8	27				

This object sets priority on communication basis to prevent a communication delay or stop due to a heavy band. The description of each Attribute is as follows.

Ins ID	Attr ID	Description
0	1	Revision of this object
1	1	Enable or disable 802.1Q frame transmission on CIP and IEEE1588.
	4	DSCP value for urgent messages of the CIP transport class 0/1
	5	DSCP value for scheduled messages of the CIP transport class 0/1
	6	DSCP value for high-priority messages of the CIP transport class 0/1
	7	DSCP value for low-priority messages of the CIP transport class 0/1
	8	DSCP value for CIP explicit messages (transport class 2/3 and UCMM) and all other EtherNet/IP encapsulation messages

This instance supports the following services.

(a) When Ins ID is 0

Service Code	Name	Description
0Eh	Get_Attribute_Single	Reads the value of the specified attribute.

(b) When Ins ID is not 0

Service Code	Name	Description
0Eh	Get_Attribute_Single	Reads the value of the specified attribute.
10h	Set_Attribute_Single	Writes a value to the specified attribute.

19. EtherNet/IP COMMUNICATION

(5) TCP/IP Interface Object (Class ID: F5h)

Ins ID	Attr ID	Access	Name	Data Type
0	1	Get	Revision	UINT
	2		Max Instance	
	3		Number of Instance	
	6		Maximum ID Number Class Attributes	
	7		Maximum ID Number Instance Attributes	
1	1	Get/Set	Status	DWORD
	2		Configuration Capability	
	3	Configuration Control		
	4	Get	Port Object	Following structure UINT Padded EPATH
	5	Get/Set	Interface Configuration	Following structure UDINT
	6		Host Name	STRING
	8		TTL Value	USINT
	9		Mcast Config	Following structure
			Alloc Control	USINT
			Reserved	
		Num Mcast	UINT	
		Mcast Start Addr	UDINT	
10	Set	SelectAccd	Bool	
		Last ConflictDetected	Following structure	
11		AccdActivity	USINT	
		RemoteMAC	USINT array	
		ArpPdu		
12	EIP QuickConnect	Bool		

19. EtherNet/IP COMMUNICATION

Ins ID	Attr ID	Default	Range	Units	EEP-ROM	Parameter
0	1	0003h	0003h to 0003h		Impossible	
	2	1	0001h to 0001h			
	3	1	0001h to 0001h			
	6	7	0007h to 0007h			
	7	12	000Ch to 000Ch			
1	1		0000h to 00D8h			
	2		0000h to 00F4h			
	3		0000h to 0005h			
	4	0002h				
		20 F6 24 03h				
	5					
	6					
	8	1	01h to FFh			
	9	0				
	10		00h to FFh			
11						
12	0: Disabled 1: Enabled	00h to 01h				

19. EtherNet/IP COMMUNICATION

The network card provides a mechanism that sets a TCP/IP network interface (such as an IP address and network mask) of the device. The description of each Attribute is as follows.

Ins ID	Attr ID	Description	
0	1	Revision of this object	
	2	Maximum Instance number	
	3	Number of Instances	
	6	Last attribute ID of the class attribute	
	7	Last attribute ID of the instance attribute	
1	1	Interface status	
	2	Interface capability flag	
	3	Interface control flag	
	4		Size of Path
			Path to Instance #3 of Ethernet Link Object
	5		IP address
			Subnet mask
			Default gateway
			Primary DNS
			Secondary DNS
			Default domain
	6	Host name of the Anybus card	
	8	TTL value for EtherNet/IP multicast packets	
	9		IP multicast address configuration
			Multicast address allocation control word
			Number of IP multicast addresses to allocate for EtherNet/IP
			Starting multicast address from which to begin allocation
	10	Enable the use of ACD	
	11		Last collision information
			ACD status at the last collision
		MAC address of the remote node from an ARP PDU at collision detection	
		Copy of the ARP PDU at collision detection	
12	Enable or disable QuickConnect		

Status

bit	Name	Definition
0 to 3	Interface Configuration Status	Indicates the attribute status of Interface Configuration. 0: No Interface Configuration attribute has been set. 1: The Interface Configuration attribute includes an effective setting acquired from BOOTP, DHCP, or a non-volatile memory device. 2: The Interface Configuration attribute includes an effective setting acquired from a hardware setting. 3 to 15: Reserved
4	Mcast Pending	Undetermined setting changes in the TTL Value and Mcast Config attributes are returned. If the TTL Value or Mcast Config attribute has been set, this bit is cleared at the start of the next device.
5	Reserved	Reserved (Always 0)
6	AcdStatus	Indicates that the ACD has detected a duplication of an IP address. When the ACD has been supported and enabled, this bit turns to 1 at a detection of IP address duplication.
7	AcdFault	Indicates that the ACD has detected a collision of an IP address or has failed in protection. When this collision has disabled the current interface setting, this bit turns to 1.
8 to 31	Reserved	Reserved (Always 0)

19. EtherNet/IP COMMUNICATION

Configuration Capability

bit	Name	Definition
0	BOOTP Client (Note)	1 shall indicate the device is capable of obtaining its network configuration via BOOTP.
1	DNS Client (Note)	1 shall indicate the device is capable of resolving host names by querying a DNS server.
2	DHCP Client	1 shall indicate the device is capable of obtaining its network configuration via DHCP.
3	DHCP-DNS Update (Note)	1 shall indicate the device is capable of sending its host name in the DHCP request as documented in Internet draft (draft-ietf-dhcdhcp-dns-12.txt).
4	Configuration Settable	1 shall indicate the Interface Configuration attribute is settable.
5	Hardware Configurable	When this bit is 1, the IP address setting can be obtained from the hardware setting. (pushwheel switch, thumbwheel switch)
6	Interface Configuration Change Requires Reset	When this bit is 1, it indicates that resetting the device is required to apply the Interface Configuration attribute setting.
7	AcdCapable	When this bit is 1, it indicates that the device can use the ACD.
8 to 31	Reserved	Reserved (Always 0)

Note. This is not supported by the driver.

Configuration Control

bit	Name	Definition
0 to 3	Configuration Method	Determines how to obtain an IP address. 0: The device obtains an IP address from a value saved in the non-volatile memory. 1: The device obtains an interface setting via BOOTP. (Not supported) 2: The device obtains an interface setting via DHCP. 3 to 15: Reserved
4	DNS Enable	1 shall indicate the device is capable of resolving names by querying a DNS server. (Not supported)
5 to 31	Reserved	Reserved (Always 0)

This instance supports the following services.

(a) When Ins ID is 0

Service Code	Name	Description
01h	Get_Attributes_All	Reads the values of all the attributes.
0Eh	Get_Attribute_Single	Reads the value of the specified attribute.

(b) When Ins ID is not 0

Service Code	Name	Description
01h	Get_Attributes_All	Reads the values of all the attributes.
0Eh	Get_Attribute_Single	Reads the value of the specified attribute.
10h	Set_Attribute_Single	Writes a value to the specified attribute.

19. EtherNet/IP COMMUNICATION

(6) Ethernet Link Object (Class ID: F6h)

Ins ID	Attr ID	Access	Name	Data Type		
0	1		Revision	UINT		
	2		Max Instance			
	3		Number of Instance			
	6		Maximum ID Number Class Attributes			
	7		Maximum ID Number Instance Attributes			
1	1	Get	Interface Speed	UDINT		
	2		Interface Flags	DWORD		
	3		Physical Address	USINT array		
	4			Interface Counters	Following structure	
				In Octets	UDINT	
				In Ucast Packets		
				In NUCast Packets		
				In Discards		
				In Errors		
				In Unknown Protos		
				Out Octets		
				Out Ucast Packets		
				Out NUCast Packets		
				Out Discards		
				Out Errors		
				5		
	Alignment Errors		UDINT			
	FCS Errors					
	Single Collisions					
	Multiple Collisions					
	SQE Test Errors					
	Deferred Transmission					
	Late collisions					
	Excessive Collisions					
	MAC Transmit Errors					
	Carrier Sense Errors					
	Frame Too Long					
MAC Receive Errors						
6	Get/Set	Interface Control	Following structure			
		Control Bits	WORD			
		Forced Interface Speed	UINT			
7	Get	Interface Type	USINT			
		Interface State				
		Admin State				
		Interface Label		SHORT_STRING		

19. EtherNet/IP COMMUNICATION

Ins ID	Attr ID	Default	Range	Units	EEP-ROM	Parameter
0	1	0003h	0003h to 0003h		Impossible	
	2	3	0003h to 0003h			
	3	3	0003h to 0003h			
	6	7	0007h to 0007h			
	7	10	000Ah to 000Ah			
1	1		00000000h to 00000064h	Mbps		
	2		00000000h to 0000007Fh			
	3					
	4					
	5					
	6					
	7		01h to 02h			
	8		00h to 03h			
	9		00h to 02h			
	10					

19. EtherNet/IP COMMUNICATION

This object holds a link-specific counter and the status information of the IEEE802.3 communication interface. The description of each Attribute is as follows.

Ins ID	Attr ID	Description	
0	1	Revision of this object	
	2	Maximum Instance number	
	3	Number of Instances	
	6	Last attribute ID of the class attribute	
	7	Last attribute ID of the instance attribute	
1	1	Interface speed currently in use (10 Mbps or 100 Mbps)	
	2	Interface status flags (Refer to the following for details.)	
	3	MAC address	
	4		Octets received on the interface
			Unicast packets received on the interface
			Non-unicast packets received on the interface
			Inbound packets received on the interface but discarded
			Inbound packets that contain errors (does not include In Discards)
			Inbound packets with unknown protocol
			Octets sent on the interface
			Unicast packets sent on the interface
			Non-unicast packets sent on the interface
			Outbound packets discarded
			Outbound packets that contain errors
	5		Media-specific counters
			Frames received that are not an integral number of octets in length
			Frames received that do not pass the FCS check
			Successfully transmitted frames which experienced exactly one collision
			Successfully transmitted frames which experienced more than one collision
			Number of times SQE test error message is generated
			Frames for which first transmission attempt is delayed because the medium is busy
			Number of times a collision is detected later than 512 bit-times into the transmission of a packet
			Frames for which transmission fails due to an internal MAC sublayer transmission error
			Times that the carrier sense condition was lost or never asserted when attempting to transmit a frame
			Frames received that exceed the maximum permitted frame size
		Frames for which reception on an interface fails due to an internal MAC sublayer receive error	
	6		Configuration for physical interface
			Interface Control Bits
			Speed at which the interface shall be forced to operate
	7		Type of interface: twisted pair, fiber, internal, etc
	8		Current state of the interface: Operational, disabled, and etc
	9		Administrative state: enable, disable
10		Human readable identification	

19. EtherNet/IP COMMUNICATION

Interface Flags

bit	Name	Definition
0	Link Status	Indicates whether or not the IEEE802.3 communication interface is connected to an active network. 0 indicates an inactive link; 1 indicates an active link.
1	Half/Full Duplex	Indicates the duplex mode currently in use. 0 indicates the interface is running half duplex; 1 indicates full duplex. Note that if the Link Status flag is 0, this bit is indeterminate.
2 to 4	Negotiation Status	0: Auto-negotiation in progress. 1: Auto-negotiation and speed detection using default values for speed and duplex failed. 2: Auto negotiation failed but detected speed using default values for duplex. 3: Successfully negotiated speed and duplex. 4: Auto-negotiation not attempted. Use the values of Forced Duplex Mode and Forced Interface Speed.
5	Manual Setting Requires Speed	0 indicates the interface can activate changes to link parameters (auto negotiation, duplex mode, and interface speed) automatically. 1 indicates the device requires a Reset service be issued to its Identity Object in order for the changes to take effect.
6	Local Hardware Fault	0 indicates the interface detects no local hardware fault; 1 indicates a local hardware fault is detected.
7 to 31	Reserved	Reserved (Always 0)

This instance supports the following services.

(a) When Ins ID is 0

Service Code	Name	Description
01h	Get_Attributes_All	Reads the values of all the attributes.
0Eh	Get_Attribute_Single	Reads the value of the specified attribute.

(b) When Ins ID is not 0

Service Code	Name	Description
01h	Get_Attributes_All	Reads the values of all the attributes.
0Eh	Get_Attribute_Single	Reads the value of the specified attribute.
10h	Set_Attribute_Single	Writes a value to the specified attribute.
4Ch	Get_And_Clear	Only the Interface Counters and Media Counters attributes are supported. This service reads the value of the specified attribute and clears to 0. All the processing of this service is executed by the network card. For error information, refer to the specifications of the network card.

19. EtherNet/IP COMMUNICATION

19.7.3.3 Assembly Objects

(1) Assembly Object (Class ID: 04h)

Ins ID	Attr ID	Access	Name	Data Type
0	1	Get	Revision	UINT
	2	Get	Max Instance	
3	3	Set	Data	UINT
	4	Get	Size	
4	3	Set	Data	UINT
	4	Get	Size	
5	3	Set	Data	UINT
	4	Get	Size	
6	3	Set	Data	UINT
	4	Get	Size	
7	3	Set	Data	UINT
	4	Get	Size	
100 to 106	3	Set	Data	BYTE array
	4	Get	Size	UINT
150 to 156	3	Set	Data	BYTE array
	4	Get	Size	UINT

Ins ID	Attr ID	Default	Range	Units	EEP-ROM	Parameter
0	1	0002h	0002h to 0002h		Impossible	
	2		0000h to 009Ch			
3	3	No data				
	4	0	0000h to 0000h			
4	3	No data				
	4	0	0000h to 0000h			
5	3					
	4		0000h to FFFFh			
6	3	No data				
	4	0	0000h to 0000h			
7	3	No data				
	4	0	0000h to 0000h			
100 to 106	3	Refer to section 3.2.				
	4	Refer to section 3.2.	0000h to 0040h			
150 to 156	3	Refer to section 3.2.				
	4	Refer to section 3.2.	0000h to 0040h			

19. EtherNet/IP COMMUNICATION

This object defines a format of data transferred between the master and a slave through the I/O communication.

The driver periodically transfers commands and feedbacks using the format defined in Instance 100 to 102 and 150 to 152. For communication formats, refer to section 3.2. The description of each Attribute is as follows.

Ins ID	Attr ID	Description
0	1	Revision of this object
	2	Maximum Instance number
3	3	
	4	Number of bytes of attribute 3
4	3	
	4	Number of bytes of attribute 3
5	3	
	4	Number of bytes of attribute 3
6	3	
	4	Number of bytes of attribute 3
7	3	
	4	Number of bytes of attribute 3
100 to 106	3	
	4	Number of bytes of attribute 3
150 to 156	3	
	4	Number of bytes of attribute 3

This instance supports the following services.

(a) When Ins ID is 0

Service Code	Name	Description
0Eh	Get_Attribute_Single	Reads the value of the specified attribute.

(b) When Ins ID is not 0

Service Code	Name	Description
0Eh	Get_Attribute_Single	Reads the value of the specified attribute.
10h	Set_Attribute_Single	Writes a value to the specified attribute.

19. EtherNet/IP COMMUNICATION

19.7.3.4 Parameter Objects (Class ID: 64h)

The instances described in this section support the following service.

- When "Get" is in the "Access" field

Service Code	Name	Description
0Eh	Get_Attribute_Single	Reads the value of the specified attribute.

- When "Get/Set" is in the "Access" field

Service Code	Name	Description
0Eh	Get_Attribute_Single	Reads the value of the specified attribute.
10h	Set_Attribute_Single	Writes a value to the specified attribute.

(1) Parameter Objects PA (2001h to 2020h)

Ins ID	Attr ID	Access	Name	Data Type
2001h	0	Get/Set	PA01	DINT
.			.	
.			.	
2020h			PA32	

Ins ID	Attr ID	Default	Range	Units	EEP-ROM	Parameter
2001h	0				Possible	PA01
.		.				.
.		.				.
2020h						PA32

The values of the basic setting parameters ([Pr. PA_ _]) can be obtained and set.

(2) Parameter Objects PB (2081h to 20C0h)

Ins ID	Attr ID	Access	Name	Data Type
2081h	0	Get/Set	PB01	DINT
.			.	
.			.	
20C0h			PB64	

Ins ID	Attr ID	Default	Range	Units	EEP-ROM	Parameter
2081h	0				Possible	PB01
.		.				.
.		.				.
20C0h						PB64

The values of the gain/filter setting parameters ([Pr. PB_ _]) can be obtained and set.

19. EtherNet/IP COMMUNICATION

(3) Parameter Objects PC (2101h to 2150h)

Ins ID	Attr ID	Access	Name	Data Type
2101h	0	Get/Set	PC01	DINT
.			.	
.			.	
2150h			PC80	

Ins ID	Attr ID	Default	Range	Units	EEP-ROM	Parameter
2101h	0				Possible	PC01
.		.				
.		.				
2150h		PC80				

The values of the extension setting parameters ([Pr. PC_ _]) can be obtained and set.

(4) Parameter Objects PD (2181h to 21B0h)

Ins ID	Attr ID	Access	Name	Data Type
2181h	0	Get/Set	PD01	DINT
.			.	
.			.	
21B0h			PD48	

Ins ID	Attr ID	Default	Range	Units	EEP-ROM	Parameter
2181h	0				Possible	PD01
.		.				
.		.				
21B0h		PD48				

The values of the I/O setting parameters ([Pr. PD_ _]) can be obtained and set.

(5) Parameter Objects PE (2201h to 2240h)

Ins ID	Attr ID	Access	Name	Data Type
2201h	0	Get/Set	PE01	DINT
.			.	
.			.	
2240h			PE64	

Ins ID	Attr ID	Default	Range	Units	EEP-ROM	Parameter
2201h	0				Possible	PE01
.		.				
.		.				
2240h		PE64				

The values of the extension setting 2 parameters ([Pr. PE_ _]) can be obtained and set.

19. EtherNet/IP COMMUNICATION

(6) Parameter Objects PF (2281h to 22C0h)

Ins ID	Attr ID	Access	Name	Data Type
2281h	0	Get/Set	PF01	DINT
.			.	
.			.	
22C0h			PF64	

Ins ID	Attr ID	Default	Range	Units	EEP-ROM	Parameter
2281h	0				Possible	PF01
.		.				
.		.				
22C0h		PF64				

The values of the extension setting 3 parameters ([Pr. PF_ _]) can be obtained and set.

(7) Parameter Objects PL (2401h to 2430h)

Ins ID	Attr ID	Access	Name	Data Type
2401h	0	Get/Set	PL01	DINT
.			.	
.			.	
2430h			PL48	

Ins ID	Attr ID	Default	Range	Units	EEP-ROM	Parameter
2401h	0				Possible	PL01
.		.				
.		.				
2430h		PL48				

The values of the linear servo motor/DD motor setting parameters ([Pr. PL_ _]) can be obtained and set.

(8) Parameter Objects PT (2481h to 24D0h)

Ins ID	Attr ID	Access	Name	Data Type
2481h	0	Get/Set	PT01	DINT
.			.	
.			.	
24D0h			PT80	

Ins ID	Attr ID	Default	Range	Units	EEP-ROM	Parameter
2481h	0				Possible	PT01
.		.				
.		.				
24D0h		PT80				

The values of the positioning control parameters ([Pr. PT_ _]) can be obtained and set.

19. EtherNet/IP COMMUNICATION

(9) Parameter Objects PN (2581h to 25A0h)

Ins ID	Attr ID	Access	Name	Data Type
2581h	0	Get/Set	PN01	DINT
.			.	
.			.	
25A0h			PN32	

Ins ID	Attr ID	Default	Range	Units	EEP-ROM	Parameter
2581h	0				Possible	PN01
.		.				
.		.				
25A0h						PN32

The values of the network setting parameters ([Pr. PN_ _]) can be obtained and set.

19. 7. 3. 5 Alarm Objects (Class ID: 64h)

The instances described in this section support the following service.

- When "Get" is in the "Access" field

Service Code	Name	Description
0Eh	Get_Attribute_Single	Reads the value of the specified attribute.

- When "Set" is in the "Access" field

Service Code	Name	Description
10h	Set_Attribute_Single	Writes a value to the specified attribute.

19. EtherNet/IP COMMUNICATION

(1) Alarm history newest (2A00h)

Ins ID	Attr ID	Access	Name	Data Type
2A00h	0	Get	Alarm history newest	USINT
	1		Alarm No.	UDINT
	2		Alarm time (Hour)	

Ins ID	Attr ID	Default	Range	Units	EEP-ROM	Parameter
2A00h	0	2	02h to 02h		Possible	
	1	0	00000000h to FFFFFFFFh			
	2	0	00000000h to FFFFFFFFh	hour		

The latest alarm information of the alarm history is returned. The description of each Attribute ID is as follows.

Attr ID	Name	Description
0	Alarm history newest	The number of entries is returned.
1	Alarm No.	The number of the alarm that has occurred is returned. The description is as follows. When no history exists, 0 is returned. Bit 0 to Bit 15: Alarm detail No. Bit 16 to Bit 31: Alarm No. If [AL. 16.3] occurs, 00160003h is returned.
2	Alarm time (Hour)	Alarm occurrence time is returned. When no history exists, 0 is returned. Unit: [hour]

(2) Alarm history 1 (2A01h) to Alarm history 15 (2A0Fh)

Ins ID	Attr ID	Access	Name	Data Type
2A01h to 2A0Fh	0	Get	Alarm history 1 to Alarm history 15	USINT
	1		Alarm No.	UDINT
	2		Alarm time (Hour)	

Ins ID	Attr ID	Default	Range	Units	EEP-ROM	Parameter
2A01h to 2A0Fh	0	2	02h to 02h		Possible	
	1	0	00000000h to FFFFFFFFh			
	2	0	00000000h to FFFFFFFFh	hour		

The second (2A01h) to 16th (2A0Fh) latest alarm information of the alarm history is returned. The description of each Attribute ID is the same as that of (1) in this section.

(3) Clear alarm history (2A40h)

Ins ID	Attr ID	Access	Name	Data Type
2A40h	0	Set	Clear alarm history	UINT

Ins ID	Attr ID	Default	Range	Units	EEP-ROM	Parameter
2A40h	0		Refer to the text.		Impossible	

Writing "1EA5h" clears the alarm history.

19. EtherNet/IP COMMUNICATION

(4) Current alarm (2A41h)

Ins ID	Attr ID	Access	Name	Data Type
2A41h	0	Get	Current alarm	UDINT

Ins ID	Attr ID	Default	Range	Units	EEP-ROM	Parameter
2A41h	0		00000000h to FFFFFFFFh		Impossible	

The number of the current alarm is returned. When no alarm has occurred, "00000000h" is returned. The description of the values is as follows. If [AL. 16.3] occurs, "00160003h" is returned.

Bit	Description
0 to 15	Alarm detail No.
16 to 31	Alarm No.

(5) Parameter error number (2A44h)

Ins ID	Attr ID	Access	Name	Data Type
2A44h	0	Get	Parameter error number	UINT

Ins ID	Attr ID	Default	Range	Units	EEP-ROM	Parameter
2A44h	0		0000h to 01F4h (500)		Impossible	

When [AL. 37 Parameter error] has occurred, the number of the parameters which cause the error is returned. Refer to Parameter error list (Class ID: 64h, Ins ID: 2A45h) for the number of each parameter which causes the error.

19. EtherNet/IP COMMUNICATION

(6) Parameter error list (2A45h)

Ins ID	Attr ID	Access	Name	Data Type
2A45h	0	Get	Parameter error list	USINT
	1		No. 1	UINT
	.		.	
	.		.	
	16		No. 16	

Ins ID	Attr ID	Default	Range	Units	EEP-ROM	Parameter
2A45h	0		10h to 10h (16)		Impossible	
	1		0000h to FFFFh			
	.	.				
	.	.				
	16					

When [AL. 37 Parameter error] has occurred, the number of the parameter which causes the error is returned. The descriptions of 2A45h: 1 to 2A45h: 16 are as follows. If [Pr. PC01] is an error factor, 0201h is returned. If more than 17 parameter errors have occurred, the 17th and later parameter errors are returned after the parameters are corrected and the power is cycled.

Bit	Description
0 to 7	Parameter number
8 to 15	Parameter group number
	00: [Pr. PA __]
	01: [Pr. PB __]
	02: [Pr. PC __]
	03: [Pr. PD __]
	04: [Pr. PE __]
	05: [Pr. PF __]
	06: Parameter for manufacturer setting
	07: Parameter for manufacturer setting
	08: Parameter for manufacturer setting
	09: Parameter for manufacturer setting
	0A: Parameter for manufacturer setting
	0B: [Pr. PL __]
	0C: [Pr. PT __]
0E: [Pr. PN __]	

19. EtherNet/IP COMMUNICATION

19.7.3.6 Monitor Objects (Class ID: 64h)

The instances described in this section support the following service.

- When "Get" is in the "Access" field

Service Code	Name	Description
0Eh	Get_Attribute_Single	Reads the value of the specified attribute.

- When "Get/Set" is in the "Access" field

Service Code	Name	Description
0Eh	Get_Attribute_Single	Reads the value of the specified attribute.
10h	Set_Attribute_Single	Writes a value to the specified attribute.

(1) Cumulative feedback pulses (2B01h)

Ins ID	Attr ID	Access	Name	Data Type
2B01h	0	Get/Set	Cumulative feedback pulses	DINT

Ins ID	Attr ID	Default	Range	Units	EEP-ROM	Parameter
2B01h	0		80000000h to FFFFFFFFh	pulse	Impossible	

The cumulative feedback pulses are returned. Writing "00001EA5h" clears the cumulative feedback pulses.

(2) Servo motor speed (2B02h)

Ins ID	Attr ID	Access	Name	Data Type
2B02h	0	Get	Servo motor speed	DINT

Ins ID	Attr ID	Default	Range	Units	EEP-ROM	Parameter
2B02h	0		80000000h to 7FFFFFFFh	Refer to the text.	Impossible	

The servo motor speed is returned.

Unit: [r/min]

(3) Droop pulses (2B03h)

Ins ID	Attr ID	Access	Name	Data Type
2B03h	0	Get	Droop pulses	DINT

Ins ID	Attr ID	Default	Range	Units	EEP-ROM	Parameter
2B03h	0		80000000h to 7FFFFFFFh	pulse	Impossible	

The droop pulses (encoder unit) are returned.

19. EtherNet/IP COMMUNICATION

(4) Cumulative command pulses (2B04h)

Ins ID	Attr ID	Access	Name	Data Type
2B04h	0	Get	Cumulative command pulses	DINT

Ins ID	Attr ID	Default	Range	Units	EEP-ROM	Parameter
2B04h	0		80000000h to 7FFFFFFFh	pulse	Impossible	

The cumulative command pulses are returned.

(5) Command pulse frequency (2B05h)

Ins ID	Attr ID	Access	Name	Data Type
2B05h	0	Get	Command pulse frequency	DINT

Ins ID	Attr ID	Default	Range	Units	EEP-ROM	Parameter
2B05h	0		80000000h to 7FFFFFFFh	kpulse/s	Impossible	

The command pulse frequency is returned.

(6) Regenerative load ratio (2B08h)

Ins ID	Attr ID	Access	Name	Data Type
2B08h	0	Get	Regenerative load ratio	UINT

Ins ID	Attr ID	Default	Range	Units	EEP-ROM	Parameter
2B08h	0		0000h to FFFFh	%	Impossible	

The regenerative load ratio is returned.

(7) Effective load ratio (2B09h)

Ins ID	Attr ID	Access	Name	Data Type
2B09h	0	Get	Effective load ratio	UINT

Ins ID	Attr ID	Default	Range	Units	EEP-ROM	Parameter
2B09h	0		0000h to FFFFh	%	Impossible	

The effective load ratio is returned.

(8) Peak load ratio (2B0Ah)

Ins ID	Attr ID	Access	Name	Data Type
2B0Ah	0	Get	Peak load ratio	UINT

Ins ID	Attr ID	Default	Range	Units	EEP-ROM	Parameter
2B0Ah	0		0000h to FFFFh	%	Impossible	

The peak load ratio is returned.

19. EtherNet/IP COMMUNICATION

(9) Instantaneous torque (2B0Bh)

Ins ID	Attr ID	Access	Name	Data Type
2B0Bh	0	Get	Instantaneous torque	INT

Ins ID	Attr ID	Default	Range	Units	EEP-ROM	Parameter
2B0Bh	0		8000h to 7FFFh	%	Impossible	

The instantaneous torque is returned.

(10) Within one-revolution position (2B0Ch)

Ins ID	Attr ID	Access	Name	Data Type
2B0Ch	0	Get	Within one-revolution position	DINT

Ins ID	Attr ID	Default	Range	Units	EEP-ROM	Parameter
2B0Ch	0		80000000h to 7FFFFFFFh	pulse	Impossible	

The position within one-revolution is returned.

(11) ABS counter (2B0Dh)

Ins ID	Attr ID	Access	Name	Data Type
2B0Dh	0	Get	ABS counter	DINT

Ins ID	Attr ID	Default	Range	Units	EEP-ROM	Parameter
2B0Dh	0		80000000h to 7FFFFFFFh	rev	Impossible	

The ABS counter is returned.

(12) Load to motor inertia ratio (2B0Eh)

Ins ID	Attr ID	Access	Name	Data Type
2B0Eh	0	Get	Load to motor inertia ratio	UINT

Ins ID	Attr ID	Default	Range	Units	EEP-ROM	Parameter
2B0Eh	0		0000h to FFFFh	0.01 times	Impossible	

The load to motor inertia ratio is returned.

(13) Bus voltage (2B0Fh)

Ins ID	Attr ID	Access	Name	Data Type
2B0Fh	0	Get	Bus voltage	UINT

Ins ID	Attr ID	Default	Range	Units	EEP-ROM	Parameter
2B0Fh	0		0000h to FFFFh	V	Impossible	

The bus voltage is returned.

19. EtherNet/IP COMMUNICATION

(14) Load-side cumulative feedback pulses (2B10h)

Ins ID	Attr ID	Access	Name	Data Type
2B10h	0	Get	Load-side cumulative feedback pulses	DINT

Ins ID	Attr ID	Default	Range	Units	EEP-ROM	Parameter
2B10h	0		80000000h to 7FFFFFFFh	pulse	Impossible	

The load-side cumulative feedback pulses (load-side encoder unit) are returned.

(15) Load-side droop pulses (2B11h)

Ins ID	Attr ID	Access	Name	Data Type
2B11h	0	Get	Load-side droop pulses	DINT

Ins ID	Attr ID	Default	Range	Units	EEP-ROM	Parameter
2B11h	0		80000000h to 7FFFFFFFh	pulse	Impossible	

The load-side droop pulses are returned.

(16) Load-side encoder information 1 Z-phase counter (2B12h)

Ins ID	Attr ID	Access	Name	Data Type
2B12h	0	Get	Load-side encoder information 1 Z-phase counter	DINT

Ins ID	Attr ID	Default	Range	Units	EEP-ROM	Parameter
2B12h	0		80000000h to 7FFFFFFFh	pulse	Impossible	

The load-side encoder information 1 is returned.

(17) Load-side encoder information 2 (2B13h)

Ins ID	Attr ID	Access	Name	Data Type
2B13h	0	Get	Load-side encoder information 2	DINT

Ins ID	Attr ID	Default	Range	Units	EEP-ROM	Parameter
2B13h	0		80000000h to 7FFFFFFFh	rev	Impossible	

The load-side encoder information 2 is returned.

(18) Temperature of motor thermistor (2B17h)

Ins ID	Attr ID	Access	Name	Data Type
2B17h	0	Get	Temperature of motor thermistor	INT

Ins ID	Attr ID	Default	Range	Units	EEP-ROM	Parameter
2B17h	0		8000h to 7FFFh	°C	Impossible	

The temperature of servo motor thermistor is returned.

19. EtherNet/IP COMMUNICATION

(19) Motor-side cumu. feedback pulses (before gear) (2B18h)

Ins ID	Attr ID	Access	Name	Data Type
2B18h	0	Get	Motor-side cumu. feedback pulses (before gear)	DINT

Ins ID	Attr ID	Default	Range	Units	EEP-ROM	Parameter
2B18h	0		80000000h to 7FFFFFFFh	pulse	Impossible	

The cumulative feedback pulses are returned.

(20) Electrical angle (2B19h)

Ins ID	Attr ID	Access	Name	Data Type
2B19h	0	Get	Electrical angle	DINT

Ins ID	Attr ID	Default	Range	Units	EEP-ROM	Parameter
2B19h	0		80000000h to 7FFFFFFFh	pulse	Impossible	

The electrical angle is returned.

(21) Motor-side/load-side position deviation (2B23h)

Ins ID	Attr ID	Access	Name	Data Type
2B23h	0	Get	Motor-side/load-side position deviation	DINT

Ins ID	Attr ID	Default	Range	Units	EEP-ROM	Parameter
2B23h	0		80000000h to 7FFFFFFFh	pulse	Impossible	

The servo motor-side/load-side position deviation is returned.

(22) Motor-side/load-side speed deviation (2B24h)

Ins ID	Attr ID	Access	Name	Data Type
2B24h	0	Get	Motor-side/load-side speed deviation	DINT

Ins ID	Attr ID	Default	Range	Units	EEP-ROM	Parameter
2B24h	0		80000000h to 7FFFFFFFh	r/min	Impossible	

The servo motor-side/load-side speed deviation is returned.

(23) Internal temperature of encoder (2B25h)

Ins ID	Attr ID	Access	Name	Data Type
2B25h	0	Get	Internal temperature of encoder	INT

Ins ID	Attr ID	Default	Range	Units	EEP-ROM	Parameter
2B25h	0		8000h to 7FFFh	°C	Impossible	

The internal temperature of encoder is returned.

19. EtherNet/IP COMMUNICATION

(24) Settling time (2B26h)

Ins ID	Attr ID	Access	Name	Data Type
2B26h	0	Get	Settling time	INT

Ins ID	Attr ID	Default	Range	Units	EEP-ROM	Parameter
2B26h	0		8000h to 7FFFh	ms	Impossible	

The settling time is returned.

(25) Oscillation detection frequency (2B27h)

Ins ID	Attr ID	Access	Name	Data Type
2B27h	0	Get	Oscillation detection frequency	INT

Ins ID	Attr ID	Default	Range	Units	EEP-ROM	Parameter
2B27h	0		8000h to 7FFFh	Hz	Impossible	

The oscillation detection frequency is returned.

(26) Number of tough drive operations (2B28h)

Ins ID	Attr ID	Access	Name	Data Type
2B28h	0	Get	Number of tough drive operations	UINT

Ins ID	Attr ID	Default	Range	Units	EEP-ROM	Parameter
2B28h	0		0000h to FFFFh	number of times	Impossible	

The number of tough drive operations is returned.

(27) Unit power consumption (2B2Dh)

Ins ID	Attr ID	Access	Name	Data Type
2B2Dh	0	Get	Unit power consumption	INT

Ins ID	Attr ID	Default	Range	Units	EEP-ROM	Parameter
2B2Dh	0		8000h to 7FFFh	W	Impossible	

The unit power consumption is returned.

(28) Unit total power consumption (2B2Eh)

Ins ID	Attr ID	Access	Name	Data Type
2B2Eh	0	Get	Unit total power consumption	DINT

Ins ID	Attr ID	Default	Range	Units	EEP-ROM	Parameter
2B2Eh	0		80000000h to 7FFFFFFFh	Wh	Impossible	

The unit total power consumption is returned.

19. EtherNet/IP COMMUNICATION

(29) Alarm Monitor 1 Cumulative feedback pulses (2B81h)

Ins ID	Attr ID	Access	Name	Data Type
2B81h	0	Get	Alarm Monitor 1 Cumulative feedback pulses	DINT

Ins ID	Attr ID	Default	Range	Units	EEP-ROM	Parameter
2B81h	0		80000000h to 7FFFFFFFh	pulse	Impossible	

The cumulative feedback pulses at alarm occurrence are returned.

(30) Alarm Monitor 2 Servo motor speed (2B82h)

Ins ID	Attr ID	Access	Name	Data Type
2B82h	0	Get	Alarm Monitor 2 Servo motor speed	DINT

Ins ID	Attr ID	Default	Range	Units	EEP-ROM	Parameter
2B82h	0		80000000h to 7FFFFFFFh	Refer to the text.	Impossible	

The servo motor speed at alarm occurrence is returned.

Unit: [r/min]

(31) Alarm Monitor 3 Droop pulses (2B83h)

Ins ID	Attr ID	Access	Name	Data Type
2B83h	0	Get	Alarm Monitor 3 Droop pulses	DINT

Ins ID	Attr ID	Default	Range	Units	EEP-ROM	Parameter
2B83h	0		80000000h to 7FFFFFFFh	pulse	Impossible	

The droop pulses at alarm occurrence are returned.

(32) Alarm Monitor 4 Cumulative command pulses (2B84h)

Ins ID	Attr ID	Access	Name	Data Type
2B84h	0	Get	Alarm Monitor 4 Cumulative command pulses	DINT

Ins ID	Attr ID	Default	Range	Units	EEP-ROM	Parameter
2B84h	0		80000000h to 7FFFFFFFh	pulse	Impossible	

The cumulative command pulses (encoder unit) at alarm occurrence are returned.

(33) Alarm Monitor 5 Command pulse frequency (2B85h)

Ins ID	Attr ID	Access	Name	Data Type
2B85h	0	Get	Alarm Monitor 5 Command pulse frequency	DINT

Ins ID	Attr ID	Default	Range	Units	EEP-ROM	Parameter
2B85h	0		80000000h to 7FFFFFFFh	kpulse/s	Impossible	

The command pulse frequency at alarm occurrence is returned.

19. EtherNet/IP COMMUNICATION

(34) Alarm Monitor 8 Regenerative load ratio (2B88h)

Ins ID	Attr ID	Access	Name	Data Type
2B88h	0	Get	Alarm Monitor 8 Regenerative load ratio	UINT

Ins ID	Attr ID	Default	Range	Units	EEP-ROM	Parameter
2B88h	0		0000h to FFFFh	%	Impossible	

The regenerative load ratio at alarm occurrence is returned.

(35) Alarm Monitor 9 Effective load ratio (2B89h)

Ins ID	Attr ID	Access	Name	Data Type
2B89h	0	Get	Alarm Monitor 9 Effective load ratio	UINT

Ins ID	Attr ID	Default	Range	Units	EEP-ROM	Parameter
2B89h	0		0000h to FFFFh	%	Impossible	

The effective load ratio at alarm occurrence is returned.

(36) Alarm Monitor 10 Peak load ratio (2B8Ah)

Ins ID	Attr ID	Access	Name	Data Type
2B8Ah	0	Get	Alarm Monitor 10 Peak load ratio	UINT

Ins ID	Attr ID	Default	Range	Units	EEP-ROM	Parameter
2B8Ah	0		0000h to FFFFh	%	Impossible	

The peak load ratio at alarm occurrence is returned.

(37) Alarm Monitor 11 Instantaneous torque (2B8Bh)

Ins ID	Attr ID	Access	Name	Data Type
2B8Bh	0	Get	Alarm Monitor 11 Instantaneous torque	INT

Ins ID	Attr ID	Default	Range	Units	EEP-ROM	Parameter
2B8Bh	0		8000h to 7FFFh	%	Impossible	

The instantaneous torque at alarm occurrence is returned.

(38) Alarm Monitor 12 Within one-revolution position (2B8Ch)

Ins ID	Attr ID	Access	Name	Data Type
2B8Ch	0	Get	Alarm Monitor 12 Within one-revolution position	DINT

Ins ID	Attr ID	Default	Range	Units	EEP-ROM	Parameter
2B8Ch	0		80000000h to 7FFFFFFFh	pulse	Impossible	

The position within one-revolution at alarm occurrence is returned.

19. EtherNet/IP COMMUNICATION

(39) Alarm Monitor 13 ABS counter (2B8Dh)

Ins ID	Attr ID	Access	Name	Data Type
2B8Dh	0	Get	Alarm Monitor 13 ABS counter	DINT

Ins ID	Attr ID	Default	Range	Units	EEP-ROM	Parameter
2B8Dh	0		80000000h to 7FFFFFFFh	rev	Impossible	

The ABS counter at alarm occurrence is returned.

(40) Alarm Monitor 14 Load to motor inertia ratio (2B8Eh)

Ins ID	Attr ID	Access	Name	Data Type
2B8Eh	0	Get	Alarm Monitor 14 Load to motor inertia ratio	UINT

Ins ID	Attr ID	Default	Range	Units	EEP-ROM	Parameter
2B8Eh	0		0000h to FFFFh	0.1 times	Impossible	

The load to motor inertia ratio at alarm occurrence is returned.

(41) Alarm Monitor 15 Bus voltage (2B8Fh)

Ins ID	Attr ID	Access	Name	Data Type
2B8Fh	0	Get	Alarm Monitor 15 Bus voltage	DINT

Ins ID	Attr ID	Default	Range	Units	EEP-ROM	Parameter
2B8Fh	0		80000000h to 7FFFFFFFh	V	Impossible	

The bus voltage at alarm occurrence is returned.

(42) Alarm Monitor 16 Load-side cumulative feedback pulses (2B90h)

Ins ID	Attr ID	Access	Name	Data Type
2B90h	0	Get	Alarm Monitor 16 Load-side cumulative feedback pulses	DINT

Ins ID	Attr ID	Default	Range	Units	EEP-ROM	Parameter
2B90h	0		80000000h to 7FFFFFFFh	pulse	Impossible	

The load-side cumulative feedback pulses at alarm occurrence are returned.

(43) Alarm Monitor 17 Load-side droop pulses (2B91h)

Ins ID	Attr ID	Access	Name	Data Type
2B91h	0	Get	Alarm Monitor 17 Load-side droop pulses	DINT

Ins ID	Attr ID	Default	Range	Units	EEP-ROM	Parameter
2B91h	0		80000000h to 7FFFFFFFh	pulse	Impossible	

The load-side droop pulses (load-side encoder unit) at alarm occurrence are returned.

19. EtherNet/IP COMMUNICATION

(44) Alarm Monitor 18 Load-side encoder information 1 Z-phase counter (2B92h)

Ins ID	Attr ID	Access	Name	Data Type
2B92h	0	Get	Alarm Monitor 18 Load-side encoder information 1 Z-phase counter	DINT

Ins ID	Attr ID	Default	Range	Units	EEP-ROM	Parameter
2B92h	0		80000000h to 7FFFFFFFh	pulse	Impossible	

The load-side encoder information 1 at alarm occurrence is returned.

(45) Alarm Monitor 19 Load-side encoder information 2 (2B93h)

Ins ID	Attr ID	Access	Name	Data Type
2B93h	0	Get	Alarm Monitor 19 Load-side encoder information 2	DINT

Ins ID	Attr ID	Default	Range	Units	EEP-ROM	Parameter
2B93h	0		80000000h to 7FFFFFFFh	rev	Impossible	

The load-side encoder information 2 at alarm occurrence is returned.

(46) Alarm Monitor 23 Temperature of motor thermistor (2B97h)

Ins ID	Attr ID	Access	Name	Data Type
2B97h	0	Get	Alarm Monitor 23 Temperature of motor thermistor	DINT

Ins ID	Attr ID	Default	Range	Units	EEP-ROM	Parameter
2B97h	0		80000000h to 7FFFFFFFh	°C	Impossible	

The temperature of servo motor thermistor at alarm occurrence is returned.

(47) Alarm Monitor 24 Motor-side cumu. feedback pulses (before gear) (2B98h)

Ins ID	Attr ID	Access	Name	Data Type
2B98h	0	Get	Alarm Monitor 24 Motor-side cumu. feedback pulses (before gear)	DINT

Ins ID	Attr ID	Default	Range	Units	EEP-ROM	Parameter
2B98h	0		80000000h to 7FFFFFFFh	pulse	Impossible	

The cumulative feedback pulses (servo motor-side unit) at alarm occurrence are returned.

(48) Alarm Monitor 25 Electrical angle (2B99h)

Ins ID	Attr ID	Access	Name	Data Type
2B99h	0	Get	Alarm Monitor 25 Electrical angle	DINT

Ins ID	Attr ID	Default	Range	Units	EEP-ROM	Parameter
2B99h	0		80000000h to 7FFFFFFFh	pulse	Impossible	

The electrical angle at alarm occurrence is returned.

19. EtherNet/IP COMMUNICATION

(49) Alarm Monitor 35 Motor-side/load-side position deviation (2BA3h)

Ins ID	Attr ID	Access	Name	Data Type
2BA3h	0	Get	Alarm Monitor 35 Motor-side/load-side position deviation	DINT

Ins ID	Attr ID	Default	Range	Units	EEP-ROM	Parameter
2BA3h	0		80000000h to 7FFFFFFFh	pulse	Impossible	

The motor-side/load-side position deviation at alarm occurrence is returned.

(50) Alarm Monitor 36 Motor-side/load-side speed deviation (2BA4h)

Ins ID	Attr ID	Access	Name	Data Type
2BA4h	0	Get	Alarm Monitor 36 Motor-side/load-side speed deviation	DINT

Ins ID	Attr ID	Default	Range	Units	EEP-ROM	Parameter
2BA4h	0		80000000h to 7FFFFFFFh	r/min	Impossible	

The servo motor-side/load-side speed deviation at alarm occurrence is returned.

(51) Alarm Monitor 37 Internal temperature of encoder (2BA5h)

Ins ID	Attr ID	Access	Name	Data Type
2BA5h	0	Get	Alarm Monitor 37 Internal temperature of encoder	DINT

Ins ID	Attr ID	Default	Range	Units	EEP-ROM	Parameter
2BA5h	0		80000000h to 7FFFFFFFh	°C	Impossible	

The internal temperature of encoder at alarm occurrence is returned.

(52) Alarm Monitor 38 Settling time (2BA6h)

Ins ID	Attr ID	Access	Name	Data Type
2BA6h	0	Get	Alarm Monitor 38 Settling time	DINT

Ins ID	Attr ID	Default	Range	Units	EEP-ROM	Parameter
2BA6h	0		80000000h to 7FFFFFFFh	ms	Impossible	

The settling time at alarm occurrence is returned.

(53) Alarm Monitor 39 Oscillation detection frequency (2BA7h)

Ins ID	Attr ID	Access	Name	Data Type
2BA7h	0	Get	Alarm Monitor 39 Oscillation detection frequency	DINT

Ins ID	Attr ID	Default	Range	Units	EEP-ROM	Parameter
2BA7h	0		80000000h to 7FFFFFFFh	Hz	Impossible	

The oscillation detection frequency at alarm occurrence is returned.

19. EtherNet/IP COMMUNICATION

(54) Alarm Monitor 40 Number of tough drive operations (2BA8h)

Ins ID	Attr ID	Access	Name	Data Type
2BA8h	0	Get	Alarm Monitor 40 Number of tough drive operations	DINT

Ins ID	Attr ID	Default	Range	Units	EEP-ROM	Parameter
2BA8h	0		80000000h to 7FFFFFFFh	number of times	Impossible	

The number of tough drive operations at alarm occurrence is returned.

(55) Alarm Monitor 45 Unit power consumption (2BADh)

Ins ID	Attr ID	Access	Name	Data Type
2BADh	0	Get	Alarm Monitor 45 Unit power consumption	DINT

Ins ID	Attr ID	Default	Range	Units	EEP-ROM	Parameter
2BADh	0		80000000h to 7FFFFFFFh	W	Impossible	

The unit power consumption at alarm occurrence is returned.

(56) Alarm Monitor 46 Unit total power consumption (2BAEh)

Ins ID	Attr ID	Access	Name	Data Type
2BAEh	0	Get	Alarm Monitor 46 Unit total power consumption	DINT

Ins ID	Attr ID	Default	Range	Units	EEP-ROM	Parameter
2BAEh	0		80000000h to 7FFFFFFFh	Wh	Impossible	

The unit total power consumption at alarm occurrence is returned.

19. 7. 3. 7 Manufacturer Specific Control Objects (Class ID: 64h)

The instances described in this section support the following service.

- When "Get" is in the "Access" field

Service Code	Name	Description
0Eh	Get_Attribute_Single	Reads the value of the specified attribute.

- When "Set" is in the "Access" field

Service Code	Name	Description
10h	Set_Attribute_Single	Writes a value to the specified attribute.

- When "Get/Set" is in the "Access" field

Service Code	Name	Description
0Eh	Get_Attribute_Single	Reads the value of the specified attribute.
10h	Set_Attribute_Single	Writes a value to the specified attribute.

19. EtherNet/IP COMMUNICATION

(1) External Output pin display (2C11h)

Ins ID	Attr ID	Access	Name	Data Type
2C11h	0	Get	Number of entries	USINT
	1		External Output pin display1	UDINT

Ins ID	Attr ID	Default	Range	Units	EEP-ROM	Parameter
2C11h	0	2	02h to 02h		Impossible	
	1	0	00000000h to 0000000Fh			

The ON/OFF state of external output pins output from the driver can be read.
This object is available with drivers.

The following shows the detail of External Output pin display1. When the output of the target pin is on, "1" is returned. When the output of the target pin is off, "0" is returned. The values in the areas marked with diagonal lines at reading is undefined.

Bit	CN3 connector pin	Bit	CN3 connector pin	Bit	CN3 connector pin	Bit	CN3 connector pin
0	13	8		16		24	
1	15	9		17		25	
2	9	10		18		26	
3	8	11		19		27	
4		12		20		28	
5		13		21		29	
6		14		22		30	
7		15		23		31	

(2) Power ON cumulative time (2C18h)

Ins ID	Attr ID	Access	Name	Data Type
2C18h	0	Get	Power ON cumulative time	UDINT

Ins ID	Attr ID	Default	Range	Units	EEP-ROM	Parameter
2C18h	0		00000000h to FFFFFFFFh	hour	Impossible	

The cumulative energization time of the driver is returned.

(3) Number of inrush relay on/off times (2C19h)

Ins ID	Attr ID	Access	Name	Data Type
2C19h	0	Get	Number of inrush relay on/off times	UDINT

Ins ID	Attr ID	Default	Range	Units	EEP-ROM	Parameter
2C19h	0		00000000h to FFFFFFFFh	number of times	Impossible	

The number of on/off times of the inrush relay of the driver is returned.

19. EtherNet/IP COMMUNICATION

(4) Machine diagnostic status (2C20h)

Ins ID	Attr ID	Access	Name	Data Type
2C20h	0	Get	Machine diagnostic status	UINT

Ins ID	Attr ID	Default	Range	Units	EEP-ROM	Parameter
2C20h	0		Refer to the text.		Impossible	

The machine diagnostic status is returned. The description is as follows.

Bit	Description
0 to 3	Friction estimation status at forward rotation 0: Friction is being estimated. (normal) 1: Estimation is completed. (normal) 2: The servo motor may rotate in one direction too frequently. (warning) 3: The servo motor speed may too slow for friction estimation. (warning) 4: The change in the servo motor speed may be small for friction estimation. (warning) 5: The acceleration/deceleration time constants may be too short for friction estimation. (warning) 6: The operation time may not be enough. (warning) When warning conditions for 2 to 6 are met at the same time, the smaller number is returned. When an estimation is completed even though a warning has once occurred, the status changes to Estimation is completed.
4 to 7	Friction estimation status at reverse rotation 0: Friction is being estimated. (normal) 1: Estimation is completed. (normal) 2: The servo motor may rotate in one direction too frequently. (warning) 3: The servo motor speed may too slow for friction estimation. (warning) 4: The change in the servo motor speed may be small for friction estimation. (warning) 5: The acceleration/deceleration time constants may be too short for friction estimation. (warning) 6: The operation time may not be enough. (warning) When warning conditions for 2 to 6 are met at the same time, the smaller number is returned. When an estimation is completed even though a warning has once occurred, the status changes to Estimation is completed.
8 to 11	Vibration estimation status 0: During estimation 1: Estimation is completed.
12 to 15	(reserved) The value at reading is undefined.

(5) Static friction torque at forward rotation (2C21h)

Ins ID	Attr ID	Access	Name	Data Type
2C21h	0	Get	Static friction torque at forward rotation	INT

Ins ID	Attr ID	Default	Range	Units	EEP-ROM	Parameter
2C21h	0		8000h to 7FFFh	0.1%	Impossible	

Static friction torque at forward rotation is returned in increments of 0.1%.

19. EtherNet/IP COMMUNICATION

(6) Dynamic friction torque at forward rotation (at rated speed) (2C22h)

Ins ID	Attr ID	Access	Name	Data Type
2C22h	0	Get	Dynamic friction torque at forward rotation (at rated speed)	INT

Ins ID	Attr ID	Default	Range	Units	EEP-ROM	Parameter
2C22h	0		8000h to 7FFFh	0.1%	Impossible	

Dynamic friction torque at forward rotation at the rated speed is returned in increments of 0.1%.

(7) Static friction torque at reverse rotation (2C23h)

Ins ID	Attr ID	Access	Name	Data Type
2C23h	0	Get	Static friction torque at reverse rotation	INT

Ins ID	Attr ID	Default	Range	Units	EEP-ROM	Parameter
2C23h	0		8000h to 7FFFh	0.1%	Impossible	

Static friction torque at reverse rotation is returned in increments of 0.1%.

(8) Dynamic friction torque at reverse rotation (at rated speed) (2C24h)

Ins ID	Attr ID	Access	Name	Data Type
2C24h	0	Get	Dynamic friction torque at reverse rotation (at rated speed)	INT

Ins ID	Attr ID	Default	Range	Units	EEP-ROM	Parameter
2C24h	0		8000h to 7FFFh	0.1%	Impossible	

Dynamic friction torque at reverse rotation at rated speed is returned in increments of 0.1%.

(9) Oscillation frequency during motor stop (2C25h)

Ins ID	Attr ID	Access	Name	Data Type
2C25h	0	Get	Oscillation frequency during motor stop	INT

Ins ID	Attr ID	Default	Range	Units	EEP-ROM	Parameter
2C25h	0		8000h to 7FFFh	Hz	Impossible	

Vibration frequency during stop/servo-lock is returned in increments of 1 Hz.

(10) Vibration level during motor stop (2C26h)

Ins ID	Attr ID	Access	Name	Data Type
2C26h	0	Get	Vibration level during motor stop	INT

Ins ID	Attr ID	Default	Range	Units	EEP-ROM	Parameter
2C26h	0		8000h to 7FFFh	0.1%	Impossible	

Vibration level during stop/servo-lock is returned in increments of 0.1%.

19. EtherNet/IP COMMUNICATION

(11) Oscillation frequency during motor operating (2C27h)

Ins ID	Attr ID	Access	Name	Data Type
2C27h	0	Get	Oscillation frequency during motor operating	INT

Ins ID	Attr ID	Default	Range	Units	EEP-ROM	Parameter
2C27h	0		8000h to 7FFFh	Hz	Impossible	

Vibration frequency during operation is returned in increments of 1 Hz.

(12) Vibration level during motor operating (2C28h)

Ins ID	Attr ID	Access	Name	Data Type
2C28h	0	Get	Vibration level during motor operating	INT

Ins ID	Attr ID	Default	Range	Units	EEP-ROM	Parameter
2C28h	0		8000h to 7FFFh	0.1%	Impossible	

Vibration level during operation is returned in increments of 0.1%.

(13) Control DI 1 (2D01h)

Ins ID	Attr ID	Access	Name	Data Type
2D01h	0	Get/Set	Control DI 1	UINT

Ins ID	Attr ID	Default	Range	Units	EEP-ROM	Parameter
2D01h	0	0	Refer to the text.		Impossible	

Set control commands to control the driver. Refer to section 5.2.2 (1) for details.

(14) Control DI 2 (2D02h)

Ins ID	Attr ID	Access	Name	Data Type
2D02h	0	Get/Set	Control DI 2	UINT

Ins ID	Attr ID	Default	Range	Units	EEP-ROM	Parameter
2D02h	0	0	Refer to the text.		Impossible	

Set control commands to control the driver. Refer to section 5.2.2 (2) for details.

(15) Control DI 3 (2D03h)

Ins ID	Attr ID	Access	Name	Data Type
2D03h	0	Get/Set	Control DI 3	UINT

Ins ID	Attr ID	Default	Range	Units	EEP-ROM	Parameter
2D03h	0	0	Refer to the text.		Impossible	

Set control commands to control the driver. Refer to section 5.2.2 (3) for details.

19. EtherNet/IP COMMUNICATION

(16) Control DI 7 (2D07h)

Ins ID	Attr ID	Access	Name	Data Type
2D07h	0	Get/Set	Control DI 7	UINT

Ins ID	Attr ID	Default	Range	Units	EEP-ROM	Parameter
2D07h	0	0	Refer to the text.		Impossible	

Set control commands to control the driver. Refer to section 5.2.2 (4) for details.

(17) Control DI 10 (2D0Ah)

Ins ID	Attr ID	Access	Name	Data Type
2D0Ah	0	Get/Set	Control DI 10	UINT

Ins ID	Attr ID	Default	Range	Units	EEP-ROM	Parameter
2D0Ah	0	0	Refer to the text.		Impossible	

Set control commands to control the driver. Refer to section 5.2.2 (5) for details.

(18) Status DO 1 (2D11h)

Ins ID	Attr ID	Access	Name	Data Type
2D11h	0	Get	Status DO 1	UINT

Ins ID	Attr ID	Default	Range	Units	EEP-ROM	Parameter
2D11h	0		Refer to the text.		Impossible	

The servo status is returned. Refer to section 5.3.2 (1) for details.

(19) Status DO 2 (2D12h)

Ins ID	Attr ID	Access	Name	Data Type
2D12h	0	Get	Status DO 2	UINT

Ins ID	Attr ID	Default	Range	Units	EEP-ROM	Parameter
2D12h	0		Refer to the text.		Impossible	

The servo status is returned. Refer to section 5.3.2 (2) for details.

(20) Status DO 3 (2D13h)

Ins ID	Attr ID	Access	Name	Data Type
2D13h	0	Get	Status DO 3	UINT

Ins ID	Attr ID	Default	Range	Units	EEP-ROM	Parameter
2D13h	0		Refer to the text.		Impossible	

The servo status is returned. Refer to section 5.3.2 (3) for details.

19. EtherNet/IP COMMUNICATION

(21) Status DO 5 (2D15h)

Ins ID	Attr ID	Access	Name	Data Type
2D15h	0	Get	Status DO 5	UINT

Ins ID	Attr ID	Default	Range	Units	EEP-ROM	Parameter
2D15h	0		Refer to the text.		Impossible	

The servo status is returned. Refer to section 5.3.2 (4) for details.

(22) Status DO 6 (2D16h)

Ins ID	Attr ID	Access	Name	Data Type
2D16h	0	Get	Status DO 6	UINT

Ins ID	Attr ID	Default	Range	Units	EEP-ROM	Parameter
2D16h	0		Refer to the text.		Impossible	

The servo status is returned. Refer to section 5.3.2 (5) for details.

(23) Status DO 7 (2D17h)

Ins ID	Attr ID	Access	Name	Data Type
2D17h	0	Get	Status DO 7	UINT

Ins ID	Attr ID	Default	Range	Units	EEP-ROM	Parameter
2D17h	0		Refer to the text.		Impossible	

The servo status is returned. Refer to section 5.3.2 (6) for details.

(24) Status DO 10 (2D1Ah)

Ins ID	Attr ID	Access	Name	Data Type
2D1Ah	0	Get	Status DO 10	UINT

Ins ID	Attr ID	Default	Range	Units	EEP-ROM	Parameter
2D1Ah	0		Refer to the text.		Impossible	

The servo status is returned. Refer to section 5.3.2 (7) for details.

(25) Velocity limit value (2D20h)

Ins ID	Attr ID	Access	Name	Data Type
2D20h	0	Get/Set	Velocity limit value	UDINT

Ins ID	Attr ID	Default	Range	Units	EEP-ROM	Parameter
2D20h	0	50000	00000000h to instantaneous permissible speed	vel units	Possible	PT67

Set the speed limit value for the profile torque mode (tq).

Unit: [0.01 r/min]

19. EtherNet/IP COMMUNICATION

(26) Motor rated speed (2D28h)

Ins ID	Attr ID	Access	Name	Data Type
2D28h	0	Get	Motor rated speed	UDINT

Ins ID	Attr ID	Default	Range	Units	EEP-ROM	Parameter
2D28h	0		00000000h to FFFFFFFFh	r/min	Impossible	

The servo motor rated speed is returned.

Unit: [r/min]

(27) Manufacturer Device Name 2 (2D30h)

Ins ID	Attr ID	Access	Name	Data Type
2D30h	0 to _	Get	Manufacturer Device Name 2	STRING

Ins ID	Attr ID	Default	Range	Units	EEP-ROM	Parameter
2D30h	0 to _				Impossible	

The model name of the driver is returned.

The number of character strings is set to Attribute ID 0 and ASCII code is registered to Attribute ID 1 or later.

(28) Manufacturer Hardware Version 2 (2D31h)

Ins ID	Attr ID	Access	Name	Data Type
2D31h	0 to _	Get	Manufacturer Hardware Version 2	STRING

Ins ID	Attr ID	Default	Range	Units	EEP-ROM	Parameter
2D31h	0 to _				Impossible	

The hardware version of the driver is returned.

The number of character strings is set to Attribute ID 0 and ASCII code is registered to Attribute ID 1 or later.

(29) Manufacturer Software Version 2 (2D32h)

Ins ID	Attr ID	Access	Name	Data Type
2D32h	0 to _	Get	Manufacturer Software Version 2	STRING

Ins ID	Attr ID	Default	Range	Units	EEP-ROM	Parameter
2D32h	0 to _				Impossible	

The software version of the driver is returned.

The number of character strings is set to Attribute ID 0 and ASCII code is registered to Attribute ID 1 or later.

19. EtherNet/IP COMMUNICATION

(30) Serial Number 2 (2D33h)

Ins ID	Attr ID	Access	Name	Data Type
2D33h	0 to _	Get	Serial Number 2	STRING

Ins ID	Attr ID	Default	Range	Units	EEP-ROM	Parameter
2D33h	0 to _				Impossible	

The serial number of the driver is returned.

The number of character strings is set to Attribute ID 0 and ASCII code is registered to Attribute ID 1 or later.

(31) User parameter configuration (2D34h)

Ins ID	Attr ID	Access	Name	Data Type
2D34h	0	Get/Set	User parameter configuration	UINT

Ins ID	Attr ID	Default	Range	Units	EEP-ROM	Parameter
2D34h	0	1	Refer to the text.		Impossible	

The parameters whose symbols are preceded by * are not automatically enabled. Writing "1EA5h" to this object enables the parameters. This operation can be performed only when I/O connection is not in the Run mode.

The read values of this object are as follows. The completion of the parameter enables processing can be checked.

Value	Description
0	Parameter enabling processing is being executed.
1	Parameter enabling processing is not being executed. (The processing is completed.)

19. EtherNet/IP COMMUNICATION

(32) Encoder status (2D35h)

Ins ID	Attr ID	Access	Name	Data Type
2D35h	0	Get	Encoder status	USINT
	1		Encoder status1	UDINT
	2		Encoder status2	

Ins ID	Attr ID	Default	Range	Units	EEP-ROM	Parameter
2D35h	0	2	02h to 02h		Impossible	
	1		00000000h to 00000001h			
	2		00000000h to 00000007h			

The status of the encoder is returned. The description of each Attribute ID is as follows.

Attr ID	Name	Description
0	Encoder status	Number of entries
1	Encoder status1	The status of the encoder is returned. For a fully closed loop system, the external encoder status is returned. Bit 0: Whether the driver is used in an absolute position detection system or not is returned. 0 = Incremental system 1 = Absolute position detection system Bit 1 to Bit 31: Reserved
2	Encoder status2	The status of the scale measurement encoder is returned. Bit 0: Whether the driver is used in an absolute position detection system or not is returned. 0 = Incremental system 1 = Absolute position detection system Bit 1: Whether the scale measurement function is enabled or disabled is returned. 0 = Disabled 1 = Enabled Bit 2: Whether the connected scale measurement encoder is the absolute position type or not is returned. 0 = Incremental type 1 = Absolute position type Bit 3 to Bit 31: Reserved

(33) Scale cycle counter (2D36h)

Ins ID	Attr ID	Access	Name	Data Type
2D36h	0	Get	Scale cycle counter	UDINT

Ins ID	Attr ID	Default	Range	Units	EEP-ROM	Parameter
2D36h	0		00000000h to FFFFFFFFh	pulse	Impossible	

The position within one-revolution of the scale measurement encoder is returned. Returned values differ depending on the scale measurement encoder type.

Scale measurement encoder	Description
Rotary encoder	Cycle counter
Linear encoder Absolute position type	ABS counter
Linear encoder Incremental type	Scale coasting counter
Linear encoder A/B/Z-phase differential output type Incremental type	Scale coasting counter

19. EtherNet/IP COMMUNICATION

(34) Scale ABS counter (2D37h)

Ins ID	Attr ID	Access	Name	Data Type
2D37h	0	Get	Scale ABS counter	DINT

Ins ID	Attr ID	Default	Range	Units	EEP-ROM	Parameter
2D37h	0		80000000h to 7FFFFFFFh	rev	Impossible	

The ABS counter of the scale measurement encoder is returned. Returned values differ depending on the scale measurement encoder type.

Scale measurement encoder	Description
Rotary encoder	Multi-revolution ABS counter
Linear encoder Absolute position type	Fixed to 0
Linear encoder Incremental type	Fixed to 0
Linear encoder A/B/Z-phase differential output type Incremental type	Fixed to 0

(35) Scale measurement encoder resolution (2D38h)

Ins ID	Attr ID	Access	Name	Data Type
2D38h	0	Get	Scale measurement encoder resolution	UDINT

Ins ID	Attr ID	Default	Range	Units	EEP-ROM	Parameter
2D38h	0		00000000h to FFFFFFFFh	inc / rev	Impossible	

The resolution of the scale measurement encoder is returned.

(36) Scale measurement encoder reception status (2D3Ch)

Ins ID	Attr ID	Access	Name	Data Type
2D3Ch	0	Get	Scale measurement encoder reception status (Note)	UDINT

Ins ID	Attr ID	Default	Range	Units	EEP-ROM	Parameter
2D3Ch	0		00000000h to FFFFFFFFh		Impossible	

The alarm data of the scale measurement encoder is returned. The value "0" indicates that no error occurs. A value other than "0" indicates that an error occurs.

19. EtherNet/IP COMMUNICATION

(37) One-touch tuning mode (2D50h)

Ins ID	Attr ID	Access	Name	Data Type
2D50h	0	Get/Set	One-touch tuning mode	USINT

Ins ID	Attr ID	Default	Range	Units	EEP-ROM	Parameter
2D50h	0		00h to 03h		Impossible	

Setting a value of "1" to "3" starts one-touch tuning. After one-touch tuning is completed, the setting value automatically changes to "0". The description of the setting values is as follows.

Setting value	Description
0	During one-touch tuning stop
1	Basic mode
2	High mode
3	Low mode

(38) One-touch tuning status (2D51h)

Ins ID	Attr ID	Access	Name	Data Type
2D51h	0	Get	One-touch tuning status	SINT

Ins ID	Attr ID	Default	Range	Units	EEP-ROM	Parameter
2D51h	0		00h to 64h	%	Impossible	

The one-touch tuning progress is returned.

(39) One-touch tuning Stop (2D52h)

Ins ID	Attr ID	Access	Name	Data Type
2D52h	0	Set	One-touch tuning Stop	UINT

Ins ID	Attr ID	Default	Range	Units	EEP-ROM	Parameter
2D52h	0		0000h/1EA5h		Impossible	

Writing "1EA5h" can stop one-touch tuning. Writing a value other than "1EA5h" sets a general-purpose code 09h Invalid attribute value.

(40) One-touch tuning Clear (2D53h)

Ins ID	Attr ID	Access	Name	Data Type
2D53h	0	Set	One-touch tuning Clear	UINT

Ins ID	Attr ID	Default	Range	Units	EEP-ROM	Parameter
2D53h	0		0000h to 0001h		Impossible	

The parameter changed in one-touch tuning can be returned to the value before the change. The description of the setting values is as follows.

Setting value	Description
0000h	Restores the initial value.
0001h	Restores the value before one-touch tuning.

19. EtherNet/IP COMMUNICATION

(41) One-touch tuning Error Code (2D54h)

Ins ID	Attr ID	Access	Name	Data Type
2D54h	0	Get	One-touch tuning Error Code	UINT

Ins ID	Attr ID	Default	Range	Units	EEP-ROM	Parameter
2D54h	0		0000h to C00Fh		Impossible	

An error code of the one-touch tuning is returned. The description of the error codes is as follows.

Error code	Description
0000h	Finished normally
C000h	Tuning canceled
C001h	Overshoot exceeded
C002h	Servo-off during tuning
C003h	Control mode error
C004h	Time-out
C005h	Load to motor inertia ratio misestimated
C00Fh	One-touch tuning disabled

19. 7. 3. 8 PDS Control Objects (Class ID: 64h)

The instances described in this section support the following service.

- When "Get" is in the "Access" field

Service Code	Name	Description
0Eh	Get_Attribute_Single	Reads the value of the specified attribute.

- When "Set" is in the "Access" field

Service Code	Name	Description
10h	Set_Attribute_Single	Writes a value to the specified attribute.

- When "Get/Set" is in the "Access" field

Service Code	Name	Description
0Eh	Get_Attribute_Single	Reads the value of the specified attribute.
10h	Set_Attribute_Single	Writes a value to the specified attribute.

(1) Error code (603Fh)

Ins ID	Attr ID	Access	Name	Data Type
603Fh	0	Get	Error code	UINT

Ins ID	Attr ID	Default	Range	Units	EEP-ROM	Parameter
603Fh	0	0	0000h to FFFFh		Impossible	

The number of the latest error that occurred after the power on is returned.

19. EtherNet/IP COMMUNICATION

(2) Controlword (6040h)

Ins ID	Attr ID	Access	Name	Data Type
6040h	0	Get/Set	Controlword	UINT

Ins ID	Attr ID	Default	Range	Units	EEP-ROM	Parameter
6040h	0	0	Refer to the text.		Impossible	

Set control commands to control the driver. Refer to section 5.2.1 for details.

(3) Statusword (6041h)

Ins ID	Attr ID	Access	Name	Data Type
6041h	0	Get	Statusword	UINT

Ins ID	Attr ID	Default	Range	Units	EEP-ROM	Parameter
6041h	0		Refer to the text.		Impossible	

The servo status is returned. Refer to section 5.3.1 for details.

(4) Quick stop option code (605Ah)

Ins ID	Attr ID	Access	Name	Data Type
605Ah	0	Get/Set	Quick stop option code	INT

Ins ID	Attr ID	Default	Range	Units	EEP-ROM	Parameter
605Ah	0	2	0002h to 0002h		Possible	PT68

Set how to decelerate the servo motor to a stop at QuickStop reception. The description of the setting values is as follows.

Setting value	Description
1	
2	In the profile mode (pp/pv) and homing mode (hm), the servo motor decelerates to a stop with Quick stop deceleration (Class ID: 64h, Ins ID: 6085h, Attr ID: 0) and the state shifts to the Switch On Disabled state. In the profile torque mode (tq), the state immediately shifts to the Switch On Disabled state and the servo motor stops with the dynamic brake.
3	
4	
5	
6	
7	
8	

19. EtherNet/IP COMMUNICATION

(5) Halt option code (605Dh)

Ins ID	Attr ID	Access	Name	Data Type
605Dh	0	Get/Set	Halt option code	INT

Ins ID	Attr ID	Default	Range	Units	EEP-ROM	Parameter
605Dh	0	1	0001h to 0001h		Possible	PT68

Set how to decelerate the servo motor to a stop at Halt reception. The description of the setting values is as follows.

Setting value	Description
1	For Profile deceleration (Class ID: 64h, Ins ID: 6084h, Attr ID: 0) and the homing mode (hm), the servo motor decelerates to a stop according to Homing acceleration (Class ID: 64h, Ins ID: 6094h, Attr ID: 0) and the state does not change from the Operation Enabled state (servo-on).
2	
3	
4	

(6) Modes of operation (6060h)

Ins ID	Attr ID	Access	Name	Data Type
6060h	0	Get/Set	Modes of operation	SINT

Ins ID	Attr ID	Default	Range	Units	EEP-ROM	Parameter
6060h	0	0	Refer to the text.		Impossible	

Set the control mode. The setting values are as follows.

Setting value	Description
0	No mode change/No mode assigned
1	Profile position mode (pp)
3	Profile velocity mode (pv)
4	Profile torque mode (tq)
6	Homing mode (hm)

The settable values are limited depending on the setting of [Pr. PA01]. Refer to section 5.4.1 for details.

19. EtherNet/IP COMMUNICATION

(7) Modes of operation display (6061h)

Ins ID	Attr ID	Access	Name	Data Type
6061h	0	Get	Modes of operation display	SINT

Ins ID	Attr ID	Default	Range	Units	EEP-ROM	Parameter
6061h	0	1	Refer to the text.		Impossible	

The current control mode is returned. The description is as follows.

Setting value	Description
0	No mode assigned
1	Profile position mode (pp)
3	Profile velocity mode (pv)
4	Profile torque mode (tq)
6	Homing mode (hm)

(8) Supported drive modes (6502h)

Ins ID	Attr ID	Access	Name	Data Type
6502h	0	Get	Supported drive modes	UDINT

Ins ID	Attr ID	Default	Range	Units	EEP-ROM	Parameter
6502h	0	Refer to the text.	Refer to the text.		Impossible	

The supported control mode is returned. The description is as follows.

Bit	Description	Defined value
0	Profile position mode (pp)	1: Supported
1	Velocity mode (vl)	0
2	Profile velocity mode (pv)	1: Supported
3	Profile torque mode (tq)	1: Supported
4	Reserved	0
5	Homing mode (hm)	1: Supported
6	Interpolated position mode (ip)	0
7	Cyclic synchronous position mode (csp)	0
8	Cyclic synchronous velocity mode (csv)	0
9	Cyclic synchronous torque mode (cst)	0
10	Cyclic synchronous torque mode with communication angle (cstca)	0
11 to 31	Reserved	0

A fixed value is returned regardless of the [Pr. PA01] setting.

19. EtherNet/IP COMMUNICATION

19.7.3.9 Position Control Function Objects (Class ID: 64h)

The instances described in this section support the following service.

- When "Get" is in the "Access" field

Service Code	Name	Description
0Eh	Get_Attribute_Single	Reads the value of the specified attribute.

- When "Set" is in the "Access" field

Service Code	Name	Description
10h	Set_Attribute_Single	Writes a value to the specified attribute.

- When "Get/Set" is in the "Access" field

Service Code	Name	Description
0Eh	Get_Attribute_Single	Reads the value of the specified attribute.
10h	Set_Attribute_Single	Writes a value to the specified attribute.

(1) Position actual internal value (6063h)

Ins ID	Attr ID	Access	Name	Data Type
6063h	0	Get	Position actual internal value	DINT

Ins ID	Attr ID	Default	Range	Units	EEP-ROM	Parameter
6063h	0		80000000h to 7FFFFFFFh	inc	Impossible	

The current position is returned.

(2) Position actual value (6064h)

Ins ID	Attr ID	Access	Name	Data Type
6064h	0	Get	Position actual value	DINT

Ins ID	Attr ID	Default	Range	Units	EEP-ROM	Parameter
6064h	0		80000000h to 7FFFFFFFh	pos units	Impossible	

The current position in the command unit is returned.

(3) Following error window (6065h)

Ins ID	Attr ID	Access	Name	Data Type
6065h	0	Get/Set	Following error window	UDINT

Ins ID	Attr ID	Default	Range	Units	EEP-ROM	Parameter
6065h	0	00C00000h	00000000h to FFFFFFFFh	pos units	Possible	PC67/PC68

In the profile position mode (pp), when the time set with Following error time out (Class ID: 64h, Ins ID: 6066h, Attr ID: 0) has elapsed with the number of droop pulses exceeding the setting value of this object, Bit 13 of Statusword (Class ID: 64h, Ins ID: 6041h, Attr ID: 0) is turned on. When "FFFFFFFh" is set, Bit 13 of Statusword (Class ID: 64h, Ins ID: 6041h, Attr ID: 0) is always off.

19. EtherNet/IP COMMUNICATION

(4) Following error time out (6066h)

Ins ID	Attr ID	Access	Name	Data Type
6066h	0	Get/Set	Following error time out	UINT

Ins ID	Attr ID	Default	Range	Units	EEP-ROM	Parameter
6066h	0	10	0000h to FFFFh	ms	Possible	PC69

Refer to Following error window (Class ID: 64h, Ins ID: 6065h, Attr ID: 0).

(5) Position window (6067h)

Ins ID	Attr ID	Access	Name	Data Type
6067h	0	Get/Set	Position window	UDINT

Ins ID	Attr ID	Default	Range	Units	EEP-ROM	Parameter
6067h	0	100	Refer to the text.	pos units	Possible	PC70

The description of this object is as follows.

Setting value	Description
00000000h to 0000FFFEh	In the profile position mode (pp), when the time set with Position windows time (Class ID: 64h, Ins ID: 6068h, Attr ID: 0) has elapsed with the number of droop pulses equal to or lower than the setting value of this object, Bit 10 of Statusword (Class ID: 64h, Ins ID: 6041h, Attr ID: 0) is turned on.
0000FFFFh to FFFFFFFEh	Unsettable
FFFFFFFFh	Bit 10 of Statusword (Class ID: 64h, Ins ID: 6041h, Attr ID: 0) is always on in the profile position mode (pp).

(6) Position window time (6068h)

Ins ID	Attr ID	Access	Name	Data Type
6068h	0	Get/Set	Position window time	UINT

Ins ID	Attr ID	Default	Range	Units	EEP-ROM	Parameter
6068h	0	10	0000h to FFFFh	ms	Possible	PC71

Refer to Position window (Class ID: 64h, Ins ID: 6067h, Attr ID: 0).

19. EtherNet/IP COMMUNICATION

(7) Positioning option code (60F2h)

Ins ID	Attr ID	Access	Name	Data Type
60F2h	0	Get/Set	Positioning option code	UINT

Ins ID	Attr ID	Default	Range	Units	EEP-ROM	Parameter
60F2h	0	0000h	0000h to 00C0h		Possible	PT03

Set the profile position mode. The description of this object is as follows.

Bit	Description	Defined value
0 to 1	00b: The positioning is performed with the relative position from the internal absolute target position. 01b: The positioning is performed with the relative position from Position demand actual value (Class ID: 64h, Ins ID: 60FCh, Attr ID: 0). (Not supported) (Note) 10b: The positioning is performed with the relative position from Position actual value (Class ID: 64h, Ins ID: 6064h, Attr ID: 0). (Not supported) (Note) 11b: reserved	00b
2 to 3	00b: New values of Target position (Class ID: 64h, Ins ID: 607Ah, Attr ID: 0), Profile velocity (Class ID: 64h, Ins ID: 6081h, Attr ID: 0), and Acceleration are promptly applied. 01b: The current positioning continues to reach the target position. Then new values of Target position (Class ID: 64h, Ins ID: 607Ah, Attr ID: 0), Profile velocity (Class ID: 64h, Ins ID: 6081h, Attr ID: 0), and Acceleration are applied. (Not supported) (Note) 10b: reserved 11b: reserved	00b
4 to 5	Reserved	0
6 to 7	00b: The servo motor rotates to the target position in a direction specified with a sign of the position data. 01b: The servo motor rotates in the address decreasing direction regardless of the sign of the position data. 10b: The servo motor rotates in the address increasing direction regardless of the sign of the position data. 11b: The servo motor rotates from the current position to the target position in the shorter direction. If the distances from the current position to the target position are the same for CCW and CW, the servo motor rotates in the CCW direction.	00b
8 to 15	Reserved	0

Note. This is not supported by the driver.

(8) Following error actual value (60F4h)

Ins ID	Attr ID	Access	Name	Data Type
60F4h	0	Get	Following error actual value	DINT

Ins ID	Attr ID	Default	Range	Units	EEP-ROM	Parameter
60F4h	0		80000000h to 7FFFFFFFh	pos units	Impossible	

The droop pulses are returned.

19. EtherNet/IP COMMUNICATION

(9) Control effort (60FAh)

Ins ID	Attr ID	Access	Name	Data Type
60FAh	0	Get	Control effort	DINT

Ins ID	Attr ID	Default	Range	Units	EEP-ROM	Parameter
60FAh	0		80000000h to 7FFFFFFFh	vel units	Impossible	

The speed command is returned.

Unit: [0.01 r/min]

19. 7. 3. 10 Profile Velocity Mode Objects (Class ID: 64h)

The instances described in this section support the following service.

- When "Get" is in the "Access" field

Service Code	Name	Description
0Eh	Get_Attribute_Single	Reads the value of the specified attribute.

- When "Set" is in the "Access" field

Service Code	Name	Description
10h	Set_Attribute_Single	Writes a value to the specified attribute.

- When "Get/Set" is in the "Access" field

Service Code	Name	Description
0Eh	Get_Attribute_Single	Reads the value of the specified attribute.
10h	Set_Attribute_Single	Writes a value to the specified attribute.

(1) Velocity demand value (606Bh)

Ins ID	Attr ID	Access	Name	Data Type
606Bh	0	Get	Velocity demand value	DINT

Ins ID	Attr ID	Default	Range	Units	EEP-ROM	Parameter
606Bh	0		80000000h to 7FFFFFFFh	vel units	Impossible	

The speed command is returned.

Unit: [0.01 r/min]

(2) Velocity actual value (606Ch)

Ins ID	Attr ID	Access	Name	Data Type
606Ch	0	Get	Velocity actual value	DINT

Ins ID	Attr ID	Default	Range	Units	EEP-ROM	Parameter
606Ch	0		80000000h to 7FFFFFFFh	vel units	Impossible	

The current speed is returned.

Unit: [0.01 r/min]

19. EtherNet/IP COMMUNICATION

(3) Velocity window (606Dh)

Ins ID	Attr ID	Access	Name	Data Type
606Dh	0	Get/Set	Velocity window	UINT

Ins ID	Attr ID	Default	Range	Units	EEP-ROM	Parameter
606Dh	0	2000	0000h to FFFFh	vel units	Possible	PC72

In the profile velocity mode (pv), when the time set with Velocity window time (Class ID: 64h, Ins ID: 606Eh, Attr ID: 0) has elapsed with the current speed equal to or lower than the setting value of this object, Bit 10 of Statusword (Class ID: 64h, Ins ID: 6041h, Attr ID: 0) is turned on.

Unit: [0.01 r/min]

(4) Velocity window time (606Eh)

Ins ID	Attr ID	Access	Name	Data Type
606Eh	0	Get/Set	Velocity window time	UINT

Ins ID	Attr ID	Default	Range	Units	EEP-ROM	Parameter
606Eh	0	10	0000h to FFFFh	ms	Possible	PC73

Refer to Velocity window (Class ID: 64h, Ins ID: 606Dh, Attr ID: 0).

(5) Velocity threshold (606Fh)

Ins ID	Attr ID	Access	Name	Data Type
606Fh	0	Get/Set	Velocity threshold	UINT

Ins ID	Attr ID	Default	Range	Units	EEP-ROM	Parameter
606Fh	0	5000	0000h to FFFFh	vel units	Possible	PC65

In the profile velocity mode (pv), when the time set with Velocity threshold time (Class ID: 64h, Ins ID: 6070h, Attr ID: 0) has elapsed with the current speed higher than the setting value of this object, Bit 12 of Statusword (Class ID: 64h, Ins ID: 6041h, Attr ID: 0) is turned off.

Unit: [0.01 r/min]

(6) Velocity threshold time (6070h)

Ins ID	Attr ID	Access	Name	Data Type
6070h	0	Get/Set	Velocity threshold time	UINT

Ins ID	Attr ID	Default	Range	Units	EEP-ROM	Parameter
6070h	0	10	0000h to FFFFh	ms	Possible	PC66

Refer to Velocity threshold (Class ID: 64h, Ins ID: 606Fh, Attr ID: 0).

(7) Target velocity (60FFh)

Ins ID	Attr ID	Access	Name	Data Type
60FFh	0	Get/Set	Target velocity	DINT

Ins ID	Attr ID	Default	Range	Units	EEP-ROM	Parameter
60FFh	0	0	80000000h to 7FFFFFFFh	vel units	Impossible	

Set the speed command used in the profile velocity mode (pv).

Unit: [0.01 r/min]

19. EtherNet/IP COMMUNICATION

19.7.3.11 Profile Torque Mode Objects (Class ID: 64h)

The instances described in this section support the following service.

- When "Get" is in the "Access" field

Service Code	Name	Description
0Eh	Get_Attribute_Single	Reads the value of the specified attribute.

- When "Set" is in the "Access" field

Service Code	Name	Description
10h	Set_Attribute_Single	Writes a value to the specified attribute.

- When "Get/Set" is in the "Access" field

Service Code	Name	Description
0Eh	Get_Attribute_Single	Reads the value of the specified attribute.
10h	Set_Attribute_Single	Writes a value to the specified attribute.

(1) Target torque (6071h)

Ins ID	Attr ID	Access	Name	Data Type
6071h	0	Get/Set	Target torque	INT

Ins ID	Attr ID	Default	Range	Units	EEP-ROM	Parameter
6071h	0	0	8000h to 7FFFh	per thousand of rated torque	Impossible	

Set the torque command used in the profile torque mode (tq).

(2) Max torque (6072h)

Ins ID	Attr ID	Access	Name	Data Type
6072h	0	Get/Set	Max torque	UINT

Ins ID	Attr ID	Default	Range	Units	EEP-ROM	Parameter
6072h	0		0000h to FFFFh	per thousand of rated torque	Impossible	

The maximum torque of the servo motor is returned. The values notified by this object are the maximum current and feedback value.

(3) Torque demand value (6074h)

Ins ID	Attr ID	Access	Name	Data Type
6074h	0	Get	Torque demand value	INT

Ins ID	Attr ID	Default	Range	Units	EEP-ROM	Parameter
6074h	0		8000h to 7FFFh	per thousand of rated torque	Impossible	

The torque command is returned.

19. EtherNet/IP COMMUNICATION

(4) Torque actual value (6077h)

Ins ID	Attr ID	Access	Name	Data Type
6077h	0	Get	Torque actual value	INT

Ins ID	Attr ID	Default	Range	Units	EEP-ROM	Parameter
6077h	0		8000h to 7FFFh	per thousand of rated torque	Impossible	

The current torque is returned.

(5) Torque slope (6087h)

Ins ID	Attr ID	Access	Name	Data Type
6087h	0	Get/Set	Torque slope	UDINT

Ins ID	Attr ID	Default	Range	Units	EEP-ROM	Parameter
6087h	0	00000000h	00000000h to 00989680h (10000000)	per thousand of rated torque per second	Possible	PT53

Set the variation per second of the torque command used in the profile torque mode. When "0" is set, the setting value is invalid and the torque command is input with step input.

(6) Torque profile type (6088h)

Ins ID	Attr ID	Access	Name	Data Type
6088h	0	Get/Set	Torque profile type	INT

Ins ID	Attr ID	Default	Range	Units	EEP-ROM	Parameter
6088h	0	0	0000h to 0000h		Impossible	

Set the torque command pattern. The description is as follows.

Setting value	Description
0	Linear ramp
1	sin ² ramp (Not supported) (Note)

Note. This is not supported by the driver.

Values other than "0" cannot be set.

(7) Positive torque limit value (60E0h)

Ins ID	Attr ID	Access	Name	Data Type
60E0h	0	Get/Set	Positive torque limit value	UINT

Ins ID	Attr ID	Default	Range	Units	EEP-ROM	Parameter
60E0h	0	10000	0000h to 2710h (10000)	per thousand of rated torque	Possible	PA11 (POL disabled), PA12 (POL enabled)

You can limit the torque generated by the servo motor. Set the limit value of the torque of the servo motor in the CCW power running or CW regeneration. Set this object to "0" to generate no torque

19. EtherNet/IP COMMUNICATION

(8) Negative torque limit value (60E1h)

Ins ID	Attr ID	Access	Name	Data Type
60E1h	0	Get/Set	Negative torque limit value	UINT

Ins ID	Attr ID	Default	Range	Units	EEP-ROM	Parameter
60E1h	0	10000	0000h to 2710h (10000)	per thousand of rated torque	Possible	PA12 (POL disabled), PA11 (POL enabled)

You can limit the torque generated by the servo motor. Set the limit value of the torque of the servo motor in the CW power running or CCW regeneration. Set this object to "0" to generate no torque

19. 7. 3. 12 Profile Position Mode Objects (Class ID: 64h)

The instances described in this section support the following service.

- When "Get" is in the "Access" field

Service Code	Name	Description
0Eh	Get_Attribute_Single	Reads the value of the specified attribute.

- When "Set" is in the "Access" field

Service Code	Name	Description
10h	Set_Attribute_Single	Writes a value to the specified attribute.

- When "Get/Set" is in the "Access" field

Service Code	Name	Description
0Eh	Get_Attribute_Single	Reads the value of the specified attribute.
10h	Set_Attribute_Single	Writes a value to the specified attribute.

(1) Target position (607Ah)

Ins ID	Attr ID	Access	Name	Data Type
607Ah	0	Get/Set	Target position	DINT

Ins ID	Attr ID	Default	Range	Units	EEP-ROM	Parameter
607Ah	0	0	Refer to the text.	pos units	Impossible	

Set the position command used in the profile position mode (pp). The settable values vary depending on the setting of [Pr. PT01]. When using superimposed synchronous control, set compensation amounts for the servo motor rotation position. A positive superimposed feed length adds compensation to superimposed control in the command address increasing direction, and a negative superimposed feed length adds compensation in the command address decreasing direction.

[Pr. PT01] setting	Range
_ 0 _ _ (mm)	FFF0BDC1h to 000F423Fh (-999999 to 999999)
_ 1 _ _ (inch)	FFF0BDC1h to 000F423Fh (-999999 to 999999)
_ 2 _ _ (degree)	FFFA81C0h to 00057E40h (-360000 to 360000)
_ 3 _ _ (pulse)	FFF0BDC1h to 000F423Fh (-999999 to 999999)

Set also Gear ratio (Class ID: 64h, Ins ID: 6091h, Attr ID: 0) for the profile position mode (pp).

19. EtherNet/IP COMMUNICATION

(2) Position range limit (607Bh)

Ins ID	Attr ID	Access	Name	Data Type
607Bh	0	Get	Position range limit	USINT
	1	Get/Set	Min position range limit	DINT
	2		Max position range limit	

Ins ID	Attr ID	Default	Range	Units	EEP-ROM	Parameter
607Bh	0	2	00h to 02h		Impossible	
	1		Refer to the text.	pos units		
	2					

No value can be written because Position range limit (Class ID: 64h, Ins ID: 607Ah) is set automatically with the control mode and [Pr. PT01]. Writing a value sets a general-purpose code 09h Invalid attribute value.

[Pr. PT01] setting	Range
_ 0 _ (mm)	80000000h to 7FFFFFFFh (-2147483648 to 2147483647)
_ 1 _ (inch)	80000000h to 7FFFFFFFh (-2147483648 to 2147483647)
_ 2 _ (degree)	00000000h to 00057E3Fh (0 to 359999)
_ 3 _ (pulse)	80000000h to 7FFFFFFFh (-2147483648 to 2147483647)

(3) Software position limit (607Dh)

Ins ID	Attr ID	Access	Name	Data Type
607Dh	0	Get	Software position limit	USINT
	1	Get/Set	Min position limit	DINT
	2		Max position limit	

Ins ID	Attr ID	Default	Range	Units	EEP-ROM	Parameter
607Dh	0	2	02h to 02h		Impossible	
	1	0	80000000h to 7FFFFFFFh	pos units		
	2					

Set the range for limiting the command position. Target position (Class ID: 64h, Ins ID: 607Ah, Attr ID: 0) is limited within the range between Min position limit (Class ID: 64h, Ins ID: 607Dh, Attr ID: 1) and Max position limit (Class ID: 64h, Ins ID: 607Dh, Attr ID: 2). When the set value of Min position limit (Class ID: 64h, Ins ID: 607Dh, Attr ID: 1) is equal to or greater than the set value of Max position limit (Class ID: 64h, Ins ID: 607Dh, Attr ID: 2), the function of Software position limit (Class ID: 64h, Ins ID: 607Dh, Attr ID: 0) is disabled.

(4) Max profile velocity (607Fh)

Ins ID	Attr ID	Access	Name	Data Type
607Fh	0	Get/Set	Max profile velocity	UDINT

Ins ID	Attr ID	Default	Range	Units	EEP-ROM	Parameter
607Fh	0	2000000	00000000h to 001E8480h (2000000)	vel units	Possible	PT66

Set the speed limit value for the profile position mode (pp) and profile velocity mode (pv). When a value exceeding this object is set to Target velocity (Class ID: 64h, Ins ID: 60FFh, Attr ID: 0) or Profile velocity (Class ID: 64h, Ins ID: 6081h, Attr ID: 0), the speed is limited with the value of this object.

19. EtherNet/IP COMMUNICATION

(5) Max motor speed (6080h)

Ins ID	Attr ID	Access	Name	Data Type
6080h	0	Get/Set	Max motor speed	UDINT

Ins ID	Attr ID	Default	Range	Units	EEP-ROM	Parameter
6080h	0		00000000h to FFFFFFFFh	Refer to the text.	Impossible	

The instantaneous permissible speed of the servo motor is returned. Operation cannot be performed at a speed exceeding the speed set with this object.

Unit: [r/min]

(6) Profile velocity (6081h)

Ins ID	Attr ID	Access	Name	Data Type
6081h	0	Get/Set	Profile velocity	UDINT

Ins ID	Attr ID	Default	Range	Units	EEP-ROM	Parameter
6081h	0	10000	00000000h to instantaneous permissible speed	vel units	Possible	PT65

Set the command speed in the profile position mode (pp). Set a value within the range between "0" and permissible speed. When using superimposed synchronous control, set a superimposed feed speed at a start of the superimposed control. Set a value within the range between "0" and permissible speed.

Unit: [0.01 r/min]

(7) Profile acceleration (6083h)

Ins ID	Attr ID	Access	Name	Data Type
6083h	0	Get/Set	Profile acceleration	UDINT

Ins ID	Attr ID	Default	Range	Units	EEP-ROM	Parameter
6083h	0	0	Refer to the text.	ms	Possible	PT49

Set the acceleration time constant in the profile position mode (pp) and the profile velocity mode (pv). Set a time for the servo motor to reach the rated speed. The settable values vary depending on the control mode. When using superimposed synchronous control, set an acceleration time constant for the superimposed control. Set a time for the servo motor to reach the rated speed.

Control mode	Range
Profile position mode (pp)	0 to 20000
Profile velocity mode (pv)	0 to 50000

19. EtherNet/IP COMMUNICATION

(8) Profile deceleration (6084h)

Ins ID	Attr ID	Access	Name	Data Type
6084h	0	Get/Set	Profile deceleration	UDINT

Ins ID	Attr ID	Default	Range	Units	EEP-ROM	Parameter
6084h	0	0	Refer to the text.	ms	Possible	PT50

Set the deceleration time constant in the profile position mode (pp) and the profile velocity mode (pv). Set a time for the servo motor to stop from the rated speed. The settable values vary depending on the control mode. When using superimposed synchronous control, set a deceleration time constant for the superimposed control. Set a time for the servo motor to stop from the rated speed.

Control mode	Range
Profile position mode (pp)	0 to 20000
Profile velocity mode (pv)	0 to 50000

(9) Quick stop deceleration (6085h)

Ins ID	Attr ID	Access	Name	Data Type
6085h	0	Get/Set	Quick stop deceleration	UDINT

Ins ID	Attr ID	Default	Range	Units	EEP-ROM	Parameter
6085h	0	100	0 to 20000	ms	Possible	PC24

Set a deceleration time constant for the Quick stop function. Set a time for the servo motor to stop from the rated speed. When "0" is set, the operation is performed with 100 ms.

(10) Motion profile type (6086h)

Ins ID	Attr ID	Access	Name	Data Type
6086h	0	Get/Set	Motion profile type	INT

Ins ID	Attr ID	Default	Range	Units	EEP-ROM	Parameter
6086h	0	-1	FFFFh to FFFFh (-1)		Impossible	

Set the acceleration/deceleration pattern in the profile position mode (pp). The description is as follows.

Setting value	Description
-1	S-pattern
0	Linear ramp (Not supported) (Note)
1	sin ² ramp (Not supported) (Note)
2	Jerk-free ramp (Not supported) (Note)
3	Jerk-limited ramp (Not supported) (Note)

Note. This is not supported by the driver.

For this object, "-1" is always returned. Values other than "-1" cannot be set.

19. EtherNet/IP COMMUNICATION

(11) External encoder gear ratio (2DF0h)

Ins ID	Attr ID	Access	Name	Data Type
2DF0h	0	Get	External encoder gear ratio	USINT
	1	Get/Set	External encoder gear numerator	DINT
	2		External encoder gear denominator	

Ins ID	Attr ID	Default	Range	Units	EEP-ROM	Parameter
2DF0h	0	2	02h to 02h		Impossible	
	1	1	00000001h to 7FFFFFFFh (2147483647)	rev	Possible	PT72/PT73
	2					PT74/PT75

Set a synchronous encoder electronic gear for converting a synchronous encoder command into a command unit. A value written to this object is not immediately applied to the synchronous encoder electronic gear. To apply the value of this object to the synchronous encoder electronic gear, turn on Analysis command (C_CEG).

(12) External encoder acceleration (2DF1h)

Ins ID	Attr ID	Access	Name	Data Type
2DF1h	0	Get/Set	External encoder acceleration	UDINT

Ins ID	Attr ID	Default	Range	Units	EEP-ROM	Parameter
2DF1h	0	0	00000000h to 00004E20h (20000)	ms	Impossible	

Set a time for the servo motor to reach the rated speed for a synchronous encoder command when Synchronous control command (C_STS) is turned on. A setting value when Synchronous control command (C_STS) is turned on will be applied.

(13) External encoder deceleration (2DF2h)

Ins ID	Attr ID	Access	Name	Data Type
2DF2h	0	Get/Set	External encoder deceleration	UDINT

Ins ID	Attr ID	Default	Range	Units	EEP-ROM	Parameter
2DF2h	0	0	00000000h to 00004E20h (20000)	ms	Impossible	

Set a time for the servo motor to stop from the rated speed for a synchronous encoder command when Synchronous control command (C_STS) is turned off. A setting value when Synchronous control command (C_STS) is turned on will be applied.

19. EtherNet/IP COMMUNICATION

19.7.3.13 Homing Mode Objects (Class ID: 64h)

The instances described in this section support the following service.

- When "Get" is in the "Access" field

Service Code	Name	Description
0Eh	Get_Attribute_Single	Reads the value of the specified attribute.

- When "Set" is in the "Access" field

Service Code	Name	Description
10h	Set_Attribute_Single	Writes a value to the specified attribute.

- When "Get/Set" is in the "Access" field

Service Code	Name	Description
0Eh	Get_Attribute_Single	Reads the value of the specified attribute.
10h	Set_Attribute_Single	Writes a value to the specified attribute.

(1) Home offset (607Ch)

Ins ID	Attr ID	Access	Name	Data Type
607Ch	0	Get/Set	Home offset	DINT

Ins ID	Attr ID	Default	Range	Units	EEP-ROM	Parameter
607Ch	0	0	80000000h to 7FFFFFFFh	pos units	Possible	

The home position is returned. Only reading the value is available. Do not perform writing because doing so causes an error.

(2) Homing method (6098h)

Ins ID	Attr ID	Access	Name	Data Type
6098h	0	Get/Set	Homing method	SINT

Ins ID	Attr ID	Default	Range	Units	EEP-ROM	Parameter
6098h	0	37	D5h (-43) to 25h (37)		Possible	PT45

Set a home position return type. Refer to section 5.4.6 (4) for the settable values.

19. EtherNet/IP COMMUNICATION

(3) Homing speeds (6099h)

Ins ID	Attr ID	Access	Name	Data Type
6099h	0	Get	Homing speeds	USINT
	1	Get/Set	Speed during search for switch	UDINT
	2		Speed during search for zero	

Ins ID	Attr ID	Default	Range	Units	EEP-ROM	Parameter
6099h	0	2	02h to 02h		Impossible	
	1	10000	0 to instantaneous permissible speed	vel units	Possible	PT05
	2	1000				PT06

Set the servo motor speed at home position return.

Set the servo motor speed at home position return for Speed during search for switch (Class ID: 64h, Ins ID: 6099h, Attr ID: 1).

Unit: [0.01 r/min]

Set the creep speed after proximity dog at home position return for Speed during search for zero (Class ID: 64h, Ins ID: 6099h, Attr ID: 2).

Unit: [0.01 r/min]

(4) Homing acceleration (609Ah)

Ins ID	Attr ID	Access	Name	Data Type
609Ah	0	Get/Set	Homing acceleration	UDINT

Ins ID	Attr ID	Default	Range	Units	EEP-ROM	Parameter
609Ah	0	0	00000000h to 00004E20h (20000)	ms	Possible	PT56

Set the acceleration/deceleration time constants at home position return. Set a time for the servo motor to reach the rated speed.

19. EtherNet/IP COMMUNICATION

(5) Supported homing method (60E3h)

Ins ID	Attr ID	Access	Name	Data Type
60E3h	0	Get	Supported homing method	USINT
	1		1st supported homing method	SINT
	2		2nd supported homing method	
	3		3rd supported homing method	
	4		4th supported homing method	
	5		5th supported homing method	
	6		6th supported homing method	
	7		7th supported homing method	
	8		8th supported homing method	
	9		9th supported homing method	
	10		10th supported homing method	
	11		11th supported homing method	
	12		12th supported homing method	
	13		13th supported homing method	
	14		14th supported homing method	
	15		15th supported homing method	
	16		16th supported homing method	
	17		17th supported homing method	
	18		18th supported homing method	
	19		19th supported homing method	
	20		20th supported homing method	
	21		21st supported homing method	
	22		22nd supported homing method	
	23		23rd supported homing method	
	24		24th supported homing method	
	25		25th supported homing method	
	26		26th supported homing method	
	27		27th supported homing method	
	28		28th supported homing method	
	29		29th supported homing method	
	30		30th supported homing method	
	31		31st supported homing method	
	32		32nd supported homing method	
	33		33rd supported homing method	
	34		34th supported homing method	
	35		35th supported homing method	
	36		36th supported homing method	
	37		37th supported homing method	
	38		38th supported homing method	
	39		39th supported homing method	

19. EtherNet/IP COMMUNICATION

Ins ID	Attr ID	Default	Range	Units	EEP-ROM	Parameter
60E3h	0	39	27h (39)		Impossible	
	1	37	25h (37)			
	2	35	23h (35)			
	3	34	22h (34)			
	4	33	21h (33)			
	5	28	1Ch (28)			
	6	27	1Bh (27)			
	7	24	18h (24)			
	8	23	17h (23)			
	9	22	16h (22)			
	10	21	15h (21)			
	11	20	14h (20)			
	12	19	13h (19)			
	13	12	0Ch (12)			
	14	11	0Bh (11)			
	15	8	08h (8)			
	16	7	07h (7)			
	17	6	06h (6)			
	18	5	05h (5)			
	19	4	04h (4)			
	20	3	03h (3)			
	21	-1	FFh (-1)			
	22	-2	FEh (-2)			
	23	-3	FDh (-3)			
	24	-4	FCh (-4)			
	25	-6	FAh (-6)			
	26	-7	F9h (-7)			
	27	-8	F8h (-8)			
	28	-9	F7h (-9)			
	29	-10	F6h (-10)			
	30	-11	F5h (-11)			
	31	-33	DFh (-33)			
	32	-34	DEh (-34)			
	33	-36	DCh (-36)			
	34	-38	DAh (-38)			
	35	-39	D9h (-39)			
	36	-40	D8h (-40)			
	37	-41	D7h (-41)			
	38	-42	D6h (-42)			
39	-43	D5h (-43)				

The supported home position return type is returned.

19. EtherNet/IP COMMUNICATION

19.7.3.14 Factor Group Objects

The instances described in this section support the following service.

- When "Get" is in the "Access" field

Service Code	Name	Description
0Eh	Get_Attribute_Single	Reads the value of the specified attribute.

- When "Get/Set" is in the "Access" field

Service Code	Name	Description
0Eh	Get_Attribute_Single	Reads the value of the specified attribute.
10h	Set_Attribute_Single	Writes a value to the specified attribute.

(1) Polarity (607Eh)

Ins ID	Attr ID	Access	Name	Data Type
607Eh	0	Get/Set	Polarity	USINT

Ins ID	Attr ID	Default	Range	Units	EEP-ROM	Parameter
607Eh	0	00h	Refer to the text.		Possible	PA14 PC29

The rotation direction selection can be set.

Bit	Description
0	reserved
1	reserved
2	reserved
3	reserved
4	reserved
5	0: Servo motor CCW rotation at positive torque 1: Servo motor CW rotation at positive torque
6	0: Servo motor CCW rotation at positive speed 1: Servo motor CW rotation at positive speed
7	0: Servo motor CCW rotation in positioning address increasing direction 1: Servo motor CW rotation in positioning address increasing direction

Only "00h", "C0h", and "E0h" can be set. Values other than 00h, C0h, and E0h cannot be set.

(2) Position encoder resolution (608Fh)

Ins ID	Attr ID	Access	Name	Data Type
608Fh	0	Get	Position encoder resolution	USINT
	1	Get/Set	Encoder increments	UDINT
	2		Motor revolutions	

Ins ID	Attr ID	Default	Range	Units	EEP-ROM	Parameter
608Fh	0	2	02h to 02h	inc / rev	Impossible	
	1		00000000h to FFFFFFFFh	inc		
	2	1	00000001h to 00000001h	rev		

Encoder resolution is returned with Encoder increments (Class ID: 64h, Ins ID: 608Fh, Attr ID: 1).

19. EtherNet/IP COMMUNICATION

(3) Gear ratio (6091h)

Ins ID	Attr ID	Access	Name	Data Type
6091h	0	Get	Gear ratio	USINT
	1	Get/Set	Motor revolutions	UDINT
	2		Shaft revolutions	

Ins ID	Attr ID	Default	Range	Units	EEP-ROM	Parameter
6091h	0	2	02h to 02h		Impossible	
	1	1	00000001h to 00FFFFFFh (16777215)	rev	Possible	PA06
	2					PA07

Set the electronic gear. Refer to [Pr. PA06] for the settable values.

(4) Feed constant (6092h)

Ins ID	Attr ID	Access	Name	Data Type
6092h	0	Get	Feed constant	USINT
	1	Get/Set	Feed	UDINT
	2		Shaft revolutions	

Ins ID	Attr ID	Default	Range	Units	EEP-ROM	Parameter
6092h	0	2	02h to 02h		Impossible	
	1		Refer to the text.	pos units		
	2	1		rev		

No value can be written because Feed (Class ID: 64h, Ins ID: 6092h, Attr ID: 1) and Shaft revolutions (Class ID: 64h, Ins ID: 6092h, Attr ID: 2) are set automatically with the control mode, [Pr. PT01] and [Pr. PT03]. Writing a value sets a general-purpose code 09h Invalid attribute value.

[Pr. PT01] setting	[Pr. PT03] setting	Range	
		Feed	Shaft revolutions
_ 0 _ (mm) _ 1 _ (inch)	___ 0	Encoder resolution of the servo motor	1
	___ 1		10
	___ 2		100
	___ 3		1000
_ 2 _ (degree)	___ 0 to ___ 3	360000	1
_ 3 _ (pulse)		Encoder resolution of the servo motor	

Position actual value (Class ID: 64h, Ins ID: 6064h, Attr ID: 0) is calculated from Gear ratio (Class ID: 64h, Ins ID: 6091h) and Feed constant (Class ID: 64h, Ins ID: 6092h), as follows.

Position actual value (64h, 6064h, 0)

$$= \frac{\text{Position actual internal value (64h, 6063h, 0)} \times \text{Feed constant (64h, 6092h)}}{\text{Position encoder resolution (64h, 608Fh)} \times \text{Gear ratio (64h, 6091h)}}$$

Each value in () of the formula indicates Class ID, Ins ID, and Attr ID from the left. When the unit is degree, the operation result will be limited within 0 to 359999.

19. EtherNet/IP COMMUNICATION

(5) SI unit position (60A8h)

Ins ID	Attr ID	Access	Name	Data Type
60A8h	0	Get/Set	SI unit position	UDINT

Ins ID	Attr ID	Default	Range	Units	EEP-ROM	Parameter
60A8h	0	0	Refer to the text.	pos units	Impossible	

SI unit position (Class ID: 64h, Ins ID: 60A8h, Attr ID: 0) is set automatically with the control mode, [Pr. PT01] and [Pr. PT03].

[Pr. PT01] setting	[Pr. PT03] setting	Range
_ 0 _ _ (mm)	___ 0 (x 1)	FA010000h (0.001 mm)
	___ 1 (x 10)	FB010000h (0.01 mm)
	___ 2 (x 100)	FC010000h (0.1 mm)
	___ 3 (x 1000)	FD010000h (1 mm)
_ 1 _ _ (inch)	___ 0 (x 1)	FCC00000h (0.0001 inch)
	___ 1 (x 10)	FDC00000h (0.001 inch)
	___ 2 (x 100)	FEC00000h (0.01 inch)
	___ 3 (x 1000)	FFC00000h (0.1 inch)
_ 2 _ _ (degree)	___ 0 to ___ 3	FD410000h (0.001 degree)
_ 3 _ _ (pulse)		00000000h (1 pulse)

(6) SI unit velocity (60A9h)

Ins ID	Attr ID	Access	Name	Data Type
60A9h	0	Get/Set	SI unit velocity	UDINT

Ins ID	Attr ID	Default	Range	Units	EEP-ROM	Parameter
60A9h	0	0	FB010300h (0.01 mm/s) FEB44700h (0.01 r/min)	vel units	Impossible	

The SI unit velocity is returned.

19. EtherNet/IP COMMUNICATION

19.7.3.15 Touch Probe Function Objects (Class ID: 64h)

The instances described in this section support the following service.

- When "Get" is in the "Access" field

Service Code	Name	Description
0Eh	Get_Attribute_Single	Reads the value of the specified attribute.

- When "Set" is in the "Access" field

Service Code	Name	Description
10h	Set_Attribute_Single	Writes a value to the specified attribute.

- When "Get/Set" is in the "Access" field

Service Code	Name	Description
0Eh	Get_Attribute_Single	Reads the value of the specified attribute.
10h	Set_Attribute_Single	Writes a value to the specified attribute.

(1) Touch probe function (60B8h)

Ins ID	Attr ID	Access	Name	Data Type
60B8h	0	Get/Set	Touch probe function	UINT

Ins ID	Attr ID	Default	Range	Units	EEP-ROM	Parameter
60B8h	0	0	0000h to FFFFh		Impossible	

Set the command for the touch probe function. Refer to section 5.5 (1) (a) for details.

(2) Touch probe status (60B9h)

Ins ID	Attr ID	Access	Name	Data Type
60B9h	0	Get	Touch probe status	UINT

Ins ID	Attr ID	Default	Range	Units	EEP-ROM	Parameter
60B9h	0		0000h to FFFFh		Impossible	

The status of the touch probe function is returned. Refer to section 5.5 (1) (b) for details.

(3) Touch probe pos1 pos value (60BAh)

Ins ID	Attr ID	Access	Name	Data Type
60BAh	0	Get	Touch probe pos1 pos value	DINT

Ins ID	Attr ID	Default	Range	Units	EEP-ROM	Parameter
60BAh	0	0	80000000h to 7FFFFFFFh	pos units	Impossible	

The position latched at the rising edge of touch probe 1 is returned.

19. EtherNet/IP COMMUNICATION

(4) Touch probe pos1 neg value (60BBh)

Ins ID	Attr ID	Access	Name	Data Type
60BBh	0	Get	Touch probe pos1 neg value	DINT

Ins ID	Attr ID	Default	Range	Units	EEP-ROM	Parameter
60BBh	0	0	80000000h to 7FFFFFFFh	pos units	Impossible	

The position latched at the falling edge of touch probe 1 is returned.

(5) Touch probe pos2 pos value (60BCh)

Ins ID	Attr ID	Access	Name	Data Type
60BCh	0	Get	Touch probe pos2 pos value	DINT

Ins ID	Attr ID	Default	Range	Units	EEP-ROM	Parameter
60BCh	0	0	80000000h to 7FFFFFFFh	pos units	Impossible	

The position latched at the rising edge of touch probe 2 is returned.

(6) Touch probe pos2 neg value (60BDh)

Ins ID	Attr ID	Access	Name	Data Type
60BDh	0	Get	Touch probe pos2 neg value	DINT

Ins ID	Attr ID	Default	Range	Units	EEP-ROM	Parameter
60BDh	0	0	80000000h to 7FFFFFFFh	pos units	Impossible	

The position latched at the falling edge of touch probe 2 is returned.

19. EtherNet/IP COMMUNICATION

19. 7. 3. 16 Optional application FE Objects (Class ID: 64h)

The instances described in this section support the following service.

Service Code	Name	Description
0Eh	Get_Attribute_Single	Reads the value of the specified attribute.

(1) Digital inputs (60FDh)

Ins ID	Attr ID	Access	Name	Data Type
60FDh	0	Get	Digital inputs	UDINT

Ins ID	Attr ID	Default	Range	Units	EEP-ROM	Parameter
60FDh	0		00000000h to 037E0007h		Impossible	

The on/off states of the input device connected to the driver are returned.

19. EtherNet/IP COMMUNICATION

Bit	Reading connector pin No.	Initial device	Input device changing parameter (Note 2)	Status reading selection parameter (Note 3)	LSP/LSN output reversing parameter (Note 4)	Description
0					PC76	Negative limit switch [Pr. PA14] = 0 0: LSN (Reverse rotation stroke end) off 1: LSN (Reverse rotation stroke end) on [Pr. PA14] = 1 0: LSP (Forward rotation stroke end) off 1: LSP (Forward rotation stroke end) on
1					PC76	Positive limit switch [Pr. PA14] = 0 0: LSP (Forward rotation stroke end) off 1: LSP (Forward rotation stroke end) on [Pr. PA14] = 1 0: LSN (Reverse rotation stroke end) off 1: LSN (Reverse rotation stroke end) on
2						home switch 0: DOG (Proximity dog) off 1: DOG (Proximity dog) on
3 to 16						(reserved) The value at reading is undefined.
17	CN3-2	LSP	PD03	PC79	PC76 (Note 5)	DI1 0: Off 1: On
18	CN3-12	LSN	PD04	PC79	PC76 (Note 5)	DI2 0: Off 1: On
19	CN3-19	DOG	PD05	PC79	PC76 (Note 5)	DI3 0: Off 1: On
20	CN3-10	TPR1	PD38	PC79		DI4 0: TPR1 (Touch probe 1) off 1: TPR1 (Touch probe 1) on
21	CN3-1	TPR2		PC79		DI5 0: TPR2 (Touch probe 2) off 1: TPR2 (Touch probe 2) on
22	CN3-20	EM2	PA04	PC79		EM2/EM1 0: Off 1: On
23						(reserved) The value at reading is undefined.
24	CN8-4					Safe torque off 1 0: STO1 off 1: STO1 on
25	CN8-5					Safe torque off 2 0: STO2 off 1: STO2 on
26 to 31						(reserved) The value at reading is undefined.

2. You can change input devices of the pin with this parameter setting. When [Pr. PD03] to [Pr. PD05] are set to "_ _ 0 0", the ON/OFF state of each pin is returned.
3. With this parameter setting, you can specify whether the ON/OFF states of the input devices are returned or the ON/OFF states of the pins are returned.
4. You can reverse the output with this parameter setting.
5. This parameter is available when [Pr. PC79] is set to "0" (the ON/OFF states of the input devices are returned) while LSP or LSN is assigned to each pin.

19. EtherNet/IP COMMUNICATION

(2) Digital outputs (60FEh)

Ins ID	Attr ID	Access	Name	Data Type
60FE	0	Get	Number of entries	USINT
	1	Get/Set	Physical outputs	UDINT
	2		Bit mask	

Ins ID	Attr ID	Default	Range	Units	EEP-ROM	Parameter
60FE h	0	2	02h to 02h		Impossible	
	1	0	00000000h to 000E0000h			
	2	0				

Set the ON/OFF states of the output devices connected to the driver.
This object is available with drivers.

(a) Physical outputs (Class ID: 64h, Ins ID: 60FEh, Attr ID: 1)

Bit	Description
0 to 16	(reserved) The value at reading is undefined. Set "0" when writing.
17	DO1 0: DOA (General-purpose output A) off 1: DOA (General-purpose output A) on When using this bit, assign DOA (General-purpose output A) to CN3-9, CN3-13 or CN3-15 pin in [Pr. PD07] to [Pr. PD09].
18	DO2 0: DOB (General-purpose output B) off 1: DOB (General-purpose output B) on When using this bit, assign DOB (General-purpose output B) to CN3-9, CN3-13 or CN3-15 pin in [Pr. PD07] to [Pr. PD09].
19	DO3 0: DOC (General-purpose output C) off 1: DOC (General-purpose output C) on When using this bit, assign DOC (General-purpose output C) to CN3-9, CN3-13 or CN3-15 pin in [Pr. PD07] to [Pr. PD09].
20 to 31	(reserved) The value at reading is undefined. Set "0" when writing.

(b) Bit mask (Class ID: 64h, Ins ID: 60FEh, Attr ID: 2)

Bit	Description
0 to 16	(reserved) The value at reading is undefined. Set "0" when writing.
17	DO1 0: DOA (General-purpose output A) disabled 1: DOA (General-purpose output A) enabled When this bit is set to "0", bit 17 of the Physical outputs is always "0".
18	DO2 0: DOB (General-purpose output B) disabled 1: DOB (General-purpose output B) enabled When this bit is set to "0", bit 18 of the Physical outputs is always "0".
19	DO3 0: DOC (General-purpose output C) disabled 1: DOC (General-purpose output C) enabled When this bit is set to "0", bit 19 of the Physical outputs is always "0".
20 to 31	(reserved) The value at reading is undefined. Set "0" when writing.

20. PROFINET COMMUNICATION

20	PROFINET COMMUNICATION	3
20.1	PROFINET COMMUNICATION	3
20.1.1	Description	3
20.1.2	Communication specifications	5
20.1.3	Startup	6
20.1.4	Network disconnection procedure	7
20.1.5	Object dictionary (OD)	7
20.1.5.1	Section definition of object dictionary	7
20.2	PROFINET NETWORK CARD (LEC-S-NP)	8
20.2.1	Specifications	8
20.2.2	Parts identification	8
20.2.3	LED display	9
20.2.3.1	Network Status LED	9
20.2.3.2	Card Status LED	9
20.2.3.3	Link/Activity LED	9
20.2.4	Ethernet cable connection	10
20.3	PROCESS DATA (CYCLIC DATA EXCHANGE)	11
20.4	ACYCLIC DATA EXCHANGE	15
20.4.1	Acyclic data exchange communication format	15
20.4.2	Error number	16
20.4.3	PROFIdrive parameters (PROFIdrive-specific)	16
20.4.3.1	Telegram Selection (P922)	17
20.4.3.2	Operating mode (P930)	17
20.4.3.3	Fault message counter (P944)	17
20.4.3.4	Fault number (P947)	18
20.4.3.5	Drive Unit identification (P964)	18
20.4.3.6	Profile identification number (P965)	18
20.4.3.7	DO identification (P975)	19
20.4.3.8	Parameter Database Handling and Identification (P980)	19
20.4.4	Identification & Maintenance (I&M)	20
20.4.5	Reset To Factory	21
20.5	STATE TRANSITION	22
20.5.1	Basic State Machine	22
20.5.2	FSA state	25
20.5.3	Controlword/Statusword	27
20.5.3.1	Controlword	27
20.5.3.2	Statusword	30
20.6	CONTROL MODE	36
20.6.1	Selection of control mode	36
20.6.2	Control switching	37
20.6.3	Profile position mode (pp)	37
20.6.4	Profile velocity mode (pv)	42
20.6.5	Profile torque mode (tq)	48
20.6.6	Homing mode (hm)	51
20.6.7	Point table mode (pt)	79
20.6.8	Indexer mode (idx)	84
20.6.9	Jog mode (jg)	91
20.7	WEB SERVER	97
20.8	MANUFACTURER FUNCTIONS	98
20.8.1	PROFIdrive parameters for status monitor	98
20.8.2	Stroke end	100
20.8.3	Software limit	101
20.8.4	Torque limit	102
20.8.5	Polarity	103

20. PROFINET COMMUNICATION

20.8.6	Touch probe.....	104
20.8.7	One-touch tuning.....	109
20.8.8	Driver life diagnosis function	110
20.8.9	Machine diagnosis	111
20.8.10	Quick stop.....	112
20.8.11	Halt.....	113
20.8.12	Ramp Stop.....	113
20.8.13	PROFIdrive parameter definitions related to alarms.....	114
20.8.14	Parameter.....	115
20.8.14.1	Parameter enabling.....	116
20.8.15	Degree function.....	117
20.9	OBJECT DICTIONARY	119
20.9.1	Store parameters	119
20.9.2	PROFIdrive parameter (Manufacturer-specific) list.....	120
20.9.3	PROFIdrive parameter (Manufacturer-specific).....	124
20.9.3.1	General Objects.....	124
20.9.3.2	Servo Parameter Objects.....	125
20.9.3.3	Alarm Objects.....	128
20.9.3.4	Monitor Objects.....	130
20.9.3.5	Manufacturer Specific Control Objects.....	143
20.9.3.6	PDS Control Objects	151
20.9.3.7	Position Control Function Objects	154
20.9.3.8	Profile Velocity Mode Objects.....	156
20.9.3.9	Profile Torque Mode Objects	158
20.9.3.10	Profile Position Mode Objects.....	160
20.9.3.11	Homing Mode Objects	164
20.9.3.12	Point Table Mode Objects	168
20.9.3.13	Factor Group Objects	171
20.9.3.14	Optional application FE Objects	173
20.9.3.15	Touch Probe Function Objects.....	175

20. PROFINET COMMUNICATION

20 PROFINET COMMUNICATION

20.1 PROFINET COMMUNICATION

20.1.1 Description

PROFINET represents the communication standard for the automation which was made by PI (PROFIBUS & PROFINET International).

The PROFINET IO communication is available when the PROFINET network card (LEC-S-NP) is connected to the_driver. The driver to which the PROFINET network card is connected is an IO device.

It supports two cyclic communication formats conforming to PROFIdrive profile and CiA 402 drive profile. It is compatible with the following control modes. Refer to chapter 6 for details.

Please download the configuration file (GSD file) from SMC website.

Control mode	Symbol	Description
Profile position mode	pp	This is a positioning control mode where an end position command is received to drive the servo motor in the commutation with a upper side. Use an absolute position address or relative position address for a command.
Profile velocity mode	pv	This is a control mode where a target speed command is received to drive the servo motor in the communication with a upper side.
Profile torque mode	tq	This is a control mode where a target torque command is received to drive the servo motor in the communication with a upper side.
Homing mode	hm	This is a control mode where the driver performs a home position return using the method directed by the upper side.
Point table mode	pt	This is a positioning operation mode where the servo motor is driven according to the commands of the travel distance, speed command and others stored in the specified point table No. in the commutation with a upper side.
Jog mode	jg	This is a control mode where the servo motor speed is set to drive the servo motor manually in the commutation with a upper side.
Indexer mode	idx	This is a positioning operation mode where the servo motor is driven to the specified station in the communication with a upper side.

_ drivers comply with the following standards. Refer to the following standards for the description not written in this Instruction Manual.

Document	Version
Profile Drive Technology PROFIdrive Technical Specification	V4.1
Profiles for decentralized periphery Technical Specification for PROFINET IO	V2.3Ed2
Application Layer protocol for decentralized periphery Technical Specification for PROFINET IO	V2.3Ed2
Application Layer services for decentralized periphery Technical Specification for PROFINET IO	V2.3Ed2

20. PROFINET COMMUNICATION

The following table shows explanation of terms applied to PROFINET standard used in this manual.

Term	Explanation
PROFINET (PROFINET IO)	PROFINET has two application types: PROFINET IO and PROFINET CBA. This product is compatible with PROFINET IO. PROFINET IO is based on a communication between upper sides and other devices. PROFINET CBA is based on a communication between upper sides with components.
PROFIdrive	This is an application profile defined with PROFINET and PROFIBUS for electric-powered drives such as drivers. The communication data format and functional range are provided.
RT, IRT	These are the communication methods of Process Data (cyclic communication) for PROFINET IO. RT means Real-Time (asynchronous communication) and IRT means Isochronous Real-Time (synchronous communication).
Process Data	This is the name of cyclic communication data (Cyclic Data Exchange) for PROFINET communication. This is also called I/O data. The data format of cyclic communication is called Telegram in this manual.
Acyclic communication (Acyclic Data Exchange)	This is the name of acyclic communication (request/response pattern) for PROFINET communication.
GSD file	This is the XML format file (GSDML file) of communication specifications and characteristics supported with this product. Use this when you set up this product (selection of Telegram and setting of transmission cycle) with the PROFINET configuration tool.
PNU	This is an abbreviation for parameter number used in PROFINET communication. The network variables used in PROFINET communication are described as PROFIdrive parameters and the parameters of drivers are described as parameters (or servo parameters). The PROFIdrive parameters are described as follows. Example) PROFIdrive parameter 922 → P922
Array [n]	The PROFIdrive parameter whose Data Type is "Array [n]" is in an array structure and subindex (Sub) will be used to access each element in the array. The subindices of PROFIdrive parameters are described as follows. Example) PROFIdrive parameter 980, subindex 2 → P980.2
AR, CR	These are AR (Application Relationship) and CR (Communication Relationship). AR is established between the upper side and device. Each CR (IO CR for cyclic communication and Record Data CR for acyclic communication) in AR will transmit/receive data.
R, W, R/W	The following shows description of Access. R: Readable W: Writable R/W: Readable and writable

20. PROFINET COMMUNICATION

20.1.2 Communication specifications

The following shows the communication specifications.

Item	Description	Remark
PROFINET communication specifications	PROFINET IO Real Time (RT) communication PROFIdrive v4.1	
Physical layer	100BASE-TX	
Communication connector	RJ45, 2 ports (port 1, port 2)	
Communication cable	CAT5e, shielded twisted pair (4 pair) straight cable	Double-shielded type recommended
Network topology	Line, Star, Ring, or a connection topology where the topologies are used together	
Variable communication speed	100 Mbps (Full duplex)	
Transmission speed between stations	Max. 100 m	
Number of nodes	Compliant with the specifications of the standard Ethernet	
Conformance class	Conformance class B (CC-B)	
Real time class	RT_Class_1	
Acyclic Data Exchange	Transmitting/Receiving: 1 channel each	
Process Data (Cyclic Data Exchange)	Transmission cycle: 1, 2, 4, 8, 16, 32, 64, 128, 256, 512 ([ms]) Variable mapping: compatible	Transmission cycle = $31.25 \mu\text{s} \times \text{SendClockFactor} \times \text{ReductionRatio}$ ReductionRatio Setting range of SendClockFactor (= 32) Setting range of ReductionRatio (= 1, 2, 4, 8, 16, 32, 64, 128, 256, 512) Variable mapping Telegram 102: Maximum size: 48 bytes each transmitting/receiving Maximum number of mapping: 24 each transmitting/receiving Telegram 103: Maximum size: 60 bytes each transmitting/receiving Maximum number of mapping: 30 each transmitting/receiving
Byte order	Big endian	
LED display	Network Status, Card Status, LINK/Activity (port 1, port 2)	

20. PROFINET COMMUNICATION

20.1.3 Startup

The following describes the setting and startup of the PROFINET communication. Refer to section 4.1 for the startup procedure other than the network setting.

(1) Connection with the upper side

Set up the upper side following the manual of the upper side used. For the setup, the General Station Description (GSD) file listing the information about the communication setting of devices is available. Install the EDS file to a configuration tool to be used. Refer to the manual of each configuration tool for how to use the GSD file.

(2) Station name

This is used for identifying of driver from the upper side. Set up the upper side following the manual of the upper side used.

(3) Parameter setting

Set the control mode with [Pr. PA01 Operation mode]. Refer to section 5.2.1 for the parameter setting.

(4) IP address setting

Set an IP address using the "AnybusIPconfig" tool offered, axis selection rotary switch (SW2/SW3) on the display of the driver, and upper side. Change the IP address with the axis selection rotary switch (SW2/SW3) before powering on the driver. When you set it with automatic setting of the upper side, the upper side setting will be prioritized. The IP address you set can be checked with the "AnybusIPconfig" tool or system configuration window of Setup software (MR Configurator2™). You can set an IP address as follows.

Axis selection rotary switch (SW2/SW3)	IP address setting value
00h	An IP address set by the "AnybusIPconfig" tool is used.
01h to FEh	Although an IP address set by the "AnybusIPconfig" tool is used, the forth octet value is replaced with a value set with the axis selection rotary switch (SW2/SW3). The DHCP function is disabled. Set a hexadecimal value with the axis selection rotary switch (SW2/SW3). The hexadecimal value is converted into a decimal value and set as the fourth octet of the IP address.
FFh	The DHCP function is enabled.

(5) Setting tool

The following lists the tools used for starting up.

Tool	Explanation	Manufacturer
Setup software (MR Configurator2™)	This software is used to configure various settings of the driver and helps maintenance works.	
AnybusIPconfig	This tool is used to set an IP address to the PROFINET network card (LEC-S-NP).	Please download the IPConfigTool from SMC website.

20. PROFINET COMMUNICATION

20.1.4 Network disconnection procedure

To disconnect the network by stopping device operation or other means, follow the procedure shown below.

- (1) When the servo motor is during operation, stop the servo motor depending on the operation mode.
- (2) When the driver is in servo-on status, set the off command for Controlword to establish the servo-off status.
- (3) Stop the Process Data communication referring to the instruction manual of upper side.
- (4) Shut off the power of the driver and upper side.

20.1.5 Object dictionary (OD)

This product supports object dictionary which conforms to CiA 402 Drive Profile and converts PROFIdrive parameter number (PNU) to index number to access each entry in the object dictionary.

Each data set that devices have such as control parameters, command values, and feedback values is handled as an object composed of an object name, object type, data type, and other elements. The object data can be exchanged between the master and slave devices. The aggregate of these objects is called object dictionary (OD).

20.1.5.1 Section definition of object dictionary

The object dictionary is categorized by PNU depending on the contents of data as shown in the following table.

The object group of Manufacturer-specific is defined between P1000 and P59999. All of the other objects comply with definitions of the PROFIdrive standard. The following correspondence table shows PNU and description of objects. Refer to the Reference column for the chapters and the section where the details of each object are described.

Section definition of object dictionary

PNU	Description	Reference
900 to 999	PROFIdrive-specific parameters	Section 4.3
4096 to 59999	Manufacturer-specific PROFIdrive parameters (including object group provided in CiA 402 Drive Profile)	Section 9.3

Outline of Manufacturer-specific PROFIdrive parameters

PNU	Description	Index No. of CiA 402 standard	Reference
4096 to 8191	CoE communication area	1000h to 1FFFh	Section 8.14, chapter 9
8192 to 10239	Parameter	2000h to 25FFh	Section 8.14, chapter 9
10240 to 10751	Point table	2800h to 29FFh	Chapter 9
10752 to 10879	Servo control command/monitor	2A00h to 2FFFh	Chapter 6, chapter 9
24576 to 28671	CiA 402 drive profile area	6000h to 6FFFh	Chapter 5, chapter 6, chapter 9

20. PROFINET COMMUNICATION

20.2 PROFINET NETWORK CARD (LEC-S-NP)

The PROFINET communication with an _ driver requires the PROFINET network card (LEC-S-NP). The following shows the details.

20.2.1 Specifications

Category	Description
Network card	LEC-S-NP
Product name	ABCC-M40-PIR
Model	AB6938-C-139
Manufacturer	HMS Industrial Networks
External interface	driver connecting interface: Compact flash connector with standard 50 pins PROFINET communication port interface: RJ45 connector
Dimensions	52 (W) × 50 (D) × 20 (H) Except the protrusion of the PROFINET communication port connector
Mass	Approx. 30 g

20.2.2 Parts identification

This section describes the PROFINET network card (LEC-S-NP) only. Refer to section 1.7 for the driver.

No.	Name/Application	Detailed explanation
(1)	Card Status LED Indicates the card status.	Section 2.2.2
(2)	RJ45 PROFINET communication port (port 2) Connect the upper side or driver.	Section 2.3
(3)	Link/Activity LED (port 2) Indicates the link status of each PROFINET communication port.	Section 2.2.3
(4)	RJ45 PROFINET communication port (port 2) Connect the upper side or driver.	Section 2.3
(5)	Link/Activity LED (port 1) Indicates the link status of each PROFINET communication port.	Section 2.2.3
(6)	Network Status LED Indicates the communication status.	Section 2.2.1

20. PROFINET COMMUNICATION

20.2.3 LED display

The PROFINET Network card (LEC-S-NP) has each LED of the Network Status, Card Status, and Link/Activity.

The following shows the LED indication definitions.

LED status	Definition
Lit	An LED remains lit.
Extinguished	An LED remains extinguished.
Flickering	An LED is switching between lit and extinguished at 10 Hz cycles (every 50 ms).
Blinking	For 3 s, an LED is switching between lit and extinguished at 1 Hz cycles (every 500 ms).
Single flash	An LED is lit for 200 ms and extinguished 1000 ms repeatedly.
Double flash	An LED is lit for 200 ms, extinguished for 200 ms, lit for 200 ms, and extinguished for 1000 ms repeatedly.
Triple flash	An LED is lit for 200 ms, extinguished for 200 ms, lit for 200 ms, extinguished for 200 ms, lit for 200 ms, and extinguished for 1000 ms repeatedly.

20.2.3.1 Network Status LED

The Network Status LED indicates the PROFINET communication status. When Network Status LED is extinguished, the LED may be influenced by Link/Activity LED.

LED status	Description
Extinguished	Indicates that the power is shut off or connection with the upper side has not been established.
Lit in green	Indicates that connection with the upper side has been established and the upper side is in RUN status.
Single flash in green	Indicates that connection with the upper side has been established and the upper side is in STOP status or the communication data is incorrect.
Blinking in green	Indicates that the engineering tool is checking a node on network.
Lit in red	Indicates that a serious malfunction that cannot be restored has been detected. This will light simultaneously with Card Status LED in red.
Single flash in red	Indicates that a station name has not been set.
Double flash in red	Indicates that an IP address has not been set.
Triple flash in red	Indicates that identification information differs between upper side and device. It means a configuration error.

20.2.3.2 Card Status LED

The Card Status LED indicates the status of device and an error in the PROFINET communication.

LED status	Description
Extinguished	Indicates that the power is shut off or initialization has not been completed.
Lit in green	Indicates that initialization of the network card has been completed and the card operates normally.
Single flash in green	Indicates that the network card is diagnosing itself.
Lit in red	Indicates that an exception error has detected in the network card. Indicates that a serious malfunction that cannot be restored has been detected. This will light simultaneously with Network Status LED in red.

20.2.3.3 Link/Activity LED

The Link/Activity LEDs indicate the link status of each PROFINET communication port.

LED status	Description
Extinguished	Indicates that the power supply is shut off or the link-unestablished state.
Lit in green	Indicates that the link is established without traffic.
Flickering in green	Indicates that the link is established with traffic.

20. PROFINET COMMUNICATION

20.2.4 Ethernet cable connection

POINT

- Use a twisted pair cable (double shielded) compliant with Ethernet Category 5e (100BASE-TX) or higher as an Ethernet cable. The maximum cable length between nodes is 100 m.

When the RJ45 PROFINET communication ports (port 1 and port 2) are not used, leave these ports open.

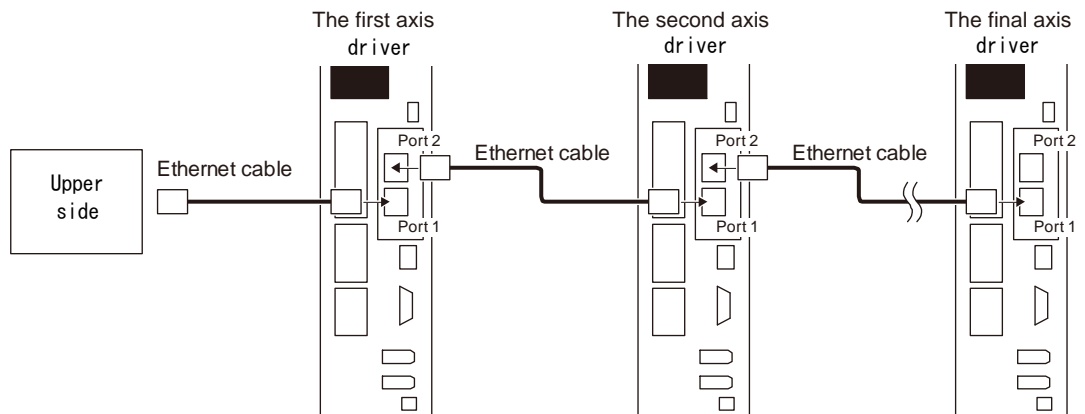

20. PROFINET COMMUNICATION

20.3 PROCESS DATA (CYCLIC DATA EXCHANGE)

The communication can send and receive command data/feedback data between a master (upper side) and slaves (driver) at a constant cycle.

The following communication format is supported.

Telegram	Name	Description
1	Standard Telegram 1 (compliant with PROFIdrive)	This is for applications using speed control.
100	Telegram 100 (Manufacturer-specific format)	This is for applications using torque control.
102	Telegram 102 (Manufacturer-specific format)	This is for applications using position control, speed control, torque control, and home position return switching. This is compatible with variable mapping.
103	Telegram 103 (Manufacturer-specific format)	This is for applications using the point table mode, Jog mode and the home position return mode switched, or for applications using the indexer mode, Jog mode and home position return mode switched. This is compatible with variable mapping.

Note. Each telegram is selected with a configuration tool of upper side. Refer to section 6.1 for the control mode compatible with each telegram.

(1) Standard Telegram 1

Direction	IO Data number	Name	Symbol	Data length (Bit)	Remark
Upper side to Drive	1	Control word 1	STW1	16	Refer to chapter 5/ chapter 6.
	2	Speed setpoint A	NSOLL_A	16	
Drive to Upper side	1	Status word 1	ZSW1	16	
	2	Speed actual value A	NIST_A	16	

(2) Telegram 100

Direction	IO Data number	Name	Data length (Bit)	Remark
Upper side to Drive	1	Controlword	16	Refer to chapter 6.
	2	Target torque	16	
Drive to Upper side	1	Statusword	16	Refer to chapter 6.
	2	Torque actual value	16	

20. PROFINET COMMUNICATION

(3) Telegram 102

Direction	IO Data number	Name	Data length (Bit)	Remark
Upper side to Drive	1	Modes of operation	8	Refer to chapter 5 and chapter 6. Map size: 48 bytes (Note)
		Reserved	8	
	2	Controlword	16	
	3	Control DI 1	16	
	4	Control DI 2	16	
	5	Control DI 3	16	
	6	Target torque	16	
	7	Torque slope	32	
	8			
	9	Target position	32	
	10			
	11	Target velocity	32	
	12			
	13	Velocity limit value	32	
	14			
	15	Profile velocity	32	
	16			
	17	Profile acceleration	32	
	18			
	19	Profile deceleration	32	
	20			
	21	Touch probe function	16	
	22	Reserved	16	
	23	Reserved	16	
24	Reserved	16		
Drive to Upper side	1	Modes of operation display	8	Refer to chapter 5 and chapter 6. Map size: 48 bytes (Note)
		Reserved	8	
	2	Statusword	16	
	3	Status DO 1	16	
	4	Status DO 2	16	
	5	Status DO 3	16	
	6	Torque actual value	16	
	7	Digital inputs	32	
	8			
	9	Position actual value	32	
	10			
	11	Velocity actual value	32	
	12			
	13	Following error actual value	32	
	14			
	15	Touch probe pos1 pos value	32	
	16			
	17	Touch probe pos1 neg value	32	
	18			
	19	Touch probe pos2 pos value	32	
	20			
	21	Touch probe pos2 neg value	32	
	22			
	23	Touch probe status	16	
24	Reserved	16		

Note. When changing a mapping, set the total size 48 bytes. Use Reserve (PNU = 0) to adjust mapping size. To change a data length (Bit), set "0", "8", or "16" to subIndex for Reserve.

20. PROFINET COMMUNICATION

(4) Telegram 103

Direction	IO Data number	Name	Data length (Bit)	Remark
Upper side to Drive	1	Modes of operation	8	Refer to chapter 5 and chapter 6. Map size: 60 bytes (Note)
		Reserved	8	
	2	Controlword	16	
	3	Control DI 1	16	
	4	Control DI 2	16	
	5	Control DI 3	16	
	6	Target point table	16	
	7	Profile velocity	32	
	8			
	9	Profile acceleration	32	
	10			
	11	Profile deceleration	32	
	12			
	13	Touch probe function	16	
	14	Reserved	16	
	15	Reserved	16	
	16	Reserved	16	
	17	Reserved	16	
	18	Reserved	16	
	19	Reserved	16	
	20	Reserved	16	
	21	Reserved	16	
	22	Reserved	16	
	23	Reserved	16	
	24	Reserved	16	
	25	Reserved	16	
	26	Reserved	16	
	27	Reserved	16	
	28	Reserved	16	
	29	Reserved	16	
30	Reserved	16		
Drive to Upper side	1	Modes of operation display	8	Refer to chapter 5 and chapter 6. Map size: 60 bytes (Note)
		Reserved	8	
	2	Statusword	16	
	3	Status DO 1	16	
	4	Status DO 2	16	
	5	Status DO 3	16	
	6	Status DO 5	16	
	7	Status DO 7	16	
	8	Torque actual value	16	
	9	Digital inputs	32	
	10			
	11	Position actual value	32	
	12			
	13	Velocity actual value	32	
	14			
	15	Following error actual value	32	
	16			
	17	Point demand value	16	
	18	Point actual value	16	
	19	M code actual value	8	
Reserved		8		
20	Reserved	16		

20. PROFINET COMMUNICATION

Direction	IO Data number	Name	Data length (Bit)	Remark
Drive to Upper side	21	Touch probe pos1 pos value	32	Refer to chapter 5 and chapter 6. Map size: 60 bytes (Note)
	22			
	23	Touch probe pos1 neg value	32	
	24			
	25	Touch probe pos2 pos value	32	
	26			
	27	Touch probe pos2 neg value	32	
	28			
	29	Touch probe status	16	
30	Reserved	16		

Note. When changing a mapping, set the total size 60 bytes. Use Reserve (PNU = 0) to adjust mapping size. To change a data length (Bit), set SubIndex in Reserve to 0, 8, or 16.

20. PROFINET COMMUNICATION

20.4 ACYCLIC DATA EXCHANGE

20.4.1 Acyclic data exchange communication format

PROFIdrive parameters are transmitted/received between the master upper side and slave with acyclic communication.

The transmission/receive will be in accordance with the following formats. The maximum size is 240 bytes. Refer to the standards of PROFIdrive for details.

(1) Acyclic Data Exchange PROFIdrive parameter request format

Block definition	Byte n	Byte n + 1	n
Request header	Request reference	Request ID	0
	Axis-No./DO-ID	No. of parameters = i	2
1 st Parameter address	Attribute	No. of elements	4
	Parameter number (PNU)		
	Subindex		
i th Parameter address	...		4 + 6 × (i - 1)
1 st Parameter value(s) (only for request "Change parameter")	Format	No. of values	4 + 6 × i
	Values		
	...		
i th Parameter values	...		
			4 + 6 × i + ... + (Format_n × Qty_n)

(2) Acyclic Data Exchange PROFIdrive parameter response format

Block definition	Byte n	Byte n + 1	n
Response header	Request ref. mirrored	Response ID	0
	Axis-No./DO-ID mirrored	No. of parameters = i	2
1 st Parameter value(s) (only after request "Request")	Format	No. of values	4
	Values or Error values		
	...		
i th Parameter values	...		
			4 + ... + (Format_n × Qty_n)

20. PROFINET COMMUNICATION

20.4.2 Error number

The following error number will be returned depending on conditions during Acyclic communication.

Error No.	Name	Description
00h	Impermissible parameter number	Access to non-existent PROFIdrive parameter
01h	Parameter value cannot be changed	Writing to unwritable PROFIdrive parameter
02h	Low or high limit exceeded	Out of setting range
03h	Faulty subindex	Access to non-existent subindex
04h	No array	Access to PROFIdrive parameter having non-existent subindex
05h	Incorrect data type	Data type mismatch
07h	Description element cannot be changed	Changing unchangeable description element
0Fh	No text array available	Access to non-existent text
11h	Request cannot be executed because of operating state	Temporarily inaccessible due to operating state
14h	Value impermissible	Changing PROFIdrive parameter with an impermissible value
15h	Response too long	Response is over the maximum size of transmission.
16h	Parameter address impermissible	Combination of incorrect value, element No., PNU, and subindex
17h	Illegal format	Incorrect PROFIdrive parameter data format
18h	Number of values are not consistent	The number of PROFIdrive parameter values does not match the number of address elements
19h	Axis/DO nonexistent	Access to non-existent axis or object
21h	Service not supported	Out of service range (incorrect request ID)
FFh	Attempt to read to a write only parameter	Reading out write only parameter

20.4.3 PROFIdrive parameters (PROFIdrive-specific)

The following shows PROFIdrive-specific parameters supported by _ . For manufacturer-specific PROFIdrive parameters, refer to chapter 9.

PROFIdrive-specific parameter list

Group	PNU	Access	Name
PROFIdrive Parameters	922	R	Telegram Selection
	930	R	Operating mode
	944	R	Fault message counter
	947	R	Fault number
	964	R	Drive Unit identification
	965	R	Profile identification number
	975	R	DO identification
	980	R	Number list of defined parameter

20. PROFINET COMMUNICATION

20.4.3.1 Telegram Selection (P922)

PNU	Sub	Access	Name	Data Type	Description	Default
922	0	R	Tgm selection	Unsigned16	The selected Telegram is returned.	1

PNU	Sub	Range	Units	EEP-ROM	Parameter
922	0	0001h to FFFFh		Impossible	

The read values are as follows.

Value	Description
1	Standard telegram 1
100	Telegram 100
102	Telegram 102
103	Telegram 103

20.4.3.2 Operating mode (P930)

PNU	Sub	Access	Name	Data Type	Description	Default
930	0	R	Operating mode	Unsigned16	The current Operating mode is returned.	1

PNU	Sub	Range	Units	EEP-ROM	Parameter
930	0	0001h to FFFFh		Impossible	

The read values are as follows.

Value	Description
1	Speed control mode (when Standard telegram 1 is selected)
32768	Manufacturer-specific mode (when Telegram is selected other than the above)

Refer to Modes of operation display (P24673) for details of the control mode.

20.4.3.3 Fault message counter (P944)

PNU	Sub	Access	Name	Data Type	Description	Default
944	0	R	Fault counter	Unsigned16	The value of Fault message counter is returned. This value will be incremented when an alarm of driver occurs or the alarm is released.	0

PNU	Sub	Range	Units	EEP-ROM	Parameter
944	0	0000h to FFFFh		Impossible	

20. PROFINET COMMUNICATION

20.4.3.4 Fault number (P947)

The alarm occurrence of driver after power on is displayed. When the alarm does not occur, the read value of P947.0 will be "0". The error number is as follows.

PNU	Sub	Access	Name	Data Type	Description	Default
947	0	R	Fault numbers	Array [16] Unsigned16	Unacknowledged faults	0
	8	R			Acknowledged faults	0
	Other than the values above	R			Fixed to 0	0

PNU	Sub	Range	Units	EEP-ROM	Parameter
947	0 to 15	0000h to FFFFh		Impossible	

Value	Description
0x0000	None
0x0010	Generic error

For details of the occurrence of an alarm, refer to Alarm Objects (section 9.3.3).

20.4.3.5 Drive Unit identification (P964)

The identification information of drive unit is returned.

PNU	Sub	Access	Name	Data Type	Description	Default
964	0	R	Device ident	Array [5] Unsigned16	Manufacturer ID Manufacturer ID of Mitsubishi Electric	540
	1	R			Device type	0
	2	R			Firmware version The firmware version of the _ driver Example: 110 means V1.10.	
	3	R			Firmware date (year) The firmware update year of the _ driver (not supported)	0000
	4	R			Firmware date (day/month) The firmware update day/month of the _ driver (not supported)	0000

PNU	Sub	Range	Units	EEP-ROM	Parameter
964	0	0000h to FFFFh		Impossible	
	1	0000h to FFFFh		Impossible	
	2	0000h to FFFFh		Impossible	
	3	0000h to FFFFh		Impossible	
	4	0000h to FFFFh		Impossible	

20.4.3.6 Profile identification number (P965)

PNU	Sub	Access	Name	Data Type	Description	Default
965	0	R	Profile number	OctetString2	Profile Number 3	03h
	1	R			Profile Version Number 41	29h

PNU	Sub	Range	Units	EEP-ROM	Parameter
965	0	03h to 29h		Impossible	
	1	03h to 29h		Impossible	

20. PROFINET COMMUNICATION

20.4.3.7 DO identification (P975)

The identification information of drive object is returned.

PNU	Sub	Access	Name	Data Type	Description	Default
975	0	R	DO ident	Array [8] Unsigned16	Manufacturer ID Mitsubishi Electric Corporation	540
	1	R			Drive Object type	0
	2	R			Firmware version The firmware version of the _ driver Example: 110 means V1.10.	
	3	R			Firmware date (year) The firmware update year of the _ driver (not supported)	0000
	4	R			Firmware date (day/month) The firmware update day/month of the _ driver (not supported)	0000
	5	R			PROFIdrive DO type class 1: Axis	1
	6	R			PROFIdrive DO sub class 1 1: Application Class 1 supported	1
	7	R			Drive Object ID (DO-ID) Number of Drive Objects (DO)	1

PNU	Sub	Range	Units	EEP-ROM	Parameter
975	0	0000h to FFFFh		Impossible	
	1	0000h to FFFFh		Impossible	
	2	0000h to FFFFh		Impossible	
	3	0000h to FFFFh		Impossible	
	4	0000h to FFFFh		Impossible	
	5	0000h to FFFFh		Impossible	
	6	0000h to FFFFh		Impossible	
	7	0000h to FFFFh		Impossible	

20.4.3.8 Parameter Database Handling and Identification (P980)

All the supported PROFIdrive parameter numbers are listed.

PNU	Sub	Access	Name	Data Type	Description	Default
980	0 to n	R	Parameter list	Array [n] Unsigned16	Supported PROFIdrive parameter number	

PNU	Sub	Range	Units	EEP-ROM	Parameter
980	0 to n	0000h to FFFFh		Impossible	

20. PROFINET COMMUNICATION

20.4.4 Identification & Maintenance (I&M)

The information concerning I/O devices can be obtained.

The following record data can be read with the Acyclic communication.

Record	Access	Name	Data size	Description	Default	
I&M0	R	Manufacture ID	2 bytes	Mitsubishi Electric Corporation	540	
		Order ID	20 bytes	Model name of the _ driver	"MR-J4-TM"	
		Serial number	16 bytes	Serial number of the PROFINET Network card (Note)		
		Hardware revision	2 bytes	The hardware version of the _ driver		
		Software revision	4 bytes	The software version of the _ driver		
		Revision counter	2 bytes	Version counter		
		Profile ID	2 bytes	Profile ID	Slot 0	F600h
					Slot 1	3A00h
		Profile specific type	2 bytes	Profile detail	Slot 0	0004h
					Slot 1	0000h
		IM revision	2 bytes	I&M version		0101h
IM supported	2 bytes	Supported I&M		30		

Note. The serial number of _ driver can be checked with Serial Number 2 (P11571).

20. PROFINET COMMUNICATION

20.4.5 Reset To Factory

POINT
<p>● When Reset To Factory is used with a driver on which MR-D30 functional safety unit is mounted, [AL. 7A.3 Parameter combination error (safety observation function)] or [AL. 79.4 Driver error] will occur. Cycle the power of the driver.</p>

With Reset To Factory, you can reset the parameters of the device to the factory setting. Since the operation methods of Reset To Factory differs depending on configuration software, refer to the manuals for the configuration software.

Reset Option	Description
2	<p>This function resets the communication parameters to the factory setting. (Note 1)</p> <ul style="list-style-type: none"> • Reset equivalent to power off/on will be executed. • The station name will be "" (null character). • IP address will be "0.0.0.0".
8	<p>This function resets the communication parameters, driver parameters and the point table to the factory setting. Reset equivalent to power off/on will be executed.</p> <p>The station name will be "" (null character).</p> <ul style="list-style-type: none"> • IP address will be "0.0.0.0". • Parameter default will be executed. (Note 2) • Point table default will be executed. • Parameter default of MR-D30 functional safety unit will be executed.
Note 1	<p>With Reset To Factory, the values are written to EEPROM even when in Reset Option 2. Note that the number of write times to the EEPROM is limited to 100,000. If the total number of write times exceeds 100,000, the driver may malfunction when the EEPROM reaches the end of its useful life.</p>
2	<p>The following parameters will be reset;</p> <p>Basic setting parameters [Pr. PA__]</p> <ul style="list-style-type: none"> • Gain/filter setting parameters [Pr. PB__] • Extension setting parameters [Pr. PC__] (except [Pr. PC11] and [Pr. PC12]) • I/O setting parameters [Pr. PD__] • Extension setting 2 parameters [Pr. PE__] • Extension setting 3 parameters [Pr. PF__] • Linear servo motor/DD motor setting parameters [Pr. PL__] • Positioning control parameters [Pr. PT__] • Network setting parameters [Pr. PN__]

20.5 STATE TRANSITION

20.5.1 Basic State Machine

The internal state of Standard telegram 1 of the _ is controlled as follows. Figure 5.1 and Table 5.1 show the transition conditions between each state. The states are switched when the master sends a command following the table 5.1 (sets Control word 1) after the Process Data communication was established. When the state has transitioned from Switch on inhibited, which is right after the power on, to Operation with the predetermined procedure, the servo motor becomes ready to operate.

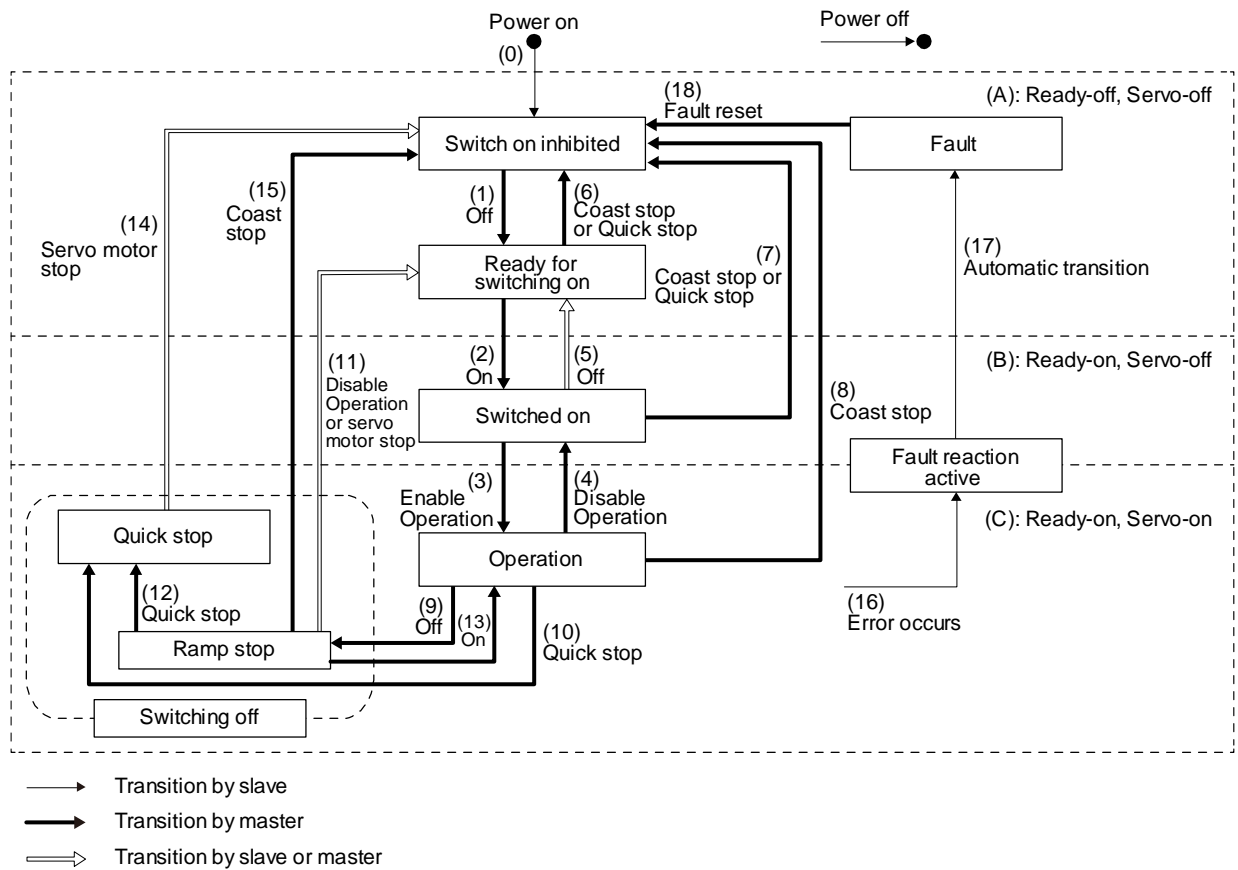

Figure 5.1 Transition between the basic states

Table 5.1 State transition

Transition No.	Event	Remark
(0)	The control circuit power supply is turned on.	Initialization
(1)	The state transitions with the Off command from the master.	None
(2)	The state transitions with the On command from the master.	RA turns on.
(3)	The state transitions with the Enable operation command from the master.	The operation becomes ready after servo-on.
(4)	The state transitions with the Disable operation command from the master.	The operation is disabled after servo-off.
(5)	The state transitions with the Off command from the master.	RA turns off.
(6)	<ul style="list-style-type: none"> - The state transitions with the Coast stop command from the master. - Quick stop command from the master 	None
(7)	<ul style="list-style-type: none"> - The state transitions with the Coast stop command from the master. - The state transitions with the Quick stop command from the master. 	RA turns off.
(8)	The state transitions with the Coast stop command from the master.	Operation is disabled after servo-off or RA-off.
(9)	The state transitions with the Off command from the master.	Ramp stop (temporary stop) starts.
(10)	The state transitions with the Quick stop command from the master.	Quick Stop starts.
(11)	<ul style="list-style-type: none"> - The state transitions after the servo motor stops. - The state transitions with the Disable operation command from the master. 	Operation is disabled after servo-off or RA-off.
(12)	The state transitions with the Quick stop command from the master.	Quick Stop starts.
(13)	The state transitions with the On command from the master.	Ramp stop (temporary stop) is canceled.
(14)	- The state transitions after the servo motor stops.	Operation is disabled after servo-off or RA-off.
(15)	The state transitions with the Coast stop command from the master.	Operation is disabled after servo-off or RA-off.
(16)	Alarm occurrence	Processing against the alarm is executed.
(17)	Automatic transition	After processing against the alarm has been completed, servo-off or RA-off is performed and the operation is disabled.
(18)	The state transitions with the Fault reset command from the master.	Alarms are reset. Resettable alarms are cleared.
-	Main circuit power supply off	Operation is disabled after servo-off or RA-off.

20. PROFINET COMMUNICATION

Correspondence relation between command bit setting and state transition.

PROFIENT Command	Command bit setting of Control word 1 (STW1, P24640) (Note)					Transition No.	CiA 402 Drive Profile command (reference)
	Bit 7	Bit 3	Bit 2	Bit 1	Bit 0		
Off	0	○	1	1	0	(1), (5), (9)	Shutdown
On	0	0	1	1	1	(2), (13)	Switch on
Coast stop	0	○	○	0	○	(6), (7), (8), (15)	Disable voltage
Quick stop	0	○	0	1	○	(6), (7), (10), (12)	Quick stop
Disable operation	0	0	1	1	1	(4), (11)	Disable operation
Enable operation	0	1	1	1	1	(3)	Enable operation
Fault reset	0 to 1	○	○	○	○	(18)	Fault reset

Note. 0: OFF 1: ON ○: ON/OFF

In faulty communication, hold the state of Bit 7 = 1 for as follows for the Fault Reset command to prevent the command from failing to be recognized.

10 ms ≥ twice the communication cycle: Hold the state for 10 ms.

10 ms < twice the communication cycle: Hold the state for the time determined by doubling the communication cycle.

Figure 5.1 and Table 5.1 show the transition conditions. The transition from the Switch on Inhibited state to the Operation state requires Off, On, and Enable operation to be issued in this order. However, with the _ driver, transition to the target state skipping the states in between is possible.

Current status	Command	Status after transition
Switch on inhibited	On	Switched on
	Enable operation	Operation
Ready for switching on	Enable operation	Operation

20.5.2 FSA state

Telegram 100 or more internal status of the driver are controlled with STA state. Figure 5.2 and Table 5.2 show the transition conditions between the FSA states. The states are switched when the master sends a command following table 5.2 (sets Controlword) after the I/O communication was established. When the state has transitioned from Not ready to switch on, which is right after the power on, to Operation enabled with the predetermined procedure, the servo motor becomes ready to operate.

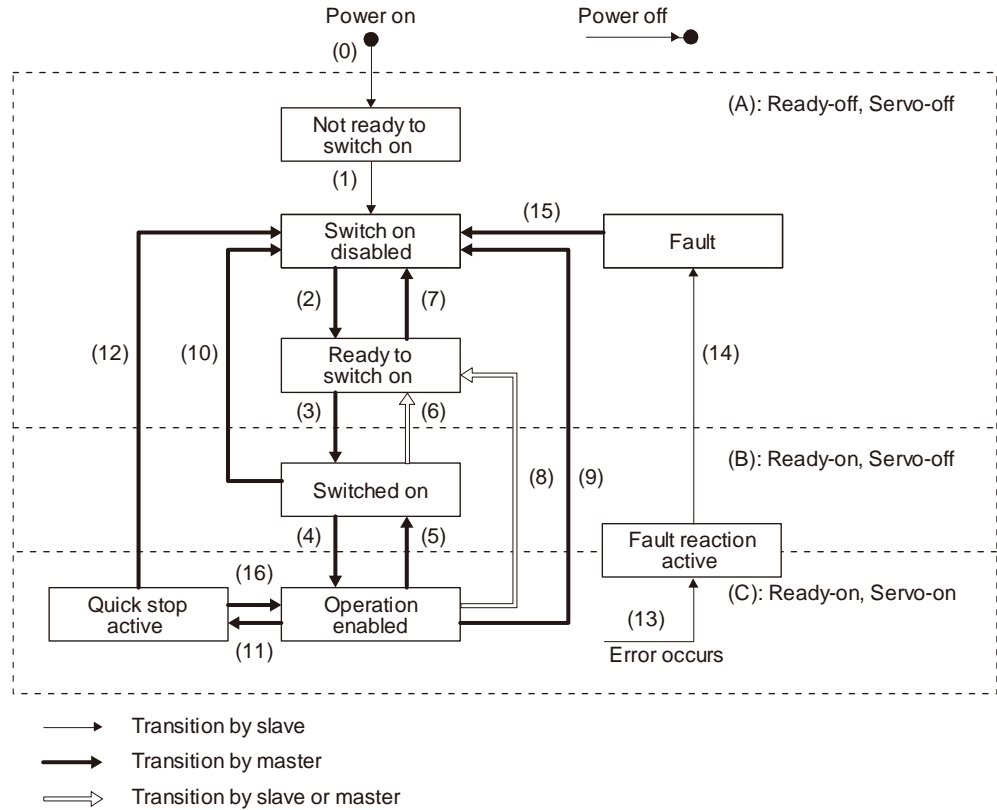

When the communication state is "IDLE", the state will always be Switch on disabled.

Figure 5.2 Transition between the FSA states

Table 5.2 State transition

Transition No.	Event	Remark
(0)	The control circuit power supply is turned on.	Initialization
(1)	The state automatically transitions when the control circuit power supply is turned on.	Communication setting
(2)	The state transitions with the Shutdown command from the master.	None
(3)	The state transitions with the Switch on command from the master.	RA turns on.
(4)	The state transitions with the Enable operation command from the master.	The operation becomes ready after servo-on.
(5)	The state transitions with the Disable operation command from the master.	The operation is disabled after servo-off.
(6)	The state transitions with the Shutdown command from the master.	RA turns off.
(7)	The state transitions with the Disable Voltage command or Quick Stop command from the master.	None
(8)	(a) The state transitions with the Shutdown command from the master. (b) The state transitions when the main circuit power supply is turned off.	Operation is disabled after servo-off or RA-off.
(9)	The state transitions with the Disable Voltage command from the master.	Operation is disabled after servo-off or RA-off.
(10)	The state transitions with the Disable Voltage command or Quick Stop command from the master.	RA turns off.
(11)	The state transitions with the Quick Stop command from the master.	Quick Stop starts.
(12)	(a) The state automatically transitions after Quick Stop is completed. (If the Quick Stop option code is 1, 2, 3, or 4) (b) The state transitions with the Disable Voltage command from the master.	Operation is disabled after servo-off or RA-off.
(13)	Alarm occurrence	Processing against the alarm is executed.
(14)	Automatic transition	After processing against the alarm has been completed, servo-off or RA-off is performed and the operation is disabled.
(15)	The state transitions with the Fault Reset command from the master.	Alarms are reset. Resettable alarms are cleared.
(16)	The state transitions with the Enable Operation command from the master. (If the Quick Stop option code is 5, 6, 7, or 8)	The operation becomes ready. (Not supported)

Correspondence relation between command bit setting and FSA state transition

Command	Command bit setting of Controlword (Note)					Transition No.
	Bit 7 Fault Reset	Bit 3 Enable Operati on	Bit 2 Quick Stop	Bit 1 Enable Voltage	Bit 0 Switch On	
Shutdown	0	○	1	1	0	(2), (6), (8)
Switch On	0	0	1	1	1	(3)
Disable Voltage	0	○	○	0	○	(7), (9), (10), (12)
Quick Stop	0	○	0	1	○	(7), (10), (11)
Disable Operation	0	0	1	1	1	(5)
Enable Operation	0	1	1	1	1	(4), (16)
Fault Reset	0 to 1	○	○	○	○	(15)

Note. 0: OFF 1: ON ○: ON/OFF

In faulty communication, hold the state of Bit 7 = 1 for as follows for the Fault Reset command to prevent the command from failing to be recognized.

10 ms ≥ twice the communication cycle: Hold the state for 10 ms.

10 ms < twice the communication cycle: Hold the state for the time determined by doubling the communication cycle.

20. PROFINET COMMUNICATION

Figure 5.1 and Table 5.1 show the FSA state transition conditions. The transition from the Switch on disabled state to the Operation enabled state requires Shutdown, Switch on, and Enable operation to be issued in this order. However, with the _ driver, transition to the target state skipping the states in between is possible.

Current status	Command	Status after transition
Switch on disabled	Switch on	Switched on
Switch on disabled	Enable operation	Operation
Ready to switch on	Enable operation	Operation

20.5.3 Controlword/Statusword

The format of Controlword/Statusword used for the ProcessData communication is different depending on Telegrams you use.

Refer to the following table.

Telegram	ProcessData communication	
	Controlword	Statusword
Standard Telegram 1	Control word 1 (compliant with PROFIdrive)	Status word 1 (compliant with PROFIdrive)
Telegram 100, 102	Controlword (compliant with CiA 402)	Statusword (compliant with CiA 402)

20.5.3.1 Controlword

The drive state can be switched and control commands for the functions of the drive can be issued by rewriting Controlword from the master upper side. Refer to the followings for functions assigned to each bit.

(1) Control word 1 (compliant with PROFIdrive) bit definition

Control word 1 cannot be accessed from the Acyclic communication.

Bit	Name	Description	Controlword (P24640)	
			Bit	Name
0	ON	Refer to section 5.1. (Note 1)	0	Switch On
1	Coast Stop	Refer to section 5.1. (Note 1)	1	Enable Voltage
2	Quick Stop	Refer to section 5.1. (Note 1)	2	Quick Stop
3	Enable Operation	Refer to section 5.1. (Note 1)	3	Enable Operation
4	Depends on the control mode (Refer to each control mode.)			
5				
6				
7	Fault Acknowledge	When 1 is set from 0, alarms are reset. (Note 1)	7	Fault Reset
8	JOG1 (not supported)	Not supported (Note 2)		
9	JOG2 (not supported)	Not supported (Note 2)		
10	Control By PLC	0: Not following PLC command (holding previous value) 1: Drive following PLC command		
11	Depends on the control mode (Refer to each control mode.)			
12		(Note 2)		
13				
14				
15				

Note 1. Bit 0 to 3 and 7 are used for switching drive state. Refer to chapter 5.

Note 2. The values in bit 8, 9, and 12 to 15 at reading are undefined. Set "0" when writing.

20. PROFINET COMMUNICATION

Controlword (compliant with CiA 402) bit definition

Bit	Symbol	Description
0	SO	Switch on (Note 1)
1	EV	Enable voltage (Note 1)
2	QS	Quick stop (Note 1)
3	EO	Enable operation
4	OMS	Differs depending on Modes of operation (P24672). (Refer to each control mode.)
5		
6		
7	FR	Fault reset (Note 1)
8	HALT	0: Operation ready 1: Temporary stop
9	OMS	Differs depending on Modes of operation (P24672). (Refer to each control mode.)
10		(Note 2)
11		
12		
13		
14		
15		

- Note 1. Bit 0 to 3 and 7 are used for switching drive state.
 2. The values in bit 10 to 15 at reading are undefined. Set "0" when writing.

(2) Bit definition of control DI1

Bit	Symbol	Description
0		(Note)
1		
2		
3		
4	C_CDP	Gain switching Turn on C_CDP to use the values of [Pr. PB29] to [Pr. PB36] and [Pr. PB56] to [Pr. PB60] as the load to motor inertia ratio and gain values.
5		(Note)
6		
7		
8		
9		
10		
11		
12		
13		
14		
15		

- Note. The values in bit 0 to 3 and 5 to 15 at reading are undefined. Set "0" when writing.

20. PROFINET COMMUNICATION

(3) Bit definition of control DI2

Bit	Symbol	Description
0		(Note)
1		
2		
3		
4		
5		
6		
7		
8	C_PC	<p>Proportional control</p> <p>Turn C_PC on to switch the speed amplifier from the proportional integral type to the proportional type. If the servo motor at a stop is rotated even one pulse due to any external factor, it generates torque to compensate for a position shift. When the servo motor shaft is to be locked mechanically after positioning completion (stop), switching on the C_PC upon positioning completion will suppress the unnecessary torque generated to compensate for a position shift.</p> <p>When the shaft is to be locked for a long time, use the C_PC and torque limit at the same time to make the torque less than the rated torque.</p>
9		(Note)
10		
11		
12		
13		
14		
15	C_ORST	<p>Operation alarm reset</p> <p>Turn on C_ORST from off to reset [AL. F4 Positioning warning].</p>

Note. The values in bit 0 to 7 and 9 to 14 at reading are undefined. Set "0" when writing.

(4) Bit definition of control DI3

Bit	Symbol	Description
0		(Note)
1		
2		
3		
4		
5		
6		
7		
8		
9		
10		
11		
12		
13		
14		
15		

Note. The values in bit 0 to 15 at reading are undefined. Set "0" when writing.

20. PROFINET COMMUNICATION

20.5.3.2 Statusword

Statusword notifies the master upper side of the drive state of the driver and other drive status. Refer to the followings for functions assigned to each bit.

(1) Status word 1 (compliant with PROFIdrive) bit definition

Bit	Name	Description	Statusword (P24641)	
			Bit	Name
0	Ready To Switch On	Refer to the following table for the definition.	0	Ready To Switch On
1	Ready To Operate	Refer to the following table for the definition.	1	Switched On
2	Operation Enabled	Refer to the following table for the definition.	2	Operation Enabled
3	Fault Present	0: No alarm 1: At alarm occurrence	3	Fault
4	Coast Stop Not Activated	0: During a coasting 1: Other than coasting	4	Voltage Enabled
5	Quick Stop Not Activated	0: During a quick stop 1: other than quick stop (including during the test mode)	5	Quick Stop
6	Switching On Inhibited	Refer to the following table for the definition.	6	Switch On Disabled
7	Warning Present	0: No warning has been occurred. 1: A warning is occurring.	7	Warning
8	Differs depending on Telegrams. (Refer to each control mode.)			
9	Control Requested	0: Not controlled by upper side 1: Controlled by upper side	9	Remote
10	Differs depending on Telegrams. (Refer to each control mode.)			
11				
12				
13				
14				
15				

Bit 0 to 2 and 6 are switched depending on the internal state of driver. The following table shows the details.

Status word 1 (bin)	PROFIdrive state
xxxx xxxx x1xx x000	Switching on inhibited
xxxx xxxx x0xx x001	Ready for switching on
xxxx xxxx x0xx x011	Switched on
xxxx xxxx x0xx x111	Operation
xxxx xxxx x0xx x011	Switching off (Ramp stop, Quick stop)

20. PROFINET COMMUNICATION

(2) Statusword (compliant with CiA 402) bit definition

Bit	Symbol	Description
0	RTSO	Ready-to-switch-on
1	SO	Switch-on
2	OE	Operation-enabled
3	F	Fault
4	VE	Voltage-enabled 0: The bus voltage is lower than the certain (RA) level. 1: The bus voltage is equal to or higher than the certain level.
5	QS	Quick stop 0: During a quick stop 1: No during a quick stop (including during the test mode)
6	SOD	Switch on disabled
7	W	Warning 0: No warning has been occurred. 1: A warning is occurring.
8		(Note)
9	RM	Remote 0: Not following the Controlword command 1: In operation following the Controlword command
10	TR	Target reached Differs depending on Modes of operation (P24672). (Refer to chapter 6.)
11	ILA	Internal limit active 0: The forward rotation stroke end, reverse rotation stroke end, and software position limit have not been reached 1: The forward rotation stroke end, reverse rotation stroke end, or software position limit has been reached. (Enabled in the pp, pv, hm, pt, jg, or idx mode)
12	OMS	Differs depending on Modes of operation (P24672). (Refer to chapter 6.)
13		
14		
15		(Note)

Note. The values in bit 8, 14, and 15 at reading are undefined.

Bit 0 to Bit 3, Bit 5, and Bit 6 are switched depending on the internal state of the driver. Refer to the following table for details.

Statusword (bin)	CiA 402 Drive Profile state
x0xx xxx0 x0xx 0000	Not ready to switch on (Note)
x0xx xxx0 x1xx 0000	Switch on disabled
x0xx xxx0 x01x 0001	Ready to switch on
x0xx xxx0 x01x 0011	Switched on
x0xx xxx0 x01x 0111	Operation enabled
x0xx xxx0 x00x 0111	Quick stop active
x0xx xxx0 x0xx 1111	Fault reaction active
x0xx xxx0 x0xx 1000	Fault

Note. Statusword is not sent in the Not ready to switch on state.

(3) Bit definition of Status DO 1

Bit	Symbol	Description
0	/	(Note)
1		
2	S_SA	Speed reached SA will turn off during servo-off. When the servo motor speed reaches the following range, S_SA turns on. Set speed $\pm ((\text{Set speed} \times 0.05) + 20)$ r/min When the preset speed is 20 r/min or less, SA always turns on.
3	S_MBR	Electromagnetic brake interlock 0: Servo-off or at alarm occurrence
4	S_CDPS	Variable gain selection 1: ON during gain switching
5	S_CLD	During fully closed loop control switching S_CLD turns on during fully closed loop control.
6	/	(Note)
7		
8		
9		
10		
11		
12	S_INP	In-position When the number of droop pulses is in the in-position range, S_INP will turn on. The in-position range can be changed with [Pr. PA10]. When the in-position range is increased, INP may be always on during low-speed rotation. The Status DO cannot be used in the velocity mode or torque mode.
13	S_TLC	Limiting torque When the torque reaches the torque limit value during torque generation, S_TLC will turn on. This will be turned off at servo-off. The Status DO cannot be used in the torque mode.
14	S_ABSV	Absolute position undetermined 1: Absolute position is erased
15	S_BWNG	Battery warning When [AL. 92 battery cable disconnection warning] or [AL. 9F Battery warning] has occurred, S_BWNG turns on. When the battery warning is not occurring, turning on the power will turn off S_BWNG after 2.5 s to 3.5 s.

Note. The values in bit 0, 1, and 6 to 11 at reading are undefined.

(4) Bit definition of Status DO 2

Bit	Symbol	Description
0	S_ZPAS	Z-phase already passed 0: Z-phase unpassed after start-up 1: Z-phase passed once or more after start-up
1		(Note)
2		
3	S_ZSP	Zero speed detection S_ZSP turns on when the servo motor speed is at zero speed or less. Zero speed can be changed with [Pr. PC07].
4	S_VLC	Limiting speed When the speed reaches the speed limit value in the torque mode, S_VLC will turn on. When the servo is off, TLC will be turned off. The Status DO cannot be used in the position mode or velocity mode.
5		(Note)
6		
6	S_IPF	During IPF S_IPF turns on during an instantaneous power failure.
7		(Note)
8		
8	S_PC	Under proportional control S_PC turns on under proportional control.
9		(Note)
10		
10	S_DB	External dynamic brake output When the dynamic brake needs to operate, S_DB turns off.
11		(Note)
12		
13		
14		
15	S_ZP2	Home position return completion 2 (incremental system) When a home position return completes normally, S_ZP2 turns on. S_ZP2 is always on unless the home position is erased. It will be off with the following conditions. 1) [AL. 69 Command error] occurs. 2) Home position return is not being executed. 3) Home position return is in progress.
		Home position return completion 2 (absolute position detection system) If a home position return completes once, S_ZP2 is always on. However, it will be off with the following conditions. 1) [AL. 69 Command error] occurs. 2) Home position return is not being executed. 3) Home position return is in progress. 4) The home position return is not performed after [AL. 25 Absolute position erased] or [AL. E3 Absolute position counter warning] occurred. 5) The home position return is not performed after the electronic gear ([Pr. PA06] or [Pr. PA07]) was changed. 6) The home position return is not performed after the setting of [Pr. PA03 Absolute position detection system selection] was changed from "Disabled" to "Enabled". 7) [Pr. PA14 Rotation direction selection] was changed. 8) [Pr. PA01 Operation mode] was changed.

Note. The values in bit 1, 2, 5, 7, 9, and 11 to 14 at reading are undefined.

20. PROFINET COMMUNICATION

(5) Bit definition of Status DO 3

Bit	Symbol	Description
0	/	(Note)
1		
2		
3		
4		
5	S_STO	During STO S_STO turns on during STO.
6	/	(Note)
7		
8		
9		
10		
11	S_MTTR	Transition to tough drive mode in process When a tough drive is "Enabled" in [Pr. PA20], activating the instantaneous power failure tough drive will turn on S_MTTR.
12	/	(Note)
13		
14		
15		

Note. The values in bit 0 to 4, 6 to 10, and 12 to 15 at reading are undefined.

(6) Bit definition of Status DO 5

Bit	Symbol	Description
0	/	(Note)
1		
2		
3		
4		
5	S_CPO	Rough match When a command remaining distance is lower than the rough match output range set with [Pr. PT12], S_CPO turns on.
6	S_MEND	Travel completion When the droop pulses are within the in-position output range set with [Pr. PA10] and the command remaining distance is "0", S_MEND turns on. S_MEND turns on with servo-on. S_MEND is off at servo-off status. However, S_MEND will not be off in the indexer method.
7	/	(Note)
8		
9		
10		
11		
12		
13		
14		
15		

Note. The values in bit 0 to 4 and 7 to 15 at reading are undefined.

20. PROFINET COMMUNICATION

(7) Bit definition of Status DO 7

Bit	Symbol	Description
0		(Note)
1		
2	S_POT	Position range When an actual current position is within the range set with [Pr. PT19] to [Pr. PT22], S_POT turns on. This will be off when a home position return is not completed or base circuit shut-off is in progress.
3		(Note)
4		
5		
6		
7		
8		
9		
10		
11		
12		
13		
14		
15		

Note. The values in bit 0, 1, and 3 to 15 at reading are undefined.

20. PROFINET COMMUNICATION

20.6 CONTROL MODE

20.6.1 Selection of control mode

Specify a control mode with the combinations of the following conditions.

- [Pr. PA01] (P8193)
- Telegram setting from upper side
- Modes of operation area in Telegram (only Telegram 102)

When the Telegram setting is other than the following combinations, [AL. 37] will occur.

Pr. PA01	Telegram Setting	Modes of operation	Control mode	Remark
___0 ___2	1		Profile velocity mode (pv)	
___0 ___2	100		Profile torque mode (tq)	
___0 ___2	102	0	No mode change/No mode assigned (Note 1)	
		1	Profile position mode (pp)	
		3	Profile velocity mode (pv)	
		4	Profile torque mode (tq)	
		6	Homing mode (hm)	
___1 ___6				Not supported ([AL. 37] occurs.)
___6	103	0	No mode change/No mode assigned (Note 2)	
		6	Homing mode (hm)	
		-100	Jog mode (jg)	
		-101	Point table mode (pt)	
___8	103	0	No mode change/No mode assigned (Note 3)	
		6	Homing mode (hm)	
		-100	Jog mode (jg)	
		-103	Indexer mode (idx)	

Note 1	The control mode at power on will be Profile position mode.
2	The control mode at power on will be Point table mode.
3	The control mode at power on will be Indexer mode.

The following table shows the objects related to control modes.

PNU	Sub	Access	Name	Data Type	Default	Description
24672	0	R/W	Modes of operation	Integer8	Differs depending on [Pr. PA01].	Refer to section 9.3.6.
24673	0	R	Modes of operation display	Integer8	Differs depending on [Pr. PA01].	Refer to section 9.3.6.
25858	0	R	Supported drive mode	Unsigned32	Varies depending on the software version.	Refer to section 9.3.6.

20. 6. 2 Control switching

When telegram 102 is used

Because control switching has a delay, the upper side must keep sending command values corresponding to the control mode before and after the switching. After the completion of control switching has been checked with Modes of operation display, update of the command value before the switching can be stopped.

Before switching the mode from or to Profile position mode (pp), check that the servo motor speed is zero speed. Zero speed state can be obtained with Bit 3 (S_ZSP) of Status DO 2 (P11538). If the motor is not zero speed state, the control will not be switched and Modes of operation display will not change.

Changes to the OMS bit of Controlword are not accepted until control switching is completed. Before inputting commands, check that the control mode has been switched referring to Modes of operation display.

20. 6. 3 Profile position mode (pp)

The following shows the functions and related PROFIdrive parameters of the profile position mode (pp).

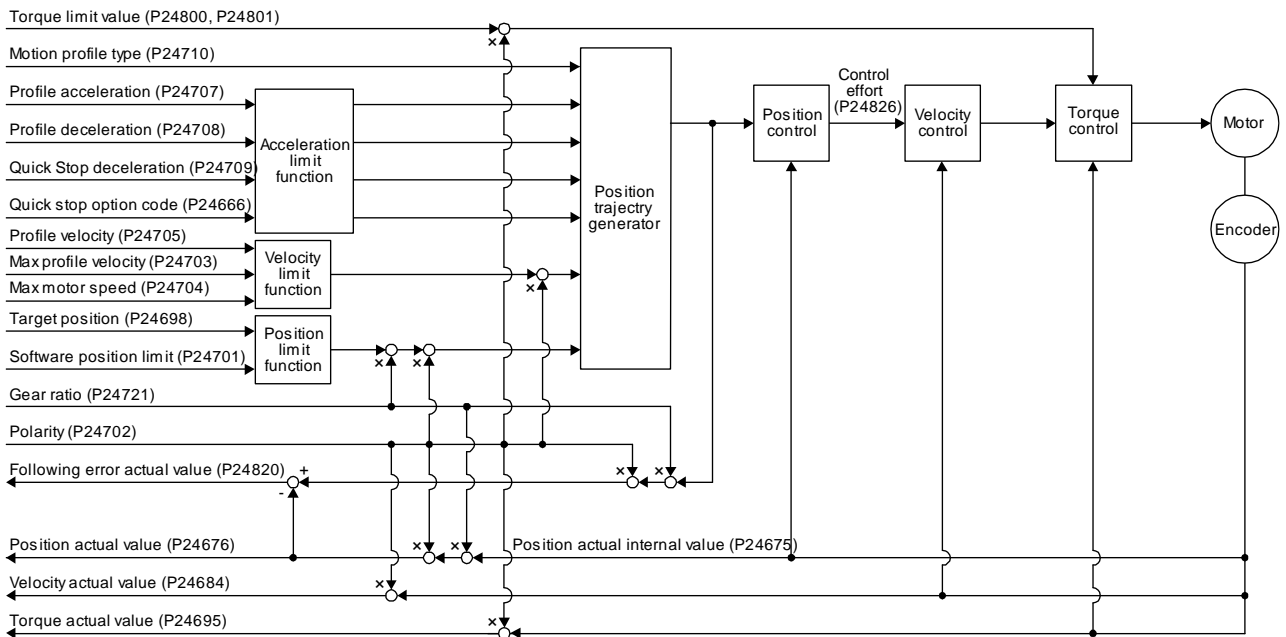

20. PROFINET COMMUNICATION

(1) Related object

PNU	Sub	Access	Name	Type	Default value	Description
24698	0	R/W	Target position	Integer32		Command position (Pos units)
24699	0	R/W	Min position range limit	Array [2] Integer32		Minimum value of the position range limit The value is automatically set according to the setting of "Position data unit" of [Pr. PT01]. mm/inch/pulse: -2147483648 degree: 0
	1	R/W	Max position range limit			Maximum value of the position range limit The value is automatically set according to the setting of "Position data unit" of [Pr. PT01]. mm/inch/pulse: 2147483647 degree: 359999
24701	0	R/W	Min position limit	Array [2] Integer32	0	Minimum position address (Pos units)
	1	R/W	Max position limit		0	Maximum position address (Pos units)
24703	0	R/W	Max profile velocity	Unsigned32	2000000	maximum speed Unit: Vel units (0.01 r/min)
24704	0	R/W	Max motor speed	Unsigned32		Servo motor maximum speed Unit: r/min
24705	0	R/W	Profile velocity	Unsigned32	10000	Speed after acceleration completed Unit: Vel units (0.01 r/min)
24707	0	R/W	Profile acceleration	Unsigned32	0	Acceleration at start of movement to target position Unit: ms
24708	0	R/W	Profile deceleration	Unsigned32	0	Deceleration at arrival at target position Unit: ms
24709	0	R/W	Quick stop deceleration	Unsigned32	100	Deceleration at deceleration to a stop by Quick stop Unit: ms
24710	0	R/W	Motion profile type	Integer16	-1	Acceleration/deceleration type selection -1: S-pattern 0: Linear ramp (not compatible) (Note) 1: Sin ² ramp (not compatible) (Note) 2: Jerk-free ramp (not compatible) (Note) 3: Jerk-limited ramp (not compatible) (Note)
24666	0	R/W	Quick stop option code	Integer16	2	Operation setting for Quick stop Refer to section 8.10.
24675	0	R	Position actual internal value	Integer32		Current position (Enc inc)
24676	0	R	Position actual value	Integer32		Current position (Pos units)
24684	0	R	Velocity actual value	Integer32		Current speed Unit: Vel units (0.01 r/min)
24695	0	R	Torque actual value	Integer16		Current torque Unit: 0.1% (rated torque of 100%)
24722	0	R/W	Feed	Array [2] Unsigned32		Travel distance per revolution of an output shaft Encoder resolution of the connected servo motor at initial value
	1	R/W	Shaft revolutions		1	Number of servo motor shaft revolutions
24820	0	R	Following error actual value	Integer32		Droop pulses (Pos units)
24826	0	R	Control effort	Integer32		Position control loop output (speed command) Unit: Vel units (0.01 r/min)
24800	0	R/W	Positive torque limit value	UInteger16	10000	Torque limit value (forward) Unit: 0.1% (rated torque of 100%)

20. PROFINET COMMUNICATION

PNU	Sub	Access	Name	Type	Default value	Description
24801	0	R/W	Negative torque limit value	UInteger16	10000	Torque limit value (reverse) Unit: 0.1% (rated torque of 100%)
24721	0	R/W	Motor revolutions	Array [2] Unsigned32	1	Gear ratio: Number of revolutions of the servo motor axis (numerator)
	1	R/W	Shaft revolutions		1	Gear ratio: Number of revolutions of the drive axis (denominator)
24702	0	R/W	Polarity	Unsigned8	0	Polarity selection Bit 7: Position POL Bit 6: Velocity POL Bit 5: Torque POL The values other than bit 5, 6, and 7 at reading are undefined. Set "0" when writing. Refer to section 8.5.
24744	0	R/W	SI unit position	Unsigned32	0	SI unit position The value will be set automatically depending on the value of [Pr. PT01] (_ x _ _) and [Pr. PT03] (_ _ _ x). Refer to section 9.3.13 (5) for details.
24745	0	R/W	SI unit velocity	Unsigned32	0	SI unit velocity 0.01 mm/s or 0.01 r/min FB010300h (0.01 mm/s) FEB44700h (0.01 r/min)

Note. This is not supported by the _ driver.

(2) Details on the OMS bit of Controlword (pp mode)

Bit	Symbol	Description
4	New set-point	New positioning parameters are obtained when this bit turns on.
5	Change set immediately	0: Set of set-points 1: Single set-point
6	abs/rel	0: Absolute position command 1: Relative position command (Note)
8	HALT	0: Positioning is executed. 1: The servo motor stops according to Halt option code (P24669).
9	Change on set-point	Enabled only for Set of set-points (Bit 5 = 0). 0: The next positioning starts after the current positioning is completed (stopped) (black line (Refer to (6) in this section.)). 1: The next positioning starts after positioning is executed with Profile velocity held up to the current set-point (gray line (Refer to (6) in this section.)).

Note. When the unit is set to degree, relative position commands are disabled. When the relative position command is specified and positioning is started, [AL. F4.8] occurs and positioning cannot be started.

(3) Details on the OMS bit of Statusword (pp mode)

Bit	Symbol	Description
10	Target reached	0 (Halt (Bit 8) = 0): Target position not reached. 0 (Halt (Bit 8) = 1): Axis decelerates 1 (Halt (Bit 8) = 0): Target position reached. 1 (Halt (Bit 8) = 1): Velocity of axis is 0 Judgment condition for Target position reached If the error between Position actual value and Target position has stayed within Position window for Position window time or more, Target position reached is stored.
12	Set-point acknowledge	0: Positioning completed (wait for next command) 1: Positioning being executed (The set-point can be overwritten.)
13	Following error	0: No following error 1: Following error When the time set with Following error time out (P24678) has elapsed with the number of droop pulses exceeding the set value of the Following error window (P24677), this bit becomes "1".

20. PROFINET COMMUNICATION

(4) Feed constant (P24722)

The following shows setting values of P24722.0 Feed and P24722.1 Shaft revolutions.

[Pr. PT01] setting	Feed	Shaft revolutions	[Pr. PT03] setting
_ 0 _ _ : mm	Encoder resolution of the servo motor	1	___ 0
		10	___ 1
		100	___ 2
		1000	___ 3
_ 2 _ _ : degree	360000	1	___ 0 to ___ 3
_ 3 _ _ : pulse	Encoder resolution of the servo motor	1	___ 0 to ___ 3

No value can be written to Feed because it is set automatically. Writing a value will be Error No. 02h (Low or high limit exceeded).

When the command unit is mm or inch, you can change the travel distance per revolution of an output shaft by changing Shaft revolutions.

The Shaft revolutions setting depends on the setting of "Feed length multiplication [STM]" in [Pr. PT03]. When a value other than the values shown in the table above is set for Shaft revolutions, Error No. 02h (Low or high limit exceeded) will occur.

When the command unit is degree and pulse, the value of Shaft revolutions will be set automatically as the table shows. Writing a value will trigger Error No. 02h (Low or high limit exceeded).

Additionally, Position actual value (P24676) is calculated from Gear ratio (P24721) and Feed constant (P24722) as follows.

$$\text{Position actual value (P24676)} = \frac{\text{Position actual internal value (P24675)} \times \text{Feed constant (P24722)}}{\text{Position encoder resolution (P24719)} \times \text{Gear ratio (P24721)}}$$

When the unit is degree, the operation result will be limited within 0 to 359999.

(5) Single Set-point

Update of positioning parameters during a positioning operation is immediately accepted. (The next positioning starts after the current positioning is canceled.)

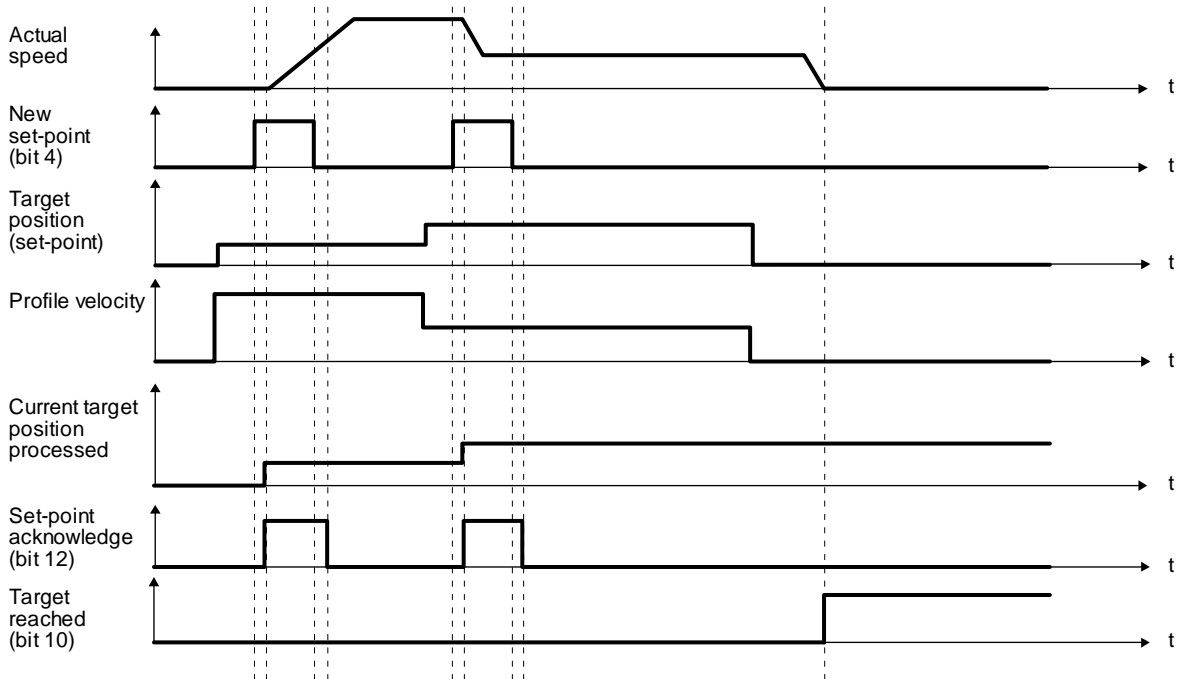

(6) Set of set-points

After the current positioning operation is completed, the next positioning is started. Whether positioning is stopped at the first positioning point when at an update of the positioning parameter before completion of the positioning can be switched. To switch the setting, use Change on set-point (Bit 9 of Controlword).

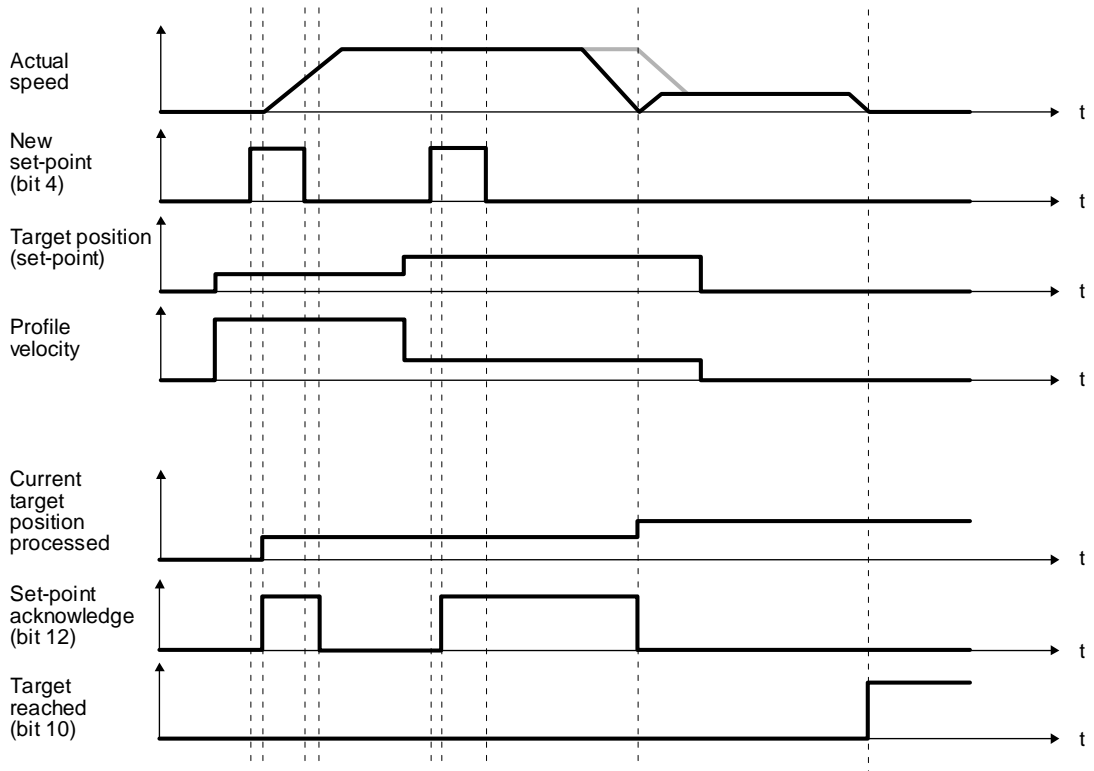

20. PROFINET COMMUNICATION

20.6.4 Profile velocity mode (pv)

The following shows the functions and related PROFIdrive parameters of the profile velocity mode (pv).

The dotted line area in the following diagram is used only for Standard Telegram 1.

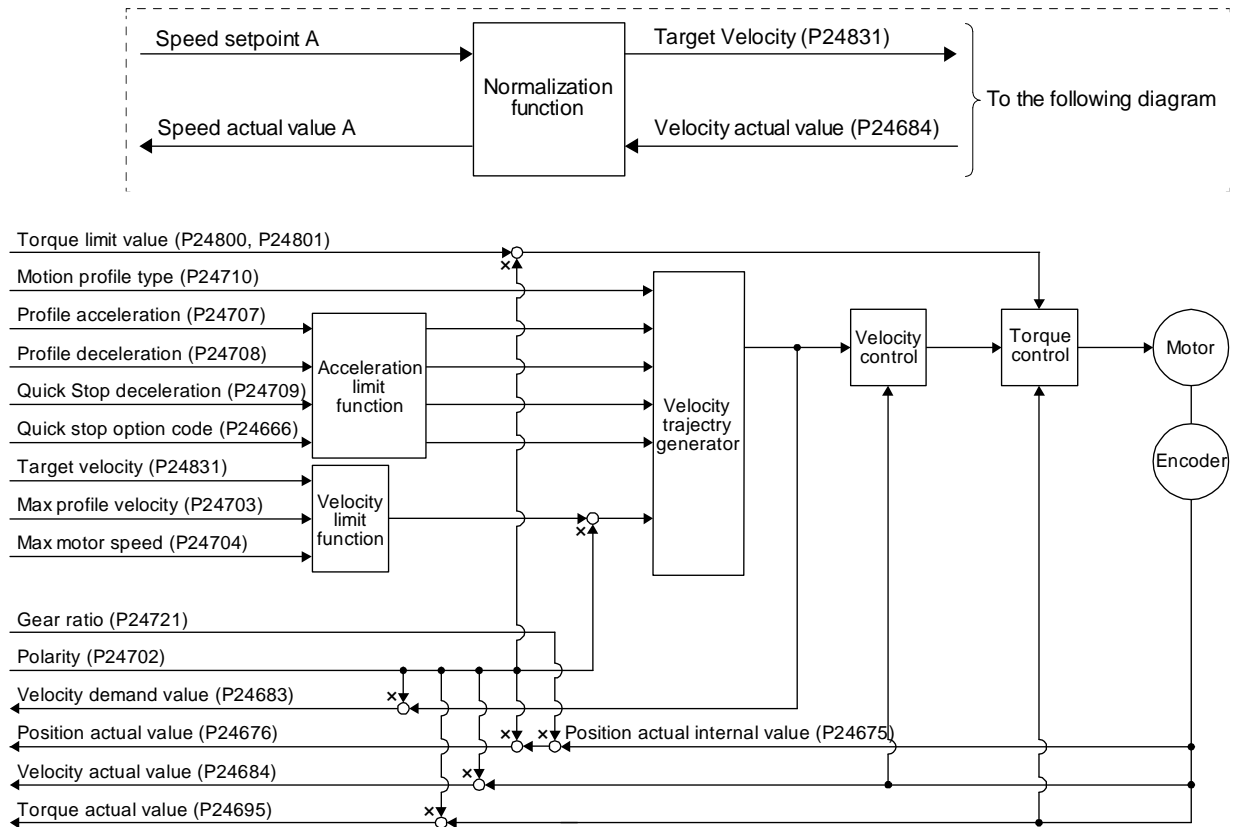

(1) Related object

PNU	Sub	Access	Name	Type	Default value	Description
24831	0	R/W	Target velocity	Integer32		Command speed (Vel units)
24703	0	R/W	Max profile velocity	Unsigned32	2000000	maximum speed Unit: Vel units (0.01 r/min)
24704	0	R/W	Max motor speed	Unsigned32		Servo motor maximum speed Unit: r/min
24707	0	R/W	Profile acceleration	Unsigned32	0	Acceleration at start of movement to target position Unit: ms
24708	0	R/W	Profile deceleration	Unsigned32	0	Deceleration at arrival at target position Unit: ms
24709	0	R/W	Quick stop deceleration	Unsigned32	100	Deceleration at deceleration to a stop by Quick stop Unit: ms
24710	0	R/W	Motion profile type	Integer16	-1	Acceleration/deceleration type selection -1: S-pattern 0: Linear ramp (Not compatible) (Note) 1: Sin ² ramp (Not compatible) (Note) 2: Jerk-free ramp (not compatible) (Note) 3: Jerk-limited ramp (not compatible) (Note)
24666	0	R/W	Quick stop option code	Integer16	2	Operation setting for Quick stop Refer to section 8.10.

20. PROFINET COMMUNICATION

PNU	Sub	Access	Name	Type	Default value	Description
24675	0	R	Position actual internal value	Integer32		Current position (Enc inc)
24676	0	R	Position actual value	Integer32		Current position (Pos units)
24683	0	R	Velocity demand value	Integer32		Speed command (after trajectory generation)
24684	0	R	Velocity actual value	Integer32		Current speed Unit: Vel units (0.01 r/min)
24695	0	R	Torque actual value	Integer16		Current torque Unit: 0.1% (rated torque of 100%)
24800	0	R/W	Positive torque limit value	Unsigned16	10000	Torque limit value (forward) Unit: 0.1% (rated torque of 100%)
24801	0	R/W	Negative torque limit value	Unsigned16	10000	Torque limit value (reverse) Unit: 0.1% (rated torque of 100%)
24721	0	R/W	Motor revolutions	Array [2] Unsigned32	1	Gear ratio: Number of revolutions of the servo motor axis (numerator)
	1	R/W	Shaft revolutions		1	Gear ratio: Number of revolutions of the drive axis (denominator)
24722	0	R/W	Feed	Array [2] Unsigned32		Travel distance per revolution of an output shaft Encoder resolution of the servo motor at initial value
	1	R/W	Shaft revolutions		1	Number of servo motor shaft revolutions
24702	0	R/W	Polarity	Unsigned8	0	Polarity selection Bit 7: Position POL Bit 6: Velocity POL Bit 5: Torque POL The values other than bit 5, 6, and 7 at reading are undefined. Set "0" when writing. Refer to section 8.5.
24685	0	R/W	Velocity window	Unsigned16	2000	Speed error threshold for judging Target reached Unit: Vel units (0.01 r/min)
24686	0	R/W	Velocity window time	Unsigned16	10	Target reached judgment time Unit: ms
24687	0	R/W	Velocity threshold	Unsigned16	5000	Zero speed threshold for judging Speed Unit: Vel units (0.01 r/min)
24688	0	R/W	Velocity threshold time	Unsigned16	10	Speed judgment time Unit: ms
24744	0	R/W	SI unit position	Unsigned32	0	SI unit position The value will be set automatically depending on the value of [Pr. PT01] (_ x _) and [Pr. PT03] (_ _ _ x). Refer to section 9.3.13 (5) for details.
24745	0	R/W	SI unit velocity	Unsigned32	0	SI unit velocity 0.01 mm/s or 0.01 r/min FB010300h (0.01 mm/s) FEB44700h (0.01 r/min)

Note. This is not supported by the driver.

20. PROFINET COMMUNICATION

(2) Details on the Control word 1 (compliant with PROFIdrive) bit (pv mode) (only when using Standard telegram 1)

Bit	Name	Description	Controlword (P24640)	
			Bit	Name
4	Enable Ramp Generator	Refer to the following table for the definition.	8	Halt
5	Unfreeze Ramp Generator			
6	Enable Setpoint			
11		(Note)		
12				
13				
14				
15				

Note. The values in bit 11 to 15 at reading are undefined. Set "0" when writing.

Details of bit 4, 5, and 6

Bit 4	Bit 5	Bit 6	Description
0			The servo motor stops according to Halt option code (P24669).
1	0		Command speed is followed up with Velocity demand value (P24683).
1	1	0	Command speed is set to 0.
1	1	1	Command speed is updated.

(3) Details on the OMS bit of Controlword (pv mode)

Bit	Symbol	Description
4	(reserved)	(Note)
5	(reserved)	
6	(reserved)	
8	HALT	0: The servo motor is driven. 1: The servo motor stops according to Halt option code (P24669).
9	(reserved)	(Note)

Note. The values in bit 4 to 6, and 9 at reading are undefined. Set "0" when writing.

20. PROFINET COMMUNICATION

(4) Details on the Status word 1 (compliant with PROFIdrive) bit (pv mode) (only when using Standard telegram 1)

Bit	Name	Description	Statusword (P24641)	
			Bit	Name
8	Speed Error (Not supported)			
10	Speed Reached	Refer to the following table for the definition.	10	Target velocity reached
11	Internal limit active	Internal limit active 0: The forward rotation stroke end, reverse rotation stroke end, and software position limit have not been reached 1: The forward rotation stroke end, reverse rotation stroke end, or software position limit has been reached.	11	Internal limit active
12	Speed	0: Speed is not equal 0 1: Speed is equal 0 Judgment condition for Speed is not equal 0 If the absolute value of Velocity actual value has exceeded Velocity threshold for Velocity threshold time or more, Speed is not equal 0 is stored.	12	Speed
13		(Note)		
14				
15				

Note. The values in bit 8 and 13 to 15 at reading are undefined.

Speed Reached

Status word 1 bit 10	Control word 1 bit 4	Description
Speed Reached (Note)	Enable Ramp Generator	
0	0	Target velocity not reached.
	1	Axis decelerates
1	0	Target velocity reached.
	1	Velocity of axis is 0

Note. Judgment condition for Speed Reached: If the error between Velocity actual value and Target velocity has stayed within Velocity window for Velocity window time or more, Speed Reached is stored.

(5) Details on the OMS bit of Statusword (pv mode)

Bit	Symbol	Description
10	Target reached	0 (Halt (Bit 8) = 0): Target velocity not reached. 0 (Halt (Bit 8) = 1): Axis decelerates 1 (Halt (Bit 8) = 0): Target velocity reached. 1 (Halt (Bit 8) = 1): Velocity of axis is 0 Judgment condition for Target velocity reached If the error between Actual velocity and Target velocity has stayed within Velocity window for Velocity window time or more, Target velocity reached is stored.
12	Speed	0: Speed is not equal 0 1: Speed is equal 0 Judgment condition for Speed is not equal 0 If the absolute value of Actual velocity has exceeded Velocity threshold for Velocity threshold time or more, Speed is not equal 0 is stored.
13	Max slippage error	0: Maximum slippage not reached 1: Maximum slippage reached (not supported) (Note) Max slippage is a maximum slippage of the asynchronous servo motor.

Note. This is not supported by the driver.

20. PROFINET COMMUNICATION

(6) Speed setpoint A (only when using Standard telegram 1)

Speed setpoint A is a target speed.

The _ driver receives Speed setpoint A from the upper side, converts it to a target speed, and set it to Target Velocity (P24831).

$$\text{Speed setpoint A} = \frac{\text{Target Velocity (P24831)}}{100}$$

(7) Speed actual value A (only when using Standard telegram 1)

Speed actual value A is a current speed.

The _ driver converts Velocity actual value (P24684) to Speed actual value A and transmits it to the upper side.

$$\text{Speed actual value A} = \frac{\text{Velocity actual value (P24684)}}{100}$$

(8) Feed constant (P24722)

The following shows setting values of P24722.0 Feed and P24722.1 Shaft revolutions.

[Pr. PT01] setting	Feed	Shaft revolutions	[Pr. PT03] setting
_ 0 _ : mm	Encoder resolution of the servo motor	1	___ 0
		10	___ 1
		100	___ 2
		1000	___ 3
_ 1 _ : inch			
_ 2 _ : degree	360000	1	___ 0 to ___ 3
_ 3 _ : pulse	Encoder resolution of the servo motor	1	___ 0 to ___ 3

No value can be written to Feed because it is set automatically. Writing a value will be Error No. 02h (Low or high limit exceeded).

When the command unit is mm or inch, you can change the travel distance per revolution of an output shaft by changing Shaft revolutions.

The Shaft revolutions setting depends on the setting of "Feed length multiplication [STM]" in [Pr. PT03]. When a value other than the values shown in the table above is set for Shaft revolutions, Error No. 02h (Low or high limit exceeded) will occur.

When the command unit is degree and pulse, the value of Shaft revolutions will be set automatically as the table shows. Writing a value will trigger Error No. 02h (Low or high limit exceeded).

Additionally, Position actual value (P24676) is calculated from Gear ratio (P24721) and Feed constant (P24722) as follows.

$$\text{Position actual value (P24676)} = \frac{\text{Position actual internal value (P24675)} \times \text{Feed constant (P24722)}}{\text{Position encoder resolution (P24719)} \times \text{Gear ratio (P24721)}}$$

When the unit is degree, the operation result will be limited within 0 to 359999.

(9) The pv mode operation sequence

When using Standard telegram 1, replace the following left signals to the right signals.

Signal name	When using Standard telegram 1
Velocity Actual Value	Speed actual value A
Target Velocity	Speed Setpoint A
Target reached (Statusword bit 10)	Speed reached (Status word 1 bit 10)
Speed (Statusword bit 12)	Speed (Status word 1 bit 12)

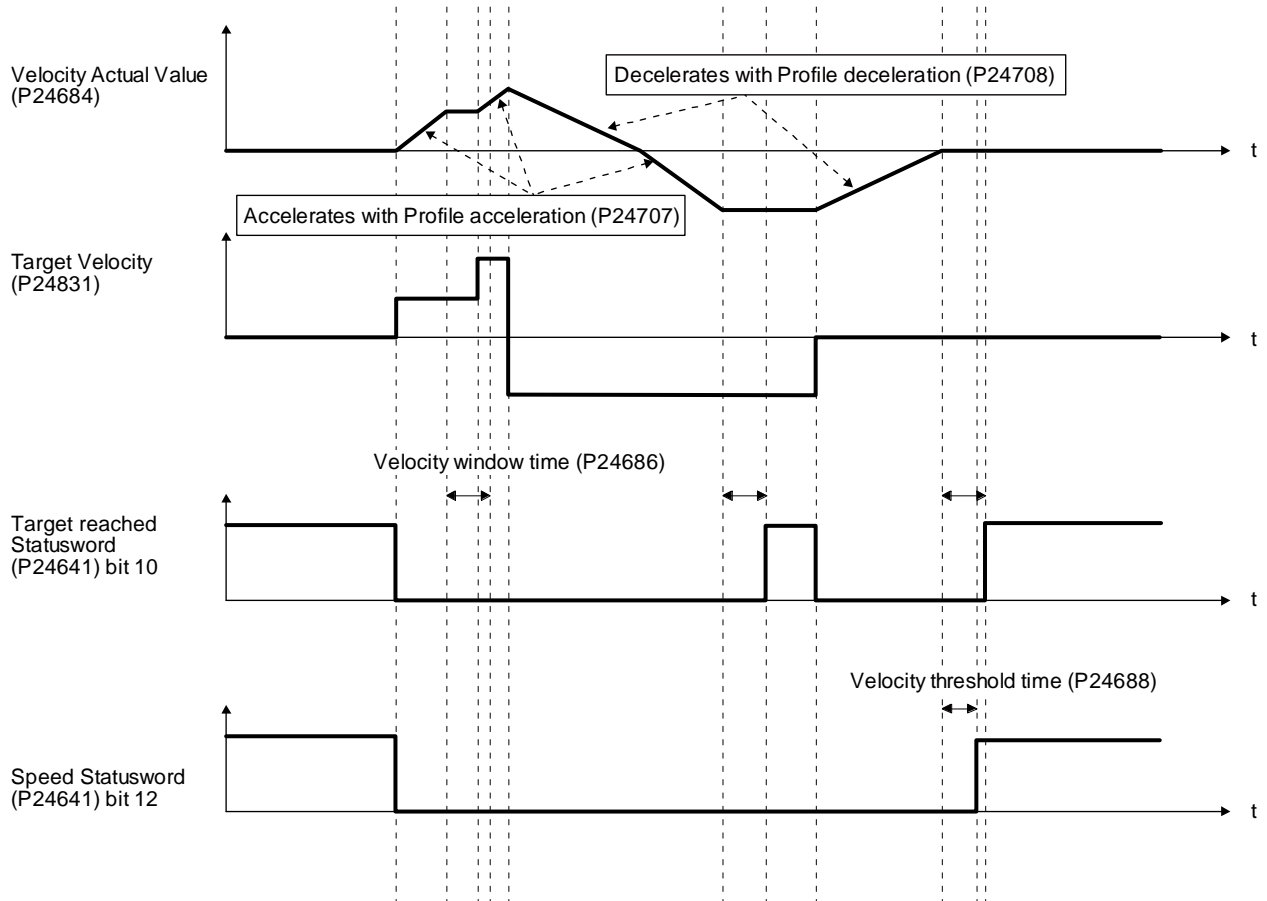

20. PROFINET COMMUNICATION

20.6.5 Profile torque mode (tq)

The following shows the functions and related PROFIdrive parameters of the Profile torque mode (tq).

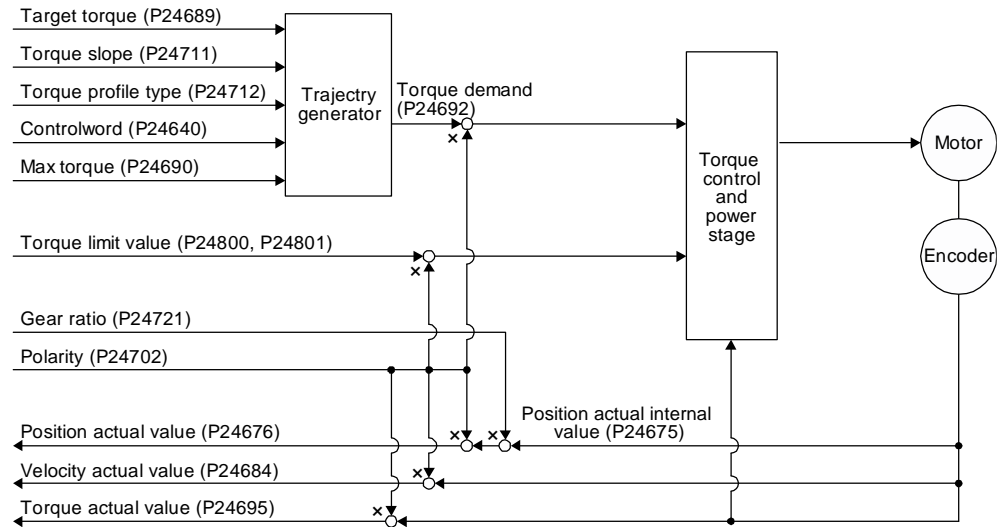

(1) Related object

PNU	Sub	Access	Name	Type	Default value	Description
24689	0	R/W	Target torque	Integer16		Command torque Unit: 0.1% (rated torque of 100%)
24690	0	R/W	Max torque	Unsigned16		Maximum torque Unit: 0.1% (rated torque of 100%)
24692	0	R	Torque demand	Integer16		Command torque (after limit) Unit: 0.1% (rated torque of 100%)
24711	0	R/W	Torque slope	Unsigned32	0	Torque variation Unit: 0.1%/s (rated torque of 100%)
24712	0	R/W	Torque profile type	Unsigned32	0	Torque variation pattern 0000h: Linear ramp 0001h: Sin ² ramp (not supported) (Note) 0002h to 7FFFh: reserved 8000h to FFFFh: Manufacturer specific
24675	0	R	Position actual internal value	Integer32		Current position (Enc inc)
24676	0	R	Position actual value	Integer32		Current position (Pos units)
24684	0	R	Velocity actual value	Integer32		Current speed Unit: Vel units (0.01 r/min)
24695	0	R	Torque actual value	Integer16		Current torque Unit: 0.1% (rated torque of 100%)
24800	0	R/W	Positive torque limit value	Unsigned16	10000	Torque limit value (forward) Unit: 0.1% (rated torque of 100%)
24801	0	R/W	Negative torque limit value	Unsigned16	10000	Torque limit value (reverse) Unit: 0.1% (rated torque of 100%)
24721	0	R/W	Motor revolutions	Array [2] Unsigned32	1	Gear ratio: Number of revolutions of the servo motor axis (numerator)
	1	R/W	Shaft revolutions		1	Gear ratio: Number of revolutions of the drive axis (denominator)
24722	0	R/W	Feed	Array [2] Unsigned32		Travel distance per revolution of an output shaft Encoder resolution of the servo motor at initial value
	1	R/W	Shaft revolutions		1	Number of servo motor shaft revolutions

20. PROFINET COMMUNICATION

PNU	Sub	Access	Name	Type	Default value	Description
24702	0	R/W	Polarity	Unsigned8	0	Polarity selection Bit 7: Position POL Bit 6: Velocity POL Bit 5: Torque POL The values other than bit 5, 6, and 7 at reading are undefined. Set "0" when writing. Refer to section 8.5.
11552	0	R/W	Velocity limit value	Integer32	50000	Speed limit value Unit: Vel units (0.01 r/min)
24744	0	R/W	SI unit position	Unsigned32	0	SI unit position The value will be set automatically depending on the value of [Pr. PT01] (_ x _) and [Pr. PT03] (_ _ _ x). Refer to section 9.3.13 (5) for details.
24745	0	R/W	SI unit velocity	Unsigned32	0	SI unit velocity 0.01 mm/s or 0.01 r/min FB010300h (0.01 mm/s) FEB44700h (0.01 r/min)

Note. This is not supported by the driver.

(2) Details on the OMS bit of Controlword (tq mode)

Bit	Symbol	Description
4	(reserved)	(Note)
5	(reserved)	
6	(reserved)	
8	HALT	0: The servo motor is driven. 1: The servo motor stops according to Halt option code (P24669).
9	(reserved)	(Note)

Note. The values in bit 4 to 6, and 9 at reading are undefined. Set "0" when writing.

(3) Details on the OMS bit of Statusword (tq mode)

Bit	Symbol	Description
10	Target reached (not compatible) (Note 1)	0 (Halt (Bit 8) = 0): Target torque not reached. 0 (Halt (Bit 8) = 1): Axis decelerates 1 (Halt (Bit 8) = 0): Target torque reached. 1 (Halt (Bit 8) = 1): Velocity of axis is 0 Judgment condition for Target torque reached If the error between Torque actual value and Target torque has stayed within Torque window for Torque window time or more, Target torque reached is stored. (Note 2)
12	(reserved)	(Note 2)
13	(reserved)	(Note 2)

Note 1. This is not supported by the driver.

Note 2. The value at reading is undefined.

(4) Feed constant (P24722)

The following shows setting values of P24722.0 Feed and P24722.1 Shaft revolutions.

[Pr. PT01] setting	Feed	Shaft revolutions	[Pr. PT03] setting
_ 0 _ : mm	Encoder resolution of the servo motor	1	___ 0
		10	___ 1
_ 1 _ : inch		100	___ 2
		1000	___ 3
_ 2 _ : degree	360000	1	___ 0 to ___ 3
_ 3 _ : pulse	Encoder resolution of the servo motor	1	___ 0 to ___ 3

No value can be written to Feed because it is set automatically. Writing a value will be Error No. 02h (Low or high limit exceeded).

When the command unit is mm or inch, you can change the travel distance per revolution of an output shaft by changing Shaft revolutions.

The Shaft revolutions setting depends on the setting of "Feed length multiplication [STM]" in [Pr. PT03]. When a value other than the values shown in the table above is set for Shaft revolutions, Error No. 02h (Low or high limit exceeded) will occur.

When the command unit is degree and pulse, the value of Shaft revolutions will be set automatically as the above table shows. Writing a value will be Error No. 02h (Low or high limit exceeded).

Additionally, Position actual value (P24676) is calculated from Gear ratio (P24721) and Feed constant (P24722) as follows.

$$\text{Position actual value (P24676)} = \frac{\text{Position actual internal value (P24675)} \times \text{Feed constant (P24722)}}{\text{Position encoder resolution (P24719)} \times \text{Gear ratio (P24721)}}$$

When the unit is degree, the operation result will be limited within 0 to 359999.

(5) The tq mode operation sequence

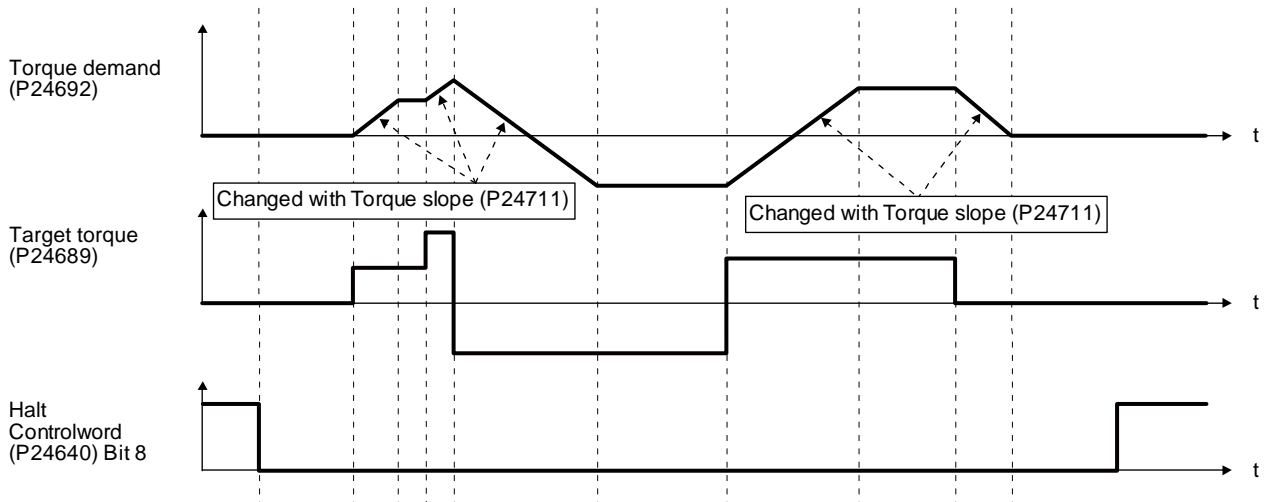

20. PROFINET COMMUNICATION

20.6.6 Homing mode (hm)

The following shows the functions and related PROFIdrive parameters of the homing mode (hm).

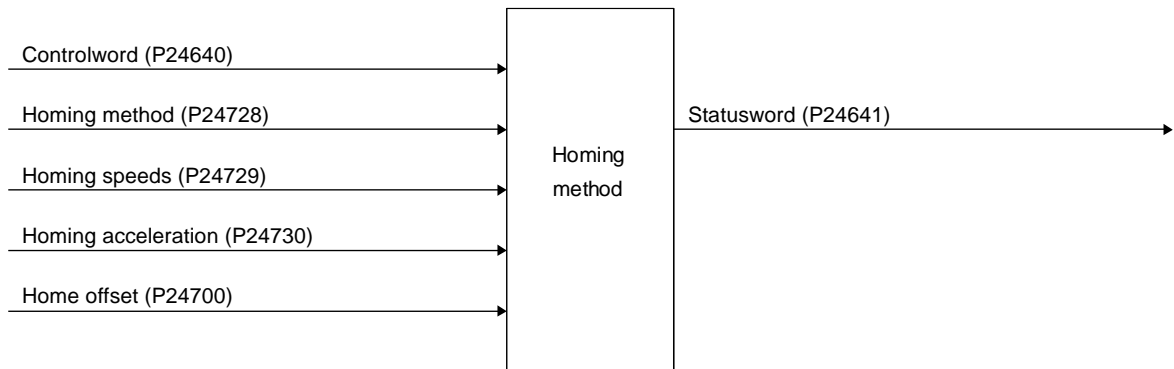

(1) Related object

In the homing mode (hm), the servo motor is not brought to a slow stop according to the deceleration time constant when the stroke end is detected. The motor is brought to a quick stop. Set the home position return speed carefully.

PNU	Sub	Access	Name	Type	Default value	Description
24700	0	R	Home offset	Integer32		The home position saved in EEPROM is stored at power-on. If a home position return is executed in the homing mode (hm), the home position will be updated. If [Pr. PA03 Absolute position detection system] is disabled, 0 is always stored.
24728	0	R/W	Homing Method	Integer8	-1	Specify a home position return type. Refer to (4) in this section for supported home position return types.
24729	0	R/W	Speed during search for switch	Array [2] Unsigned32	10000	Specify the travel speed until dog detection. Unit: Vel units (0.01 r/min) Range: 0 to servo motor maximum speed
	1	R/W	Speed during search for zero		1000	Specify the travel speed up to the home position after dog detection. Unit: Vel units (0.01 r/min) Range: 0 to servo motor maximum speed
24730	0	R/W	Homing acceleration	Unsigned32	0	Acceleration/deceleration time constant at home position return Unit: ms
24803	0	R	1 st supported homing method	Array [39] Integer8	37	The home position return type that uses the current position as a home position is supported.
	to					
	38	R	39 th supported homing method		-43	The dogless Z-phase reference home position return type (reverse rotation) is supported.

20. PROFINET COMMUNICATION

(2) Details on the OMS bit of Controlword (hm mode)

Bit	Symbol	Description
4	HOS	Homing operation start (Note 1) 0: Do not start homing procedure 1: Start or continue homing procedure
5		(Reserved) (Note 2)
6		(Reserved) (Note 2)
8 (Note 3)	HALT	Halt (Note 1) 0: Bit 4 enable 1: Stop axis according to halt option code (P24669)

- Note
1. Bit 4 and 8 are enabled only in the homing mode (hm).
 2. The values in bit 5 and 6 at reading are undefined. Set "0" when writing.
 3. Bit 8 is disabled in the indexer method.

(3) Details on the OMS bit of Statusword (hm mode)

Bit	Symbol	Description
10	Target reached	Refer to the following table for the definition.
12	Homing attained	Refer to the following table for the definition.
13	Homing error	Refer to the following table for the definition.

Statusword Bit 10, 12, and 13 in the hm mode.

Bit 13	Bit 12	Bit 10	Definition
0	0	0	Homing procedure is in progress.
0	0	1	Homing procedure is interrupted or not started.
0	1	0	Homing is attained, but target is not reached.
0	1	1	Homing procedure is completed successfully.
1	0	0	Homing error occurred, velocity is not 0.
1	0	1	Homing error occurred, velocity is 0.
1	1		reserved

(4) List of Homing method

POINT
<ul style="list-style-type: none">● In the following cases, make sure that the Z-phase has been passed through once before the home position return. Z-phase unpassed will trigger [AL. 90.5 Z-phase unpassed].● To execute a home position return securely, start a home position return after moving the servo motor to the opposite stroke end with csv or pv from the upper side and others. Whether the servo motor has reached the stroke end can be checked with Digital inputs (P24829).● When changing the mode after the home position return completion, set 0 to the Target position (P24698) and change the control mode.● The Method numbers which can be used in indexer method are only -1, -33, -3, 35 and 37.

To specify the home position return type in the homing mode (hm), use Homing Method (P24728). The _ driver supports Homing method in the following table.

Method No.	Home position return type	Rotation direction	Description
-1	Dog type (Rear end detection Z-phase reference)/ Torque limit changing dog type (Front end detection Z-phase reference)	Forward rotation	Deceleration starts at the front end of the proximity dog. After the rear end is passed, the position specified by the first Z-phase signal, or the position of the first Z-phase signal shifted by the specified home position shift distance is used as the home position. In the indexer method, deceleration starts at the front end of the proximity dog, and then the first Z-phase signal at which a deceleration to a stop is possible or the position of the Z-phase signal shifted by the specified home position shift distance is used as the home position. The torque limit values in Positive torque limit value (P24800) and Negative torque limit value (P24801) are enabled during execution of home position return, and the torque limit value in Torque limit value2 (P11627) is enabled when the home position return is stopped.
-33		Reverse rotation	
-3	Data set type home position return/ Torque limit changing data set type		The current position is set as the home position. In the indexer method, the current position is set as the home position. The torque limit value becomes "0" when switched to the homing mode.
-4	Stopper type (Stopper position reference)	Forward rotation	A workpiece is pressed against a mechanical stopper, and the position where it is stopped is set as the home position.
-36		Reverse rotation	
-2	Count type (Front end detection Z-phase reference)	Forward rotation	At the front end of the proximity dog, deceleration starts. After the front end is passed, the position specified by the first Z-phase signal after the set distance or the position of the Z-phase signal shifted by the set home position shift distance is set as a home position.
-34		Reverse rotation	
-6	Dog type (Rear end detection rear end reference)	Forward rotation	Deceleration starts from the front end of the proximity dog. After the rear end is passed, the position is shifted by the travel distance after proximity dog and the home position shift distance. The position after the shifts is set as the home position.
-38		Reverse rotation	
-7	Count type (Front end detection front end reference)	Forward rotation	Deceleration starts from the front end of the proximity dog. The position is shifted by the travel distance after proximity dog and the home position shift distance. The position after the shifts is set as the home position.
-39		Reverse rotation	
-8	Dog cradle type	Forward rotation	A position, which is specified by the first Z-phase signal after the front end of the proximity dog is detected, is set as the home position.
-40		Reverse rotation	
-9	Dog type last Z-phase reference	Forward rotation	After the front end of the proximity dog is detected, the position is shifted away from the proximity dog in the reverse direction. Then, the position specified by the first Z-phase signal or the position of the first Z-phase signal shifted by the home position shift distance is used as the home position.
-41		Reverse rotation	
-10	Dog type front end reference	Forward rotation	Starting from the front end of the proximity dog, the position is shifted by the travel distance after proximity dog and the home position shift distance. The position after the shifts is set as the home position.
-42		Reverse rotation	
-11	Dogless Z-phase reference	Forward rotation	The position specified by the first Z-phase signal, or the position of the first Z-phase signal shifted by the home position shift distance is used as the home position.
-43		Reverse rotation	
3	Homing on positive home switch and index pulse	Forward rotation	Same as the dog type last Z-phase reference home position return. Note that if the stroke end is detected during home position return, [AL. 90 Home position return incomplete warning] occurs.
4	Homing on positive home switch and index pulse	Forward rotation	Same as the dog cradle type home position return. Note that if the stroke end is detected during home position return, [AL. 90 Home position return incomplete warning] occurs.

20. PROFINET COMMUNICATION

5	Homing on negative home switch and index pulse	Reverse rotation	Same as the dog type last Z-phase reference home position return. Note that if the stroke end is detected during home position return, [AL. 90 Home position return incomplete warning] occurs.
6	Homing on negative home switch and index pulse	Reverse rotation	Same as the dog cradle type home position return. Note that if the stroke end is detected during home position return, [AL. 90 Home position return incomplete warning] occurs.
7	Homing on home switch and index pulse	Forward rotation	Same as the dog type last Z-phase reference home position return.
8	Homing on home switch and index pulse	Forward rotation	Same as the dog cradle type home position return.
11	Homing on home switch and index pulse	Reverse rotation	Same as the dog type last Z-phase reference home position return.
12	Homing on home switch and index pulse	Reverse rotation	Same as the dog cradle type home position return.
19	Homing without index pulse	Forward rotation	Same as the dog type front end reference home position return. Note that if the stroke end is detected during home position return, [AL. 90 Home position return incomplete warning] occurs.
20	Homing without index pulse	Forward rotation	Although this type is the same as the dog cradle type home position return, the stop position is not on the Z-phase. Starting from the front end of the dog, the position is shifted by the travel distance after proximity dog and the home position shift distance. The position after the shifts is set as the home position. If the stroke end is detected during home position return, [AL. 90 Home position return incomplete warning] occurs.
21	Homing without index pulse	Reverse rotation	Same as the dog type front end reference home position return. Note that if the stroke end is detected during home position return, [AL. 90 Home position return incomplete warning] occurs.
22	Homing without index pulse	Reverse rotation	Although this type is the same as the dog cradle type home position return, the stop position is not on the Z-phase. Starting from the front end of the dog, the position is shifted by the travel distance after proximity dog and the home position shift distance. The position after the shifts is set as the home position. If the stroke end is detected during home position return, [AL. 90 Home position return incomplete warning] occurs.
23	Homing without index pulse	Forward rotation	Same as the dog type front end reference home position return.
24	Homing without index pulse	Forward rotation	Although this type is the same as the dog cradle type home position return, the stop position is not on the Z-phase. Starting from the front end of the dog, the position is shifted by the travel distance after proximity dog and the home position shift distance. The position after the shifts is set as the home position.
27	Homing without index pulse	Reverse rotation	Same as the dog type front end reference home position return.
28	Homing without index pulse	Reverse rotation	Although this type is the same as the dog cradle type home position return, the stop position is not on the Z-phase. Starting from the front end of the dog, the position is shifted by the travel distance after proximity dog and the home position shift distance. The position after the shifts is set as the home position.
33	Homing on index pulse	Reverse rotation	Although this type is the same as the dogless Z-phase reference home position return, the creep speed is applied as the movement start speed.
34	Homing on index pulse	Forward rotation	Although this type is the same as the dogless Z-phase reference home position return, the creep speed is applied as the movement start speed.
35	Homing on current position		The current position is set as the home position. This type can be executed not in the Operation Enabled (servo-on) state.
37	Homing on current position		The current position is set as the home position. This type can be executed not in the Operation Enabled (servo-on) state.

(5) CiA 402-type homing method

(a) Home position return type in CiA 402 type

The following shows the CiA 402-type home position return.

1) Method 3 and 4: Homing on positive home switch and index pulse

These home position return types use the front end of the proximity dog as reference and set the Z-phase right before and right after the dog as a home position.

Method 3 has the operation of the dog type last Z-phase reference home position return, and

Method 4 has the operation of the dog cradle type home position return at a forward rotation start.

However, if the stroke end is detected during home position return, [AL. 90] occurs.

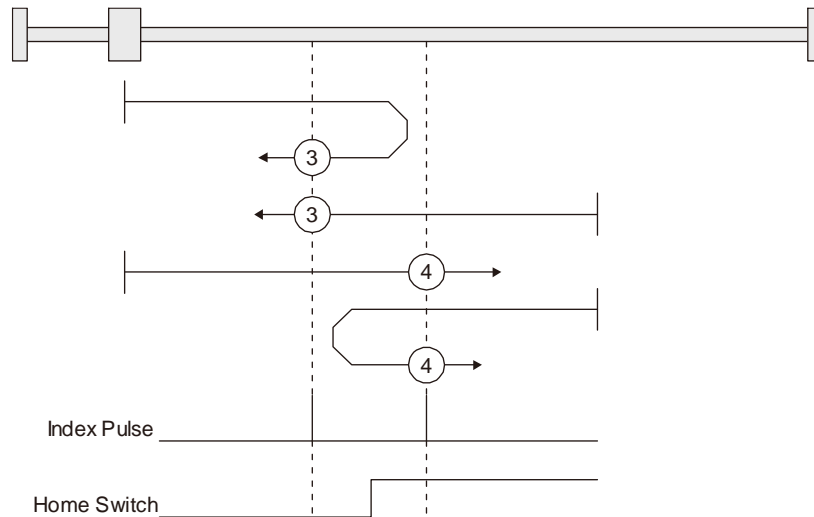

2) Method 5 and 6: Homing on negative home switch and index pulse

These home position return types use the front end of the proximity dog as reference and set the Z-phase right before and right after the dog as a home position. Method 5 and 6 differ from Method 3 and Method 4 in the starting direction: the starting direction of Method 5 and 6 is the reversed direction.

3) Method 7, 8, 11, 12: Homing on home switch and index pulse

These types include the operation at stroke end detection in addition to the operation of Method 3 to Method 6. Thus, the home position is the same as that of Method 3 to Method 6. Method 7 has the operation of the dog type last Z-phase reference home position return. Method 8 has the operation of the dog cradle type home position return at a forward rotation start. Method 11 and 12 differ from Method 7 and Method 8 only in the starting direction: the starting direction of Method 11 and 12 is the reversed direction.

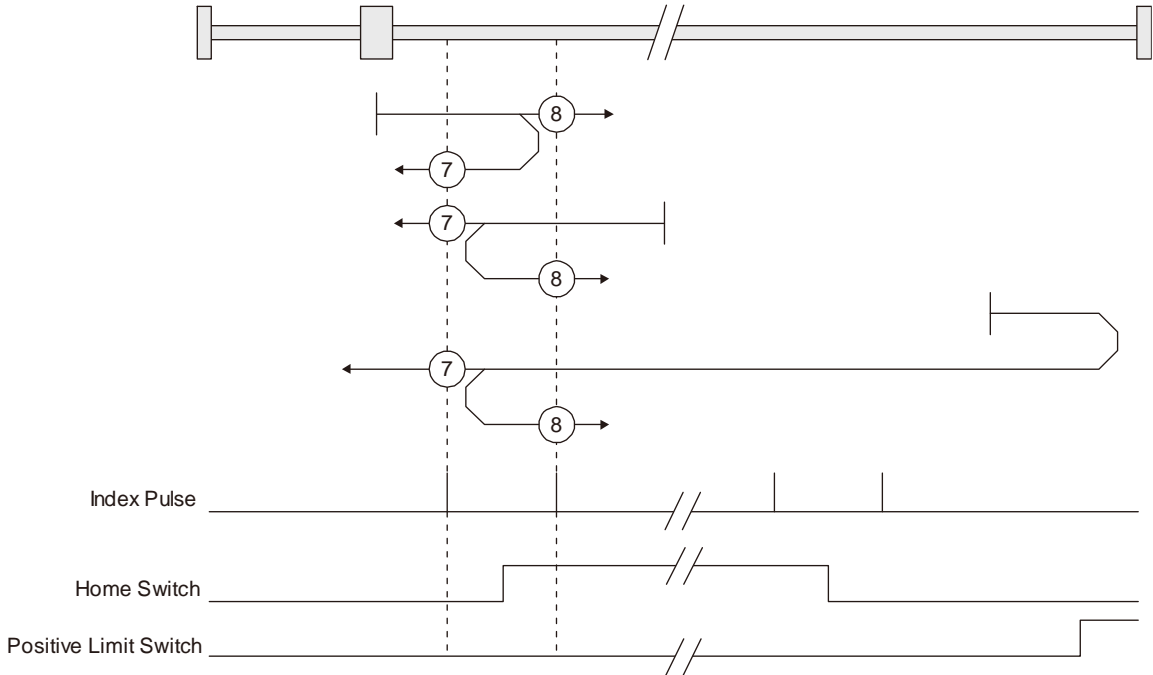

4) Method 17 to 30: Homing without index pulse

Method 17 to 30 have the operation of Method 1 to Method 14; however, these types set the home position not on the Z-phase but on the dog. Method 17 to 30 have the operation of Method 1 to Method 14; however, these types set the home position not on the Z-phase but on the dog. The following figure shows the operation of the home position return type of Method 19 and Method 20. Method 19 and Method 20 have the operation of Method 3 and Method 4; however, these types set the home position not on the Z-phase but on the dog Method 19 has the operation of the dog type front end reference home position return. Method 20 has the operation of the dog cradle type home position return; however, the stop position is not on the Z-phase but on the dog.

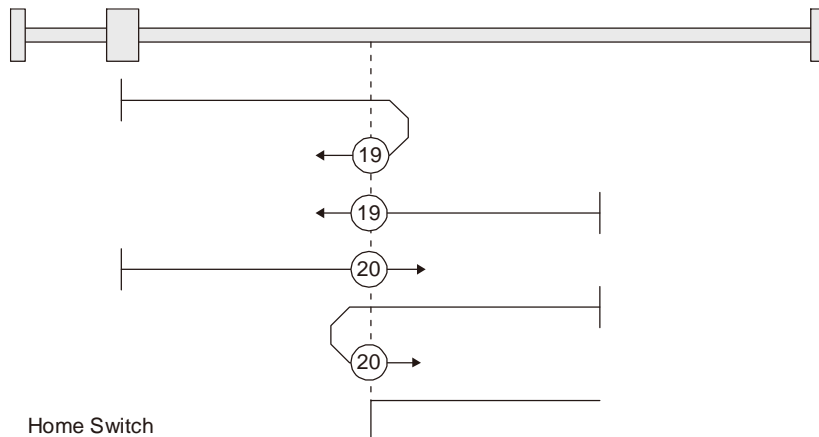

5) Method 33 and 34: Homing on index pulse

These home position return types set the Z-phase detected first as a home position. The operation is the same as that of the dogless Z-phase reference home position return except that the creep speed is applied at the start.

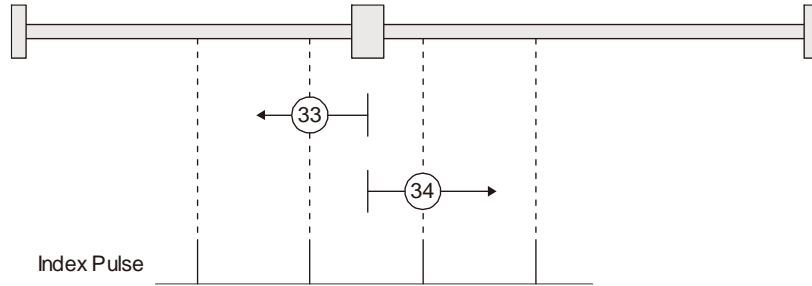

6) Method 35 and 37: Homing on current position

These home position return types set the current position as a home position. The operation is the same as that of the data set type home position return; however, these types can be executed even during servo-off.



(b) Operation example of the CiA 402-type Homing method

The following shows an operation example of the home position return in the CiA 402-type Homing method.

- 1) Method 3 (Homing on positive home switch and index pulse) and Method 5 (Homing on negative home switch and index pulse)

The following figure shows the operation of Homing method 3. The operation direction of Homing method 5 is opposite to that of Homing method 3.

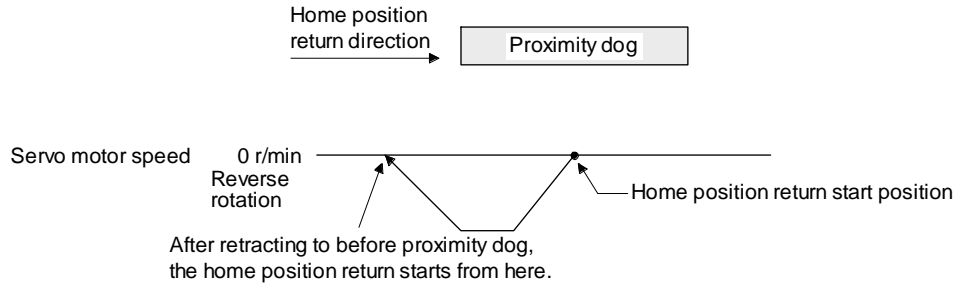
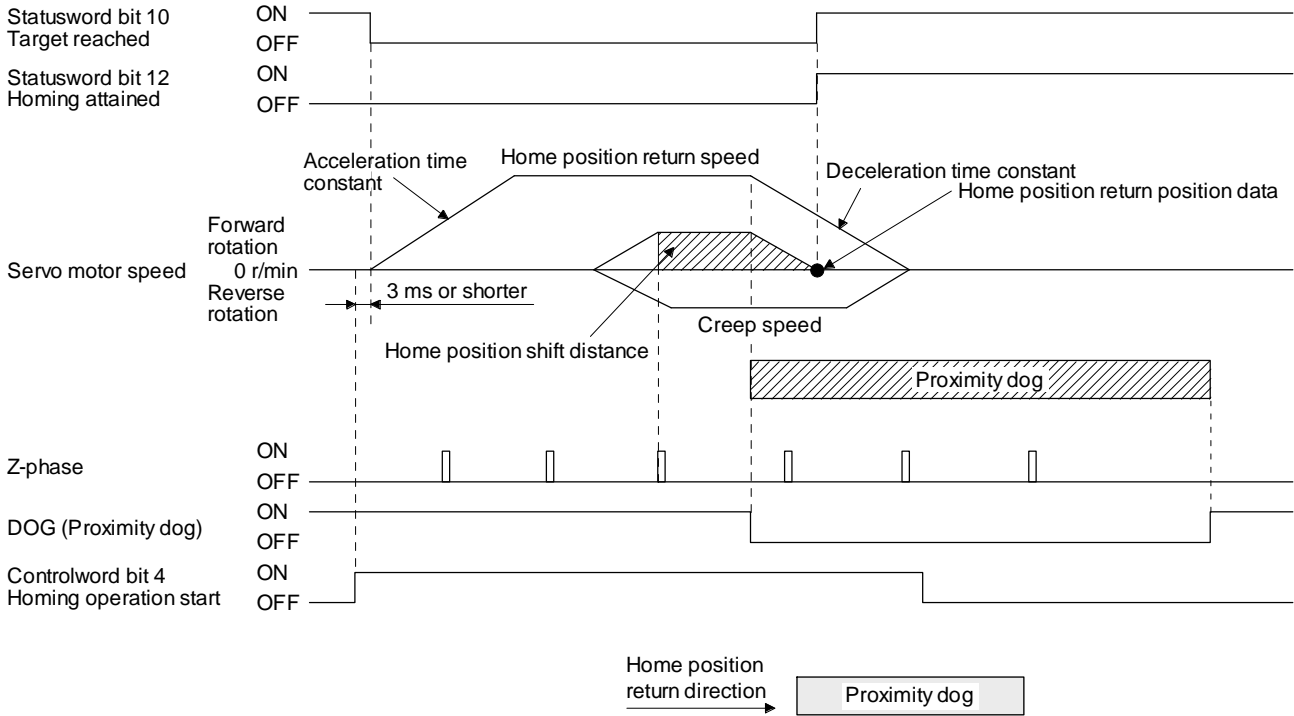

When a home position return is started from the proximity dog

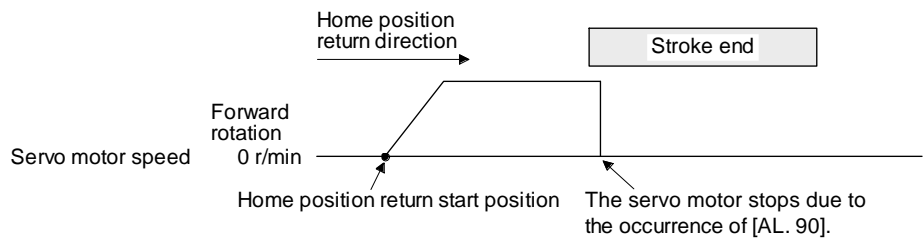

When the stroke end is detected

- 2) Method 4 (Homing on positive home switch and index pulse) and Method 6 (Homing on negative home switch and index pulse)

The following figure shows the operation of Homing method 4. The operation direction of Homing method 6 is opposite to that of Homing method 4.

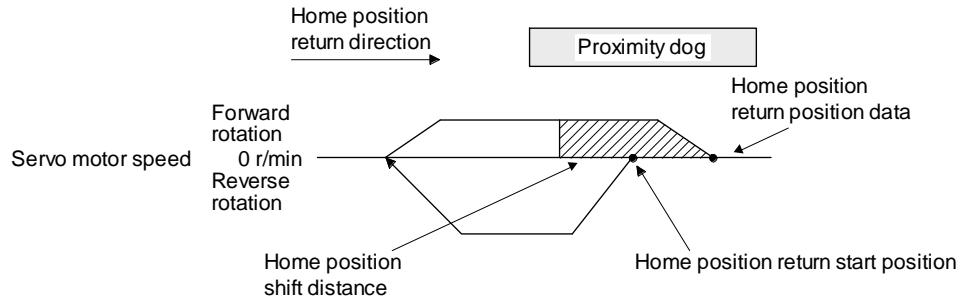
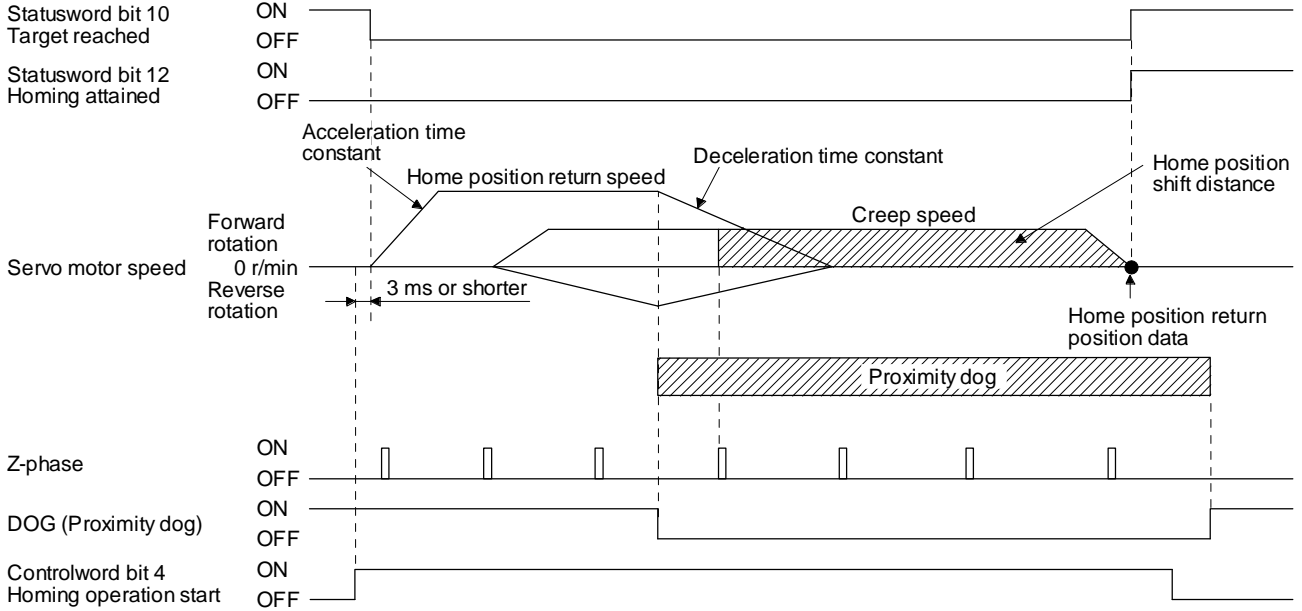

When a home position return is started from the proximity dog

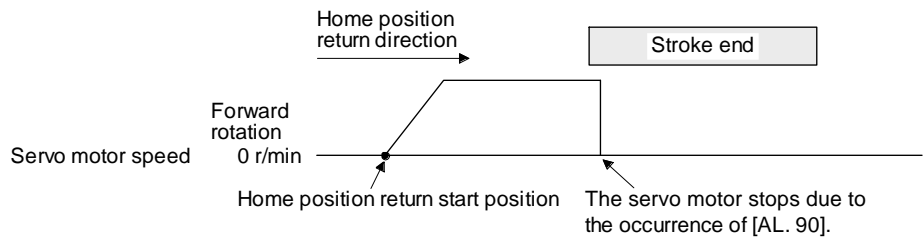

When the stroke end is detected

3) Method 7 and Method 11 (Homing on home switch and index pulse)

The following figure shows the operation of Homing method 7. The operation direction of Homing method 11 is opposite to that of Homing method 7.

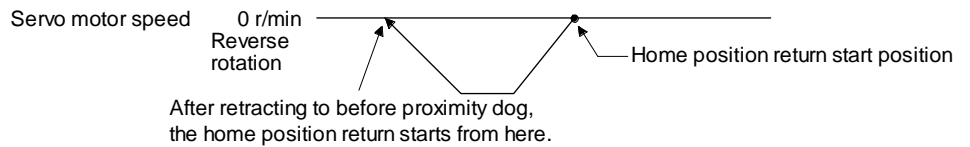
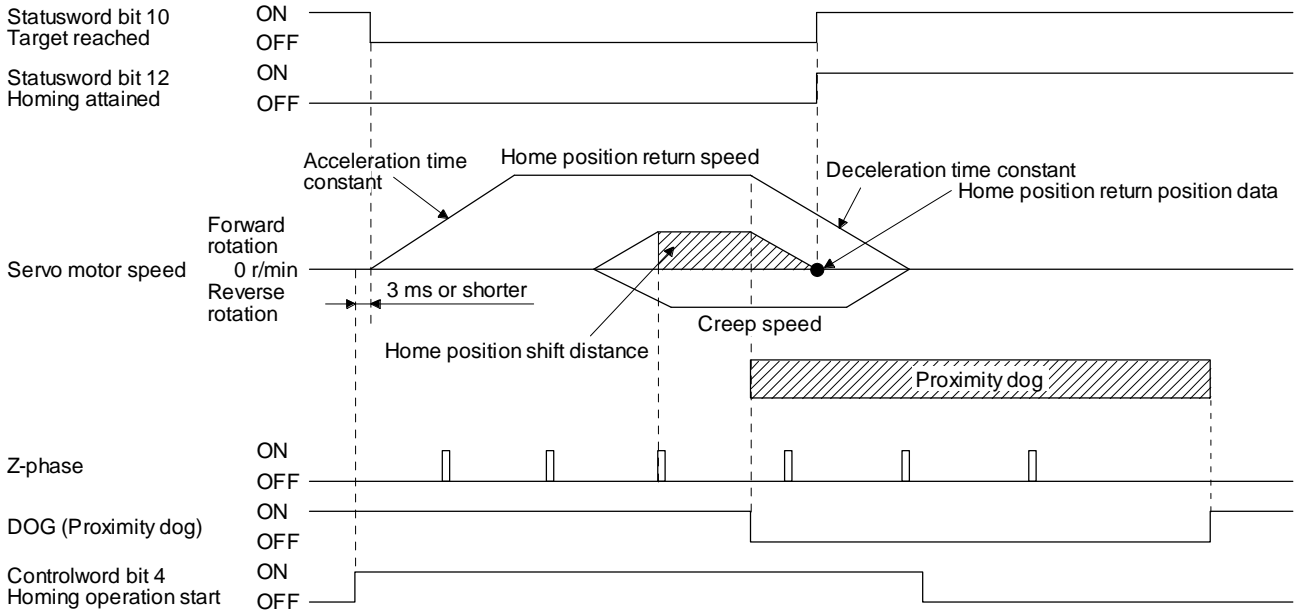

When a home position return is started from the proximity dog

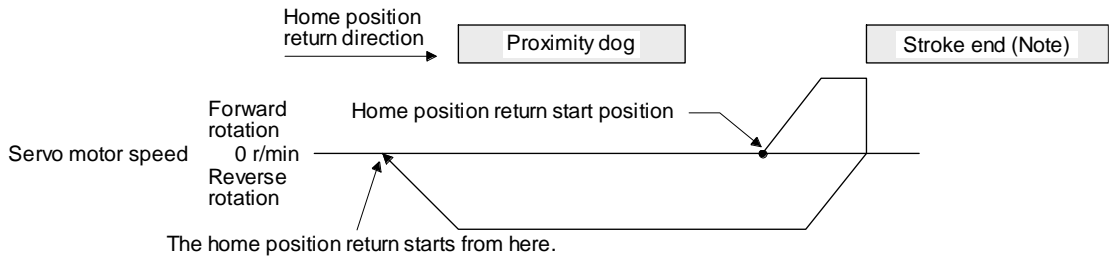

No	The software limit cannot be used with these functions.
te.	

When the movement is returned at the stroke end

4) Method 8 and Method 12 (Homing on home switch and index pulse)

The following figure shows the operation of Homing method 8. The operation direction of Homing method 12 is opposite to that of Homing method 8.

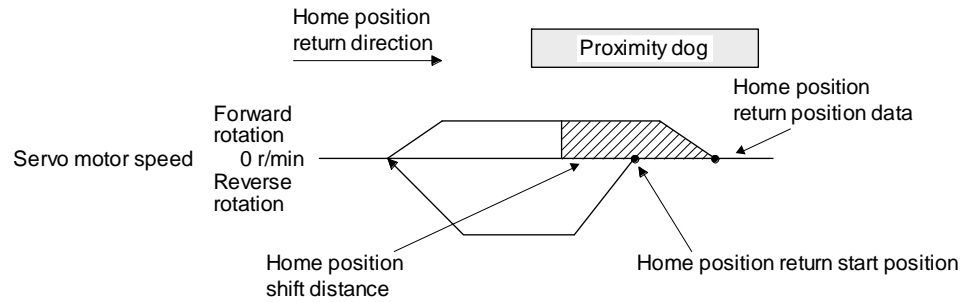
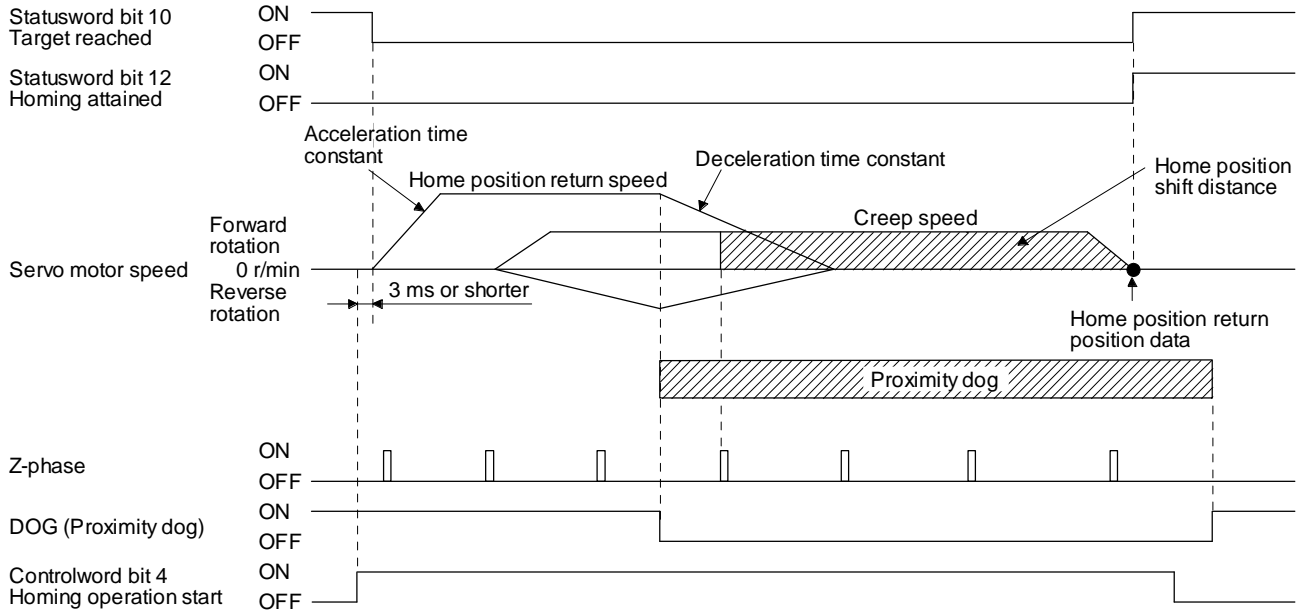

When a home position return is started from the proximity dog

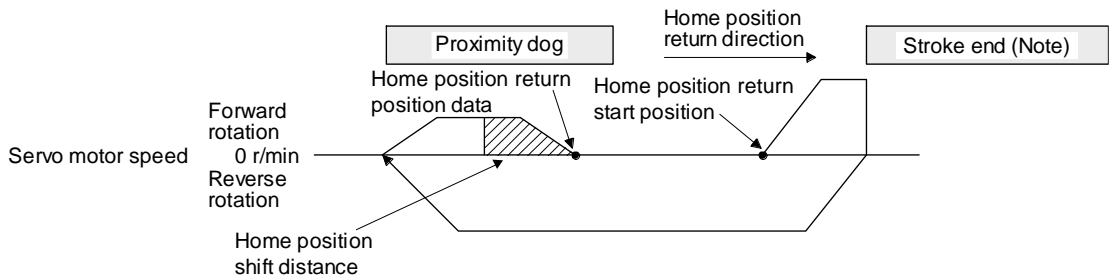

No te.	The software limit cannot be used with these functions.
-----------	---

When the movement is returned at the stroke end

5) Method 19 and Method 21 (Homing without index pulse)

The following figure shows the operation of Homing method 19. The operation direction of Homing method 21 is opposite to that of Homing method 19.

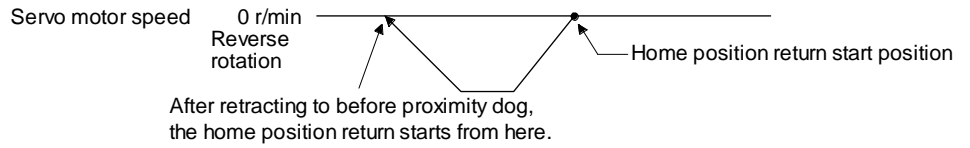
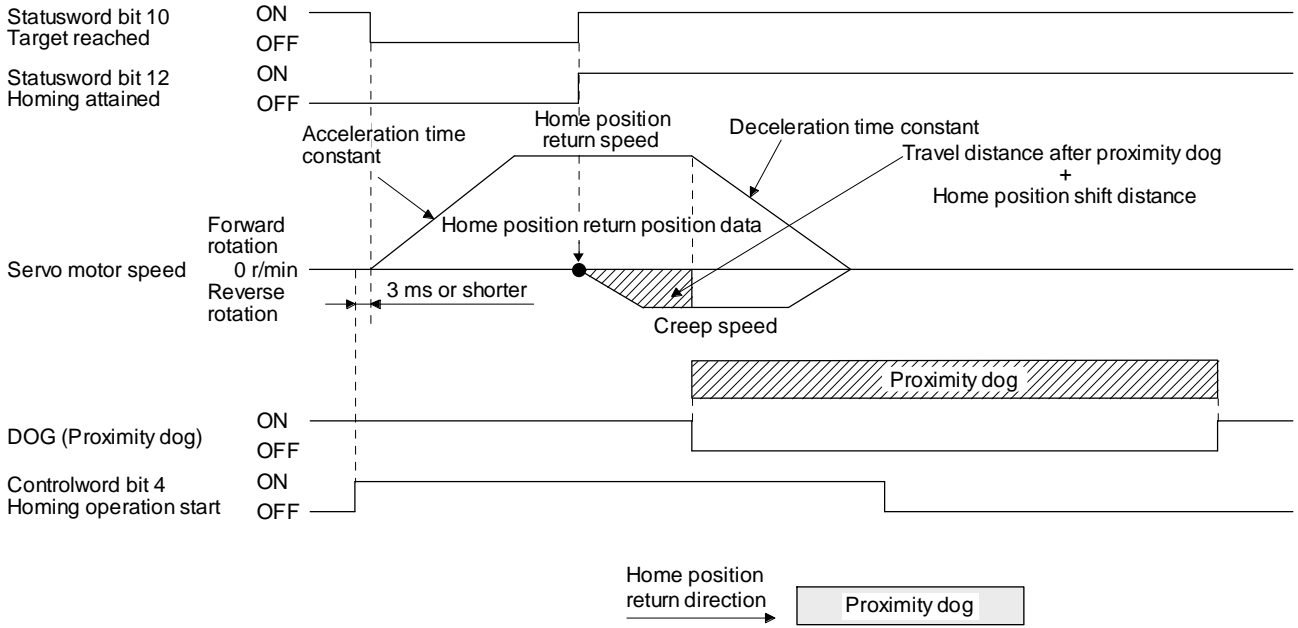

When a home position return is started from the proximity dog

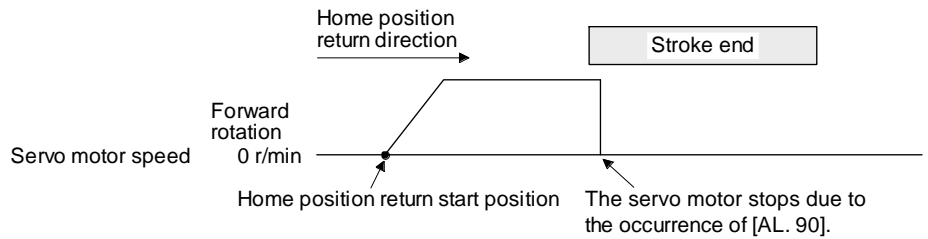

When the stroke end is detected

6) Method 20 and Method 22 (Homing without index pulse)

The following figure shows the operation of Homing method 20. The operation direction of Homing method 22 is opposite to that of Homing method 20.

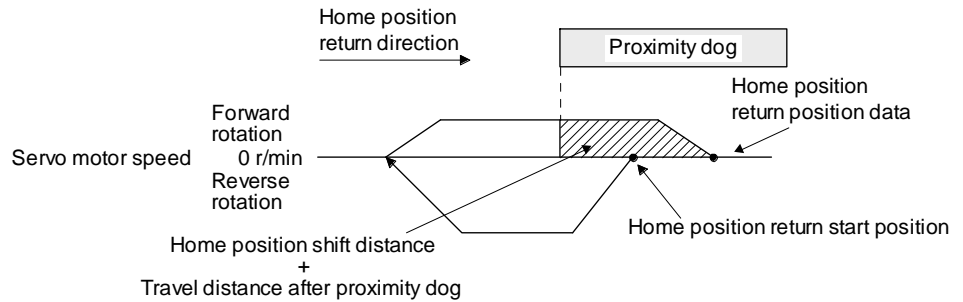
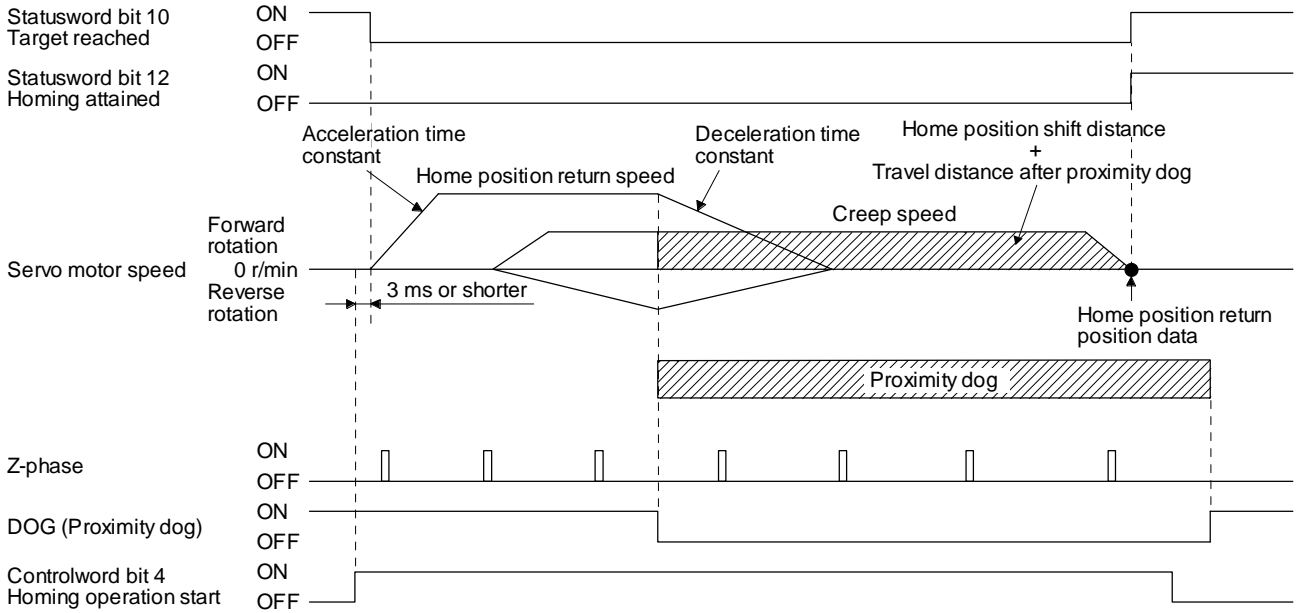

When a home position return is started from the proximity dog

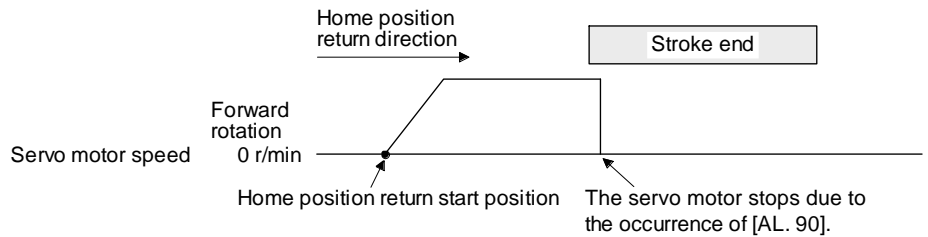

When the stroke end is detected

7) Method 23 and Method 27 (Homing without index pulse)

The following figure shows the operation of Homing method 23. The operation direction of Homing method 27 is opposite to that of Homing method 23.

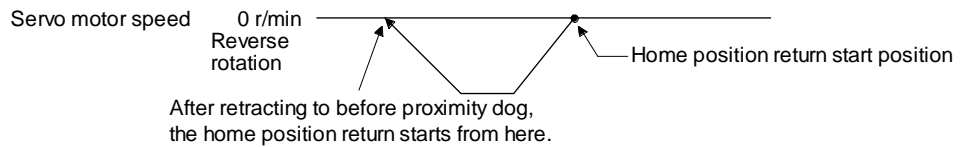
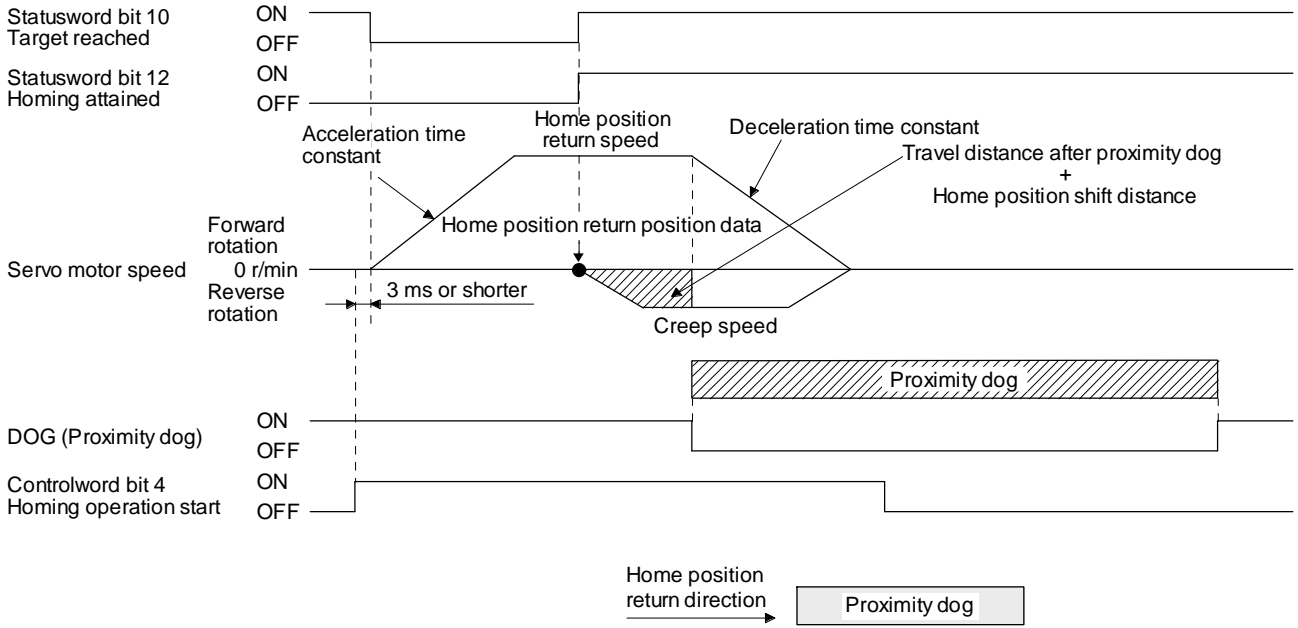

When a home position return is started from the proximity dog

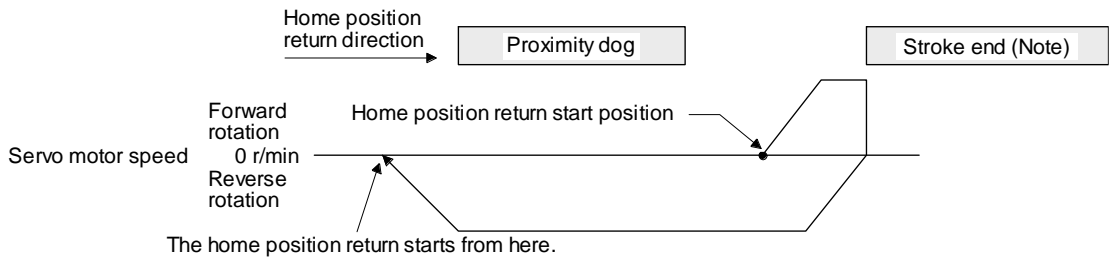

No te.	The software limit cannot be used with these functions.
--------	---

When the movement is returned at the stroke end

8) Method 24 and Method 28 (Homing without index pulse)

The following figure shows the operation of Homing method 24. The operation direction of Homing method 28 is opposite to that of Homing method 24.

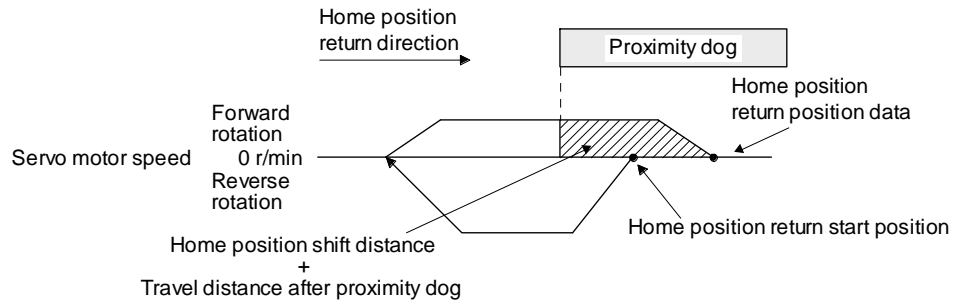
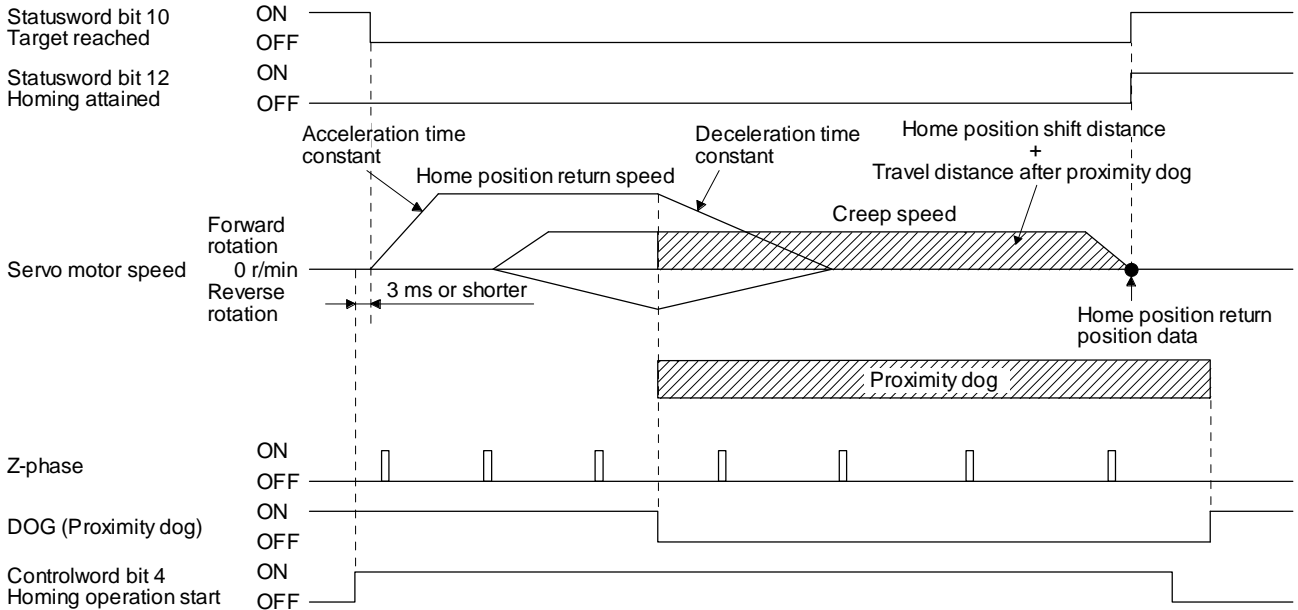

When a home position return is started from the proximity dog

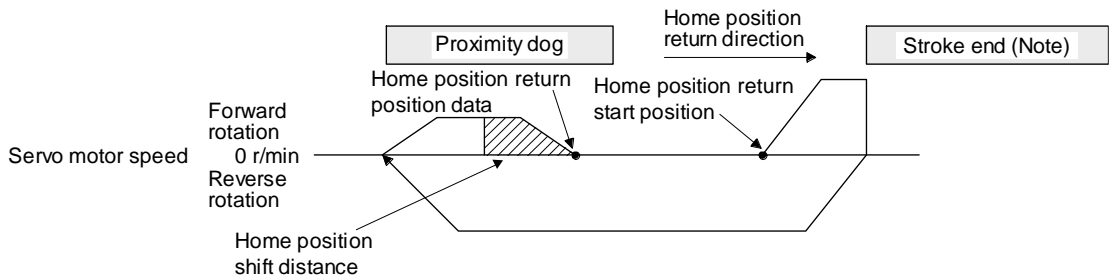

No te.	The software limit cannot be used with these functions.
--------	---

When the movement is returned at the stroke end

9) Method 33 and Method 34 (Homing on index pulse)

The following figure shows the operation of Homing method 34. The operation direction of Homing method 33 is opposite to that of Homing method 34.

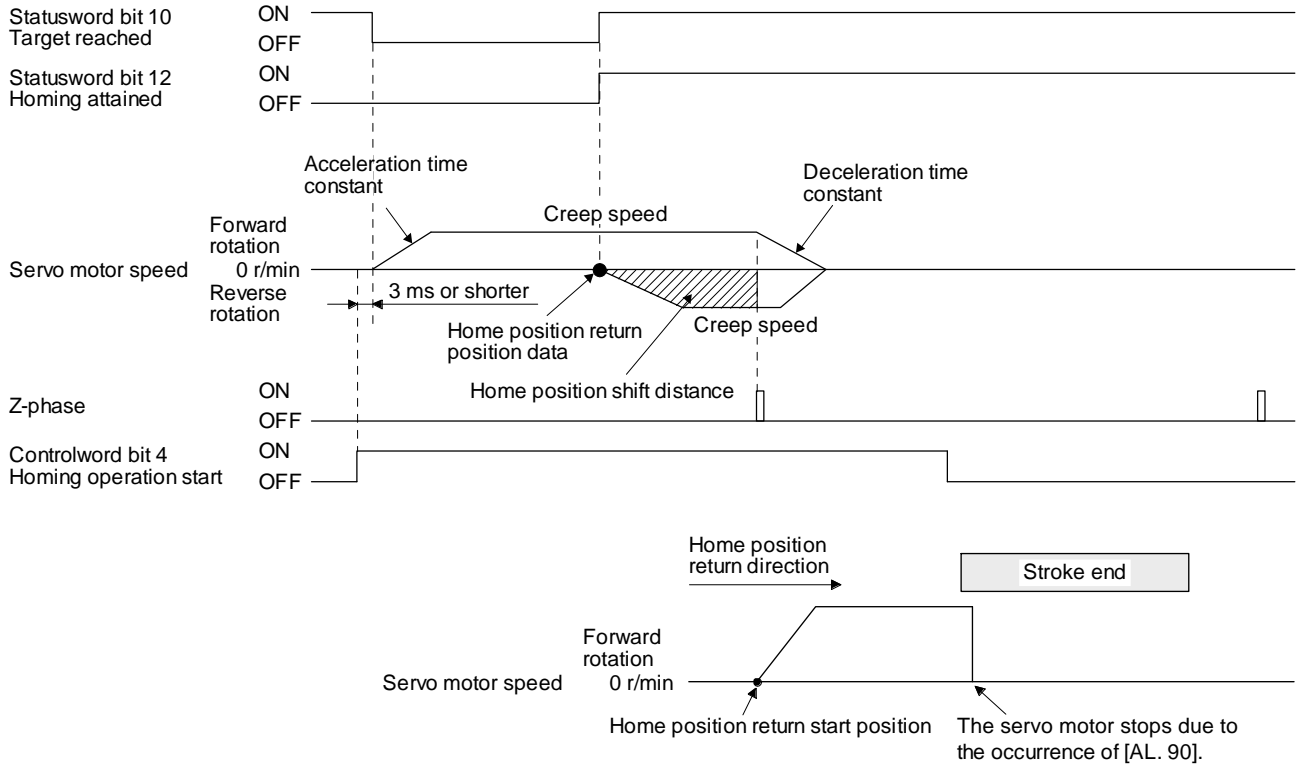

When the stroke end is detected

10) Method 35 and Method 37 (Homing on current position)

The following figure shows the operation of Homing method 35 and Homing method 37. These methods can be performed in the servo-off status.

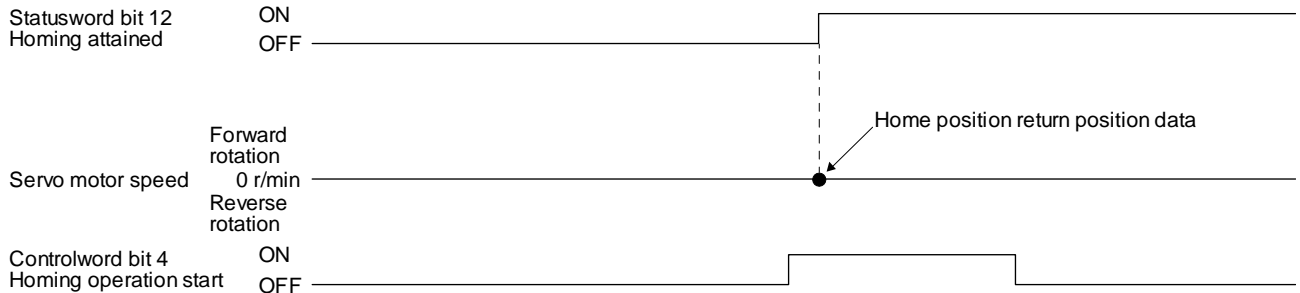

(6) Operation example of Manufacturer-specific Homing method

The following shows an operation example of the Manufacturer-specific home return.

(a) Method -1 and -33

1) Dog type home position return

The following figure shows the operation of Homing method -1. The operation direction of Homing method -33 is opposite to that of Homing method -1.

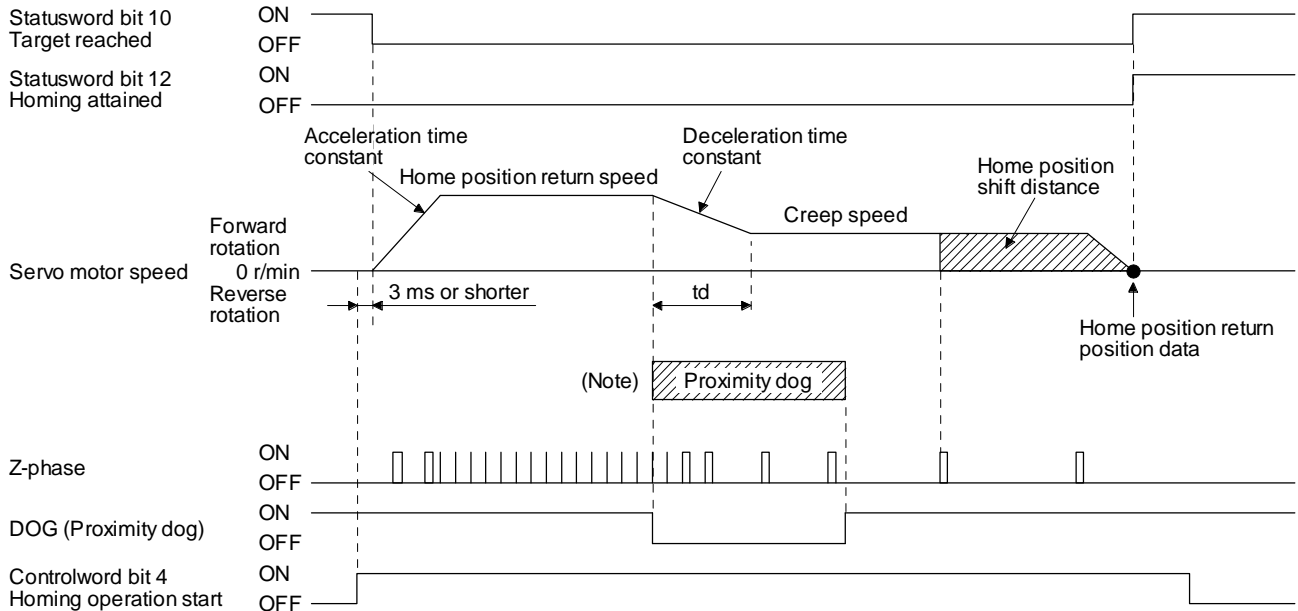

No te.	After the front end of the proximity dog is detected, if the distance after proximity dog is traveled without reaching the creep speed, [AL. 90] occurs. Set the travel distance after proximity dog enough for deceleration from the home position return speed to the creep speed.
--------	--

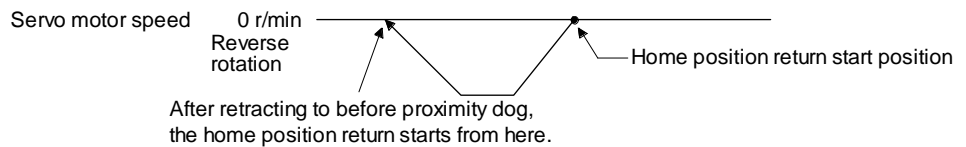

When a home position return is started from the proximity dog

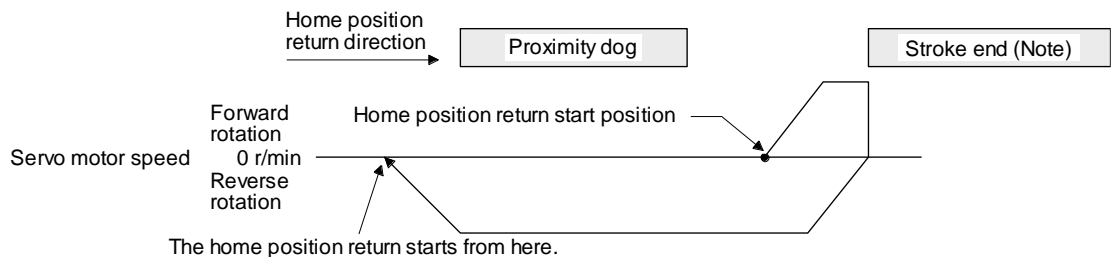

Note.	The software limit cannot be used with these functions.
-------	---

When the movement is returned at the stroke end

2) Torque limit changing dog type home position return

The following figure shows the operation of Homing method -1 in the indexer method. The operation direction of Homing method -33 is opposite to that of Homing method -1.

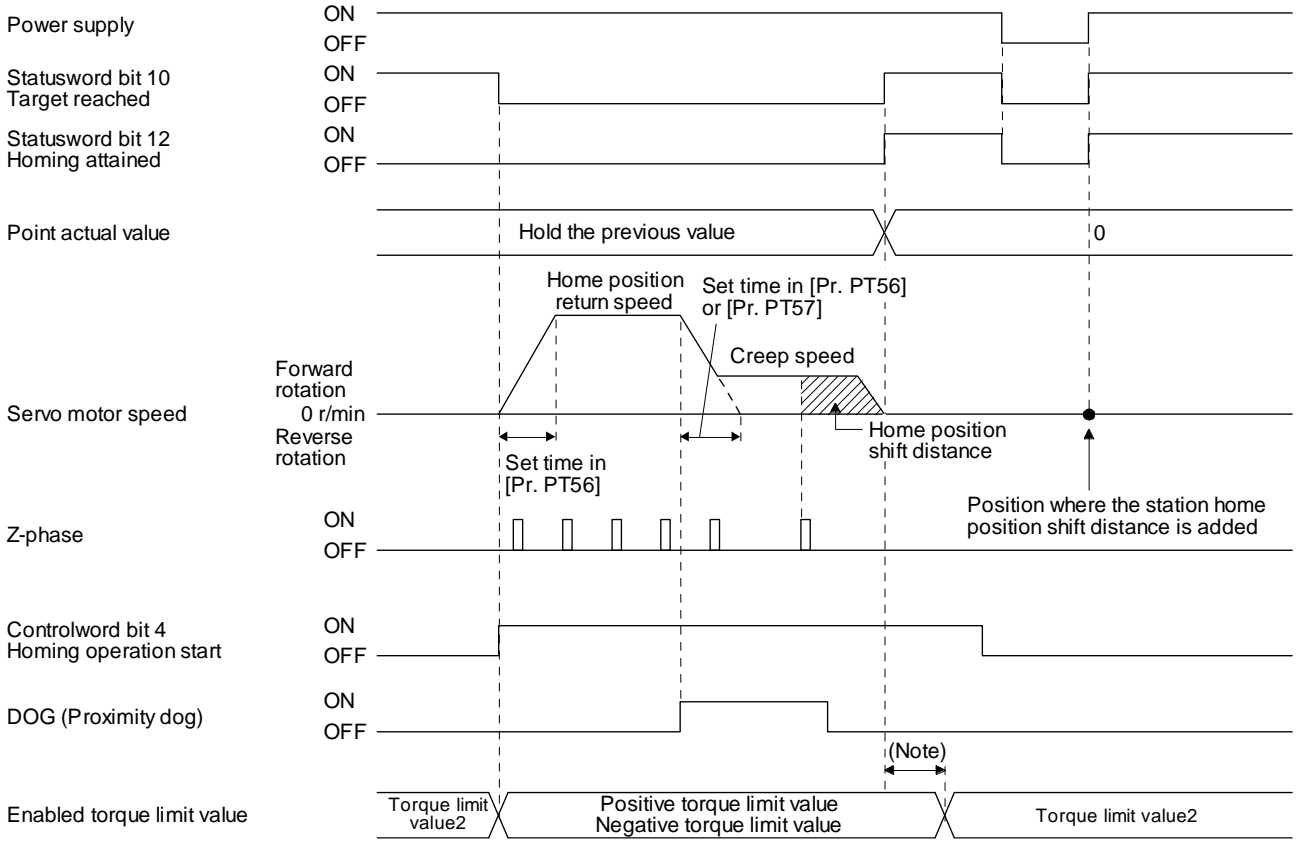

Note.	A delay time can be set with [Pr. PT39].
-------	--

(b) Method -2 and -34 (Count type home position return)

POINT

● For the count type home position return, after the front end of the proximity dog is detected, the position is shifted by the distance set in the travel distance after proximity dog. Then, the first Z-phase is set as the home position. Therefore, when the on-time of the proximity dog is 10 ms or more, the length of the proximity dog has no restrictions. Use this home position return type when the dog type home position return cannot be used because the length of the proximity dog cannot be reserved or other cases.

The following figure shows the operation of Homing method -2. The operation direction of Homing method -34 is opposite to that of Homing method -2.

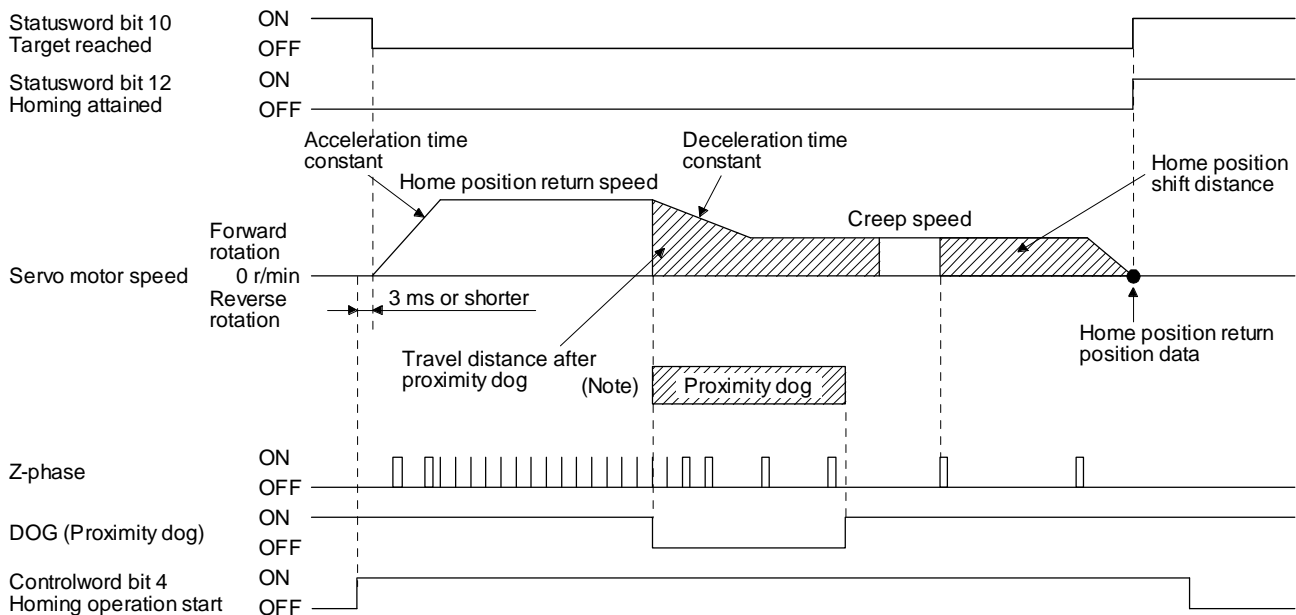

Note. After the front end of the proximity dog is detected, if the distance after proximity dog is traveled without reaching the creep speed, [AL. 90] occurs. Set the travel distance after proximity dog enough for deceleration from the home position return speed to the creep speed.

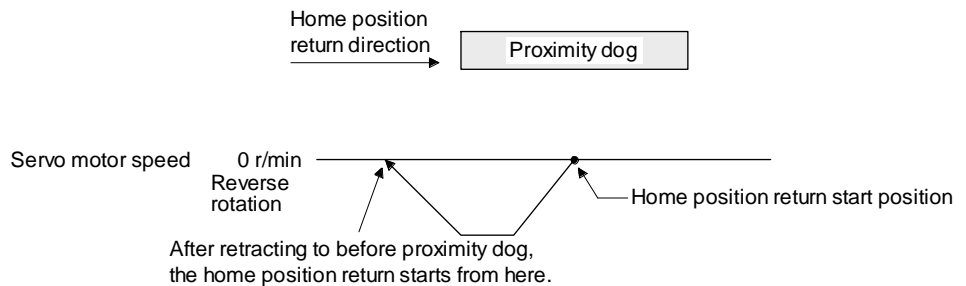

When a home position return is started from the proximity dog

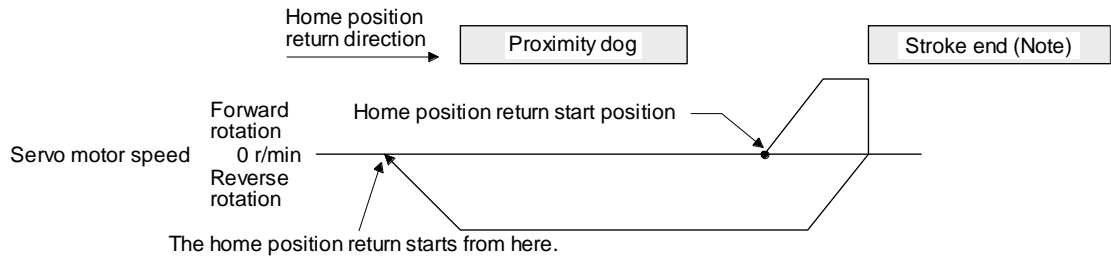

No	The software limit cannot be used with these functions.
----	---

When the movement is returned at the stroke end

(c) Method -3

1) Data set type home position return

The following figure shows the operation of Homing method -3. This type cannot be executed during servo-off.

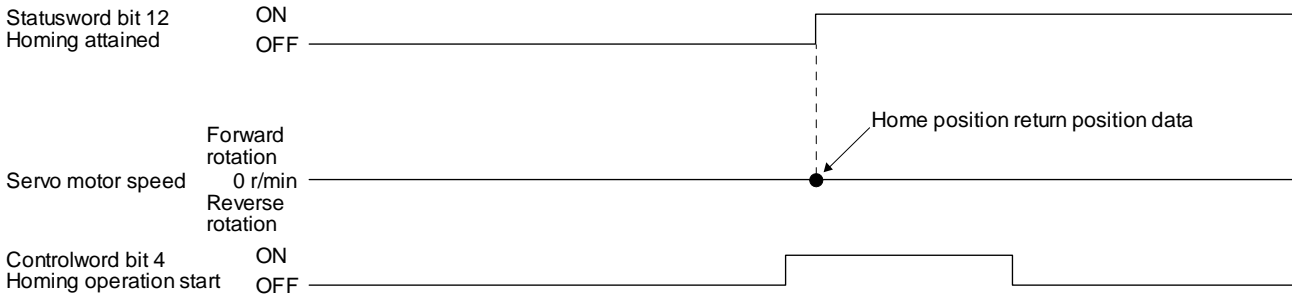

2) Torque limit changing data set type home position return

The following figure shows the operation of Homing method -3 in the indexer method. This type cannot be executed during servo-off.

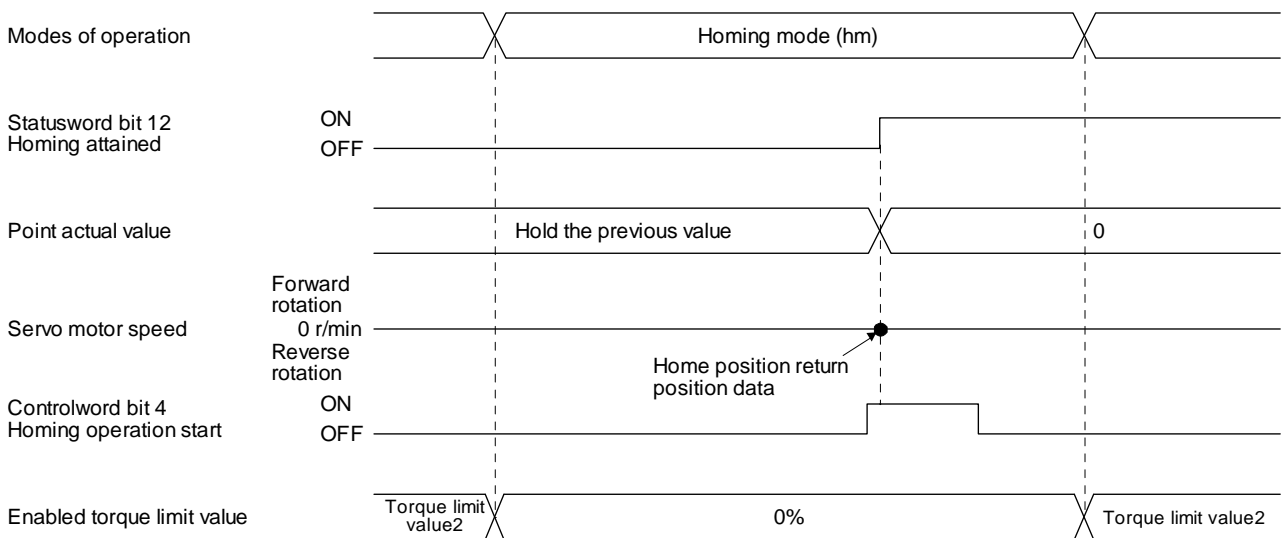

(d) Method -4 and -36 (stopper type home position return)

POINT

● Since the workpiece collides with the mechanical stopper, the home position return speed must be low enough.

The following figure shows the operation of Homing method -4. The operation direction of Homing method -36 is opposite to that of Homing method -4.

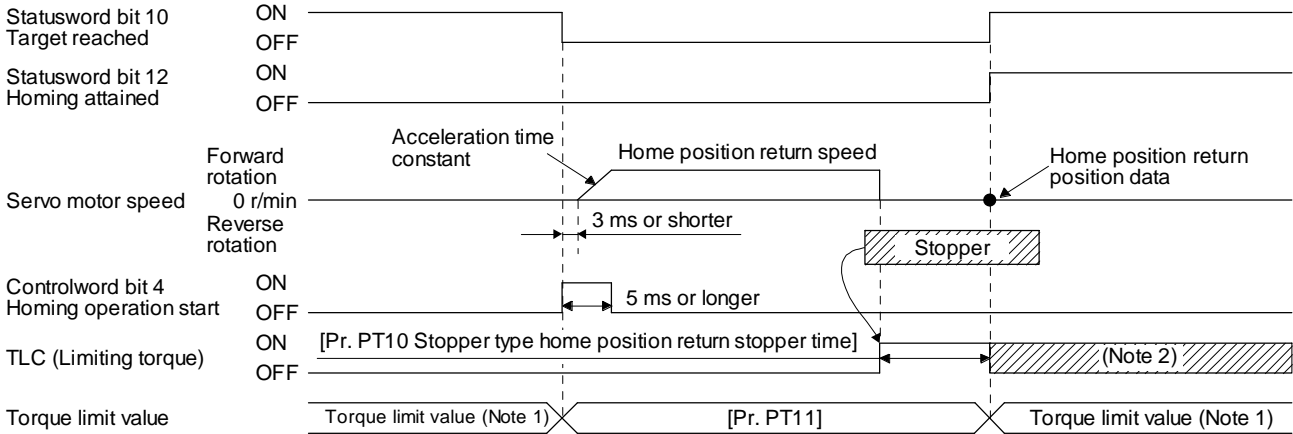

Note	1	When Method -4 is set, the torque limit value of Positive torque limit value (P24800) is applied. When Method -36 is set, the torque limit value of Negative torque limit value (P24801) is applied.
	2	If the torque limit value is reached, TLC remains on after the home position return is completed.

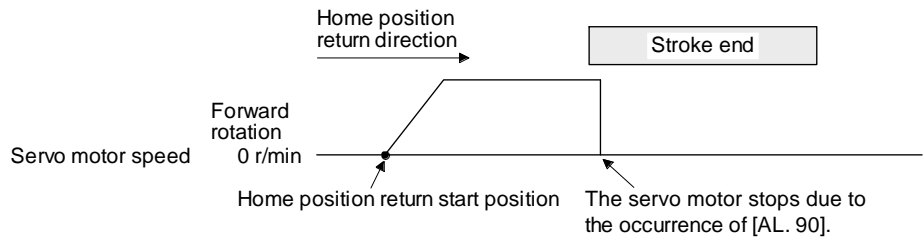

When the stroke end is detected

(e) Method -6 and -38 (dog type rear end reference home position return)

POINT

● This home position return type depends on the timing of reading DOG (Proximity dog) that has detected the rear end of the proximity dog. Therefore, when the creep speed is set to 100 r/min and a home position return is performed, the home position has an error of $\pm (\text{Encoder resolution}) \times 100/65536$ [pulse]. The higher the creep speed, the greater the error of the home position.

The following figure shows the operation of Homing method -6. The operation direction of Homing method -38 is opposite to that of Homing method -6.

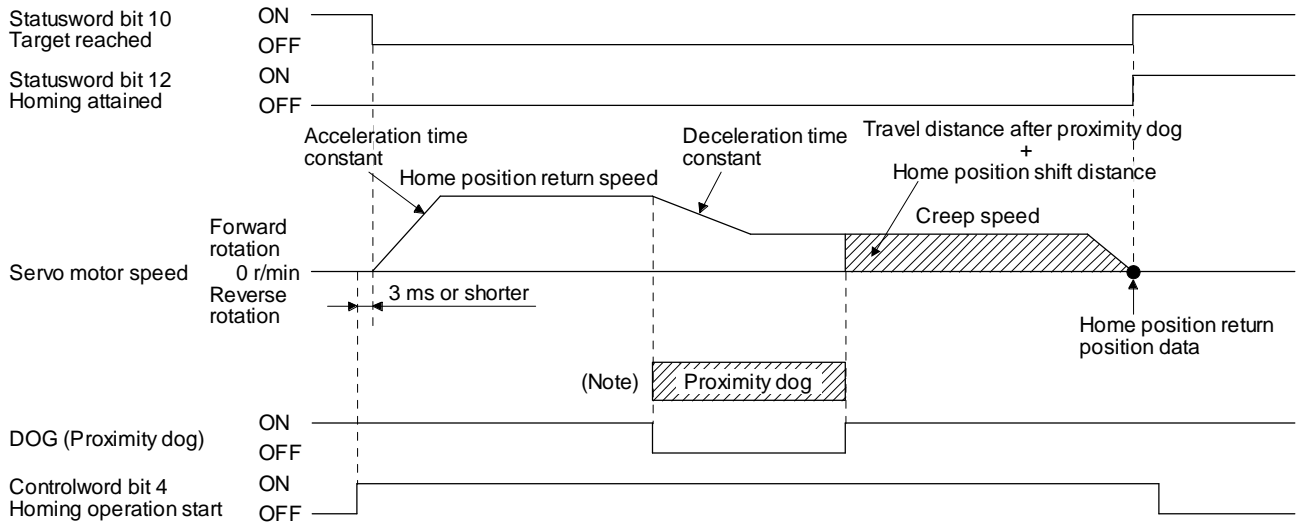

No te. After the front end of the proximity dog is detected, if the rear end of the proximity dog is detected without reaching the creep speed, [AL. 90] occurs. Check the length of the proximity dog or check the home position return speed and creep speed.

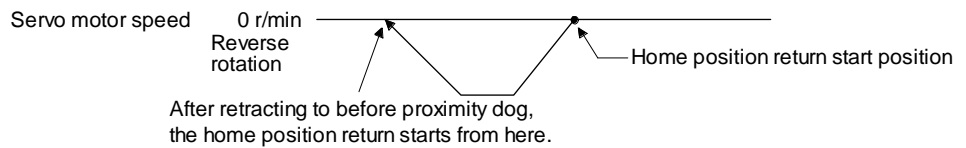

When a home position return is started from the proximity dog

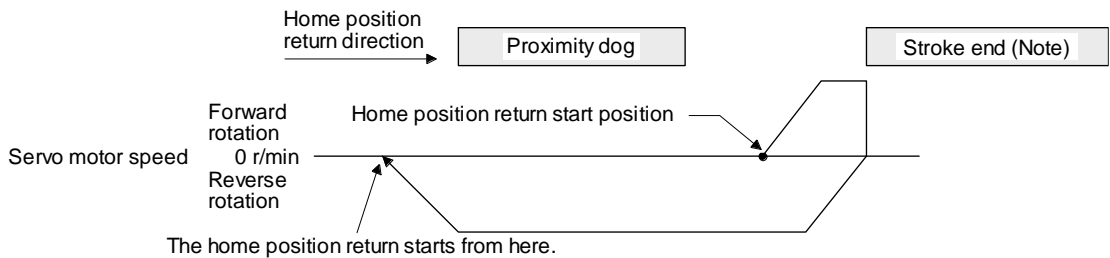

Note. The software limit cannot be used with these functions.

When the movement is returned at the stroke end

(f) Method -7 and -39 (count type front end reference home position return)

POINT

● This home position return type depends on the timing of reading DOG (Proximity dog) that has detected the front end of the proximity dog. Therefore, when the creep speed is set to 100 r/min and a home position return is performed, the home position has an error of $\pm (\text{Encoder resolution}) \times 100/65536$ [pulse]. The faster home position return speed sets a larger error in the home position.

The following figure shows the operation of Homing method -7. The operation direction of Homing method -39 is opposite to that of Homing method -7.

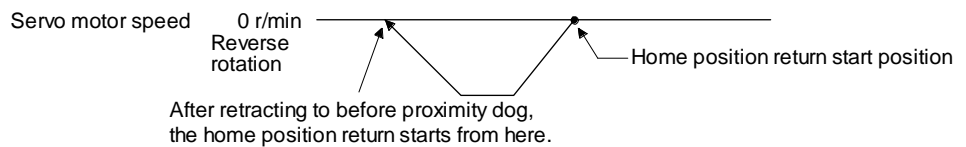
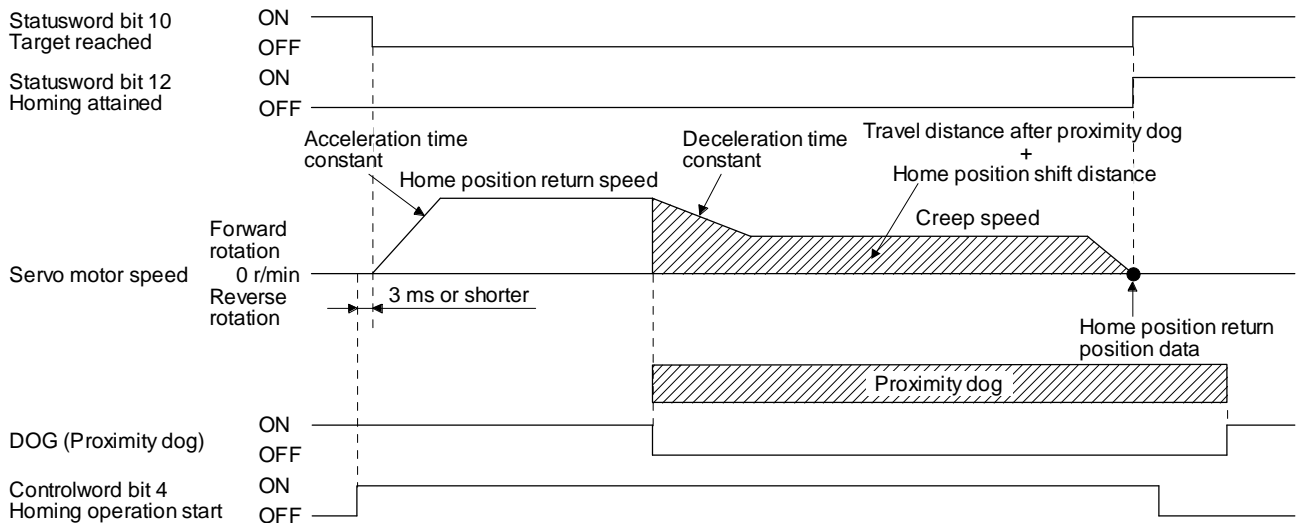

When a home position return is started from the proximity dog

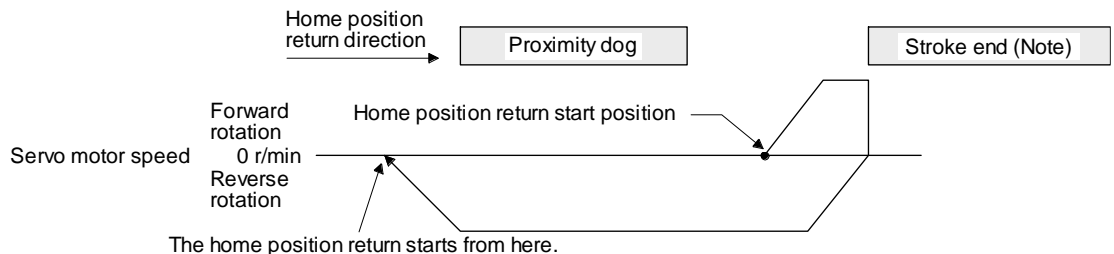

No te.	The software limit cannot be used with these functions.
--------	---

When the movement is returned at the stroke end

(g) Method -8 and -40 (dog cradle type home position return)

The following figure shows the operation of Homing method -8. The operation direction of Homing method -40 is opposite to that of Homing method -8.

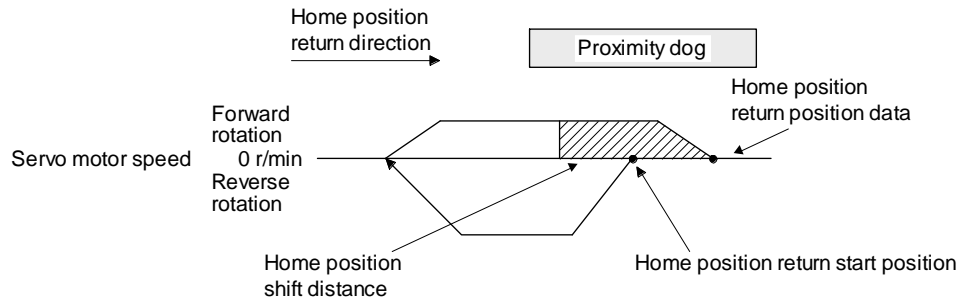
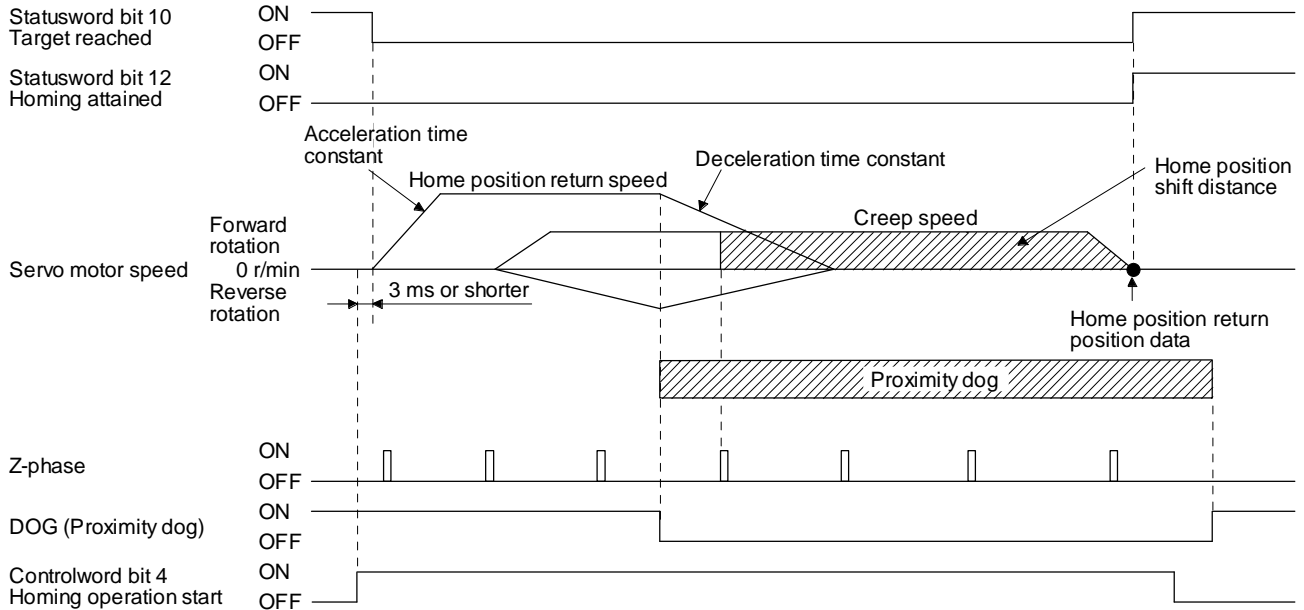

When a home position return is started from the proximity dog

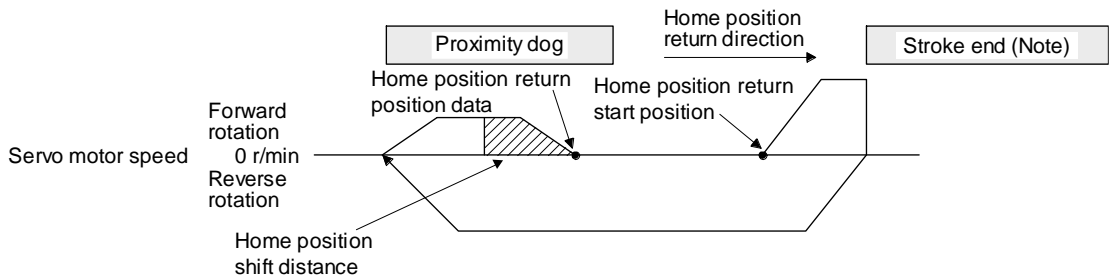

No te.	The software limit cannot be used with these functions.
--------	---

When the movement is returned at the stroke end

(h) Method -9 and -41 (dog type last Z-phase reference home position return)

The following figure shows the operation of Homing method -9. The operation direction of Homing method -41 is opposite to that of Homing method -9.

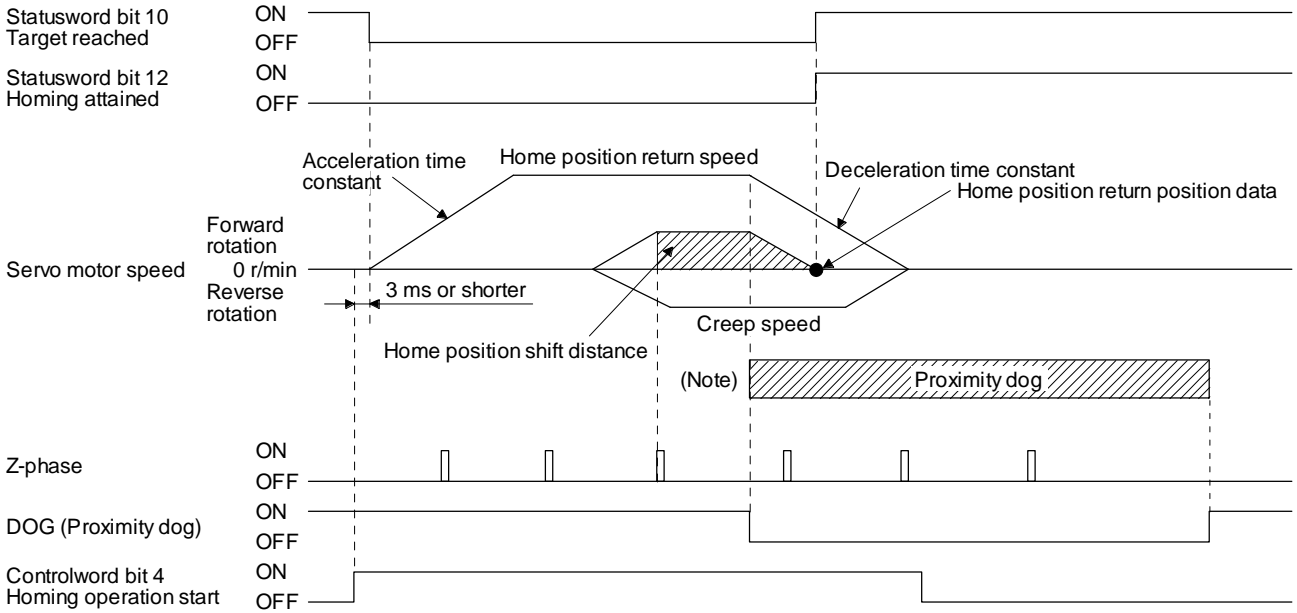

No	After the front end of the proximity dog is detected, if the rear end of the proximity dog is detected without stop, [AL. 90] occurs.
te.	Check the length of the proximity dog or check the home position return speed and creep speed.

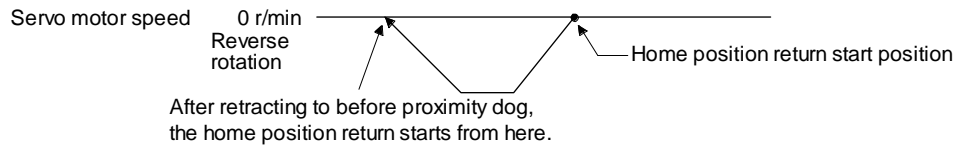

When a home position return is started from the proximity dog

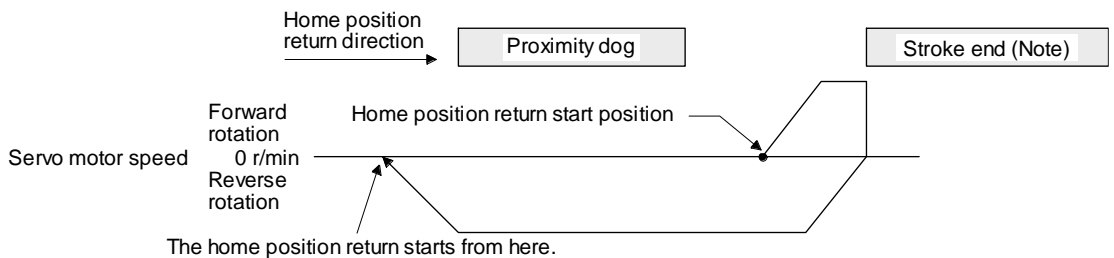

No	The software limit cannot be used with these functions.
te.	

When the movement is returned at the stroke end

(i) Method -10 and -42 (dog type front end reference home position return)

The following figure shows the operation of Homing method -10. The operation direction of Homing method -42 is opposite to that of Homing method -10.

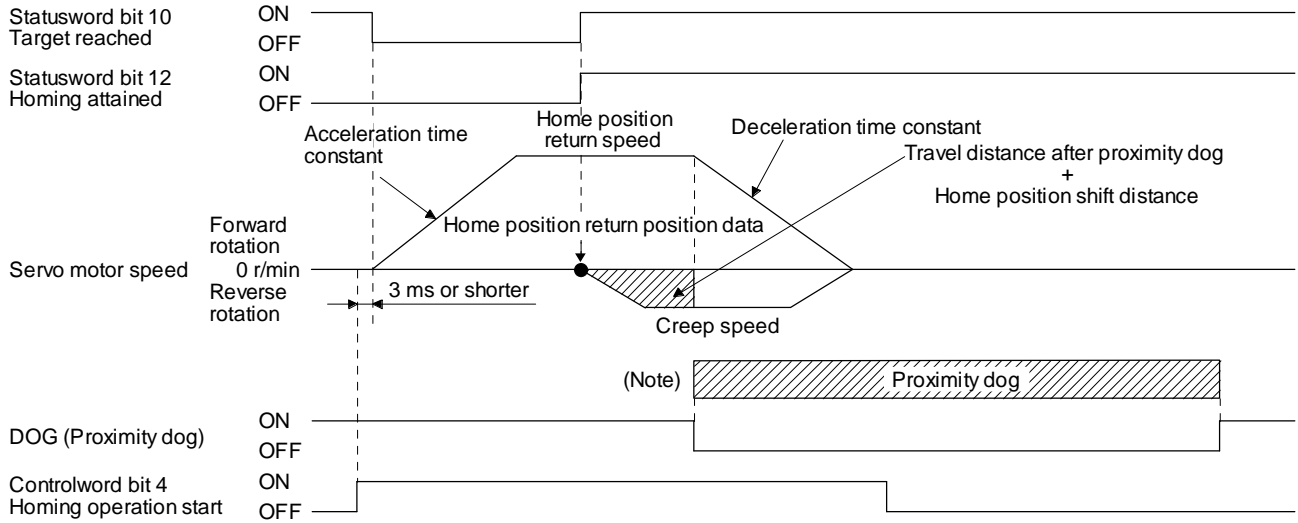

No te.	After the front end of the proximity dog is detected, if the rear end of the proximity dog is detected without reaching the creep speed, [AL. 90] occurs. Check the length of the proximity dog or check the home position return speed and creep speed.
--------	--

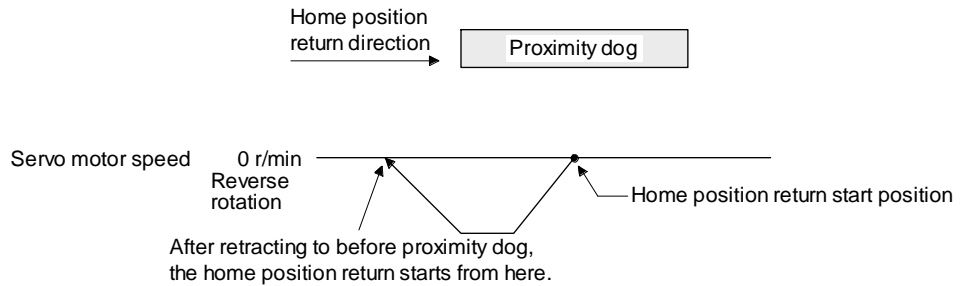

When a home position return is started from the proximity dog

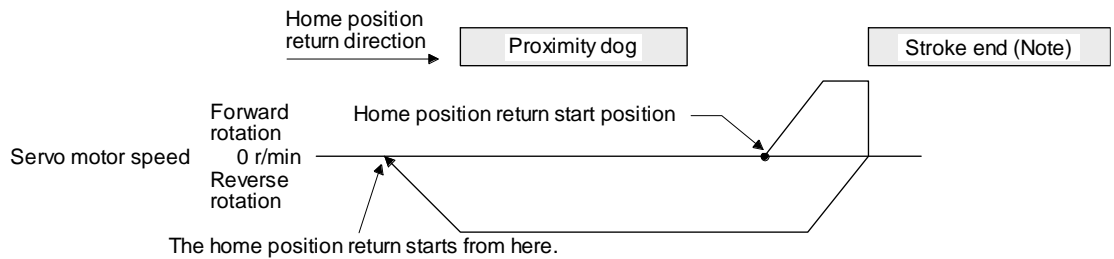

No te.	The software limit cannot be used with these functions.
--------	---

When the movement is returned at the stroke end

(j) Method -11 and -43 (dogless Z-phase reference home position return)

The following figure shows the operation of Homing method -11. The operation direction of Homing method -43 is opposite to that of Homing method -11.

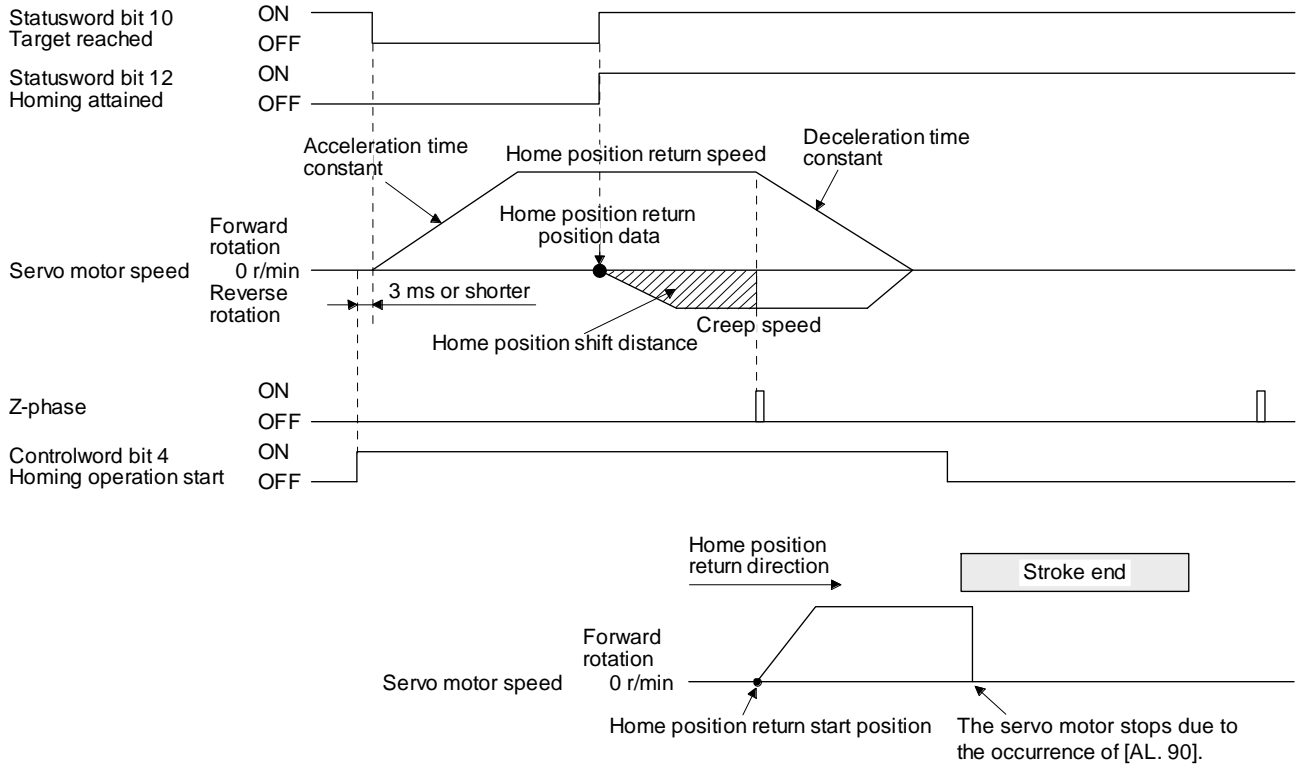

When the stroke end is detected

20. 6. 7 Point table mode (pt)

The following shows the functions and related objects of the point table mode (pt).

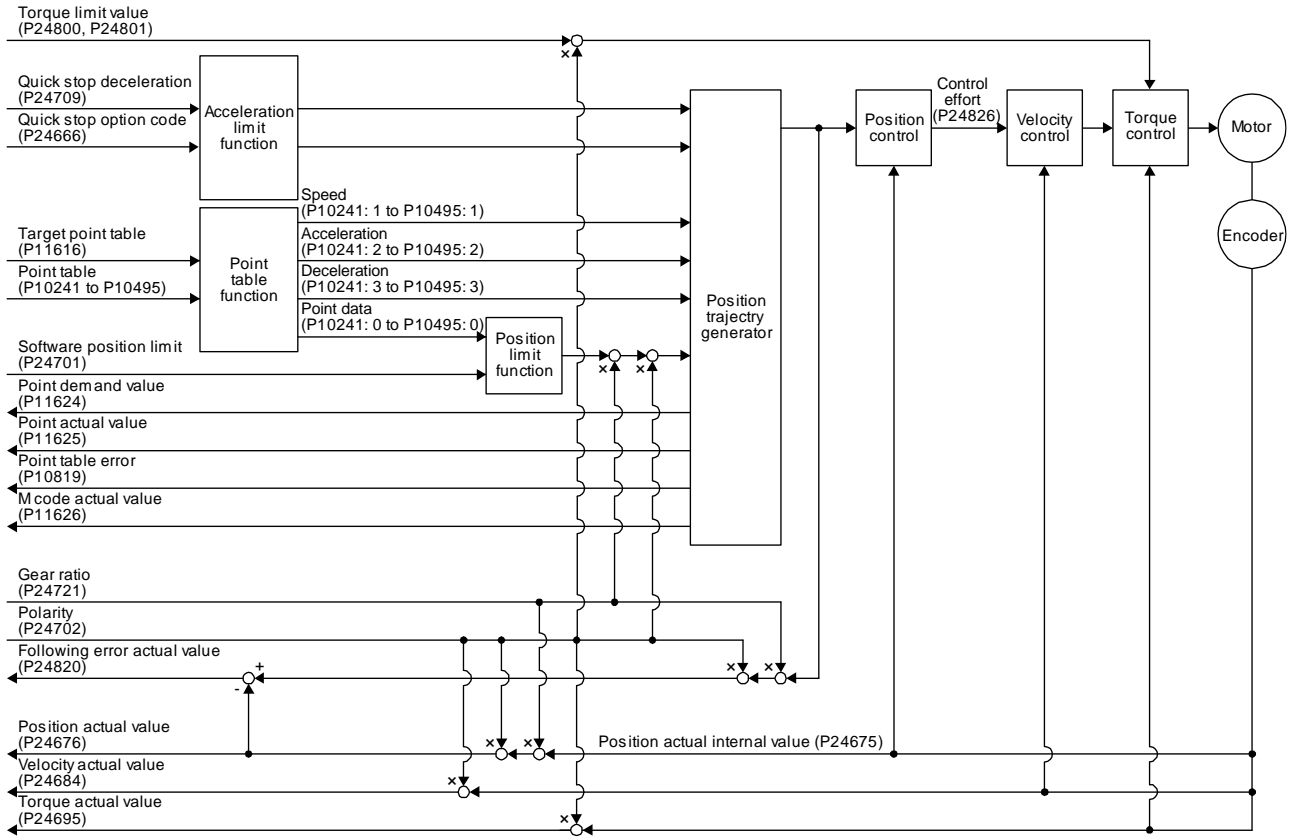

(1) Related object

PNU	Sub	Access	Name	Type	Default value	Description
24699	0	R/W	Min position range limit	Array [2] Integer32		Minimum value of the position range limit The value is automatically set according to the setting of "Position data unit" of [Pr. PT01]. mm/inch/pulse: -2147483648
	1	R/W	Max position range limit			Maximum value of the position range limit The value is automatically set according to the setting of "Position data unit" of [Pr. PT01]. mm/inch/pulse: 2147483647
24701	0	R/W	Min position limit	Array [2] Integer32	0	Minimum position address (Pos units)
	1	R/W	Max position limit		0	Maximum position address (Pos units)
24709	0	R/W	Quick stop deceleration	Unsigned32	100	Deceleration at deceleration to a stop by Quick stop Unit: ms
24666	0	R/W	Quick stop option code	Integer16	2	Operation setting for Quick stop Refer to section 8.10.

20. PROFINET COMMUNICATION

PNU	Sub	Access	Name	Type	Default value	Description
24675	0	R	Position actual internal value	Integer32		Current position (Enc inc)
24676	0	R	Position actual value	Integer32		Current position (Pos units)
24684	0	R	Velocity actual value	Integer32		Current speed Unit: Vel units (0.01 r/min or 0.01 mm/s)
24695	0	R	Torque actual value	Integer16		Current torque Unit: 0.1% (rated torque of 100%)
24722	0	R/W	Feed	Array [2] Unsigned32		Travel distance setting Refer to section 9.3.12 (4).
	1	R/W	Shaft revolutions		1	Number of servo motor shaft revolutions Refer to section 9.3.12 (4).
24820	0	R	Following error actual value	Integer32		Droop pulses (Pos units)
24826	0	R	Control effort	Integer32		Position control loop output (speed command) Unit: Vel units (0.01 r/min or 0.01 mm/s)
24800	0	R/W	Positive torque limit value	Unsigned16	10000	Torque limit value (forward) Unit: 0.1% (rated torque of 100%)
24801	0	R/W	Negative torque limit value	Unsigned16	10000	Torque limit value (reverse) Unit: 0.1% (rated torque of 100%)
24721	0	R/W	Motor revolutions	Array [2] Unsigned32	1	Gear ratio: Number of revolutions of the servo motor shaft (numerator)
	1	R/W	Shaft revolutions		1	Gear ratio: Number of revolutions of the drive shaft (denominator)
24702	0	R/W	Polarity	Unsigned8	0	Polarity selection Bit 7: Position POL Bit 6: Velocity POL Bit 5: Torque POL Refer to section 8.5.
24744	0	R/W	SI unit position	Unsigned32	0	SI unit position The value is automatically set according to the setting of "Position data unit" of [Pr. PT01]. Refer to section 9.3.12 (5).
24745	0	R/W	SI unit velocity	Unsigned32	0	SI unit velocity 0.01 r/min or 0.01 mm/s FB010300h (0.01 mm/s) FEB44700h (0.01 r/min)
11616	0	R/W	Target point table	Integer16	0	Point table command 0: Not operate 1 to 255: Execute the specified point table -1: High-speed home position return
11624	0	R	Point demand value	Integer16		Point table demand The currently specified point table No. is returned. While the servo motor is stopped, the value becomes the set value of the Target point table (P11616).
11625	0	R	Point actual value	Integer16		Current point table The completed point table is returned.

20. PROFINET COMMUNICATION

PNU	Sub	Access	Name	Type	Default value	Description
10241 to 10495	0	R/W	Point data	Array [7] Integer32		Position data Unit: pos units
	1	R/W	Speed			Speed Unit: 0.01 r/min or 0.01 mm/s
	2	R/W	Acceleration			Acceleration time constant Unit: ms
	3	R/W	Deceleration			Deceleration time constant Unit: ms
	4	R/W	Dwell			Dwell Unit: ms
	5	R/W	Auxiliary			Auxiliary function Refer to section 9.3.15 (4).
	6	R/W	M code			M code
10819	0	R	Point table error No.	Array [2] Integer32		Point table error number
	1	R	Point table error factor			Point table error factor The error status is indicated when this bit is turned on. Refer to section 9.3.15 (5).
11626	0	R	M code actual value	Unsigned8		Current M code The completed M code of the point table is returned.

(2) Details on the OMS bit of Controlword (pt mode)

Bit	Symbol	Description
4	New set-point	The operation starts from the point table specified with the Target point table (P11616) when the Bit turns on.
5	(reserved)	(Note)
6	(reserved)	
8	HALT	0: Positioning is executed. 1: The servo motor stops according to Halt option code (P24669).
9	(reserved)	(Note)

Note. The values in bit 5, 6 and 9 at reading are undefined. Set "0" when writing.

(3) Details on the OMS bit of Statusword (pt mode)

Bit	Symbol	Description
10	Target reached	0: Halt (Bit 8) = 0: Target position not reached. 0: Halt (Bit 8) = 1: Axis decelerates 1: Halt (Bit 8) = 0: Target position reached. 1: Halt (Bit 8) = 1: Velocity of axis is 0 Judgment condition for Target position reached When the current position and the point table command position vary within Position window (P24679) and this state exceeds Position window time (P24680), this bit will be Target position reached.
12	Set-point acknowledge	0: Positioning completed (wait for next command) 1: Positioning being executed
13	Following error	0: No following error 1: Following error Judgment condition for Following error When the time set with Following error time out (P24678) has elapsed with the number of droop pulses exceeding the set value of the Following error window (P24677), this bit will be "1".

(4) pt mode operation sequence

(a) Automatic individual positioning operation

While the servo motor is stopped under servo-on state, switching on "Controlword bit 4 (New set-point)" starts the automatic positioning operation.

The following shows a timing chart.

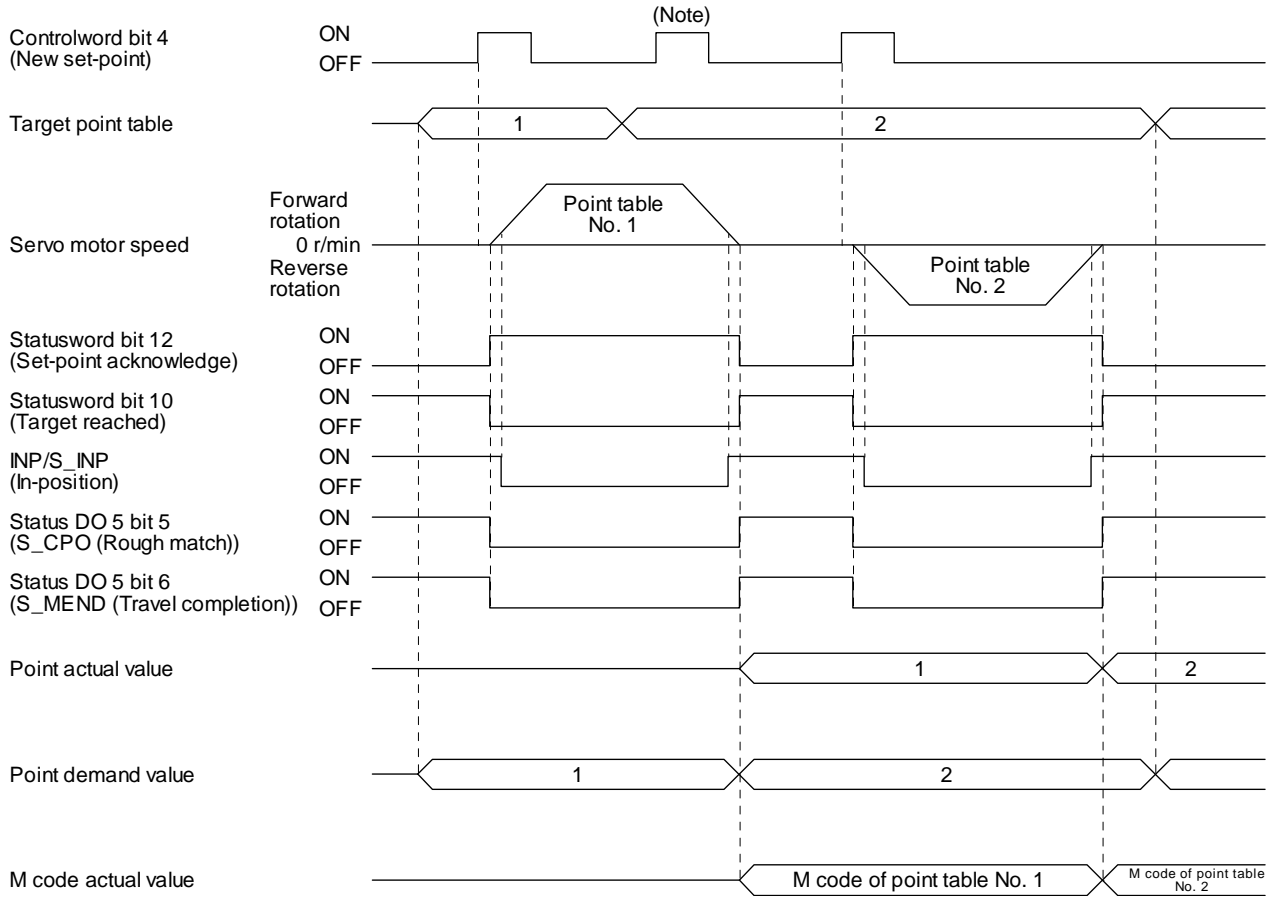

Note. Switching on "Controlword bit 4 (New set-point)" is invalid during the servo motor rotation.

(b) Automatic continuous operation

By merely selecting a point table and switching on "Controlword bit 4 (New set-point)", the operation can be performed in accordance with the point tables having consecutive numbers.

The following shows a timing chart.

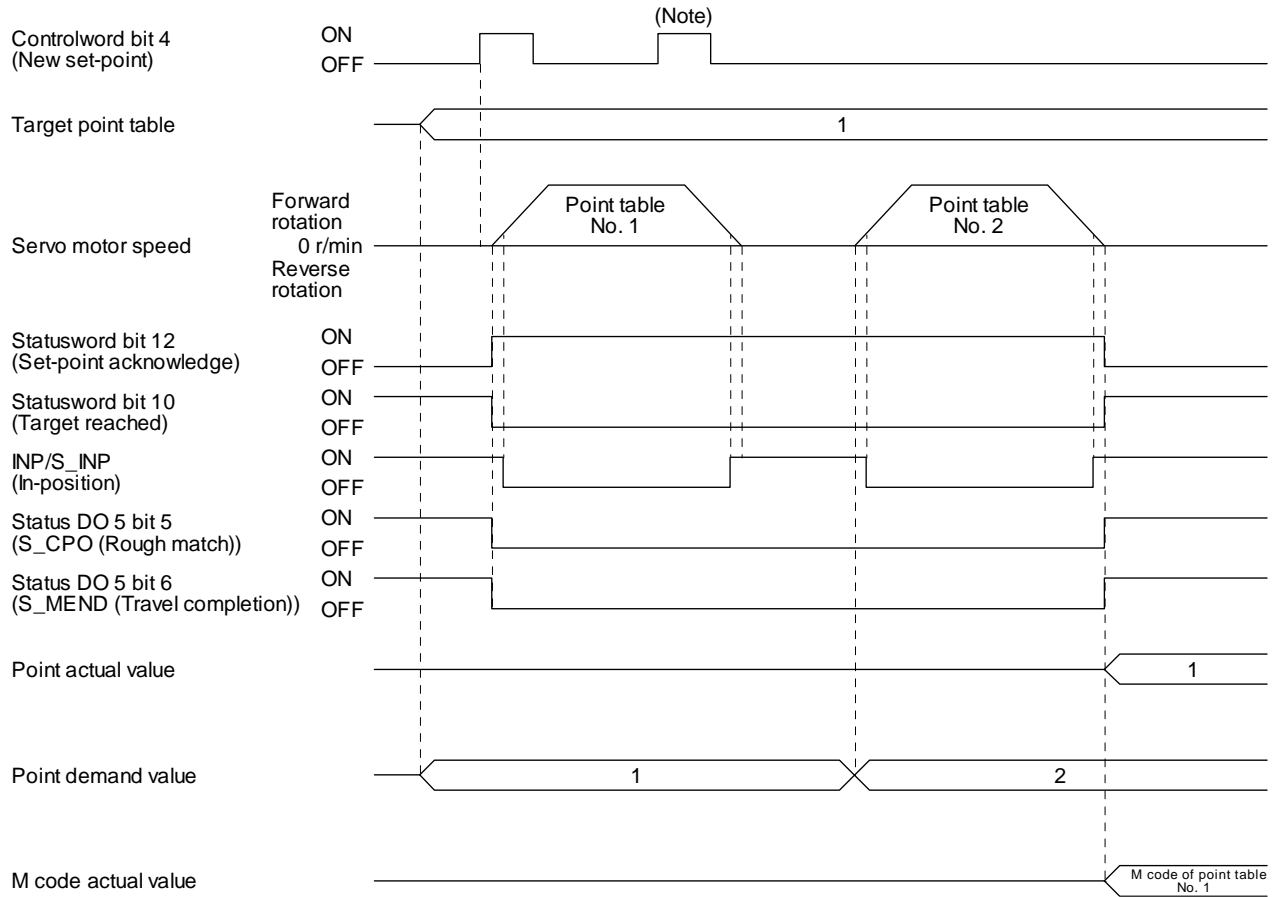

Note. Switching on "Controlword bit 4 (New set-point)" is invalid during the servo motor rotation.

20. PROFINET COMMUNICATION

20.6.8 Indexer mode (idx)

The following shows the functions and related objects of the indexer mode (idx).

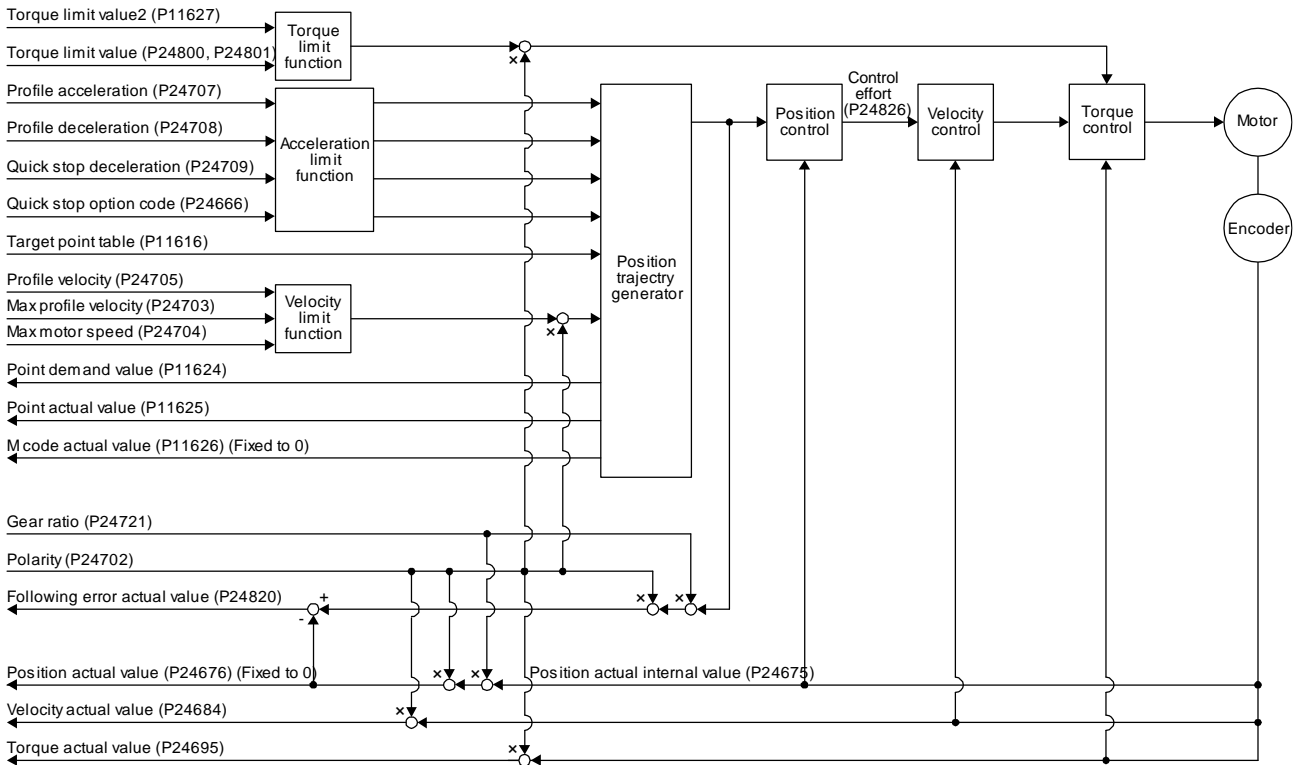

(1) Related object

PNU	Sub	Access	Name	Type	Default value	Description
24699	0	R/W	Min position range limit	Array [2] Integer32		Minimum value of the position range limit In the indexer method, the value becomes "0".
	1	R/W	Max position range limit			Maximum value of the position range limit In the indexer method, the value becomes the set value of [Pr. PT28 Number of stations per rotation] - 1.
24709	0	R/W	Quick stop deceleration	Unsigned32	100	Deceleration at deceleration to a stop by Quick stop Unit: ms
24666	0	R/W	Quick stop option code	Integer16	2	Operation setting for Quick stop Refer to section 8.10.
24675	0	R	Position actual internal value	Integer32		Current position (Enc inc)
24676	0	R	Position actual value	Integer32		Current position (Pos units) In the indexer method, the value is fixed to "0".
24684	0	R	Velocity actual value	Integer32		Current speed Unit: Vel units (0.01 r/min)

20. PROFINET COMMUNICATION

PNU	Sub	Access	Name	Type	Default value	Description
24695	0	R	Torque actual value	Integer32		Current torque Unit: 0.1% (rated torque of 100%)
24703	0	R/W	Max profile velocity	Unsigned32	2000000	maximum speed Unit: Vel units (0.01 r/min)
24704	0	R/W	Max motor speed	Unsigned32		Servo motor maximum speed Unit: r/min
24705	0	R/W	Profile velocity	Unsigned32	10000	Speed after acceleration completed Unit: Vel units (0.01 r/min)
24707	0	R/W	Profile acceleration	Unsigned32		Acceleration at start of movement to target position Unit: ms
24708	0	R/W	Profile deceleration	Unsigned32		Deceleration at arrival at target position Unit: ms
24722	0	R/W	Feed	Array [2] Unsigned32		Travel distance setting Refer to section 9.3.12 (4).
	1	R/W	Shaft revolutions			Number of servo motor shaft revolutions Refer to section 9.3.12 (4).
24820	0	R	Following error actual value	Integer32		Droop pulses (Pos units) (Note)
24826	0	R	Control effort	Integer32		Position control loop output (speed command) Unit: Vel units (0.01 r/min)
24800	0	R/W	Positive torque limit value	Unsigned16	10000	Torque limit value (forward) Unit: 0.1% (rated torque of 100%)
24801	0	R/W	Negative torque limit value	Unsigned16	10000	Torque limit value (reverse) Unit: 0.1% (rated torque of 100%)
24721	0	R/W	Motor revolutions	Array [2] Unsigned32	1	Gear ratio: Number of gear teeth on machine side
	1	R/W	Shaft revolutions		1	Gear ratio: Number of gear teeth on servo motor side
24702	0	R/W	Polarity	Unsigned8	0	Polarity selection Bit 7: Position POL Bit 6: Velocity POL Bit 5: Torque POL (Note) Refer to section 8.5.
24744	0	R/W	SI unit position	Unsigned32	0	SI unit position 00000000h (no unit)
24745	0	R/W	SI unit velocity	Unsigned32	0	SI unit velocity FEB44700h (0.01 r/min)
11616	0	R/W	Target point table	Integer16	0	Point table command Set next station No. 0 to 254: Positioning operation to specified stations
11624	0	R	Point demand value	Integer16		Point table demand The currently specified next station No. is returned. While the servo motor is stopped, the value becomes the set value of the Target point table (2D60h).
11625	0	R	Point actual value	Integer16		Current point table The completed point table is returned. The previous value is held until the operation completes.
11626	0	R	M code actual value	Unsigned8		Current M code In the indexer method, the value is fixed to "0".
11627	0	R/W	Torque limit value 2	Unsigned16	10000	Torque limit value 2 Unit: 0.1% (rated torque of 100%) Set a torque limit value in stop.

Note. In the indexer method, the unit is the command unit [pulse] (a load-side rotation expressed by the number of servo motor resolution pulses).

20. PROFINET COMMUNICATION

(2) Details on the OMS bit of Controlword (idx mode)

Bit	Symbol	Description
4	New set-point	The operation starts toward the point table specified with the Target point table (P11616) when the bit turns on.
5	Direction	0: Station No. decreasing direction 1: Station No. increasing direction
6	Operation mode	0: Rotation direction specifying indexer operation 1: Shortest rotating indexer operation
8	HALT (Not supported)	0: Positioning is executed. 1: The motor stops according to Halt option code (P24669).
9	(reserved)	(Note)

Note. The value in bit 9 at reading is undefined. Set "0" when writing.

(3) Details on the OMS bit of Statusword (idx mode)

Bit	Symbol	Description
10	(reserved)	(Note)
12	Set-point acknowledge	0: Positioning completed (wait for next command) 1: Positioning being executed
13	Following error	0: No following error 1: Following error Judgment condition for Following error When the time set with Following error time out (P24678) has elapsed with the number of droop pulses exceeding the set value of the Following error window (P24677), this bit will be "1".

Note. The value in bit 10 at reading is undefined.

- (4) idx mode operation sequence
 - (a) Rotation direction specifying indexer operation

POINT

● Be sure to perform a home position return. Executing positioning operation without home position return will trigger [AL. 90 Home position return incomplete warning] and "Controlword bit 4 (New set-point)" will be disabled.

The following timing chart shows that an operation is performed at a stop of the station No. 0 when servo-on.

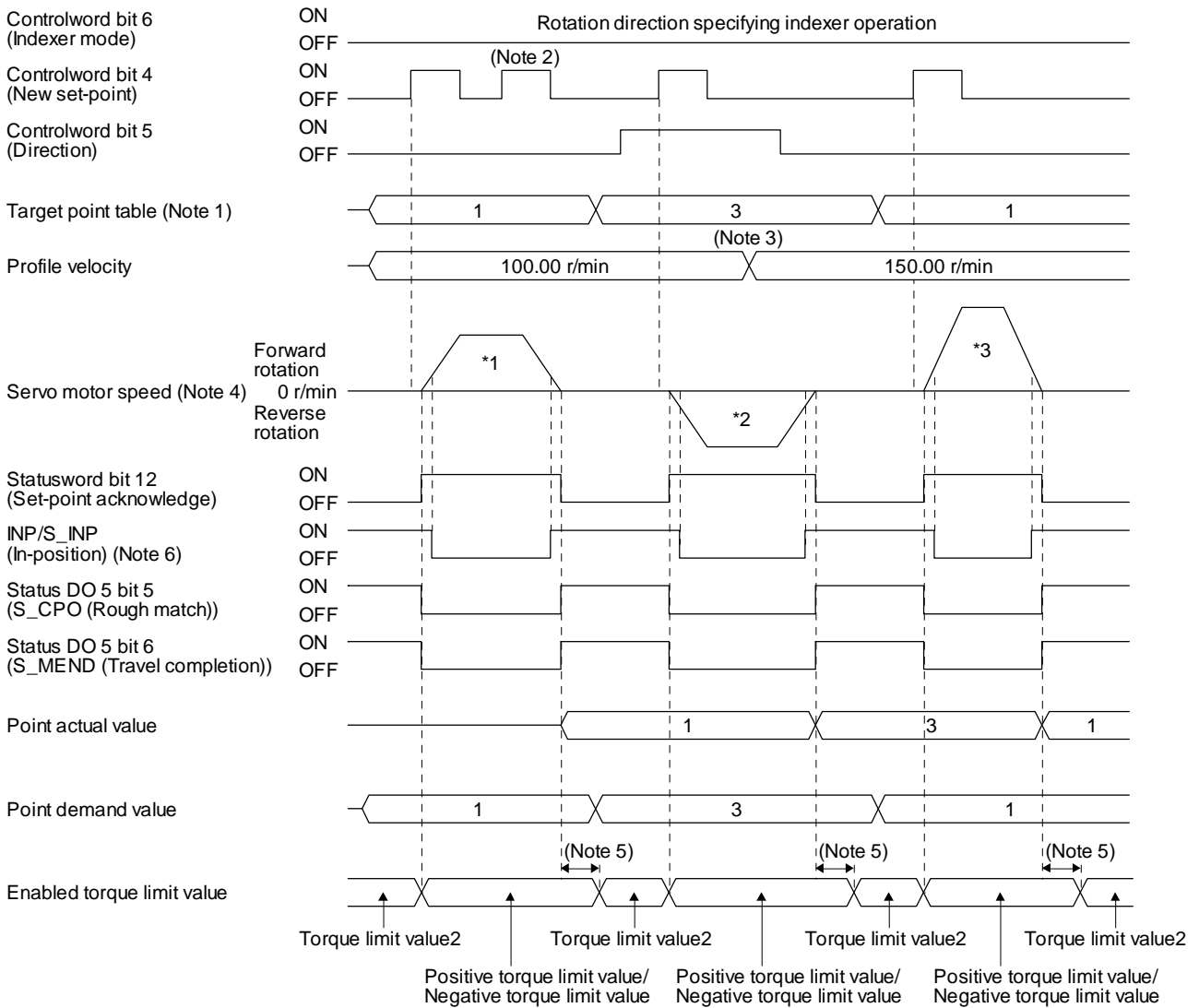

20. PROFINET COMMUNICATION

- Note
1. When the specified station No. exceeds the value set in [Pr. PT28 Number of stations per rotation] -1, the servo motor does not operate.
 2. "Controlword bit 4 (New set-point)" is not received when the rest of command travel distance is other than "0".
 3. Switching "Profile velocity" during the servo motor rotation does not enable this.
 4. The following shows the operations to be executed.

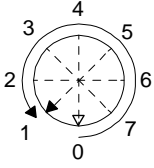
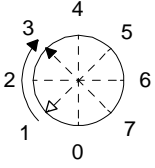
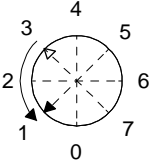
Operation	*1	*2	*3
Station	No. 1	No. 3	No. 1
Servo motor speed	100.00 r/min	100.00 r/min	150.00 r/min
Positioning			

5. A delay time can be set with [Pr. PT39].
6. After power-on, this turns on if the value is within the in-position range of the corresponding station position.

(b) Shortest rotating indexer operation

POINT
<ul style="list-style-type: none"> ● Be sure to perform a home position return. Executing positioning operation without home position return will trigger [AL. 90 Home position return incomplete warning] and "Controlword bit 4 (New set-point)" will be disabled. ● When travel distances to a target station position from CCW and from CW are the same, the shaft will rotate to the station No. increasing direction.

This disables "Controlword bit 5 (Direction)". The following timing chart shows that an operation is performed at a stop of the station No. 0 when servo-on.

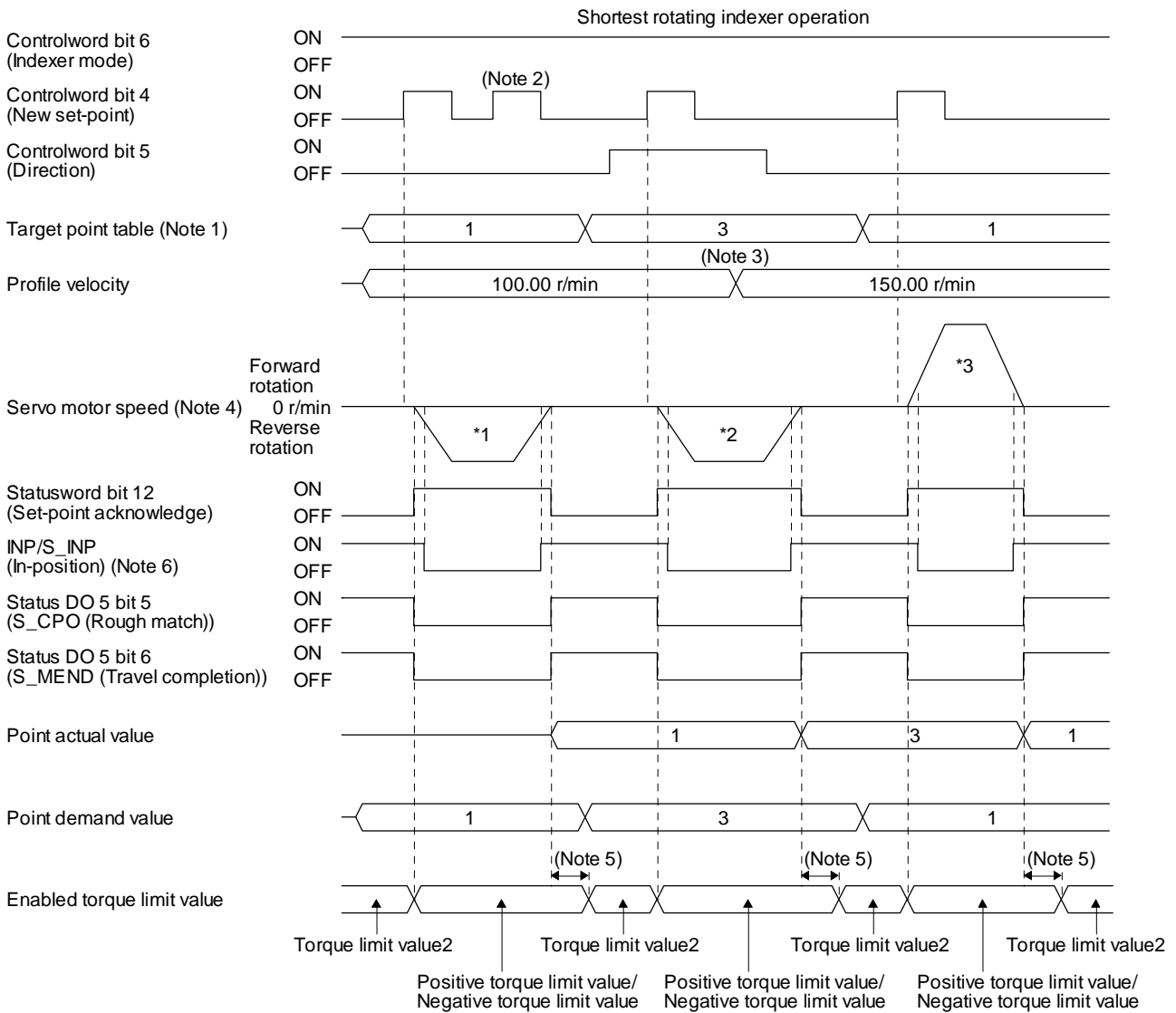

20. PROFINET COMMUNICATION

- Note
1. When the specified station No. exceeds the value set in [Pr. PT28 Number of stations per rotation] -1, the servo motor does not operate.
 2. "Controlword bit 4 (New set-point)" is not received when the rest of command travel distance is other than "0".
 3. Switching "Profile velocity" during the servo motor rotation does not enable this.
 4. The following shows the operations to be executed.

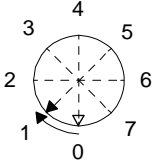
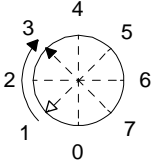
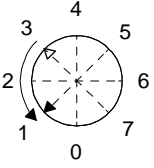
Operation	*1	*2	*3
Station	No. 1	No. 3	No. 1
Servo motor speed	100.00 r/min	100.00 r/min	150.00 r/min
Positioning			

5. A delay time can be set with [Pr. PT39].
6. After power-on, this turns on if the value is within the in-position range of the corresponding station position.

20. PROFINET COMMUNICATION

20.6.9 Jog mode (jg)

The following shows the function and related objects of the Jog mode (jg).

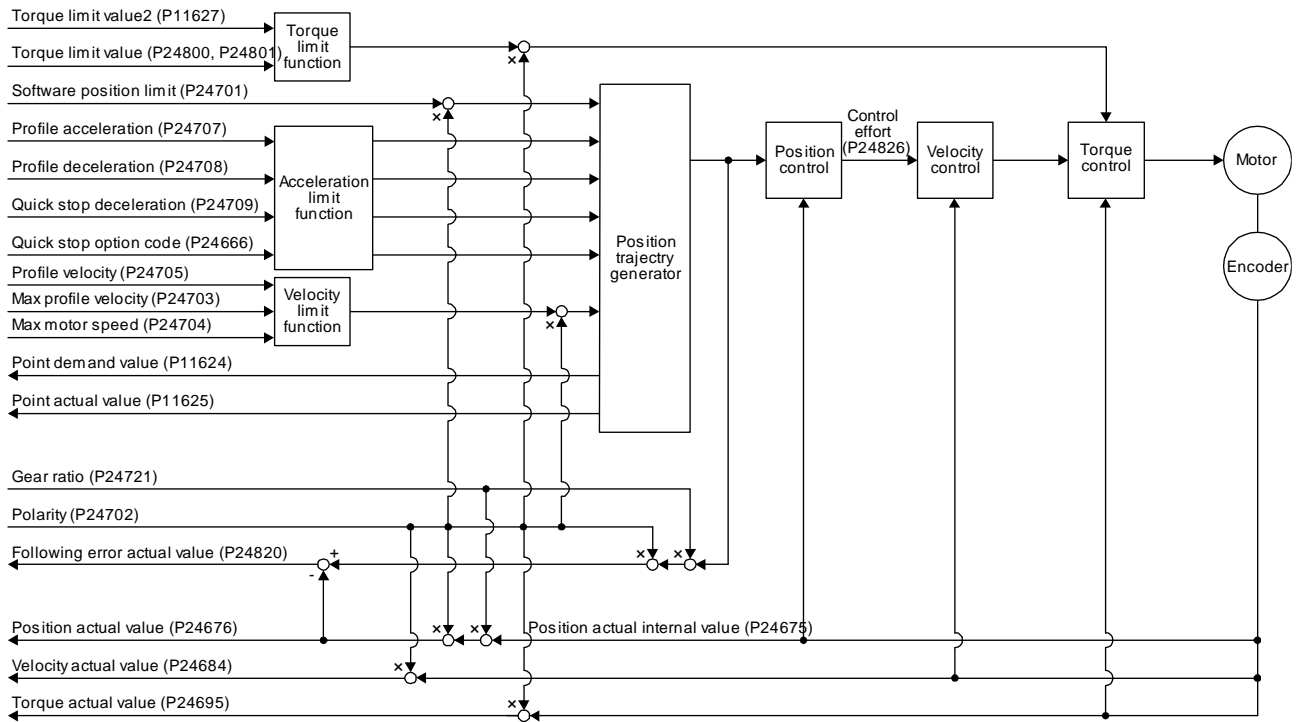

(1) Related object

PNU	Sub	Access	Name	Type	Default value	Description
24699	0	R/W	Min position range limit	Array [2] Integer32		Minimum value of the position range limit The value is automatically set according to the setting of "Position data unit" of [Pr. PT01]. mm/inch/pulse: -2147483648 In the indexer method, the value becomes "0".
	1	R/W	Max position range limit			Maximum value of the position range limit The value is automatically set according to the setting of "Position data unit" of [Pr. PT01]. mm/inch/pulse: 2147483647 In the indexer method, the set value in [Pr. PT28] -1 will be set.
24701	0	R/W	Min position limit	Array [2] Integer32	0	Minimum position address (Pos units) This cannot be used in the indexer method.
	1	R/W	Max position limit		0	Maximum position address (Pos units) This cannot be used in the indexer method.
24703	0	R/W	Max profile velocity	Unsigned32	2000000	maximum speed Unit: Vel units (0.01 r/min or 0.01 mm/s)
24704	0	R/W	Max motor speed	Unsigned32		Servo motor maximum speed Unit: r/min
24705	0	R/W	Profile velocity	Unsigned32	10000	Speed after acceleration completed Unit: Vel units (0.01 r/min or 0.01 mm/s)

20. PROFINET COMMUNICATION

PNU	Sub	Access	Name	Type	Default value	Description
24707	0	R/W	Profile acceleration	Unsigned32	0	Acceleration at start of movement to target position Unit: ms
24708	0	R/W	Profile deceleration	Unsigned32	0	Deceleration at arrival at target position Unit: ms
24709	0	R/W	Quick stop deceleration	Unsigned32	100	Deceleration at deceleration to a stop by Quick stop Unit: ms
24666	0	R/W	Quick stop option code	Integer16	2	Operation setting for Quick stop Refer to section 8.10.
24675	0	R	Position actual internal value	Integer32		Current position (Enc inc)
24676	0	R	Position actual value	Integer32		Current position (Pos units) In the indexer method, the value is fixed to "0".
24684	0	R	Velocity actual value	Integer32		Current speed Unit: Vel units (0.01 r/min or 0.01 mm/s) In the indexer method, this is available only in 0.01 r/min.
24695	0	R	Torque actual value	Integer16		Current torque Unit: 0.1% (rated torque of 100%)
24722	0	R/W	Feed	Array [2] Unsigned32		Travel distance setting Refer to section 9.3.12 (4).
	1	R/W	Shaft revolutions		1	Number of servo motor shaft revolutions Refer to section 9.3.12 (4).
24820	0	R	Following error actual value	Integer32		Droop pulses (Pos units) (Note)
24826	0	R	Control effort	Integer32		Position control loop output (speed command) Unit: Vel units (0.01 r/min or 0.01 mm/s)
24800	0	R/W	Positive torque limit value	Unsigned16	10000	Torque limit value (forward) Unit: 0.1% (rated torque of 100%)
24801	0	R/W	Negative torque limit value	Unsigned16	10000	Torque limit value (reverse) Unit: 0.1% (rated torque of 100%)
24721	0	R/W	Motor revolutions	Array [2] Unsigned32	1	Number of revolutions of the servo motor shaft (numerator) In the indexer method, this means the number of gear teeth on machine side.
	1	R/W	Shaft revolutions		1	Number of revolutions of the drive shaft (denominator) In the indexer method, this means the number of gear teeth on servo motor side.
24702	0	R/W	Polarity	Unsigned8	0	Polarity selection Bit 7: Position POL Bit 6: Velocity POL Bit 5: Torque POL (Note) Refer to section 8.5.
24744	0	R/W	SI unit position	Unsigned32	0	SI unit position The value is automatically set according to the setting of "Position data unit" of [Pr. PT01]. Refer to section 9.3.12 (5).
24745	0	R/W	SI unit velocity	Unsigned32	0	SI unit velocity 0.01 r/min or 0.01 mm/s FB010300h (0.01 mm/s) FEB44700h (0.01 r/min) In the indexer method, this is available only in 0.01 r/min.

20. PROFINET COMMUNICATION

PNU	Sub	Access	Name	Type	Default value	Description
11624	0	R	Point demand value	Integer16		Point table demand In the point table method, "0" is returned. In the indexer method, the next station No. is set.
11625	0	R	Point actual value	Integer16		Current point table In the point table method, the previous value is held. In the indexer method, the station No. at which the servo motor has stopped is set. However, the previous value is held when S_MEND is off.
11627	0	R/W	Torque limit value 2	Unsigned16	10000	Torque limit value 2 Unit: 0.1% (rated torque of 100%) A torque limit value in stop is set. This can be used only in the indexer method.

Note. In the indexer method, the unit is the command unit [pulse] (a load-side rotation expressed by the number of servo motor resolution pulses).

(2) Details on the OMS bit of Controlword (jg mode)

Bit	Symbol	Description
4	Rotation start	0: Stop the motor 1: Start the motor
5	Direction	0: Forward rotation (address increase) 1: Reverse rotation (address decrease)
6	(reserved)	(Note)
8	HALT	0: Positioning is executed. 1: The servo motor stops according to Halt option code (P24669). In the indexer method, this bit is disabled.
9	(reserved)	(Note)

Note. The values in bit 6 and 9 at reading are undefined.

(3) Details on the OMS bit of Statusword (jg mode)

Bit	Symbol	Description
10	Target reached	0 (Halt (Bit 8) = 0) : Target position not reached. 0 (Halt (Bit 8) = 1) : Axis decelerates 1 (Halt (Bit 8) = 0) : Target position reached. 1 (Halt (Bit 8) = 1) : Velocity of axis is 0 Judgment condition for Target position reached If the error between Position actual value (P24676) and Target position (P24698) has stayed within Position window (P24679) for Position window time (P24680) or more, Target position reached is stored.
12	(reserved)	(Note)
13	Following error	0: No following error 1: Following error Judgment condition for Following error When the time set with Following error time out (P24678) has elapsed with the number of droop pulses exceeding the set value of the Following error window (P24677), this bit will be "1".

Note. The value in bit 12 at reading is undefined.

- (4) jg mode operation sequence in the point table method
 - (a) When operating at a constant speed

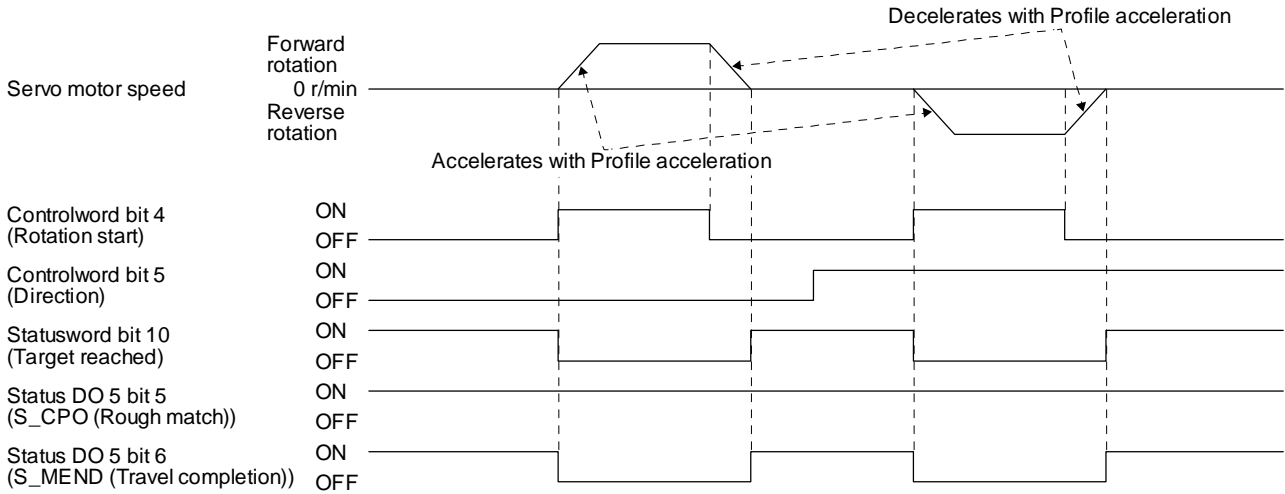

- (b) When changing the speed during operation

You can change the servo motor speed by changing the "Profile velocity" during operation. However, the servo motor speed cannot be changed during deceleration. The acceleration time constant and the deceleration time constant can be changed only while the servo motor is stopped.

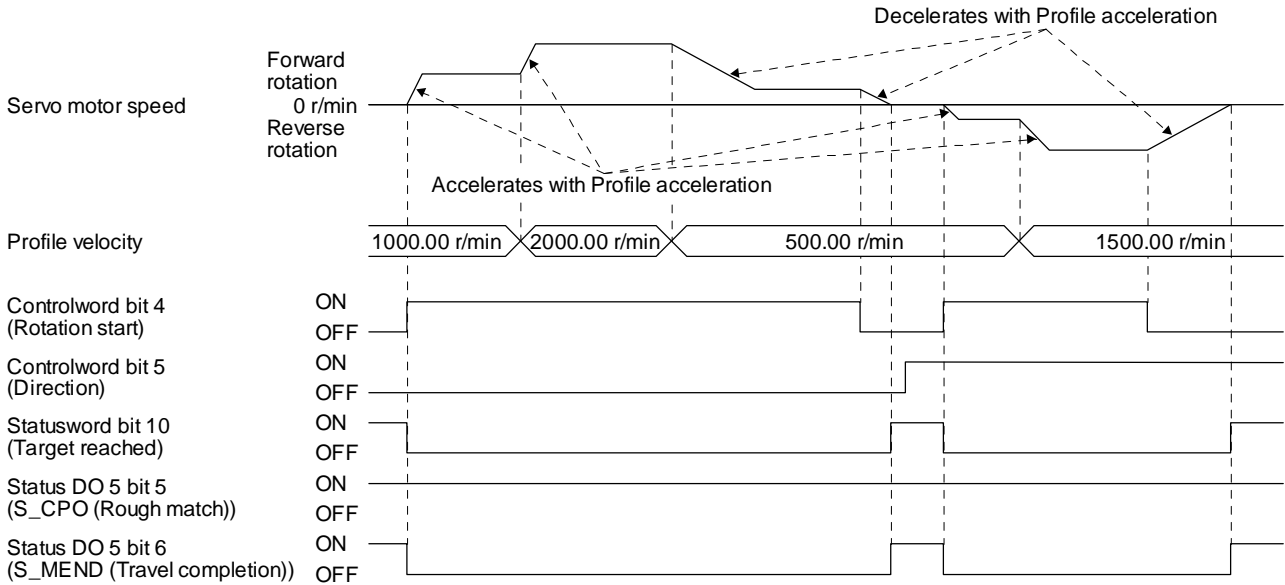

20. PROFINET COMMUNICATION

(5) jg mode operation sequence in the indexer method

(a) Station JOG operation

The following timing chart shows that a station JOG operation is performed at a stop of the station No. 0 when servo-on.

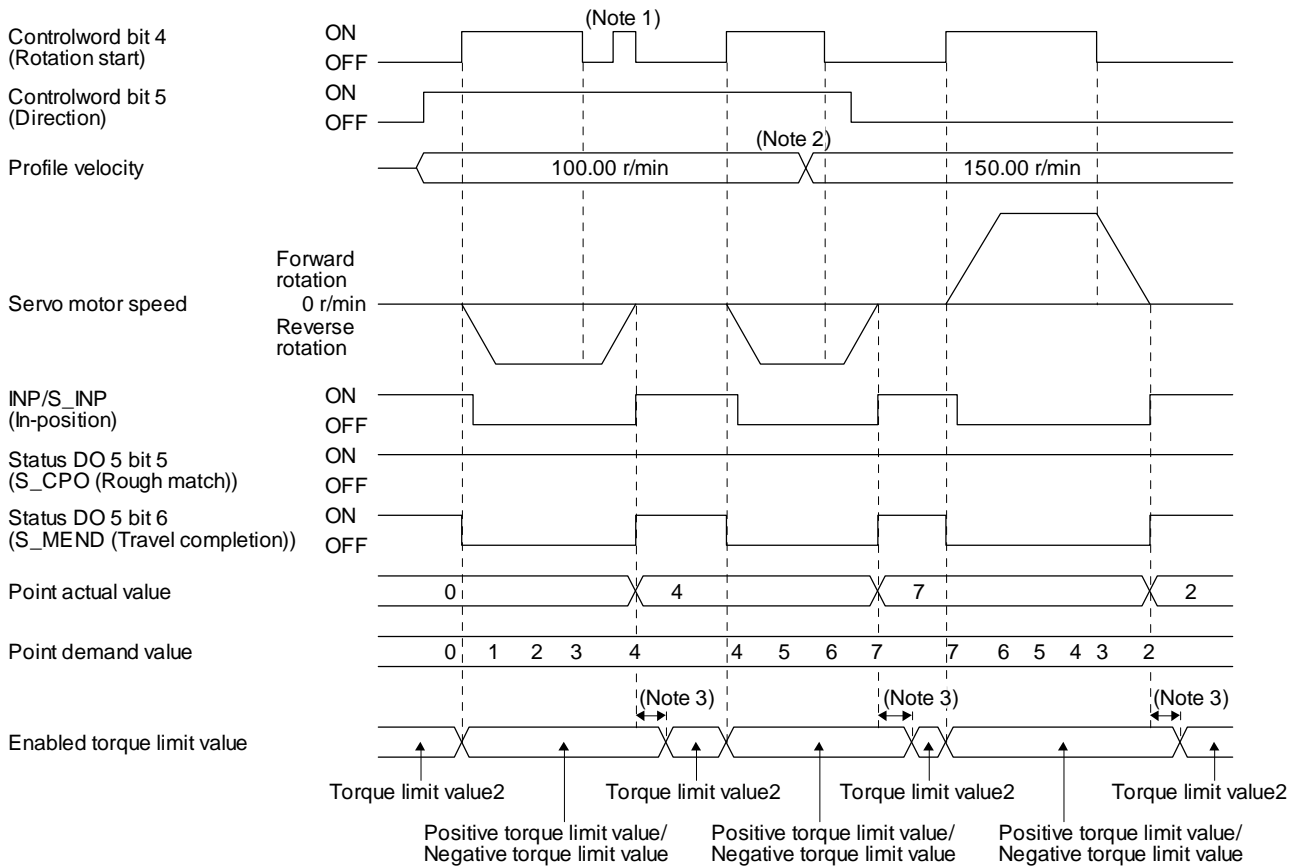

Note 1	"Controlword bit 4 (Rotation start)" is not received when the rest of command travel distance is other than "0".
2	Switching "Profile velocity" during the servo motor rotation does not enable this.
3	A delay time can be set with [Pr. PT39].

(b) JOG operation

The following timing chart shows that a JOG operation is performed at a stop of the station No. 0 when servo-on.

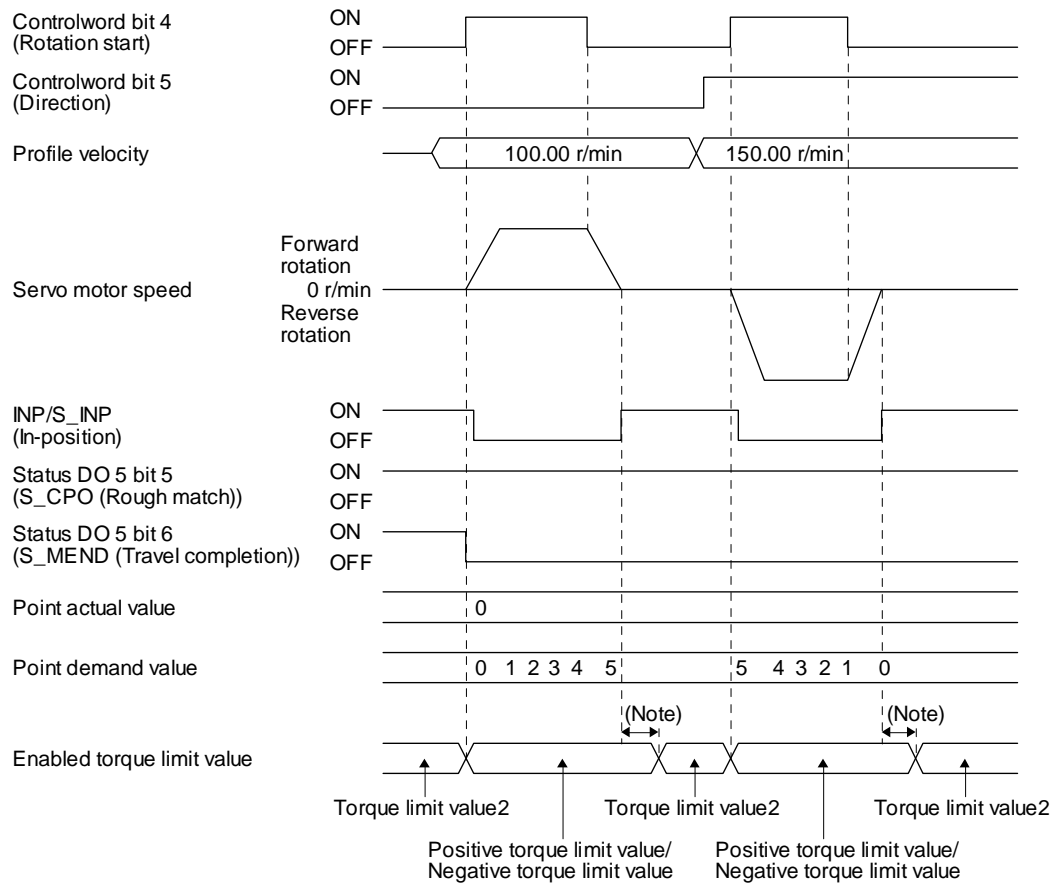

Note.	A delay time can be set with [Pr. PT39].
-------	--

20. PROFINET COMMUNICATION

20.7 WEB SERVER

You can configure various settings and monitor the driver in a web browser with the web server function of _ (PROFINET).

When you access the PROFINET network card with web browser, the following will be displayed. (The example shows Card parameter and Network configuration.)

To save each setting set from the Card parameter page to EEPROM, Store Parameters are required. (Refer to section 9.1.)

Input the parameter setting values in hexadecimal.

MODULE	Page 1 of 79			← 1 →	Refresh
Overview	#	Name	Value		
Parameters	4112	Store parameters	0: 1		Set
			1: 1		Set
			2: 1		Set
NETWORK					
Status					
Configuration	8193	PA01	4096		Set
SERVICES	8194	PA02	0		Set
SMTP	8195	PA03	0		Set
	8196	PA04	8448		Set
	8197	PA05	10000		Set
	8198	PA06	1		Set
	8199	PA07	1		Set
	8200	PA08	1		Set
	8201	PA09	16		Set

MODULE	IP Configuration	
Overview	DHCP	Disabled ▾
Parameters	IP Address	0.0.0.0
NETWORK	Subnet Mask	0.0.0.0
Status	Gateway Address	0.0.0.0
Configuration	Host Name	
SERVICES	Domain name	
SMTP	DNS Server #1	0.0.0.0
	DNS Server #2	0.0.0.0
	Save settings	

20. PROFINET COMMUNICATION

20.8 MANUFACTURER FUNCTIONS

20.8.1 PROFIdrive parameters for status monitor

PNU	Sub	Access	Name	Type	Default value	Description
11009	0	R/W	Monitor 1 Cumulative feedback pulses	Integer32		Cumulative feedback pulses (Unit: pulse) Cleared by writing "0000 1EA5h".
11010	0	R	Monitor 2 Servo motor speed	Integer32		Servo motor speed (Unit: r/min)
11011	0	R	Monitor 3 Droop pulse	Integer32		Droop pulses (Unit: pulse)
11012	0	R	Monitor 4 Cumulative command pulses	Integer32		Cumulative command pulses (Unit: pulse)
11013	0	R	Monitor 5 Command pulse frequency	Integer32		Command pulse frequency (Unit: kpulse/s)
11016	0	R	Monitor 8 Regenerative load ratio	Unsigned16		Regenerative load ratio (Unit: %)
11017	0	R	Monitor 9 Effective load ratio	Unsigned16		Effective load ratio (Unit: %)
11018	0	R	Monitor 10 Peak load ratio	Unsigned16		Peak load ratio (Unit: %)
11019	0	R	Monitor 11 Instantaneous torque	Integer16		Instantaneous torque (Unit: %)
11020	0	R	Monitor 12 Within one-revolution position	Integer32		Position within one-revolution (Unit: pulse)
11021	0	R	Monitor 13 ABS counter	Integer32		ABS counter (Unit: rev)
11022	0	R	Monitor 14 Load to motor inertia ratio	Unsigned16		Load to motor inertia ratio (Unit: 0.01 times)
11023	0	R	Monitor 15 Bus voltage	Unsigned16		Bus voltage (Unit: V)
11024	0	R	Monitor 16 Load side encoder cumulative feedback pulses	Integer32		Load-side cumulative feedback pulses (Unit: pulse)
11025	0	R	Monitor 17 Load side encoder droop pulses	Integer32		Load-side encoder droop pulses (Unit: pulse)
11026	0	R	Monitor 18 Load side encoder information 1	Integer32		Load-side encoder information 1 (Unit: pulse)
11027	0	R	Monitor 19 Load side encoder information 2	Integer32		Load-side encoder information 2 (Unit: rev)
11031	0	R	Monitor 23 Temperature of motor thermistor	Integer16		Servo motor thermistor temperature (Unit: °C)
11032	0	R	Monitor 24 Motor side cumulative F/B pulses (BeforeGear)	Integer32		Servo motor-side cumulative feedback pulses (before gear) (Unit: pulse)
11033	0	R	Monitor 25 Electrical angle	Integer32		Electrical angle (Unit: pulse)
11043	0	R	Monitor 35 Motor/load side position deviation	Integer32		Servo motor-side/load-side position deviation (Unit: pulse)

20. PROFINET COMMUNICATION

PNU	Sub	Access	Name	Type	Default value	Description
11044	0	R	Monitor 36 Motor/load side speed deviation	Integer32		Servo motor-side/load-side speed deviation (Unit: r/min)
11045	0	R	Monitor 37 Internal temperature of encoder	Integer16		Internal temperature of encoder (Unit: °C)
11046	0	R	Monitor 38 Settling time	Integer16		Settling time (Unit: ms)
11047	0	R	Monitor 39 Oscillation detection frequency	Integer16		Oscillation detection frequency (Unit: Hz)
11048	0	R	Monitor 40 Number of tough drive operations	Unsigned32		Number of tough drive operations (Unit: time)
11053	0	R	Monitor 45 Unit power consumption	Integer16		Unit power consumption (Unit: W)
11054	0	R	Monitor 46 Unit total power consumption	Integer32		Unit total power consumption (Unit: Wh)
11055	0	R	Monitor 47 Current position	Integer32		Current position (Note 2) (Unit: pos units)
11056	0	R	Monitor 48 Command position	Integer32		Command position (Note 2) (Unit: pos units)
11057	0	R	Monitor 49 Remaining command distance	Integer32		Command remaining distance (Note 3) (Unit: pos units)
11058	0	R	Monitor 50 Point table No./Program No./Station position No.	Integer16		Point table No./station position No. (Note 3) (Unit: none)

2	In the indexer method, the value is fixed to "0".
3	This is available in the point table method and the indexer method. In the other control modes, the value is fixed to "0".

20. PROFINET COMMUNICATION

20.8.2 Stroke end

When LSP (Forward rotation stroke end) or LSN (Reverse rotation stroke end) is turned off, a slow stop is performed by either of the following stop methods.

Operation status		Remark
During rotation at constant speed	During deceleration to a stop	
<p>— No S-pattern acceleration/ deceleration - - - With S-pattern acceleration/ deceleration</p> <p>Servo motor speed</p> <p>0 r/min (0 mm/s)</p> <p>Part of droop pulses</p> <p>LSP or LSN</p> <p>ON OFF</p>	<p>— No S-pattern acceleration/ deceleration - - - With S-pattern acceleration/ deceleration</p> <p>Servo motor speed</p> <p>0 r/min (0 mm/s)</p> <p>Part of droop pulses</p> <p>LSP or LSN</p> <p>ON OFF</p>	<p>Travels for the droop pulse portion and stops the servo motor.</p> <p>A difference will be generated between the command position and the current position.</p> <p>Perform a home position return again.</p>

Perform a return as follows when the stroke end is detected.

Mode	Return method
Profile position mode (pp)	Input the position command of the direction opposite to the limit to Target position (P24698).
Profile velocity mode (pv)	Input the speed command of the direction opposite to the limit to Target velocity (P24831). When Standard telegram1 is selected, input it to Speed setpoint A.
Point table mode (pt)	Perform operation opposite to the limit with the JOG operation. After moving the machine to the range of the limit, execute a home position return.
Jog mode (jg)	Perform operation opposite to the limit with the Jog mode.
Indexer mode (idx)	Perform operation opposite to the limit with the JOG operation.

20. PROFINET COMMUNICATION

20. 8. 3 Software limit

Specify the upper and lower limits of the command position and current position. If a command position exceeding the limit position is specified, the command position is clamped at the limit position. Specify a relative position from the machine home point (position address = 0) as the limit position.

This function is enabled when the home position is not erased in the profile position mode (pp). While the clamp processing is being performed with the command position exceeding the limit value, [AL. 98 Software limit warning] occurs and not cleared. When the position command of the direction opposite to reached Software position limit is given, the operation can be restarted.

Table 8.3 Definition of Software position limit

PNU	Sub	Access	Name	Type	Default value	Description
24701	0	R/W	Min position limit (Note)	Array [2] Integer32	0	Specify a relative position from the machine home point (position address = 0) as the minimum value of the command position and current position. When the value falls below the minimum value, it is clamped and processed as the minimum value.
	1	R/W	Max position limit (Note)		0	Specify a relative position from the machine home point (position address = 0) as the maximum value of the command position and current position. When the value exceeds the maximum value, it is clamped and processed as the maximum value.

Note. When the set value of Min position limit is equal to or greater than the set value of Max position limit, the function of Software position limit is disabled.

Software position limit (P24701) can be saved in EEPROM. The data saved in EEPROM is reflected to Software position limit (P24701) at power-on.

20. 8. 4 Torque limit

Generated torque can be limited with the values of Positive torque limit value (P24800) and Negative torque limit value (P24801). When "0" is set, torque is not generated.

The polarity of the torque limit value varies depending on the setting of bit 5 Torque polarity of Polarity (P24702).

Table 8.4 Definition of Positive/Negative torque limit value

PNU	Sub	Access	Name	Type	Default value	Description
24800	0	R/W	Positive torque limit value	Unsigned16	10000	[Pr. PA11 Forward rotation torque limit] Torque limit value in CCW power running/CW regeneration Unit: 0.1% (rated torque of 100%) Range: 0 to 10000 Changing polarity of the torque limit value will change the reading/writing parameter from [Pr. PA11] to [Pr. PA12]. When the parameter is changed, the torque limit value will be at CCW direction regeneration/CW direction power running.
24801	0	R/W	Negative torque limit value	Unsigned16	10000	[Pr. PA12 Reverse rotation torque limit] Torque limit value in CW power running/CCW regeneration Unit: 0.1% (rated torque of 100%) Range: 0 to 10000 Changing polarity of the torque limit value will change the reading/writing parameter from [Pr. PA12] to [Pr. PA11]. When the parameter is changed, the torque limit value will be at CCW direction power running/CW direction regeneration.

20. PROFINET COMMUNICATION

20.8.5 Polarity

The rotation direction of a servo motor to position commands, speed commands, and torque commands can be set with Polarity (P24702). For the Polarity setting to position commands and speed commands, use [Pr. PA14]. For the Polarity setting to torque commands, use [Pr. PA14] and [Pr. PC29] (x _ _ _).

A change in the setting of Polarity is not applied immediately. Refer to section 8.14.1 for the procedure of enabling parameters.

(1) Bit definition

7	6	5	4	3	2	1	0
Position POL	Speed POL	Torque POL	Reserve				

The polarity is reversed when this bit is turned on.

(2) Target parameter

The following shows objects whose polarity is reversed according to the setting of Polarity.

No.	Object	Remark
1	Target position (P24698)	
2	Target velocity (P24831)	
3	Target torque (P24689)	
5	Position actual value (P24676)	
6	Velocity demand value (P24683)	Whether to reverse the polarity using Polarity can be switched with [Pr. PC76] (x _ _ _). [Pr. PC76] = _ 0 _ _ (Automatic setting): Automatically set depending on the type of the network in use. [Pr. PC76] = _ 1 _ _ (POL setting enabled): The polarity is reversed using Polarity. [Pr. PC76] = _ 2 _ _ (POL setting disabled): The polarity is not reversed using Polarity.
7	Velocity actual value (P24684)	
8	Torque demand (P24692)	
9	Torque actual value (P24695)	
10	Positive torque limit value (P24800)	The corresponding parameters are changed according to the settings of [Pr. PA14] and [Pr. PC29] (x _ _ _). [Pr. PA14] = 0, [Pr. PC29] = 1 _ _ _ : Written to [Pr. PA11] (TLP). [Pr. PA14] = 1, [Pr. PC29] = 1 _ _ _ : Written to [Pr. PA11] (TLP). [Pr. PA14] = 0, [Pr. PC29] = 0 _ _ _ : Written to [Pr. PA11] (TLP). [Pr. PA14] = 1, [Pr. PC29] = 0 _ _ _ : Written to [Pr. PA12] (TLN).
11	Negative torque limit value (P24801)	The corresponding parameters are changed according to the settings of [Pr. PA14] and [Pr. PC29] (x _ _ _). [Pr. PA14] = 0, [Pr. PC29] = 1 _ _ _ : Written to [Pr. PA12] (TLN). [Pr. PA14] = 1, [Pr. PC29] = 1 _ _ _ : Written to [Pr. PA12] (TLN). [Pr. PA14] = 0, [Pr. PC29] = 0 _ _ _ : Written to [Pr. PA12] (TLN). [Pr. PA14] = 1, [Pr. PC29] = 0 _ _ _ : Written to [Pr. PA11] (TLP).
12	Digital inputs (P24829)	The corresponding status is changed according to the setting of [Pr. PA14] as follows. [Pr. PA14] = 0: The status of LSN (Reverse rotation stroke end) is applied to Negative limit switch (bit 0). The status of LSP (Forward rotation stroke end) is applied to Positive limit switch (bit 1). [Pr. PA14] = 1: The status of LSP (Reverse rotation stroke end) is applied to Negative limit switch (bit 0). The status of LSN (reverse rotation stroke end) is applied to Positive limit switch (bit 1).
13	Speed setpoint A	
14	Speed actual value A	

20. PROFINET COMMUNICATION

20.8.6 Touch probe

POINT
● Touch probe cannot be used in the indexer method.

The touch probe function that executes current position latch by sensor input can be used.

With this function, the position feedback of the rising edge and falling edge of TPR1 (touch probe 1) and TPR2 (touch probe 2) or the position feedback of the encoder zero point passing can be memorized and stored into each object of P24762 to P24765 according to the conditions specified in Touch probe function (P24760).

The following shows the touch probe detection resolution. Enabling the high precision touch probe will disable the encoder output pulses.

		Touch probe1	Touch probe2
Input terminal		TPR1	TPR2
Encoder resolution	[Pr. PD37] = ___ 0 (Selection of high-precision touch probe is disabled)	55 μs	55 μs
	[Pr. PD37] = ___ 1 (Selection of high-precision touch probe is enabled)	55 μs	Rising: 2 μs Falling: 55 μs

(1) Related PROFIdrive parameters

PNU	Sub	Access	Name	Type	Default value	Description
24760	0	R/W	Touch probe function	Unsigned16		Settings such as enabling/disabling of the touch probe function and trigger conditions
24761	0	R	Touch probe status	Unsigned16	0	Status information of the touch probe function
24762	0	R	Touch probe pos1 pos value	Integer32	0	Shows the rising edge position of Touch probe 1. (Pos units)
24763	0	R	Touch probe pos1 neg value	Integer32	0	Shows the falling edge position of Touch probe 1. (Pos units)
24764	0	R	Touch probe pos2 pos value	Integer32	0	Shows the rising edge position of Touch probe 2. (Pos units)
24765	0	R	Touch probe pos2 neg value	Integer32	0	Shows the falling edge position of Touch probe 2. (Pos units)

(2) Details of Touch probe function (P24760)

Bit	Definition
0	0: Touch probe 1 disabled 1: Touch probe 1 enabled
1	0: Single trigger mode 1: Continuous trigger mode
2	0: Set input of touch probe 1 as a trigger 1: Set 0 point of the encoder as a trigger
3	(Reserved)
4	0: Stop sampling at the rising edge of touch probe 1 1: Start sampling at the rising edge of touch probe 1 When the input of touch probe 1 is set as a trigger (Bit 2 = 0), the position feedback latched at rising edge of touch probe 1 is stored in Touch probe pos1 pos value (P24762). When the encoder zero point is set as a trigger (Bit 2 = 1), the position feedback of when the encoder zero point was passed through is stored in Touch probe pos1 pos value (P24762).
5	0: Stop sampling at the falling edge of touch probe 1 1: Start sampling at the falling edge of touch probe 1 When the input of touch probe 1 is set as a trigger (Bit 2 = 0), the position feedback latched at falling edge of touch probe 1 is stored in Touch probe pos1 neg value (P24763). When the encoder zero point is set as a trigger (Bit 2 = 1), the position feedback of when the encoder zero point was passed through is stored in Touch probe pos1 neg value (P24763).
6	(Reserved)
7	(Reserved)
8	0: Touch probe 2 disabled 1: Touch probe 2 enabled
9	0: Single trigger mode 1: Continuous trigger mode
10	0: Set input of touch probe 2 as a trigger 1: Set 0 point of the encoder as a trigger
11	(Reserved)
12	0: Stop sampling at the rising edge of touch probe 2 1: Start sampling at the rising edge of touch probe 2 When the input of touch probe 2 is set as a trigger (Bit 10 = 0), the position feedback latched at rising edge of touch probe 2 is stored in Touch probe pos2 pos value (P24764). When the encoder zero point is set as a trigger (Bit 10 = 1), the position feedback of when the encoder zero point was passed through is stored in Touch probe pos2 pos value (P24764).
13	0: Stop sampling at the falling edge of touch probe 2 1: Start sampling at the falling edge of touch probe 2 When the input of touch probe 2 is set as a trigger (Bit 10 = 0), the position feedback latched at falling edge of touch probe 2 is stored in Touch probe pos2 neg value (P24765). When the encoder zero point is set as a trigger (Bit 10 = 1), the position feedback of when the encoder zero point was passed through is stored in Touch probe pos2 neg value (P24765).
14	(Reserved)
15	(Reserved)

20. PROFINET COMMUNICATION

(3) Details of Touch probe status (P24761)

Bit	Definition
0	0: Touch probe 1 disabled 1: Touch probe 1 enabled
1	0: The rising edge position of touch probe 1 has not been stored. 1: The rising edge position of touch probe 1 has been stored. When the position feedback is stored in Touch probe pos1 pos value (P24762), "1" will be set. Setting Bit 4 of Touch probe function (P24760) to "0" will clear the value to "0".
2	0: The falling edge position of touch probe 1 has not been stored. 1: The falling edge position of touch probe 1 has been stored. When the position feedback is stored in Touch probe neg1 neg value (P24763), "1" will be set. Setting Bit 5 of Touch probe function (P24760) to "0" will clear the value to "0".
3-7	(Reserved)
8	0: Touch probe 2 disabled 1: Touch probe 2 enabled
9	0: The rising edge position of touch probe 2 has not been stored. 1: The rising edge position of touch probe 2 has been stored. When the position feedback is stored in Touch probe pos2 pos value (P24764), "1" will be set. Setting Bit 12 of Touch probe function (P24760) to "0" will clear the value to "0".
10	0: The falling edge position of touch probe 2 has not been stored. 1: The falling edge position of touch probe 2 has been stored. When the position feedback is stored in Touch probe neg2 neg value (P24765), "1" will be set. Setting Bit 13 of Touch probe function (P24760) to "0" will clear the value to "0".
11-15	(Reserved)

(4) Timing chart

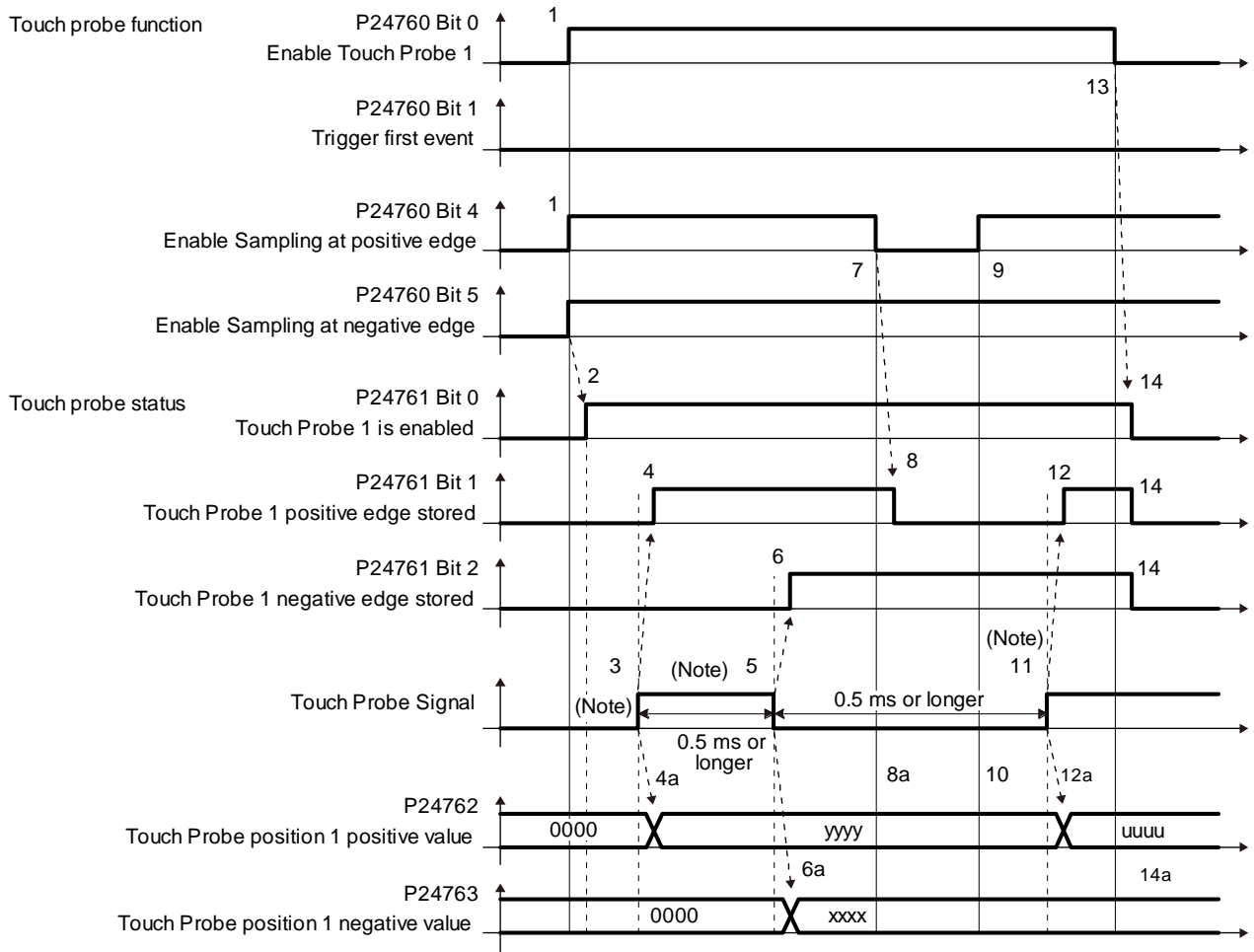

Note. Turn on and off Touch Probe Signal so that both the on time and off time are 0.5 ms or longer.

Transition No.	Object	Description
1	P24760 bit 0, 4, 5 = 1	Enables Touch Probe1. The rising edge and falling edge are enabled.
2	→ P24761 bit 0 = 1	Turns on the Touch Probe1 enable status.
3		Turns on Touch Probe Signal (TPR1).
4	→ P24761 bit 1 = 1	Turns on the Touch Probe1 positive edge stored status.
4a	→ P24762	Sets the latched position feedback for Touch probe position1 positive value.
5		Turns off Touch Probe Signal (TPR1).
6	→ P24761 bit 2 = 1	Turns on the Touch Probe1 negative edge stored status.
6a	→ P24763	Sets the latched position feedback for Touch probe position1 negative value.
7	P24760 bit 4 = 0	Turns off Sample positive edge. Rising edge detection is disabled.
8	→ P24761 bit 1 = 0	Turns off Touch Probe1 positive edge stored status.
8a	→ P24762	Touch probe position1 positive value does not change.
9	P24760 bit 4 = 1	Turns on Sample positive edge. Rising edge detection is enabled.
10	→ P24762	Touch probe position1 positive value does not change.
11		Turns on Touch Probe Signal (TPR1).
12	→ P24761 bit 1 = 1	Turns on the Touch Probe1 negative edge stored status.
12a	→ P24762	Sets the latched position feedback for Touch probe position1 negative value.
13	P24760 bit 0 = 0	Disables Touch Probe1.
14	→ P24761 bit 0, 1, 2 = 0	Clears all the status Bit.
14a	→ P24762, P24763	Touch probe position1 positive/negative value does not change.

(5) High-precision touch probe

Touch probe 2 supports high-precision touch probe. The normal touch probe has the latch function with precision of 55 μs. On the other hand, the high-precision touch probe latches precisely startup of TPR2 (touch probe 2) with precision of 2 μs. To use the high-precision touch probe, set [Pr. PD37] to "_ _ _ 1". While the high-precision touch probe is being used, the encoder pulse output function cannot be used. The precision of falling edge is 55 μs in this case as well.

20. PROFINET COMMUNICATION

20. 8. 7 One-touch tuning

Refer to section 6.2 for one-touch tuning. Using One-touch tuning mode (P11600) allows one-touch tuning from a upper side. The function is the same as previous one-touch tuning except that it can be executed via network and it is not compatible with the driver command method.

(1) Related object

PNU	Sub	Access	Name	Type	Default value	Description
11600	0	R/W	One-touch tuning mode	Unsigned8	0	One-touch tuning command Setting a value of "1" to "3" to this parameter starts one-touch tuning. After one-touch tuning is completed, the setting value automatically changes to "0". 0: During one-touch tuning stop 1: Basic mode 2: High mode 3: Low mode
11601	0	R	One-touch tuning status	Integer8	0	One-touch tuning status Regardless of whether one-touch tuning is properly completed or not, the setting value changes to 100% at the completion. (Unit: %)
11602	0	W	One-touch tuning Stop	Unsigned16	0	One-touch tuning stop command Writing "1EA5h" stops one-touch tuning. Writing a value other than "1EA5h" will trigger Error No. 0x02 (Low or high limit exceeded).
11603	0	W	One-touch tuning Clear	Unsigned16	0	The parameter changed in one-touch tuning can be returned to the value before the change. 0000h: Restores the default value 0001h: Restores the value before one-touch tuning. The setting value of the restored parameter is stored to the EEPROM.
11604	0	R	One-touch tuning Error Code	Unsigned16	0	One-touch tuning error code 0000h: Finished normally C000h: Tuning canceled C001h: Overshoot exceeded C002h: Servo-off during tuning C003h: Control mode error C004h: Time-out C005h: Load to motor inertia ratio misestimated C00Fh: One-touch tuning disabled

(2) Procedure of one-touch tuning via a network

Perform one-touch tuning via a network in the following procedure.

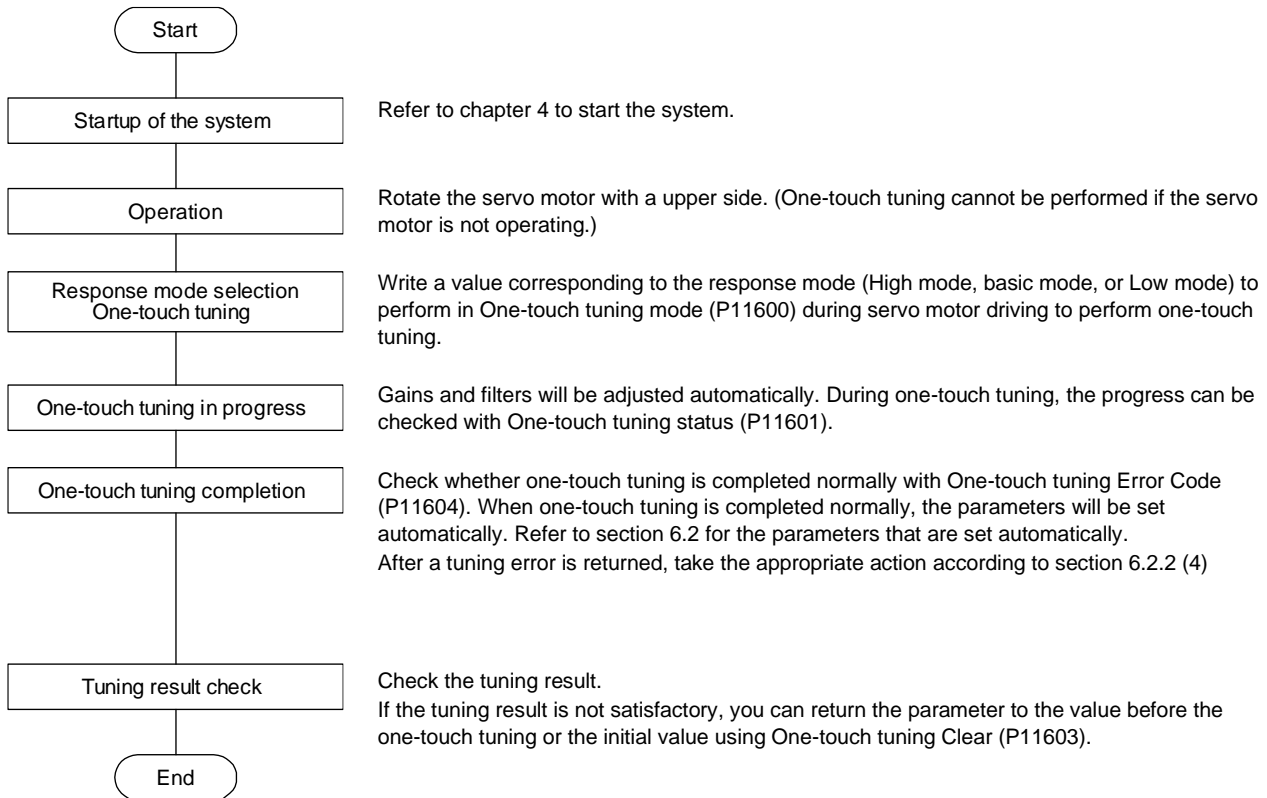

20. 8. 8 Driver life diagnosis function

You can check the cumulative energization time and the number of on/off times of the inrush relay based on the data in the driver. This function gives an indication of the replacement time for parts of the driver including a capacitor and a relay before they malfunction. The information of the driver life diagnosis function can be obtained with the following objects.

PNU	Sub	Access	Name	Type	Description
11288	0	R	Power ON cumulative time	Unsigned32	The cumulative energization time of the driver is returned.
11289	0	R	Number of inrush relay on/off times	Unsigned32	The number of on/off times of the inrush relay of the driver is returned.

20. PROFINET COMMUNICATION

20. 8. 9 Machine diagnosis

This function estimates the friction and vibrational component of the drive system in the equipment based on the data in the driver, and recognizes an error in the machine parts, including a ball screw and bearing. The information of the machine diagnosis function can be obtained with the following objects.

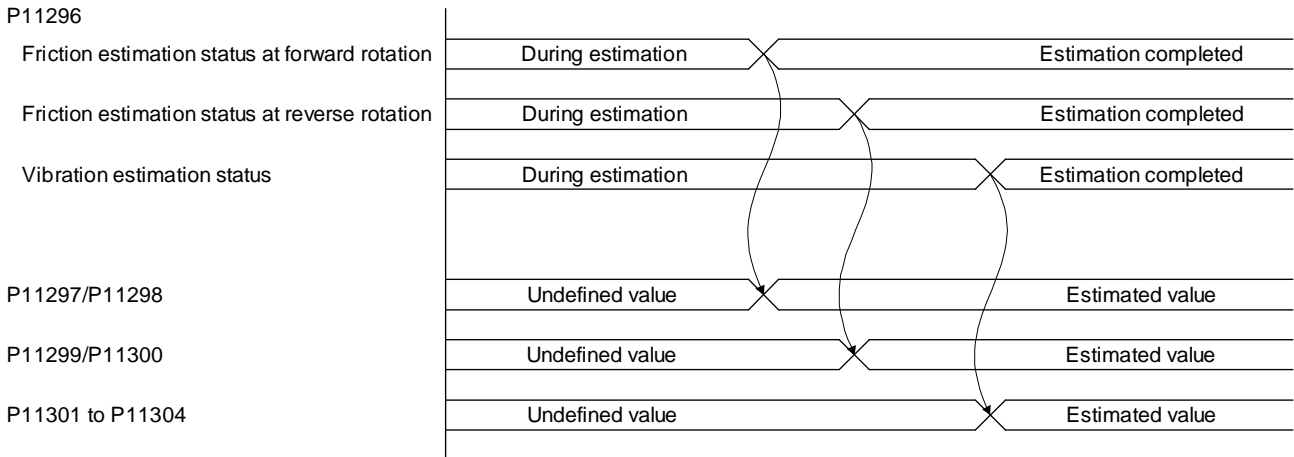

(1) Related object

PNU	Sub	Access	Name	Type	Description
11296	0	R	Machine diagnostic status	Unsigned16	Machine diagnostic status Refer to section 9.3.5 (2).
11297	0	R	Static friction torque at forward rotation	Integer16	Static friction torque at forward rotation Static friction torque at forward rotation is returned in increments of 0.1%.
11298	0	R	Dynamic friction torque at forward rotation (at rated speed)	Integer16	Dynamic friction torque at forward rotation (at rated speed) Dynamic friction torque at forward rotation at the rated speed is returned in increments of 0.1%.
11299	0	R	Static friction torque at reverse rotation	Integer16	Static friction torque at reverse rotation Static friction torque at reverse rotation is returned in increments of 0.1%.
11300	0	R	Dynamic friction torque at reverse rotation (at rated speed)	Integer16	Dynamic friction torque at reverse rotation (at rated speed) Dynamic friction torque at reverse rotation at rated speed is returned in increments of 0.1%.
11301	0	R	Oscillation frequency during motor stop	Integer16	Vibration frequency at stop/servo-lock Vibration frequency during stop/servo-lock is displayed in increments of 1 Hz.
11302	0	R	Vibration level during motor stop	Integer16	Vibration level at stop/servo-lock Vibration level during stop/servo-lock is displayed in increments of 0.1%.
11303	0	R	Oscillation frequency during motor operating	Integer16	Vibration frequency during operation Vibration frequency during operation is displayed in increments of 1 Hz.
11304	0	R	Vibration level during motor operating	Integer16	Vibration level during operation Vibration level during operation is displayed in increments of 0.1%.

20. PROFINET COMMUNICATION

20.8.10 Quick stop

Deceleration to a stop is executed with the Quick stop command of Control word 1 (PROFIdrive standard) and Controlword (CiA 402 standard) (P24640). The servo motor decelerates to a stop according to a time constant of Quick stop deceleration (P24709) and the state shifts to Switch on inhibited (Switch on disabled). The state shifts to Switch on inhibited (Switch on disabled) and the motor stops with the dynamic brake for tq. The following shows related PROFIdrive parameters.

PNU	Sub	Access	Name	Type	Default value	Description
24709	0	R/W	Quick stop deceleration	Unsigned32	100	Deceleration at deceleration to a stop by Quick stop Unit: ms
24666	0	R/W	Quick stop option code	Integer16	2	Refer to table 8.10 for details.

The operation method of deceleration to a stop can be specified with Quick stop option code (P24666). The following table shows the supported methods and the operations. Basic operation is the same as the forced stop function. The difference should be only the deceleration time constant.

Table 8.10 Quick stop option code

Setting value	Description
1	tq: The state shifts immediately to Switch on inhibited and the motor stops with dynamic brake. pp/pv: The servo motor decelerates to a stop with Profile deceleration (P24708) and the state shifts to Switch on inhibited (Switch on disabled). hm: The servo motor decelerates to a stop with Homing acceleration (P24730) and the state shifts to Switch on inhibited (Switch on disabled). (Not compatible) (Note)
2	pp/pv/hm/pt/jg/idx: The servo motor decelerates to a stop with Quick stop deceleration (P24709) and the state shifts to Switch on inhibited (Switch on disabled). tq: The state shifts immediately to the Switch on inhibited and the motor stops with dynamic brake.
3	The current is limited and the motor decelerates. Then, the state shifts to Switch on inhibited (Switch on disabled). (Not compatible) (Note)
4	The voltage is limited and the motor decelerates. Then, the state shifts to Switch on inhibited (Switch on disabled). (Not compatible) (Note)
5	The motor decelerates to a stop. Then, the state does not change from the Quick Stop Active (servo-on). (not compatible) (Note)
6	The motor decelerates to a stop with Quick stop deceleration (P24709). Then, the state does not change from the Quick Stop Active (servo-on). (not compatible) (Note)
7	The current is limited and the motor decelerates. Then, the state does not change from the Quick Stop Active (servo-on). (not compatible) (Note)
8	The voltage is limited and the motor decelerates. Then, the state does not change from the Quick Stop Active (servo-on). (not compatible) (Note)

Note. This is not supported by the driver.

20. PROFINET COMMUNICATION

20.8.11 Halt

When Halt Bit (Bit 8 of Controlword (CiA 402 standard)) is set to 1, the servo motor decelerates to a stop with the deceleration time constant of Homing acceleration (P24730), Profile deceleration (P24708) or the point table according to the setting of Halt option code (P24669). This function can be used in Profile mode, homing mode (hm) and point table method (pt/jg).

When Halt Bit is set to 0 at deceleration stop operation, the servo motor decelerates to a stop and returns to the operable state. The following table lists the related objects.

PNU	Sub	Access	Name	Type	Default value	Description
24669	0	R/W	Halt option code	Integer16	1	Setting for executing the Halt function Refer to table 8.11 for details.

The following table shows descriptions of Halt option code. However, in the tq mode, Torque demand value (P24692) is set to 0 regardless of Halt option code. The amount of torque change at this time can be set using Torque slope (P24711).

Table 8.11 Halt option code

Setting value	Description
1	The motor decelerates to a stop in accordance with the deceleration time constant of Profile deceleration (P24708) in pp/pv/jg, of Homing acceleration (P24730) in hm, and of the point table in pt, and the state does not change from Operation Enabled (servo-on).
2	The servo motor decelerates to a stop with Quick stop deceleration (P24709). The state does not change from Operation Enabled (servo-on). (Not compatible) (Note)
3	The current is limited and the servo motor decelerates to a stop. The state does not change from the Operation Enabled (servo-on). (Not compatible) (Note)
4	The voltage is limited and the servo motor decelerates to a stop. The state does not change from the Operation Enabled (servo-on). (Not compatible) (Note)

Note. This is not supported by the driver.

20.8.12 Ramp Stop

This decelerates the motor to a stop with the off command of Control word 1 (PROFIdrive standard) in the Operation state. The deceleration to a stop is according to a deceleration time constant of Profile deceleration (P24708).

PNU	Sub	Access	Name	Data Type	Description	Default
24708	0	R/W	Profile deceleration	Unsigned32	Deceleration time constant	0

PNU	Sub	Range	Units	EEP-ROM	Parameter
24708	0	Refer to the text.	ms	Possible	PT50

20. PROFINET COMMUNICATION

20. 8. 13 PROFIdrive parameter definitions related to alarms

Whether an alarm occurs or not in the slave can be detected on the master with bit 3 and bit 7 of Statusword via I/O communication. The alarm history of the latest alarm and 15 alarms that have occurred can be referred to by acquiring the following related object values in Acyclic.

PNU	Sub	Access	Name	Type	Description
10752	0	R	Alarm No.	Unsigned32	Alarm history (last alarm) Alarm No. XXXXVVVVh XXXX: Alarm No. VVVV: Alarm detail
	1	R	Alarm time (Hour)	Unsigned32	Alarm occurrence time Time passed from start-up of the driver (unit: time)
10753	0	R	Alarm No.	Unsigned32	Alarm history 1 Sub 0 and Sub 1 are omitted. (the same as P10752)
:	:	:	:	:	History 2 to 14 are omitted. (the same as P10752)
10767	0	R	Alarm No.	Unsigned32	Alarm history 15 Sub 0 and Sub 1 are omitted. (the same as P10752)
10816	0	W	Clear alarm history	Unsigned16	Writing "1EA5" clears Alarm history.
10817	0	R	Current alarm	Unsigned32	Occurring alarm XXXXVVVVh XXXX: Alarm No. VVVV: Alarm detail
10820	0	R	Parameter error number	Unsigned16	The number of parameter error numbers (The number of parameter error numbers caused [AL. 37].)
10821	0	R	(No. 1)	Unsigned16	The list of parameter error numbers (The list of parameter error numbers caused [AL. 37].) Parameter error No. 1 GGNNh GG: Group No. NN: Parameter No. GG 00: Pr. group PA 01: Pr. group PB 02: Pr. group PC 03: Pr. group PD 04: Pr. group PE 05: Pr. group PF 06: Parameter for manufacturer setting 07: Parameter for manufacturer setting 08: Parameter for manufacturer setting 09: Parameter for manufacturer setting 0A: Pr. group PS 0B: Pr. group PL 0C: Pr. group PT 0E: Pr. group PN
	:				
	15	R	(No. 16)	Unsigned16	Parameter error No. 15

20. PROFINET COMMUNICATION

20.8.14 Parameter

The parameter of the driver can be changed on the master in the Acyclic communication. However, once the power supply is shut off, the changed setting is not held at the next startup because the setting value is erased. To hold the changed setting even after the power supply is shut-off, save the parameter setting value to EEPROM using Store Parameters object (P4112).

To change the setting of the parameters where the changes are reflected by cycling the power (parameters whose symbols are preceded by *), change the value of the corresponding parameter and execute Store Parameters before cycling the power. Refer to chapter 5 for "*" of the parameter symbol. The following table lists the related objects.

PNU	Sub	Access	Name	Type	Description
8193	0	R/W	PA01	Integer32	[Pr. PA_ _] group
:	:	:	:	:	
8224	0	R/W	PA32	Integer32	[Pr. PB_ _] group
8321	0	R/W	PB01	Integer32	
:	:	:	:	:	[Pr. PC_ _] group
8384	0	R/W	PB64	Integer32	
8449	0	R/W	PC01	Integer32	[Pr. PD_ _] group
:	:	:	:	:	
8528	0	R/W	PC80	Integer32	[Pr. PE_ _] group
8577	0	R/W	PD01	Integer32	
:	:	:	:	:	[Pr. PF_ _] group
8624	0	R/W	PD48	Integer32	
8705	0	R/W	PE01	Integer32	[Pr. PL_ _] group
:	:	:	:	:	
8768	0	R/W	PE64	Integer32	[Pr. PT_ _] group
8833	0	R/W	PF01	Integer32	
:	:	:	:	:	[Pr. PN_ _] group
8896	0	R/W	PF64	Integer32	
9217	0	R/W	PL01	Integer32	[Pr. PT_ _] group
:	:	:	:	:	
9264	0	R/W	PL48	Integer32	[Pr. PN_ _] group
9345	0	R/W	PT01	Integer32	
:	:	:	:	:	[Pr. PN_ _] group
9424	0	R/W	PT80	Integer32	
9601	0	R/W	PN01	Integer32	[Pr. PN_ _] group
:	:	:	:	:	
9632	0	R/W	PN32	Integer32	

20. PROFINET COMMUNICATION

20. 8. 14. 1 Parameter enabling

The parameters whose symbols are preceded by * are enabled by the following operations. Refer to chapter 5 for "*" of the parameter symbol.

(1) Network disconnection

A parameter is enabled when a network disconnection switches the driver state to the state in which it waits for the upper side to be connected.

(2) State transition

A parameter is enabled when the upper side shifts from the ProcessData communication state to another state.

(3) Parameter enabling operation

A parameter is enabled by writing "1EA5h" to User parameter configuration object (P11572). You can operate this when the upper side is not using the ProcessData communication. Write it with Web server function for a upper side whose Acyclic communication is not enabled without using ProcessData communication.

The parameter enabling processing requires a maximum of about 100 ms. The read values of the User parameter configuration object are as follows. By checking the read value, the completion of the parameter enabling processing can be checked.

Value	Description
0	Parameter enabling processing is being executed.
1	Parameter enabling processing is not being executed. (The processing is completed.)

20. PROFINET COMMUNICATION

20. 8. 15 Degree function

(1) Description

Selecting "degree (_ 2 _)" in [Pr. PT01] allows for positioning with card coordinates (axis of rotation). The following shows the differences when "degree" is selected.

Item	Description
P24698: Target position	The range will be between -360.000° and 360.000°.
P24676: Position actual value	The range will be between 0° and 359.999°.
P24701: Software position limit	The range will be between 0° and 359.999°. A value outside the range is clamped within the range 0° to 359.999°.
P24699: Position range limit	The range will be between 0° and 359.999°.
P24762: Touch probe pos1 pos value	The range will be between 0° and 359.999°.
P24763: Touch probe pos1 neg value	The range will be between 0° and 359.999°.
P24764: Touch probe pos2 pos value	The range will be between 0° and 359.999°.
P24765: Touch probe pos2 neg value	The range will be between 0° and 359.999°.
P24700: Home offset	The range will be between 0° and 359.999°.
P11055: Current position	The range will be between 0° and 359.999°.
P11056: Command position	The range will be between 0° and 359.999°.
P11057: Command remaining distance	The range will be between 0° and 359.999°.
P11183: Alarm Monitor 47 Current position	The range will be between 0° and 359.999°.
P11184: Alarm Monitor 48 Command position	The range will be between 0° and 359.999°.
P11185: Alarm Monitor 49 Command remaining distance	The range will be between 0° and 359.999°.
Position range output address	The range will be between 0° and 359.999°. A value outside the range is clamped within the range 0° to 359.999°.

The positioning operation pattern can be changed with Positioning option code (P24818) for the degree setting as follows. Change the setting while the servo motor is stopped (Target reached is on). If the setting is changed while the servo motor is rotating (Target reached is off), the setting value is not applied immediately.

The new value is applied at a positioning start (Bit 4 of Controlword is turned on) after Target reached is once turned on.

Bit 7	Bit 6	Rotation direction definition for the axis of rotation	[Pr. PT03]
0	0	The servo motor rotates to the target position in a direction specified with a sign of the position data.	_ 0 _ _
0	1	The servo motor rotates in the address decreasing direction regardless of the sign of the position data.	_ 2 _ _
1	0	The servo motor rotates in the address increasing direction regardless of the sign of the position data.	_ 3 _ _
1	1	The servo motor rotates from the current position to the target position in the shorter direction. If the distances from the current position to the target position are the same for CCW and CW, the servo motor rotates in the CCW direction.	_ 1 _ _

(2) Sequences for degree setting

The following shows the operation patterns corresponding to the settings of Positioning option code (P24818).

(a) When POL is disabled ([Pr. PA14] = 0)

<p>Bit 7: 0 Bit 6: 0 The servo motor rotates in a direction specified with a sign of the position data.</p>	<p>Bit 7: 0 Bit 6: 1 The servo motor rotates only in the address decreasing direction.</p>	<p>Bit 7: 1 Bit 6: 0 The servo motor rotates only in the address increasing direction.</p>	<p>Bit 7: 1 Bit 6: 1 The servo motor rotates in the shorter direction.</p>

(b) When POL is enabled ([Pr. PA14] = 1)

<p>Bit 7: 0 Bit 6: 0 The servo motor rotates in a direction specified with a sign of the position data.</p>	<p>Bit 7: 0 Bit 6: 1 The servo motor rotates only in the address decreasing direction.</p>	<p>Bit 7: 1 Bit 6: 0 The servo motor rotates only in the address increasing direction.</p>	<p>Bit 7: 1 Bit 6: 1 The servo motor rotates in the shorter direction.</p>

20. PROFINET COMMUNICATION

20.9 OBJECT DICTIONARY

20.9.1 Store parameters

Writing "65766173h" (= ASCII code of "save") to Store Parameters (P4112) will save the parameter in the EEPROM of the driver.

The value saved in the EEPROM is set to the parameter at the next power-on. When setting parameters via PROFINET, use Store Parameters. The setting will not be changed immediately.

Executing Store Parameters takes about a maximum of 25 s because all parameters are written at the same time. Be careful not to shut off the power during writing.

PNU	Sub	Access	Name	Type	Description
4112	0	R/W	Save all parameters	Unsigned32	Saves all parameters. Writing "save" (= 65766173h) saves all the parameters which can be stored in the EEPROM.
	1 (not compatible) (Note)	R/W	Save communication parameters	Unsigned32	Saves communication parameters. Writing "save" (= 65766173h) saves the objects that can be saved in the EEPROM for the communication objects in the EEPROM.
	2 (not compatible) (Note)	R/W	Save application parameters	Unsigned32	Saves application parameters. Writing "save" (= 65766173h) saves the objects that can be saved in the EEPROM except for the communication objects (PROFIdrive parameters in the 900s) in the EEPROM.

Note. This is not supported by the driver.

The following values are read from this object. When a parameter is being saved, "0" is read. When no parameter is being saved, "1" is read.

Bit	Description
0	0: The parameter cannot be saved with the command. (A parameter is being saved.) 1: The parameter can be saved with the command. (No parameter is being saved.)
1	0: The parameter is not automatically saved.

20. PROFINET COMMUNICATION

20.9.2 PROFIdrive parameter (Manufacturer-specific) list

Group	Name	PNU
General Objects	Store parameters	4112
Servo Parameter Objects	PA_ _	8193 to 8224
	PB_ _	8321 to 8384
	PC_ _	8449 to 8528
	PD_ _	8577 to 8624
	PE_ _	8705 to 8768
	PF_ _	8833 to 8896
	PO_ _	8961 to 8992
	PL_ _	9217 to 9264
	PT_ _	9345 to 9424
	PN_ _	9601 to 9632
Alarm Objects	Alarm history newest	10752
	Alarm history	10753 to 10767
	Clear alarm history	10816
	Current alarm	10817
	Parameter error number	10820
	Parameter error list	10821
Monitor Objects	Cumulative feedback pulses	11009
	Servo motor speed	11010
	Droop pulses	11011
	Cumulative command pulses	11012
	Command pulse frequency	11013
	Regenerative load ratio	11016
	Effective load ratio	11017
	Peak load ratio	11018
	Instantaneous torque	11019
	Within one-revolution position	11020
	ABS counter	11021
	Load to motor inertia ratio	11022
	Bus voltage	11023
	Load-side cumulative feedback pulses	11024
	Load-side droop pulses	11025
	Load-side encoder information 1 Z-phase counter	11026
	Load-side encoder information 2	11027
	Temperature of motor thermistor	11031
	Motor-side cumu. feedback pulses (before gear)	11032
	Electrical angle	11033
	Motor-side/load-side position deviation	11043
	Motor-side/load-side speed deviation	11044
	Internal temperature of encoder	11045
	Settling time	11046
	Oscillation detection frequency	11047
	Number of tough drive operations	11048
	Unit power consumption	11053
	Unit total power consumption	11054
	Current position	11055
	Command position	11056
	Remaining command distance	11057
	Point table No./Program No./Station position No.	11058
	Alarm Monitor 1 Cumulative feedback pulses	11137
	Alarm Monitor 2 Servo motor speed	11138
Alarm Monitor 3 Droop pulses	11139	
Alarm Monitor 4 Cumulative command pulses	11140	
Alarm Monitor 5 Command pulse frequency	11141	
Alarm Monitor 8 Regenerative load ratio	11144	

20. PROFINET COMMUNICATION

Group	Name	PNU	
Monitor Objects	Alarm Monitor 9 Effective load ratio	11145	
	Alarm Monitor 10 Peak load ratio	11146	
	Alarm Monitor 11 Instantaneous torque	11147	
	Alarm Monitor 12 Within one-revolution position	11148	
	Alarm Monitor 13 ABS counter	11149	
	Alarm Monitor 14 Load to motor inertia ratio	11150	
	Alarm Monitor 15 Bus voltage	11151	
	Alarm Monitor 16 Load-side cumulative feedback pulses	11152	
	Alarm Monitor 17 Load-side droop pulses	11153	
	Alarm Monitor 18 Load-side encoder information 1 Z-phase counter	11154	
	Alarm Monitor 19 Load-side encoder information 2	11155	
	Alarm Monitor 23 Temperature of motor thermistor	11159	
	Alarm Monitor 24 Motor-side cumu. feedback pulses (before gear)	11160	
	Alarm Monitor 25 Electrical angle	11161	
	Alarm Monitor 35 Motor-side/load-side position deviation	11171	
	Alarm Monitor 36 Motor-side/load-side speed deviation	11172	
	Alarm Monitor 37 Internal temperature of encoder	11173	
	Alarm Monitor 38 Settling time	11174	
	Alarm Monitor 39 Oscillation detection frequency	11175	
	Alarm Monitor 40 Number of tough drive operations	11176	
	Alarm Monitor 45 Unit power consumption	11181	
	Alarm Monitor 46 Unit total power consumption	11182	
	Alarm Monitor 47 Current position	11183	
	Alarm Monitor 48 Command position	11184	
	Alarm Monitor 49 Command remaining distance	11185	
	Alarm Monitor 50 Point table No./Program No./Station position No.	11186	
	Manufacturer Specific Control Objects	External Output pin display	11281
		Power ON cumulative time	11288
		Number of inrush relay on/off times	11289
		Machine diagnostic status	11296
Static friction torque at forward rotation		11297	
Dynamic friction torque at forward rotation (at rated speed)		11298	
Static friction torque at reverse rotation		11299	
Dynamic friction torque at reverse rotation (at rated speed)		11300	
Oscillation frequency during motor stop		11301	
Vibration level during motor stop		11302	
Oscillation frequency during motor operating		11303	
Vibration level during motor operating		11304	
Control DI 1		11521	
Control DI 2		11522	
Control DI 3		11523	
Status DO 1		11537	
Status DO 2		11538	
Status DO 3		11539	
Status DO 5		11541	
Status DO 7		11543	
Velocity limit value		11552	
Motor rated speed		11560	
Manufacturer Device Name 2		11568	
Manufacturer Hardware Version 2		11569	
Manufacturer Software Version 2		11570	
Serial Number 2		11571	
User parameter configuration		11572	
Encoder status		11573	
One-touch tuning mode		11600	
One-touch tuning status		11601	
One-touch tuning Stop	11602		

20. PROFINET COMMUNICATION

Group	Name	PNU
Manufacturer Specific Control Objects	One-touch tuning Clear	11603
	One-touch tuning Error Code	11604
	Torque limit value 2	11627
PDS Control Objects	Error code	24639
	Controlword	24640
	Statusword	24641
	Quick stop option code	24666
	Halt option code	24669
	Modes of operation	24672
	Modes of operation display	24673
	Supported drive modes	25858
Position Control Function Objects	Position actual internal value	24675
	Position actual value	24676
	Following error window	24677
	Following error time out	24678
	Position window	24679
	Position window time	24680
	Positioning option code	24818
	Following error actual value	24820
	Control effort	24826
Profile Velocity Mode Objects	Velocity demand value	24683
	Velocity actual value	24684
	Velocity window	24685
	Velocity window time	24686
	Velocity threshold	24687
	Velocity threshold time	24688
	Target velocity	24831
Profile Torque Mode Objects	Target torque	24689
	Max torque	24690
	Torque demand value	24692
	Torque actual value	24695
	Torque slope	24711
	Torque profile type	24712
	Positive torque limit value	24800
Negative torque limit value	24801	
Profile Position Mode Objects	Target position	24698
	Position range limit	24699
	Software position limit	24701
	Max profile velocity	24703
	Max motor speed	24704
	Profile velocity	24705
	Profile acceleration	24707
	Profile deceleration	24708
	Quick stop deceleration	24709
Motion profile type	24710	
Homing Mode Objects	Home offset	24700
	Homing method	24728
	Homing speeds	24729
	Homing acceleration	24730
	Supported homing method	24803
Point Table Mode Objects	Target point table	11616
	Point demand value	11624
	Point actual value	11625
	Point table 001 to 255	10241 to 10495
	Point table error	10819
	M code actual value	11626

20. PROFINET COMMUNICATION

Group	Name	PNU
Factor Group Objects	Polarity	24702
	Position encoder resolution	24719
	Gear ratio	24721
	Feed constant	24722
	SI unit position	24744
	SI unit velocity	24745
Optional application FE Objects	Digital inputs	24829
	Digital outputs	24830
Touch Probe Function Objects	Touch probe function	24760
	Touch probe status	24761
	Touch probe pos1 pos value	24762
	Touch probe pos1 neg value	24763
	Touch probe pos2 pos value	24764
	Touch probe pos2 neg value	24765

20. PROFINET COMMUNICATION

20.9.3 PROFIdrive parameter (Manufacturer-specific)

This section describes the details of the Manufacturer-specific parameters for each group.

The following is shown in the "Access" column.

"R": Readable

"W": Writable

"R/W": Readable and writable

20.9.3.1 General Objects

(1) Store parameters (P4112)

PNU	Sub	Access	Name	Data Type	Description	Default
4112	0	R/W	Store all parameters	Unsigned32	Saves all parameters. Writing "save" (= 65766173h) saves all the parameters which can be stored in the EEPROM.	0
	1 (not compatible) (Note)	R/W	Store communication parameters	Unsigned32	Saves communication parameters. Writing "save" (= 65766173h) saves the objects that can be saved in the EEPROM for the communication objects in the EEPROM.	1
	2 (not compatible) (Note)	R/W	Store application parameters	Unsigned32	Saves application parameters. Writing "save" (= 65766173h) saves the objects that can be saved in the EEPROM except for the communication objects (PROFIdrive parameters in the 900s) in the EEPROM.	2

PNU	Sub	Range	Units	EEP-ROM	Parameter
4112	0	Refer to the followings.		Impossible	
	1			Impossible	
	2			Impossible	

Note. This is not supported by the driver.

Writing "65766173h" (= reverse order of ASCII code of "save") to the corresponding Subindex saves a parameter value in EEPROM.

Whether saving a parameter has been completed can be checked by reading this object. The read values are as follows.

Bit	Description
0	0: The parameter cannot be saved with the command. (A parameter is being saved.)
	1: The parameter can be saved with the command. (No parameter is being saved.)
1	0: The parameter is not automatically saved.

20. PROFINET COMMUNICATION

20.9.3.2 Servo Parameter Objects

(1) Servo Parameter Objects PA (P8193 to P8224)

The values of the basic setting parameters ([Pr. PA_ _]) can be obtained and set.

PNU	Sub	Access	Name	Data Type	Description	Default
8193	0	R/W	PA01	Integer32	PA01	
.	
.	
8224		R/W	PA32	Integer32	PA32	

PNU	Sub	Range	Units	EEP-ROM	Parameter
8193	0	Refer to "_ Driver Instruction Manual".		Possible	PA01
.					.
.					.
8224					PA32

(2) Servo Parameter Objects PB (P8321 to 8384)

The values of the gain/filter setting parameters ([Pr. PB_ _]) can be obtained and set.

PNU	Sub	Access	Name	Data Type	Description	Default
8321	0	R/W	PB01	Integer32	PB01	
.	
.	
8384		R/W	PB64	Integer32	PB64	

PNU	Sub	Range	Units	EEP-ROM	Parameter
8321	0	Refer to "_ Driver Instruction Manual".		Possible	PB01
.					.
.					.
8384					PB64

(3) Servo Parameter Objects PC (P8449 to P8528)

The values of the extension setting parameters ([Pr. PC_ _]) can be obtained and set.

PNU	Sub	Access	Name	Data Type	Description	Default
8449	0	R/W	PC01	Integer32	PC01	
.	
.	
8528		R/W	PC80	Integer32	PC80	

PNU	Sub	Range	Units	EEP-ROM	Parameter
8449	0	Refer to "_ Driver Instruction Manual".		Possible	PC01
.					.
.					.
8528					PC80

20. PROFINET COMMUNICATION

(4) Servo Parameter Objects PD (P8577 to P8624)

The values of the I/O setting parameters ([Pr. PD_ _]) can be obtained and set.

PNU	Sub	Access	Name	Data Type	Description	Default
8577	0	R/W	PD01	Integer32	PD01	
.	
.	
.	
8624		R/W	PD48	Integer32	PD48	

PNU	Sub	Range	Units	EEP-ROM	Parameter
8577	0	Refer to "_ Driver Instruction Manual".		Possible	PD01
.					.
.					.
8624					PD48

(5) Servo Parameter Objects PE (P8705 to 8768)

The values of the extension setting 2 parameters ([Pr. PE_ _]) can be obtained and set.

PNU	Sub	Access	Name	Data Type	Description	Default
8705	0	R/W	PE01	Integer32	PE01	
.	
.	
.	
8768		R/W	PE64	Integer32	PE64	

PNU	Sub	Range	Units	EEP-ROM	Parameter
8705	0	Refer to "_ Driver Instruction Manual".		Possible	PE01
.					.
.					.
8768					PE64

(6) Servo Parameter Objects PF (P8833 to 8896)

The values of the extension setting 3 parameters ([Pr. PF_ _]) can be obtained and set.

PNU	Sub	Access	Name	Data Type	Description	Default
8833	0	R/W	PF01	Integer32	PF01	
.	
.	
.	
8896		R/W	PF64	Integer32	PF64	

PNU	Sub	Range	Units	EEP-ROM	Parameter
8833	0	Refer to "_ Driver Instruction Manual".		Possible	PF01
.					.
.					.
8896					PF64

20. PROFINET COMMUNICATION

(7) Servo Parameter Objects PL (P9217 to 9264)

The values of the linear servo motor/DD motor setting parameters ([Pr. PL_ _]) can be obtained and set.

PNU	Sub	Access	Name	Data Type	Description	Default
9217	0	R/W	PL01	Integer32	PL01	
.	
.	
9264		R/W	PL48	Integer32	PL48	

PNU	Sub	Range	Units	EEP-ROM	Parameter
9217	0	Refer to "_ Driver Instruction Manual".		Possible	PL01
.					.
.					.
9264					PL48

(8) Servo Parameter Objects PT (P9345 to 9424)

The values of the positioning control parameters ([Pr. PT_ _]) can be obtained and set.

PNU	Sub	Access	Name	Data Type	Description	Default
9345	0	R/W	PT01	Integer32	PT01	
.	
.	
9424		R/W	PT80	Integer32	PT80	

PNU	Sub	Range	Units	EEP-ROM	Parameter
9345	0	Refer to "_ Driver Instruction Manual".		Possible	PT01
.					.
.					.
9424					PT80

(9) Servo Parameter Objects PN (P9601 to 9632)

The values of the network setting parameters ([Pr. PN_ _]) can be obtained and set.

PNU	Sub	Access	Name	Data Type	Description	Default
9601	0	R/W	PN01	Integer32	PN01	
.	
.	
9632		R/W	PN32	Integer32	PN32	

PNU	Sub	Range	Units	EEP-ROM	Parameter
9601	0	Refer to "_ Driver Instruction Manual".		Possible	PN01
.					.
.					.
9632					PN32

20. PROFINET COMMUNICATION

20.9.3.3 Alarm Objects

(1) Alarm history newest (P10752)

The latest alarm information of the alarm history is returned.

PNU	Sub	Access	Name	Data Type	Description	Default
10752	0	R	Alarm No.	Array [2] Unsigned32	The number of the alarm that has occurred is returned. The description is as follows. When no history exists, "0" is returned. Bit 0 to Bit 15: Alarm detail number Bit 16 to Bit 31: Alarm number If [AL. 16.3] occurs, "00160003h" is returned.	0
	1	R	Alarm time (Hour)		Alarm occurrence time is returned. When no history exists, "0" is returned. Unit: [hour]	0

PNU	Sub	Range	Units	EEP-ROM	Parameter
10752	0	00000000h to FFFFFFFFh	hour	Possible	
	1	00000000h to FFFFFFFFh			

(2) Alarm history 1 (P10753) to Alarm history 15 (P10767)

The second-latest alarm information of the alarm history is returned.

PNU	Sub	Access	Name	Data Type	Description	Default
10753 to 10767	0	R	Alarm No.	Array [2] Unsigned32	The number of the alarm that has occurred is returned. The description is as follows. When no history exists, "0" is returned. Bit 0 to Bit 15: Alarm detail number Bit 16 to Bit 31: Alarm number If [AL. 16.3] occurs, "00160003h" is returned.	0
	1	R	Alarm time (Hour)		Alarm occurrence time is returned. When no history exists, "0" is returned. Unit: [hour]	0

PNU	Sub	Range	Units	EEP-ROM	Parameter
10753 to 10767	0	00000000h to FFFFFFFFh	hour	Possible	
	1	00000000h to FFFFFFFFh			

(3) Clear alarm history (P10816)

Writing "1EA5h" to this object clears the alarm history.

PNU	Sub	Access	Name	Data Type	Description	Default
10816	0	W	Clear alarm history	Unsigned16	Alarm history clear	

PNU	Sub	Range	Units	EEP-ROM	Parameter
10816	0	Refer to the text.		Impossible	

20. PROFINET COMMUNICATION

(4) Current alarm (P10817)

The number of the current alarm is returned. When no alarm has occurred, "00000000h" is returned. The description of the values is as follows. If [AL. 16.3] occurs, "00160003h" is returned.

PNU	Sub	Access	Name	Data Type	Description	Default
10817	0	R	Current alarm	Unsigned32	Current alarm Bit 0 to Bit 15: Alarm detail number Bit 16 to Bit 31: Alarm number	

PNU	Sub	Range	Units	EEP-ROM	Parameter
10817	0	00000000h to FFFFFFFFh		Impossible	

(5) Parameter error number (P10820)

When [AL. 37 Parameter error] has occurred, the number of the parameters which cause the error is returned. Refer to Parameter error list (P10821) for the number of each parameter which causes the error.

PNU	Sub	Access	Name	Data Type	Description	Default
10820	0	R	Parameter error number	Unsigned16	Parameter error No.	

PNU	Sub	Range	Units	EEP-ROM	Parameter
10820	0	0000h to 01F4h		Impossible	

(6) Parameter error list (P10821)

When [AL. 37 Parameter error] has occurred, the number of the parameter which causes the error is returned. For forms of parameter error Nos., refer to chapter 8.13. If [Pr. PC01] is an error factor, "0201h" is returned.

If more than 17 parameter errors have occurred, the 17th and later parameter errors are returned after the parameters are corrected and the power is cycled.

PNU	Sub	Access	Name	Data Type	Description	Default
10821	0	R	No. 1	Array [64] Unsigned16	Parameter error No. 1	
	1		No. 2		Parameter error No. 2	
	·		·		·	·
	·		·		·	·
	15		No. 16		Parameter error No. 16	

PNU	Sub	Range	Units	EEP-ROM	Parameter
10821	0	0000h to FFFFh		Impossible	
	1				
	·				
	·				
	15				

20. PROFINET COMMUNICATION

20.9.3.4 Monitor Objects

(1) Cumulative feedback pulses (P11009)

The cumulative feedback pulses are returned. Writing "0000 1EA5h" to this object clears the cumulative feedback pulses.

PNU	Sub	Access	Name	Data Type	Description	Default
11009	0	R/W	Cumulative feedback pulses	Integer32	Cumulative feedback pulses	

PNU	Sub	Range	Units	EEP-ROM	Parameter
11009	0	80000000h to 7FFFFFFFh	pulse	Impossible	

(2) Servo motor speed (P11010)

The servo motor speed is returned.

Unit: [r/min]

PNU	Sub	Access	Name	Data Type	Description	Default
11010	0	R	Servo motor speed	Integer32	Servo motor speed	

PNU	Sub	Range	Units	EEP-ROM	Parameter
11010	0	80000000h to 7FFFFFFFh	Refer to the text.	Impossible	

(3) Droop pulses (P11011)

The droop pulses (encoder unit) are returned.

PNU	Sub	Access	Name	Data Type	Description	Default
11011	0	R	Droop pulses	Integer32	Droop pulses (encoder unit)	

PNU	Sub	Range	Units	EEP-ROM	Parameter
11011	0	80000000h to 7FFFFFFFh	pulse	Impossible	

(4) Cumulative command pulses (P11012)

The cumulative command pulses are returned.

PNU	Sub	Access	Name	Data Type	Description	Default
11012	0	R	Cumulative command pulses	Integer32	Cumulative command pulses	

PNU	Sub	Range	Units	EEP-ROM	Parameter
11012	0	80000000h to 7FFFFFFFh	pulse	Impossible	

(5) Command pulse frequency (P11013)

The command pulse frequency is returned.

PNU	Sub	Access	Name	Data Type	Description	Default
11013	0	R	Command pulse frequency	Integer32	Command pulse frequency	

PNU	Sub	Range	Units	EEP-ROM	Parameter
11013	0	80000000h to 7FFFFFFFh	kpulse/s	Impossible	

20. PROFINET COMMUNICATION

(6) Regenerative load ratio (P11016)

The regenerative load ratio is returned.

PNU	Sub	Access	Name	Data Type	Description	Default
11016	0	R	Regenerative load ratio	Unsigned16	Regenerative load ratio	

PNU	Sub	Range	Units	EEP-ROM	Parameter
11016	0	0000h to FFFFh	%	Impossible	

(7) Effective load ratio (P11017)

The effective load ratio is returned.

PNU	Sub	Access	Name	Data Type	Description	Default
11017	0	R	Effective load ratio	Unsigned16	Effective load ratio	

PNU	Sub	Range	Units	EEP-ROM	Parameter
11017	0	0000h to FFFFh	%	Impossible	

(8) Peak load ratio (P11018)

The peak load ratio is returned.

PNU	Sub	Access	Name	Data Type	Description	Default
11018	0	R	Peak load ratio	Unsigned16	Peak load ratio	

PNU	Sub	Range	Units	EEP-ROM	Parameter
11018	0	0000h to FFFFh	%	Impossible	

(9) Instantaneous torque (P11019)

The instantaneous torque is returned.

PNU	Sub	Access	Name	Data Type	Description	Default
11019	0	R	Instantaneous torque	Integer16	Instantaneous torque	

PNU	Sub	Range	Units	EEP-ROM	Parameter
11019	0	8000h to 7FFFh	%	Impossible	

(10) Within one-revolution position (P11020)

The position within one-revolution is returned.

PNU	Sub	Access	Name	Data Type	Description	Default
11020	0	R	Within one-revolution position	Integer32	Position within one-revolution	

PNU	Sub	Range	Units	EEP-ROM	Parameter
11020	0	80000000h to 7FFFFFFFh	pulse	Impossible	

(11) ABS counter (P11021)

The ABS counter is returned.

PNU	Sub	Access	Name	Data Type	Description	Default
11021	0	R	ABS counter	Integer32	ABS counter	

PNU	Sub	Range	Units	EEP-ROM	Parameter
11021	0	80000000h to 7FFFFFFFh	pulse	Impossible	

20. PROFINET COMMUNICATION

(12) Load to motor inertia ratio (P11022)

The load to motor inertia ratio is returned.

PNU	Sub	Access	Name	Data Type	Description	Default
11022	0	R	Load to motor inertia ratio	Unsigned16	Load to motor inertia ratio	

PNU	Sub	Range	Units	EEP-ROM	Parameter
11022	0	0000h to FFFFh	0.01 times	Impossible	

(13) Bus voltage (P11023)

The bus voltage is returned.

PNU	Sub	Access	Name	Data Type	Description	Default
11023	0	R	Bus voltage	Unsigned16	Bus voltage	

PNU	Sub	Range	Units	EEP-ROM	Parameter
11023	0	0000h to FFFFh	V	Impossible	

(14) Load-side cumulative feedback pulses (P11024)

The load-side cumulative feedback pulses (load-side encoder unit) are returned.

PNU	Sub	Access	Name	Data Type	Description	Default
11024	0	R	Load-side cumulative feedback pulses	Integer32	Load-side cumulative feedback pulses (load-side encoder unit)	

PNU	Sub	Range	Units	EEP-ROM	Parameter
11024	0	80000000h to 7FFFFFFFh	pulse	Impossible	

(15) Load-side droop pulses (P11025)

The load-side droop pulses are returned.

PNU	Sub	Access	Name	Data Type	Description	Default
11025	0	R	Load-side droop pulses	Integer32	Load-side droop pulses	

PNU	Sub	Range	Units	EEP-ROM	Parameter
11025	0	80000000h to 7FFFFFFFh	pulse	Impossible	

(16) Load-side encoder information 1 Z-phase counter (P11026)

The load-side encoder information 1 is returned.

PNU	Sub	Access	Name	Data Type	Description	Default
11026	0	R	Load-side encoder information 1 Z-phase counter	Integer32	Load-side encoder information 1	

PNU	Sub	Range	Units	EEP-ROM	Parameter
11026	0	80000000h to 7FFFFFFFh	pulse	Impossible	

20. PROFINET COMMUNICATION

(17) Load-side encoder information 2 (P11027)

The load-side encoder information 2 is returned.

PNU	Sub	Access	Name	Data Type	Description	Default
11027	0	R	Load-side encoder information 2	Integer32	Load-side encoder information 2	

PNU	Sub	Range	Units	EEP-ROM	Parameter
11027	0	80000000h to 7FFFFFFFh	rev	Impossible	

(18) Temperature of motor thermistor (P11031)

The temperature of servo motor thermistor is returned.

PNU	Sub	Access	Name	Data Type	Description	Default
11031	0	R	Temperature of motor thermistor	Integer16	Servo motor thermistor temperature	

PNU	Sub	Range	Units	EEP-ROM	Parameter
11031	0	8000h to 7FFFh	°C	Impossible	

(19) Motor-side cumu. feedback pulses (before gear) (P11032)

The cumulative feedback pulses are returned.

PNU	Sub	Access	Name	Data Type	Description	Default
11032	0	R	Motor-side cumu. feedback pulses (before gear)	Integer32	Cumulative feedback pulses	

PNU	Sub	Range	Units	EEP-ROM	Parameter
11032	0	80000000h to 7FFFFFFFh	pulse	Impossible	

(20) Electrical angle (P11033)

The electrical angle is returned.

PNU	Sub	Access	Name	Data Type	Description	Default
11033	0	R	Electrical angle	Integer32	Electrical angle	

PNU	Sub	Range	Units	EEP-ROM	Parameter
11033	0	80000000h to 7FFFFFFFh	pulse	Impossible	

(21) Motor-side/load-side position deviation (P11043)

The servo motor-side/load-side position deviation is returned.

PNU	Sub	Access	Name	Data Type	Description	Default
11043	0	R	Motor-side/load-side position deviation	Integer32	Servo motor-side/load-side position deviation	

PNU	Sub	Range	Units	EEP-ROM	Parameter
11043	0	80000000h to 7FFFFFFFh	pulse	Impossible	

20. PROFINET COMMUNICATION

(22) Motor-side/load-side speed deviation (P11044)

The servo motor-side/load-side speed deviation is returned.

PNU	Sub	Access	Name	Data Type	Description	Default
11044	0	R	Motor-side/load-side speed deviation	Integer32	Servo motor-side/load-side speed deviation	

PNU	Sub	Range	Units	EEP-ROM	Parameter
11044	0	80000000h to 7FFFFFFFh	r/min	Impossible	

(23) Internal temperature of encoder (P11045)

The internal temperature of encoder is returned.

PNU	Sub	Access	Name	Data Type	Description	Default
11045	0	R	Internal temperature of encoder	Integer16	Internal temperature of encoder	

PNU	Sub	Range	Units	EEP-ROM	Parameter
11045	0	8000h to 7FFFh	°C	Impossible	

(24) Settling time (P11046)

The settling time is returned.

PNU	Sub	Access	Name	Data Type	Description	Default
11046	0	R	Settling time	Integer16	Settling time	

PNU	Sub	Range	Units	EEP-ROM	Parameter
11046	0	8000h to 7FFFh	ms	Impossible	

(25) Oscillation detection frequency (P11047)

The oscillation detection frequency is returned.

PNU	Sub	Access	Name	Data Type	Description	Default
11047	0	R	Oscillation detection frequency	Integer16	Oscillation detection frequency	

PNU	Sub	Range	Units	EEP-ROM	Parameter
11047	0	8000h to 7FFFh	Hz	Impossible	

(26) Number of tough drive operations (P11048)

The number of tough drive operations is returned.

PNU	Sub	Access	Name	Data Type	Description	Default
11048	0	R	Number of tough drive operations	Unsigned16	Number of tough drive operations	

PNU	Sub	Range	Units	EEP-ROM	Parameter
11048	0	0000h to FFFFh	number of times	Impossible	

20. PROFINET COMMUNICATION

(27) Unit power consumption (P11053)

The unit power consumption is returned.

PNU	Sub	Access	Name	Data Type	Description	Default
11053	0	R	Unit power consumption	Integer16	Unit power consumption	

PNU	Sub	Range	Units	EEP-ROM	Parameter
11053	0	8000h to 7FFFh	W	Impossible	

(28) Unit total power consumption (P11054)

The unit total power consumption is returned.

PNU	Sub	Access	Name	Data Type	Description	Default
11054	0	R	Unit total power consumption	Integer32	Unit total power consumption	

PNU	Sub	Range	Units	EEP-ROM	Parameter
11054	0	80000000h to 7FFFFFFFh	Wh	Impossible	

(29) Current position (P11055)

The current position is returned. In the indexer method, the value is fixed to "0".

PNU	Sub	Access	Name	Data Type	Description	Default
11055	0	R	Current position	Integer32	Current position	

PNU	Sub	Range	Units	EEP-ROM	Parameter
11055	0	80000000h to 7FFFFFFFh	pos units	Impossible	

(30) Command position (P11056)

The command position is returned. In the indexer method, the value is fixed to "0".

PNU	Sub	Access	Name	Data Type	Description	Default
11056	0	R	Command position	Integer32	Command position	

PNU	Sub	Range	Units	EEP-ROM	Parameter
11056	0	80000000h to 7FFFFFFFh	pos units	Impossible	

(31) Remaining command distance (P11057)

The command remaining distance is returned.

PNU	Sub	Access	Name	Data Type	Description	Default
11057	0	R	Remaining command distance	Integer32	Command remaining distance	

PNU	Sub	Range	Units	EEP-ROM	Parameter
11057	0	80000000h to 7FFFFFFFh	pos units	Impossible	

20. PROFINET COMMUNICATION

(32) Point table No./Program No./Station position No. (P11058)

Point table No. or station position No. is returned.

PNU	Sub	Access	Name	Data Type	Description	Default
11058	0	R	Point table No./Program No./Station position No.	Integer16	Point table No./station position No.	

PNU	Sub	Range	Units	EEP-ROM	Parameter
11058	0	0000h to 00FFh		Impossible	

(33) Alarm Monitor 1 Cumulative feedback pulses (P11137)

The cumulative feedback pulses at alarm occurrence are returned.

PNU	Sub	Access	Name	Data Type	Description	Default
11137	0	R	Alarm Monitor 1 Cumulative feedback pulses	Integer32	Cumulative feedback pulses at alarm occurrence	

PNU	Sub	Range	Units	EEP-ROM	Parameter
11137	0	80000000h to 7FFFFFFFh	pulse	Impossible	

(34) Alarm Monitor 2 Alarm Monitor 2 Servo motor speed (P11138)

The servo motor speed at alarm occurrence is returned.

Unit: [r/min]

PNU	Sub	Access	Name	Data Type	Description	Default
11138	0	R	Alarm Monitor 2 Servo motor speed	Integer32	Servo motor speed at alarm occurrence	

PNU	Sub	Range	Units	EEP-ROM	Parameter
11138	0	80000000h to 7FFFFFFFh	Refer to the text.	Impossible	

(35) Alarm Monitor 3 Droop pulses (P11139)

The droop pulses at alarm occurrence are returned.

PNU	Sub	Access	Name	Data Type	Description	Default
11139	0	R	Alarm Monitor 3 Droop pulses	Integer32	Droop pulses at alarm occurrence	

PNU	Sub	Range	Units	EEP-ROM	Parameter
11139	0	80000000h to 7FFFFFFFh	pulse	Impossible	

(36) Alarm Monitor 4 Cumulative command pulses (P11140)

The cumulative command pulses (encoder unit) at alarm occurrence are returned.

PNU	Sub	Access	Name	Data Type	Description	Default
11140	0	R	Alarm Monitor 4 Cumulative command pulses	Integer32	Cumulative command pulses (encoder unit) at alarm occurrence	

PNU	Sub	Range	Units	EEP-ROM	Parameter
11140	0	80000000h to 7FFFFFFFh	pulse	Impossible	

20. PROFINET COMMUNICATION

(37) Alarm Monitor 5 Command pulse frequency (P11141)

The command pulse frequency at alarm occurrence is returned.

PNU	Sub	Access	Name	Data Type	Description	Default
11141	0	R	Alarm Monitor 5 Command pulse frequency	Integer32	Command pulse frequency at alarm occurrence	

PNU	Sub	Range	Units	EEP-ROM	Parameter
11141	0	80000000h to 7FFFFFFFh	kpulse/s	Impossible	

(38) Alarm Monitor 8 Regenerative load ratio (P11144)

The regenerative load ratio at alarm occurrence is returned.

PNU	Sub	Access	Name	Data Type	Description	Default
11144	0	R	Alarm Monitor 8 Regenerative load ratio	Unsigned16	Regenerative load ratio at alarm occurrence	

PNU	Sub	Range	Units	EEP-ROM	Parameter
11144	0	0000h to FFFFh	%	Impossible	

(39) Alarm Monitor 9 Effective load ratio (P11145)

The effective load ratio at alarm occurrence is returned.

PNU	Sub	Access	Name	Data Type	Description	Default
11145	0	R	Alarm Monitor 9 Effective load ratio	Unsigned16	Effective load ratio at alarm occurrence	

PNU	Sub	Range	Units	EEP-ROM	Parameter
11145	0	0000h to FFFFh	%	Impossible	

(40) Alarm Monitor 10 Peak load ratio (P11146)

The peak load ratio at alarm occurrence is returned.

PNU	Sub	Access	Name	Data Type	Description	Default
11146	0	R	Alarm Monitor 10 Peak load ratio	Unsigned16	Peak load ratio at alarm occurrence	

PNU	Sub	Range	Units	EEP-ROM	Parameter
11146	0	0000h to FFFFh	%	Impossible	

(41) Alarm Monitor 11 Instantaneous torque (P11147)

The instantaneous torque at alarm occurrence is returned.

PNU	Sub	Access	Name	Data Type	Description	Default
11147	0	R	Alarm Monitor 11 Instantaneous torque	Integer16	Instantaneous torque at alarm occurrence	

PNU	Sub	Range	Units	EEP-ROM	Parameter
11147	0	8000h to 7FFFh	%	Impossible	

20. PROFINET COMMUNICATION

(42) Alarm Monitor 12 Within one-revolution position (P11148)

The position within one-revolution at alarm occurrence is returned.

PNU	Sub	Access	Name	Data Type	Description	Default
11148	0	R	Alarm Monitor 12 Within one-revolution position	Integer32	Position within one-revolution at alarm occurrence	

PNU	Sub	Range	Units	EEP-ROM	Parameter
11148	0	80000000h to 7FFFFFFFh	pulse	Impossible	

(43) Alarm Monitor 13 ABS counter (P11149)

The ABS counter at alarm occurrence is returned.

PNU	Sub	Access	Name	Data Type	Description	Default
11149	0	R	Alarm Monitor 13 ABS counter	Integer32	ABS counter at alarm occurrence	

PNU	Sub	Range	Units	EEP-ROM	Parameter
11149	0	80000000h to 7FFFFFFFh	rev	Impossible	

(44) Alarm Monitor 14 Load to motor inertia ratio (P11150)

The load to motor inertia ratio at alarm occurrence is returned.

PNU	Sub	Access	Name	Data Type	Description	Default
11150	0	R	Alarm Monitor 14 Load to motor inertia ratio	Unsigned16	Load to motor inertia ratio at alarm occurrence	

PNU	Sub	Range	Units	EEP-ROM	Parameter
11150	0	0000h to FFFFh	0.1times	Impossible	

(45) Alarm Monitor 15 Bus voltage (P11151)

The bus voltage at alarm occurrence is returned.

PNU	Sub	Access	Name	Data Type	Description	Default
11151	0	R	Alarm Monitor 15 Bus voltage	Integer32	Bus voltage at alarm occurrence	

PNU	Sub	Range	Units	EEP-ROM	Parameter
11151	0	80000000h to 7FFFFFFFh	V	Impossible	

(46) Alarm Monitor 16 Load-side cumulative feedback pulses (P11152)

The load-side cumulative feedback pulses at alarm occurrence are returned.

PNU	Sub	Access	Name	Data Type	Description	Default
11152	0	R	Alarm Monitor 16 Load-side cumulative feedback pulses	Integer32	Load-side cumulative feedback pulses at alarm occurrence	

PNU	Sub	Range	Units	EEP-ROM	Parameter
11152	0	80000000h to 7FFFFFFFh	pulse	Impossible	

20. PROFINET COMMUNICATION

(47) Alarm Monitor 17 Load-side droop pulses (P11153)

The load-side droop pulses (load-side encoder unit) at alarm occurrence are returned.

PNU	Sub	Access	Name	Data Type	Description	Default
11153	0	R	Alarm Monitor 17 Load-side droop pulses	Integer32	Load-side droop pulses (load-side encoder unit) at alarm occurrence	

PNU	Sub	Range	Units	EEP-ROM	Parameter
11153	0	80000000h to 7FFFFFFFh	pulse	Impossible	

(48) Alarm Monitor 18 Load-side encoder information 1 Z-phase counter (P11153)

The load-side encoder information 1 at alarm occurrence is returned.

PNU	Sub	Access	Name	Data Type	Description	Default
11154	0	R	Alarm Monitor 18 Load-side encoder information 1 Z-phase counter	Integer32	Load-side encoder information 1 at alarm occurrence	

PNU	Sub	Range	Units	EEP-ROM	Parameter
11154	0	80000000h to 7FFFFFFFh	pulse	Impossible	

(49) Alarm Monitor 19 Load-side encoder information 2 (P11155)

The load-side encoder information 2 at alarm occurrence is returned.

PNU	Sub	Access	Name	Data Type	Description	Default
11155	0	R	Alarm Monitor 19 Load-side encoder information 2	Integer32	Load-side encoder information 2 at alarm occurrence	

PNU	Sub	Range	Units	EEP-ROM	Parameter
11155	0	80000000h to 7FFFFFFFh	rev	Impossible	

(50) Alarm Monitor 23 Temperature of motor thermistor (P11159)

The temperature of servo motor thermistor at alarm occurrence is returned.

PNU	Sub	Access	Name	Data Type	Description	Default
11159	0	R	Alarm Monitor 23 Temperature of motor thermistor	Integer32	Temperature of servo motor thermistor at alarm occurrence	

PNU	Sub	Range	Units	EEP-ROM	Parameter
11159	0	80000000h to 7FFFFFFFh	°C	Impossible	

(51) Alarm Monitor 24 Motor-side cumu. feedback pulses (before gear) (P11160)

The cumulative feedback pulses (servo motor-side unit) at alarm occurrence are returned.

PNU	Sub	Access	Name	Data Type	Description	Default
11160	0	R	Alarm Monitor 24 Motor-side cumu. feedback pulses (before gear)	Integer32	Cumulative feedback pulses (servo motor-side unit) at alarm occurrence	

PNU	Sub	Range	Units	EEP-ROM	Parameter
11160	0	80000000h to 7FFFFFFFh	pulse	Impossible	

20. PROFINET COMMUNICATION

(52) Alarm Monitor 25 Electrical angle (P11161)

The electrical angle at alarm occurrence is returned.

PNU	Sub	Access	Name	Data Type	Description	Default
11161	0	R	Alarm Monitor 25 Electrical angle	Integer32	Electrical angle at alarm occurrence	

PNU	Sub	Range	Units	EEP-ROM	Parameter
11161	0	80000000h to 7FFFFFFFh	pulse	Impossible	

(53) Alarm Monitor 35 Motor-side/load-side position deviation (P11171)

The motor-side/load-side position deviation at alarm occurrence is returned.

PNU	Sub	Access	Name	Data Type	Description	Default
11171	0	R	Alarm Monitor 35 Motor-side/load-side position deviation	Integer32	Motor-side/load-side position deviation at alarm occurrence	

PNU	Sub	Range	Units	EEP-ROM	Parameter
11171	0	80000000h to 7FFFFFFFh	pulse	Impossible	

(54) Alarm Monitor 36 Motor-side/load-side speed deviation (P11172)

The servo motor-side/load-side speed deviation at alarm occurrence is returned.

PNU	Sub	Access	Name	Data Type	Description	Default
11172	0	R	Alarm Monitor 36 Motor-side/load-side speed deviation	Integer32	Motor-side/load-side speed deviation at alarm occurrence	

PNU	Sub	Range	Units	EEP-ROM	Parameter
11172	0	80000000h to 7FFFFFFFh	r/min	Impossible	

(55) Alarm Monitor 37 Internal temperature of encoder (P11173)

The internal temperature of encoder at alarm occurrence is returned.

PNU	Sub	Access	Name	Data Type	Description	Default
11173	0	R	Alarm Monitor 37 Internal temperature of encoder	Integer32	Internal temperature of encoder at alarm occurrence	

PNU	Sub	Range	Units	EEP-ROM	Parameter
11173	0	80000000h to 7FFFFFFFh	°C	Impossible	

(56) Alarm Monitor 38 Settling time (P11174)

The settling time at alarm occurrence is returned.

PNU	Sub	Access	Name	Data Type	Description	Default
11174	0	R	Alarm Monitor 38 Settling time	Integer32	Settling time at alarm occurrence	

PNU	Sub	Range	Units	EEP-ROM	Parameter
11174	0	80000000h to 7FFFFFFFh	ms	Impossible	

20. PROFINET COMMUNICATION

(57) Alarm Monitor 39 Oscillation detection frequency (P11175)

The oscillation detection frequency at alarm occurrence is returned.

PNU	Sub	Access	Name	Data Type	Description	Default
11175	0	R	Alarm Monitor 39 Oscillation detection frequency	Integer32	Oscillation detection frequency at alarm occurrence	

PNU	Sub	Range	Units	EEP-ROM	Parameter
11175	0	80000000h to 7FFFFFFFh	Hz	Impossible	

(58) Alarm Monitor 40 Number of tough drive operations (P11176)

The number of tough drive operations at alarm occurrence is returned.

PNU	Sub	Access	Name	Data Type	Description	Default
11176	0	R	Alarm Monitor 40 Number of tough drive operations	Integer32	The number of tough drive operations at alarm occurrence	

PNU	Sub	Range	Units	EEP-ROM	Parameter
11176	0	80000000h to 7FFFFFFFh	number of times	Impossible	

(59) Alarm Monitor 45 Unit power consumption (P11181)

The unit power consumption at alarm occurrence is returned.

PNU	Sub	Access	Name	Data Type	Description	Default
11181	0	R	Alarm Monitor 45 Unit power consumption	Integer32	Unit power consumption at alarm occurrence	

PNU	Sub	Range	Units	EEP-ROM	Parameter
11181	0	80000000h to 7FFFFFFFh	W	Impossible	

(60) Alarm Monitor 46 Unit total power consumption (P11182)

The unit total power consumption at alarm occurrence is returned.

PNU	Sub	Access	Name	Data Type	Description	Default
11182	0	R	Alarm Monitor 46 Unit total power consumption	Integer32	Unit total power consumption at alarm occurrence	

PNU	Sub	Range	Units	EEP-ROM	Parameter
11182	0	80000000h to 7FFFFFFFh	Wh	Impossible	

(61) Alarm Monitor 47 Current position (P11183)

The current position at alarm occurrence is returned. In the indexer method, the value is fixed to "0".

PNU	Sub	Access	Name	Data Type	Description	Default
11183	0	R	Alarm Monitor 47 Current position	Integer32	Current position at alarm occurrence	

PNU	Sub	Range	Units	EEP-ROM	Parameter
11183	0	80000000h to 7FFFFFFFh	pos units	Impossible	

20. PROFINET COMMUNICATION

(62) Alarm Monitor 48 Command position (P11184)

The command position at alarm occurrence is returned. In the indexer method, the value is fixed to "0".

PNU	Sub	Access	Name	Data Type	Description	Default
11184	0	R	Alarm Monitor 48 Command position	Integer32	Command position at alarm occurrence	

PNU	Sub	Range	Units	EEP-ROM	Parameter
11184	0	80000000h to 7FFFFFFFh	pos units	Impossible	

(63) Alarm Monitor 49 Command remaining distance (P11185)

The command remaining distance at alarm occurrence is returned.

PNU	Sub	Access	Name	Data Type	Description	Default
11185	0	R	Alarm Monitor 49 Command remaining distance	Integer32	Command remaining distance at alarm occurrence	

PNU	Sub	Range	Units	EEP-ROM	Parameter
11185	0	80000000h to 7FFFFFFFh	pos units	Impossible	

(64) Alarm Monitor 50 Point table No./Program No./Station position No.. (P11186)

Point table No. or station position No. at alarm occurrence is returned.

PNU	Sub	Access	Name	Data Type	Description	Default
11186	0	R	Alarm Monitor 50 Point table No./Program No./Station position No..	Integer16	Point table No./station position No. at alarm occurrence	

PNU	Sub	Range	Units	EEP-ROM	Parameter
11186	0	00000000h to 000000FFh		Impossible	

20. PROFINET COMMUNICATION

20.9.3.5 Manufacturer Specific Control Objects

(1) External Output pin display (P11281)

The ON/OFF state of external output pins output from the driver can be read.

PNU	Sub	Access	Name	Data Type	Description	Default
11281	0	R	External Output pin display1	Integer32	External output pin status 1	

PNU	Sub	Range	Units	EEP-ROM	Parameter
11281	0	00000000h to 0000000Fh		Impossible	

The following shows the detail of External Output pin display1. When the output of the target pin is on, "1" is returned. When the output of the target pin is off, "0" is returned.

The values in the areas marked with diagonal lines at reading is undefined.

Bit	CN3 connector pin	Bit	CN3 connector pin	Bit	CN3 connector pin	Bit	CN3 connector pin
0	13	8		16		24	
1	15	9		17		25	
2	9	10		18		26	
3	8	11		19		27	
4		12		20		28	
5		13		21		29	
6		14		22		30	
7		15		23		31	

(2) Machine diagnostic status (P11296)

The current status of machine diagnostic can be obtained. Refer to section 8.9 for details.

PNU	Sub	Access	Name	Data Type	Description	Default
11296	0	R	Machine diagnostic status	Unsigned16	Machine diagnostic status	

PNU	Sub	Range	Units	EEP-ROM	Parameter
11296	0	Refer to the text.		Impossible	

20. PROFINET COMMUNICATION

The machine diagnostic status is returned. The description is as follows.

Bit	Description
0 to 3	Friction estimation status at forward rotation 0: Friction is being estimated. (normal) 1: Estimation is completed. (normal) 2: The servo motor may rotate in one direction too frequently. (warning) 3: The servo motor speed may too slow for friction estimation. (warning) 4: The change in the servo motor speed may be small for friction estimation. (warning) 5: The acceleration/deceleration time constants may be too short for friction estimation. (warning) 6: The operation time may not be enough. (warning) When warning conditions for 2 to 6 are met at the same time, the smaller number is returned. When an estimation is completed even though a warning has once occurred, the status changes to Estimation is completed.
4 to 7	Friction estimation status at reverse rotation 0: Friction is being estimated. (normal) 1: Estimation is completed. (normal) 2: The servo motor may rotate in one direction too frequently. (warning) 3: The servo motor speed may too slow for friction estimation. (warning) 4: The change in the servo motor speed may be small for friction estimation. (warning) 5: The acceleration/deceleration time constants may be too short for friction estimation. (warning) 6: The operation time may not be enough. (warning) When warning conditions for 2 to 6 are met at the same time, the smaller number is returned. When an estimation is completed even though a warning has once occurred, the status changes to Estimation is completed.
8 to 11	Vibration estimation status 0: During estimation 1: Estimation is completed.
12 to 15	(reserved) The value at reading is undefined.

(3) Static friction torque at forward rotation (P11297)

Static friction torque at forward rotation can be obtained. Refer to section 8.9 for details.

PNU	Sub	Access	Name	Data Type	Description	Default
11297	0	R	Static friction torque at forward rotation	Integer16	Static friction torque at forward rotation	

PNU	Sub	Range	Units	EEP-ROM	Parameter
11297	0	Refer to the text.	0.1%	Impossible	

(4) Dynamic friction torque at forward rotation (at rated speed) (P11298)

Dynamic friction torque at forward rotation (at rated speed) can be obtained. Refer to section 8.9 for details.

PNU	Sub	Access	Name	Data Type	Description	Default
11298	0	R	Dynamic friction torque at forward rotation (at rated speed)	Integer16	Dynamic friction torque at forward rotation (at rated speed)	

PNU	Sub	Range	Units	EEP-ROM	Parameter
11298	0	Refer to the text.	0.1%	Impossible	

20. PROFINET COMMUNICATION

(5) Static friction torque at reverse rotation (P11299)

Static friction torque at reverse rotation can be obtained. Refer to section 8.9 for details.

PNU	Sub	Access	Name	Data Type	Description	Default
11299	0	R	Static friction torque at reverse rotation	Integer16	Static friction torque at reverse rotation	

PNU	Sub	Range	Units	EEP-ROM	Parameter
11299	0	Refer to the text.	0.1%	Impossible	

(6) Dynamic friction torque at reverse rotation (at rated speed) (P11300)

Dynamic friction torque at reverse rotation (at rated speed) can be obtained. Refer to section 8.9 for details.

PNU	Sub	Access	Name	Data Type	Description	Default
11300	0	R	Dynamic friction torque at reverse rotation (at rated speed)	Integer16	Dynamic friction torque at reverse rotation (at rated speed)	

PNU	Sub	Range	Units	EEP-ROM	Parameter
11300	0	Refer to the text.	0.1%	Impossible	

(7) Oscillation frequency during motor stop (P11301)

Vibration frequency at stop/servo-lock can be obtained. Refer to section 8.9 for details.

PNU	Sub	Access	Name	Data Type	Description	Default
11301	0	R	Oscillation frequency during motor stop	Integer16	Oscillation frequency during motor stop	

PNU	Sub	Range	Units	EEP-ROM	Parameter
11301	0	Refer to the text.	1 Hz	Impossible	

(8) Vibration level during motor stop (P11302)

Vibration level at stop/servo-lock can be obtained. Refer to section 8.9 for details.

PNU	Sub	Access	Name	Data Type	Description	Default
11302	0	R	Vibration level during motor stop	Integer16	Vibration level during motor stop	

PNU	Sub	Range	Units	EEP-ROM	Parameter
11302	0	Refer to the text.	0.1%	Impossible	

(9) Oscillation frequency during motor operating (P11303)

Vibration frequency during operation can be obtained. Refer to section 8.9 for details.

PNU	Sub	Access	Name	Data Type	Description	Default
11303	0	R	Oscillation frequency during motor operating	Integer16	Oscillation frequency during motor operating	

PNU	Sub	Range	Units	EEP-ROM	Parameter
11303	0	Refer to the text.	1 Hz	Impossible	

20. PROFINET COMMUNICATION

(10) Vibration level during motor operating (P11304)

Vibration level during operation can be obtained. Refer to section 8.9 for details.

PNU	Sub	Access	Name	Data Type	Description	Default
11304	0	R	Vibration level during motor operating	Integer16	Vibration level during motor operating	

PNU	Sub	Range	Units	EEP-ROM	Parameter
11304	0	Refer to the text.	0.1%	Impossible	

(11) Control DI 1 (P11521)

Set control commands to control the driver. For details, refer to section 5.3.1 (2).

PNU	Sub	Access	Name	Data Type	Description	Default
11521	0	R/W	Control DI 1	Unsigned16	Control DI 1	

PNU	Sub	Range	Units	EEP-ROM	Parameter
11521	0	Refer to the text.		Impossible	

(12) Control DI 2 (P11522)

Set control commands to control the driver. For details, refer to section 5.3.1 (3).

PNU	Sub	Access	Name	Data Type	Description	Default
11522	0	R/W	Control DI 2	Unsigned16	Control DI 2	

PNU	Sub	Range	Units	EEP-ROM	Parameter
11522	0	Refer to the text.		Impossible	

(13) Control DI 3 (P11523)

Set control commands to control the driver. For details, refer to section 5.3.1 (4).

PNU	Sub	Access	Name	Data Type	Description	Default
11523	0	R/W	Control DI 3	Unsigned16	Control DI 3	

PNU	Sub	Range	Units	EEP-ROM	Parameter
11523	0	Refer to the text.		Impossible	

(14) Status DO 1 (P11537)

The servo status is returned. Refer to section 5.3.2 (3) for details.

PNU	Sub	Access	Name	Data Type	Description	Default
11537	0	R	Status DO 1	Unsigned16	Status DO 1	

PNU	Sub	Range	Units	EEP-ROM	Parameter
11537	0	Refer to the text.		Impossible	

(15) Status DO 2 (P11538)

The servo status is returned. Refer to section 5.3.2 (4) for details.

PNU	Sub	Access	Name	Data Type	Description	Default
11538	0	R	Status DO 2	Unsigned16	Status DO 2	

PNU	Sub	Range	Units	EEP-ROM	Parameter
11538	0	Refer to the text.		Impossible	

20. PROFINET COMMUNICATION

(16) Status DO 3 (P11539)

The servo status is returned. Refer to section 5.3.2 (5) for details.

PNU	Sub	Access	Name	Data Type	Description	Default
11539	0	R	Status DO 3	Unsigned16	Status DO 3	

PNU	Sub	Range	Units	EEP-ROM	Parameter
11539	0	Refer to the text.		Impossible	

(17) Status DO 5 (P11541)

The servo status is returned. Refer to section 5.3.2 (6) for details.

PNU	Sub	Access	Name	Data Type	Description	Default
11541	0	R	Status DO 5	Unsigned16	Status DO 5	

PNU	Sub	Range	Units	EEP-ROM	Parameter
11541	0	Refer to the text.		Impossible	

(18) Status DO 7 (P11543)

The servo status is returned. Refer to section 5.3.2 (7) for details.

PNU	Sub	Access	Name	Data Type	Description	Default
11543	0	R	Status DO 7	Unsigned16	Status DO 7	

PNU	Sub	Range	Units	EEP-ROM	Parameter
11543	0	Refer to the text.		Impossible	

(19) Velocity limit value (P11552)

Set the speed limit value for the profile torque mode (tq).

Unit: [0.01 r/min]

PNU	Sub	Access	Name	Data Type	Description	Default
11552	0	R/W	Velocity limit value	Unsigned32	Speed limit value	50000

PNU	Sub	Range	Units	EEP-ROM	Parameter
11552	0	00000000h to permissible speed	Vel units	Possible	PT67

(20) Motor rated speed (P11560)

The servo motor rated speed is returned.

Unit: [r/min]

PNU	Sub	Access	Name	Data Type	Description	Default
11560	0	R	Motor rated speed	Unsigned32	Servo motor rated speed	

PNU	Sub	Range	Units	EEP-ROM	Parameter
11560	0	00000000h to FFFFFFFFh	r/min	Impossible	

20. PROFINET COMMUNICATION

(21) Manufacturer Device Name 2 (P11568)

The model name of the _ driver is returned.

PNU	Sub	Access	Name	Data Type	Description	Default
11568	0	R	Manufacturer Device Name 2	VisibleString	Model name of the _ driver	

PNU	Sub	Range	Units	EEP-ROM	Parameter
11568	0			Impossible	

(22) Manufacturer Hardware Version 2 (P11569)

The hardware version of the _ driver is returned.

PNU	Sub	Access	Name	Data Type	Description	Default
11569	0	R	Manufacturer Hardware Version 2	VisibleString	Hardware version of the _ driver	

PNU	Sub	Range	Units	EEP-ROM	Parameter
11569	0			Impossible	

(23) Manufacturer Software Version 2 (P11570)

The software version of the _ driver is returned.

PNU	Sub	Access	Name	Data Type	Description	Default
11570	0	R	Manufacturer Software Version 2	VisibleString	Software version of the _ driver	

PNU	Sub	Range	Units	EEP-ROM	Parameter
11570	0			Impossible	

(24) Serial Number 2 (P11571)

The serial number of the _ driver is returned.

PNU	Sub	Access	Name	Data Type	Description	Default
11571	0	R	Serial Number 2	VisibleString	Serial number of the _ driver	

PNU	Sub	Range	Units	EEP-ROM	Parameter
11571	0			Impossible	

(25) User parameter configuration (P11572)

The parameters whose symbols are preceded by * are not automatically enabled. Writing "1EA5" to this parameter enables the parameters. This operation can be executed only when the upper side is other than the RUN state. Refer to section 8.14.1 for details.

PNU	Sub	Access	Name	Data Type	Description	Default
11572	0	R/W	User parameter configuration	Unsigned16	Parameter enabling	1

PNU	Sub	Range	Units	EEP-ROM	Parameter
11572	0	Refer to the text.		Impossible	

20. PROFINET COMMUNICATION

(26) Encoder status (P11573)

The encoder status is returned.

PNU	Sub	Access	Name	Data Type	Description	Default
11573	0	R	Encoder status1	Array [2]	Encoder status 1	
	1	R	Encoder status2	Unsigned32	Encoder status 2	

PNU	Sub	Range	Units	EEP-ROM	Parameter
11573	0	00000000h to 00000001h		Impossible	
	1	00000000h to 00000007h			

The following shows status of Sub 0 and 1.

Sub	Description
Encoder status1	This shows load side for the fully closed loop system and shows motor side or operation side for the others. Bit 0: Whether the driver is used in an absolute position detection system or not is outputted. (Incremental system: Off, Absolute position detection system: On)
Encoder status2	(Not supported)

(27) One-touch tuning mode (P11600)

Set this for one-touch tuning mode. Setting this starts one-touch tuning.

PNU	Sub	Access	Name	Data Type	Description	Default
11600	0	R/W	One-touch tuning mode	Unsigned8	One-touch tuning mode setting	

PNU	Sub	Range	Units	EEP-ROM	Parameter
11600	0	00h to 03h		Impossible	

The following settings are available.

Setting value	Description
0	During one-touch tuning stop
1	Basic mode
2	High mode
3	Low mode

(28) One-touch tuning status (P11601)

The one-touch tuning status is returned.

PNU	Sub	Access	Name	Data Type	Description	Default
11601	0	R	One-touch tuning status	Unsigned8	One-touch tuning status	

PNU	Sub	Range	Units	EEP-ROM	Parameter
11601	0	00h to 64h	%	Impossible	

20. PROFINET COMMUNICATION

(29) One-touch tuning Stop (P11602)

One-touch tuning stop command is issued. Writing "1EA5h" stops one-touch tuning.

PNU	Sub	Access	Name	Data Type	Description	Default
11602	0	W	One-touch tuning Stop	Unsigned16	Stop of one-touch tuning	

PNU	Sub	Range	Units	EEP-ROM	Parameter
11602	0	0000h, 1EA5h		Impossible	

(30) One-touch tuning Clear (P11603)

The parameter changed in one-touch tuning is returned to the value before the change.

PNU	Sub	Access	Name	Data Type	Description	Default
11603	0	W	One-touch tuning Clear	Unsigned16	The parameter changed in one-touch tuning is returned to the value before the change.	

PNU	Sub	Range	Units	EEP-ROM	Parameter
11603	0	0000h to 0001h		Impossible	

The following settings are available.

Setting value	Description
0000	Restores the initial value.
0001	Restores the value before one-touch tuning.

(31) One-touch tuning Error Code (P11604)

An error code of the one-touch tuning is returned.

PNU	Sub	Access	Name	Data Type	Description	Default
11604	0	R	One-touch tuning Error Code	Unsigned16	One-touch tuning error code	

PNU	Sub	Range	Units	EEP-ROM	Parameter
11604	0	0000h to C00Fh		Impossible	

The following error codes are available.

Value	Description
0000	Finished normally
C000	Tuning canceled
C001	Overshoot exceeded
C002	Servo-off during tuning
C003	Control mode error
C004	Time-out
C005	Inertia estimation failed
C00F	One-touch tuning disabled

20. PROFINET COMMUNICATION

(32) Torque limit value 2 (P11627)

The generated torque at a servo motor stop in the indexer method can be limited. Set this parameter to "0" to generate no torque.

PNU	Sub	Access	Name	Data Type	Description	Default
11627	0	R/W	Torque limit value 2	Unsigned16	Torque limit value 2	10000

PNU	Sub	Range	Units	EEP-ROM	Parameter
11627	0	0000h to 2710h	Per thousand of rated torque	Impossible	

20.9.3.6 PDS Control Objects

(1) Error code (P24639)

The latest error No. that occurred after the power on is returned.

PNU	Sub	Access	Name	Data Type	Description	Default
24639	0	R	Error code	Unsigned16	The latest error No. that occurred after the power on	0

PNU	Sub	Range	Units	EEP-ROM	Parameter
24639	0	0000h to FFFFh		Impossible	

(2) Controlword (P24640)

Set control commands to control the driver. Refer to section 5.3.1 for details.

PNU	Sub	Access	Name	Data Type	Description	Default
24640	0	R/W	Controlword	Unsigned16	Controlword	0

PNU	Sub	Range	Units	EEP-ROM	Parameter
24640	0	Refer to the text.		Impossible	

(3) Statusword (P24641)

The servo status is returned. Refer to section 5.3.2 for details.

PNU	Sub	Access	Name	Data Type	Description	Default
24641	0	R	Statusword	Unsigned16	Statusword	

PNU	Sub	Range	Units	EEP-ROM	Parameter
24641	0	Refer to the text.		Impossible	

(4) Quick stop option code (P24666)

Set how to decelerate the servo motor to a stop at Quick Stop reception. Refer to section 8.10 for details.

PNU	Sub	Access	Name	Data Type	Description	Default
24666	0	R/W	Quick stop option code	Integer16	How to decelerate the servo motor to a stop at Quick Stop reception	2

PNU	Sub	Range	Units	EEP-ROM	Parameter
24666	0	0002h to 0002h		possible	PT68

20. PROFINET COMMUNICATION

(5) Halt option code (P24669)

Set how to decelerate the servo motor to a stop at Halt reception. Refer to section 8.11 for details.

PNU	Sub	Access	Name	Data Type	Description	Default
24669	0	R/W	Halt option code	Integer16	How to decelerate the servo motor to a stop at Halt reception	1

PNU	Sub	Range	Units	EEP-ROM	Parameter
24669	0	0001h to 0001h		possible	PT68

(6) Modes of operation (P24672)

PNU	Sub	Access	Name	Data Type	Description	Default
24672	0	R/W	Modes of operation	Integer8	Set the control mode.	0

PNU	Sub	Range	Units	EEP-ROM	Parameter
24672	0	Refer to the following table.		Impossible	

Setting value	Description
0	No mode change/No mode assigned
1	Profile position mode (pp)
3	Profile velocity mode (pv)
4	Profile torque mode (tq)
6	Homing mode (hm)
-100	Jog mode (jg)
-101	Point table mode (pt)
-103	Indexer mode (idx)

(7) Modes of operation display (P24673)

PNU	Sub	Access	Name	Data Type	Description	Default
24673	0	R	Modes of operation display	Integer8	The current control mode is returned.	Refer to the text.

PNU	Sub	Range	Units	EEP-ROM	Parameter
24673	0	Refer to the following table.		Impossible	

Setting value	Description
0	No mode assigned
1	Profile position mode (pp)
3	Profile velocity mode (pv)
4	Profile torque mode (tq)
6	Homing mode (hm)
-100	Jog mode (jg)
-101	Point table mode (pt)
-103	Indexer mode (idx)

20. PROFINET COMMUNICATION

(8) Supported drive modes (P25858)

PNU	Sub	Access	Name	Data Type	Description	Default
25858	0	R	Supported drive modes	Unsigned32	The supported control mode is returned.	Refer to the text.

PNU	Sub	Range	Units	EEP-ROM	Parameter
25858	0	Refer to the following table.		Impossible	

Bit	Description
0	Profile position mode (pp)
2	Profile velocity mode (pv)
3	Profile torque mode (tq)
5	Homing mode (hm)
16	Jog mode (jg)
17	Point table mode (pt)
19	Indexer mode (idx)

20. PROFINET COMMUNICATION

20.9.3.7 Position Control Function Objects

(1) Position actual internal value (P24675)

The current position is returned.

PNU	Sub	Access	Name	Data Type	Description	Default
24675	0	R	Position actual internal value	Integer32	Current position	

PNU	Sub	Range	Units	EEP-ROM	Parameter
24675	0	80000000h to 7FFFFFFFh	inc	Impossible	

(2) Position actual value (P24676)

The current position in the command unit is returned.

In the indexer method, "0" is returned.

PNU	Sub	Access	Name	Data Type	Description	Default
24676	0	R	Position actual value	Integer32	Current position in the command unit	

PNU	Sub	Range	Units	EEP-ROM	Parameter
24676	0	80000000h to 7FFFFFFFh	pos units	Impossible	

(3) Following error window (P24677)

In the profile position mode (pp), point table mode (pt), Jog mode (jg) and indexer mode (idx), when the time set with Following error time out (P24678) has elapsed with the number of droop pulses exceeding the setting value of this object, Bit 13 of Statusword (P24641) turns on. When "FFFFFFFh" is set, Bit 13 of Statusword (P24641) is always off.

PNU	Sub	Access	Name	Data Type	Description	Default
24677	0	R/W	Following error window	Unsigned32	Position error threshold for judging Following error	00C00000h

PNU	Sub	Range	Units	EEP-ROM	Parameter
24677	0	00000000h to FFFFFFFFh	pos units	possible	PC67/PC68

(4) Following error time out (P24678)

Refer to Following error window (P24677).

PNU	Sub	Access	Name	Data Type	Description	Default
24678	0	R/W	Following error time out	Unsigned16	Following error judging time	10

PNU	Sub	Range	Units	EEP-ROM	Parameter
24678	0	0000h to FFFFh	ms	possible	PC69

20. PROFINET COMMUNICATION

(5) Position window (P24679)

In the profile position mode (pp), point table mode (pt) or JOG operation mode (jg), when the time set with Position windows time (P24680) has elapsed with the number of droop pulses equal to or lower than the setting value of this object, Bit 10 of Statusword (P24641) is turned on. When "FFFFFFFFh" is set, Bit 10 of Statusword (P24641) is always on.

PNU	Sub	Access	Name	Data Type	Description	Default
24679	0	R/W	Position window	Unsigned32	Position error threshold for judging Target reached	100

PNU	Sub	Range	Units	EEP-ROM	Parameter
24679	0	00000000h to FFFFFFFFh	pos units	possible	PC70

(6) Position window time (P24680)

Refer to Position window (P24679).

PNU	Sub	Access	Name	Data Type	Description	Default
24680	0	R/W	Position window time	Unsigned16	Target reached judgment time	10

PNU	Sub	Range	Units	EEP-ROM	Parameter
24680	0	0000h to FFFFh	ms	Possible	PC71

(7) Positioning option code (P24818)

PNU	Sub	Access	Name	Data Type	Description	Default
24818	0	R/W	Positioning option code	Unsigned16	Positioning option code	0000h

PNU	Sub	Range	Units	EEP-ROM	Parameter
24818	0	0000h to 00C0h	-	Possible	PT03

Set the profile position mode. The description of this object is as follows.

Bit	Description	Default
0 to 1	00b: The positioning is performed with the relative position from the internal absolute target position. 01b: The positioning is performed with the relative position from Position demand actual value (P24828). (Not compatible) (Note) 10b: The positioning is performed with the relative position from Position actual value (P24676). (Not compatible) (Note) 11b: reserved	00b
2 to 3	00b: A new value of Target position (P24698), Profile velocity (P24705), and Acceleration are promptly reflected. 01b: The current positioning continues to reach the target position. Then a new setting of Target position (P24698), Profile velocity (P24705), and Acceleration is reflected. (Not compatible) (Note) 10b: reserved 11b: reserved	00b
4 to 5	Reserved	0
6 to 7	00b: The servo motor rotates to the target position in a direction specified with a sign of the position data. 01b: The servo motor rotates in the address decreasing direction regardless of the sign of the position data. 10b: The servo motor rotates in the address increasing direction regardless of the sign of the position data. 11b: The servo motor rotates from the current position to the target position in the shorter direction. If the distances from the current position to the target position are the same for CCW and CW, the servo motor rotates in the CCW direction.	00b
8 to 15	Reserved	0

Note. This is not supported by the driver.

20. PROFINET COMMUNICATION

(8) Following error actual value (P24820)

The droop pulses are returned.

PNU	Sub	Access	Name	Data Type	Description	Default
24820	0	R	Following error actual value	Integer32	Droop pulses	

PNU	Sub	Range	Units	EEP-ROM	Parameter
24820	0	80000000h to 7FFFFFFFh	pos units	Impossible	

(9) Control effort (P24826)

The speed command is returned.

Unit: [0.01 r/min]

PNU	Sub	Access	Name	Data Type	Description	Default
24826	0	R	Control effort	Integer32	Speed command	

PNU	Sub	Range	Units	EEP-ROM	Parameter
24826	0	80000000h to 7FFFFFFFh	vel units	Impossible	

20.9.3.8 Profile Velocity Mode Objects

(1) Velocity demand value (P24683)

The speed command is returned.

Unit: [0.01 r/min]

PNU	Sub	Access	Name	Data Type	Description	Default
24683	0	R	Velocity demand value	Integer32	Speed command	

PNU	Sub	Range	Units	EEP-ROM	Parameter
24683	0	80000000h to 7FFFFFFFh	vel units	Impossible	

(2) Velocity actual value (P24684)

The current speed is returned.

Unit: [0.01 r/min]

PNU	Sub	Access	Name	Data Type	Description	Default
24684	0	R	Velocity actual value	Integer32	Current speed	

PNU	Sub	Range	Units	EEP-ROM	Parameter
24684	0	80000000h to 7FFFFFFFh	vel units	Impossible	

20. PROFINET COMMUNICATION

(3) Velocity window (P24685)

In the profile velocity mode (pv), when the time set with Velocity window time (P24686) has elapsed with the current speed equal to or lower than the setting value of this parameter, Bit 10 of Statusword (P24641) is turned on.

Unit: [0.01 r/min]

PNU	Sub	Access	Name	Data Type	Description	Default
24685	0	R/W	Velocity window	Unsigned16	Speed error threshold for judging Target reached	2000

PNU	Sub	Range	Units	EEP-ROM	Parameter
24685	0	0000h to FFFFh	vel units	Possible	PC72

(4) Velocity window time (P24686)

Refer to Velocity window (P24685).

PNU	Sub	Access	Name	Data Type	Description	Default
24686	0	R/W	Velocity window time	Unsigned16	Target reached judgment time	10

PNU	Sub	Range	Units	EEP-ROM	Parameter
24686	0	0000h to FFFFh	ms	Possible	PC77

(5) Velocity threshold (P24687)

In the profile velocity mode (pv), when the time set with Velocity threshold time (P24688) has elapsed with the current speed exceeding the setting value of this PROFIdrive parameter, Bit 12 of Statusword (P24641) is turned off.

Unit: [0.01 r/min]

PNU	Sub	Access	Name	Data Type	Description	Default
24687	0	R/W	Velocity threshold	Unsigned16	Zero speed threshold for judging Speed	5000

PNU	Sub	Range	Units	EEP-ROM	Parameter
24687	0	0000h to FFFFh	vel units	Possible	PC65

(6) Velocity threshold time (P24688)

Refer to Velocity threshold (P24687).

PNU	Sub	Access	Name	Data Type	Description	Default
24688	0	R/W	Velocity threshold time	Unsigned16	Speed judgment time	10

PNU	Sub	Range	Units	EEP-ROM	Parameter
24688	0	0000h to FFFFh	ms	Possible	PC66

(7) Target velocity (P24831)

Set the speed command used in the profile velocity mode (pv).

Unit: [0.01 r/min]

PNU	Sub	Access	Name	Data Type	Description	Default
24831	0	R/W	Target velocity	Integer32	Speed command	0

PNU	Sub	Range	Units	EEP-ROM	Parameter
24831	0	80000000h to 7FFFFFFFh	vel units	Impossible	

20. PROFINET COMMUNICATION

20.9.3.9 Profile Torque Mode Objects

(1) Target torque (P24689)

Set the torque command used in the profile torque mode (tq).

PNU	Sub	Access	Name	Data Type	Description	Default
24689	0	R/W	Target torque	Integer16	Torque command	0

PNU	Sub	Range	Units	EEP-ROM	Parameter
24689	0	8000h to 7FFFh	Per thousand of rated torque	Impossible	

(2) Max torque (P24690)

The maximum torque of the servo motor is returned. The values notified by this PROFIdrive parameter are the maximum current and feedback value and may not match the maximum torque mentioned in "Servo Motor Instruction Manual (Vol. 3)".

PNU	Sub	Access	Name	Data Type	Description	Default
24690	0	R/W	Max torque	Unsigned16	Maximum torque	

PNU	Sub	Range	Units	EEP-ROM	Parameter
24690	0	0000h to FFFFh	Per thousand of rated torque	Impossible	

(3) Torque demand (P24692)

The torque command is returned.

PNU	Sub	Access	Name	Data Type	Description	Default
24692	0	R	Torque demand	Integer16	Torque command	

PNU	Sub	Range	Units	EEP-ROM	Parameter
24692	0	8000h to 7FFFh	Per thousand of rated torque	Impossible	

(4) Torque actual value (P24695)

The current torque is returned.

PNU	Sub	Access	Name	Data Type	Description	Default
24695	0	R	Torque actual value	Integer16	Current torque	

PNU	Sub	Range	Units	EEP-ROM	Parameter
24695	0	8000h to 7FFFh	Per thousand of rated torque	Impossible	

20. PROFINET COMMUNICATION

(5) Torque slope (P24711)

Set the variation per second of the torque command used in the profile torque mode. When 0 is set, the setting value is invalid and the torque command is input with step input.

PNU	Sub	Access	Name	Data Type	Description	Default
24711	0	R/W	Torque slope	Unsigned32	Variation of the torque command per second	0000000h

PNU	Sub	Range	Units	EEP-ROM	Parameter
24711	0	0000000h to 00989680h (10000000)	Per thousand of rated torque per second	Possible	PT53

(6) Torque profile type (P24712)

Set the torque command pattern. Refer to section 6.5 (1) for details.

PNU	Sub	Access	Name	Data Type	Description	Default
24712	0	R/W	Torque profile type	Integer16	Torque command pattern	0

PNU	Sub	Range	Units	EEP-ROM	Parameter
24712	0	0000h to 0000h		Impossible	

(7) Positive torque limit value (P24800)

You can limit the torque generated by the servo motor. Set the limit value of the torque of the servo motor in the CCW power running or CW regeneration, in the positive direction power running or negative direction regeneration. Set this object to 0 to generate no torque.

PNU	Sub	Access	Name	Data Type	Description	Default
24800	0	R/W	Positive torque limit value	Unsigned16	Forward rotation torque limit	10000

PNU	Sub	Range	Units	EEP-ROM	Parameter
24800	0	0000h to 2710h	Per thousand of rated torque	Possible	PA11 (POL disabled) PA12 (POL enabled)

(8) Negative torque limit value (P24801)

You can limit the torque generated by the servo motor. Set the limit value of the torque of the servo motor in the CW power running or CCW regeneration, in the negative direction power running or positive direction regeneration. Set this object to 0 to generate no torque.

PNU	Sub	Access	Name	Data Type	Description	Default
24801	0	R/W	Negative torque limit value	Unsigned16	Reverse rotation torque limit	10000

PNU	Sub	Range	Units	EEP-ROM	Parameter
24801	0	0000h to 2710h	Per thousand of rated torque	Possible	PA12 (POL disabled) PA11 (POL enabled)

20. PROFINET COMMUNICATION

20.9.3.10 Profile Position Mode Objects

(1) Target position (P24698)

Set the position command used in the profile position mode (pp). The settable values vary depending on the setting of command unit [Pr. PT01] (_ x _).

PNU	Sub	Access	Name	Data Type	Description	Default
24698	0	R/W	Target position	Integer32	Position command	

PNU	Sub	Range	Units	EEP-ROM	Parameter
24698	0	Refer to the text.	pos units	Impossible	

[Pr. PT01] setting	Range
_ 0 _ (mm)	FFF0BDC1h to 000F423Fh (-999999 to 999999)
_ 1 _ (inch)	FFF0BDC1h to 000F423Fh (-999999 to 999999)
_ 2 _ (degree)	FFFA81C0h to 00057E40h (-360000 to 360000)
_ 3 _ (pulse)	FFF0BDC1h to 000F423Fh (-999999 to 999999)

(2) Position range limit (P24699)

PNU	Sub	Access	Name	Data Type	Description	Default
24699	0	R/W	Min position range limit	Array [2]	Minimum value of the position range limit	
	1	R/W	Max position range limit	Integer32	Maximum value of the position range limit	

PNU	Sub	Range	Units	EEP-ROM	Parameter
24699	0	Refer to the text.	pos units	Impossible	
	1				

No value can be written because Position range limit (P24699) is set automatically with the control mode and [Pr. PT01]. Writing a value will trigger Error No. 02h (Low or high limit exceeded).

Control mode	[Pr. PT01] setting	Range
Profile mode	_ 0 _ (mm)	80000000h to 7FFFFFFFh (-2147483648 to 2147483647)
	_ 1 _ (inch)	80000000h to 7FFFFFFFh (-2147483648 to 2147483647)
	_ 2 _ (degree)	00000000h to 00057E3Fh (0 to 359999)
	_ 3 _ (pulse)	80000000h to 7FFFFFFFh (-2147483648 to 2147483647)
Point table method	_ 0 _ (mm)	80000000h to 7FFFFFFFh (-2147483648 to 2147483647)
	_ 1 _ (inch)	80000000h to 7FFFFFFFh (-2147483648 to 2147483647)
	_ 3 _ (pulse)	80000000h to 7FFFFFFFh (-2147483648 to 2147483647)
Indexer method		0 to set value in [Pr. PT28] -1

20. PROFINET COMMUNICATION

(3) Software position limit (P24701)

Set the range for limiting the command position. Target position (P24698) is limited within the range between Min position limit (P24701.0) and Max position limit (P24701.1). When the set value of Min position limit (P24701.0) is equal to or greater than the set value of Max position limit (P24701.1), the function of Software position limit (P24701) is disabled.

In the indexer method, this function is disabled.

PNU	Sub	Access	Name	Data Type	Description	Default
24701	0	R/W	Min position limit	Array [2] Integer32	Lower software position limit	0
	1	R/W	Max position limit		Upper software position limit	

PNU	Sub	Range	Units	EEP-ROM	Parameter
24701	0	80000000h to 7FFFFFFFh	pos units	Possible	PT17/PT18
	1				PT15/PT16

(4) Max profile velocity (P24703)

Set the speed limit value for the profile position mode (pp), the profile velocity mode (pv), the jog mode (jg), and the indexer mode (idx). When a value exceeding this PROFIdrive parameter is set to Target velocity (P24831) or Profile velocity (P24705), the speed is limited with the value of this PROFIdrive parameter.

PNU	Sub	Access	Name	Data Type	Description	Default
24703	0	R/W	Max profile velocity	Unsigned32	Speed limit value	2000000

PNU	Sub	Range	Units	EEP-ROM	Parameter
24703	0	00000000h to 001E8480h (2000000)	vel units	Possible	PT66

(5) Max motor speed (P24704)

The maximum speed (value of instantaneous permissible speed) of the servo motor is returned.

Operation cannot be performed at a speed exceeding the speed set with this PROFIdrive parameter.

Unit: [r/min]

PNU	Sub	Access	Name	Data Type	Description	Default
24704	0	R/W	Max motor speed	Unsigned32	Servo motor maximum speed	

PNU	Sub	Range	Units	EEP-ROM	Parameter
24704	0	00000000h to FFFFFFFFh	Refer to the text.	Impossible	

(6) Profile velocity (P24705)

Set the command speed in the profile position mode (pp), the jog mode (jg), and the indexer mode (idx).

Set a value within the range between 0 and permissible speed.

Unit: [r/min]

PNU	Sub	Access	Name	Data Type	Description	Default
24705	0	R/W	Profile velocity	Unsigned32	Speed command	10000

PNU	Sub	Range	Units	EEP-ROM	Parameter
24705	0	Refer to the text.	vel units	Possible	PT65

20. PROFINET COMMUNICATION

(7) Profile acceleration (P24707)

Set the acceleration time constant in the profile position mode (pp), the profile velocity mode (pv), the jog mode (jg), and the indexer mode (idx). Set a time for the servo motor to reach the rated speed. The settable values vary depending on the control mode.

PNU	Sub	Access	Name	Data Type	Description	Default
24707	0	R/W	Profile acceleration	Unsigned32	Acceleration time constant	0

PNU	Sub	Range	Units	EEP-ROM	Parameter
24707	0	Refer to the text.	ms	Possible	PT49

Control mode	Range
Profile position mode (pp)	0 to 20000
Profile velocity mode (pv)	0 to 50000
Jog mode (jg)	0 to 20000
Indexer mode (idx)	0 to 20000

(8) Profile deceleration (P24708)

Set the deceleration time constant in the profile position mode (pp), the profile velocity mode (pv), the jog mode (jg), and the indexer mode (idx). Set a time for the servo motor to stop from the rated speed. The settable values vary depending on the control mode.

PNU	Sub	Access	Name	Data Type	Description	Default
24708	0	R/W	Profile deceleration	Unsigned32	Deceleration time constant	0

PNU	Sub	Range	Units	EEP-ROM	Parameter
24708	0	Refer to the text.	ms	Possible	PT50

Control mode	Range
Profile position mode (pp)	0 to 20000
Profile velocity mode (pv)	0 to 50000
Jog mode (jg)	0 to 20000
Indexer mode (idx)	0 to 20000

(9) Quick stop deceleration (P24709)

Set a deceleration time constant for the Quick stop function. Set a time for the servo motor to stop from the rated speed. When 0 is set, the operation is performed with 100 ms.

PNU	Sub	Access	Name	Data Type	Description	Default
24709	0	R/W	Quick stop deceleration	Unsigned32	Deceleration time constant	100

PNU	Sub	Range	Units	EEP-ROM	Parameter
24709	0	00000000h to 00004E20h (20000)	ms	Possible	PC24

20. PROFINET COMMUNICATION

(10) Motion profile type (P24710)

Set the acceleration/deceleration pattern in the profile position mode (pp). The description is as follows.

PNU	Sub	Access	Name	Data Type	Description	Default
24710	0	R/W	Motion profile type	Integer16	Acceleration/deceleration pattern generation	-1

PNU	Sub	Range	Units	EEP-ROM	Parameter
24710	0	FFFFh to FFFFh		Impossible	

Acceleration/deceleration type selection

Setting value	Description
-1	S-pattern
0	Linear ramp (not compatible) (Note)
1	Sin ² ramp (not compatible) (Note)
2	Jerk-free ramp (not compatible) (Note)
3	Jerk-limited ramp (not compatible) (Note)

Note. This is not supported by the driver.

20. PROFINET COMMUNICATION

20.9.3.11 Homing Mode Objects

(1) Home offset (P24700)

The home position is returned. Only reading the value is available. Do not perform writing because doing so causes an error.

PNU	Sub	Access	Name	Data Type	Description	Default
24700	0	R/W	Home offset	Integer32	Home position	-1

PNU	Sub	Range	Units	EEP-ROM	Parameter
24700	0	80000000h to 7FFFFFFFh	pos units	Possible	

(2) Homing method (P24728)

Set a home position return type. Refer to section 6.6 (4) for the settable values.

PNU	Sub	Access	Name	Data Type	Description	Default
24728	0	R/W	Homing method	Integer8	Home position return type	37

PNU	Sub	Range	Units	EEP-ROM	Parameter
24728	0	D5h (-43) to 25h (37)		Possible	PT45

(3) Homing speeds (P24729)

Set the servo motor speed at home position return.

Set the servo motor speed at home position return for Speed during search for switch (P24729.0).

Unit: [0.01 r/min]

Set the creep speed after proximity dog at home position return for Speed during search for zero (P24729.1).

Unit: [0.01 r/min]

PNU	Sub	Access	Name	Data Type	Description	Default
24729	0	R/W	Speed during search for switch	Array [2] Integer32	Home position return speed	10000
	1	R/W	Speed during search for zero		Creep speed	1000

PNU	Sub	Range	Units	EEP-ROM	Parameter
24729	0	00000000h to permissible speed	vel units	Possible	PT05
	1				PT06

(4) Homing acceleration (P24730)

Set the acceleration/deceleration time constants at home position return. Set a time for the servo motor to reach the rated speed.

PNU	Sub	Access	Name	Data Type	Description	Default
24730	0	R/W	Homing acceleration	Integer32	Home position return acceleration/deceleration time constant	0

PNU	Sub	Range	Units	EEP-ROM	Parameter
24730	0	00000000h to 00004E20h (20000)	ms	Possible	PT56

20. PROFINET COMMUNICATION

(5) Supported homing method (P24803)

The supported home position return type is returned.

(a) Profile mode/point table method

PNU	Sub	Access	Name	Data Type	Description	Default
24803	0	R	1st supported homing method	Array [39] Integer8	1st supported homing method	37
	1	R	2nd supported homing method		2nd supported homing method	35
	2	R	3rd supported homing method		3rd supported homing method	34
	3	R	4th supported homing method		4th supported homing method	33
	4	R	5th supported homing method		5th supported homing method	28
	5	R	6th supported homing method		6th supported homing method	27
	6	R	7th supported homing method		7th supported homing method	24
	7	R	8th supported homing method		8th supported homing method	23
	8	R	9th supported homing method		9th supported homing method	22
	9	R	10th supported homing method		10th supported homing method	21
	10	R	11th supported homing method		11th supported homing method	20
	11	R	12th supported homing method		12th supported homing method	19
	12	R	13th supported homing method		13th supported homing method	12
	13	R	14th supported homing method		14th supported homing method	11
	14	R	15th supported homing method		15th supported homing method	8
	15	R	16th supported homing method		16th supported homing method	7
	16	R	17th supported homing method		17th supported homing method	6
	17	R	18th supported homing method		18th supported homing method	5
	18	R	19th supported homing method		19th supported homing method	4
	19	R	20th supported homing method		20th supported homing method	3
	20	R	21st supported homing method		21st supported homing method	-1
	21	R	22nd supported homing method		22nd supported homing method	-2
	22	R	23rd supported homing method		23rd supported homing method	-3
	23	R	24th supported homing method		24th supported homing method	-4
	24	R	25th supported homing method		25th supported homing method	-6
	25	R	26th supported homing method		26th supported homing method	-7
	26	R	27th supported homing method		27th supported homing method	-8
	27	R	28th supported homing method		28th supported homing method	-9

20. PROFINET COMMUNICATION

PNU	Sub	Access	Name	Data Type	Description	Default
24803	28	R	29th supported homing method	Array [39] Integer8	29th supported homing method	-10
	29	R	30th supported homing method		30th supported homing method	-11
	30	R	31st supported homing method		31st supported homing method	-33
	31	R	32nd supported homing method		32nd supported homing method	-34
	32	R	33rd supported homing method		33rd supported homing method	-36
	33	R	34th supported homing method		34th supported homing method	-38
	34	R	35th supported homing method		35th supported homing method	-39
	35	R	36th supported homing method		36th supported homing method	-40
	36	R	37th supported homing method		37th supported homing method	-41
	37	R	38th supported homing method		38th supported homing method	-42
	38	R	39th supported homing method		39th supported homing method	-43

PNU	Sub	Range	Units	EEP-ROM	Parameter
24803	0	25h (37)		Impossible	
	1	23h (35)			
	2	22h (34)			
	3	21h (33)			
	4	1Ch (28)			
	5	1Bh (27)			
	6	18h (24)			
	7	17h (23)			
	8	16h (22)			
	9	15h (21)			
	10	14h (20)			
	11	13h (19)			
	12	0Ch (12)			
	13	0Bh (11)			
	14	08h (8)			
	15	07h (7)			
	16	06h (6)			
	17	05h (5)			
	18	04h (4)			
	19	03h (3)			
	20	FFh (-1)			
	21	FEh (-2)			
	22	FDh (-3)			
	23	FCh (-4)			
	24	FAh (-6)			
	25	F9h (-7)			
	26	F8h (-8)			
	27	F7h (-9)			
	28	F6h (-10)			
	29	F5h (-11)			
	30	DFh (-33)			
	31	DEh (-34)			

20. PROFINET COMMUNICATION

PNU	Sub	Range	Units	EEP-ROM	Parameter
24803	32	DCh (-36)		Impossible	
	33	DAh (-38)			
	34	D9h (-39)			
	35	D8h (-40)			
	36	D7h (-41)			
	37	D6h (-42)			
	38	D5h (-43)			

(b) Indexer method

PNU	Sub	Access	Name	Data Type	Description	Default
24803	0	R	1st supported homing method	Array [5] Integer8	1st supported homing method	37
	1	R	2nd supported homing method		2nd supported homing method	35
	2	R	3rd supported homing method		3rd supported homing method	-1
	3	R	4th supported homing method		4th supported homing method	-3
	4	R	5th supported homing method		5th supported homing method	-33

PNU	Sub	Range	Units	EEP-ROM	Parameter
24803	0	25h (37)		Impossible	
	1	23h (35)			
	2	FFh (-1)			
	3	FDh (-3)			
	4	DFh (-33)			

20. PROFINET COMMUNICATION

20.9.3.12 Point Table Mode Objects

(1) Target point table (P11616)

In the point table mode (pt), specify the point table No. to execute. In the indexer mode (idx), set the next station No to execute. The settable values vary depending on the control mode.

PNU	Sub	Access	Name	Data Type	Description	Default
11616	0	R/W	Target point table	Integer16	Refer to the text.	0

PNU	Sub	Range	Units	EEP-ROM	Parameter
11616	0	Refer to the text.		Impossible	

Control mode	Range
Point table mode (pt)	FFFFh to 00FFh (-1 to 255)
Indexer mode (idx)	0000h to 00FEh (0 to 254)

(2) Point demand value (P11624)

In the point table mode (pt), the currently specified point table No. is returned. In the indexer mode (idx), the currently specified next station No. is returned. The returned values vary depending on the control mode.

PNU	Sub	Access	Name	Data Type	Description	Default
11624	0	R	Point demand value	Integer16	Refer to the text.	0

PNU	Sub	Range	Units	EEP-ROM	Parameter
11624	0	Refer to the text.		Impossible	

Control mode	Range
Point table mode (pt)	FFFFh to 00FFh (-1 to 255)
Indexer mode (idx)	0000h to 00FEh (0 to 254)

(3) Point actual value (P11625)

In the point table mode (pt), the completed point table No. is returned. In the indexer mode (idx), the completed station No. is returned. The returned values vary depending on the control mode.

PNU	Sub	Access	Name	Data Type	Description	Default
11625	0	R	Point actual value	Integer16	Refer to the text.	0

PNU	Sub	Range	Units	EEP-ROM	Parameter
11625	0	Refer to the text.		Impossible	

Control mode	Range
Point table mode (pt)	FFFFh to 00FFh (-1 to 255)
Indexer mode (idx)	0000h to 00FEh (0 to 254)

20. PROFINET COMMUNICATION

(4) Point table (P10241 to P10495)

Register the positioning data to the point table.

PNU	Sub	Access	Name	Data Type	Description	Default
10241 to 10495	0	R/W	Point data	Integer32	Position data	0
	1	R/W	Speed	Integer32	Speed	0
	2	R/W	Acceleration	Integer32	Acceleration time constant	0
	3	R/W	Deceleration	Integer32	Deceleration time constant	0
	4	R/W	Dwell	Integer32	Dwell	0
	5	R/W	Auxiliary	Integer32	Auxiliary function	0
	6	R/W	M code	Integer32	M code	0

PNU	Sub	Range	Units	EEP-ROM	Parameter
10241 to 10495	0	Refer to the text.	pos units	Possible	
	1	00000000h to instantaneous permissible speed	vel units		
	2	00000000h to 00004E20h (0 to 20000)	ms		
	3	00000000h to 00004E20h (0 to 20000)	ms		
	4	00000000h to 00004E20h (0 to 20000)	ms		
	5	00000000h to 00000003h, 00000008h to 0000000Bh (0 to 3, 8 to 11)			
	6	00000000h to 00000063h (0 to 99)			

The settable values in Point data vary depending on the setting of [Pr. PT01].

PT01	Range
_ 0 _ _ [mm]	FFF0BDC1h to 000F423Fh (-999999 to 999999)
_ 1 _ _ [inch]	FFF0BDC1h to 000F423Fh (-999999 to 999999)
_ 3 _ _ [pulse]	FFF0BDC1h to 000F423Fh (-999999 to 999999)

When "1" or "3" is set in Auxiliary of the point table No. 255, bit 6 in the Point table error factor (P10819: 1) turns on and an error occurs. The following shows the description of the values to be set in Auxiliary.

Setting value	Point table command method	Description
0	Absolute value command method	Automatic operation for a selected point table is performed.
1		Automatic continuous operation is performed to the next point table without a stop.
8		Automatic continuous operation is performed without a stop to the point table selected at start-up.
9		Automatic continuous operation is performed without stopping a point table No. 1.
2	Incremental value command method	Automatic operation for a selected point table is performed.
3		Automatic continuous operation is performed to the next point table without a stop.
10		Automatic continuous operation is performed to the point table selected at the start.
11		Automatic continuous operation is performed without stopping a point table No. 1.

20. PROFINET COMMUNICATION

(5) Point table error (P10819)

The point table No. in which a point table error has occurred is returned with Point table error No.

(P10819: 1). The error factor of the corresponding point table in which a point table error has occurred is returned with Point table error factor (P10819: 2).

PNU	Sub	Access	Name	Data Type	Description	Default
10819	0	R	Point table error No.	Unsigned32	Point table error number	0
	1	R	Point table error factor	Unsigned32	Point table error factor	0

PNU	Sub	Range	Units	EEP-ROM	Parameter
10819	0	00000000h to 000000FFh (0 to 255)		Impossible	
	1	00000000h to 000000FDh			

The following shows the details of the error factor.

Bit	Description
0	0: No error 1: Target position error
1	reserved
2	0: No error 1: Speed error
3	0: No error 1: Acceleration time constant error
4	0: No error 1: Deceleration time constant error
5	0: No error 1: Dwell time error
6	0: No error 1: Auxiliary function error
7	0: No error 1: M code error
8 to 31	reserved

(6) M code actual value (P11626)

The completed M code of the point table is returned. In the indexer method, "0" is returned.

PNU	Sub	Access	Name	Data Type	Description	Default
11626	0	R	M code actual value	Unsigned8	Completed M code of the point table	0

PNU	Sub	Range	Units	EEP-ROM	Parameter
11626	0	00h to 63h (0 to 99)		Impossible	

20. PROFINET COMMUNICATION

20.9.3.13 Factor Group Objects

(1) Polarity (P24702)

The rotation direction selection can be set. Only 00h, C0h, or E0h can be set. Values other than 00h, C0h, and E0h cannot be set.

Refer to section 8.5 for details.

PNU	Sub	Access	Name	Data Type	Description	Default
24702	0	R/W	Polarity	Unsigned8	Rotation direction	0

PNU	Sub	Range	Units	EEP-ROM	Parameter
24702	0	Refer to the text.		Possible	PA14 (bit 6, 7) PC29 (bit 5)

(2) Position encoder resolution (P24719)

Encoder resolution is returned with Encoder increments (P24719.0).

PNU	Sub	Access	Name	Data Type	Description	Default
24719	0	R/W	Encoder increments	Array [2]	Encoder increments	
	1	R/W	Motor revolutions	Unsigned32	Motor revolutions	1

PNU	Sub	Range	Units	EEP-ROM	Parameter
24719	0	00000000h to FFFFFFFFh	inc	Impossible	
	1	00000001h to 00000001h	rev		

(3) Gear ratio (P24721)

Set the electronic gear. Refer to [Pr. PA06] for the settable values. In the cyclic synchronous mode, always set "1" for Motor revolutions (P24721.0) and Shaft revolutions (P24721.1).

PNU	Sub	Access	Name	Data Type	Description	Default
24721	0	R/W	Motor revolutions	Array [2]	Motor revolutions	1
	1	R/W	Shaft revolutions	Unsigned32	Shaft revolutions	

PNU	Sub	Range	Units	EEP-ROM	Parameter
24721	0	00000001h to 00FFFFFFh (16777215)	rev	Possible	PA06
	PA07				

(4) Feed constant (P24722)

Travel distance per revolution of output shaft is set. Refer to the section of each control mode for details.

PNU	Sub	Access	Name	Data Type	Description	Default
24722	0	R/W	Feed	Array [2]	Travel distance setting	
	1	R/W	Shaft revolutions	Unsigned32	Number of servo motor shaft revolutions	1

PNU	Sub	Range	Units	EEP-ROM	Parameter
24722	0	Refer to the text.	pos units	Impossible	
	1		rev		

20. PROFINET COMMUNICATION

(5) SI unit position (P24744)

The SI position unit is returned.

SI unit position (P24744) is set automatically with the control mode, [Pr. PT01] and [Pr. PT03].

In the indexer method, "00000000h" is returned.

PNU	Sub	Access	Name	Data Type	Description	Default
24744	0	R/W	SI unit position	Unsigned32	SI position unit	0

PNU	Sub	Range	Units	EEP-ROM	Parameter
24744	0	Refer to the following table.	pos units	Impossible	-

[Pr. PT01] setting	[Pr. PT03] setting	Value
_ 0 _ _ (mm)	0 (x 1)	FA010000h (0.001 mm)
	1 (x 10)	FB010000h (0.01 mm)
	2 (x 100)	FC010000h (0.1 mm)
	3 (x 1000)	FD010000h (1 mm)
_ 1 _ _ (inch)	0 (x 1)	FCC00000h (0.0001 inch)
	1 (x 10)	FDC00000h (0.001 inch)
	2 (x 100)	FEC00000h (0.01 inch)
	3 (x 1000)	FFC00000h (0.1 inch)
_ 2 _ _ (degree)		FD410000h (0.001 degree)
_ 3 _ _ (pulse)		00000000h (1 pulse)

(6) SI unit velocity (P24745)

The SI unit velocity is returned.

PNU	Sub	Access	Name	Data Type	Description	Default
24745	0	R/W	SI unit velocity	Unsigned32	SI unit velocity	0

PNU	Sub	Range	Units	EEP-ROM	Parameter
24745	0	FB010300h (0.01 mm/s), FEB44700h (0.01 r/min)	vel units	Impossible	

20. PROFINET COMMUNICATION

20.9.3.14 Optional application FE Objects

(1) Digital inputs (P24829)

The on/off status of the DI signal is returned.

PNU	Sub	Access	Name	Data Type	Description	Default
24829	0	R	Digital inputs	Unsigned32	DI signal status	

PNU	Sub	Range	Units	EEP-ROM	Parameter
24829	0	00000000h to 037E0007h		Impossible	

Bit	Reading connector pin No.	Initial device	Input device changing parameter (Note 2)	Status reading selection parameter (Note 3)	LSP/LSN output reversing parameter (Note 4)	Description
0					PC76	Negative limit switch [Pr. PA14] = 0 0: LSN (Reverse rotation stroke end) off 1: LSN (Reverse rotation stroke end) on [Pr. PA14] = 1 0: LSP (Forward rotation stroke end) off 1: LSP (Forward rotation stroke end) on
1					PC76	Positive limit switch [Pr. PA14] = 0 0: LSP (Forward rotation stroke end) off 1: LSP (Forward rotation stroke end) on [Pr. PA14] = 1 0: LSN (Reverse rotation stroke end) off 1: LSN (Reverse rotation stroke end) on
2						home switch 0: DOG (Proximity dog) off 1: DOG (Proximity dog) on
3 to 16						(reserved) (Note 6)
17	CN3-2	LSP	PD03	PC79	PC76 (Note 5)	DI1 0: Off 1: On
18	CN3-12	LSN	PD04	PC79	PC76 (Note 5)	DI2 0: Off 1: On
19	CN3-19	DOG	PD05	PC79	PC76 (Note 5)	DI3 0: Off 1: On
20	CN3-10	TPR1		PC79		DI4 0: TPR1 (Touch probe 1) off 1: TPR1 (Touch probe 1) on
21	CN3-1	TPR2		PC79		DI5 0: TPR1 (Touch probe 2) off 1: TPR1 (Touch probe 2) on
22	CN3-20	EM2	PA04	PC79		EM2/EM1 0: Off 1: On
23						(reserved) (Note 6)
24	CN8-4					Safe torque off 1 0: STO1 off 1: STO1 on
25	CN8-5					Safe torque off 2 0: STO2 off 1: STO2 on
26 to 31						(reserved) (Note 6)

20. PROFINET COMMUNICATION

2. You can change input devices of the pin with this parameter setting. When [Pr. PD03] to [Pr. PD05] are set to "_ _ 0 0", the ON/OFF state of each pin is returned.
3. With this parameter setting, you can specify whether the ON/OFF states of the input devices are returned or the ON/OFF states of the pins are returned.
4. You can reverse the output with this parameter setting.
5. This parameter is available when [Pr. PC79] is set to "0" (the ON/OFF states of the input devices are returned) while LSP or LSN is assigned to each pin.
6. The values in bit 3 to 16, 23 and 26 to 31 at reading are undefined.

(2) Digital outputs (P24830)

Set the ON/OFF states of the output devices connected to the driver.

PNU	Sub	Access	Name	Data Type	Description	Default
24830	0	R/W	Physical outputs	Unsigned32	ON/OFF setting of the DO signal	0
	1	R/W	Bit mask		Mask settings of the DO signal	0

PNU	Sub	Range	Units	EEP-ROM	Parameter
24830	0	00000000h to 000E0000h		Impossible	
	1				

(a) Physical outputs (P24830: 1)

Bit	Description
0 to 16	(reserved) (Note)
17	DO1 0: DOA (General-purpose output A) off 1: DOA (General-purpose output A) on When using this bit, assign DOA (General-purpose output A) to CN3-9, CN3-13 or CN3-15 pin in [Pr. PD07] to [Pr. PD09].
18	DO2 0: DOB (General-purpose output B) off 1: DOB (General-purpose output B) on When using this bit, assign DOB (General-purpose output B) to CN3-9, CN3-13 or CN3-15 pin in [Pr. PD07] to [Pr. PD09].
19	DO3 0: DOC (General-purpose output C) off 1: DOC (General-purpose output C) on When using this bit, assign DOC (General-purpose output C) to CN3-9, CN3-13 or CN3-15 pin in [Pr. PD07] to [Pr. PD09].
20 to 31	(reserved) (Note)

Note. The values in bit 0 to 16 and 20 to 31 at reading are undefined.

20. PROFINET COMMUNICATION

(b) Bit mask (P24830: 2)

Bit	Description
0 to 16	(reserved) (Note)
17	DO1 0: DOA (General-purpose output A) disabled 1: DOA (General-purpose output A) enabled When this bit is set to "0", bit 17 of the Physical outputs is always "0".
18	DO2 0: DOB (General-purpose output B) disabled 1: DOB (General-purpose output B) enabled When this bit is set to "0", bit 18 of the Physical outputs is always "0".
19	DO3 0: DOC (General-purpose output C) disabled 1: DOC (General-purpose output C) enabled When this bit is set to "0", bit 19 of the Physical outputs is always "0".
20 to 31	(reserved) (Note)

Note. The values in bit 0 to 16 and 20 to 31 at reading are undefined.

20.9.3.15 Touch Probe Function Objects

(1) Details of Touch probe function (P24760)

Set the command for the touch probe function. Refer to section 8.6 (2) for details.

PNU	Sub	Access	Name	Data Type	Description	Default
24760	0	R/W	Touch probe function	Unsigned16	Settings such as enabling/disabling of the touch probe function and trigger conditions	0

PNU	Sub	Range	Units	EEP-ROM	Parameter
24760	0	0000h to FFFFh		Impossible	

(2) Touch probe status (P24761)

The status of the touch probe function is returned. Refer to section 8.6 (3) for details.

PNU	Sub	Access	Name	Data Type	Description	Default
24761	0	R	Touch probe status	Unsigned16	Status information of the touch probe function	

PNU	Sub	Range	Units	EEP-ROM	Parameter
24761	0	0000h to FFFFh		Impossible	

(3) Touch probe pos1 pos value (P24762)

The position latched at the rising edge of touch probe 1 is returned.

PNU	Sub	Access	Name	Data Type	Description	Default
24762	0	R	Touch probe pos1 pos value	Integer32	Shows the rising edge position of Touch probe 1. (command unit)	0

PNU	Sub	Range	Units	EEP-ROM	Parameter
24762	0	80000000h to 7FFFFFFFh	pos units	Impossible	

20. PROFINET COMMUNICATION

(4) Touch probe pos1 neg value (P24763)

The position latched at the falling edge of touch probe 1 is returned.

PNU	Sub	Access	Name	Data Type	Description	Default
24763	0	R	Touch probe pos1 neg value	Integer32	Shows the falling edge position of Touch probe 1. (command unit)	0

PNU	Sub	Range	Units	EEP-ROM	Parameter
24763	0	80000000h to 7FFFFFFFh	pos units	Impossible	

(5) Touch probe pos2 pos value (P24764)

The position latched at the rising edge of touch probe 2 is returned.

PNU	Sub	Access	Name	Data Type	Description	Default
24764	0	R	Touch probe pos2 pos value	Lower software position limit	Shows the rising edge position of Touch probe 2. (command unit)	0

PNU	Sub	Range	Units	EEP-ROM	Parameter
24764	0	80000000h to 7FFFFFFFh	pos units	Impossible	

(6) Touch probe pos2 neg value (P24765) (Drive Configuration Object)

The position latched at the falling edge of touch probe 2 is returned.

PNU	Sub	Access	Name	Data Type	Description	Default
24765	0	Get	Touch probe pos2 neg value	Lower software position limit	Shows the falling edge position of Touch probe 2. (command unit)	0

PNU	Sub	Range	Units	EEP-ROM	Parameter
24765	0	80000000h to 7FFFFFFFh	pos units	Impossible	

APPENDIX

App. 1 Peripheral equipment manufacturer (for reference).....	- 2 -
App. 2 Handling of AC driver batteries for the United Nations Recommendations on the Transport of Dangerous Goods.....	- 2 -
App. 3 Symbol for the new EU Battery Directive	- 4 -
App. 4 Compliance with global standards	- 5 -
App. 4.1 Terms related to safety (IEC 61800-5-2 Stop function).....	- 5 -
App. 4.2 About safety	- 5 -
App. 4.2.1 Professional engineer.....	- 5 -
App. 4.2.2 Applications of the devices	- 5 -
App. 4.2.3 Correct use.....	- 5 -
App. 4.2.4 General cautions for safety protection and protective measures.....	- 8 -
App. 4.2.5 Residual risk.....	- 8 -
App. 4.2.6 Disposal.....	- 8 -
App. 4.2.7 Lithium battery transportation	- 9 -
App. 4.3 Mounting/dismounting	- 9 -
App. 4.4 Electrical Installation and configuration diagram	- 10 -
App. 4.5 Signal.....	- 11 -
App. 4.5.1 Signal	- 11 -
App. 4.5.2 I/O device	- 11 -
App. 4.6 Maintenance and service.....	- 12 -
App. 4.6.1 Inspection items	- 12 -
App. 4.6.2 Parts having service lives	- 13 -
App. 4.7 Transportation and storage.....	- 14 -
App. 4.8 Technical data	- 15 -
App. 4.8.1 LECSND2-T□ driver.....	- 15 -
App. 4.8.2 Driver dimensions.....	- 15 -
App. 4.8.3 Mounting hole.....	- 15 -
App. 4.9 Check list for user documentation	- 16 -
App. 5 MR-J3-D05 Safety logic unit of Mitsubishi Electric Corporation	- 16 -
App. 5.1 Terms related to safety.....	- 16 -
App. 5.1.1 Stop function for IEC/EN 61800-5-2	- 16 -
App. 5.1.2 Emergency operation for IEC/EN 60204-1	- 16 -
App. 5.2 Cautions	- 17 -
App. 5.3 Residual risk	- 17 -
App. 7 Analog monitor	- 18 -
App. 8 Encoder output pulse setting method	- 21 -
App. 9 Recommended parameter values for each actuator	- 22 -

APPENDIX

App. 1 Peripheral equipment manufacturer (for reference)

Names given in the table are as of December 2017.

Manufacturer	Reference
NEC TOKIN	NEC TOKIN Corporation
Kitagawa Industries	Kitagawa Industries Co., Ltd.
JST	J.S.T. Mfg. Co., Ltd.
Junkosha	Purchase from Toa Electric Industry Co. Ltd., Nagoya Branch
3M	Sumitomo 3M Ltd.
SEIWA ELECTRIC	Seiwa Electric Mfg. Co. Ltd.
Soshin Electric	Soshin Electric Co., Ltd.
TE Connectivity	TE Connectivity Ltd. Company
TDK	TDK Corporation
Molex	Molex
Toho Technology	Toho Technology Corp. Kyoto factory

App. 2 Handling of AC driver batteries for the United Nations Recommendations on the Transport of Dangerous Goods

United Nations Recommendations on the Transport of Dangerous Goods Rev. 15 (hereinafter Recommendations of the United Nations) has been issued. To reflect this, transport regulations for lithium metal batteries are partially revised in the Technical Instruction (ICAO-TI) by the International Civil Aviation Organization (ICAO) and the International Maritime Dangerous Goods Code (IMDG Code) by the International Maritime Organization (IMO).

To comply the instruction and code, we have modified the indication on the package for general-purpose AC servo batteries.

The above change will not affect the function and performance of the product.

(1) Target model

Option model	Type	Lithium content	Mass of battery	Remark
MR-BAT6V1SET-A	Assembled battery (Two)	1.20 g	34 g	Assembled batteries with more than 0.3 grams of lithium content must be handled as dangerous goods (Class 9) depending on packaging requirements.

(2) Purpose

Safer transportation of lithium metal batteries.

(3) Change in regulations

The following points are changed for lithium metal batteries in transportation by sea or air based on the revision of Recommendations of the United Nations Rev. 15 and ICAO-TI 2009-2010 edition, and IATA Dangerous Goods Regulations 54th Edition (effective January 1, 2013). For lithium metal batteries, cells are classified as UN3090, and batteries contained in or packed with equipment are classified as UN3091.

APPENDIX

(a) Transportation of lithium metal batteries alone

Packaging requirement	Classification	Main requirement
Less than eight cells per package with less than one gram of lithium content	UN3090 PI968 Section II	The package must pass a 1.2 m drop test, and the handling label with battery illustration (size: 120 x 110 mm) must be attached on the package.
Less than two assembled batteries per package with less than two grams of lithium content		
More than eight cells per package with less than one gram of lithium content	UN3090 PI968 Section IB	The package must pass a 1.2 m drop test, and the handling label with battery illustration (size: 120 x 110 mm) must be attached on the package. The Class 9 hazard label must be attached or others to comply with dangerous goods (Class 9).
More than two assembled batteries per package with less than two grams of lithium content		
Cells with more than one gram of lithium content	UN3090 PI968 Section IA	The package must be compliant with Class 9 Packages, and the Class 9 hazard label must be attached or others to comply with dangerous goods (Class 9).
Assembled batteries with more than two grams of lithium content		

(b) Transportation of lithium metal batteries packed with or contained in equipment

- 1) For batteries packed with equipment, follow the necessary requirements of UN3091 PI969. Batteries are classified into either Section II/Section I depending on the lithium content/packaging requirements.
- 2) For batteries contained in equipment, follow the necessary requirements of UN3091 PI970. Batteries are classified into either Section II/Section I depending on the lithium content/packaging requirements.
The special handling may be unnecessary depending on the number of batteries and gross mass per package.



Fig. app. 1 Example of label with battery illustration

(Available until December 31, 2018)

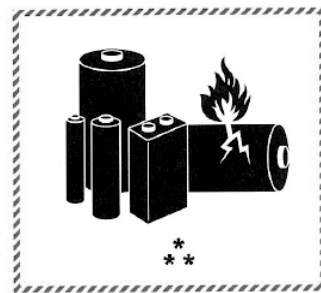

* Place for UN number (s)
** Place for telephone number for additional information

Fig. app. 2 Example of label with battery illustration

(Available from January 1, 2017)

The handling label shown in Fig. app. 1 has been changed to the one shown in Fig. app. 2 in accordance with the IATA Dangerous Goods Regulations 58th Edition (effective January 1, 2017). However, the label shown in Fig. app. 1 may be used until December 31, 2018 (for two years as an interim measure).

(4) Details of the package change

The following caution is added to the packages of the target batteries.
"Containing lithium metal battery. Regulations apply for transportation."

APPENDIX

(5) Transportation precaution for customers

For sea or air transportation, attaching the handling label (Fig. app. 1) must be attached to the package of battery. In addition, attaching it to the outer package containing several packages of batteries is also required. When the content of a package must be handled as dangerous goods (Class 9), the Shipper's Declaration for Dangerous Goods is required, and the package must be compliant with Class 9 Packages. Documentations like the handling label in the specified design and the Shipper's Declaration for Dangerous Goods are required for transportation. Please attach the documentations to the packages and the outer package.

The IATA Dangerous Goods Regulations are revised, and the requirements are changed annually. When customers transport lithium batteries by themselves, the responsibility for the cargo lies with the customers. Thus, be sure to check the latest version of the IATA Dangerous Goods Regulations.

App. 3 Symbol for the new EU Battery Directive

Symbol for the new EU Battery Directive (2006/66/EC) that is plastered to general-purpose AC servo battery is explained here.



Note. This symbol mark is for EU countries only.

This symbol mark is according to the directive 2006/66/EC Article 20 Information for end-users and Annex II.

Product is designed and manufactured with high quality materials and components which can be recycled and/or reused.

This symbol means that batteries and accumulators, at their end-of-life, should be disposed of separately from your household waste.

If a chemical symbol is printed beneath the symbol shown above, this chemical symbol means that the battery or accumulator contains a heavy metal at a certain concentration.

This will be indicated as follows.

Hg: mercury (0.0005%), Cd: cadmium (0.002%), Pb: lead (0.004%)

In the European Union there are separate collection systems for used batteries and accumulators.

Please, dispose of batteries and accumulators correctly at your local community waste collection/recycling center.

Please, help us to conserve the environment we live in!

APPENDIX

App. 4 Compliance with global standards

App. 4.1 Terms related to safety (IEC 61800-5-2 Stop function)

STO function (Refer to IEC 61800-5-2:2007 4.2.2.2 STO.)

The LECSND2-T□ drivers have the STO function. The STO function shuts down energy to servo motors, thus removing torque. This function electronically cuts off power supply in the driver.

App. 4.2 About safety

This chapter explains safety of users and machine operators. Please read the section carefully before mounting the equipment.

App. 4.2.1 Professional engineer

Only professional engineers should mount LECSND2-T□ drivers.

Here, professional engineers should meet the all conditions below.

- (1) Persons who took a proper training of related work of electrical equipment or persons who can avoid risk based on past experience.
- (2) Persons who have read and familiarized himself/herself with this installation guide and operating manuals for the protective devices (e.g. light curtain) connected to the safety control system.

App. 4.2.2 Applications of the devices

- IEC/EN 61800-5-1, IEC/EN 61800-3, IEC/EN 60204-1
- ISO/EN ISO 13849-1 Category 3 PL e, IEC/EN 62061 SIL CL 3, IEC/EN 61800-5-2 (STO)

LECSND2-T□ drivers can be used with the MR-D30 functional safety unit of Mitsubishi Electric Corporation, MR-J3-D05 safety logic unit of Mitsubishi Electric Corporation, or safety PLCs.

App. 4.2.3 Correct use

Use the LECSND2-T□ drivers within specifications. Refer to section 1.3 for specifications such as voltage, temperature, etc. SMC Co. accepts no claims for liability if the equipment is used in any other way or if modifications are made to the device, even in the context of mounting and installation.



WARNING

- If you need to get close to the moving parts of the machine for inspection or others, ensure safety by confirming the power off, etc. Otherwise, it may cause an accident.
- It takes 15 minutes maximum for capacitor discharging. Do not touch the unit and terminals immediately after power off.

(1) Peripheral device and power wiring

The followings are selected based on IEC/EN 61800-5-1, UL 508C, and CSA C22.2 No. 14

(a) Power Wiring (local wiring and crimping tool)

Use only copper wires or copper bus bars for wiring. The following table shows the stranded wire sizes [AWG] and the crimp terminal symbols rated at 75 °C/60 °C.

Driver	75 °C / 60 °C stranded wire [AWG]			
	L1/L2/L3 ⊕	L11/L21	P+/C	U/V/W/⊕ (Note 1)
LECSND□-T5/ LECSND□-T7/ LECSND□-T8/ LECSND2-T9	14/14	14/14	14/14	14/14

Note 1. Select wire sizes depending on the rated output of the servo motors. The values in the table are sizes based on rated output of the drivers.

APPENDIX

(b) Selection example of MCCB and fuse

Use T class fuses or molded-case circuit breaker (UL489 Listed MCCB) as the following table. The T class fuses and molded-case circuit breakers in the table are selected examples based on rated I/O of the drivers. When you select a smaller capacity servo motor to connect it to the driver, you can also use smaller capacity T class fuses or molded-case circuit breaker than ones in the table.

Driver (Note 1)	Molded-case circuit breaker (240 V AC) (Note 2)	Fuse (300 V)
LECSND2-T5/ LECSND2-T7/ LECSND2-T8/ LECSND2-T9 (S)	NF50-SVFU-5A (50 A frame 5 A)	10 A

Note 1. “(S)” means 1-phase 200 V AC power input and “(T)” means 3-phase 200 V AC power input in the table.

(c) Power supply

This driver can be supplied from star-connected supply with grounded neutral point of overvoltage category III (overvoltage category II for 1-phase drivers) set forth in IEC/EN 60664-1. For the interface power supply, use an external 24 V DC power supply with reinforced insulation on I/O terminals.

(d) Grounding

To prevent an electric shock, always connect the protective earth (PE) terminal (marked \oplus) of the driver to the protective earth (PE) of the cabinet. Do not connect two grounding cables to the same protective earth (PE) terminal. Always connect cables to the terminals one-to-one.

This product can cause a DC current in the protective earthing conductor. To protect direct/indirect contact using an earth-leakage current breaker (RCD), only an RCD of type B can be used for the power supply side of the product.



APPENDIX

(2) EU compliance

The EC directives were issued to standardize the regulations of the EU countries and ensure smooth distribution of safety-guaranteed products. The CE marking proves the compliance of the manufacturer with the EC directives, and this marking also applies to machines and equipment incorporating servos.

(a) EMC requirement

LECSND2-T□ drivers comply with category C3 in accordance with EN 61800-3. As for I/O wires (max. length 10 m. However, 3 m for STO cable for CN8.) and encoder cables (max. length 10 m), use shielded wires and ground the shields. Install an EMC filter and surge protector on the primary side for input and output of LECSND□-T□ drivers. The following shows recommended products.

EMC filter: Soshin Electric HF3000A-UN series, TF3000C-TX series, COSEL FTB series

Surge protector: Okaya Electric Industries RSPD series

Line noise filter: Mitsubishi Electric FR-BLF

LECSND2-T□ drivers are not intended to be used on a low-voltage public network which supplies domestic premises; radio frequency interference is expected if used on such a network. The installer shall provide a guide for Installation and use, including recommended mitigation devices. To avoid the risk of crosstalk to signal cables, the installation instructions shall either recommend that the power interface cable be segregated from signal cables.

Use the DC power supply installed with the drivers in the same cabinet. Do not connect the other electric devices to the DC power supply.

(3) USA/Canada compliance

This driver is designed in compliance with UL 508C and CSA C22.2 No. 14.

(a) Installation

The minimum cabinet size is 150% of each LECSND2-T□ driver's volume. Also, design the cabinet so that the ambient temperature in the cabinet is 55 °C or less. The driver must be installed in the metal cabinet. Additionally, mount the driver on a cabinet that the protective earth based on the standard of IEC/EN 60204-1 is correctly connected. For environment, the units should be used in open type (UL 50) and overvoltage category shown in table in app. 4.8.1. The driver needs to be installed at or below pollution degree 2. For connection, use copper wires.

(b) Short-circuit current rating (SCCR)

Suitable For Use On A Circuit Capable Of Delivering Not More Than 100 kA rms Symmetrical Amperes, 500 Volts Maximum.

APPENDIX

(c) Overload protection characteristics

The LECSND2-T□ drivers have solid-state servo motor overload protection. (It is set on the basis (full load current) of 120% rated current of the driver.)

(d) Over-temperature protection for motor

Motor Over temperature sensing is not provided by the drive.

Integral thermal protection(s) is necessary for motor and refer to app. 4.4 for the proper connection.

(e) Branch circuit protection

For installation in United States, branch circuit protection must be provided, in accordance with the National Electrical Code and any applicable local codes.

For installation in Canada, branch circuit protection must be provided, in accordance with the Canada Electrical Code and any applicable provincial codes.

App. 4.2.4 General cautions for safety protection and protective measures

Observe the following items to ensure proper use of the LECSND2-T□ drivers.

- (1) For safety components and installing systems, only qualified personnel and professional engineers should perform.
- (2) When mounting, installing, and using the LECSND2-T□ driver, always observe standards and directives applicable in the country.
- (3) The item about noises of the test notices in the manuals should be observed.

App. 4.2.5 Residual risk

- (1) Be sure that all safety related switches, relays, sensors, etc., meet the required safety standards.
- (2) Perform all risk assessments and safety level certification to the machine or the system as a whole.
- (3) If the upper and lower power module in the driver are shorted and damaged simultaneously, the servo motor may make a half revolution at a maximum.
- (4) Only qualified personnel are authorized to install, start-up, repair or service the machines in which these components are installed. Only trained engineers should install and operate the equipment. (ISO 13849-1 Table F.1 No. 5)
- (5) Separate the wiring for safety observation function from other signal wirings. (ISO 13849-1 Table F.1 No. 1)
- (6) Protect the cables with appropriate ways (routing them in a cabinet, using a cable guard, etc.).
- (7) Keep the required clearance/creepage distance depending on voltage you use.

App. 4.2.6 Disposal

Disposal of unusable or irreparable devices should always occur in accordance with the applicable country-specific waste disposal regulations. (Example: European Waste 16 02 14)

APPENDIX

App. 4.2.7 Lithium battery transportation

To transport lithium batteries, take actions to comply with the instructions and regulations such as the United Nations (UN), the International Civil Aviation Organization (ICAO), and the International Maritime Organization (IMO).

The batteries are assembled batteries from two batteries (lithium metal battery CR17335A) which are not subject to the dangerous goods (Class 9) of the UN Recommendations.

App. 4.3 Mounting/dismounting

Installation direction and clearances

CAUTION

- The devices must be installed in the specified direction. Not doing so may cause a malfunction.
- Mount the driver on a cabinet which meets IP54 in the correct vertical direction to maintain pollution degree 2.

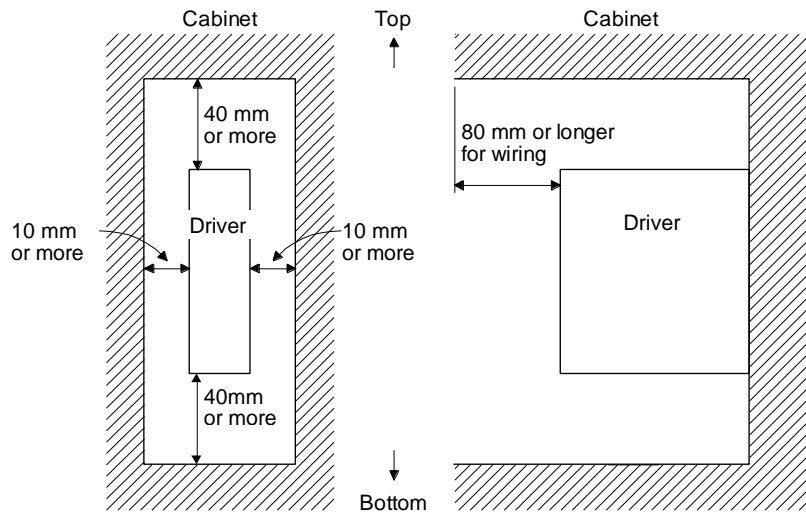

APPENDIX

App. 4.4 Electrical Installation and configuration diagram

⚠ WARNING ● Turn off the molded-case circuit breaker (MCCB) to avoid electrical shocks or damages to the product before starting the installation or wiring.

⚠ CAUTION ● The installation complies with IEC/EN 60204-1. The voltage supply to machines must be 20 ms or more of tolerance against instantaneous power failure as specified in IEC/EN 60204-1.
 ● Connecting a servo motor for different axis to U, V, W, or CN2_ of the driver may cause a malfunction.
 ● Securely connect the cables in the specified method and tighten them with the specified torque. Otherwise, the servo motor may operate unexpectedly.

The following shows representative configuration examples to conform to the IEC/EN/UL/CSA standards.

(1) 3-phase input for LECSND2-T□ 1-axis driver

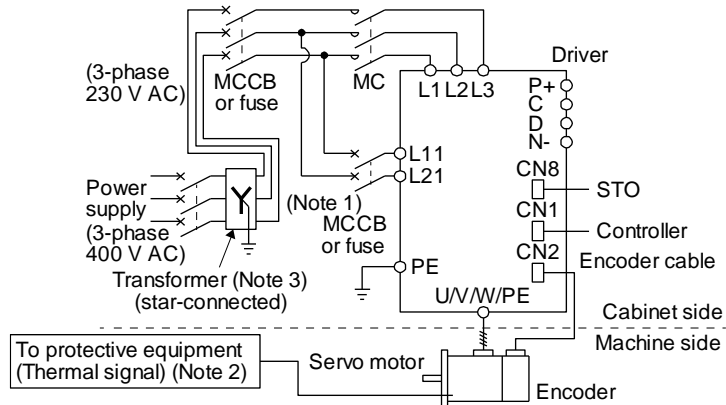

- Note 1. When the wire sizes of L1 and L11 are the same, MCCB or fuse is not required.
 Note 2. Please use a thermal sensor, etc. for thermal protection of the servo motor.

(2) 1-phase input for LECSND2-T□ 1-axis driver

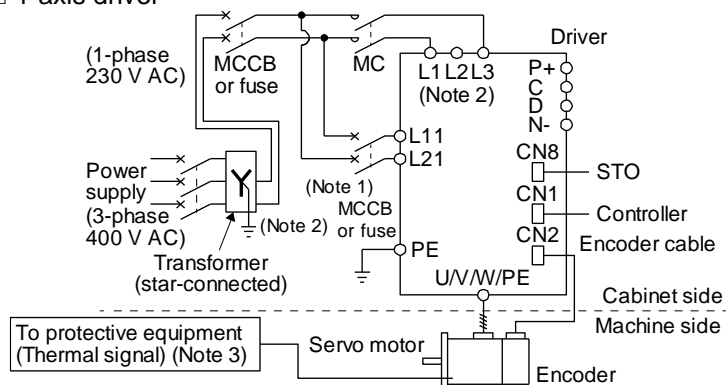

- Note 1. When the wire sizes of L1 and L11 are the same, MCCB or fuse is not required.
 Note 2. When using a 100 V class driver, step down the power supply voltage to 100 V and connect the main circuit power supply lines to L1 and L2. For 1-phase 200 V AC drivers, connect the lines to L1 and L3.
 Note 3. Please use a thermal sensor, etc. for thermal protection of the servo motor.

APPENDIX

The connectors described by rectangles are safely separated from the main circuits described by circles. The connected motors will be limited as follows.

- (1) Servo motor series LE-□-□
- (2) Using a servo motor complied with IEC 60034-1 and Mitsubishi Electric encoder (OBA, OSA)

App. 4.5 Signal
App. 4.5.1 Signal

The following shows LECSND2-T5 signals as a typical example. For other drivers, refer to each driver instruction manual.

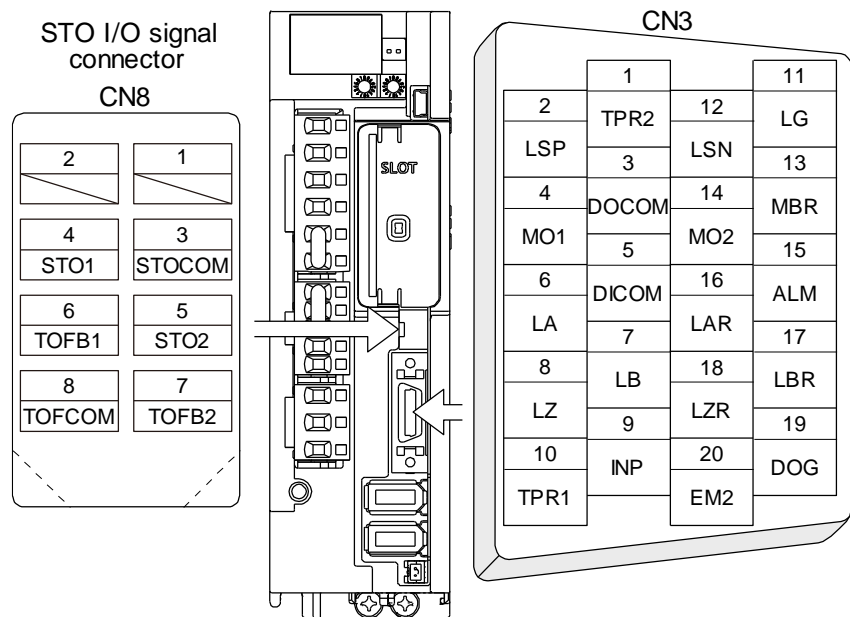

App. 4.5.2 I/O device

Input device

Symbol	Device	Connector	Pin No.
EM2	Forced stop 2	CN3	20
STOCOM	Common terminal for input signals STO1/STO2	CN8	3
STO1	STO1 state input		4
STO2	STO2 state input		5

Output device

Symbol	Device	Connector	Pin No.
TOFCOM	Common terminal for monitor output signal in STO state	CN8	8
TOFB1	Monitor output signal in STO1 state		6
TOFB2	Monitor output signal in STO2 state		7

Power supply

Symbol	Device	Connector	Pin No.
DICOM	Digital I/F power supply input	CN3	5, 10
DOCOM	Digital I/F common		3
SD	Shield		Plate

APPENDIX

App. 4.6 Maintenance and service

 **WARNING** ● To avoid an electric shock, only qualified personnel should attempt inspections.

 **CAUTION** ● Do not perform insulation resistance test on the driver. Otherwise, it may cause a malfunction.
● Do not disassemble and/or repair the equipment on customer side.

App. 4.6.1 Inspection items

It is recommended that the following points periodically be checked.

- (1) Check for loose terminal block screws. Retighten any loose screws.

Driver	Tightening torque [N•m]
	PE
LECSND□-T5 / LECSND□-T7 / LECSND□-T8 / LECSND2-T9	1.2

- (2) Check servo motor bearings, lock section, etc. for unusual noise.
- (3) Check the cables and the like for scratches or cracks. Perform periodic inspection according to operating conditions.
- (4) Check that the connectors are securely connected to the servo motor.
- (5) Check that the wires are not coming out from the connector.
- (6) Check for dust accumulation on the driver.
- (7) Check for unusual noise generated from the driver.
- (8) Check the servo motor shaft and coupling for connection.
- (9) Make sure that the emergency stop circuit operates properly such that an operation can be stopped immediately and a power is shut off by the emergency stop switch.

APPENDIX

App. 4.6.2 Parts having service lives

Service life of the following parts is listed below. However, the service life varies depending on operation and environment.

Part name	Life guideline
Smoothing capacitor	10 years (Note 3)
Relay	Number of power-on, forced stop and PC or PLC...etc forced stop times: 100 000 times Number of on and off for STO: 1,000,000 times
Cooling fan	10,000 hours to 30,000 hours (2 years to 3 years) (Note 4)
Battery backup time (Note 1)	Approximately 20,000 hours (equipment power supply: off, ambient temperature: 20 °C)
Battery life (Note 2)	5 years from date of manufacture

- Note
1. The time is for using MR-BAT6V1SET-A. For details and other battery backup time, refer to chapter 12.2.
 2. Quality of the batteries degrades by the storage condition. The battery life is 5 years from the production date regardless of the connection status.
 3. The characteristic of smoothing capacitor is deteriorated due to ripple currents, etc. The life of the capacitor greatly depends on ambient temperature and operating conditions. The capacitor will be the end of its life in 10 years of continuous operation in air-conditioned environment (ambient temperature of 40 °C or less).

APPENDIX

App. 4.7 Transportation and storage

 CAUTION	<ul style="list-style-type: none"> ● Transport the products correctly according to their mass. ● Stacking in excess of the limited number of product packages is not allowed. ● Do not carry the driver by the front cover during transportation. The product may fall. ● For detailed information on transportation and handling of the battery, refer to app. 2 and app. 3. ● Install the product in a load-bearing place of driver and servo motor in accordance with the manual. ● Do not get on or put heavy load on the equipment. ● Do not hold the cables, or connectors when carrying the driver. Otherwise, it may drop.
--	---

When you keep or use it, please fulfill the following environment.

Item		Environment
Ambient temperature	Operation [°C]	0 to 55 Class 3K3 (IEC/EN 60721-3-3)
	Transportation (Note) [°C]	-20 to 65 Class 2K4 (IEC/EN 60721-3-2)
	Storage (Note) [°C]	-20 to 65 Class 1K4 (IEC/EN 60721-3-1)
Ambient humidity	Operation, transportation, storage	5% to 90 %RH
Vibration load	Test condition	10 Hz to 57 Hz with constant amplitude of 0.075 mm 57 Hz to 150 Hz with constant acceleration of 9.8 m/s ² to IEC/EN 61800-5-1 (Test Fc of IEC 60068-2-6)
	Operation	5.9 m/s ²
	Transportation (Note)	Class 2M3 (IEC/EN 60721-3-2)
	Storage	Class 1M2 (IEC/EN 60721-3-2)
Pollution degree		2
IP rating		IP20 (IEC/EN 60529), Terminal block IP00 Open type (UL 50)
Altitude	Operation, storage	Max. 2000 m above sea level
	Transportation	Max. 10000 m above sea level

Note. In regular transport packaging

APPENDIX

App. 4.8 Technical data

App. 4.8.1 LECSND2-T□ driver

Item		LECSND2-T5 / LECSND2-T7 / LECSND2-T8 / LECSND2-T9
Power supply	Main circuit (line voltage)	3-phase or 1-phase 200 V AC to 240 V AC, 50 Hz/60 Hz
	Control circuit (line voltage)	1-phase 200 V AC to 240 V AC, 50/60 Hz (Note 2)
	Interface (SELV)	24 V DC (required current capacity: LECSND2-T□, 300 mA)
Control method		Sine-wave PWM control, current control method
Safety observation function (STO) IEC/EN 61800-5-2 (Note 3)		EN ISO 13849-1 Category 3 PL e, IEC 61508 SIL 3, EN 62061 SIL CL 3, and EN 61800-5-2
Mean time to dangerous failure		MTTFd ≥ 100 [years]
Effectiveness of fault monitoring of a system or subsystem		DC = Medium, 97.6 [%]
Average probability of dangerous failures per hour		PFH = 6.4×10^{-9} [1/h]
Mission time		$T_M = 20$ [years]
Response performance		8 ms or less (STO input off → energy shut off)
Pollution degree		2 (IEC/EN 60664-1)
Overvoltage category		1-phase 100 V AC/200 V AC: II (IEC/EN 60664-1), 3-phase 200 V AC/400 V AC: III (IEC/EN 60664-1)
Protective class		I (IEC/EN 61800-5-1)
Short-circuit current rating (SCCR)		100 kA

App. 4.8.2 Driver dimensions

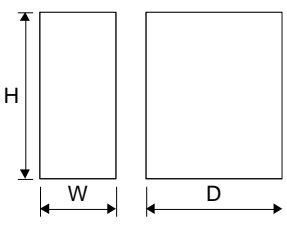

Driver	Variable dimension [mm]			Mass [kg]
	W	H	D	
LECSND□-T5 / LECSND□-T7/ LECSND□-T8	50	168	161	1.0
LECSND2-T9	60	168	191	1.4

App. 4.8.3 Mounting hole

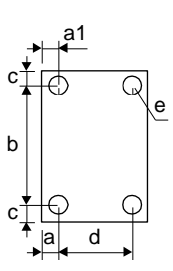

Driver	Variable dimensions [mm]					Screw size
	a	a1	b	c	d	
LECSND□-T5 / LECSND□-T7/ LECSND□-T8	6	6	156 ± 0.5	6		M5
LECSND2-T9	12	12	156 ± 0.5	6	42 ± 0.3	M5

APPENDIX

App. 4.9 Check list for user documentation

LECS installation checklist for manufacturer/installer

The following items must be satisfied by the initial test operation at least. The manufacturer/installer must be responsible for checking the standards in the items.

Maintain and keep this checklist with related documents of machines to use this for periodic inspection.

- | | |
|---|-----------------|
| 1. Is it based on directive/standard applied to the machine? | Yes [], No [] |
| 2. Is directive/standard contained in Declaration of Conformity (DoC)? | Yes [], No [] |
| 3. Does the protection instrument conform to the category required? | Yes [], No [] |
| 4. Are electric shock protective measures (protective class) effective? | Yes [], No [] |
| 5. Is the STO function checked (test of all the shut-off wiring)? | Yes [], No [] |

Checking the items will not be instead of the first test operation or periodic inspection by professional engineers.

App. 5 MR-J3-D05 Safety logic unit of Mitsubishi Electric Corporation

App. 5.1 Terms related to safety

App. 5.1.1 Stop function for IEC/EN 61800-5-2

(1) STO function (Refer to IEC/EN 61800-5-2: 2007 4.2.2.2 STO.)

This function is integrated into the LECSND□-T□ series drivers.

The STO function shuts down energy to servo motors, thus removing torque. This function electronically cuts off power supply in drivers for LECSND□-T□ series drivers.

The purpose of this safety function is as follows.

- 1) Uncontrolled stop according to stop category 0 of IEC/EN 60204-1
 - 2) Preventing unexpected start-up
- (2) SS1 function (Refer to IEC/EN 61800-5-2: 2007 4.2.2.3C Safe stop 1 temporal delay.)
- SS1 is a function which initiates the STO function when the previously set delay time has passed after the servo motor starts decelerating. The delay time can be set with MR-J3-D05 of Mitsubishi Electric Corporation.
- The purpose of this safety function is as follows. This function is available by using an LECSND□-T□ series driver with MR-J3-D05 of Mitsubishi Electric Corporation.

- Controlled stop according to stop category 1 of IEC/EN 60204-1

App. 5.1.2 Emergency operation for IEC/EN 60204-1

(1) Emergency stop (Refer to IEC/EN 60204-1: 2005 9.2.5.4.2 Emergency Stop.)

Emergency stop must override all other functions and actuation in all operation modes. Power to the machine driving part which may cause a hazardous state must be either removed immediately (stop category 0) or must be controlled to stop such hazardous state as soon as possible (stop category 1). Restart must not be allowed even after the cause of the emergency state has been removed.

- (2) Emergency switching off (Refer to IEC/EN 60204-1: 2005 9.2.5.4.3 Emergency Switching OFF.)
- Removal of input power to driving device to remove electrical risk and to meet above mentioned safety standards.

APPENDIX

App. 5.2 Cautions

The following basic safety notes must be read carefully and fully in order to prevent injury to persons or damage to property.

Only qualified personnel are authorized to install, start-up, repair or service the machines in which these components are installed.

They must be familiar with all applicable local safety regulations and laws in which machines with these components are installed, particularly the standards and guidelines mentioned in this Instruction Manual and the requirements mentioned in ISO/EN ISO 13849-1, IEC 61508, IEC/EN 61800-5-2, and IEC/EN 60204-1.

The staff responsible for this work must be given express permission from the company to perform start-up, programming, configuration, and maintenance of the machine in accordance with the safety standards.



WARNING

● Improper installation of the safety related components or systems may cause improper operation in which safety is not assured, and may result in severe injuries or even death.

Protective Measures

- As described in IEC/EN 61800-5-2, the Safe Torque Off (STO) function only prevents the driver from supplying energy to the servo motor. Therefore, if an external force acts upon the drive axis, additional safety measures, such as locks or counter-weights must be used.

App. 5.3 Residual risk

Machine manufacturers are responsible for all risk evaluations and all associated residual risks. Below are residual risks associated with the STO/EMG function. SMC Co. is not liable for any damages or injuries caused by the residual risks.

- (1) The SS1 function only guarantees the delay time before STO/EMG is engaged. Proper setting of this delay time is the full responsibility of the company and/or individuals responsible for installation and commissioning of the safety related system. The system, as a whole, must pass safety standards certification.
- (2) When the SS1 delay time is shorter than the required servo motor deceleration time, if the forced stop function is malfunctioning, or if STO/EMG is engaged while the servo motor is still rotating; the servo motor will stop with the dynamic brake or freewheeling.
- (3) For proper installation, wiring, and adjustment, thoroughly read the manual of each individual safety related component.
- (4) Be sure that all safety related switches, relays, sensors, etc., meet the required safety standards.
- (5) Safety is not assured until safety-related components of the system are completely installed or adjusted.
- (6) When replacing a driver etc. or MR-J3-D05 of Mitsubishi Electric Corporation, confirm that the new equipment is exactly the same as those being replaced. Once installed, be sure to verify the performance of the functions before commissioning the system.

APPENDIX

- (7) Perform all risk assessments and safety level certification to the machine or the system as a whole. It is recommended that a Certification Body final safety certification of the system be used.
- (8) To prevent accumulation of multiple malfunctions, perform a malfunction check at regular intervals as deemed necessary by the applicable safety standard. Regardless of the system safety level, malfunction checks should be performed at least once per year.
- (9) If the upper and lower power module in the driver are shorted and damaged simultaneously, the servo motor may make a half revolution at a maximum.

App. 7 Analog monitor

POINT	
●A voltage of analog monitor output may be irregular at power-on.	

The servo status can be output to two channels in terms of voltage.

(1) Setting

Change the following digits of [Pr. PC09] and [Pr. PC10].

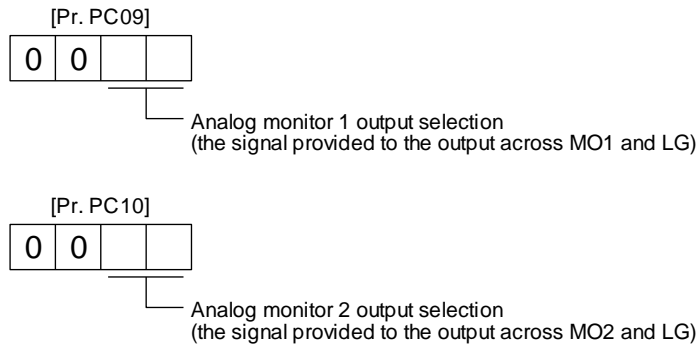

[Pr. PC11] and [Pr. PC12] can be used to set the offset voltages to the analog output voltages. Setting value is -999 mV to 999 mV.

Parameter	Description	Setting range [mV]
PC11	This is used to set the offset voltage of MO1 (Analog monitor 1).	-999 to 999
PC12	This is used to set the offset voltage of MO2 (Analog monitor 2).	

APPENDIX

(2) Setting

The driver is factory-set to output the servo motor speed to MO1 (Analog monitor 1) and the torque to MO2 (Analog monitor 2). The setting can be changed as listed below by setting the [Pr. PC09] and [Pr. PC10] value.

Setting value	Output item	Description	Setting value	Output item	Description
00	Servo motor speed		01	Torque/Thrust (Note 7)	
02	Servo motor speed		03	Torque/Thrust (Note 7)	
04	Current command (Note 7)		05	Speed command (Note 3)	
06	Servo motor-side droop pulses (Note 1, 3, 5, 6) (± 10 V/100 pulses)		07	Servo motor-side droop pulses (Note 1, 3, 5, 6) (± 10 V/1000 pulses)	
08	Servo motor-side droop pulses (Note 1, 3, 5, 6) (± 10 V/10000 pulses)		09	Servo motor-side droop pulses (Note 1, 3, 5, 6) (± 10 V/100000 pulses)	

APPENDIX

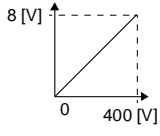
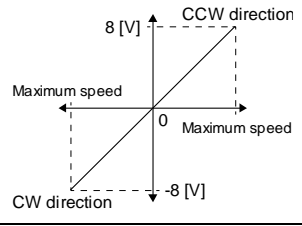
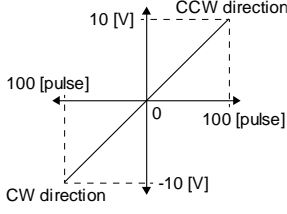
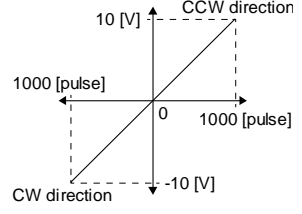
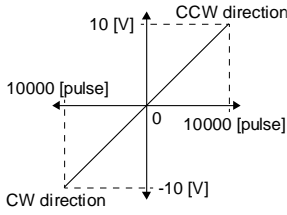
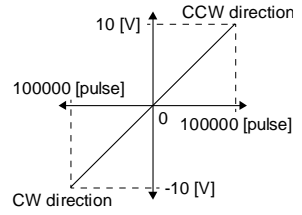
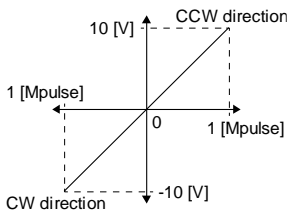
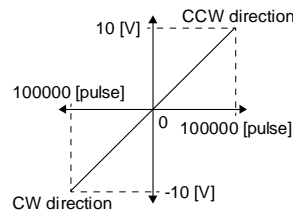
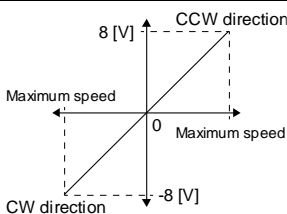
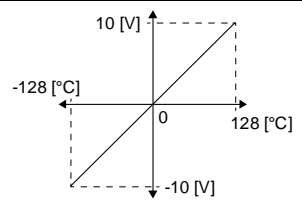
Setting value	Output item	Description	Setting value	Output item	Description
0D	Bus voltage (Note 4)		0E	Speed command 2 (Note 3)	
10	Load-side droop pulses (Note 3, 5, 6) (± 10 V/100 pulses)		11	Load-side droop pulses (Note 3, 5, 6) (± 10 V/1000 pulses)	
12	Load-side droop pulses (Note 3, 5, 6) (± 10 V/10000 pulses)		13	Load-side droop pulses (Note 3, 5, 6) (± 10 V/100000 pulses)	
14	Load-side droop pulses (Note 3, 5, 6) (± 10 V/1 Mpulses)		15	Motor-side/load-side position deviation (Note 3, 5, 6) (± 10 V/100000 pulses)	
16	Servo motor-side/load-side speed deviation		17	Internal temperature of encoder (± 10 V/ ± 128 °C)	

Note 1. Encoder pulse unit.

2. Available in position mode

3. This cannot be used in the torque mode.

5. This cannot be used in the velocity mode.

7. For details on the value of the maximum current command (maximum torque) for ± 8 V, refer to app. 7.3.

APPENDIX

(3) Values of the maximum current command when the analog monitor is at the maximum/minimum voltage

Values of the maximum current command when the analog monitor is at the maximum/minimum voltage are listed.

The current command (torque) outputs the maximum current command (maximum torque) at ± 8 V. The maximum current command may not match the rated current/maximum current ratio since it is created from the torque current in the driver.

Servo motor LE-□-□	Driver/drive unit	Maximum current command (maximum torque) [%]
T6	LECSND□-T5	373
T7	LECSND□-T7	387
T8	LECSND□-T8	383
T9	LECSND2-T9	367

App. 8 Encoder output pulse setting method

For details of "Encoder output pulse setting selection" in [Pr. PC03], refer to the following table.

Setting value	Servo motor
__0__ (Output pulse setting)	Set the output pulses per revolution with [Pr. PA15 Encoder output pulses]. Output pulse = a value set in [Pr. PA15] [pulse/rev] Selecting "Load side encoder (_1_)" of "Encoder selection for encoder output pulse" in [Pr. PC19] triggers [AL. 37 Parameter error].
__1__ (Dividing ratio setting)	Set the dividing ratio to the resolution per servo motor revolution with [Pr. PA15 Encoder output pulses]. Output pulse = $\frac{\text{Resolution per revolution}}{\text{[Pr. PA15] setting}}$ [pulse/rev]
__3__ (A-phase/B-phase pulse electronic gear setting)	Set the A-phase/B-phase pulse electronic gear with [Pr. PA15 Encoder output pulses] and [Pr. PA16 Encoder output pulses 2]. Output pulse = the servo motor resolution per revolution $\times \frac{\text{[Pr. PA15] setting}}{\text{[Pr. PA16] setting}}$ [pulse/rev]
__4__ (A/B-phase pulse through output setting)	[AL. 37 Parameter error] occurs.

APPENDIX

App .9 Recommended parameter values for each actuator

Please change the parameter values according to the customer application. See section 5 of the "LECSND2-T□ Operation Manual" for details.

Recommended Parameter Values [LEF]

Series	Lead symbol		LEFS25			LEFS32			LEFS40		
			H	A	B	H	A	B	H	A	B
			Lead	20	12	6	24	16	8	30	20
Parameter *1,*2	Para No	Initial value	Recommended Value								
Electronic gear numerator *3.	PA06	1	4194304								
Electronic gear denominator *3.	PA07	1	20000	12000	6000	24000	16000	8000	30000	20000	10000
Command mode selection *3	PT01	0300	0000								
Feel length multiplication (STM) (Multiplier)	PT03	0000	0000 ((<1000 stroke)/0001 (>1000 stroke))								
Home position return method *5	PT45	37	-4								
Home position return Speed (rpm)	PT05	100	90	150	300	75	113	225	60	90	180
Stopper type home position return stopper time (msec)	PT10	100	200								
Stopper type home position return torque limit value (%)	PT11	15	84								
Home position return acceleration time constant (msec)	PT56	0	1000	600	300	1200	800	400	1500	1000	500
Regenerative option	PA02	0000	0000 (Non)/0002 (LEC-MR-RB-032)								
Rotation direction selection *4	PA14	0	1 (+ : Counter motors side)								
Load to motor inertia moment ratio	PB06	7	7								
Function selection E-3	PE41	0000	0000								

 Differs to initial value

- *1. Parameter is set to the recommended value. Please set parameter according to customer application.
- *2. Mechanical resonance may occur depending on the shape or mounting orientation of the work piece. Please change this parameter during initial configuration.
(Parameter initial configuration ⇒ Set the recommended parameter value ⇒ Operation start)
- *3. Minimum actuator travel distance of 1[μm].
- *4. When the motor mounting position is right side parallel (LEFS*R) or left side parallel (LEFS*L), the rotation direction selection is 0(+: Counter motors side).
- *5. When the home position return direction is the motor side of the actuator and the home position return method is the stopper type.

CAUTION

- When the stopper type home position return is used and the actuator end is set to the home position, please pay attention to the actuator movable range when commanding the position to prevent collision with both ends of the actuator due to overshoot.
- When the origin (0 mm) is set at the actuator end, the movable range of this actuator is from [+2mm] to [actuator stroke +2mm].

APPENDIX

Series			LEFB25	LEFB25U	LEFB32	LEFB32U	LEFB40	LEFB40U
	Lead symbol		S					
	Lead		54					
Parameter *1,*2	Para No	Initial value	Recommended value					
Electronic gear numerator *3.	PA0 6	1	4194304					
Electronic gear denominator *3.	PA0 7	1	54000					
Command mode selection *3	PT01	0300	0000					
Feel length multiplication (STM) (Multiplier)	PT03	0000	0000 (<1000 stroke)/0001 (>1000 stroke)					
Home position return method *4	PT45	37	-4	-36	-4	-36	-4	-36
Home position return Speed (rpm)	PT05	100	33					
Stopper type home position return stopper time (msec)	PT10	100	200					
Stopper type home position return torque limit value (%)	PT11	15	84					
Home position return acceleration time constant (msec)	PT56	0	2700					
Regenerative option	PA0 2	0000	0000 (Non)/0002 (LEC-MR-RB-032)					
Rotation direction selection	PA1 4	0	1 (+ : Counter motors side)	0 (+ : Counter motors side)	1 (+ : Counter motors side)	0 (+ : Counter motors side)	1 (+ : Counter motors side)	0 (+ : Counter motors side)
★ Load to motor inertia moment ratio	PB0 6	7	50					
★Function selection E-3	PE4 1	0000	0001(Robust filter enabled)					

★ Parameter setting required.

Differs to initial value

- *1. Parameter is set to the recommended value. Please set parameter according to customer application.
- *2. Mechanical resonance may occur depending on the shape or mounting orientation of the work piece.
Please change this parameter during initial configuration.
(Parameter initial configuration ⇒ Set the recommended parameter value ⇒ Operation start)
- *3. Minimum actuator travel distance of 1[μm].
- *4. When the home position return direction is the motor side of the actuator and the home position return method is the stopper type.

CAUTION

- When the stopper type home position return is used and the actuator end is set to the home position, please pay attention to the actuator movable range when commanding the position to prevent collision with both ends of the actuator due to overshoot.
- When the origin (0 mm) is set at the actuator end, the movable range of this actuator is from [+3mm] to [actuator stroke +3mm].

APPENDIX

Recommended Parameter Values [LEJ]

Series			LEJS40			LEJS63			LEJB40	LEJB63
	Lead symbol		H	A	B	H	A	B	T	
	Lead		24	16	8	30	20	10	27	42
Parameter *1,*2	Para. No	Initial value	Recommended value							
Electronic gear numerator *3.	PA06	1	4194304							
Electronic gear denominator *3.	PA07	1	24000	16000	8000	30000	20000	10000	27000	42000
Command mode selection *3	PT01	0300	0000							
Feel length multiplication (STM) (Multiplier)	PT03	0000	0000 (<1000 stroke)/0001 (>1000 stroke)							
Home position return method *4	PT45	37	-4						-36	
Home position return Speed (rpm)	PT05	100	75	113	225	60	90	180	133	86
Stopper type home position return stopper time (msec)	PT10	100	200							
Stopper type home position return torque limit value (%)	PT11	15	84							
Home position return acceleration time constant (msec)	PT56	0	1200	800	400	1500	1000	500	1350	2100
Regenerative option	PA02	0000	0000 (Non)/0002 (LEC-MR-RB-032)/0003 (LEC-MR-RB-12)							
Rotation direction selection	PA14	0	1 (+ : Counter motors side)						0 (+ : Counter motors side)	
★Load to motor inertia moment ratio	PB06	7	7						50	
★Function selection E-3	PE41	0000	0000						0001(Robust filter enabled)	

★ Parameter setting required.

Differs to initial value

*1. Parameter is set to the recommended value. Please set parameter according to customer application.

*2. Mechanical resonance may occur depending on the shape or mounting orientation of the work piece.
Please change this parameter during initial configuration.

(Parameter initial configuration ⇒ Set the recommended parameter value ⇒ Operation start)

*3. Minimum actuator travel distance of 1[μm].

*4. When the home position return direction is the motor side of the actuator and the home position return method is the stopper type.

CAUTION

- When the stopper type home position return is used and the actuator end is set to the home position, please pay attention to the actuator movable range when commanding the position to prevent collision with both ends of the actuator due to overshoot.
- When the origin (0 mm) is set at the actuator end, the movable range of this actuator is from [+2mm] to [actuator stroke +2mm].

APPENDIX

Series	Lead symbol		LEJS100		
	Lead		H	A	B
	Lead		50	25	10
Parameter *1,*2	Para. No	Initial value	Recommended value		
Electronic gear numerator *3.	PA06	1	4194304		
Electronic gear denominator *3.	PA07	1	50000	25000	10000
Command mode selection *3	PT01	0300	0000		
Feel length multiplication (STM) (Multiplier)	PT03	0000	0000 (<1000 stroke)/0001 (>1000 stroke)		
Home position return method *4	PT45	37	-4		
Home position return Speed (rpm)	PT05	100	36	72	180
Stopper type home position return stopper time (msec)	PT10	100	200		
Stopper type home position return torque limit value (%)	PT11	15	84		
Home position return acceleration time constant (msec)	PT56	0	2500	1250	500
Regenerative option	PA02	0000	0000 (Non)/0002 (LEC-MR-RB-032)/0003 (LEC-MR-RB-12)		
Rotation direction selection	PA14	0	1 (+ : Counter motors side)		
Load to motor inertia moment ratio	PB06	7	7		
Function selection E-3	PE41	0000	0001(Robust filter enabled)		

 : Differs to initial value

- *1. Parameter is set to the recommended value. Please set parameter according to customer application.
- *2. Mechanical resonance may occur depending on the shape or mounting orientation of the work piece.
Please change this parameter during initial configuration.
(Parameter initial configuration ⇒ Set the recommended parameter value ⇒ Operation start)
- *3. Minimum actuator travel distance of 1[μm].
- *4. When the home position return direction is the motor side of the actuator and the home position return method is the stopper type.

CAUTION

- When the stopper type home position return is used and the actuator end is set to the home position, please pay attention to the actuator movable range when commanding the position to prevent collision with both ends of the actuator due to overshoot.
- When the origin (0 mm) is set at the actuator end, the movable range of this actuator is from [+7mm] to [actuator stroke +7mm].

APPENDIX

Recommended Parameter Values [LEY]

Series	Lead symbol		LEY25/LEYG25			LEY25D/LEYG25D			LEY32/LEYG32			LEY32D/LEYG32D		
			A	B	C	A	B	C	A	B	C	A	B	C
			Lead	12	6	3	12	6	3	20	10	5	16	8
Parameter *1,*2	Para. No	Initial value	Recommended value											
Electronic gear numerator *3.	PA06	1	4194304											
Electronic gear denominator *3.	PA07	1	12000	6000	3000	12000	6000	3000	20000	10000	5000	16000	8000	4000
Command mode selection *3	PT01	0300	0000											
Feel length multiplication (STM) (Multiplier)	PT03	0000	0000 (<1000 stroke)/0001 (>1000 stroke)											
Home position return method *5	PT45	37	-36			-4			-36			-4		
Home position return Speed (rpm)	PT05	100	150	300	600	150	300	600	90	180	360	112	225	450
Stopper type home position return stopper time (msec)	PT10	100	200											
Stopper type home position return torque limit value (%)	PT11	15	84											
Home position return acceleration time constant (msec)	PT56	0	600	300	150	600	300	150	1000	500	250	800	400	200
Regenerative option	PA02	0000	0000 (Non)/0002 (LEC-MR-RB-032)											
Rotation direction selection *4	PA14	0	0 (+ : Counter motors side)			1 (+ : Counter motors side)			0 (+ : Counter motors side)			1 (+ : Counter motors side)		
Load to motor inertia moment ratio	PB06	7	7											
Function selection E-3	PE41	0000	0000											

 Differs to initial value

- *1. Parameter is set to the recommended value. Please set parameter according to customer application.
- *2. Mechanical resonance may occur depending on the shape or mounting orientation of the work piece. Please change this parameter during initial configuration.
(Parameter initial configuration ⇒ Set the recommended parameter value ⇒ Operation start)
- *3. Minimum actuator travel distance of 1[μm].
- *4. When the motor mounting position is right side parallel (LEY*R) or left side parallel (LEY*L), the rotation direction selection is 0(+: Counter motors side).
- *5. When the home position return direction is the motor side of the actuator and the home position return method is the stopper type.

CAUTION

- When the stopper type home position return is used and the actuator end is set to the home position, please pay attention to the actuator movable range when commanding the position to prevent collision with both ends of the actuator due to overshoot.
- When the origin (0 mm) is set at the actuator end, the movable range of this actuator is from [+2mm] to [actuator stroke +2mm].

APPENDIX

Series			LEY63				LEY63D			
	Lead symbol		A	B	C	L	A	B	C	
	Lead (Including pulley ratio)		20	10	5	5(2.86) (Pulley ratio 4/7)	20	10	5	
Parameter *1,*2	Para. No	Initial value	Recommended value							
Electronic gear numerator *3.	PA06	1	4194304				1835008	4194304		
Electronic gear denominator *3.	PA07	1	20000	10000	5000	1250	20000	10000	5000	
Command mode selection *3	PT01	0300	0000							
Feel length multiplication (STM) (Multiplier)	PT03	0000	0000 (<1000 stroke)/0001 (>1000 stroke)							
Home position return method *5	PT45	37	-36				-4			
Home position return Speed (rpm)	PT05	100	90	180	360	629	90	180	360	
Stopper type home position return stopper time (msec)	PT10	100	200							
Stopper type home position return torque limit value (%)	PT11	15	84							
Home position return acceleration time constant (msec)	PT56	0	1000	500	250	143	1000	500	250	
Regenerative option	PA02	0000	0000 (Non)/0002 (LEC-MR-RB-032)/0003 (LEC-MR-RB-12)							
Rotation direction selection *4	PA14	0	0 (+ : Counter motors side)				1 (+ : Counter motors side)			
Load to motor inertia moment ratio	PB06	7	7							
Function selection E-3	PE41	0000	0000							

 Differs to initial value

- *1. Parameter is set to the recommended value. Please set parameter according to customer application.
- *2. Mechanical resonance may occur depending on the shape or mounting orientation of the work piece. Please change this parameter during initial configuration.
(Parameter initial configuration ⇒ Set the recommended parameter value ⇒ Operation start)
- *3. Minimum actuator travel distance of 1[μm].
- *4. When the motor mounting position is right side parallel (LEY*R) or left side parallel (LEY*L), the rotation direction selection is 0(+: Counter motors side).
- *5. When the home position return direction is the motor side of the actuator and the home position return method is the stopper type.

CAUTION

- When the stopper type home position return is used and the actuator end is set to the home position, please pay attention to the actuator movable range when commanding the position to prevent collision with both ends of the actuator due to overshoot.
- When the origin (0 mm) is set at the actuator end, the movable range of this actuator is from [+4mm] to [actuator stroke +4mm].

APPENDIX

Series	Lead symbol		LEY100			LEY100D		
	Lead		B	D	L	B	D	L
	(Including pulley ratio)		10	10 (3.3) (Pulley ratio 1/3)	10 (2) (Pulley ratio 1/5)	10	10 (3.3) (Pulley ratio 1/3)	10 (2) (Pulley ratio 1/5)
Parameter *1,*2	Para. No	Initial value	Recommended value					
Electronic gear numerator *3.	PA06	1	4194304	12582912	4194304	4194304	12582912	4194304
Electronic gear denominator *3.	PA07	1	10000	10000	2000	10000	10000	2000
Command mode selection *3	PT01	0300	0000					
Feel length multiplication (STM) (Multiplier)	PT03	0000	0000 (<1000 stroke)/0001 (>1000 stroke)					
Home position return method *4	PT45	37	-36			-4		
Home position return Speed (rpm)	PT05	100	180	545	900	180	545	900
Stopper type home position return stopper time (msec)	PT10	100	200					
Stopper type home position return torque limit value (%)	PT11	15	84					
Home position return acceleration time constant (msec)	PT56	0	500	166	100	500	166	100
Regenerative option	PA02	0000	0000 (Non)/0002 (LEC-MR-RB-032)/0003 (LEC-MR-RB-12)					
Rotation direction selection *5	PA14	0	0 (+ : Counter motors side)			1 (+ : Counter motors side)		
Load to motor inertia moment ratio	PB06	7	7					
Function selection E-3	PE41	0000	0001(Robust filter enabled)					

: Differs to initial value

- *1. Parameter is set to the recommended value. Please set parameter according to customer application.
- *2. Mechanical resonance may occur depending on the shape or mounting orientation of the work piece. Please change this parameter during initial configuration.
(Parameter initial configuration ⇒ Set the recommended parameter value ⇒ Operation start)
- *3. Minimum actuator travel distance of 1[μm].
- *4. When the home position return direction is the motor side of the actuator and the home position return method is the stopper type.
- *5. When the motor mounting position is right side parallel (LEY*R) or left side parallel (LEY*L), the rotation direction selection is 0(+: Counter motors side).

CAUTION

- When the stopper type home position return is used and the actuator end is set to the home position, please pay attention to the actuator movable range when commanding the position to prevent collision with both ends of the actuator due to overshoot.
- When the origin (0 mm) is set at the actuator end, the movable range of this actuator is from [+5mm] to [actuator stroke +5mm].

APPENDIX

Recommended Parameter Values [LESYH]

Series	Lead symbol		LESYH16		LESYH16D		LESYH25		LESYH25D	
	Lead		A	B	A	B	A	B	A	B
	(Including pulley ratio)		10	6	10	6	16 (20) (Pulley ratio 5/4)	8 (10) (Pulley ratio 5/4)	16	8
Parameter *1,*2	Para. No	Initial value	Recommended value							
Electronic gear numerator *3.	PA06	1	4194304							
Electronic gear denominator *3.	PA07	1	10000	6000	10000	6000	20000	10000	16000	8000
Command mode selection *3	PT01	0300	0000							
Feel length multiplication (STM) (Multiplier)	PT03	0000	0000 (<1000 stroke)/0001 (>1000 stroke)							
Home position return method *5	PT45	37	-36		-4		-36		-4	
Home position return Speed (rpm)	PT05	100	180	300	180	300	90	180	112	225
Stopper type home position return stopper time (msec)	PT10	100	200							
Stopper type home position return torque limit value (%)	PT11	15	84							
Home position return acceleration time constant (msec)	PT56	0	500	300	500	300	1000	500	800	400
Regenerative option	PA02	0000	0000 (Non)/0002 (LEC-MR-RB-032)							
Rotation direction selection *4	PA14	0	0 (+ : Counter motors side)		1 (+ : Counter motors side)		0 (+ : Counter motors side)		1 (+ : Counter motors side)	
Load to motor inertia moment ratio	PB06	7	7							
Function selection E-3	PE41	0000	0000							

: Differs to initial value

- *1. Parameter is set to the recommended value. Please set parameter according to customer application.
- *2. Mechanical resonance may occur depending on the shape or mounting orientation of the work piece. Please change this parameter during initial configuration.
(Parameter initial configuration ⇒ Set the recommended parameter value ⇒ Operation start)
- *3. Minimum actuator travel distance of 1[μm].
- *4. When the motor mounting position is right side parallel (LESYH*R) or left side parallel (LESYH*L), the rotation direction selection is 0(+: Counter motors side).
- *5. When the home position return direction is the motor side of the actuator and the home position return method is the stopper type.

CAUTION

- When the stopper type home position return is used and the actuator end is set to the home position, please pay attention to the actuator movable range when commanding the position to prevent collision with both ends of the actuator due to overshoot.
- When the origin (0 mm) is set at the actuator end, the movable range of this actuator is from [+2mm] to [actuator stroke +2mm].

APPENDIX

Recommended Parameter Values [LET]

Series			LET80			LET100			
	Lead symbol		D	L	M	D	L	M	N
	Lead (Including pulley ratio)		130(43.3) Pulley ratio 1/3	130(26) Pulley ratio 1/5	130(14.4) Pulley ratio 1/9	240(80) Pulley ratio 1/3	240(48) Pulley ratio 1/5	240(26.7) Pulley ratio 1/9	240(16) Pulley ratio 1/15
Parameter *1,*2	Para. No	Initial value	Recommended Parameter Values						
Electron gear number *3	PA06	1	4718592			196608			
Electron gear denominator *3	PA07	1	48750	29250	16250	3750	2250	1250	750
Command mode select *3	PT01	0300	0000						
Feel length multiplication (STM)(Multiplier)	PT03	0000	0000(<1000stroke) / 0001(>1000stroke)						
Home position return method *4	PT45	37	-4: Motor arrangement RL,FR -36: Motor arrangement RR,FL						
Home position return speed (rpm)	PT05	100	42	69	125	23	38	68	113
Stopper type home position return stopper time (msec)	PT10	100	200						
Stopper type home position return torque limit value (%)	PT11	15	84	54	30	84	84	70	42
Home position return acceleration time constant (msec)	PT56	0	2167	1300	722	4000	2400	1333	800
Regenerative option	PA02	0000	0000(Non) / 0002(LEC-MR-RB-032) / 0003(LEC-MR-RB-12) / 0004(LEC-MR-RB-32)						
Rotation direction selection	PA14	0	1 : Motor arrangement RL,FR 0: Motor arrangement RR,FL						
Auto-tuning Responsiveness *5	PA09	16	16						
★Load to motor inertia Moment ratio	PB06	7	50						
★Function selectionE-3	PE41	0000	0001(Robust filter enabled)						

: Differs to initial value

★ : Parameter change required

- *1. Parameter is set to the recommended value. Please set parameter according to customer application.
- *2. Mechanical resonance may occur depending on the shape or mounting orientation of the work piece. Please change this parameter during initial configuration.
(Parameter initial configuration ⇒ Set the recommended parameter value ⇒ Operation start)
- *3. Minimum actuator travel distance of 1[μm].
- *4. When the home position return direction is the motor side of the actuator and the home position return method is the stopper type.
- *5. Since the response of acceleration/deceleration may vary depending on the shape of the object to be conveyed and its installation condition, please make adjustments in the parameters.
If the response is set too high, oscillation may occur.

CAUTION

- When the stopper type home position return is used and the actuator end is set to the home position, please pay attention to the actuator movable range when commanding the position to prevent collision with both ends of the actuator due to overshoot.
- When the origin (0 mm) is set at the actuator end, the movable range of this actuator is follow,
For LET80, from [+22mm] to [actuator stroke +22mm].
For LET100, from [+25mm] to [actuator stroke +25mm].

Revision history

SMC Corporation

Tel: + 81 3 5207 8249 Fax: +81 3 5298 5362

URL <https://www.smcworld.com>

Note: Specifications are subject to change without prior notice and any obligation on the part of the manufacturer.
© SMC Corporation All Rights Reserved

