



Operation Manual

PRODUCT NAME

***Programless controller (with stroke study)
Step motor (servo 24 VDC)***

MODEL / Series / Product Number

LECP2 Series



SMC Corporation

1. Safety Instructions	4
2. Product Outline	6
2.1 Product features	6
2.2 Product configuration.....	7
2.3 How to Order	8
2.4 Option	9
(1) Actuator cable (5m or less)	9
(2) Actuator cable (8-20m).....	9
(3) Actuator cable for with lock and sensor (5m or less)	10
(4) Actuator cable for with lock and sensor (8-20m).....	10
2.5 Startup Procedures	11
(1) Confirmation of the package content.....	11
(2) Installation.....	11
(3) Wiring and connection.....	11
(4) Power ON alarm (error).....	12
(5) Stroke study	12
(6) Registering of the stopping position	12
(7) Operation check	12
(8) The operation of the electric actuator.....	12
3. Product Specifications	13
3.1 Basic specifications.....	13
3.2 Parts description	14
3.3 Outside dimension diagramm.....	15
3.4 How to install	16
(1) How to install	16
(2) Ground wire connection	16
(3) Installation location.....	17
4. External Wiring Diagram	18
4.1 CN1: Power supply cable	18
4.2 CN2: Motor power connector and CN3: Encoder connector.....	18
4.3 CN4: Parallel I/O connector	18
5. CN1: Power supply cable	19
5.1 Power supply cable specifications.....	19
5.2 Wiring of power supply cable	19
(1) Wiring of the power supply	19

(2) Wiring of the lock release	20
(3) Stop the power supply for the motor	20
6. CN4: Parallel I/O Connector	22
6.1 Parallel I/O specifications.....	22
6.2 Parallel I/O type (NPN / PNP type)	22
(1) Parallel I/O input circuit (same for both NPN and PNP type).....	22
(2) Parallel I/O output circuit	22
6.3 Details of parallel input / output signal and cable	23
(1) Parallel I/O cable(LEC-CK4-□)	23
(2) Derails of input / Output signal	23
(3) The change of I/O output signal.....	25
6.4 Parallel I/O Wiring Example.....	26
7. Setting method.....	27
7.1 Setting procedure.....	28
(1) Supply of power.....	28
(2) Changes to Manual mode.....	28
(3) Stroke study	28
(4) Test run	30
(5) Setting of Speed and Acceleration	30
(6) Completion of setting.....	30
(7) Intermediate position setting	31
7.2 Setting of the speed and the acceleration.....	35
7.3 Setting parameters	36
8. Operations.....	39
8.1 Return to origin.....	39
(1) Return to origin operation	39
(2) How to command the return to origin	40
8.2 Positioning operation	41
8.3 Jog operation / inching operation	42
(1) Jog operation	42
(2) Inching operation	42
8.4 Servo ON	43
8.5 Response time for the controller input signal	43
9. Operation instruction	44
9.1 Operation instruction overview	44
(1) Return to origin.....	44
(2) The command to drive to the stroke end and the intermediate position....	44
(3) Stop.....	44

9.2 Operating procedure of parallel I/O	45
(1) Power on → Return to origin.....	45
(2) Positioning operation : Driving to the stroke end and Driving to the intermediate position	46
(3) Reset : Reset of the driving and Reset of the alarm	47
(4) STOP	47
10. Initial setting value of electric actuator (LEM series)	48
11. Alarm Detection.....	49
11.1 Alarm group output	49
11.2 Alarm details	50
12. Wiring of cables / Common precautions	53
13. Electric actuators / Common precautions	54
13.1 Design and selection	54
13.2 Mounting	55
13.3 Precautions for Use	55
13.4 Operating environment.....	57
13.5 Maintenance.....	57
13.6 Precautions for electric actuator with lock	58
14. Controller and its peripheral devices / Specific product precautions	59
14.1 Design and selection	59
14.2 Handling	59
14.3 Installation.....	60
14.4 Wiring.....	60
14.5 Power supply	61
14.6 Grounding	61
14.7 Maintenance and inspection	61
15. Troubleshooting.....	62



LECP2 Series / Controller

1. Safety Instructions

These safety instructions are intended to prevent hazardous situations and/or equipment damage. These instructions indicate the level of potential hazard with the labels of “**Caution**,” “**Warning**” or “**Danger**.” They are all important notes for safety and must be followed in addition to International Standards (ISO/IEC)^{*1)}, and other safety regulations.

*1) ISO 4414: Pneumatic fluid power - General rules and safety requirements for systems and their components
ISO 4413: Hydraulic fluid power - General rules and safety requirements for systems and their components
IEC 60204-1: Safety of machinery - Electrical equipment of machines - Part 1: General requirements
ISO 10218-1: Robots and robotic devices - Safety requirements for industrial robots - Part 1: Robots
etc.



Danger

Danger indicates a hazard with a high level of risk which, if not avoided, will result in death or serious injury.



Warning

Warning indicates a hazard with a medium level of risk which, if not avoided, could result in death or serious injury.



Caution

Caution indicates a hazard with a low level of risk which, if not avoided, could result in minor or moderate injury.



Warning

1. The compatibility of the product is the responsibility of the person who designs the equipment or decides its specifications.

Since the product specified here is used under various operating conditions, its compatibility with specific equipment must be decided by the person who designs the equipment or decides its specifications based on necessary analysis and test results. The expected performance and safety assurance of the equipment will be the responsibility of the person who has determined its compatibility with the product. This person should also continuously review all specifications of the product referring to its latest catalog information, with a view to giving due consideration to any possibility of equipment failure when configuring the equipment.

2. Only personnel with appropriate training should operate machinery and equipment.

The product specified here may become unsafe if handled incorrectly. The assembly, operation and maintenance of machines or equipment including our products must be performed by an operator who is appropriately trained and experienced.

3. Do not service or attempt to remove product and machinery/equipment until safety is confirmed.

1. The inspection and maintenance of machinery/equipment should only be performed after measures to prevent falling or runaway of the driven objects have been confirmed.
2. When the product is to be removed, confirm that the safety measures as mentioned above are implemented and the power from any appropriate source is cut, and read and understand the specific product precautions of all relevant products carefully.
3. Before machinery/equipment is restarted, take measures to prevent unexpected operation and malfunction.

4. SMC products cannot be used beyond their specifications. They are not developed, designed, and manufactured to be used under the following conditions or environments. Use under such conditions or environments is not allowed.

1. Conditions and environments outside of the given specifications, or use outdoors or in a place exposed to direct sunlight.
2. Use for nuclear power, railways, aviation, space equipment, ships, vehicles, military application, equipment affecting human life, body, and property, combustion equipment, entertainment equipment, emergency shut-off circuits, press clutches, brake circuits, safety equipment, etc., and use for applications that do not conform to standard specifications such as catalogs and operation manuals.
3. Use for interlock circuits, except for use with double interlock such as installing a mechanical protection function in case of failure. Please periodically inspect the product to confirm that the product is operating properly.



LECP2 Series / Controller

1. Safety Instructions

Caution

SMC develops, designs, and manufactures products to be used for automatic control equipment, and provides them for peaceful use in manufacturing industries.

Use in non-manufacturing industries is not allowed.

Products SMC manufactures and sells cannot be used for the purpose of transactions or certification specified in the Measurement Act of each country.

The new Measurement Act prohibits use of any unit other than SI units in Japan.

Limited warranty and Disclaimer/Compliance Requirements

The product used is subject to the following “Limited warranty and Disclaimer” and “Compliance Requirements”.

Read and accept them before using the product.

Limited warranty and Disclaimer

1. The warranty period of the product is 1 year in service or 1.5 years after the product is delivered, whichever is first.*2)
Also, the product may have specified durability, running distance or replacement parts. Please consult your nearest sales branch.
2. For any failure or damage reported within the warranty period which is clearly our responsibility, a replacement product or necessary parts will be provided.
This limited warranty applies only to our product independently, and not to any other damage incurred due to the failure of the product.
3. Prior to using SMC products, please read and understand the warranty terms and disclaimers noted in the specified catalog for the particular products.

***2) Vacuum pads are excluded from this 1 year warranty.**

A vacuum pad is a consumable part, so it is warranted for a year after it is delivered.

Also, even within the warranty period, the wear of a product due to the use of the vacuum pad or failure due to the deterioration of rubber material are not covered by the limited warranty

Compliance Requirements

1. The use of SMC products with production equipment for the manufacture of weapons of mass destruction (WMD) or any other weapon is strictly prohibited.
2. The exports of SMC products or technology from one country to another are governed by the relevant security laws and regulations of the countries involved in the transaction. Prior to the shipment of a SMC product to another country, assure that all local rules governing that export are known and followed.

2. Product Outline

2.1 Product features

The followings are the main functions of this controller:

- Electric actuator control

Positioning operation and operation at a specific speed for the electric actuator are possible by controlling the Step motor (servo 24 VDC).

- Operation and settings are available with the controller.

Settings can be altered and operation can be run from the controller. Adjustments of the position, speed, acceleration and test runs are available without the teaching box, PC, and PLC.

- Power supply separation input

The power input is separated into two systems of motor power supply and control power supply, and when the control power supply is on while the power supply is off, the parallel I/O control is not lost without losing the position information of the encoder is possible.

- Positioning of 12 intermediate points and both stroke end points are possible.

According to the combination of parallel I/O inputs, it is possible to perform positioning operation of 12 points (position numbers 3 to 14 (E)) and positioning operation to the stroke end point (two points on the end side and the motor side).

In addition, it is possible to set the speed and the acceleration by the switch for each driving direction.

- Stroke study

By the stroke study, LEC-6 controller recognizes the possible moving area and registers both stroke end points automatically.

Just after the controller is delivered and after adjusting the stopper of the electric actuator, the stroke study must be performed.

Caution

- When the power is turned on immediately after purchasing the controller, the ALM LED of the controller blinks in red because the stroke learning has not been performed yet. When stroke learning is executed, the ALM LED goes out.
- When executing stroke learning, the registration position of all intermediate positions will be changed so be sure to re-register all intermediate positions (position numbers 3 to 14 (E)).

- Automatic sequence function of the return to origin position

When power is applied to the LECP2 controller stroke study is performed and return to origin to the commanded side is possible when the first command of driving to stroke end is executed. (A dedicated signal for return to origin is not required.)

- Alarm detection function

Abnormal conditions are self-detected. Alarms are displayed by LED on the controller and abnormal conditions are output to the parallel I/O terminal.

Caution

Please keep this manual safe for future use. It will be necessary to refer to this manual along with the operation manuals for other electric actuators, teaching box, and controller setting kit at installation and fault finding.

Keep this operation manual accessible for reference.

2.2 Product configuration

The product configuration of this controller is as follows.

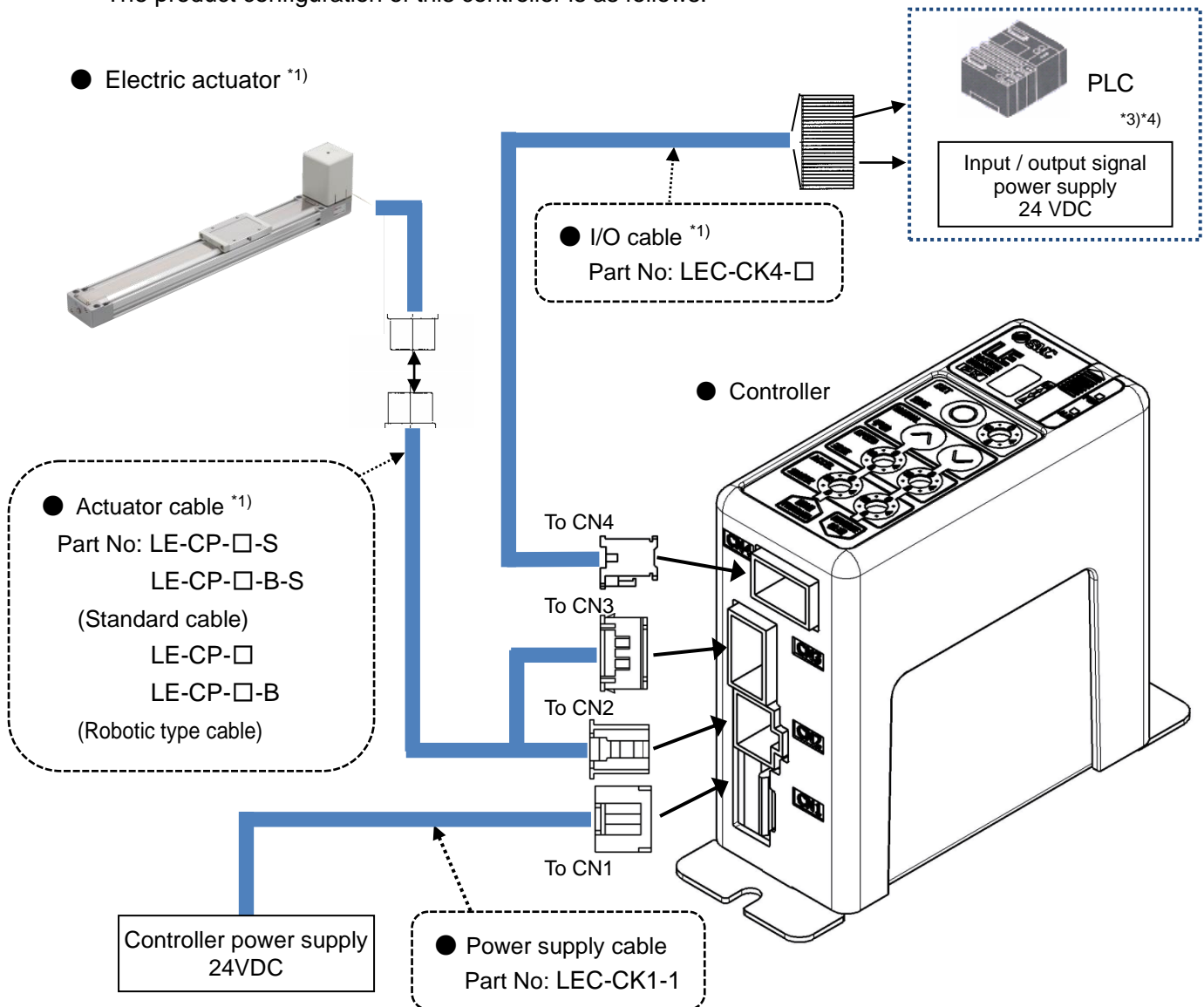

*1) These items are included when ordered using the part number for an electric actuator set.

*2) When conformity to UL is required, the electric actuator and controller should be used with a UL1310 Class 2 power supply.

Warning

Refer to “4. External Connection for wiring”

Refer to “12. Precautions for wiring and cables” when handling the wiring and cables.

2.3 How to Order

The part number construction for this product is as follows:

Controller

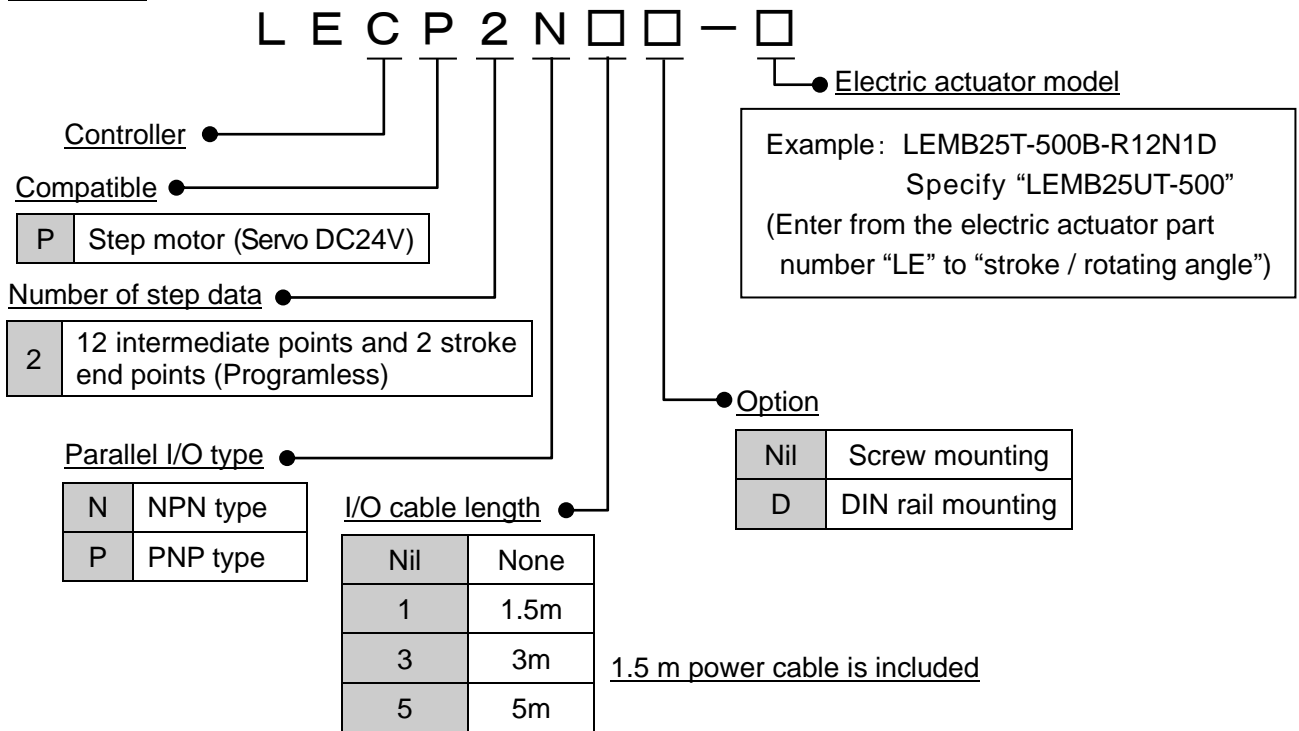

Electric actuator + Controller

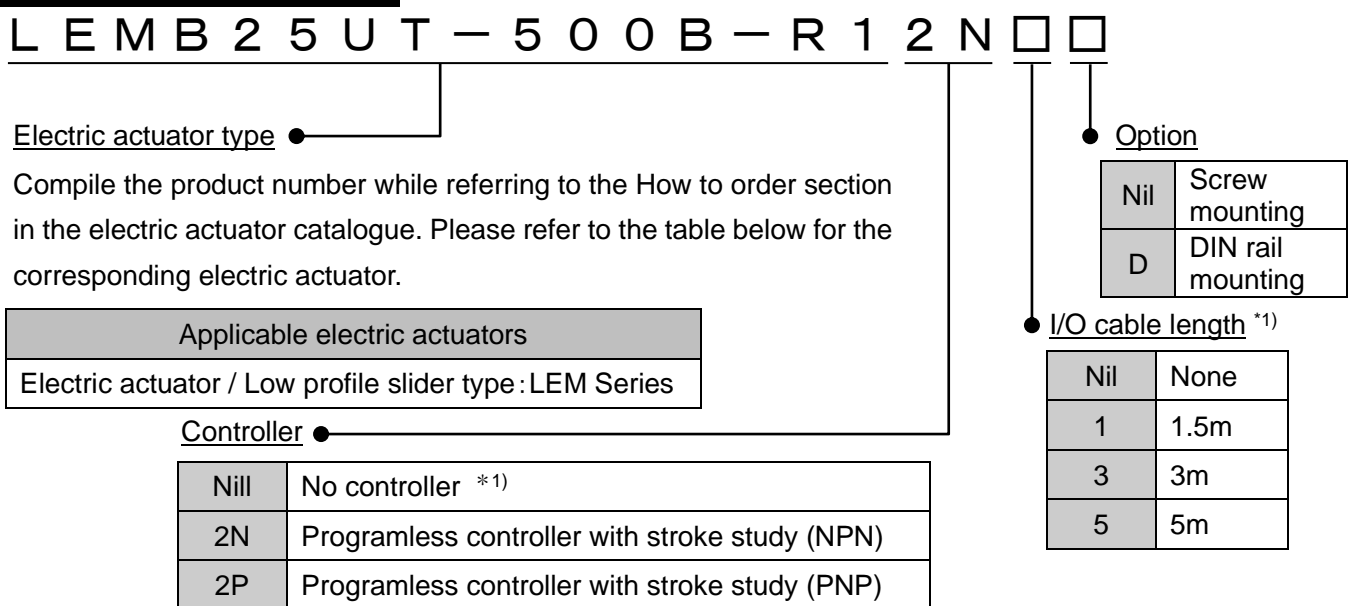

*1) An I/O cable cannot be specified for the electric actuator without a controller.

The LECP6 series I/O cable cannot be used because the specifications are different.

⚠ Caution

Single controllers are also shipped after setting the electric actuator specification parameters. Check that the combination of the controller and the electric actuator is correct before use.

2.4 Option

(1) Actuator cable (5m or less)

LE-CP-□-□

Cable length (L)

1	1.5m
3	3m
5	5m

Actuator cable type

Nil	Robotic type cable
S	Standard cable

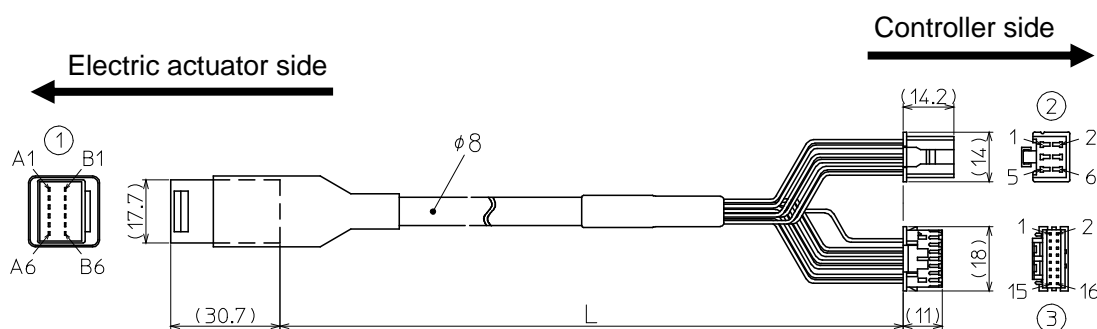
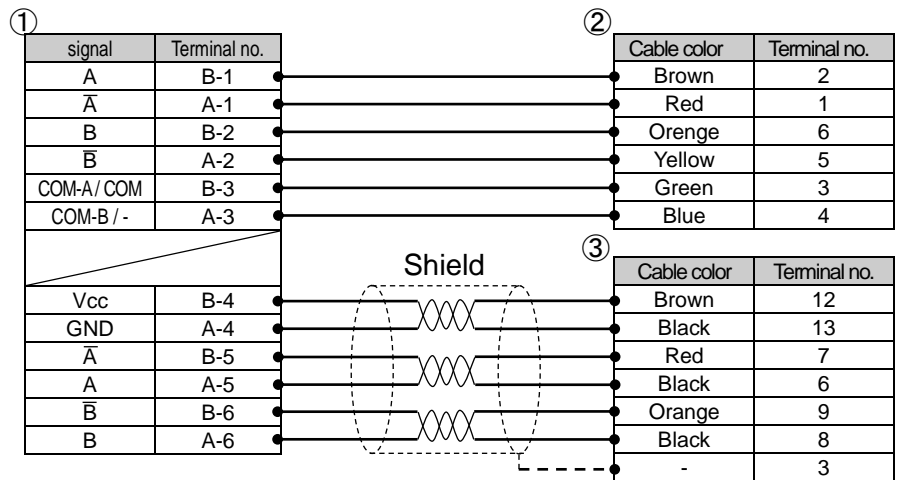

(2) Actuator cable (8-20m)

LE-CP-□

Cable length (L)

8	8m ^{*1)}
A	10m ^{*1)}
B	15m ^{*1)}
C	20m ^{*1)}

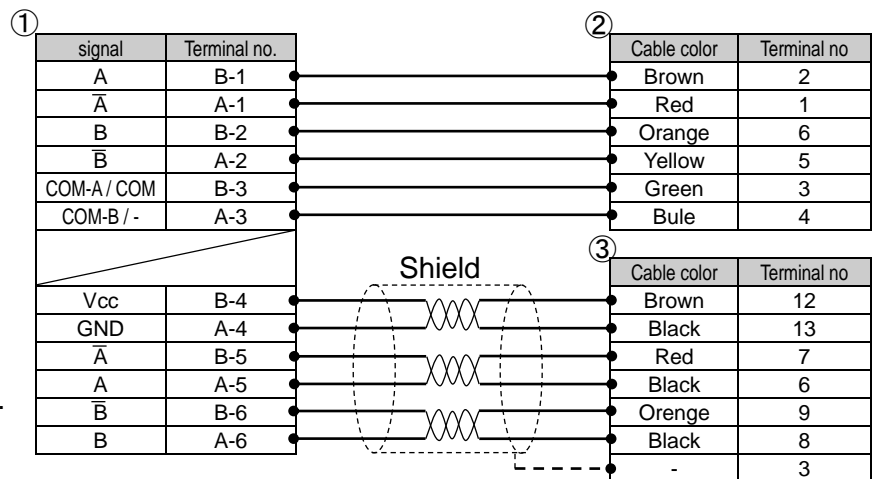

*1) Produced upon receipt of order.
Only Robotic type cable can be selected.

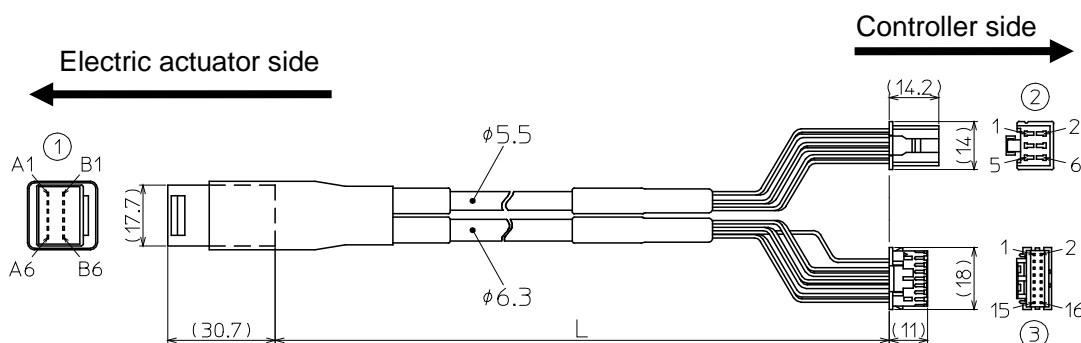

(3) Actuator cable for with lock and sensor (5m or less)

LE-CP-□-B-□ ①

Cable length (L)

1	1.5m
3	3m
5	5m

Actuator cable type

Nil	Robotic type cable
S	Standard cable

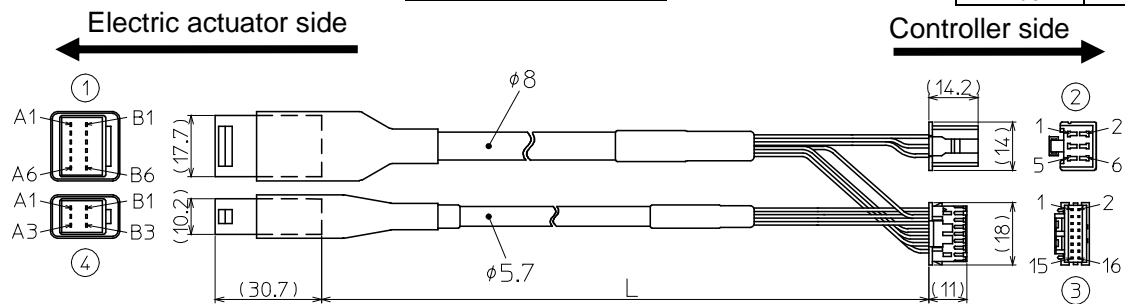
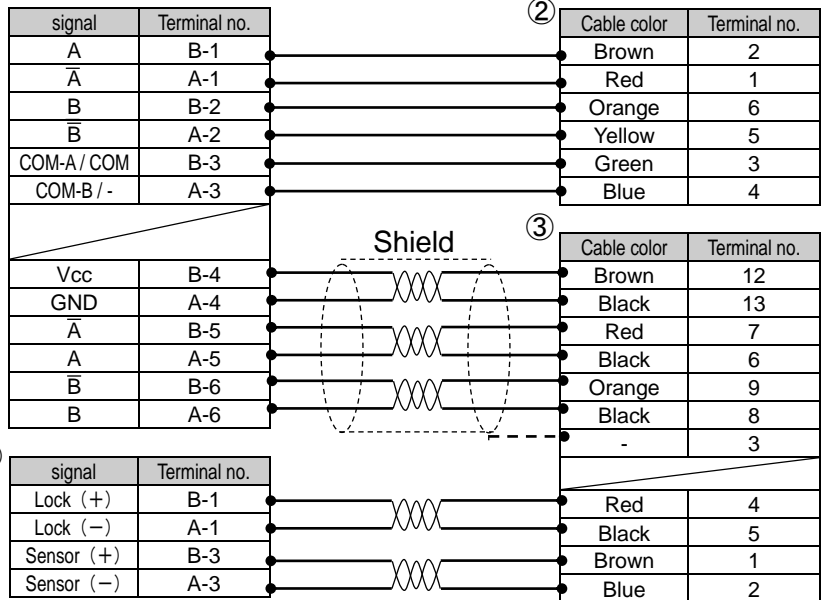

(4) Actuator cable for with lock and sensor (8-20m)

LE-CP-□-B ①

Cable length (L)

8	8m *1)
A	10m *1)
B	15m *1)
C	20m *1)

*1) Produced upon receipt of order.
Only Robotic type cable can be selected.

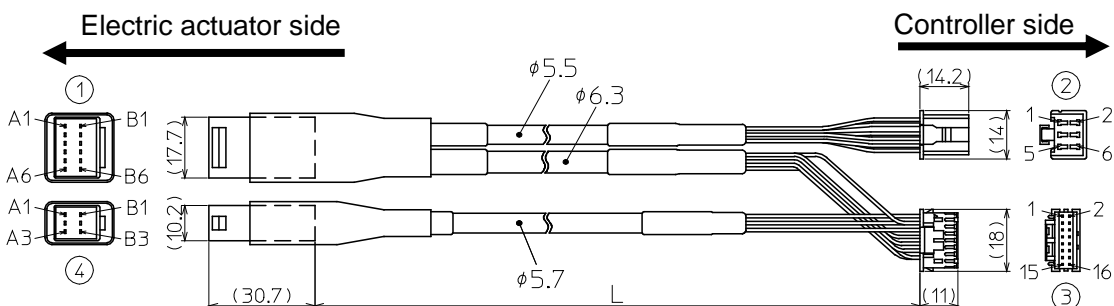
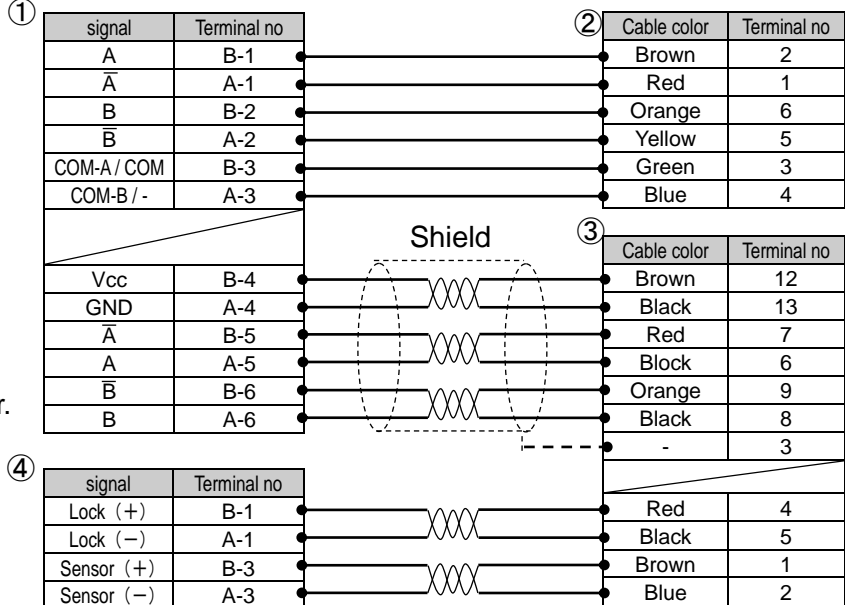

2.5 Startup Procedures

Be sure to check the procedure below before use.

(1) Confirmation of the package content

After unpacking everything, check the description on the label to identify the controller and the number of accessories. If any parts are missing or damaged, please contact your distributor.

Item	Quantity
Controller (LECP2□□-□)	1 unit
Power supply cable (LEC-CK1-1)	1 piece
I/O cable (LEC-CK4-□)	1 piece

*1) Included in the package only when the I/O cable length is specified.

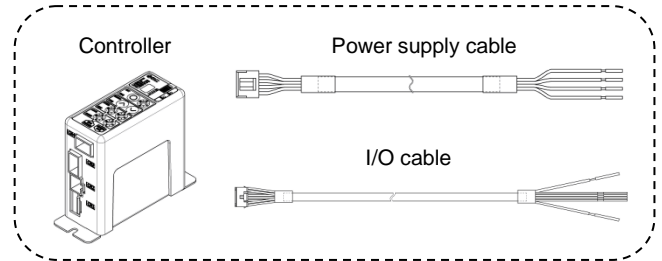

【Option】

- Actuator cable

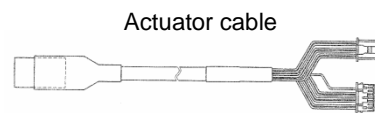

(2) Installation

Please refer to “3.4 How to install”

(3) Wiring and connection

Connect cables, etc. to the connector (CN1 to CN4) of the controller.

Please refer to “4 External Wiring Diagram” for the wiring of the connectors.

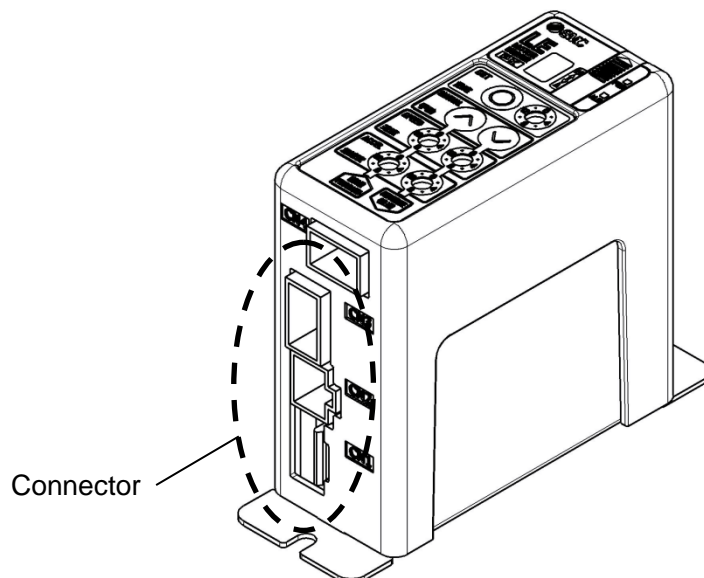

(4) Power ON alarm (error)

Supply 24 VDC power supply.

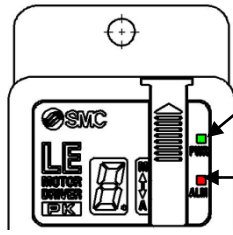

Controller

Function	LED turns on	Status
PWR	Green LED is ON	Servo is turned on
	Green LED is flashing	Servo is turned off
ALARM	Red LED is ON	Alarm is generated
	Red LED is flashing	Stroke study is not completed (Only when the power is supplied for the first time after the purchase)

Under normal conditions, the LED [PWR] on the front of the controller changes from a flashing to a solid light.

The servo will be turned ON if the conditions are normal.

When the LED [ALM] on the front of the controller is ON red, an alarm is generated.

When the power is supplied to the controller just after it is delivered, ALM LED of the controller flashes in red because Stroke study is not completed.

Therefore, in this case, it is necessary to perform Stroke study.

Caution

If an alarm is generated, check the content of the alarm using the 7-segment LED on the controller or I/O output, and eliminate the cause while referring to section “**11. Alarm Detection**”.

(5) Stroke study

The stroke study is performed with the buttons and the switches on the controller.

A stroke study of the controller must be performed immediately after purchase or adjustment of the electric actuator stopper.

Refer to “**7.1(3) Stroke study**” for details.

(6) Registering of the stopping position

The stopping position, speed and acceleration and deceleration are registered with the buttons and switches on the controller. Refer to “**7.1(7) Registering of the intermediate position**” for details.

(7) Operation check

The operation of the electric actuator is tested by the test run.

The test run is performed with the buttons and the switches on the controller.

Refer to “**7.1(4) Test run**” for details.

(8) The operation of the electric actuator

Change the mode to auto mode using the controller switch. Electric actuator can be operated by external equipment (PLC, etc.). Refer to “**9. Operation instruction**” for details.

3. Product Specifications

3.1 Basic specifications

The basic specifications of this controller are as follows:

Item	Specifications
Compatible motor	Unipolar winding method 2-Phase HB step motor
Power supply *1)	Power voltage: 24 VDC +/-10% *2) When conformity to UL is required, use UL1310 compliant Class 2 power supply unit for direct current.
Parallel input	6 inputs (photo-coupler isolation)
Parallel output	6 outputs (photo-coupler isolation)
Stop points	Stroke ends 2 points (Position number 1 and 2), Intermediate position 12 points (Position number 3 to 14(E)) (Stroke end (Position number 1 and 2) cannot be changed)
Compatible encoder	Incremental A / B phase (800 pulse / rotation)
Memory	EEPROM
LED indicator	2 of LED's (green and red)
7-segment LED display *3)	1 digit, 7-segment display (red) Figures are expressed in hexadecimal (10 to 15 in decimal number are expressed as A to F)
Lock control	Forced-lock release terminal (Applicable to non -magnetizing lock.)
Cable length	I/O cable: 5m or less Actuator cable: 20m or less
Cooling system	Natural air cooling
Operating temperature range	0 to 40°C (No freezing)
Operating humidity range	90%RH or less (No condensation)
Storage temperature	-10 to 60°C (No freezing)
Storage humidity range	90%RH or less (No condensation)
Insulation resistance	Between external terminals and case
Mass	130 g (screw mount type) 150 g (DIN rail mount type)

*1) Do not use the inrush current suppression type power supply for the controller power (24VDC).

*2) The power consumption changes depending on the electric actuator model.

Please refer to the specifications of the electric actuator for more details.

*3) "10" to "15" in decimal number are displayed as follows in the 7-segment LED.

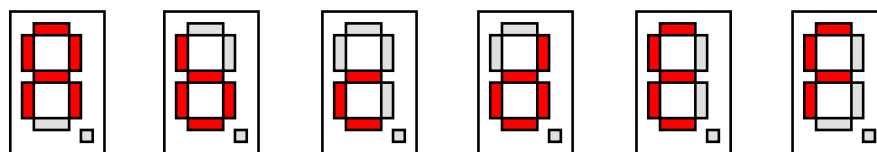

Decimal display

10

11

12

13

14

15

Hexadecimal display

A

b

c

d

E

F

3.2 Parts description

The detailed descriptions of each part are as follows:

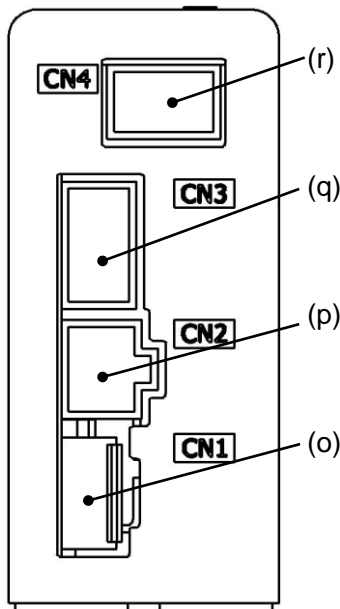
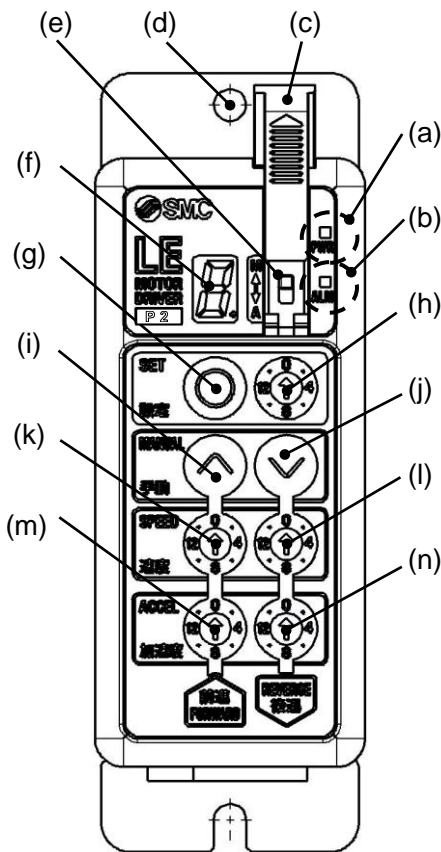

No.	Display	Description	Details
(a)	PWR	Power supply LED	Power supply ON / Servo ON: Green turns on Power supply ON / Servo OFF: Green flashes
(b)	ALM	Alarm LED	Power supply ON / With alarm: Red flashes Power supply ON / Un-performing of Stroke study :Flashes in red Power supply ON / Parameter setting: Red flashes
(c)	—	Cover	Protection of the mode switch changing. (Close the cover after changing switch).
(d)	—	FG	Frame ground (Tighten the bolt with the nut when mounting the controller. Connect the grounding wire.)
(e)	—	Mode switch	Switch the mode between manual and auto.
(f)	—	7-segment LED	Auto mode / Without alarm: Indicates the position number which is command by ON/OFF of IN0 to IN3 of the CN4 parallel I/O. (During command operation: Flashing / Instruction command completed: ON) Auto mode / With alarm: Indicates Alarm Group. Manual mode: Indicates that content may vary depending on the operating function.
(g)	SET	Set button	Determines the settings and gives a command to operate in manual mode.
(h)	—	Position switch	Assigns the position to drive (1 to 14).
(i)	MAN	Forward button	Performs forward jog and inching.
(j)	UAL	Reverse button	Performs reverse jog and inching.
(k)	SPEED	Forward speed switch	16 forward speeds are available. *1)
(l)		Reverse speed switch	16 reverse speeds are available. *1)
(m)	ACCEL	Forward acceleration switch	16 forward acceleration steps are available. *1)
(n)		Reverse acceleration switch	16 reverse acceleration steps are available. *1)
(o)	CN1	Power supply connector	Connect the power supply cable.
(p)	CN2	Motor driving connector	Connect motor connector of actuator cable.
(q)	CN3	Encoder connector	Connect encoder connector of actuator cable.
(r)	CN4	I/O connector	Connect I/O cable.

*1) The Set value of speed and acceleration are set for reverse and forward directions.

The set value will be reflected in the operation of all position numbers.

⚠ Caution

Use a flat blade watchmaker's screwdriver of the size shown below when changing position switch (h) and the set value of the speed / acceleration switches (k) to(n)

<Size>

End width L : 2.0 to 2.4 [mm]

End thickness W : 0.5 to 0.6 [mm]

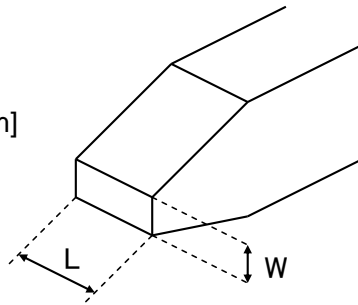

Magnified view of the end of the flat blade screwdriver

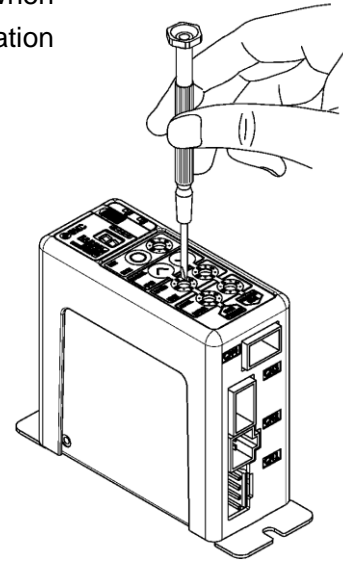

3.3 Outside dimension diagramm

The outside view of this product is as shown in the diagram below:

(1) Screw mount type
(LECP2□□-□)

(2) DIN rail mount type
(LECP2□□D-□)

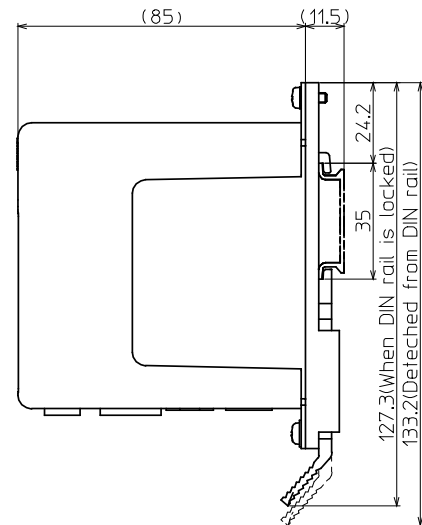
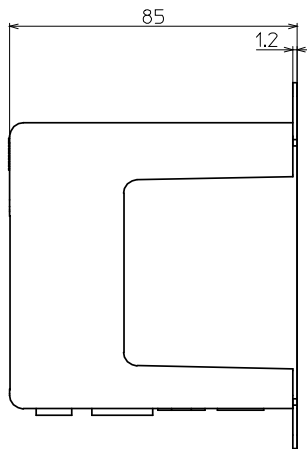
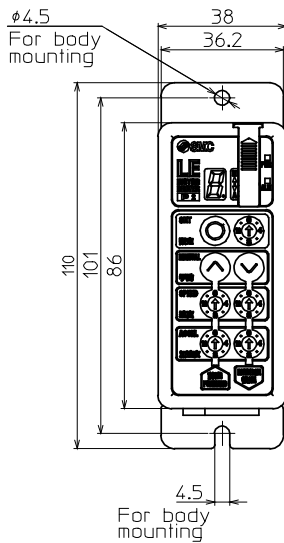

3.4 How to install

(1) How to install

The followings are the descriptions on how to install each type:

1) Screw mounting (LECP2□□-□)

(Installation with two M4 screws)

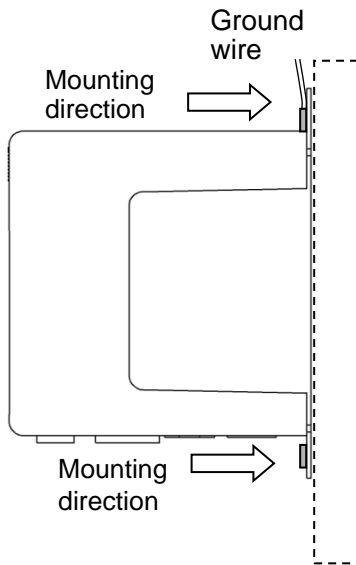

2) DIN rail mounting (LECP2□□D-□)

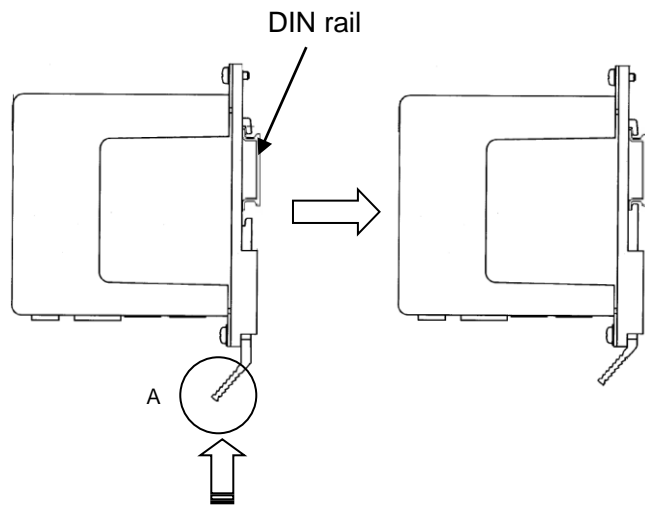

Hook the controller on the DIN rail and press the lever of section A in the arrow direction to lock it.

(2) Ground wire connection

Place the grounding cable with crimping terminal and toothed washer as shown below and tighten the screw.

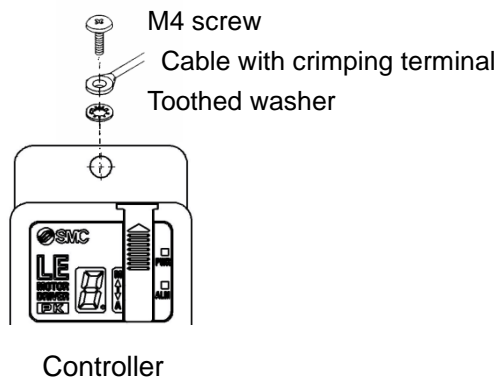

⚠ Caution

The M4 screw, cable with crimping terminal, and toothed washer should be obtained separately.

Ground the controller to shield it from electric noise.

Controller attaching hole (Installation position of grounding cable) and SG (Signal ground) are connected in the controller.

Please do not ground the controller when using it in the plus earth environment.

⚠ Caution

The earthing should be the dedicated grounding point. It should be a functional ground with less than 100 Ω resistance.

The cross section of the grounding wire should be greater than 2mm².

The ground point should be near this controller to make the wire length short.

The controller case mounting is connected to 0 V of the power supply.

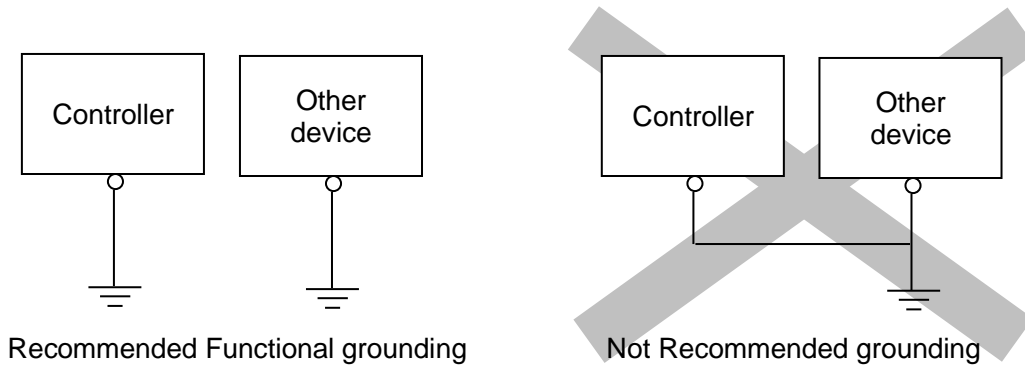

(3) Installation location

Select the size and the installation style so that the ambient temperature around the controller is 40 °C or less.

Mount the controller vertically on a wall with the space allowed as shown in Fig.1.

As shown in Fig.2, establish the construction so that the connectors can be connected and disconnected.

Enough space must be allowed around the controller so that the operating temperature of the controller stays within the specification range.

Avoid mounting the controller near a vibration source, such as a large electromagnetic contactor or circuit fuse breaker on the same panel.

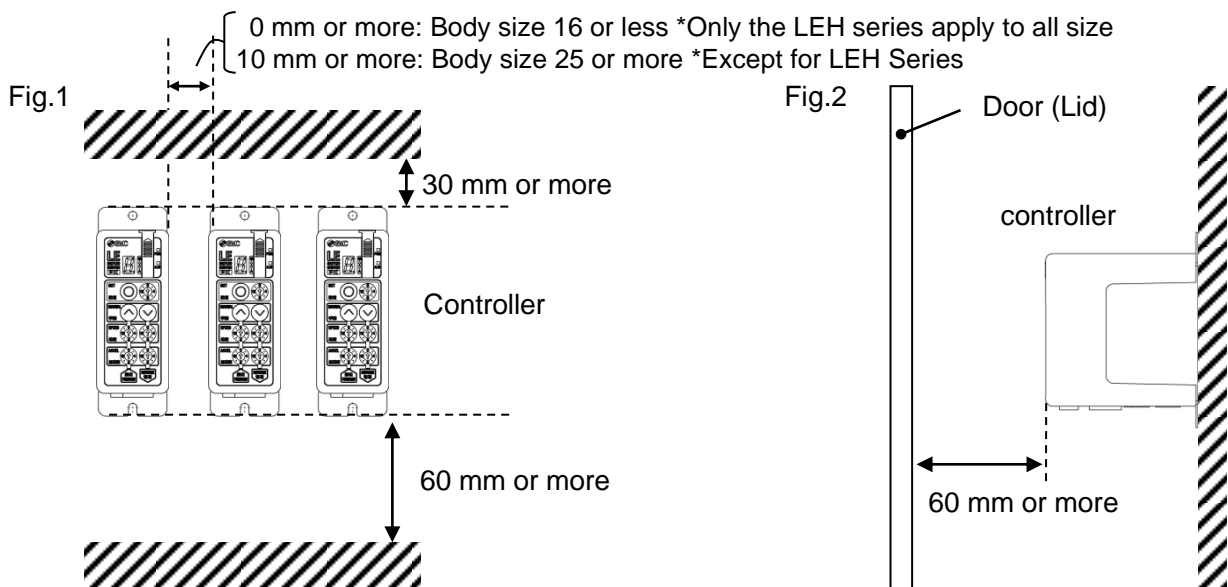

⚠ Caution

If the mounting surface of the controller is distorted or not flat, excessive force may be applied to the housing, etc. causing malfunction.

Mount this product on a plane flat surface.

4. External Wiring Diagram

Examples of standard wiring are shown for each connector (CN1 to CN4) of the controller.

4.1 CN1: Power supply cable

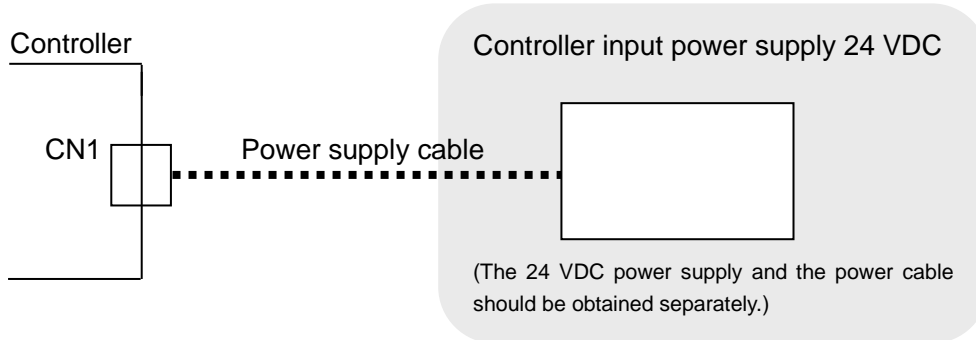

Please refer to "5. CN1: Power supply cable" for how to wire the CN1 connector.

Caution

Do not use the inrush current suppression type power supply for the controller power (24VDC).

4.2 CN2: Motor power connector and CN3: Encoder connector

Connect the controller and the electric actuator with the actuator cable (LE-CP-□-□).

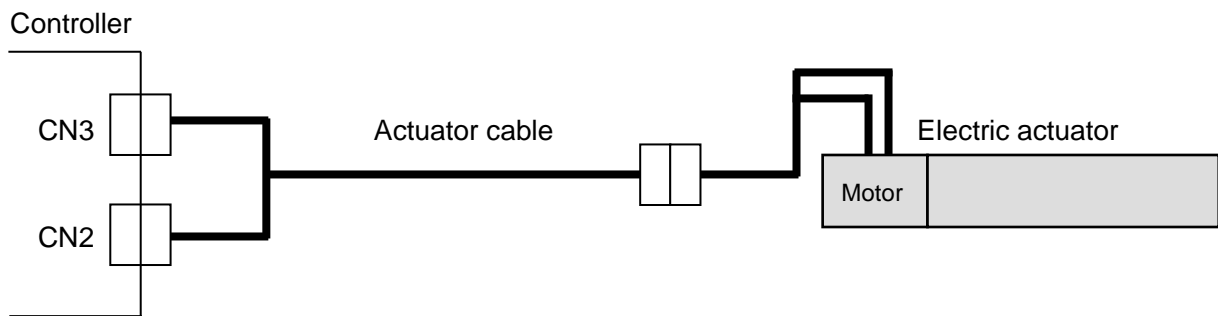

4.3 CN4: Parallel I/O connector

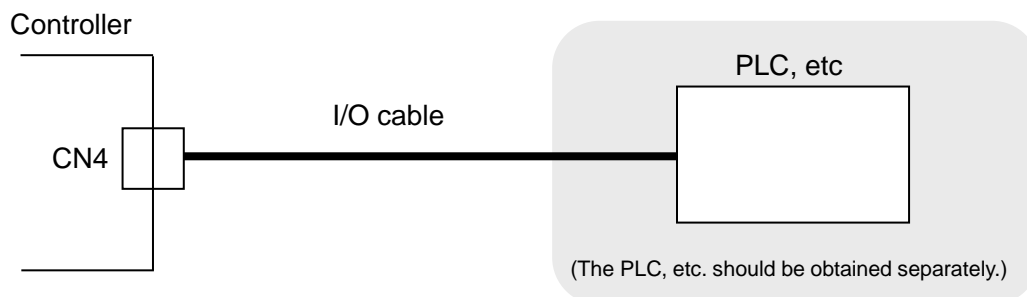

Please refer to "6.4 Parallel I/O Wiring Example" for how to wire the CN4 connector.

Please refer to "6.3 The parallel I/O signal is detailed" for details of each signal of parallel I/O.

5. CN1: Power supply cable

5.1 Power supply cable specifications

Included power supply cable specification is shown below.

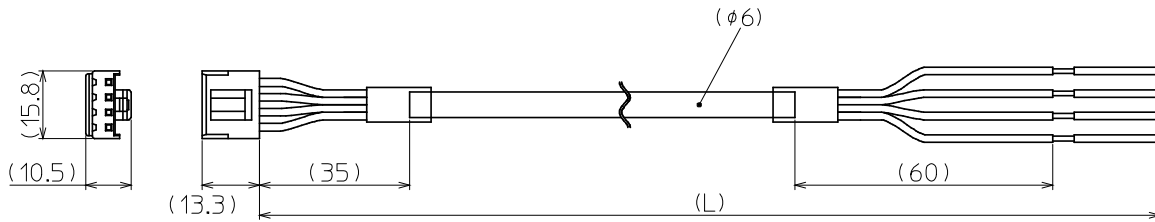

Item	Specifications
Connector	Manufacturer : J.S.T. Mfg. Co.,Ltd. Product number : VHR-4N
Conductor size	AWG20
Length (L)	LEC-CK1-1:1.5m only

Terminal	Color of covered wire	Function	Functional explanation
0V	Blue	Common power supply (-)	Negative common power for M24V, C24V, and BK RLS.
M24V	White	Power supply of motor (+)	Positive power for the motor to be supplied via the controller.
C24V	Brown	Control power supply (+)	Positive control power to be supplied to the controller.
BK RLS	Black	Unlocking (+)	Positive power for lock release. (Connected to the M24V in the controller internal circuit.)

5.2 Wiring of power supply cable

Referring to (1) to (4), connect the power supply cable included in accessories to the controller input power supply 24 VDC and insert it to the controller CN1 power supply connector.

(1) Wiring of the power supply

Connect the positive side (+) of the controller input power supply 24 VDC to the C24V and M24V terminals of the power supply cable, and connect the negative side (-) to the 0V terminal.

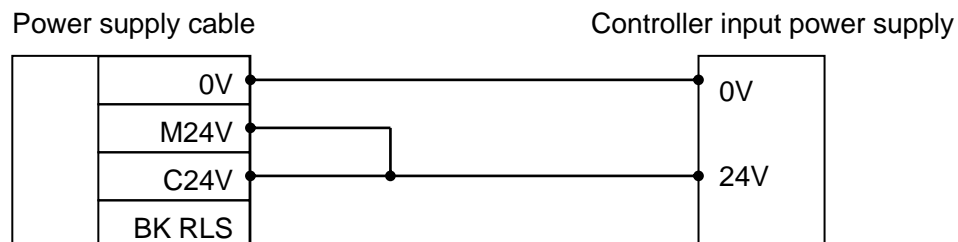

Caution

Do not use the inrush current suppression type power supply for the controller power (24VDC).

(2) Wiring of the lock release

Install an unlocking switch for adjustment or recovery during an emergency of the electric actuator with lock. The switch (24 VDC, Contact capacity: 0.5A or more) should be obtained separately.

One terminal of the lock release switch should be connected to the 24 VDC power supply and the other should be connected to the BK RLS terminal. When this is switched on, the lock will be released forcibly.

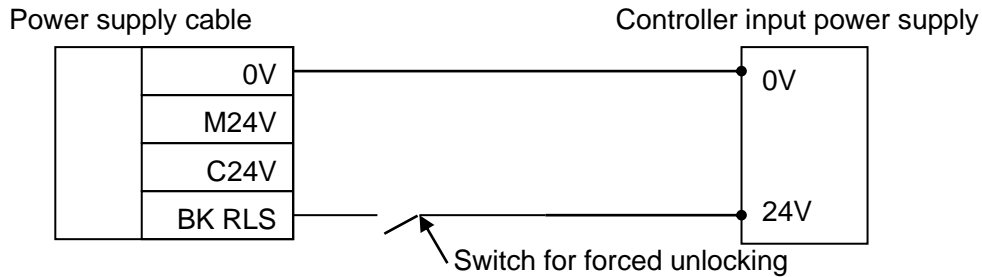

Caution

If the electric actuator is a non-lock type, it is not necessary to wire the BK RLS terminal.
Do not supply power to the BK RLS (lock release) during normal operation.
The 24 VDC supply to the BK RLS (lock release) is only required for the adjustment and the recovery in the emergency.

- STOP command (CN4 14pin STOP) is turned ON and Servo is turned OFF.
- When the control power supply (C24V) is shut off.

(3) Stop the power supply for the motor

If it is necessary to shut off the power supply for the motor from outside, connect the relay between the input power supply for the controller 24 VDC and the power supply plug for the controller M24V.
(Refer to the wiring diagram in the next page.)

The motor power supply should be shut off after the STOP command (CN4 14pin STOP) is turned ON.
Refer to “6.3 Details of parallel input / output signal and cable” for the STOP command

Warning

- Do not perform a return to origin position when the the power supply for the motor (M24V) is off. The controller cannot recognize the correct origin if a return to origin instruction is made with the motor drive power (M24V) disconnected.
- If the M24V is off during electric actuator operation, there will be an additional delay experienced before it stops (the stop distance will be extended) due to inertia of the work piece or regenerated energy. When the M24V is turned off, and the STOP command is turned ON (CN4 14pin STOP) simultaneously the time to stop can be shortened.
- If the motor drive power is off during a vertical stop, the table may drop due to lock response.
- BK RLS is internally connected to the M24V inside the controller, so do not apply 24 VDC to the BK RLS terminal when the M24V is off.

(Circuit example: The figure below shows the stopped state.)

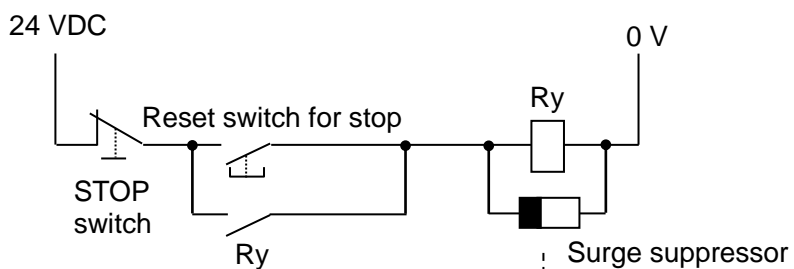

Power supply cable(the 1st controller) Controller input power supply

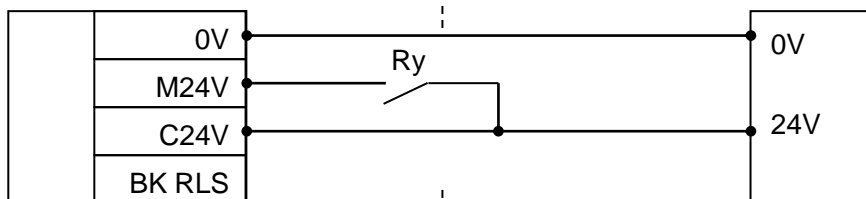

Power supply cable(the 2nd controller) Controller input power supply

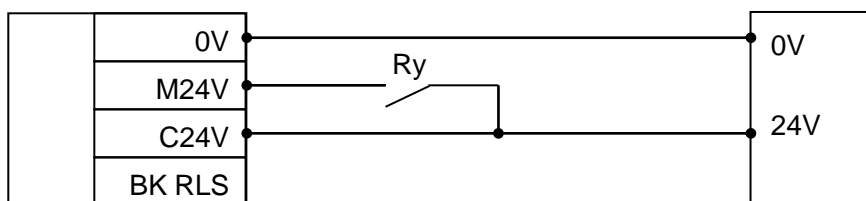

Power supply cable(the 3rd controller) Controller input power supply

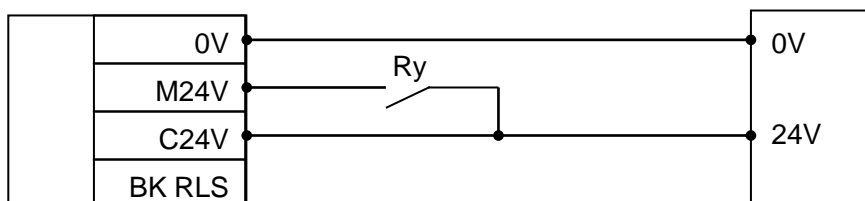

6. CN4: Parallel I/O Connector

6.1 Parallel I/O specifications

Input specifications

No	Item	Specification
1	Input circuit	Internal circuit and photo coupler isolation
2	Number of inputs	6 inputs
3	Voltage	24 VDC +/- 10%
4	Input current at ON	3.5mA +/- 20% (at 24 VDC)
5	Input current / voltage at OFF	Current 1.5 mA or less Voltage 11V or less

Output specifications

No	Item	Specification
1	Output circuit	Internal circuit and photo coupler Isolation
2	Number of outputs	6 outputs
3	Max. voltage between terminal	30 VDC
4	Max. output current	10mA supply / sink
5	Saturation voltage	2.0V (Max.)

6.2 Parallel I/O type (NPN / PNP type)

There are two types of parallel I/O for this controller: NPN type and PNP type.

(1) Parallel I/O input circuit (same for both NPN and PNP type)

● NPN type (LECP2N□□-□)

(a)	「COM+」〈1〉
(b)	IN0〈9〉 to STOP〈14〉

● PNP type (LECP2P□□-□)

(a)	「COM-」〈2〉
(b)	IN0〈9〉 to STOP〈14〉

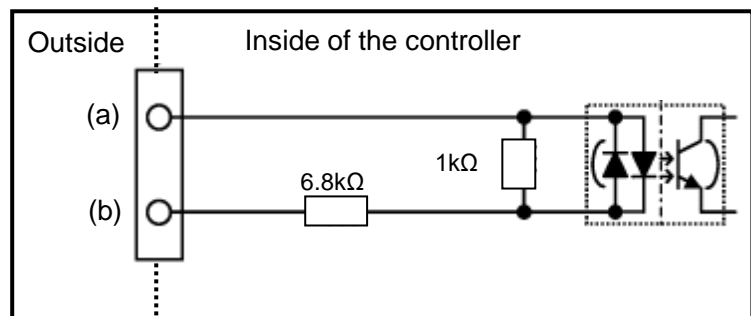

(2) Parallel I/O output circuit

● NPN type (LECP2N□□-□)

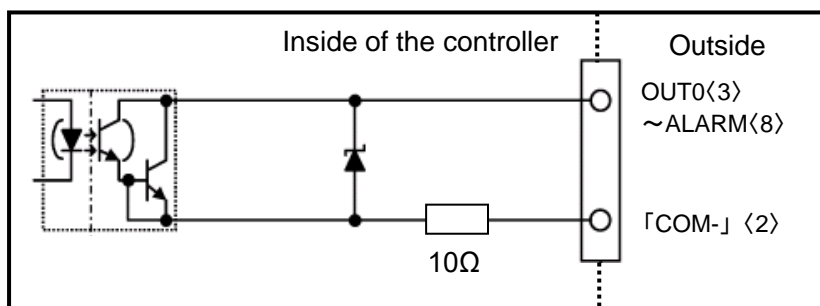

● PNP type (LECP2P□□-□)

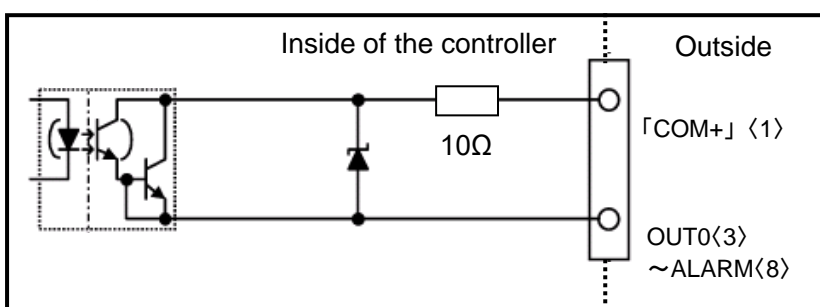

6.3 Details of parallel input / output signal and cable

(1) Parallel I/O cable(LEC-CK4-□)

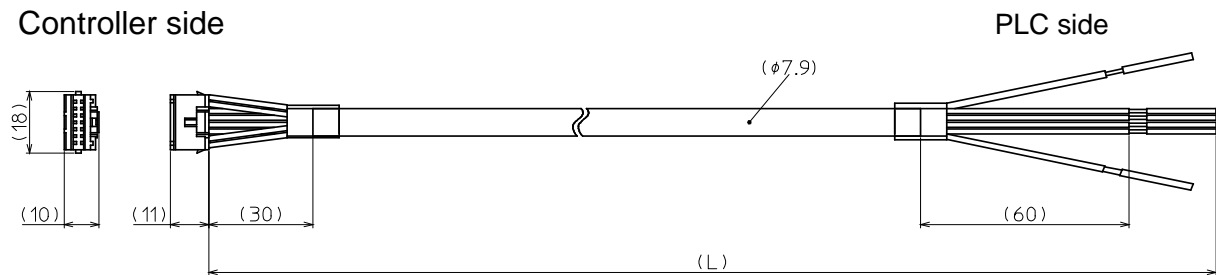

Item	Specification
Connector	Manufacturer : J.S.T. Mfg.Co.,Ltd. Product number : PADP-14V-1-S
Conductor size	AWG26
Length (L)	The suffix of the part number (1,3,5) specifies the length. LEC-CK4-1: 1.5m LEC-CK4-3: 3m LEC-CK4-5: 5m

(2) Details of input / Output signal

Terminal No.	Insulation color	Dot Mark	Dot color	Function	Contents								
1	Light brown	■	Black	COM+	Connect the 24 V side of the power supply (24 VDC) for input / output signal.								
2	Light brown	■	Red	COM-	Connect the 0 V side of the power supply (24 VDC) for input / output signal.								
3	Yellow	■	Black	OUT0	Operation completion output (Output with the combination of OUT0 to OUT3) ^{*1)} •When the return to origin is performed: OUT0 output is turned on only when the return to origin is commanded by IN0. OUT1 output is turned on only when the return to origin is commanded by IN1. •Command the target position (end side or motor end): OUT output equal to the IN input is turned on at the position several mm away from the end. •Target position is intermediate position of the stroke: After stopping at the target position, OUT output equal to the IN input is turned on. Example) Output the operation completion of position No. 3 <table border="1" style="margin-left: 20px;"> <tr> <td>OUT3</td> <td>OUT2</td> <td>OUT1</td> <td>OUT0</td> </tr> <tr> <td>OFF</td> <td>OFF</td> <td>ON</td> <td>ON</td> </tr> </table>	OUT3	OUT2	OUT1	OUT0	OFF	OFF	ON	ON
OUT3	OUT2	OUT1	OUT0										
OFF	OFF	ON	ON										
4	Yellow	■	Red	OUT1									
5	Light green	■	Black	OUT2	After the external stopper of the electric actuator is adjusted, when the operation to motor side or end side is commanded without the stroke study, the electric actuator might not be reached to the stroke ends. In that case, the OUT output state is kept, and the alarm is not generated. Perform the stroke study and register all of the intermediate positions after adjusting the external stopper.								
6	Light green	■	Red	OUT3									
7	Grey	■	Black	BUSY	BUSY signal (Turning ON during operating)								

8	Grey	■	Red	ALARM	ALARM signal N.C. (Turned off when an alarm is generated or servo is turned off. The ALARM output is turned off when STOP is input and the electric actuator has stopped).								
9	White	■	Black	IN0	<ul style="list-style-type: none"> Inputting the intermediate target position command (Input the binary position number by combining IN0 to IN3. *1)) Example) Command to move to position number 5. <table border="1" style="margin-left: 20px;"> <tr> <td>IN3</td> <td>IN2</td> <td>IN1</td> <td>IN0</td> </tr> <tr> <td>OFF</td> <td>ON</td> <td>OFF</td> <td>ON</td> </tr> </table> <ul style="list-style-type: none"> End start command input (only IN0 is ON) Motor start command input (only IN1 is ON) <p>Return to origin When power is applied to the LECP2 in which stroke study has already been performed, the electric actuator return to origin in the specified direction at low speed by turning on the target position command (motor end or end side).</p> <p>When the power is applied to the LECP2 in which stroke study is performed, the input of target position command (IN0, IN1) is disabled.</p>	IN3	IN2	IN1	IN0	OFF	ON	OFF	ON
IN3	IN2	IN1	IN0										
OFF	ON	OFF	ON										
10	White	■	Red	IN1									
11	Light brown	■	Black	IN2									
12	Light brown	■	Red	IN3									
13	Yellow	■	Black	RESET	Operation interruption or alarm reset In action: The speed is reduced from the point where the signal is input until the electric actuator stops. (Servo stays ON) Alarm occurring: Alarm reset								
14	Yellow	■	Red	STOP	Stop command (Immediate deceleration to turn off servo)								

Parallel I/O signal is valid in auto mode. (STOP signal is valid in auto mode and manual mode.)

During manual mode, input signals except STOP is invalid. All output signals are OFF.

During manual mode testing, output signals are valid (input signals other than STOP are invalid)

*1) The following table shows the relation of the position number and the combination of IN0 to IN3 or OUT0 to OUT3.

○: OFF ●: ON

Position number	IN3	IN2	IN1	IN0
1 (End side)	○	○	○	●
2 (Motor side)	○	○	●	○
3	○	○	●	●
4	○	●	○	○
5	○	●	○	●
6	○	●	●	○
7	○	●	●	●
8	●	○	○	○
9	●	○	○	●
10 (A)	●	○	●	○
11 (b)	●	○	●	●
12 (c)	●	●	○	○
13 (d)	●	●	○	●
14 (E)	●	●	●	○

○: OFF ●: ON

Position number	OUT3	OUT2	OUT1	OUT0
1 (End side)	○	○	○	●
2 (Motor side)	○	○	●	○
3	○	○	●	●
4	○	●	○	○
5	○	●	○	●
6	○	●	●	○
7	○	●	●	●
8	●	○	○	○
9	●	○	○	●
10 (A)	●	○	●	○
11 (b)	●	○	●	●
12 (c)	●	●	○	○
13 (d)	●	●	○	●
14 (E)	●	●	●	○

(3) The change of I/O output signal

The change of I/O output signal under the condition of controller at auto mode.

Condition of the controller	Output signal					
	OUT0	OUT1	OUT2	OUT3	BUSY	ALARM
Right after supplying power	OFF	OFF	OFF	OFF	OFF	OFF
After supplying power and at the stop before return to origin.	OFF	OFF	OFF	OFF	OFF	ON
During the return to origin, positioning, and pushing operation.	OFF	OFF	OFF	OFF	ON	ON
When return to origin is completed.	*1)	*1)	OFF	OFF	OFF	ON
When positioning operation or pushing operation is completed.	*2)	*2)	*2)	*2)	OFF	ON
Stopped by RESET command	OFF	OFF	OFF	OFF	OFF	ON
Stopped by STOP command	*3)	*3)	*3)	*3)	OFF	OFF
When alarm is generated	OFF	*4)	*4)	*4)	OFF	OFF

*1) Return to origin command is given by the IN0 ON: OUT0 is ON, OUT1-OUT3 are OFF.

Return to origin command is given by the IN1 ON: OUT1 is ON, OUT0 and OUT2,OUT3 are OFF.

*2) The ON / OFF status of OUT0 to OUT3 is different depending on the commanded position number.

*3) Not fixed. Varies depending on conditions. (When STOP command is given, OUT0 to OUT3 are OFF. When an alarm is generated, the alarm group is output to the OUT1 to OUT3.)

*4) ON, OFF of OUT1 to OUT3 depends on the alarm group.

There is no servo ON signal with this controller. The servo turns off when conditions to turn off the servo are satisfied. Refer to “8.4 Servo ON” for details.

Caution

- IN0 to IN3 input during the switching from manual mode to auto mode are invalid. IN0 to IN3 become valid after the auto mode is set up.
- Output signal are not output from parallel I/O right after switching from manual mode to auto mode. Output signal will be output from parallel I/O after inputting the next command.
- Output from I/O is not made if switching from auto mode to manual mode.

6.4 Parallel I/O Wiring Example

When you connect a PLC, etc. to the CN4 parallel I/O connector, please use the I/O cable (LEC-CK4-□).

The wiring should be changed depending on the type of the parallel I/O (NPN or PNP).

Please wire referring to the following diagram.

• NPN type

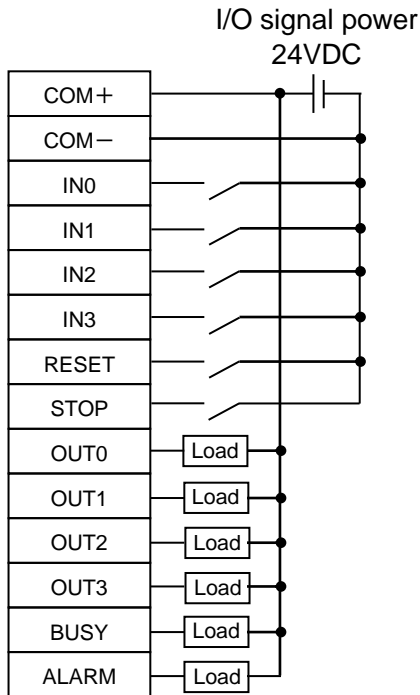

• PNP type

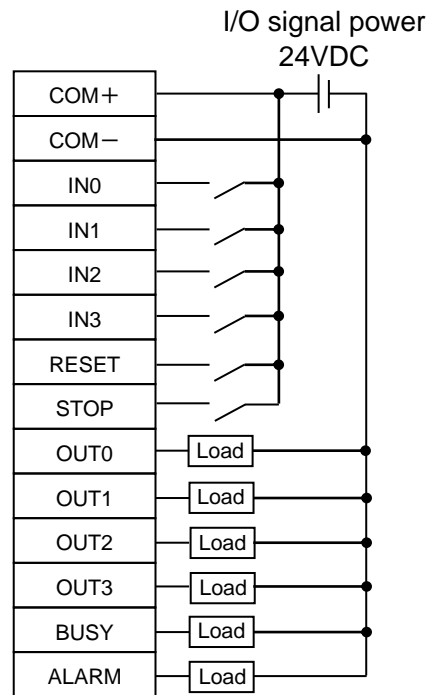

Caution

The 24 VDC controller power supply for CN1 and the 24 VDC I/O power supply for CN4 should be separated.

7. Setting method

It is necessary to set the stop position and operation method using the controller in order to move the electric actuator to the specified position. Set data is stored in the memory in the controller.

In manual mode, operation of the electric actuator is based on position registration parameters. In auto mode, the electric actuator operation is based on setting of external equipment via CN4 parallel I/O.

1. Switching the mode

The mode is switched by moving Mode switch (e).

Upper part of the right figure (M) : Manual mode

Lower part of the right figure (A) : Auto mode

The display at auto mode:

"-" or the position number that is commanded through IN0 to IN3 of CN4 parallel I/O is displayed in 7-segment LED(f).

- When driving : Displayed in flashing state.
- When driving is completed: Displayed in on state.

When the button is pressed or rotary switch is rotated during auto mode, the 7-segment LED(f) flashes for a specified period of time to indicate that inputting by the button or rotary switch is disabled (locked).

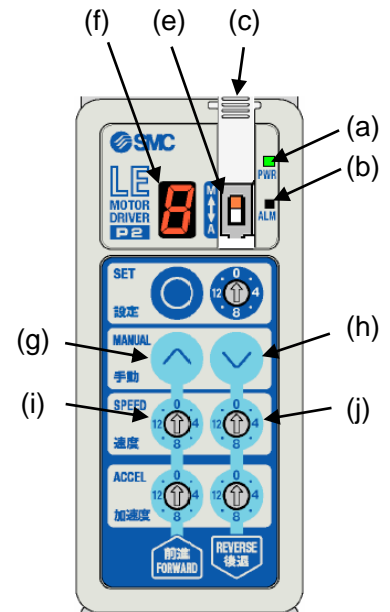

Caution

Close the cover (c) after the switching of the mode to avoid unexpected mode changes.

2. Difference according to mode

○: available ×: not available △: Depending on conditions

	Manual mode (M)	Auto mode (A)
Register intermediate position (Step data registration)	○	×
Stroke study	○	×
Setting of Speed and Acceleration	○	△ (Only in speed adjustment) *1)
Setting of parameters	○	×
Driving the electric actuator with using the button on the controller	○	×
Operation of the electric actuator via CN4 parallel I/O	×	○
Positioning operation (In LECP2 pushing operation is not available)	○	○
Test run	○	×
Check the presence of alarm (Alarm LED(b))	○	○
Check the content of alarm (7-segment LED (f) display)	○	○
How to release the alarm	Press set button (g)	Turn on RESET or press set button (g)
Servo OFF method	Press Forward button (i) and Reverse button (j) simultaneously for 3 sec. - Turn on STOP	Turn on STOP

*1) Refer to “7.2. Setting of the speed and the acceleration” for details of the adjustment of the speed in the auto mode.

7.1 Setting procedure

Follow the procedure below for setting.

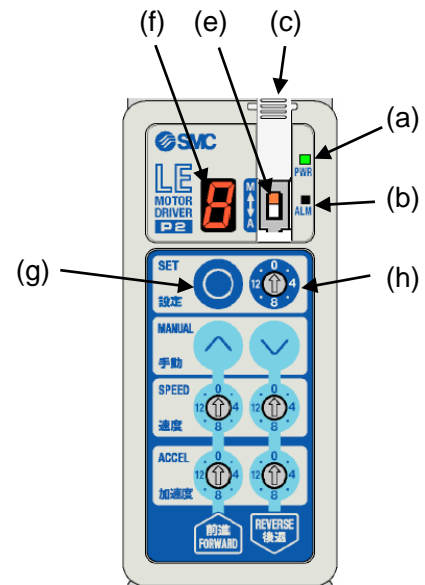
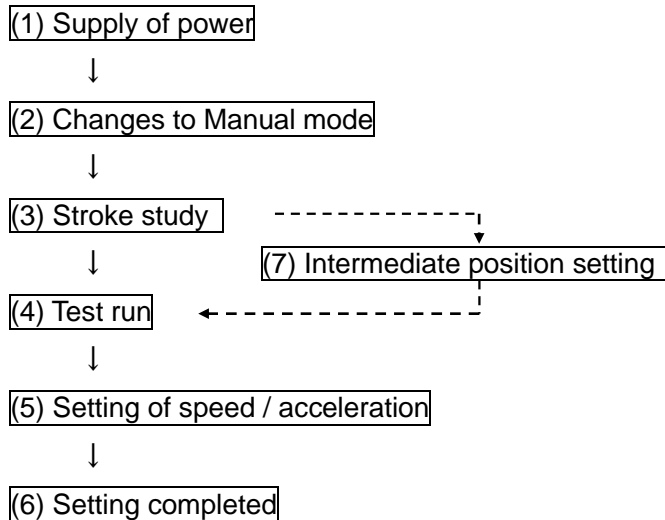

(1) Supply of power

Apply 24 VDC to the power supply for the power line and the signal line. After applying the power, confirm that the Power supply LED (a) lights green (= Servo ON). Refer to “8.4 Servo ON” if the power supply LED (a) flashes green (= Servo OFF).

When alarm LED (b) lights up, refer to “11. Alarm Detection”.

(After supplying power, it may take approximately 10 seconds (max. 20 sec.) until ALARM is output depending on the electric actuator positions.)

(2) Changes to Manual mode

Switch the controller mode switch (e) to manual mode (M side). In manual mode, the 7-segment LED (f) indicates the value of the position switch (h) with high speed flashing.

(3) Stroke study

Electric actuator end and motor end can be automatically detected and registered to the controller. Be sure to perform a "Stroke study" before initial operation and when the operating stroke range is changed, due to the replacement of the electric actuator or the installation of an external stopper.

*When power is supplied to the controller just after it is delivered, LED [ALM] flashes in red. This indicates that stroke study is not yet performed. Please perform Stroke study.

After the external stopper of the electric actuator is adjusted, when operation the operation to motor side or end side is commanded without the stroke study, the electric actuator might not be reached to the stroke ends.

After the external stopper of the electric actuator is adjusted, when the driving to motor side or end side is commanded without the stroke study, the electric actuator might hit the stroke ends or external stopper, and the electric actuator might be broken.

1) Movement of Stroke study

When “Stroke study” is performed, the electric actuator drives to the end side and the motor side, and detect the stroke ends of electric actuator.

The positions of stroke ends are registered in the controller by this operation.

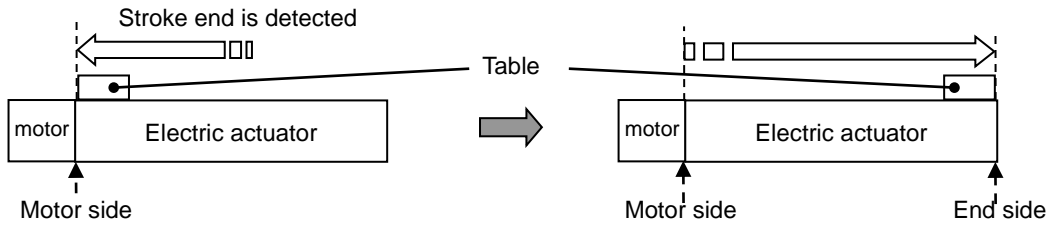

1. Table moves to motor side of electric actuator.

2. Table drives to end side of electric actuator.

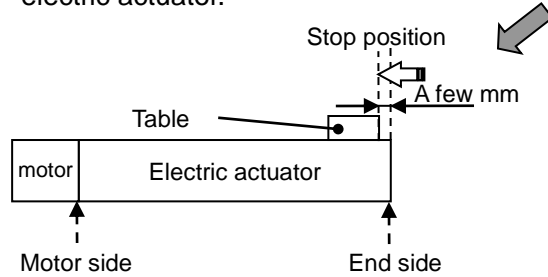

3. Table drives a few mm to motor side and stops. (Completed)

Caution

When the parameter “Reference for rotating direction” is changed, the driving direction in “Stroke study” is opposite to above explanation.

2) Procedure of Stroke study

1. Switch to manual mode (M side) by Mode switch (e).
2. Rotate Position switch (h) to “15”.
LED(f) displays “F” with flashing.
3. Push Set button (g) and keeps pushing 3 seconds or more.
Stroke study is started.
4. When the display "F" in LED (f) is changed from flashing state to solid light state, Stroke study is completed.

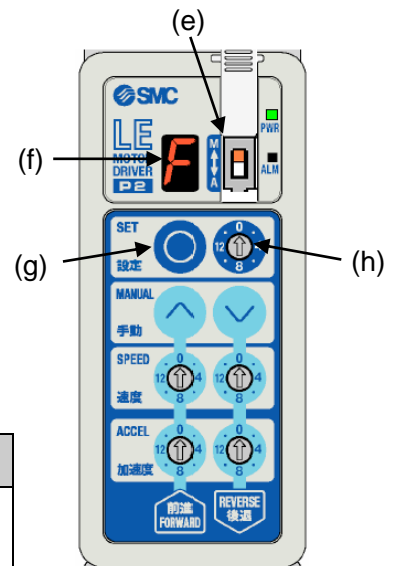

Caution

During stroke study, all registered intermediate positions are changed.
Register all intermediate positions (position number from 3 to 14(E)) again.

(4) Test run

Check the registered positions by operating the electric actuator with the controller button and switch operation. The test operation procedure is as follows.

- 1) Rotate the position switch (h) to the position number to be tested.
- 2) Confirm that the 7-segment LED (f) flashes at the specified position number.
- 3) Press the set button (g).

When the display in LED (f) is changed from flashing state to no-flashing state, Trial run is completed.

Item	Test operation state
Input of CN4 parallel I/O	Disable (Valid only for STOP)
Output of CN4 parallel I/O	The output state when switching to manual mode is kept
The display of 7-segment LED	Before Test run : The position number flashes During Test run : “-” flashes. Reaching the target position : Position number lit
Adjusting speed and acceleration	Possible by using (k) to (n)

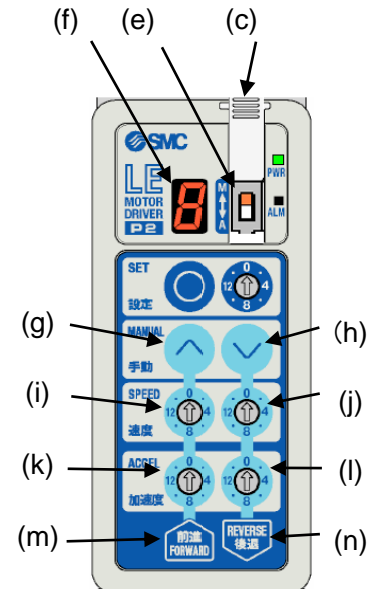

(5) Setting of Speed and Acceleration

One speed and acceleration can be set for each movement direction (Reverse and Forward) and it is applied for the operation of all position numbers.

Set the speed and the acceleration by switch (k) to (n) per direction of actuation. The switch can be set in 16 steps. Actual value depends on the electric actuator. Refer to “**10. Initial setting value of electric actuator (LEM series)**” for details of setting the speed and the acceleration. The operation with the set speed and acceleration can be checked by test run as shown above (4) Test run.

Different speeds and accelerations cannot be individually set for positioning of each position number.

(6) Completion of setting

After set-up is completed, switch to auto mode using the mode switch (e) and perform operation with PLC. Please confirm “**9. Operation instruction**” for driving instruction method with PLC.

! Caution

Close the cover (c) after the switching of the mode to avoid unexpected mode change.

(7) Intermediate position setting

In the manual mode after return to origin, the position can be registered by the following 2 methods.

(A) Position setting by Jog operation and Inching operation.

Method to register the electric actuator slider position by Jog or Inching operation.

The following is an example of registering a position in position number 3.

- 1) Switch Position switch (h) to the position number to register ("3" is in this example).
7-segment LED (f) displays the position number.

The position can not be registered into the position number "0", "1", "2" and "F (15)".

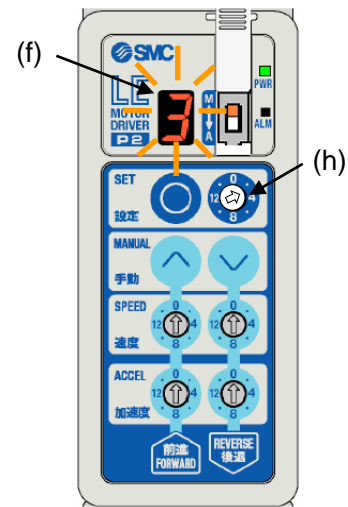

- 2) When PWR LED (a) is ON, push Set button (g).
The electric actuator drives to the originally registered position in the commanded position number.
When completing, the display of 7-segment LED (f) change from flashing state to solid light state.
Then, keep pushing Set button (g) until 7-segment LED (f) displays with flashing.

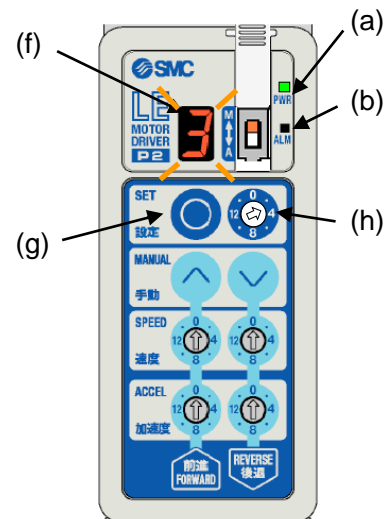

The electric actuator stops on the way when Set button (g) is pushed during driving the electric actuator.

Then, when Set button (g) is pushed again, the electric actuator drives to the originally registered position.

Caution

- When procedure **(2) Changes to Manual mode** is performed before the return to origin is not completed, the driving command is canceled and the electric actuator does not drive. In that case, perform the return to origin.
- When the electric actuator cannot drive to the originally registered position due to the

- 3) Move to the position to be registered with the Jog or Inching operation using the Forward button (i) or Reverse button (j).

Inching starts by pressing either the Forward button (i) or Reverse button (j).

Jog starts by holding down either the Forward button (i) or Reverse button (j).

For further details, refer to "8.3 Jog operation / inching operation".

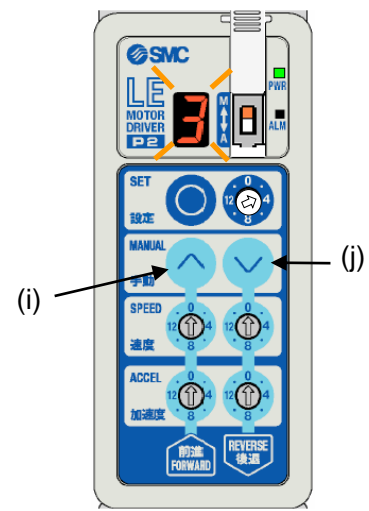

- 4) Keep pressing the set button (g) from solid light state of the 7-segment LED (f) until it stays on to indicate registration of the position.

When the position is registered and set button (g) is released, 7-segment LED (f) returns to the flashing state.

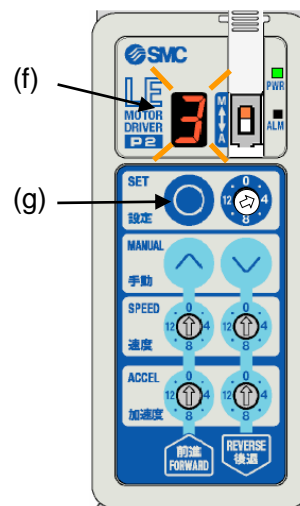

Registering the position by jog operation / inching operation is completed.

Caution

If you perform jog / inching operation before the servo is turned on (Power supply LED (a) lights up in green), an alarm is generated. Perform jog / inching operation after confirming that the servo is turned on.

(B) Setting by direct teaching (Ex. Position switch initial value [4])

Method to register the electric actuator slider position by moving the slider by hand.

The method below is an example of how to register the position to position number 3.

- 1) Press the Forward button (i) and Reverse button (j) simultaneously for 3 seconds or longer until the flashing state of 7-segment LED changes to the on state. When the 7-segment LED state has changed, the power supply LED state changes from on to flashing.

The power supply LED (a) flashing indicates that the servo is off.

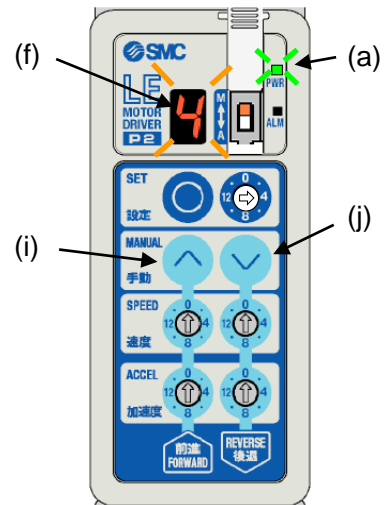

- 2) Rotate the position switch (h) to the required position ("3" in this case).

The position number specified by the position switch (h) is lit on the 7-segment LED (f).

"1" and "2" are the position number for the stroke ends. They cannot be registered for intermediate position.
"0" and "F(15)" are not position numbers. They cannot be registered for intermediate position.

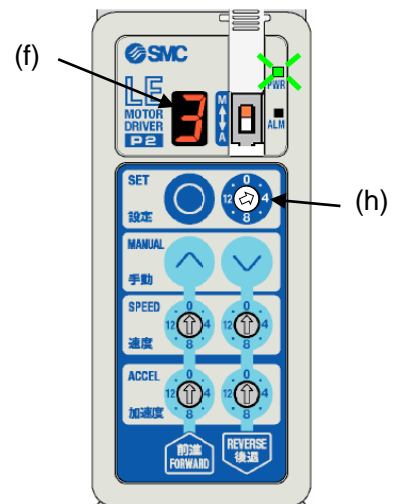

- 3) Keep pressing until the 7-segment LED (f) is flashing.

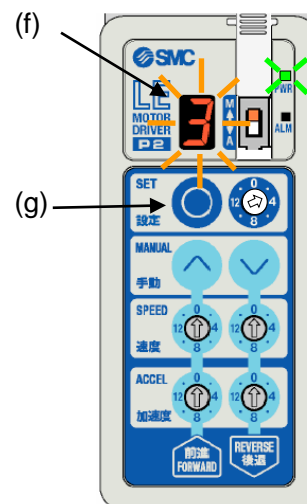

- 4) Move the electric actuator slider to the position to register slowly using external force.
- 5) Keep pressing the set button (g) from the flashing state of the 7-segment LED (f) until it remains on, for registration of the position.

If you perform procedure **(4) Test run** before performing return to origin, an alarm is generated (7-segment LED (f) displays [A] and alarm LED (b) will turn on). In this case, press the set button (g) to release the alarm. Then perform return to origin

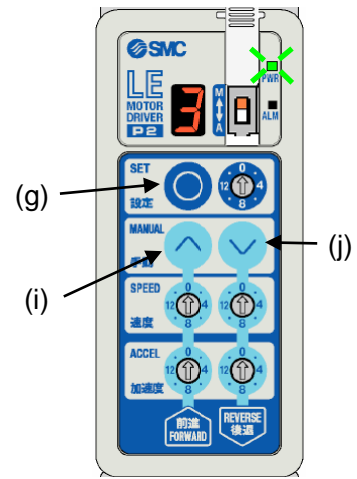

- 6) Press the Forward button (i) and Reverse button (j) simultaneously until the power supply LED (a) changes from flashing to the on state. Returns to servo ON state.

Positioning by direct teaching is complete.

Caution

The slider of the electric actuators with a smaller lead may not be moved by the external force. Perform (A) Position setting by Jog operation and Inching operation on the previous page.

7.2 Setting of the speed and the acceleration

The speed and the acceleration can be set by using switch (k) to (n) in each driving direction.

This setting of the speed and the acceleration applies to the driving of all position number.

The speed and the acceleration cannot be set in each position number respectively.

● How to set the speed and the acceleration

According to the mode, the setting procedure of the speed and the acceleration is different. And the application of the function of changed setting is different.

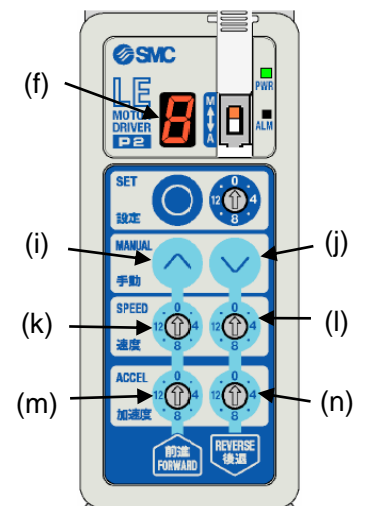

The difference in the setting of the speed and the acceleration according to the mode is shown in the table below.

Setting of the Speed and the Acceleration	Manual mode(M)	Auto mode(A)
Method	Change the switch (k) to (n)	1) Keep pushing Forward button (i) and Reverse button (j) for 3 seconds or more. 2) Rotate the switch(k) to (n) while “□”(value (or “-.”)) is lit in the 7-segment LED (f).
When changeable Controller state	Always (It is required that the stroke study has been completed.)	State in which “□.”(value (or “-.”)) is lit in the 7-segment LED (f).
Setting value	16 steps of speed and acceleration can be set. The set value of the speed and the acceleration are different according to the electric actuator. Refer to “10. Initial setting value of electric actuator (LEM series)”.	
Change speed, acceleration reflection timing	Applied when the electric actuator is stopping. Not applied when the electric actuator is driving. Applied after the electric actuator stops.	
Change speed, acceleration applied operation	Test run	Positioning operation by parallel I/O

7.3 Setting parameters

In manual mode, it is possible to set parameters. The 3 parameters below can be set and changed.

Parameters No.	Description of parameters	Value and the content of parameters										
1	Reference for rotating direction	Change the direction of the return to origin and forward and reverse *1) <table border="1"> <thead> <tr> <th>Value</th> <th>Description</th> </tr> </thead> <tbody> <tr> <td>1</td> <td>CW</td> </tr> <tr> <td>2</td> <td>CCW</td> </tr> </tbody> </table>	Value	Description	1	CW	2	CCW				
Value	Description											
1	CW											
2	CCW											
2	Jog speed level	Sets the speed of jog and inching operation. $\text{Jog, inching speed} = (\text{Reference value of electric actuator}) \times (\text{power})$ <table border="1"> <thead> <tr> <th>Value</th> <th>Description</th> </tr> </thead> <tbody> <tr> <td>1</td> <td>1 (Default value at the time of shipment)</td> </tr> <tr> <td>2</td> <td>2</td> </tr> <tr> <td>3</td> <td>4</td> </tr> <tr> <td>4</td> <td>8</td> </tr> </tbody> </table>	Value	Description	1	1 (Default value at the time of shipment)	2	2	3	4	4	8
Value	Description											
1	1 (Default value at the time of shipment)											
2	2											
3	4											
4	8											
3	Inching level	Sets the moving distance during the inching operation. $\text{Inching level} = (\text{Reference value per electric actuator}) \times (\text{Multiplier})$ <table border="1"> <thead> <tr> <th>Value</th> <th>Description</th> </tr> </thead> <tbody> <tr> <td>1</td> <td>1 (Default value at the time of shipment)</td> </tr> <tr> <td>2</td> <td>2</td> </tr> <tr> <td>3</td> <td>4</td> </tr> <tr> <td>4</td> <td>8</td> </tr> </tbody> </table>	Value	Description	1	1 (Default value at the time of shipment)	2	2	3	4	4	8
Value	Description											
1	1 (Default value at the time of shipment)											
2	2											
3	4											
4	8											

*1) The default value varies depending on the electric actuator.

Please refer to the manual of the electric actuator for more details.

The procedure to set the parameters is shown below.

1) Switch the controller mode switch (e) to manual mode (M).

Example: "4" (Default value of position switch)

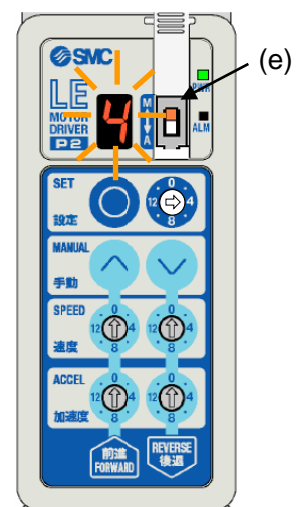

2) Press and hold the Forward button (i) and Reverse button (j) simultaneously for 3 seconds so that the power supply LED (a) is changed from a solid light to a flashing.

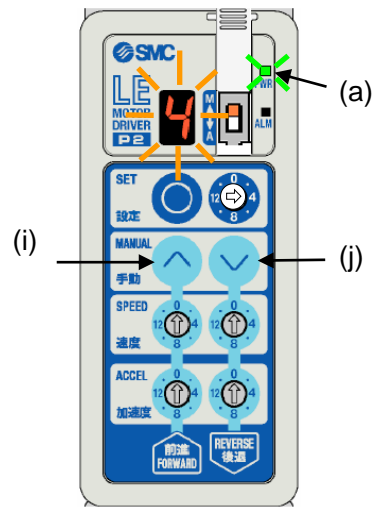

3) Set the value of the position switch (h) to "0" and press and hold the set button (g) for 3 seconds. The 7-segment LED (f) displays "0" with a dot and the alarm LED (b) flashes.

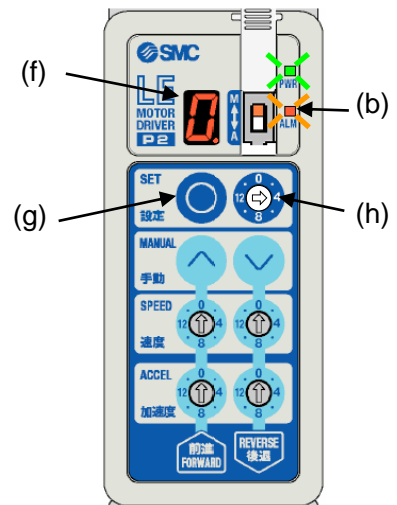

4) When the position switch (h) is set at the required parameter number ("2" in this case), the 7-segment LED (f) displays the value of the position switch (h) with a dot.

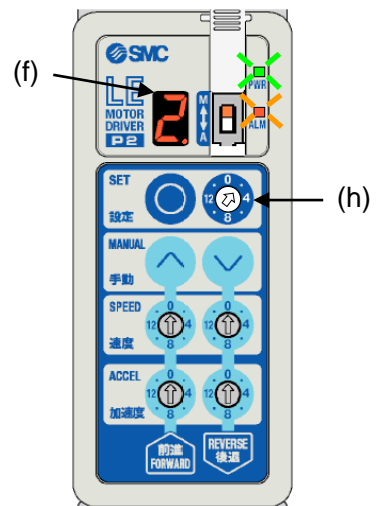

No.	Description	Function
1	Reference for rotating direction	Changing forward and backward direction
2	Jog speed level	Jog operation, speed setting during inching operation
3	Inching level	Setting in moving distance during inching operation

Refer to “7.3 Setting parameters” for the details of parameters.

5) Push set button (g) the 7-segment LED(f) displays the set value of the parameter without a dot.

If the value of the position switch (h) is changed at this stage, it will return to the state of 4) above.

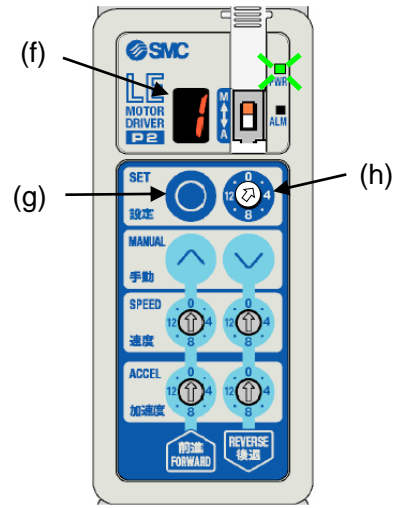

6) Press the set button (g) for 2 seconds or longer to change the 7-segment LED(f) from on to flashing state.

The set parameter value can be changed during this state.

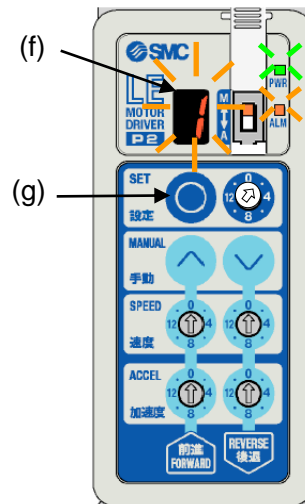

7) Push Forward button (i) or Reverse button (j) to change the set value of the parameter ("3" is in this example).

Keep pushing Set button (g) until the display of 7-segment LED (f) changes from flashing state to on state (for 2 seconds or more). When the display of 7-segment LED (f) is no-flashing state, the set value is registered into the controller.

The changed parameter is applied after the power supply for the controller is re-supplied.

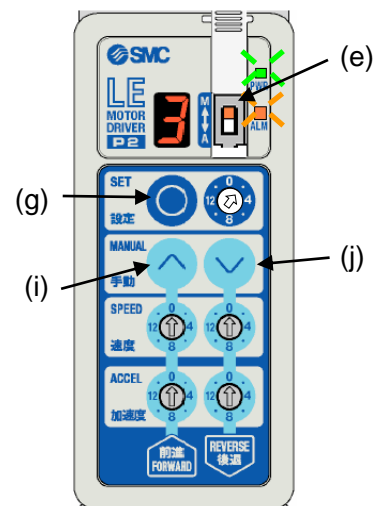

The parameter setting is completed.

When set the other parameter, repeat the procedure of 4) to 7).

⚠ Caution

- The changed parameter is applied after the power supply for the controller is re-supplied.
- For the default value of the return to origin and the reference value of jog speed and inching amount, refer to “10. Initial setting value of electric actuator (LEM series)”.
- When the reference for rotating direction is changed, the direction of forward and reverse is switched, and the speed and acceleration per direction are changed as well. Therefore, it is necessary to set the position, speed and acceleration again.

8. Operations

8.1 Return to origin

Origin return is necessary after turning on the power supply in this controller.

By recognizing the stroke end by return to the origin, positioning operation of the electric actuator becomes possible.

(1) Return to origin operation

When power is supplied to the controller, the first command to move toward the stroke end is recognized as the return to origin command.

Controller speed and acceleration setting switches are ignored. The slider of the electric actuator moves toward the specified direction with the speed and acceleration of the electric actuator itself.

After that, the electric actuator keeps pushing the stroke end.

When the electric actuator keeps pushing the stroke end for several seconds, the controller recognizes the current position as the stroke end and the return to origin is completed.

The stop position in all position numbers doesn't change regardless of the direction of the return to origin.

The speed of the return to origin depends on the electric actuator. Refer to “**10. Initial setting value of electric actuator (LEM series)**” for the default setting of the return to origin.

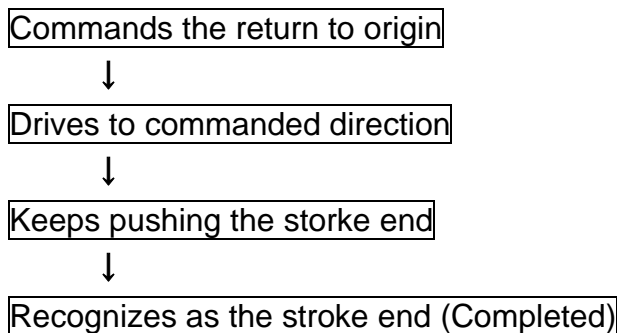

Return to origin commanded to motor side

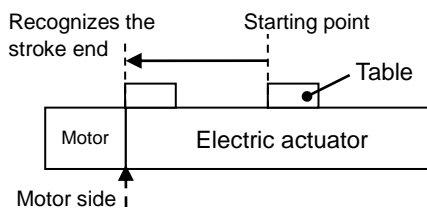

Return to origin commanded to end side

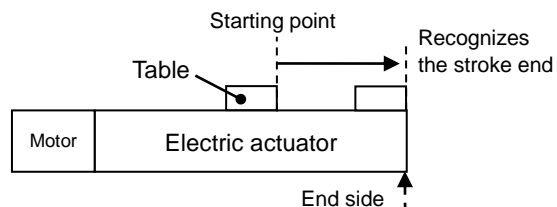

(2) How to command the return to origin

Only when the following two conditions are satisfied, it is possible to command the return to origin.

- Stroke study has been completed before.
- It must be immediately after turning on the controller.

Return to origin command is an operation command to the first stroke end after turning on the power supply.

Return to origin command method includes manual mode and auto mode.

Manual mode:

- 1) Supply the power supply to the controller.
- 2) Switch the position switch (h) to "1" or "2", and push Set button (g).

During return to origin, 7-segment LED (f) displays "F" with flashing.

- Switch the position switch "1": Return to origin by end side movement.
- Switch the position switch "2": Return to origin by motor side movement.

- 3) When the return to origin is completed, the display of 7-segment LED (f) changes from flashing state to solid light state.

Auto mode:

- 1) Supply the power supply to the controller.
- 2) Turn on IN0 or IN1 input in CN4 parallel I/O.

During return to origin, 7-segment LED (f) displays "F" with flashing.

- Turn on IN0: Return to origin by end side movement
- Turn on IN1: Return to origin by motor side movement.

- 3) When the return to origin is completed, OUT0 or OUT1 output turns on.

- When return to origin with IN0 ON: OUT0 output turns on. OUT1 to 3 output turns off
- When return to origin with IN1 ON: OUT1 output turns on. OUT0, OUT2 to 3 output turns off.

When the power supply is supplied to controller, only "Stroke study" and "The command to stroke end (The return to origin)" is valid in the first command to drive.

When an operation toward the intermediation position is commanded immediately after power is supplied, return to origin is invalid.

When a stroke study is performed, return to origin is performed simultaneously. After the stroke study, the command to move toward the stroke end is not recognized as return to origin command.

Positioning operation will be performed.

8.2 Positioning operation

Accelerate to the set speed with the acceleration set for each movement direction

When the set speed is reached, it moves at constant speed.

At the target position, decelerate at the acceleration set for each direction, and stop at the target position.

- Positioning operation instruction method
Positioning operation can be command under the condition that return to origin is completed.
Return to origin instruction method includes manual mode and auto mode.

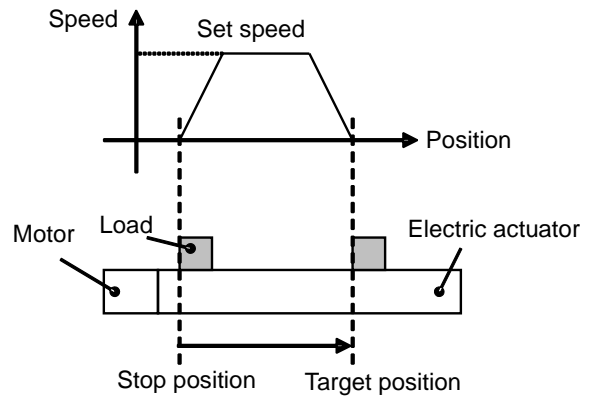

The speed wave in the chart above is simplified

Manual mode:

The positioning operation can be commanded in test run function.

Refer to “**7.1(4) Test run**” for details of how to command the positioning operation in test run function.

Auto mode:

The positioning operation can be commanded through CN4 parallel I/O.

Refer to “**9.2(2) Positioning operation: Driving to the stroke end and Driving to the intermediate position**” for detail of how to command the positioning operation through CN4 parallel I/O.

8.3 Jog operation / inching operation

Jog operation and Inching operation can be operated in manual mode.

(1) Jog operation

The electric actuator moves to the specified direction while the button is pressed. It stops when the button is released. This operation is available before return to origin is performed.

Procedure

- 1) Switch the controller mode switch (e) to manual mode (M).
- 2) When the Forward button (i) and Reverse button (i) are pressed simultaneously, the inching operation starts. When the buttons are pressed for longer than 1 second in that state, Jog operation starts.

When this button is released, the product stops operating.

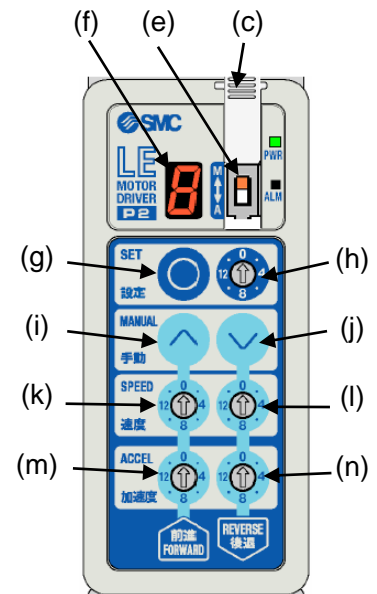

(2) Inching operation

When the button is pressed once, the electric actuator moves for a specified distance in the specified direction and stops. The operation is available before return to origin is performed.

Procedure

- 1) Switch the controller mode switch (e) to manual mode.
- 2) Press the Forward button (i) or Reverse button (j). The electric actuator will perform the inching operation in the specified direction and stops.

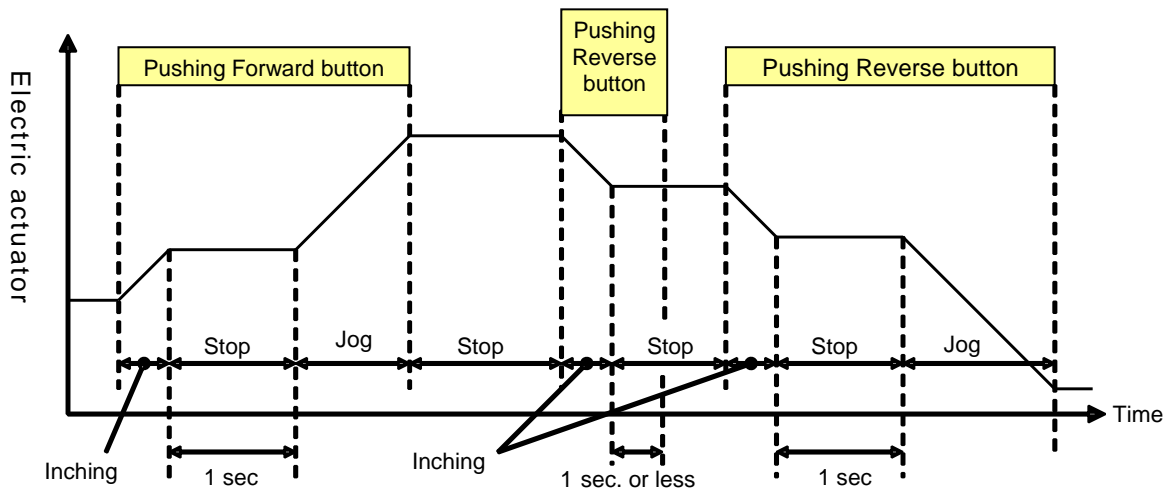

⚠ Caution

- The driven distance and the speed when Inching, and the speed when Jog are different in each electric actuator.
Refer to “10. Initial setting value of electric actuator (LEM series)” for details.
- The driven distance and the speed when Inching, and the speed when Jog can be change by the parameter.
Refer to “7.3 Setting parameters” for details.

8.4 Servo ON

Servo ON signal is not assigned to the parallel I/O of this controller. When the power supply is supplied to controller, "Servo on" is automatically commanded in the controller. At this time, when the alarm is not generated, the electric actuator becomes the servo on state after a few seconds.

(Just after the motor power is applied, it may take up to 10 seconds for ALARM output depending on the electric actuator position.)

When the electric actuator becomes the servo on state normally, Power LED (a) changes from flashing state to no-flashing state.

The table below shows conditions for becoming servo off state.

Mode	Conditions for becoming servo off state.	Indication when servo OFF
Manual mode	1) Alarm generated → <u>Servo ON is recovered</u> when the set button (g) is pressed and the alarm is released. 2) Press the Forward button (i) and Reverse button (j) simultaneously for 3 seconds or longer. <u>Manual Servo OFF</u> →Press the Forward button (i) and Reverse button (j) simultaneously again for 3 seconds or longer. Manual Servo ON	Power LED (a): Flashing
Auto mode	1) Alarm generated → <u>Servo ON is recovered</u> when the RESET input is ON and the alarm is released. 2) When CN4 parallel I/O STOP input signal is ON → <u>Servo ON is recovered</u> when the STOP input signal is OFF.	Power LED (a): Flashing

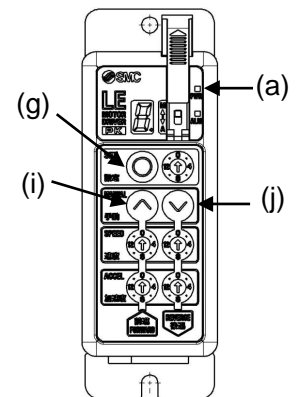

8.5 Response time for the controller input signal

Response delay due to the controller input signal contains following factors.

- (1) Controller input signal scan delay
- (2) Delay due to input signal analysis
- (3) Delay of command analysis

Leave an interval of a minimum of 15 ms (recommendation is 30 ms) between input signals and maintain the state of the signal for a minimum of 15ms (recommendation is 30 ms), because PLC processing delays and controller scanning delays can occur. Time the input signal conditions according to the response output signals.

When one command is made by inputting several I/O simultaneously, the time difference between signals has to be 3 ms or less. If the time difference is longer than 3 ms, it is recognized as another signal and starts the operation. For example, when IN0 and IN1 are commanded to turn ON (position number 3) simultaneously and the time difference between them is large, only the first command is recognized (Only IN0 input is recognized in the following example).

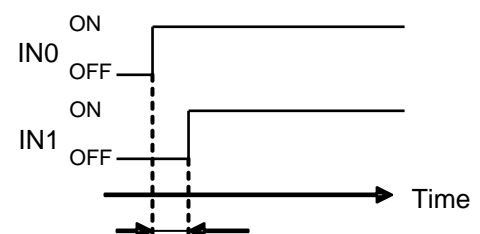

If the time difference is large, only IN0 input is recognized.

9. Operation instruction

9.1 Operation instruction overview

(1) Return to origin

When the power supply is supplied to controller in the state that Stroke study has completed, the return to origin starts in the first turning on of IN0 or IN1. The electric actuator performs the return to origin to commanded direction with the speed and acceleration of the electric actuator or itself

(2) The command to drive to the stroke end and the intermediate position

1) The command to drive to the stroke end:

After registering the stroke end into the position number 1 and 2 in this controller by Stroke study, the electric actuator drives to the registered position in the position number by the set speed and set acceleration when commanding the position number through CN4 parallel I/O.

2) The command to drive to the intermediate position:

After registering the stop position into the position number 3 to 14 in this controller, the electric actuator drives to the registered position in the position number by the set speed and set acceleration when commanding the position number through CN4 parallel I/O.

(3) Stop

1) Reset of driving

During positioning operation, the RESET input turns on to decelerate during operation and maintains the servo ON status and stops.

2) STOP input signal

During positioning operation, when turning on the STOP input signal, the electric actuator decelerates rapidly on the way of driving and stops. Then the electric actuator change to the servo OFF state.

9.2 Operating procedure of parallel I/O

The operation procedure is shown below.

(1) Power on → Return to origin

- Procedure-

1) Apply the power supply.



2) The servo ON instruction (state in which the motor can operate) is automatically done inside the5 controller. When servo turns on normally *ALARM output turns on.

The time to servo on differs depending on the type of electric actuator and conditions of use.

In case of electric actuator with lock, lock is released.



3) Turn on IN0 or IN1 input signal.



4) BUSY output signal turns on.

(The electric actuator starts to drive.)

Controller speed and acceleration speed setting switches are ignored. The electric actuator moves with the speed and acceleration of the electric actuator itself.



5) BUSY output signal turns off. (The electric actuator stops.)

OUT0 output signal turns on when turning on IN0 input signal.

OUT1 output signal turns on when turning on IN1 input signal.



6) Return to origin is completed.

- Timing chart Power on → Return to origin -

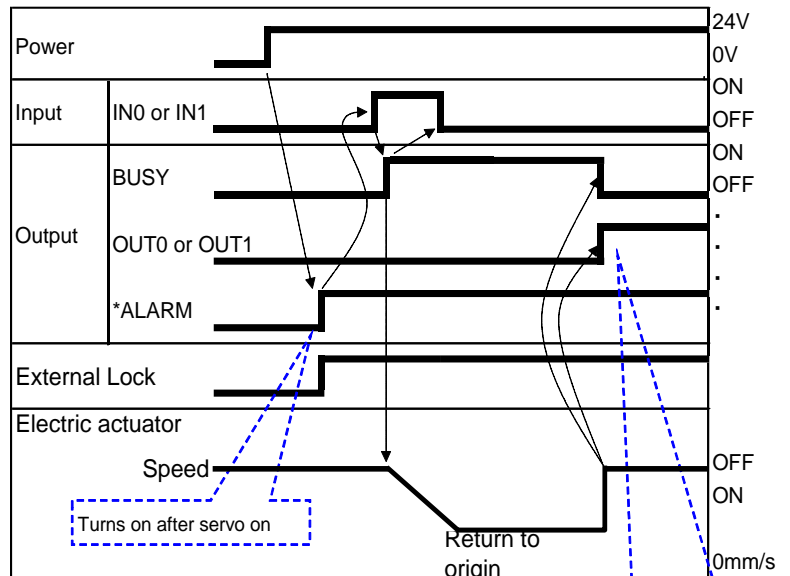

The "*ALARM" is expressed as negative-logic circuit.

OUT0, OUT1, OUT2, OUT3
Output signals are all ON when

(2) Positioning operation : Driving to the stroke end and Driving to the intermediate position

- Procedure - Driving to the stroke end -

- 1) Turn on IN0 (To end side) or IN1 (To motor side) input signal.
- ↓
- 2) OUT turns OFF and BUSY output signal turns on. (Starts to drive to stroke end)
- ↓
- 3) From a few mm of stroke end, OUT0 output signal turns on when turning on IN0 input signal. OUT1 output signal turns on when turning on IN1 input signal.
- ↓
- 4) BUSY output turns off. (The electric actuator stops.)
After OUT0 or OUT1 output turns on, the electric actuator drives to the stroke end and stops. Then, BUSY output turns off.
- ↓
- 5) Driving to the stroke end is completed.

- Timing chart- Driving to the stroke end

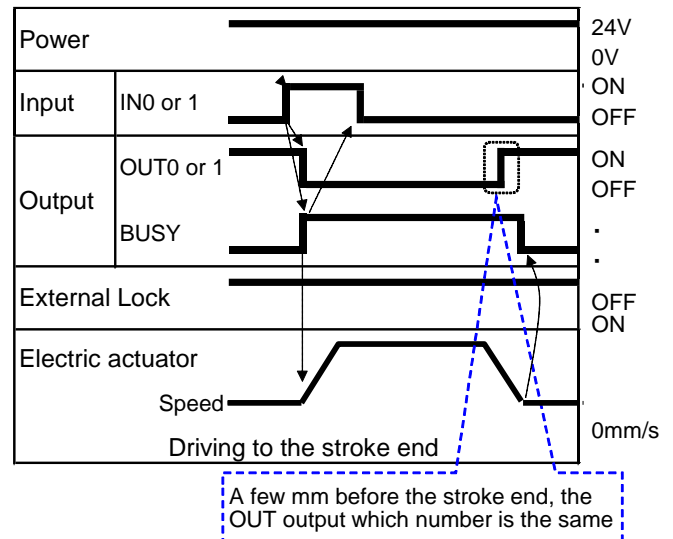

- Procedure - Driving to the intermediate position - - Timing chart-Driving to the intermediate position -

- 1) Turn on IN0 to IN3 input signals. (Inputs the position number with the binary by the combination of IN0-IN3.)
When one command is made by inputting several I/O simultaneously, the time difference between signals has to be 3 ms or less.
- ↓
- 2) BUSY is turned on. (The positioning operation starts.)
- ↓
- 3) BUSY output turns off. (The electric actuator stops)
OUT0 to OUT3 outputs corresponding to the commanded IN0 to IN3 input signals turns on.
- ↓
- 4) Driving to the intermediate position is completed.

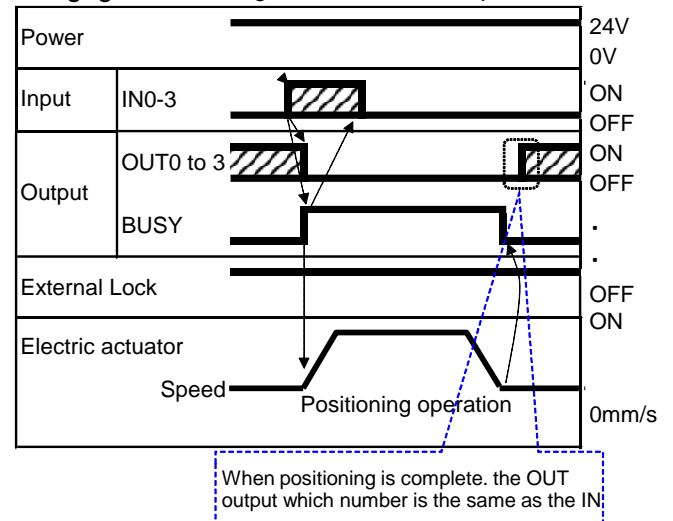

(3) Reset : Reset of the driving and Reset of the alarm

- Procedure - Reset of the driving

What is "Reset of the driving"
 Stopping method of canceling the positioning operation of the specified position number during operation and decelerating and stopping

- 1) During operation (BUSY output ON) Turn on the RESET input.
- ↓
- 2) The operation stops and the BUSY output turns off.
 All of OUT0-OUT3 outputs turn off.

- Timing chart - Reset of the driving -

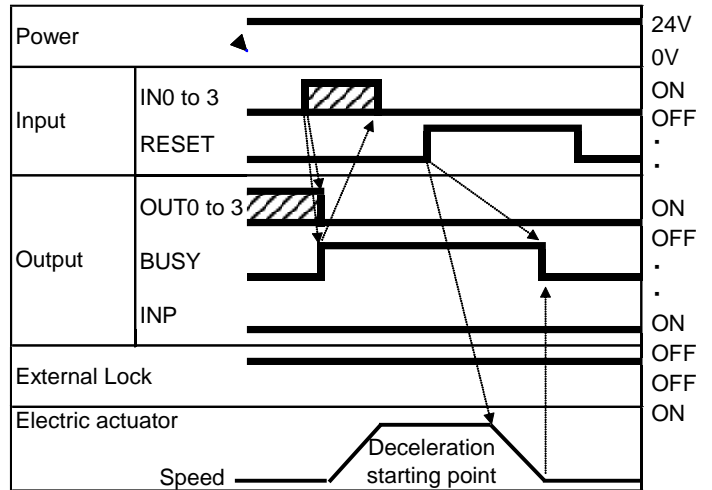

- Procedure - Reset of the alarm (Release)

- 1) Alarm occurrence
 *ALARM output turns off.
 OUT0 to OUT3 output turns on.
 (Outputs the alarm group)
- ↓
- 2) Turn on the RESET input.
- ↓
- 3) When the alarm is reset, *ALARM output turns on. Outputs OUT0 to OUT3 are all turned off.

- Timing chart - Reset of the alarm (Release)-

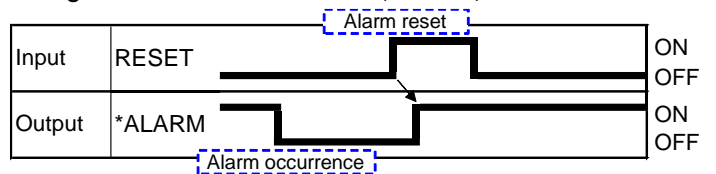

(4) STOP

- Procedure - The stop that becomes servo off state after stopping

- 1) During operation (BUSY output ON) Turn on the STOP input. (Stop instruction)
- ↓
- 2) *ALARM output turns off.
- ↓
- 3) The operation stops and the BUSY output turns off.
- ↓
- 4) Servo off (Motor is in free state).
 In case of electric actuator with lock, lock it.
- ↓
- 5) Turn off the STOP input.
 (Stop cancellation instruction)
- ↓
- 6) ALARM output turns on.
 Servo ON (state where the motor can operate).
 In case of electric actuator with lock, unlock it.

- Timing chart -

The stop that becomes servo off state after stopping -

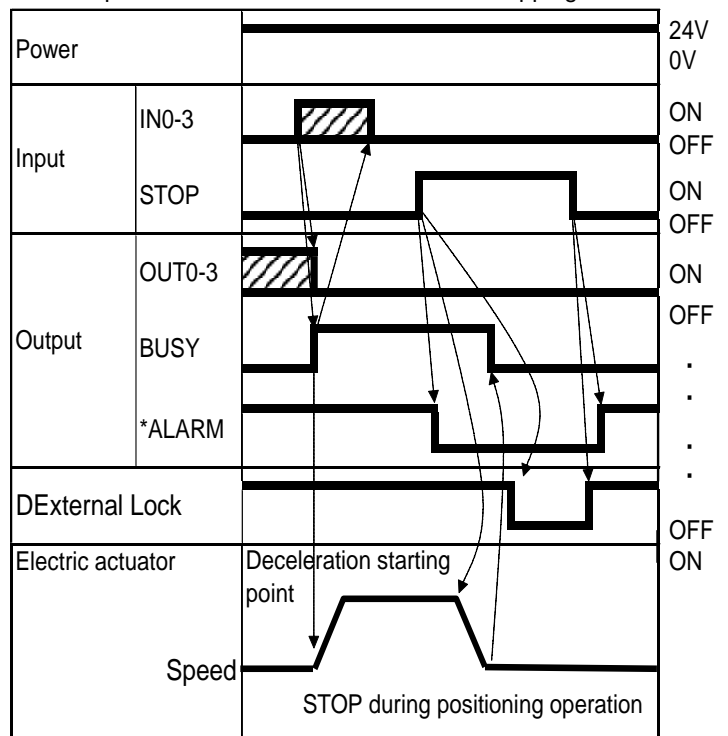

10. Initial setting value of electric actuator (LEM series)

The default setting values are shown below.

Return to origin, jog operation, inching operation are as shown in the table below.

		Common to LEM series
Return to origin	Direction	Motor side
	Speed [mm/s]	60
	Acceleration [mm/s ²]	500
Jog operation	Speed [mm/s]	48
	Acceleration [mm/s ²]	1000
Inching operation	Distance [mm]	0.12

Refer to the table below for the speed and the acceleration of the LEM series.

	LEMB / LEMC		LEMH / LEMHT	
	Speed [mm/s]	Acceleration [mm/s ²]	Speed [mm/s]	Acceleration [mm/s ²]
0	48	250	48	250
1	75	500	75	500
2	100	1000	100	1000
3	150	1500	150	1500
4	200	2000	200	2000
5	250	2500	300	2500
6	300	3000	400	3000
7	350	4000	500	4000
8	400	5000	600	5000
9	450	6000	800	6000
10	500	7500	1000	7500
11	600	10000	1200	10000
12	700	12500	1400	12500
13	800	15000	1600	15000
14	900	17500	1800	17500
15	1000	20000	2000	20000

11. Alarm Detection

Details of the alarm can be checked by the controller LED indication and parallel I/O terminal.

(During manual mode, only the 7-segment LED is ON)

When an alarm has been generated, reset the alarm after taking countermeasures and correcting the error, refer to "11.2 Alarm details"

Alarms are divided into two types. One type can be cleared by pressing the set button (g) or inputting the RESET I/O signal. The other type cannot be cleared unless the control power supply (C24V) is turned off and on once.

11.1 Alarm group output

This controller outputs signals from LED output and I/O so that the type of alarm can be determined when an alarm occurs. The alarm LED (b) of the controller is lit in red, and the 7-segment LED (f) displays the alarm group. From I/O, ALARM indicates presence / absence of alarm, and it is expressed by OUT 0 to OUT 3.

If multiple alarms occur at the same time, the 7-segment LED display will show a severe alarm group.

【 Light A – B – C – D – E Severe 】

Alarm group	7seg LED Display	Parallel output *3)					Procedure of restart
		ALARM *1), *2)	OUT0	OUT1	OUT2	OUT3	
A	A	OFF	ON	OFF	OFF	OFF	Press the set button (g) or input RESET.
B	b	OFF	OFF	ON	OFF	OFF	
C	c	OFF	OFF	OFF	ON	OFF	
D	d	OFF	OFF	OFF	OFF	ON	
E	E	OFF	OFF	OFF	OFF	OFF	The control power supply turn off ⇒ Turn on the power again

When multiple alarms in alarm groups A to D occur, the relevant OUT0 to OUT3 will be ON.

However, when alarm group E occurs, regardless of any other alarms that may be occurring, OUT0 to OUT3 will all be OFF.

*1) ALARM is turned OFF when an alarm occurs because of N.C. specification.

*2) Because the ALARM output is turned OFF even when the servo is OFF, alarm occurrence can not be identified with ALARM output only.

*3) Parallel signal output during manual mode will not turn ON.

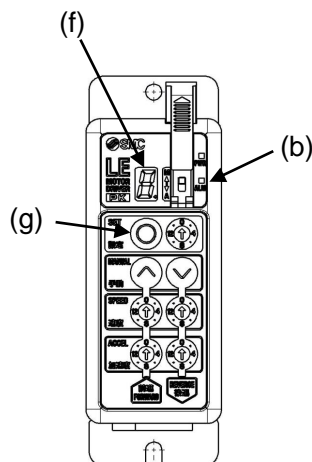

11.2 Alarm details

Group	The condition of the controller when an alarm is generated	How to reset	Alarm contents / Countermeasure
A	Manual mode Servo is OFF	Press setting button (RESET input is ON)	<p><Condition> In registering the intermediate position by Direct teaching, the alarm occurs when the position is registered before the return to origin is completed.</p> <p><Countermeasure> Perform the return to origin.</p>
B	Any condition	RESET input is ON (Press setting button)	<p><Condition> The alarm occurs when the controller's internal data or parameters are abnormal.</p> <p><Countermeasure> If the problem is not solved by supplying power again, please contact SMC.</p>
C	Stopped	RESET input is ON (Press setting button)	<p><Condition> The alarm occurs when the return to origin, positioning or a jog operation is commanded when the electric actuator is servo off state.</p> <p><Countermeasure> Check if I/O signal STOP is input. Also, check if the servo off in manual mode. Refer to 8.5 Servo ON for turning servo off.</p>
C	Stopped	RESET input is ON (Press setting button)	<p><Condition> The alarm occurs when positioning is commanded before the return to origin is completed.</p> <p><Countermeasure> Start operation after the completion of the return to origin. Return to origin must be performed after a group E alarm is generated and deactivated.</p>
D	During operation	RESET input is ON (Press setting button)	<p><Condition> Motor rotation exceeds specified value.</p> <p><Countermeasure> If an external force is being applied, remove it. If there is no external force being applied, and the problem is not solved by supplying power again, please contact SMC.</p>
D	During operation	RESET input is ON (Press setting button)	<p><Condition> It occurs when the motor power supply voltage detected inside the controller falls outside the specified range. It may occur when the regenerative power of the motor is large.</p> <p><Countermeasure> Check the voltage supplied to the power supply for the controller motor (M24V). Check if the operating condition of the electric actuator is within the specification range.</p> <div style="border: 1px solid black; padding: 5px; text-align: center;"> <p>⚠ Caution</p> </div> <p>If the power supply is an inrush current suppressor type, a voltage drop may occur during acceleration / deceleration, generating an alarm.</p>

D	Any condition	RESET input is ON (Press setting button)	<p><Condition> The temperature around the power element of the controller is too high.</p> <p><Countermeasure> Improve the peripheral environment of the controller after checking the installation of the controller. Refer to 3.4 How to install for the mounting conditions of the controller.</p>
D	Any condition	RESET input is ON (Press setting button)	<p><Condition> It occurs when the control power supply voltage detected inside the controller falls outside the specified range</p> <p><Countermeasure> Please check the voltage supplied to the control power supply (C24V) of the controller.</p> <div style="border: 1px solid black; background-color: #cccccc; padding: 2px; text-align: center;">  Caution </div> <p>If a single power supply is used for both the control power and the motor power, or the power supply is “inrush current suppression type”, a power voltage drop may occur during acceleration / deceleration, generating an alarm.</p>
D	During or after suspension of operation	RESET input is ON (Press setting button)	<p><Condition> The time to reach the target position is longer than the specified value.</p> <p><Countermeasure> Check that the electric actuator’s move is not interrupted. If you are adjusting the stopper, perform stroke learning and re-registration of all intermediate positions.</p>
E	Immediately after turning on the power	Control power supply is shut down	<p><Condition> This alarm occurs when an abnormality is detected in the encoder signals.</p> <p><Countermeasure> Please check whether there are any loose connections or any damage to the connector of the controller and / or electric actuator. Please check whether there is any damage to the actuator cable (severed wires, etc.).</p>
E	Immediately after turning on the power	Control power supply is shut down	<p><Condition> Positioning of the polarity is not finished properly. When the power is supplied, the electric actuator slightly moves to detect the polarity of the motor. This alarm is generated when the electric actuator cannot be moved.</p> <p><Countermeasure> Supply power in conditions in which the electric actuator is operable.</p>
E	Immediately after turning on the power	Control power supply is shut down	<p><Condition> An abnormality is confirmed with the current sensors which are recognized when the controller is initialized.</p> <p><Countermeasure> Please check that the motor is not operated by external force during servo ON. Install the electric actuator vertically and check that the BK RLS is not energized. Confirm the combination of the controller and the electric actuator is correct. If the problem is not solved by supplying power again, please contact SMC.</p>
E	During operation	Control power supply is shut down	<p><Condition> Position deviation counter in the controller has overflowed.</p> <p><Countermeasure> Check that the electric actuator’s move is not interrupted. Check if the load of the electric actuator is within the specification range.</p>

E	Any condition	Control power supply is shut down	<p><Condition> Output current at the power supply circuit is abnormally high.</p> <p><Countermeasure> Check if the actuator cable or connector is short-circuited. Confirm the combination of the controller and the electric actuator is correct.</p>
E	Any condition	Control power supply is shut down	<p><Condition> Abnormality concerning EEPROM is confirmed.</p> <p><Countermeasure> If the problem is not solved by supplying power again, please contact SMC. (The write limit of the EEPROM is roughly 100,000 times)</p>
E	Any condition	Control power supply is shut down	<p><Condition> CPU is not operating properly. (Failure of CPU and peripheral circuits, or malfunction due to noise)</p> <p><Countermeasure> If the problem is not solved by supplying power again, please contact SMC.</p>

12. Wiring of cables / Common precautions

Warning

- (1) **Adjusting, mounting or wiring change should never be done before shutting off the power supply to the product.**
Electrical shock, malfunction and damage can result.
- (2) **Never disassemble the cable. Use only specified cables.**
- (3) **Do not remove or connect the cable and connector while power is supplied.**

Caution

- (1) **Wire the connector securely. Do not apply any voltage to the terminals other than those specified in the product Manual.**
- (2) **Wire the connector securely.**
Check for correct connector wiring and polarity.
- (3) **Take appropriate measures against noise.**
Noise in a signal line may cause malfunction. As a countermeasure, separate high voltage and low voltage cables, and shorten wiring lengths, etc.
- (4) **Do not route wires and cables together with power or high voltage cables.**
The product can malfunction due to interference of noise and surge voltage from power and high voltage cables to the signal line. Route the wires of the product separately from power or high voltage cables.
- (5) **Take care that electric actuator movement does not catch cables.**
- (6) **Operate with cables secured. Avoid bending cables at sharp angles where they enter the product.**
- (7) **Avoid twisting, folding, rotating or applying an external force to the cable.**
Risk of electric shock, wire break, contact failure and loss of control for the product can happen.
- (8) **Fix the motor cable protruding from the product in place before using.**
The motor and lock cables are not robotic type cables and can be damaged when moved. Therefore, do not place A part below it in a flexible moving tube.

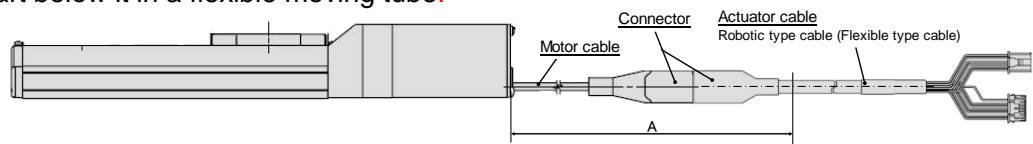

- (9) **Select “Robotic type cables” in case of inflecting the electric actuator-cable repeatedly. And do not put cables into a flexible moving tube with a radius smaller than the specified value. (Min. 50mm).**

Risk of electric shock, wire break, contact failure and loss of control for the product can happen if “Standard cables” are used in case of inflecting the cables repeatedly.

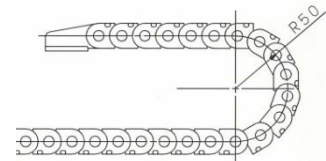

- (10) **Confirm proper wiring of the product.**

Poor insulation (interference with other circuits, poor insulation between terminals and etc.) can apply excessive voltage or current to the product causing damage.

- (11) **The Speed / pushing force may vary, depending on the cable length, load and mounting conditions etc.**

If the cable length exceeds 5m, the speed / pushing force will be reduced by a maximum of 10% per 5m. (If cable length is 15m: Maximum 20% reduction.)

[Transportation]

Caution

- (1) **Do not carry or swing the product by the motor or the cable.**

13. Electric actuators / Common precautions

13.1 Design and selection

Warning

(1) Be sure to read the Operation Manual.

Handling or usage / operation other than that specified in the Operation Manual may lead to breakage and operation failure of the product.

Any damage attributed to the use beyond the specifications is not guaranteed.

(2) There is a possibility of dangerous sudden action by the product if sliding parts of machinery are twisted due to external forces etc.

In such cases, human injury may occur, such as by catching hands or feet in the machinery, or damage to the machinery itself may occur. Design the machinery should be designed to avoid such dangers.

(3) A protective cover is recommended to minimize the risk of personal injury.

If a driven object and moving parts of the product are in close proximity, personal injury may occur. Design the system to avoid contact with the human body.

(4) Securely tighten all stationary parts and connected parts so that they will not become loose.

When the product operates with high frequency or is installed where there is a lot of vibration, ensure that all parts remain secure.

(5) Consider a possible loss of power source.

Take measures to prevent injury and equipment damage even in the case of a power source failure.

(6) Consider behavior of emergency stop of whole system.

Design the system so that human injury and / or damage to machinery and equipment will not be caused, when it is stopped by a safety device for abnormal conditions such as a power outage or a manual emergency stop of whole system.

(7) Consider the action when operation is restarted after an emergency stop or abnormal stop of whole system.

Design the system so that human injury or equipment damage will not occur upon restart of operation of whole system.

(8) Disassembly and modification prohibited

Do not modify or reconstruct (including additional machining) the product. An injury or failure can result.

(9) When using it for vertical application, it is necessary to build in a safety device.

The rod may fall due to the weight of work. The safety device should not interfere with normal operation of the machine.

Caution

(1) Operate within the limits of the maximum usable stroke.

The product will be damaged if it is used with the stroke which is over the maximum stroke. Refer to the specifications of the product.

(2) When the product repeatedly cycles with partial strokes, operate it at a full stroke at least once a day or every 1000 strokes.

Otherwise, lubrication can run out.

(3) Do not use the product in applications where excessive external force or impact force is applied to it.

The product can be damaged. Each component that includes motor is made with accurate tolerance. So even slightly deformed or miss-alignment of component may lead operation failure of the product.

(4) Return to origin cannot return while operating.

It cannot be done during positioning operation, pushing operation and pushing.

(5) Refer to a common auto switch / matter (Best Pneumatics No 2) when an auto switch is built in and used.

(6) When conformity to UL is required, the electric actuator and controller should be used with a UL1310 Class 2 power supply.

13.2 Mounting

Warning

- (1) Install and operate the product only after reading the Operation Manual carefully and understanding its contents. Keep the manual in a safe place future reference.**
- (2) Observe the tightening torque for screws.**

Tighten the screws to the recommended torque for mounting the product.
- (3) Do not make any alterations to this product.**

Alterations made to this product may lead to a loss of durability and damage to the product, which can lead to human injury and damage to other equipment and machinery.
- (4) When using external guide, the guide axis should be parallel to the electric actuator axis.**

There will be damage / excessive wear on the lead screw if the external guide is not parallel.
- (5) When an external guide is used, connect the moving parts of the product and the load in such a way that there is no interference at any point within the stroke.**

Do not scratch or dent the sliding parts of the product tube or piston rod etc., by striking or grasping them with other objects. Components are manufactured to precise tolerances, so that even a slight deformation may cause faulty operation.
- (6) Prevent the seizure of rotating parts.**

Prevent the seizure of rotating parts (pins, etc.) by applying grease.
- (7) Do not use the product until you verify that the equipment can be operated properly.**

After mounting or repair, connect the power supply to the product and perform appropriate functional inspections to check it is mounted properly.
- (8) At the overhang mounted impeller fixation**

There is a possibility that the power at the bending moment damages the electric actuator when moving it at high speed.

The support metal fittings that suppress the vibration of the main body of the electric actuator are installed.

Lower and use speed for the state that the electric actuator doesn't vibrate.
- (9) When mounting the electric actuator or attaching to the work piece, do not apply strong impact or large moment.**

If an external force over the allowable moment is applied, it may cause looseness in the guide unit, an increase in sliding resistance or other problems.
- (10) Maintenance space.**

Allow sufficient space for maintenance and inspection.

13.3 Precautions for Use

Warning

- (1) Do not touch the motor while in operation.**

The surface temperature of the motor can increase to approx. 90 °C to 100 °C due to operating conditions. Energizing alone may also cause this temperature increase. As it may cause burns, do not touch the motor when in operation.
- (2) If abnormal heating, smoking or fire, etc., occurs in the product, immediately shut off the power supply.**
- (3) Immediately stop operation if abnormal operation noise or vibration occurs.**

The product may have been mounted incorrectly. Unless operation of the product is stopped for inspection, the product can be seriously damaged.
- (4) Never touch the rotating part of the motor or moving part of the electric actuator while in operation.**
- (5) When installing, adjusting, inspecting or performing maintenance on the product, controller and related equipment, be sure to shut off the power supply to each of them. Then, lock it so that no one other than the person working can turn the power on, or implement measures such as a safety plug.**

Caution

(1) Keep the controller and product combined as delivered for use.

The product is set in parameters for shipment. If it is combined with a different parameter, failure can result.

(2) Check the product for the following points before operation.

- a) Damage to electric driving line and signal lines
- b) Looseness of the connector to each power line and signal line
- c) Looseness of the electric actuator / cylinder and controller / driver mounting
- d) Abnormal operation
- e) Emergency stop of the total system

(3) When more than one person is performing work, decide on the procedures, signals, measures and resolution for abnormal conditions before beginning the work. Also, designate a person to supervise work other than those performing work.

(4) Actual speed of the product will be changed by the workload.

Before selecting a product, check the catalog for the instructions regarding selection and specifications.

(5) Do not apply a load, impact or resistance in addition to a transferred load during return to origin.

In the case of the return to origin by pushing force, additional force will cause displacement of the origin position since it is based on detected motor torque.

(6) Do not remove the nameplate.

(7) Operation test should be done by low speed. Start operation by predefined speed after confirming there is no trouble.

[Ground]

Warning

(1) Be sure to ground the electric actuator.

(2) Grounding should be dedicated ground.

Ground construction is Class D grounding. (Ground resistance 100 Ω or less)

(3) Make the grounding as close as possible to the electric actuator and shorten the distance to ground.

[Unpackaging]

Caution

(1) Check the received product is as ordered.

If a different product is installed from the one ordered, injury or damage can result.

13.4 Operating environment

Warning

(1) Do not use the product in environment below.

1. Locations where a large amount of dusts and cutting chips are airborne.
2. Locations where the ambient temperature is outside the range of the temperature specification (refer to specifications).
3. Locations where the ambient humidity is outside the range of the humidity specification (refer to specifications).
4. Locations where corrosive gas, flammable gas, seawater, water and steam are present.
5. Locations where strong magnetic or electric fields are generated.
6. Locations where direct vibration or impact is applied to the product.
7. Areas that are dusty, or are exposed to splashes of water and oil drops.
8. Areas exposed to direct sunlight (ultraviolet ray).
9. Environment at an altitude of 1000 meters or higher

Heat radiation and withstand voltage will decrease. Contact SMC for details.

(2) Do not use in an environment where the product is directly exposed to liquid, such as cutting oils.

If cutting oils, coolant or oil mist contaminates the product, failure or increased sliding resistance can result.

(3) Install a protective cover when the product is used in an environment directly exposed to foreign matters such as dust, cutting chips and spatter.

Play or increased sliding resistance can result.

(4) Shade the sunlight in the place where the product is applied with direct sunshine.

(5) Shield the valve from radiated heat generated by nearby heat sources.

The radiated heat from the heat source can increase the temperature of the product beyond the operating temperature range.

(6) Grease oil can be decreased due to external environment and operating conditions, and it deteriorates lubrication performance to shorten the life of the product.

[Storage]

Warning

(1) Do not store the product in direct contact with rain or water drops or is exposed to harmful gas or liquid.

(2) Store in an area that is shaded from direct sunlight and has a temperature and humidity within the specified range (-10 °C to 60 °C and 35 to 85% No condensation or freezing).

(3) Do not apply vibration and impact to the product during storage.

13.5 Maintenance

Warning

(1) Do not disassemble or repair the product.

Fire or electric shock can result.

(2) Before modifying or checking the wiring, the voltage should be checked with a tester 5 minutes after the power supply is turned off.

Electrical shock can result.

Caution

(1) Maintenance should be performed according to the procedure indicated in the Operating Manual.

Incorrect handling can cause injury, damage or malfunction of equipment and machinery.

(2) Removal of product.

When equipment is serviced, first confirm that measures are in place to prevent dropping of work pieces and run-away of equipment, etc., and then cut the power supply to the system. When machinery is restarted, check that operation is normal with the electric actuators in the proper positions.

(3) When moving the electric actuator slider manually by hand, please disconnect the actuator cable.

The electric actuator cannot be moved smoothly by the induced voltage of the motor goes to the controller when the electric actuator slider is moved with the electric actuator connected with the controller. Moreover, the controller might break down by the induced voltage when moving the electric actuator slider at high frequency.

[Lubrication]

Caution

(1) The product has been lubricated for life at manufacturer, and does not require lubrication in service.

Contact SMC if lubrication will be applied.

13.6 Precautions for electric actuator with lock

Warning

(1) Do not use the lock as a safety lock or a control that requires a locking force.

The lock used for the product with a lock is designed to prevent dropping of work piece.

(2) For vertical mounting, use the product with a lock.

If the product is not equipped with a lock, the product will move and drop the work piece when the power is removed.

(3) “Measures against drops” means preventing a work piece from dropping due to its weight when the product operation is stopped and the power supply is turned off.

(4) Do not apply an impact load or strong vibration while the lock is activated.

If an external impact load or strong vibration is applied to the product, the lock will lose its holding force and damage to the sliding part of the lock or reduced lifetime can result. The same situations will happen when the lock slips due to a force over the thrust of the product, as this accelerates the wear to the lock.

(5) Do not apply liquid or oil and grease to the lock or its surrounding.

When liquid or oil and grease is applied to the sliding part of the lock, its holding force will reduce significantly.

(6) Take measures against drops and check that safety is assured before mounting, adjustment and inspection of the product.

If the lock is released with the product mounted vertically, a work piece can drop due to its weight.

(7) When the electric actuator is operated manually (when SVRE output signal is off), supply 24 VDC to the [BK RLS] terminal of the power supply connector.

If the product is operated without releasing the lock, wearing of the lock sliding surface will be accelerated, causing reduction in the holding force and the life of the locking mechanism.

(8) Do not supply 24 VDC power supply constantly to the [BK RLS (Lock release)] terminal.

Stop supplying 24 VDC power supply to the [BK RLS (Lock release)] terminal during normal operation. If power is supplied to the [BK RLS] terminal continuously, the lock will be released, and work pieces may be dropped at stop (EMG).

/ Refer to the operation manual of LEC (controller) for details of wiring.

14. Controller and its peripheral devices / Specific product precautions

14.1 Design and selection

Warning

(1) Be sure to apply the specified voltage.

Otherwise, a malfunction and breakage of the controller may be caused.

If the applied voltage is lower than the specified, it is possible that the load cannot be moved due to an internal voltage drop. Please check the operating voltage before use.

(2) Do not operate beyond the specifications.

It may cause a fire; malfunction or the electric actuator damage can result. Please check the specifications before use.

(3) Install an emergency stop circuit.

Please install an emergency stop outside of the enclosure so that it can stop the system operation immediately and intercept the power supply.

(4) In order to prevent danger and damage due to the breakdown and the malfunction of this product, which may occur at a certain probability, a backup system should be established previously by giving a multiple-layered structure or a fail-safe design to the equipment, etc.

(5) If a fire or danger against the personnel is expected due to an abnormal heat generation, ignition, smoking of the product, etc., cut off the power supply for this product and the system immediately.

14.2 Handling

Warning

(1) The inside of the controller and its connector should not be touched.

It may cause an electric shock or damage to the controller.

(2) Do not perform the operation or setting of this equipment with wet hands.

It may cause an electric shock.

(3) Product with damage or the one lacking of any components should not be used.

It may cause an electric shock, fire, or injury.

(4) Use only the specified combination between the controller and the electric actuator.

It may cause damage to the controller or the electric actuator.

(5) Be careful not to be caught or hit by the work piece while the electric actuator is moving.

It may cause an injury.

(6) Do not connect the power supply or power on the product before confirming the area where the work moves is safe.

The movement of the work may cause accident.

(7) Do not touch the product when it is energized and for some time after power has been disconnected, as it is very hot.

It may lead to a burn due to the high temperature.

(8) Check the voltage using a tester for more than 5 minute after power-off in case of installation, wiring and maintenance.

There is a possibility of getting electric shock, fire and injury.

(9) Do not use in an area where dust, powder dust, water or oil is in the air.

It will cause failure or malfunction.

(10) Do not use in an area where a magnetic field is generated.

It will cause failure or malfunction.

(11) Do not install in the environment of flammable gas, corrosive gas and explosive gas.

It could lead to fire, explosion and corrosion.

(12) Do not apply radiant heat from a large heat source such as direct sunlight or heat treatment furnace.

It will cause failure of the controller or its peripheral devices.

(13) Do not use the product in an environment subject to a temperature cycle.

It will cause failure of the controller or its peripheral devices.

(14) Do not use in a place where surges are generated.

When there are units that generate a large amount of surge around the product (e.g., solenoid type lifters, high frequency induction furnaces, motors, etc.), this may cause deterioration or damage to the product's internal circuit. Avoid supplies of surge generation and crossed lines.

(15) Do not install this product in an environment under the effect of vibrations and impacts.

It will cause failure or malfunction.

(16) If this product is used with a relay or solenoid valve, they should be the surge absorbing element built-in type.

14.3 Installation

⚠ Warning

(1) The controller and its peripheral devices should be installed on a fire-proof material.

A direct installation on or near a flammable material may cause fire.

(2) Do not install this product in a place subject to vibrations and impacts.

It may cause an electric shock, fire, or injury.

(3) Take measure so that the operating temperature of this controller and its peripheral devices are within the range of the specifications. Also, this controller should be installed with 50mm or larger spaces between each side of it and the other structures or components.

It may cause a malfunction of the controller and its peripheral devices and a fire.

(4) Do not mount this controller and its peripheral devices together with a large-sized electromagnetic contactor or no-fuse breaker, which generates vibration, on the same panel. Mount them on different panels, or keep the controller and its peripheral devices away from such a vibration supply.

(5) This controller and its peripheral devices should be installed on a flat surface.

If the mounting surface is distorted or not flat, an unacceptable force may be added to the housing, etc. to cause troubles.

14.4 Wiring

⚠ Warning

(1) Do not apply any excessive force to cables by repeated bending, tensioning or placing a heavy object on the cables.

It may cause an electric shock, fire, or breaking of wire.

(2) Connect wires and cables correctly.

Incorrect wiring could break the controller or its peripheral devices depending on the seriousness.

(3) Do not connect wires while the power is supplied.

It can break the controller or its peripheral devices could be damaged to cause a malfunction.

(4) Do not carry this product by holding its cables.

It may cause an injury or damage to the product.

(5) Do not connect power cable or high-voltage cable in the same wiring route as the unit.

The wires to the controller or its peripheral devices can be interrupted with noise or induced surge voltage from power lines or high-voltage lines and malfunction could be caused.

Separate the wiring of the controller and its peripheral device from that of power line and high voltage line.

(6) Verify the insulation of wiring.

Insulation failure (interference with other circuit, poor insulation between terminals and etc.) could introduce excessive voltage or current to the controller or its peripheral devices and damage them.

14.5 Power supply

Warning

- (1) **Use a power supply that has low noise between lines and between power and ground.**
In cases where noise is high, an isolation transformer should be used.
- (2) **The power supplies should be separated between the controller power and the I/O signal power and both of them do not use the power supply of “inrush current restraining type”.**
If the power supply is “inrush current restraining type”, a voltage drop may be caused during the acceleration of the electric actuator.
- (3) **To prevent surges from lightning, an appropriate measure should be taken. Ground the surge absorber for lightning separately from the grounding of the controller and its peripheral devices**

14.6 Grounding

Warning

- (1) **Be sure to ground to ensure noise immunity of the controller.**
It may cause an electric shock or fire.
- (2) **Controller mount hole (mounting part for ground cable) is connected to SG (signal ground) in the controller.**
Do not ground the controller when the controller is used in positive grounding environment.
- (3) **Dedicated grounding should be used.**
Grounding should be to a D-class ground (Ground resistance of 100 Ω or less.)
- (4) **Grounding should be performed near the unit as much as possible to shorten the grounding distance.**
- (5) **In the unlikely event that malfunction is caused by the ground, it may be disconnected.**

14.7 Maintenance and inspection

Warning

- (1) **Perform a maintenance check periodically.**
Confirm wiring and screws are not loose.
Loose screws or wires may cause unintentional malfunction.
- (2) **Conduct an appropriate functional inspection after completing the maintenance.**
In case of any abnormalities (in the case that the electric actuator does not move, etc.), stop the operation of the system. Otherwise, an unexpected malfunction may occur and it will become impossible to secure the safety.
- (3) **Do not disassemble, modify or repair this controller and the peripheral equipment.**
- (4) **Do not put anything conductive or flammable inside of this controller.**
It may cause a fire and explosion.
- (5) **Do not conduct an insulation resistance test and withstand voltage test on this product.**
- (6) **Ensure sufficient space for maintenance activities. Provide space required for maintenance.**
Design the system that allows required space for maintenance.

15. Troubleshooting

In case of any troubles, please consult the following table.

Consider replacing controller, if not of the causes on this table are applicable.

It is possible that this product is damaged due to the operating conditions (applications), please contact SMC to discuss appropriate measures.

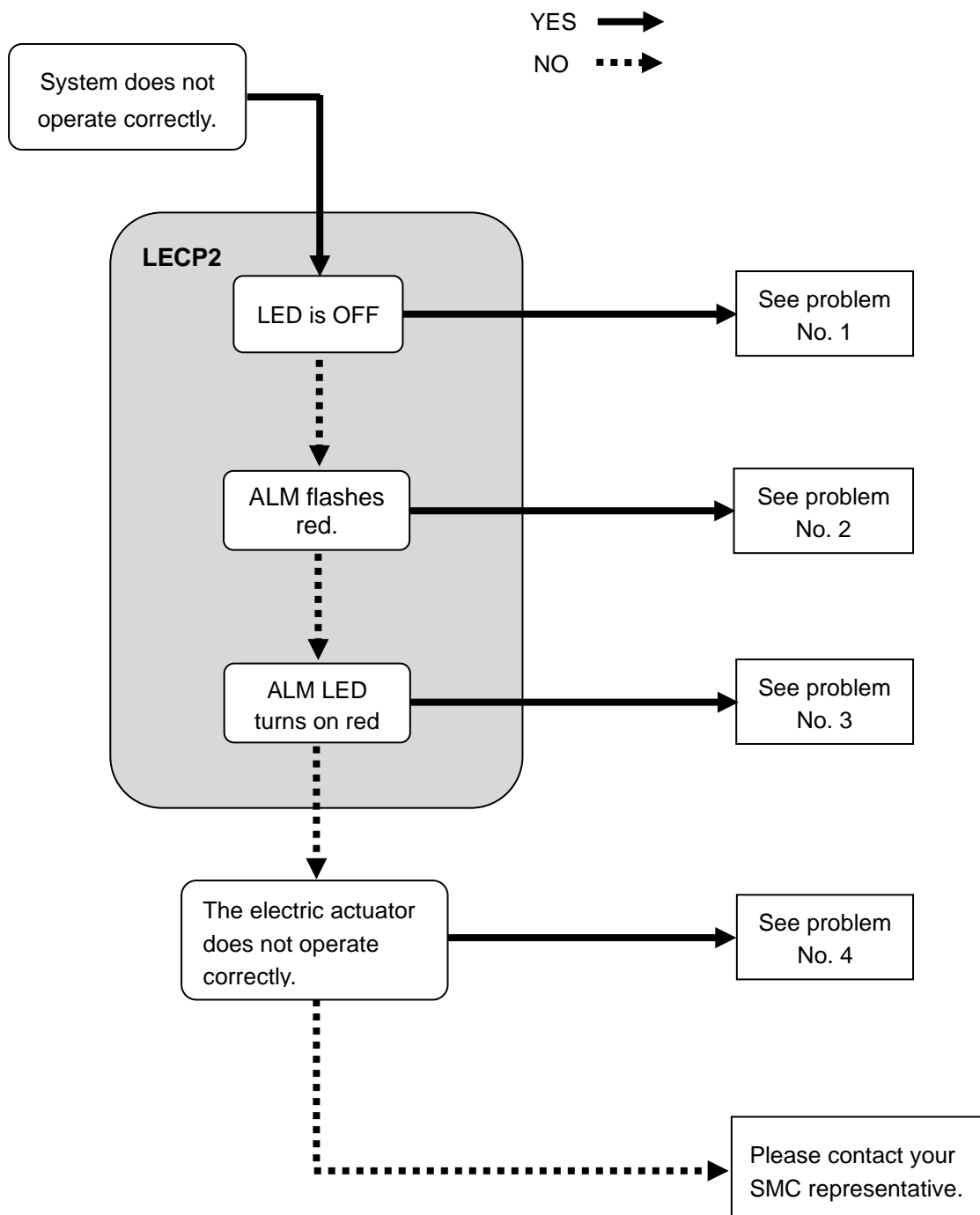

Trouble No.	Trouble	Possible cause	How to diagnose the trouble	Solutions
1	LED is OFF	Power fault	Check if the LED (green) of the controller is lit.	The power supply, voltage or current should be modified to an appropriate one. → 4. External Wiring Diagram → 5. CN1: Power supply cable
		Wiring fault	Is the wiring connected correctly?	Check if the wiring is connected correctly or if there is broken wire or short-circuit by referring to this Operation Manual. Correct the wiring and check that the input / output of each signal is correct. Separate the power supply for the CN1 controller and the CN4 I/O signal power supply. → 4. External Wiring Diagram → 6.4 Parallel I/O Wiring Example
2	Flashing ALM	Stroke study is not completed	Just after the power supply is supplied to the controller, is ALM LED (red) flashing?	Flashing of the controller ALM LED (red) immediately after power supply indicates the stroke study has not been performed. Please perform Stroke study. → 7.1(3) Stroke study
3	ALM is ON	Alarm condition	Check if the controller is in the alarm condition.	Refer to the instruction manual of the controller and confirm the type of alarm. Take appropriate measures according to the contents. → 11. Alarm Detection
4	The electric actuator does not move at all.	Lock release error	Check if you can hear the sound of lock release when the manual lock switch is turned on and off.	If there is no sound of lock release from the electric actuator with lock, the lock may be broken. If the trouble continues, please contact SMC.
		External device fault	Check that the PLC connected to the controller operates correctly.	Make a confirmation of operation by a test run only with the controller. Take appropriate measures by referring to the Operation Manual for the controller. → 6. CN4: Parallel I/O Connector
		Servo OFF	Is servo OFF (controller green LED flashes)?	Servo is OFF and the operation is not available under the following conditions. Eliminate the cause and follow the operation instruction after the servo is turned ON. - STOP input is ON. - Motor power supply is OFF.
	Move occasionally	Wiring fault	Is the wiring connected correctly?	Check if the wiring is connected correctly or if there is broken wire or short-circuit by referring to this Operation Manual. Correct the wiring and check that the input / output of each signal is correct. Separate the power supply for the CN1 controller and the CN4 I/O signal power supply. → 4. External Wiring Diagram → 6.4 Parallel I/O Wiring Example
Counter-measures against noise		Check that the Grounding is connected correctly? Are power cables for other equipment and controller cables bundled together?	Connect to Ground correctly. Avoid bundling the cables with power cables of other equipment. Take appropriate measures by referring to the Operation Manual for the controller. → 3.4 How to install	

	Voltage drop	Check for a temporary voltage drop in the power supply?	There is a possibility of a momentary voltage drop because the capacity of the power supply is insufficient, or if the power supply has "inrush current suppression type". → 3.1 Basic specifications
	Inappropriate specifications	Check if a product with a suitable specification was selected. Reconfirm the combination of the power supply and the electric actuator and controller.	Check if the product number of the used electric actuator matches with the electric actuator which is applicable to the controller. → 2.3 How to Order
	Servo on time	When the power supply for the motor is applied (or STOP input is turned off), commands can be given after ALARM output is ON?	Just after the motor power is supplied, it may take 10 seconds until ALARM output depending on the electric actuator position. Command operation after ALARM output is turned ON.
	Alarm occurring	Is the controller alarm occurring?	Refer to the instruction manual of the controller and confirm the type of alarm. Take appropriate measures according to the contents. → 11. Alarm Detection
	Command the position number repeatedly	Same position number specified?	The operation is not performed when the position number of the current stop position is specified repeatedly. There is no operation start either when the position number to which the current stop position number is registered is specified. Check if the position number specified before operation, the position number which specifies the position and operation, and the registered position number are not overlapped.
	Signal timing	Check the timing of the signal from the PLC to the controller.	PLC processing delay and controller scan delay are generated. Please ensure an interval of 15ms (30 ms if possible) or more between input signals, and maintain the signal state. → 8.5 Response time for the controller input signal
The electric actuator does not move to the correct position.	Incorrect origin position	If it is a pushing operation, repeat return to origin operations several times to check if the electric actuator returns to origin correctly.	Perform the return to origin position operation several times to check the origin position. Take measures to make the electric actuator operate normally (remove foreign matter that interferes with the actuator movement, etc.)
	Change of movable stroke	Was the stopper of electric actuator adjusted?	Check the set position of the stopper of electric actuator. Perform the stroke study when adjusting the stopper of electric actuator. → 7.1(3) Stroke study → 7.1(7) Intermediate position setting
		After performing Stroke study, were all the intermediate positions re-registered?	After learning the stroke, be sure to register all intermediate positions (position numbers 3 to 14 (E)) again. → 7.1(7) Intermediate position setting
	Inappropriate specifications	Check that the combination of the electric actuator and controller is correct?	Check if the product number of the used electric actuator matches with the electric actuator which is applicable to the controller. → 2.3 How to Order

4	Doesn't move to the correct position.	Change of movable stroke	Was the stopper of electric actuator adjusted?	Check the set position of the stopper of electric actuator. Perform the stroke study when adjusting the stopper of electric actuator. → 7.1(3) Stroke study → 7.1(7) Intermediate position setting
			After performing Stroke study, were all the intermediate positions re-registered?	After learning the stroke, be sure to register all intermediate positions (position numbers 3 to 14 (E)) again. →7.1(7) Intermediate position setting
		Wiring fault	Is the wiring connected correctly?	Check if the wiring is connected correctly or if there is broken wire or short-circuit by referring to this Operation Manual. Correct the wiring and check that the input / output of each signal is correct. Separate the power supply for the CN1 controller and the CN4 I/O signal power supply. → 4. External Wiring Diagram → 6.4 Parallel I/O Wiring Example
		Inappropriate specifications	Check that the combination of the electric actuator and controller is correct?	Check if the product number of the used electric actuator matches with the electric actuator which is applicable to the controller. → 2.3 How to Order
		Signal timing	Check the timing of the signal from the PLC to the controller.	PLC processing delay and controller scan delay are generated. Please ensure an interval of 15ms (30 ms if possible) or more between input signals, and maintain the signal state. → 8.5 Response time for the controller input signal
	Insufficient speed	Inappropriate step data	Is the operation pattern trapezoidal?	In case of such operation, the electric actuator may start slowing down before it reaches the maximum speed. Modify the setting to make the moving distance longer or the acceleration larger. → 7.1 Setting procedure
		Inappropriate specifications	Check that the combination of the electric actuator and controller is correct? Check if the electric actuator is operating within the specification range.	Check if the product number of the used electric actuator matches with the electric actuator which is applicable to the controller. Check if the operating condition of the electric actuator is within the specification range. → 2.3 How to Order
		Speed change in auto mode	Change the value of the speed or acceleration switch in auto mode.	Go to speed adjustment in auto mode to change the speed and acceleration. → 7.2 Setting of the speed and the acceleration
		Voltage drop	Check if there has been any temporary voltage drop in the power supply. (If there is a temporary voltage drop in the power supply, the EMG terminal of CN1 power connector will turn OFF so the electric actuator will stop. However, this stop will be released when the voltage recovers.)	There is a possibility of a momentary voltage drop because the capacity of the power supply is insufficient, or the power supply has inrush current suppression type. → 3. Product Specifications

SMC Corporation

4-14-1, Sotokanda, Chiyoda-ku, Tokyo 101-0021 JAPAN
Tel: + 81 3 5207 8249 Fax: +81 3 5298 5362
URL <https://www.smcworld.com>

Note: Specifications are subject to change without prior notice and any obligation on the part of the manufacturer.
© 2013-2019 SMC Corporation All Rights Reserved



Revision history

No. LEC-OM06401

Mar / 2013 1st printing

No. LEC-OM06402

Apr / 2013 Revision

No. LEC-OM06403

Jan / 2014 Revision
Addition/Troubleshooting

No. LEC-OM06404

Jul / 2014 Revision
Addition/Troubleshooting

No. LEC-OM06405 (No. JXC※-OMT0059)

Mar / 2017 Revision

- Reviewed 5.2 Description of Wiring of the power supply cable.
- Added display and output when multiple numbers of alarms are generated.
- Added the content of Alarm group E.

No. JXC※-OMU0030-A

Jun / 2019 Complete revision

No. JXC※-OMU0030-B

Feb / 2025 Revision of Safety Instructions