



# Operation Manual

## PRODUCT NAME

***Electric Actuator/Slider Type  
compatible with manifold controller***

《 *Battery less absolute encoder type (step motor DC24V)* 》

Model / Series / Number

# LE2FS series

Applicable models : LE2FS□H

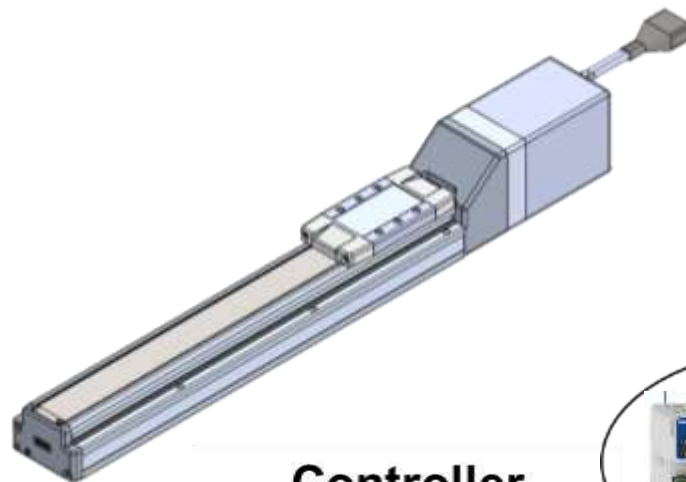

**Controller  
JXD1-M□ Series**



\* The descriptions in this operation manual are based on the selection of "**Controller/JXD1-M\***".  
\* For details of the controller, please refer to the operation manual of the controller as well.

# SMC Corporation

<b>Safety Precautions</b> .....	<b>2</b>
<b>Safety Precautions</b> .....	<b>3</b>
Precautions for product specific.....	4
<b>1 Outlines of Product</b> .....	<b>23</b>
1.1 System configuration example.....	23
1.2 Features .....	23
1.3 How to Order .....	24
1.4 Specifications .....	25
1.5 Construction.....	28
1.6 Accessories .....	29
<b>2 Installation and Initial Setting</b> .....	<b>30</b>
2.1 Flow procedure from installation to initial setting.....	30
2.2 Check the contents of the package .....	31
2.3 Preparation of necessary supplies .....	31
2.4 Installation of electric actuators .....	32
2.5 Wiring and Connection.....	33
2.6 Test run.....	33
<b>3 Operation</b> .....	<b>33</b>
<b>4 Operation Guide</b> .....	<b>34</b>
<b>5 Alarm</b> .....	<b>34</b>
<b>6 Troubleshooting</b> .....	<b>34</b>
<b>7 Setting</b> .....	<b>35</b>
7.1 Parameter .....	35
<b>8 Options</b> .....	<b>38</b>
8.1 Actuator cable .....	38



# Electric Actuator/Slider Type compatible with manifold controller Safety Precautions

These safety instructions are intended to prevent hazardous situations and/or equipment damage. These instructions indicate the level of potential hazard with the labels of “Caution,” “Warning” or “Danger.”

They are all important notes for safety and must be followed in addition to International Standards (ISO/IEC) \*1), and other safety regulations.

\*1) ISO 4414: Pneumatic fluid power - General rules and safety requirements for systems and their components

ISO 4413: Hydraulic fluid power - General rules and safety requirements for systems and their components

IEC 60204-1: Safety of machinery - Electrical equipment of machines - Part 1: General requirements

ISO 10218-1: Robots and robotic devices - Safety requirements for industrial robots - Part 1: Robots

etc



## Danger

**Danger** indicates a hazard with a high level of risk which, if not avoided, will result in death or serious injury.



## Warning

**Warning** indicates a hazard with a medium level of risk which, if not avoided, could result in death or serious injury.



## Caution

**Caution** indicates a hazard with a low level of risk which, if not avoided, could result in minor or moderate injury.

## Warning

### 1. The compatibility of the product is the responsibility of the person who designs the equipment or decides its specifications.

Since the product specified here is used under various operating conditions, its compatibility with specific equipment must be decided by the person who designs the equipment or decides its specifications based on necessary analysis and test results.

The expected performance and safety assurance of the equipment will be the responsibility of the person who has determined its compatibility with the product.

This person should also continuously review all specifications of the product referring to its latest catalog information, with a view to giving due consideration to any possibility of equipment failure when configuring the equipment.

### 2. Only personnel with appropriate training should operate machinery and equipment.

The product specified here may become unsafe if handled incorrectly.

The assembly, operation and maintenance of machines or equipment including our products must be performed by an operator who is appropriately trained and experienced.

### 3. Do not service or attempt to remove product and machinery/equipment until safety is confirmed.

1. The inspection and maintenance of machinery/equipment should only be performed after measures to prevent falling or runaway of the driven objects have been confirmed.

2. When the product is to be removed, confirm that the safety measures as mentioned above are implemented and the power from any appropriate source is cut, and read and understand the specific product precautions of all relevant products carefully.

3. Before machinery/equipment is restarted, take measures to prevent unexpected operation and malfunction.

### 4. Our products cannot be used beyond their specifications. Our products are not developed, designed, and manufactured to be used under the following conditions or environments. Use under such conditions or environments is not covered.

1. Conditions and environments outside of the given specifications or use outdoors or in a place exposed to direct sunlight.

2. Use for nuclear power, railways, aviation, space equipment, ships, vehicles, military application, equipment affecting human life, body, and property, fuel equipment, entertainment equipment, emergency shut-off circuits, press clutches, brake circuits, safety equipment, etc., and use for applications that do not conform to standard specifications such as catalogs and operation manuals.

3. Use for interlock circuits, except for use with double interlock such as installing a mechanical protection function in case of failure. Please periodically inspect the product to confirm that the product is operating properly.



# Electric Actuator/Slider Type compatible with manifold controller Safety Precautions

## Caution

**We develop, design, and manufacture our products to be used for automatic control equipment, and provide them for peaceful use in manufacturing industries.**

**Use in non-manufacturing business is not covered.**

Products we manufacture and sell cannot be used for the purpose of transactions or certification specified in the Measurement Act.

The new Measurement Act prohibits use of any unit other than SI units in Japan.

## Limited warranty and Disclaimer/Compliance Requirements

The product used is subject to the following “Limited warranty and Disclaimer” and “Compliance Requirements”.

Read and accept them before using the product.

### Limited warranty and Disclaimer

1. The warranty period of the product is 1 year in service or 1.5 years after the product is delivered, whichever is first.\*2)

Also, the product may have specified durability, running distance or replacement parts. Please consult your nearest sales branch.

2. For any failure or damage reported within the warranty period which is clearly our responsibility,

a replacement product or necessary parts will be provided.

This limited warranty applies only to our product independently, and not to any other damage incurred due to the failure of the product.

3. Prior to using SMC products, please read and understand the warranty terms and disclaimers noted in the specified catalog for the particular products.

\*2) Vacuum pads are excluded from this 1 year warranty.

Avacuum pad is a consumable part, so it is warranted for a year after it is delivered.

Also, even within the warranty period, the wear of a product due to the use of the vacuum pad or failure due to the deterioration of rubber material are not covered by the limited warranty.

### Compliance Requirements

1. The use of SMC products with production equipment for the manufacture of weapons of mass destruction (WMD) or any other weapon is strictly prohibited.
2. The exports of SMC products or technology from one country to another are governed by the relevant security laws and regulation of the countries involved in the transaction. Prior to the shipment of a SMC product to another country, assure that all local rules governing that export are known and followed.

## Precautions for product specific

### Precautions for wiring and cable

#### ⚠ Warning

- ① **Installation, adjustment, inspection, or wiring changes should be conducted with the power supply to this product turned OFF.**  
Electrical shock, malfunction, or damage can result.
- ② **Never disassemble the cable.**
- ③ **Never connect or disconnect the cable or connector with the power ON.**

#### ⚠ Caution

- ① **Wire the connector securely.**  
Do not apply any voltage to the terminals other than those specified in the operation manual "Manifold Controller for Electric Actuators/JXD1-M\*".
- ② **Wire the connector correctly.**  
Check for correct connector wiring and polarity.
- ③ **Take appropriate measures against noise.**  
Noise in a signal line may cause malfunction.  
As a countermeasure, high voltage and low voltage cables should be separated, and keep wiring lengths short, etc.
- ④ **Do not connect power or high-voltage cables in the same wiring path as the unit.**  
The product can malfunction due to noise and surge voltage interference in the signal line from power and high-voltage cables. Separate the wiring of the electric actuator and its peripheral device from that of power and high-voltage cables.
- ⑤ **Take care that actuator movement does not damage cables.**
- ⑥ **Operate with cables secured.**  
Avoid bending cables at sharp angles where they enter the electric actuator.
- ⑦ **Avoid twisting, folding, rotating, or applying external force to the cable.**  
Electric shock, wire breakage, contact failure, or a loss of product control may occur.
- ⑧ **Do not move the cables coming out of the actuator.**  
The motor cable and lock cable are not robot cable.  
If they are moved, they may break. Fix the part A in the figure below so that it will not move.

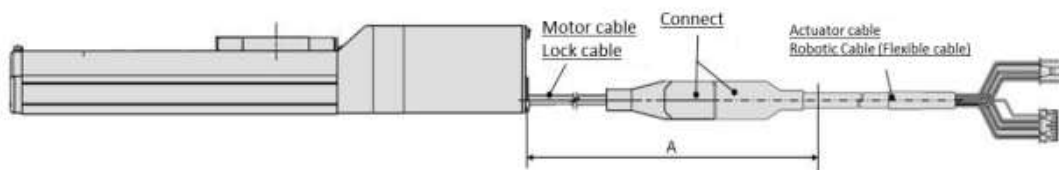

- ⑨ **When the actuator cable is to be bent repeatedly, do not route it in a movable wiring duct smaller than the minimum specified radius (For cable lengths of 10 m or less: bend radius = 56 mm minimum; For cable lengths of 15 m or more: bend radius = 77 mm minimum).**

Repeated use of the cable with a bending radius less than the bending radius may cause electric shock, cable breakage, poor contact, runaway, or other problems.

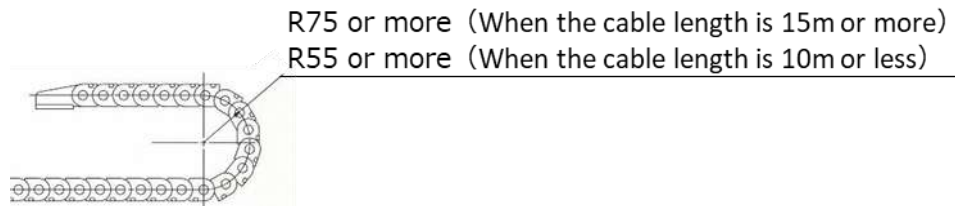

- ⑩ **Confirm wiring insulation.**

Poor insulation (interference with other circuits, poor insulation between terminals etc.) can apply excessive voltage or current to the product causing damage.

- ⑪ **The electric actuator speed and force may change depending on the cable length, load, and mounting conditions.**

Furthermore, if the cable length exceeds 5 m, then it will decrease by up to 10% for every additional 5 m. (If cable length is 15m: Maximum 20% reduction.)

- ⑫ **When checking the conductivity of the cable, be careful not to deform the connector's mating hole and terminals.**

Inserting a non-compatible connector, tool, cylinder-shaped object, etc., into the connector's mating hole can cause the mating hole or terminals to become deformed, which may cause contact failure or disconnection.

- ⑬ **Refrain from plugging in and unplugging the connector frequently.**

Doing so may result in contact failure or disconnection.

- ⑭ **Do not connect wires while the power is ON.**

It may cause the electric actuator or its peripheral devices to be damaged, causing a malfunction.

## 【Transportation】

### ⚠ Caution

- ① **Do not carry or swing the product by the cable or motor.**

## Electric Actuators / Common Precautions

### ■ Design

### ⚠ Warning

- ① **Be sure to read this Operation Manual**

(This manual and "Manifold Controller for Electric Actuators / JXD1-M\*").

Handling or operation other than that specified in this Operation Manual may lead to damage or product failure.

Any damage attributed to the use beyond the specifications is not guaranteed.

- ② **There is a possibility of dangerous sudden action by the product if sliding parts of machinery are twisted due to external forces etc.**

In such cases, human injury may occur, such as by catching hands or feet in the machinery, or damage to the machinery itself may occur. Design the machinery to avoid such dangers.

- ③ **A protective cover is recommended to minimize the risk of personal injury.**

If a driven object and moving parts of the product are in close proximity, personal injury may occur. Design the system to avoid contact with the human body.

**④ Securely tighten all stationary parts and connected parts so that they will not become loose.**

When the product operates with high frequency or is installed where there is a lot of vibration, ensure that all parts remain secure.

**⑤ Consider a possible loss of power source.**

Take measures to prevent injury and equipment damage even in the case of a power source failure.

**⑥ Consider behavior of emergency stop of whole system.**

Design the system so that human injury and/or damage to machinery and equipment will not be caused when it is stopped by a safety device for abnormal conditions such as a power outage or a manual emergency stop of whole system.

**⑦ Consider the action when operation is restarted after an emergency stop or abnormal stop of whole system.**

Design the system so that human injury or equipment damage will not occur upon restart of operation of whole system.

**⑧ Never disassemble or modify (including additional machining) the product.**

An injury or failure can result.

It will cause the loss of the product performance.

**⑨ Do not use the stop signal as the emergency stop of the system.**

Stop by shutdown of M24V is for stopping the electric actuator with deceleration.

For the emergency stop of the equipment, design the system with a separate emergency stop circuit conforming to relevant safety standards.

**⑩ When using the electric actuator for vertical applications, it is necessary to build in a safety device.**

The rod may fall due to the weight of work. The safety device should not interfere with normal operation of the machine.

**⑪ Do not exceed the product specifications even if a work load is supported by external guides.**

Although the Electric actuator moment is reduced by the external guides, the required trans- port ability (the relationship between the speed and the work load) is not reduced.

**⑫ In order to prevent danger and damage due to the breakdown and the malfunction of this product, which may occur at a certain probability, a backup system should be established in advance by giving a multiple-layered structure or a fail-safe design to the equipment, etc.**

**⑬ Avoid designing a system that allows the driving part of an electric actuator to operate with a spring or other external force.**

**⚠ Caution**

**① Operate within the limits of the maximum usable stroke.**

The product will be damaged if it is used with a stroke which exceeds the maximum stroke. Refer to the specifications of the product.

**② When the product repeatedly cycles with partial strokes, operate it at a full stroke at least once every few 10 strokes.**

Otherwise, lubrication can be lost.

**③ Do not use the product in applications where excessive external force or impact force is applied to it.**

The product can be damaged. The components, including the motor, are manufactured to precise tolerances. Even a slight deformation may cause a malfunction or seizure.

**④ Return to origin cannot be performed during a positioning or pushing operation.**

**⑤ Refer to the Auto Switches Precautions (Best Pneumatics No2) if an auto switch is to be built in and used.**

**⑥ Do not exceed the product specifications even if a work load is supported by external guides.**

Although the actuator moment is reduced by external guides, the required transport ability (the relationship between the speed and the work load) is not reduced.

■ **Mounting**

⚠ **Warning**

**① Install and operate the product only after reading this Operation Manual carefully and understanding its contents. Keep the manual in a safe place for future reference.**

**② Observe the tightening torque for screws.**

Tighten the screws to the recommended torque for mounting the product.

**③ Do not make any alterations to this product.**

Alterations made to this product may lead to a loss of durability and damage to the product, which can lead to human injury and damage to other equipment and machinery.

**④ When an external guide is used, connect the moving parts of the product and the load in such a way that there is no interference at any point within the stroke.**

Do not scratch or damage the sliding part by hitting it with an object. Components are manufactured to precise tolerances, so the slightest deformation may cause faulty operation.

**⑤ Prevent the seizure of rotating parts (pins, etc.) by applying grease.**

**⑥ Do not use the product until it is verified that the equipment can operate properly.**

After mounting or repair, connect the power supply to the product and perform appropriate functional inspections to check it is mounted correctly.

**⑦ When one side is fixed**

When an actuator is operated at a high speed with one end fixed and the other free (basic, flange, or direct mount types), a bending moment may act on the actuator due to the vibration generated at the stroke end, which can damage the actuator. In such a case, install a mounting bracket to suppress the vibration of the actuator body, or reduce the speed so that the actuator does not vibrate. Also, use a mounting bracket when moving the actuator body or when a long stroke actuator is mounted horizontally and fixed at one end.

**⑧ When mounting the actuator or attaching the work piece, do not apply strong impact or large moment.**

If an external force above the allowable moment is applied, it may cause looseness in the guide unit, an increase in sliding resistance or other problems.



⑨ **Maintenance space**

Allow sufficient space around the product for maintenance and inspection.

⑩ **The electric actuator and its peripheral devices should be installed on a fire-proof material.**

Direct installation on or near a flammable material may cause a fire.

⑪ **Do not install the product in a place subject to vibrations and impacts.**

It will cause failure or malfunction.

⑫ **Take measures to ensure that the operating temperatures of the electric actuator and its peripheral devices are within the range of the specifications.**

**Also, should be installed with 50mm or larger spaces between each side of it and the other structures or components.**

It may cause a malfunction of the controller and its peripheral devices and a fire.

⑬ **Do not mount the controller and its peripheral devices near a large electromagnetic contactor or no-fuse breaker which generates vibration on the same panel. Mount them on different panels or keep the controller and its peripheral devices away from such a vibration source.**

⑭ **Install the electric actuator and its peripheral devices on a flat surface.**

If the mounting surface is distorted or uneven, an unacceptable force may be added to the housing, etc., causing problems.

■ **Handling**



**Warning**

① **Do not touch the motor while in operation.**

The surface temperature of the motor can increase to approx. 80°C due to operating conditions. Energizing alone may also cause this temperature increase. Do not touch the motor when in operation as it may cause burns.

② **If abnormal heating, smoking, or fire, etc., occurs in the product, immediately turn OFF the power supply.**

③ **Immediately stop operation if abnormal noise or vibration occurs.**

If abnormal operation noise or vibration occurs, the product may have been mounted incorrectly. Unless operation of the product is stopped for inspection, the product can be seriously damaged.

④ **Never touch the rotating part of the motor or moving part of the actuator while in operation.**

⑤ **When installing, adjusting, inspecting or performing maintenance on the product and related equipment, be sure to turn off the power supply to them. Then, lock it so that no one other than the person working can turn the power on, or implement measures such as a safety plug.**

⑥ **The inside of the electric actuator and its connector should not be touched.**

It may cause an electric shock or damage to the controller.

⑦ **Do not perform the operation or setting of the product with wet hands.**

Doing so may cause an electric shock.

- ⑧ **Products with damage or those missing any components should not be used.**  
An electric shock, fire, or injury may result.
- ⑨ **Be careful not to be caught or hit by the workpiece while the electric actuator is moving.**  
It may cause an injury.
- ⑩ **Do not connect the power supply to the product before confirming the area to which the work-piece moves are safe.**  
The movement of the workpiece may cause an accident.
- ⑪ **Before installation, wiring, and maintenance, the voltage should be checked with a tester 5 minutes after the power supply has been turned off.**  
Otherwise, an electric shock, fire, or injury may result.
- ⑫ **Do not use the product in an area where dust, powder, water, chemicals, or oil is in the air.**  
It will cause failure or malfunction.
- ⑬ **Do not use the product in an area where a magnetic field is generated.**  
It will cause failure or malfunction.
- ⑭ **Do not install the product in an environment containing flammable gas, explosive gas, or corrosive gas.**  
It could lead to fire, explosion, and corrosion.
- ⑮ **Radiant heat from strong heat sources, such as a furnace, direct sunlight, etc., should not be applied to the product.**  
It will cause failure of the electric actuator or its peripheral devices.
- ⑯ **Do not use the product in an environment subject to a temperature cycle.**  
It will cause failure of the electric actuator or its peripheral devices.
- ⑰ **Do not use the product in a place where electrical surges are generated.**  
When there are units that generate a large amount of surge around the product (e.g. solenoid type lifters, high-frequency induction furnaces, motors, etc.), this may cause deterioration or damage to the product's internal circuit. Avoid sources of surge generation and crossed lines.
- ⑱ **Do not install the product in an environment under the effect of vibrations and impacts.**  
It will cause failure or malfunction.
- ⑲ **When a surge-generating load, such as a relay or solenoid valve, is driven directly, use a product that incorporates a surge protection device.**
- ⑳ **In the case of an actuator that has a servo motor (24 VDC), the motor phase detection step is conducted by inputting the servo ON signal just after the controller power is turned on. The motor phase detection step moves the table/rod by a distance of one screw-lead maximum.**  
(The motor rotates in the reverse direction if the table/rod hits an obstacle such as an end stop damper). Take the motor phase detection step into consideration when installing and operating this actuator.

## **⚠ Caution**

- ① **Conduct the following inspection before operation.**
  - a) Confirm that the power supply line and each signal line is not damaged.
  - b) No play or looseness of the connectors to each power line and signal line
  - c) No play or looseness of the mounting
  - d) Confirm that the electric actuator/cylinder/controller/driver is operating correctly.
  - e) Confirm the function of the emergency stop of the whole system.
  
- ② **If several persons are to be working concurrently, determine the procedure, signs, measures against abnormality, and restarting measures in advance. Then, have someone else, supervise the work.**
  
- ③ **The product may operate at a speed different from the set speed depending on the load and resistance.**

When selecting a product, check the catalog for instructions regarding selection and specifications.
  
- ④ **Do not apply a load, impact, or resistance in addition to the transferred load during the return to origin.**

If the product is made to return to origin by pushing force, a displacement of the origin position may occur.
  
- ⑤ **Do not remove the product name plate.**
  
- ⑥ **Operation tests should be carried out at a low speed. Start operation using a predefined speed after confirming there are no problems.**
  
- ⑦ **Do not apply forces of impact, collision, or resistance to the moving parts of an actuator during operation.**

Doing so will cause a decrease in product life, damage to the product, etc.

## **【Grounding】**

### **⚠ Warning**

- ① **Ensure that the product is grounded to allow the noise tolerance of the electric actuator.**

Otherwise, it may cause an electric shock or fire.
  
- ② **Dedicated grounding should be used.**

Grounding should be to a D-class ground. (Ground resistance 100Ω or less)
  
- ③ **The earth cable length should be as short as possible.**
  
- ④ **In the unlikely event that malfunction is caused by the ground connection, then it may be disconnected.**
  
- ⑤ **Avoid common grounding points shared with other devices.**

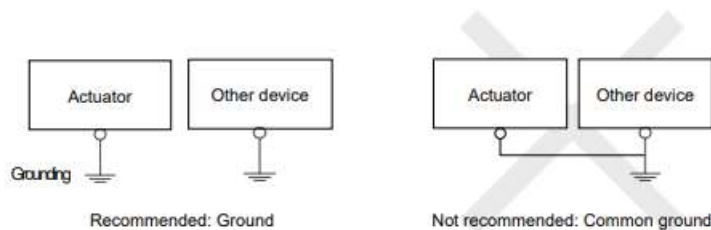

## ■ Power supply

### ⚠ Caution

- ① **Use a power supply that has low noise between lines and between the power and ground.**  
In cases where noise is high, an isolation transformer should be used.
- ② **Use a power supply that has a capacity of not less than the maximum power specified for the electric actuator input power supply.**  
If the power supply capacity is insufficient, voltage drop may occur during acceleration.
- ③ **Appropriate measures should be taken to prevent lightning surges. Ground the surge absorber for lightning separately from the grounding of the electric actuator and its peripheral devices.**

## 【Unpackaging】

### ⚠ Warning

- ① **Check the received product is as ordered.**  
If a different product is installed from the one ordered, injury or damage can result.

## ■ Operating environment

### ⚠ Warning

- ① **Avoid use in the following environments.**
  1. Locations where a large amount of dust and cutting chips are airborne.
  2. Locations where the ambient temperature is outside the range of the temperature specification (refer to specifications)
  3. Locations where the ambient humidity is outside the range of the humidity specification (refer to specifications).
  4. Locations where corrosive gas, flammable gas, sea water, water and steam are present.
  5. Locations where strong magnetic or electric fields are generated.
  6. Locations where direct vibration or impact is applied to the product.
  7. Areas that are exposed to splashes of water and oil drops.
  8. Areas exposed to direct sunlight (ultraviolet rays).
  9. Environment at an altitude of 1000 meters or higher.  
Heat dissipation and withstand voltage will decrease. Contact SMC for details.
- ② **Do not use in an environment where the product is directly exposed to liquid, such as cutting oils.**  
If cutting oils, coolant or oil mist contaminates the product, failure or increased sliding resistance can result.
- ③ **Install a protective cover when the product is used in an environment directly exposed to foreign matter such as dust, cutting chips and spatter.**  
Play or increased sliding resistance can result.
- ④ **Shade the sunlight in the place where the product is applied with direct sunshine.**
- ⑤ **Shield the product if there is a heat source nearby.**  
When there is a heat source surrounding the product, the radiated heat from the heat source can increase the temperature of the product beyond the operating temperature range.
- ⑥ **Grease oil can be reduced due to the external environment and operating conditions. The lubrication performance may deteriorate and shorten the life of the product.**

## **【Storage】**

### **⚠ Warning**

- ① **Do not store the product in a place in direct contact with rain or water drops or is exposed to harmful gas or liquid.**
- ② **Store in an area that is shaded from direct sunlight and has a temperature and humidity within the specified range (-10°C to 60°C and 35% to 85% no condensation or freezing).**
- ③ **Do not apply vibration or impact to the product during storage.**

## **■ Maintenance**

### **⚠ Warning**

- ① **Do not disassemble or repair the product.**  
Fire or electric shock can result. Contact SMC, in case of disassembly for the maintenance.
- ② **Before modifying or checking the wiring, the voltage should be checked with a tester 5 minutes after the power supply is turned off.**  
Electric shock can result.
- ③ **Install the electric actuator and its peripheral devices on a fire-proof material.**  
Direct installation on or near a flammable material may cause a fire.
- ④ **Do not install the product in a place subject to vibrations and impacts.**  
It will cause failure or malfunction.
- ⑤ **Take measure so that the operating temperature of this electric actuator and its peripheral devices are within the range of the specifications. Also, this electric actuator should be installed with 50mm or more between each side of it and other structures or components.**  
It may cause a malfunction of the controller and its peripheral devices or a fire.
- ⑥ **Do not mount the electric actuator and its peripheral devices near a large electromagnetic contactor or no-fuse breaker which generates vibration on the same panel. Mount them on different panels or keep the electric actuator and its peripheral devices away from such a vibration source.**
- ⑦ **Install the electric actuator and its peripheral devices on a flat surface.**  
If the mounting surface is distorted or uneven, an unacceptable force may be added to the case, etc., causing problems.

### **⚠ Caution**

- ① **Maintenance should be performed according to the procedure indicated in the Operation Manual.**  
Incorrect handling can cause an injury, damage or malfunction of equipment and machinery.
- ② **Removal of product**  
When equipment is serviced, first confirm that measures are in place to prevent dropping of work pieces and run-away of equipment, etc., and then cut the power supply to the system. When machinery is restarted, check that operation is normal with actuators in the proper positions.

- ③ **Do not operate using external forces while the electric actuator and controller are connected.**

If the electric actuator mover is intentionally moved by external force (e.g. spring, human power, etc.), primary side of the controller input power supply must be cut off before doing that.

If the slider is moved while the electric actuator is connected to the controller, the motor induced voltage will be passed around the controller. Therefore, if the actuator is moved at high speed and frequency, this induced voltage may cause the controller to break down.

## **【Lubrication】**

### **⚠ Caution**

- ① **The product has been lubricated for life at manufacture and does not require lubrication in service.**

Contact SMC if lubrication will be applied.

## **■ Precautions for actuator with lock**

### **⚠ Warning**

- ① **Do not use the lock as a safety lock or a control that requires a locking force.**

The lock used for the product with a lock is designed to prevent dropping of the work piece.

- ② **When using in a mounting position other than horizontal, be sure to use an electric actuator with a lock.**

If the product is not equipped with a lock, the product will move and drop the work piece when the power is removed.

- ③ **"Measures against drops" means preventing a work piece from dropping due to its weight when the product operation is stopped and the power supply is turned off.**

- ④ **Do not apply an impact load or strong vibration while the lock is activated.**

If an external impact load or strong vibration is applied to the product, the lock will lose its holding force and damage to the sliding part of the lock or reduced lifetime can result. The same situations will occur when the lock slips due to a force higher than its holding force, as this will accelerate the wear to the lock.

- ⑤ **Do not apply liquid or oil and grease to the lock or its surrounding.**

When liquid or oil and grease are adhered to the sliding part of the lock, its holding force will reduce significantly. Or, lock sliding part performance and condition changes may cause a lock release malfunction.

- ⑥ **Take measures against drops and check that safety is assured before mounting, adjustment and inspection of the product.**

If the lock is released with the product mounted vertically, a work piece can drop due to its weight.

- ⑦ **If the mover of electric actuator with lock is intentionally moved by external force (e.g. spring, human power, etc.), supply 24 V DC of the lock release power supply to the LKRLS1 and LKRLS2 terminals of the power supply blocking plug after the controller input power supply primary side is shut off.**

If the product is manually operated without releasing the lock, wearing of the lock sliding surface will be increased, causing reduction in the holding force and the life of the locking mechanism.

- ⑧ **Do not constantly energize LKRLS1 and LKRLS2.**

The LKRLS1 and LKRLS2 are only used for adjustment and emergency return. Be sure to stop supplying 24 VDC power to LKRLS1 and LKRLS2 during normal operation. If power is still supplied to LKRLS1 and LKRLS2, the lock is forcibly released. Therefore, the workpiece may fall under its own weight when the servo is turned off, which may result in equipment failure.

- ⑨ **The actuator may be unable to unlock when the lock sliding part reaches its end of life, due to the rotation sliding during operation. When the lock mechanism reaches its life, contact SMC sales office for replacement parts.**

The sliding part for locking may make noise during operation, but this is normal.

## Electric actuators / Slider type – Common precautions

### ■ Design / Selection

#### ⚠ Caution

- ① **Do not apply a load in excess of the actuator specification.**

A product should be selected based on the maximum work load and allowable moment.

If the product is used outside of the operating specification, eccentric load applied to the guide will become excessive and have adverse effects such as creating play in the guide, reduced accuracy and reduced product life.

- ② **Do not exceed the speed limit of the specification.**

Select a suitable actuator by the relationship of allowable work load and speed. Noise or reduction of accuracy may occur if the actuator is operated in excess of its specification.

This could lead to reduced accuracy and reduced product life.

- ③ **Do not use the product in applications where excessive external force or impact force is applied.**

This can lead to premature failure of the product.

- ④ **When the product repeatedly cycles with partial strokes (see the table below), operate it at a full stroke at least once every few 10 strokes.**

Otherwise, lubrication can run out.

Model	Partial stroke
LE2FS 16	50mm or less
LE2FS 25	65mm or less
LE2FS 32	70mm or less
LE2FS 40	105mm or less

- ⑤ **Actuator sizing is necessary with the total work load including the external force if external force is added on the actuator table.**

When mounting cable-duct to actuator, the resistance of actuator table may increase. It causes an overload alarm, so pay attention to the resistance.

### ■ Handling

#### ⚠ Caution

- ① **INP Output Signal**

1) Positioning operation

The INP output signal turns ON when the actuator position is within the range set by the parameter **【Positioning Width】** relative to the target position.

Default value: Set at **【0.50】** or more. This may cause a malfunction.

- ② **When pushing operation, be sure to use in "pushing operation". Do not hit the work piece in positioning operation or in the range of positioning operation.**  
It may lead a malfunction.

- ③ **Keep the specifications driving speed range for pushing operation.**  
This may lead to damage and malfunction.

**④ Do not cause a collision at the stroke end, except for return to origin.**

The table may collide with the stroke end of the actuator during operation if it is used outside of the specification range, or if incorrect input instructions are given, such as operation instructions outside the actual stroke due to changes in the controller/driver settings or origin position. Please check thoroughly before use. If the table collides with the stroke end, the guide, belt, internal stopper, etc. may be damaged, resulting in malfunction.

Also, be careful that the work piece may drop when it is vertical.



**⑤ Do not change the positioning force from the default setting.**

It may cause performance degradation and alarms.

**⑥ Do not operate by fixing the table and moving the actuator body.**

An excessive load will be applied to the table, which could lead to damage to the actuator and reduced accuracy and reduced product life.

**⑦ Check the specification for the minimum speed of the actuator.**

**Operation outside the specifications may cause malfunctions such as knocking.**

**⑧ The actual speed of this actuator is affected by the work load and stroke.**

Check the model selection section of the catalog.

**⑨ In pushing operation, set the product to a position of at least 2mm away from a work piece.**

**(This position is referred to as a pushing start position.)**

If the product is set to the same position as a work piece, the following alarm and unstable operation can occur.

- a. "Posn failed" alarm

The product cannot reach a pushing start position due to the deviation of work pieces in width.

**⑩ Do not apply a load or impact or resistance in addition to the operation during a return to origin.**

Otherwise, the origin can be displaced since it is based on the detected motor torque.

**⑪ Do not dent, scratch, or cause other damage to the body and table mounting surfaces.**

Damage can cause reduction in flatness, play in the guide and an increase in sliding resistance.

**⑫ Do not hit the table with the workpiece in the positioning operation and positioning range.**

**⑬ There is a type where grease is applied to the dust seal band for sliding. When wiping off the grease remove foreign matter, etc..., be sure to apply grease again.**

**⑭ For bottom mounting, the dust seal band may be deflected., be sure to apply grease again.**



⑮ Operate within the following ranges of the duty ratio when pushing operation.

The duty ratio is a ratio at the time that can keep being pushed.

Model	Ambient temperature [°C]	Pushing force [%]	Duty ratio [%]	Continuous Pushing force time [min]
LE2FS16	40 or less	25 to 45	100	-
LE2FS25	40 or less	25 to 50	100	-
LE2FS32	40 or less	30 to 70	100	-
LE2FS40	40 or less	30 to 70	100	-

■ Mounting

⚠ Caution

- ① Design the installation so that the temperature surrounding the actuator is 40°C or less.
- ② Keep the flatness of mounting surface to within [0.1mm or less for a length of 500mm].  
Insufficient flatness of the work piece or the surface onto which the actuator body is to be mounted can cause play in the guides and increased sliding resistance.
- ③ When mounting the workpiece or other device to the actuator tighten the fixing screws with adequate torque for work piece within the Maximum tightening torque.  
Tightening the screws with a higher torque than the maximum may cause malfunction, whilst tightening with a lower torque can cause the displacement of the mounting position or in extreme conditions detaching of the work piece.

Work piece fixed

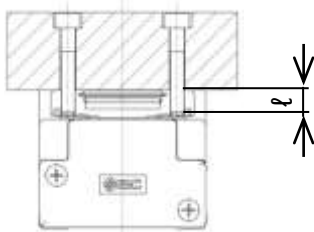

Model	Bolt used	Tightening [N·m]	l Maximum thread depth [mm]
LE2FS16	M4x0.7	1.5±10%	6
LE2FS25	M5x0.8	3.0±10%	8
LE2FS32	M6x1	5.2±10%	9
LE2FS40	M8x1.25	12.5±10%	13

Use screws with adequate length, but with a length less than the maximum thread depth.  
The use of screws which are too long can touch the body and cause malfunction.  
(Approximate screw length: 0.5 mm or more shorter than the maximum thread depth)

- ④ When mounting the product, use screws of adequate length and tighten them to the required torque. Also, use all mounting holes to achieve the product specification.

Tightening the screws with a higher torque than the maximum may cause malfunction, whilst tightening with a lower torque can cause the displacement of the mounting position or in extreme conditions detaching of the work piece.

Actuator mounting

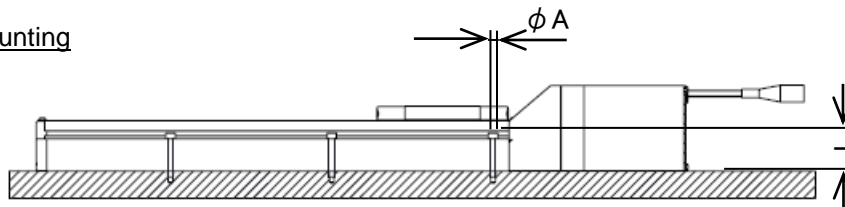

Model	Bolt used	Tightening [N·m]	φA [mm]	L [mm]
LE2FS16	M3	0.63±10%	3.5	23.5
LE2FS25	M4	1.5±10%	4.5	24
LE2FS32	M5	3.0±10%	5.5	30
LE2FS40	M6	5.2±10%	6.6	31

## Body mounting example

### For bottom of housing B

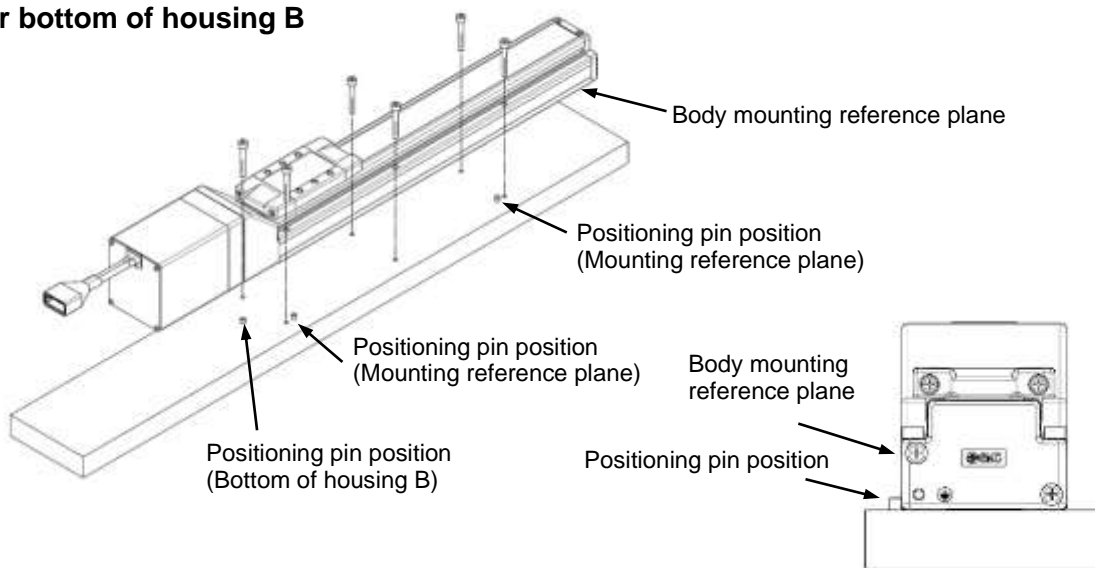

Body mounting reference plane is the datum level for running parallelism.

If the running parallelism of the table is required, install it by pressing the datum level against parallel pins or similar.

### For the bottom of the body

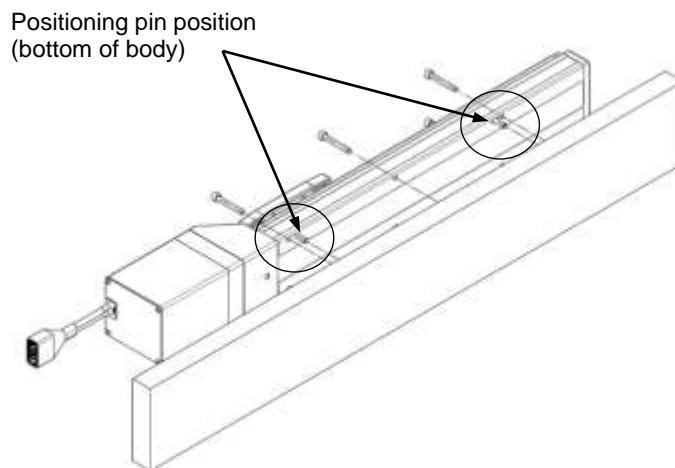

- ⑤ When installing the main unit, ensure that the cable can bend to the specified radius (cable length 10 m or less: 40mm minimum, cable length 15 m or more: 55mm minimum).

### **⚠ Caution**

If the mounting surface of the electric actuator is distorted or not flat, excessive force may be applied to the housing, etc. causing malfunction.

Mount this product on a plane surface.

■ **Maintenance**

⚠ **Caution**

① **Turn OFF the power supply during maintenance and replacement of the product.**

**【 Maintenance frequency 】**

Perform maintenance according to the table below. Please contact SMC if there are any problems.

Frequency	Appearance check	Internal check	Belt check
Inspect daily before operating	○	-	-
Inspection every six months / 1000km / 5million cycle*	○	○	○

\*Select the inspection interval which occurs first.

**【 Items for visual appearance check 】**

1. Loose set screws, abnormal dirt.
2. Check of flaw and cable joint
3. Vibration, noise

**【 Items for internal check 】**

1. Lubricant condition on moving parts.
2. Loose or mechanical play in fixed parts or fixing screws.

**【 Items for belt check 】**

Stop operation immediately and contact SMC when the belt appears to be like the photographs shown below.

**a. Tooth shape canvas is worn out**

Canvas fiber becomes fuzzy. Rubber is removed and the fiber becomes white in color. Lines of fibers become unclear.



Teeth become fuzzy

**b. Peeling off or wearing of the side of the belt**

Belt corner becomes round, and frayed threads sticks out.



Bottom portion of belt gear worn-out (frayed thread exposed )

**c. Belt partially cut**

Belt is partially cut. Foreign matter caught in teeth other than cut part causes flaw.

**d. Vertical line of belt teeth**

Flaw which is made when the belt runs on the flange.

**e. Rubber back of the belt is softened and sticky**

**f. Crack on the back of the belt**



■ **How to detach and attach the dust seal band**

For the internal check as the maintenance, the method of detaching and attaching the dust seal band is shown as the following.

**【Dis-assembly】**

① **Loosen the fixing bolts of end side of the “Band holder”.** (The picture shows LEFB, but LEFS is same instruction as LEFB.)

Pay attention to not cut hand on the edges of the “Dust seal band”. The "Dust seal band" can only be removed by loosening the "Band holder" screws.

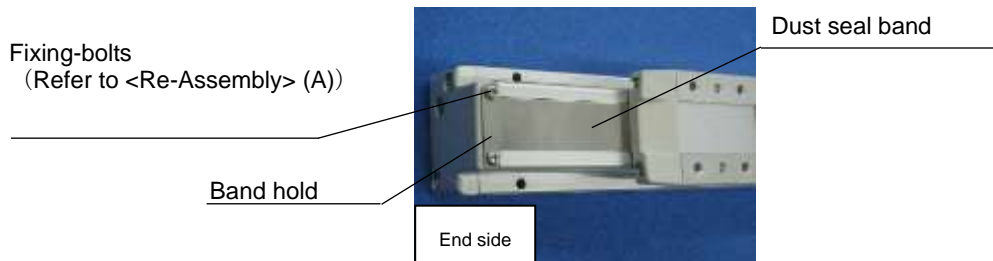

② **Remove the “Seal band holder” and the “plate” as shown.**

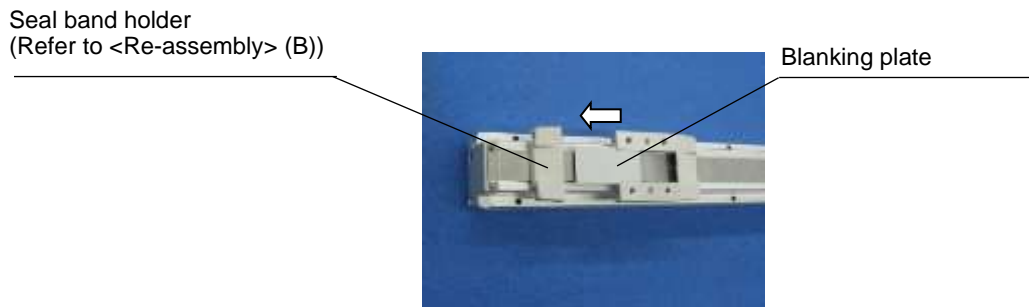

③ **Loosen the fixing screws of the motor side of the “Band holder” and then remove the “Dust seal band”.**

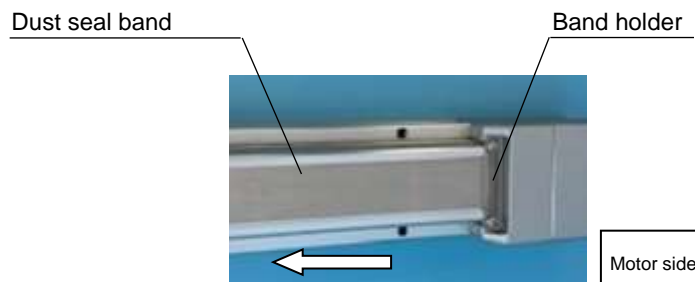

**【Mounting】**

**【Dis-assembly】**The re-assembly is completed by the reverse procedure of “Dis-assembly” sections ①, ② and ③.

(A)

Model	Type of screw	Screw size	Tightening [Nm]
LE2FS16	Round head combination screw	M2.5x5	0.63±10%
LE2FS25		M3x6	
LE2FS32		M3x6	
LE2FS40		M3x6	

(B)

Model	Type of screw	Screw size	Tightening [Nm]
LE2FS16	Cross recessed round head screw	M2.5x12	0.36±10%
LE2FS25		M3x20	0.63±10%
LE2FS32		M4x30	0.76±10%
LE2FS40		M4x35	

## ■ Replacement of belt

- ① After screws are removed, the "Pulley plate" and "Motor cover" are removed.

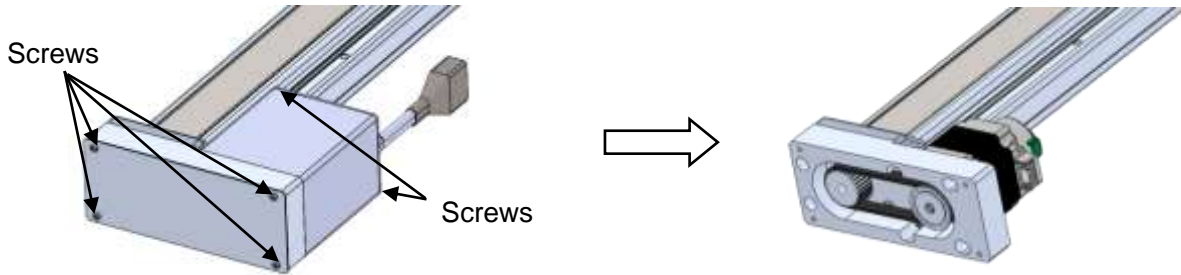

- ② The motor fixing screws are loosened (To extent in which the slide can be done), the "Bearing support" is removed, and the "Belt" is removed.

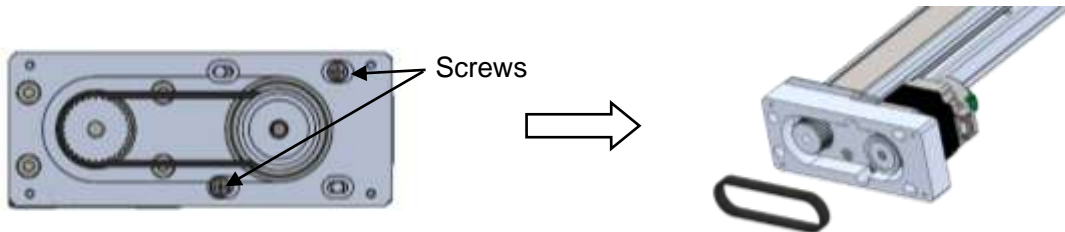

- ③ After the "Belt" is installed, and the bearing support is secured, the root of the "Motor" should be pulled using a string or a long band. With the tensile force adjusted, tighten the screws which fix the actuator to the motor (Refer to the table below) .

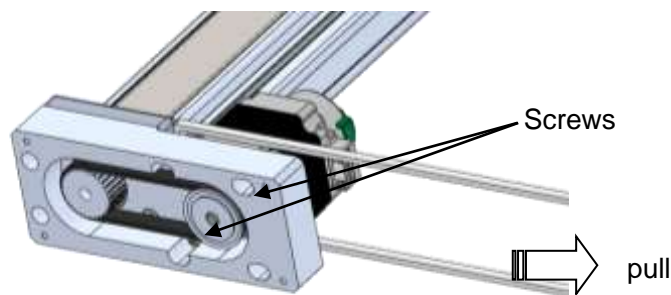

Model	Belt Part number	Pull tension [N]
LE2FS16	LE-D-6-5	9.8
LE2FS25	LE-D-15-1	19.6
LE2FS32	LE-D-19-1	49.0
LE2FS40	LE-D-19-2	70.0

Model	Screw size	Tightening [Nm]
LE2FS16	M3	0.63±10%
LE2FS25		
LE2FS32	M4	1.5±10%
LE2FS40		

- ④ "Pulley plate" and "Motor cover" installation (Refer to the table below).

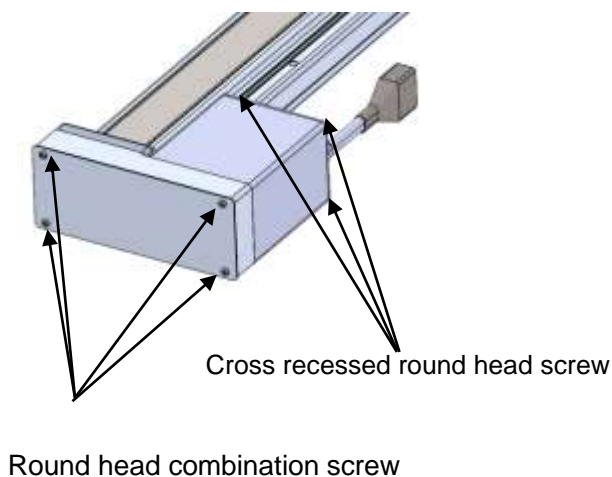

Model	Type of screw	Screw size	Tightening [Nm]
LE2FS16	Round head combination screw	M2.5	0.36±10%
LE2FS25		M3	0.63±10%
LE2FS32			
LE2FS40			

Model	Type of screw	Screw size	Tightening [Nm]
LE2FS16	Cross recessed round head screw	M3	0.32±10%
LE2FS25			
LE2FS32		M4	0.75±10%
LE2FS40			

## Specific precautions for Battery-less absolute encode

### ⚠ Warning

① **Do not use in an environment where strong magnetic fields are present.**

A magnetic sensor is used in the encoder.

Therefore, if the actuator motor is used in a strong magnetic field environment, malfunction or failure may occur.

The major failure is described below.

- Reduction of transporting ability (pushing force, speed)
- Damage to the actuator due to collision to the workpiece by positional displacement occurred.

Do not expose the actuator motor to a magnetic field with a magnetic flux density of 13 mT or more.

#### (Example 1)

When installing an air cylinder with an auto switch (ex. CDQ2 series) side by side, maintain 40 mm minimum around the motor.

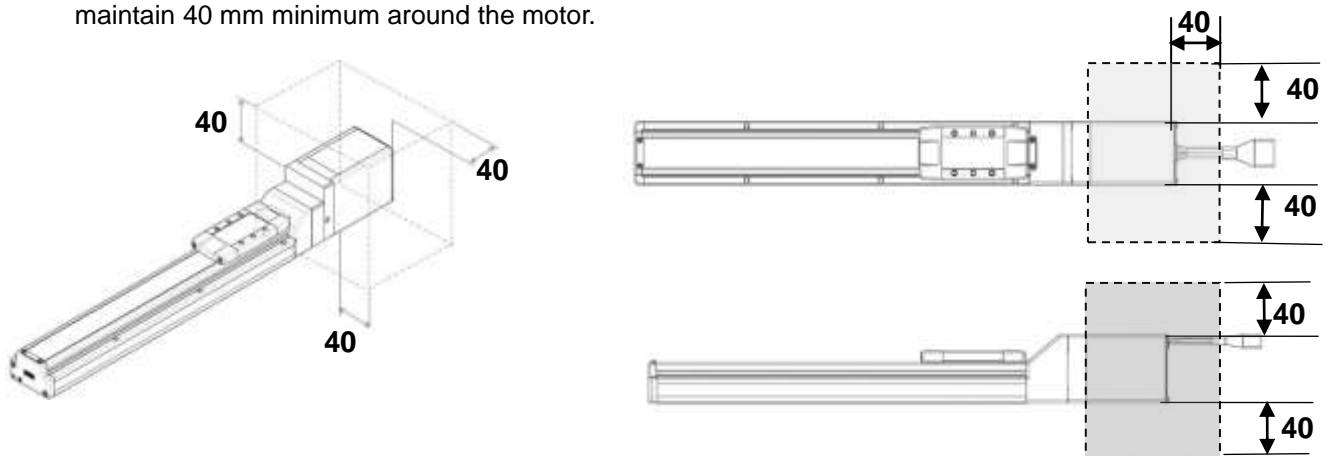

Air cylinder installation with an auto switch is forbidden in the shaded area.

#### (Example 2)

When installing electric actuator LEY(G) or LEF, EQF, EQY, LE2F, LE2Y series with an auto switch by side, leave a gap of 40 mm or more with respect to the position where the magnet passes.

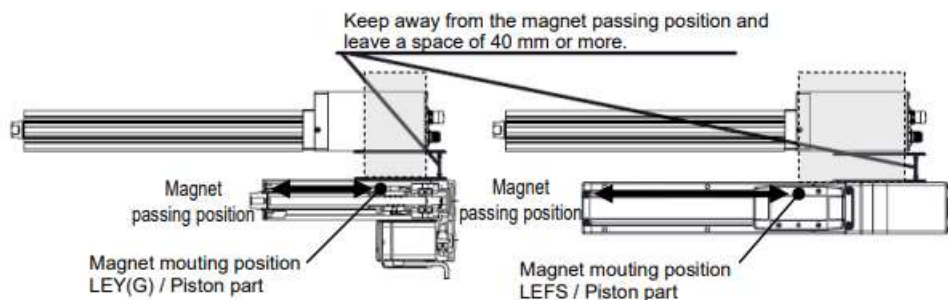

(Example 3)

Multiple actuators can be placed close to each other as shown in the figure below, as long as magnets are not close to the motor section.

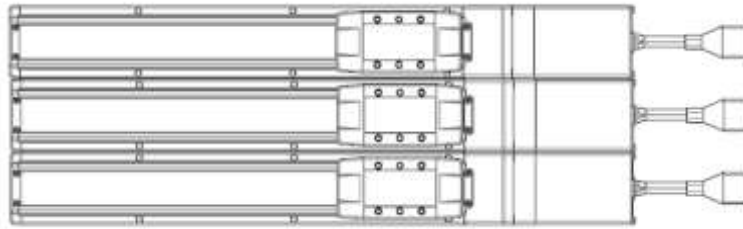

**⚠ Caution**

**① Supply power when the actuator is stationary.**

The electric actuator acquires the absolute position data from the absolute encoder when power is applied.

Therefore, if the power is applied to the electric actuator when the actuator is moving with an external force, the controller fails to acquire the absolute position data, which generates an alarm.

# 1 Outlines of Product

## 1.1 System configuration example

See below for an example of a system configuration using the controller.

**Operation Manual "Manifold Controller for Electric Actuators / JXD1-M\*"**

### 2.2 Product Configuration

## 1.2 Features

Features of the electric actuator.

- Maximum of 16 axes can be connected

In the case of the manifold controller, a maximum of 16 actuator axes can be controlled by connecting driver units.

- Automatic Parameter Discrimination

Parameters are automatically determined when an actuator is connected.

This reduces setup and maintenance time.

- Selectable Operation Mode

Operation mode can be selected as required by I/O control, numerical control, etc.

- Actuator Control

Servo motor control enables a positioning operation and speed and thrust-specified operation of the actuator.

- Thrust-specified operation

The gripping force and pushing force of the electric actuator can be controlled.

- Selectable motor cable entry direction

The motor cable entry direction (axial, right, left, up, or down) can be selected.

### **Caution**

When the device is set up or failure occurs, please refer to the operation manual of software as well as this operation manual.

Keep this operation manual accessible for reference when necessary.



# 1.3 How to Order

How to order is shown below.

L E 2 F S 25 R 1 H A - 300 A G

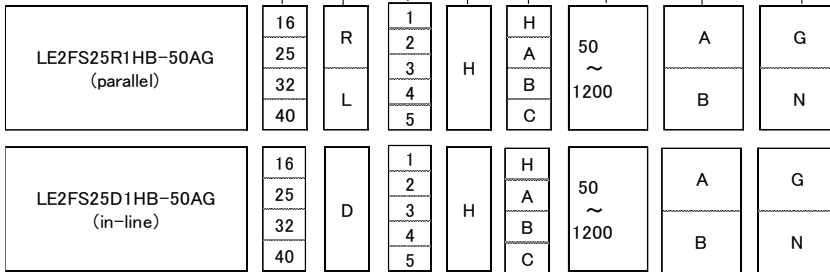
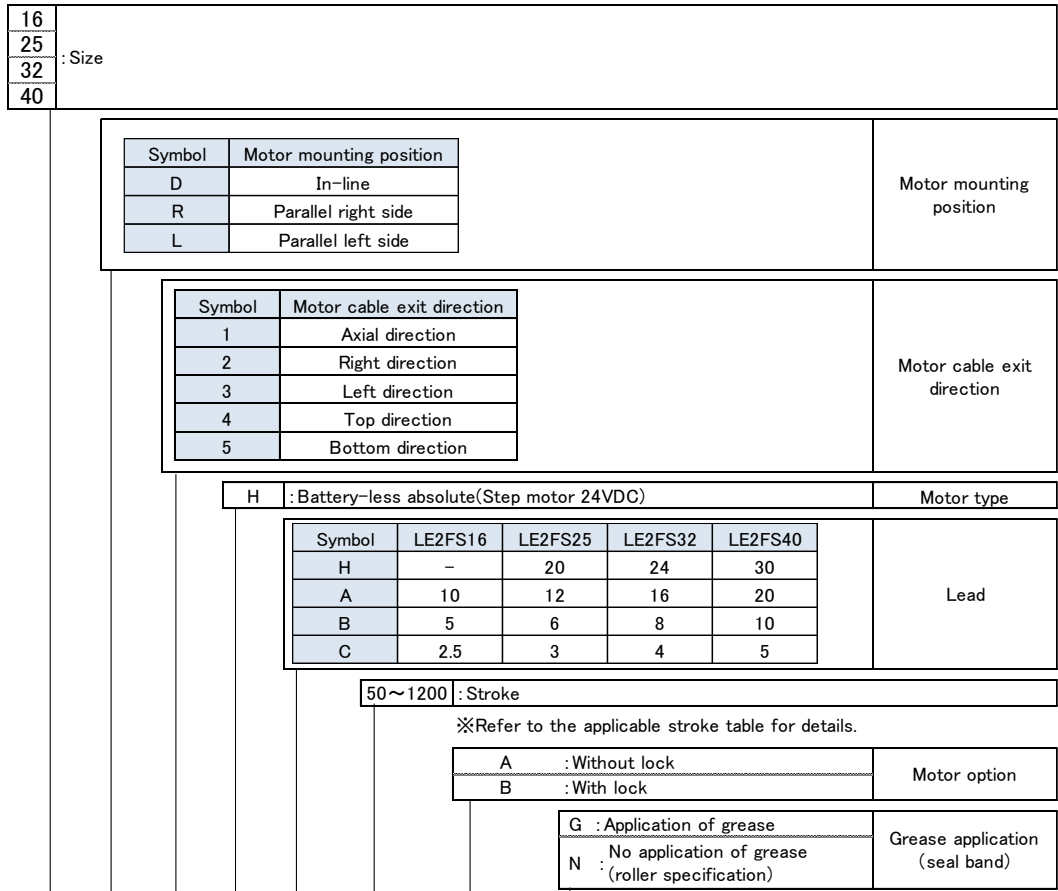

**Applicable stroke table**

Size	Stroke[mm]																						
	50	100	150	200	250	300	350	400	450	500	550	600	650	700	750	800	850	900	950	1000	1100	1200	
16	●	●	●	●	●	●	●	●	●	●	-	-	-	-	-	-	-	-	-	-	-	-	
25	●	●	●	●	●	●	●	●	●	●	●	●	●	●	●	●	-	-	-	-	-	-	
32	●	●	●	●	●	●	●	●	●	●	●	●	●	●	●	●	●	●	●	●	●	-	-
40	-	-	●	●	●	●	●	●	●	●	●	●	●	●	●	●	●	●	●	●	●	●	●

## 1.4 Specifications

### Battery-less absolute encoder type (Step motor 24 VDC)

Model		LE2FS16			LE2FS25					
Actuator specification	Stroke [mm] Note.1)	50 to 500			50 to 800					
	Work load [kg] Note.2)	Horizontal	10	15	18	15	26	40	40	
		Vertical	3	6	12	2	6	12.5	15	
	Pushing force[N] Note.3),4),5)		23 to 41	44 to 80	86 to 154	41 to 81	67 to 135	132 to 265	255 to 511	
	Speed[mm/s]	Stroke Range	to 400	10 to 800	5 to 400	3 to 195	20 to 1200	12 to 850	6 to 450	3 to 225
			401 to 450	10 to 700	5 to 360	3 to 170	20 to 1100	12 to 750	6 to 400	3 to 225
			451 to 500	10 to 600	5 to 300	3 to 140	20 to 1100	12 to 750	6 to 400	3 to 225
			501 to 600	-	-	-	20 to 900	12 to 540	6 to 270	3 to 135
			601 to 700	-	-	-	20 to 630	12 to 420	6 to 230	3 to 115
	701 to 800	-	-	-	20 to 550	12 to 330	6 to 180	3 to 90		
	Max acceleration/deceleration speed[mm/s <sup>2</sup> ]	Horizontal	10000							
		Vertical	5000							
	Pushing speed [mm/s] Note.6)		1 to 50			1 to 35				
	Positioning repeatability [mm]		±0.02	±0.015		±0.02	±0.015			
	Lost motion [mm] Note.7)		0.1 or less							
	Lead [mm]		10	5	2.5	20	12	6	3	
Impact/Vibration resistance [m/s <sup>2</sup> ] Note.8)		50/20								
Actuation type		Ball screw (LE2FS□) , Ball screw and belt (LE2FS□R/L)								
Guide type		Linear Guide								
Operating temperature [°C]		5 to 40								
Operating humidity [%RH]		90 or less (No condensation)								
Electric specification	Motor size	□28			□42					
	Motor type	Battery-less Absolute(Step motor 24VDC)								
	Encoder	Battery-less Absolute								
	Powre supply voltage [V]	24VDC±10%								
	Power [W] Note.9),11)	Max. 58			Max. 72					
Lock unit specifications	Type Note.10)	Non-magnetizing lock								
	Holding force [N]	29	59	118	20	59	123	147		
	Power [W] Note.11)	4			8					
	Powre supply voltage [V]	24VDC±10%								

Note.1) Non-standard strokes are available as special orders, so please contact SMC .

Note.2) Maximum payload at acceleration/deceleration of 3000mm/s<sup>2</sup>.

Work load varies depending on the velocity and acceleration. Please refer to the catalog for the "speed - payload graph".

Furthermore, if the cable length exceeds 5 m, then it will decrease by up to 10% for each 5 m.

Note.3) Pushing force accuracy is ±20% (F.S.).

Note.4) The setting range for the "Pushing force" is from 25% to 45%(LE2FS16) and 25% to 50%(LE2FS25) and 30% to 70%(LE2FS32) and 30% to 70%(LE2FS40).

The pushing force setting range varies depending on the duty ratio and pushing speed. Please refer to the catalog for the "Thrust Conversion Graph"

Note.5) Speed and thrust may vary depending on cable length, load, installation conditions, etc. If the cable length exceeds 5m, the speed/thrust will decrease by up to 10% for every 5m. (For 15m: Max. 20% reduction)

Note.6) When transporting and pushing a workpiece, operate the actuator with the "Horizontal load capacity" or less.

Note.7) Reference value for correcting an error in reciprocal operation.

Note.8) Impact resistance: In a drop impact test, no malfunction occurred in the axial direction and perpendicular direction of the feed screw. (value at the initial stage)

Vibration resistance: 45 to 2000 Hz 1 sweep, no malfunction in the axial direction and perpendicular direction of the feed screw. (value at the initial stage)

Note.9) Indicates the maximum power when operating the actuator only.

Note.10) Only applies to actuators supplied with a lock.

Note.11) For the actuator with lock, please add the power consumption for the lock.

Model		LE2FS32				LE2FS40				
Stroke [mm] Note.1)		50 to 1000				150 to 1200				
Work load [kg] Note.2)		Horizontal	39.5	50	68	68	26	60	75	80
		Vertical	4	10	16	20	4.5	4.5	25	40
Pushing force[N] Note.3),4),5)		60 to 140	90 to 209	176 to 411	341 to 796	48 to 112	72 to 167	141 to 329	273 to 637	
Speed[mm/s]	Stroke Range	to 400	24 to 1100	16 to 750	8 to 450	4 to 125	30 to 1200	20 to 1000	10 to 500	5 to 225
		401 to 450	24 to 1100	16 to 750	8 to 450	4 to 125	30 to 1200	20 to 1000	10 to 500	5 to 225
		451 to 500	24 to 1100	16 to 750	8 to 450	4 to 125	30 to 1200	20 to 1000	10 to 500	5 to 225
		501 to 600	24 to 1100	16 to 750	8 to 450	4 to 125	30 to 1200	20 to 1000	10 to 500	5 to 225
		601 to 700	24 to 930	16 to 620	8 to 310	4 to 125	30 to 1200	20 to 900	10 to 440	5 to 220
		701 to 800	24 to 750	16 to 500	8 to 250	4 to 125	30 to 1140	20 to 760	10 to 350	5 to 175
		801 to 900	24 to 610	16 to 410	8 to 200	4 to 100	30 to 930	20 to 620	10 to 280	5 to 140
		901 to 1000	24 to 500	16 to 340	8 to 170	4 to 85	30 to 780	20 to 520	10 to 250	5 to 125
		1001 to 1100	-	-	-	-	30 to 660	20 to 440	10 to 220	5 to 110
1101 to 1200	-	-	-	-	30 to 570	20 to 380	10 to 190	5 to 95		
Max acceleration/deceleration speed[mm/s <sup>2</sup> ]		Horizontal	10000							
		Vertical	5000							
Pushing speed [mm/s] Note.6)		1 to 30				1 to 30				
Positioning repeatability [mm]		±0.02	±0.015			±0.02	±0.015			
Lost motion [mm] Note.7)		0.1 or less								
Lead [mm]		24	16	8	4	30	20	10	5	
Impact/Vibration resistance [m/s <sup>2</sup> ] Note.8)		50/20								
Actuation type		Ball screw(LE2FS□) , Ball screw and belt(LE2FS□R/L)								
Guide type		Linear Guide								
Operating temperature [°C]		5 to 40								
Operating humidity [%RH]		90 or less(No condensation)								
Motor size		□56.4								
Motor type		Battery-less Absolute(Step motor 24VDC)								
Encoder		Battery-less Absolute								
Power supply voltage [V]		24VDC±10%								
Power [W] Note.9),11)		Max. 93				Max. 93				
Type Note.10)		Non-magnetizing lock								
Holding force [N]		39	98	157	196	44	44	245	392	
Power [W] Note.11)		8				8				
Power supply voltage [V]		24VDC±10%								

Note.1) Non-standard strokes are available as special orders, so please contact SMC .

Note.2) Maximum payload at acceleration/deceleration of 3000mm/s<sup>2</sup>.

Work load varies depending on the velocity and acceleration. Please refer to the catalog for the "speed - payload graph".

Furthermore, if the cable length exceeds 5 m, then it will decrease by up to 10% for each 5 m.

Note.3) Pushing force accuracy is ±20% (F.S.).

Note.4) The setting range for the "Pushing force" is from 25% to 45%(LE2FS16) and 25% to 50%(LE2FS25) and 30% to 70%(LE2FS32) and 30% to 70%(LE2FS40).

The pushing force setting range varies depending on the duty ratio and pushing speed. Please refer to the catalog for the "Thrust Conversion Graph"

Note.5) Speed and thrust may vary depending on cable length, load, installation conditions, etc. If the cable length exceeds 5m, the speed/thrust will decrease by up to 10% for every 5m. (For 15m: Max. 20% reduction)

Note.6) When transporting and pushing a workpiece, operate the actuator with the "Horizontal load capacity" or less.

Note.7) Reference value for correcting an error in reciprocal operation.

Note.8) Impact resistance: In a drop impact test, no malfunction occurred in the axial direction and perpendicular direction of the feed screw. (value at the initial stage)

Vibration resistance: 45 to 2000 Hz 1 sweep, no malfunction in the axial direction and perpendicular direction of the feed screw. (value at the initial stage)

Note.9) Indicates the maximum power when operating the actuator only.

Note.10) Only applies to actuators supplied with a lock.

Note.11) For the actuator with lock, please add the power consumption for the lock.

# Weight

Motor mounting position: I-line

Series	LE2FS16									
Stroke[mm]	50	100	150	200	250	300	350	400	450	500
Weight[kg]	0.91	1.00	1.10	1.19	1.28	1.37	1.47	1.56	1.65	1.75
Additional weight with lock[kg]	0.19									

Series	LE2FS25															
Stroke[mm]	50	100	150	200	250	300	350	400	450	500	550	600	650	700	750	800
Weight[kg]	1.55	1.69	1.83	1.97	2.11	2.25	2.39	2.53	2.67	2.81	2.94	3.08	3.22	3.36	3.50	3.64
Additional weight with lock[kg]	0.34															

Series	LE2FS32																			
Stroke[mm]	50	100	150	200	250	300	350	400	450	500	550	600	650	700	750	800	850	900	950	1000
Weight[kg]	2.63	2.84	3.05	3.25	3.46	3.67	3.87	4.08	4.29	4.49	4.70	4.91	5.12	5.32	5.53	5.74	5.95	6.15	6.36	6.57
Additional weight with lock[kg]	0.63																			

Series	LE2FS40																					
Stroke[mm]	150	200	250	300	350	400	450	500	550	600	650	700	750	800	850	900	950	1000	1100	1200		
Weight[kg]	4.11	4.38	4.71	5.09	5.24	5.46	5.78	6.00	6.31	6.54	6.84	7.08	7.37	7.62	7.90	8.17	8.44	8.71	9.25	9.79		
Additional weight with lock[kg]	0.65																					

Motor mounting position: Parallel type

Series	LE2FS16									
Stroke[mm]	50	100	150	200	250	300	350	400	450	500
Weight[kg]	0.86	0.96	1.05	1.14	1.24	1.33	1.42	1.52	1.61	1.70
Additional weight with lock[kg]	0.19									

Series	LE2FS25															
Stroke[mm]	50	100	150	200	250	300	350	400	450	500	550	600	650	700	750	800
Weight[kg]	1.59	1.73	1.87	2.01	2.15	2.29	2.43	2.57	2.70	2.84	2.98	3.12	3.26	3.40	3.54	3.68
Additional weight with lock[kg]	0.33															

Series	LE2FS32																			
Stroke[mm]	50	100	150	200	250	300	350	400	450	500	550	600	650	700	750	800	850	900	950	1000
Weight[kg]	2.70	2.91	3.12	3.33	3.53	3.74	3.95	4.15	4.36	4.57	4.78	4.98	5.19	5.40	5.61	5.81	6.02	6.23	6.43	6.64
Additional weight with lock[kg]	0.64																			

Series	LE2FS40																					
Stroke[mm]	150	200	250	300	350	400	450	500	550	600	650	700	750	800	850	900	950	1000	1100	1200		
Weight[kg]	4.26	4.52	4.86	5.23	5.39	5.61	5.92	6.14	6.45	6.69	6.98	7.23	7.52	7.77	8.05	8.31	8.58	8.85	9.39	9.94		
Additional weight with lock[kg]	0.64																					

## 1.5 Construction

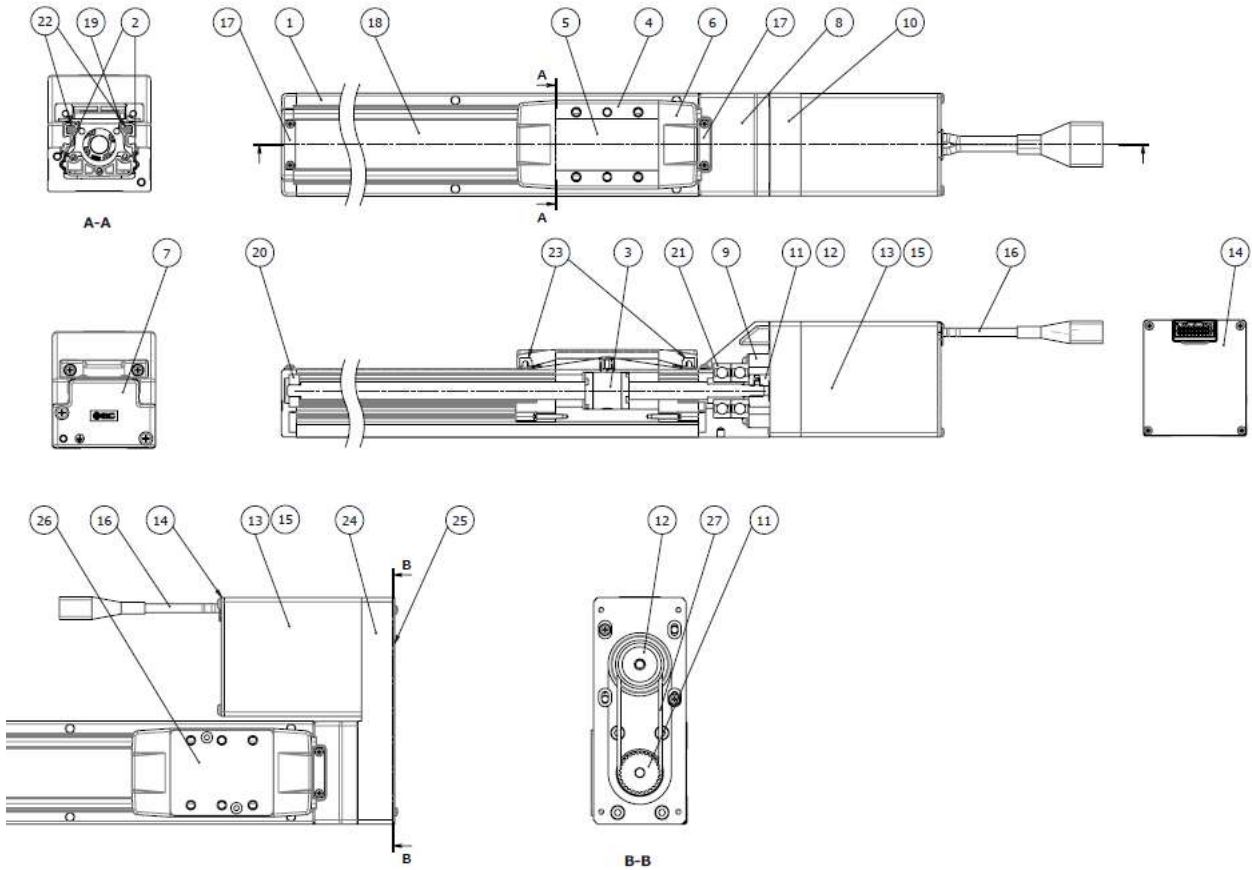

### Component Parts

No.	Description	Material	Remarks
1	Body	Aluminum alloy	Anodized
2	Rail Guide	-	
3	Ball screw assembly	-	
4	Table	Aluminum alloy	Anodized
5	Blanking plate	Aluminum alloy	Anodized
6	Seal band hold down	Synthetic resins	
7	Housing A	Aluminum Die Casting	Coating
8	Housing B	Aluminum Die Casting	Coating
9	Bearing stopper	Aluminum alloy	
10	Motor adapter	Aluminum alloy	Coating
11	Hub/Pulley	Aluminum alloy	
12	Hub/Pulley	Aluminum alloy	

No.	Description	Material	Remarks
13	Motor cover	Aluminum alloy	Anodized
14	End cover	Aluminum alloy	Anodized
15	Motor	-	
16	motor cable	-	
17	Band stopper	Stainless steel	
18	Dust Seal Band	Stainless steel	
19	Seal magnet	-	
20	Bearing	-	For 201 strokes or more
21	Bearing	-	
22	Magnet	-	
23	Roller assembly	Stainless steel	Coating

### Components (parallel motor only)

No.	Description	Material	Remarks
24	Return Plate	Aluminum alloy	Coating
25	Cover plate	Aluminum alloy	Anodized
26	Table spacer	Aluminum alloy	Anodized
27	Belt	-	

### Replacement Parts (parallel motor only)/Belt

No.	Size	Order No.
27	16	LE-D-6-5
	25	LE-D-15-1
	32	LE-D-19-1
	40	LE-D-19-2

### Replacement parts/Grease pack

Applied portion	Order No.
Ball screw	GR-S-010(10G) GR-S-020(20G)
Rail guide	
Dust seal band (When "Without" is selected for the grease application, grease is applied only on the back side.)	

## 1.6 Accessories

### ■ Table spacer (Parallel motor only)

Model	Model	QTY
LE2FS16(L/R)	Table spacer	1
LE2FS25(L/R)		
LE2FS32(L/R)		
LE2FS40(L/R)		

### ■ Optional accessories

- Manifold Controller(JXD1-M※)
  - Actuator cable (JX - CP - D - ※) (P.37 reference)
  - Setup software (ACT-Connected)
- (Please download from SMC website. <http://www.smcworld.com/>)

For details of optional accessories, refer to the Operation Manual

**"Manifold Controller for Electric Actuator / JXD1-M"**,

**2.3 How to display unit part number**

**2.4 Details of options.**

## 2 Installation and Initial Setting

### 2.1 Flow procedure from installation to initial setting

Be sure to check the procedure below before use.

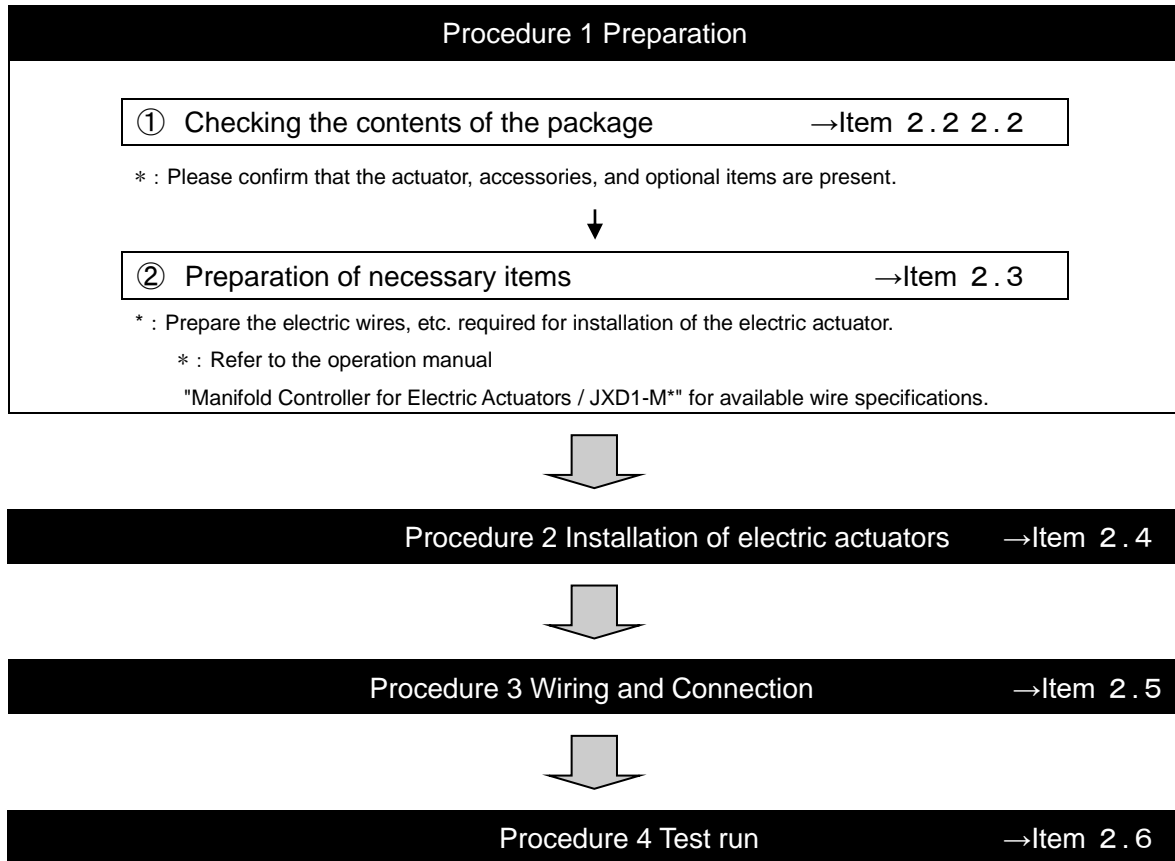

## 2.2 Check the contents of the package

After unpacking everything, check the description on the label to identify the electric actuator and the number of accessories. If any parts are missing or damaged, please contact your distributor.

Product Name and Number	Quantity
Electric actuator (LE2FS□)	1 pcs.
Table spacer *1)	1 pcs.

\*1) Parallel motor only

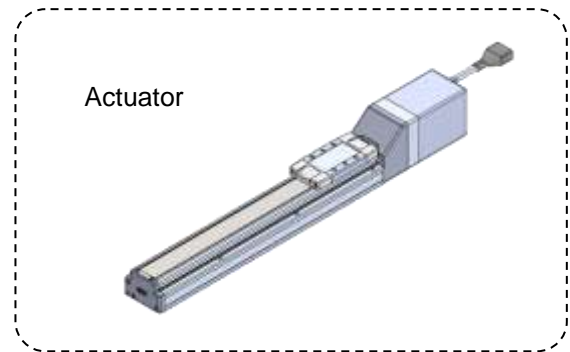

### Optional accessories

- Manifold Controller

For details of the manifold controller, refer to the operation manual.

**"Manifold Controller for Electric Actuator / JXD1-M\*"**

### 2.3 Unit part number display method.

- Actuator cable

For details of the actuator cable, refer to this manual.

### **P37 8.1 Actuator cable**

- Setup software

Please download from SMC website. <http://www.smcworld.com/>

## 2.3 Preparation of necessary supplies

Please prepare the following items for installation and wiring.

- Wiring cables
- M4 screws
- Cable with crimping terminals
- Switch (24 VDC, contact capacity of 0.5 A or more) : For lock release

Please provide the following equipment to run the system.

- 24 VDC power supply
- PC
- USB cable (Type-C cable capable of data communication)
- PLC



## 2.4 Installation of electric actuators

Install the electric actuator at the installation location using the following method.

### (1) Mounting

Refer to Electric actuators / Common precautions in Precautions for product specific for information on screws and tightening torques to be used for mounting workpieces and tools and for mounting the actuator.

### (2) Connection to ground

Install the grounding cable as shown in the figure.

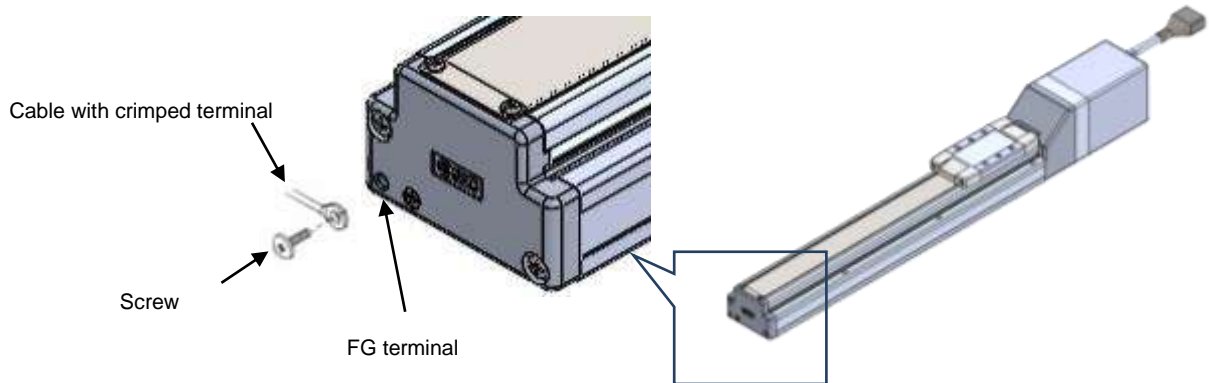

### ⚠ Caution

The screw, cable with crimped terminal and toothed washer must be prepared by the user. The actuator must be connected to Ground to reduce noise. If further noise resistance is required, consider measures such as grounding the 0 V (signal ground). When grounding the 0V, avoid flowing noise from the ground to the 0 V.

### ⚠ Caution

The earth should be a dedicated earth connection. Use a D-class ground connection (ground with a resistance of less than  $100\Omega$ ). The cross-sectional area of the grounding cable shall be  $2\text{mm}^2$  minimum. The Grounding point should be as near as possible to the actuator. Keep the grounding cable as short as possible.

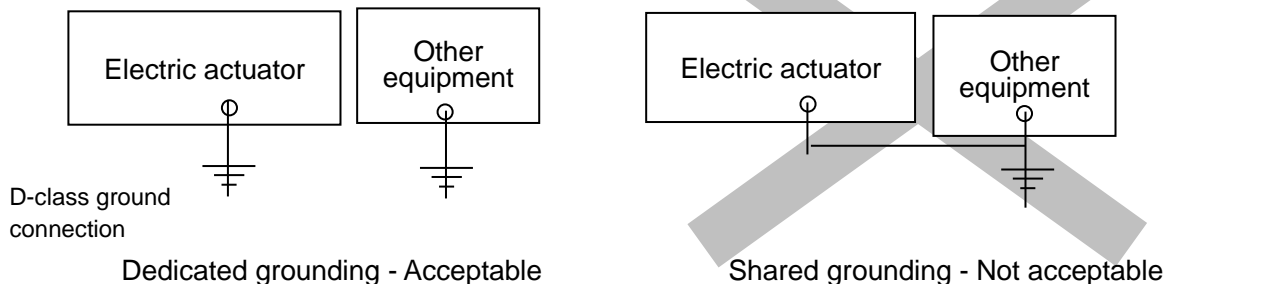

### (3) Precautions for electric actuator compatible with battery-less absolute encoder installation

Please refer to Precautions for product specific of Individual precautions for battery-less absolute encoder.

## 2.5 Wiring and Connection

Prepare the electric actuator LE2FS series and Manifold controller.

Connect the Driver unit of Manifold controller and the electric actuator with the actuator cable.

For wiring details of the manifold controller, please refer to **7. Wiring in the instruction manual "Manifold controller for electric actuator/JXD1-M"**.

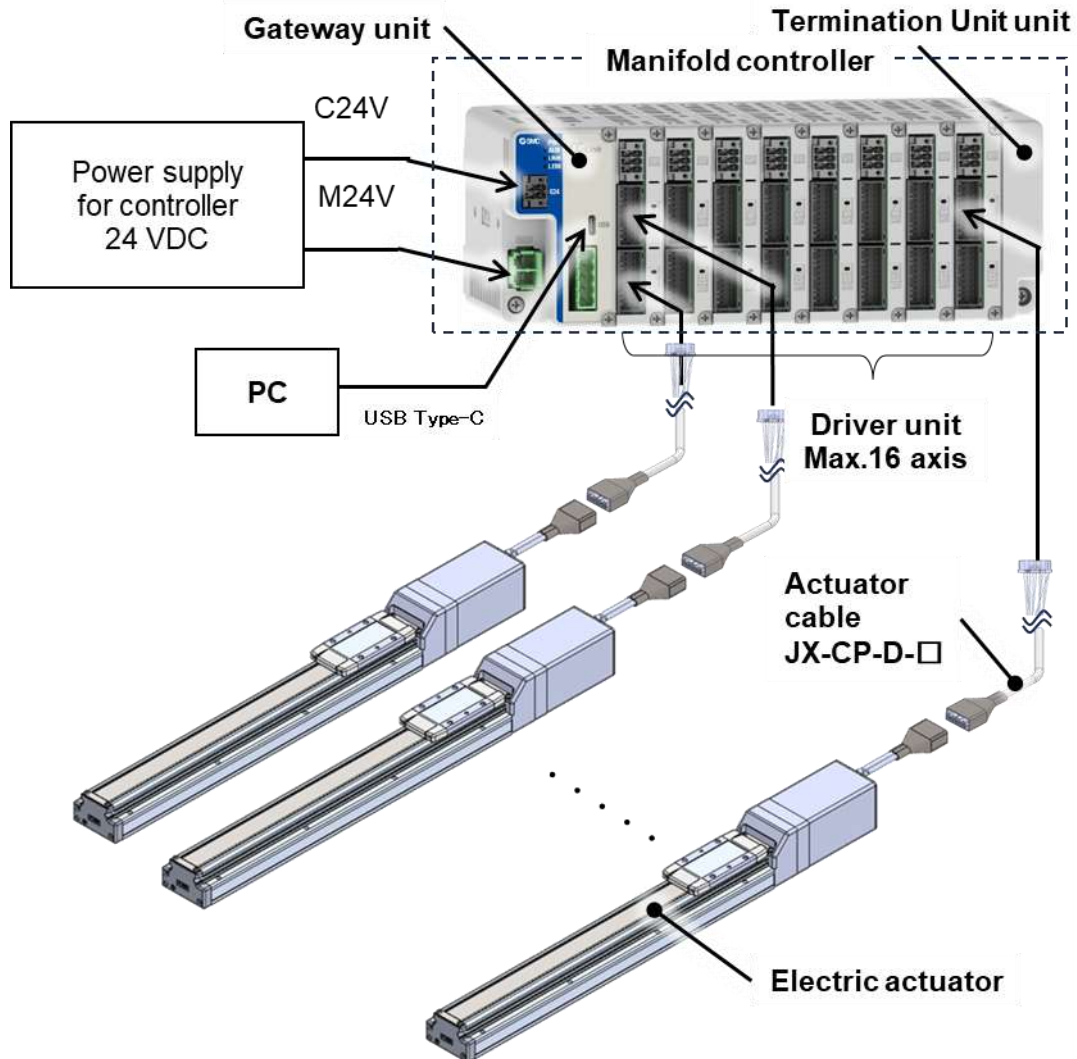

## 2.6 Test run

Perform a test run to ensure that the electric actuator is operating normally in the system.

For information on the operation method of the test run, refer to the following pages of the operation manual "Manifold Controller for Electric Actuators / JXD1-M".

**12.1 Procedure for starting up the power supply.**

**12.2 Operation Procedure for Step Data No. Indicated Operation Function**

## 3 Operation

For each operation procedure and timing chart, refer to the following pages of the operation manual "Manifold Controller for Electric Actuators / JXD1-M".

**12.1 Procedure for starting up the power supply.**

**12.2 Operation Procedure for Step Data No. Indicated Operation Function**

## 4 Operation Guide

For the mechanism of each operation, refer to the following pages of the operation manual "Manifold Controller for Electric Actuators / JXD1-M\*".

**11.1 Return to Origin**

**11.2 Positioning Operation**

**11.3 Pushing Operation**

**11.4 Response Time to Controller Input Signals**

**11.5 Interruption method during operation**

## 5 Alarm

For each alarm detection, its contents, and countermeasures, refer to the following pages of the operation manual "Manifold Controller for Electric Actuators / JXD1-M\*".

**13.1 Alarm Detection in Gateway Units**

**13.2 Alarm Detection for Driver Units**

**13.3 Predictive Maintenance Functions**

## 6 Troubleshooting

For countermeasures in case of operation failure, please refer to the operation manual "Manifold Controller for Electric Actuators / JXD1-M\*", p. 11-12 2.3 Unit Part Number Display Method.

**15. Trouble Shooting**

## 7 Setting

### 7.1 Parameter



Setting of operation condition and other conditions of the electric actuator.

#### **Caution**

Write the parameter when the electric actuator is in the stopped condition.

#### **Details of parameters**

The parameters can be set using the setup software "ACT-Connected".

Write column :  = Effective immediately after writing to the electric actuator,  
 = Effective when the power supply is turned on again.

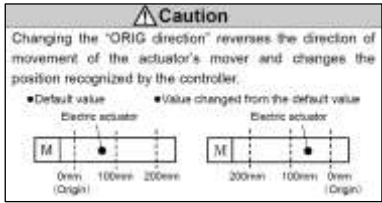
Setting	Lead	Default value				Description	Input range	Load
		LE2FS16	LE2FS25	LE2FS32	LE2FS40			
Stroke(+)	-	Maximum stroke of each product				This defines the positive (+) side limit of the position. (Unit: 0.01mm)	0 to Product stroke(+)	⊙
Stroke(-)	-							
Maximum speed	H	Maximum speed for each product				This defines the maximum limit of the speed. (Unit: 1mm/s)	Input limit value to Maximum speed for each product	⊙
	A							
	B							
	C							
Maximum acceleration/deceleration speed	-	Maximum acceleration /deceleration speed for each product				This defines the deceleration when stopping by the "HOLD" and "RESET" input signals. (Unit: 1mm/s <sup>2</sup> )	1 to 10,000	⊙
Maximum pushing force	-	45	50	70	70	This defines The maximum force for the pushing operation. (Unit: 1%)	1 to 100	⊙
W-AREA1	-	0	0	0	0	This is the setting to define the conditions where the "W-AREA" signal will turn ON. (Unit: 0.01mm)	Basic parameter "Stroke (-)" - "Stroke (+)"	⊙
W-AREA2	-	0	0	0	0	If the current position is within the range between the W-AREA1 and W-AREA2, "WAREA" will turn ON.	Basic parameter "Stroke (-)" - "Stroke (+)"	⊙
Standard pushing speed	-	1	1	1	1	This defines the speed of pushing operation used in "Direct numerical setting mode". (Unit: 1mm/s)	Input limit value to Maximum speed for each product	⊙
Reference positioning torque	-	100	100	100	100	Specifies the positioning torque used in "Direct numerical setting mode". (Unit: 1mm/s)	0 to 100	⊙
Lower speed limit	-	1	1	1	1	Sets the lower limit of the set speed. (Unit: 1mm/s)	1 to 100	⊙
Origin offset	-	0	0	0	0	This defines the position after the return to origin is completed. (Unit: 0.01mm)	Product stroke(-) to Product stroke(+)	⊙
ORIG limit	-	70	50	70	70	A pushing force level at which to set the origin. (Unit: 1%)	0 to 100	⊙
ORIG speed	-	20	30	30	30	The allowable speed to move to origin. (Unit: 1mm/s)	Input limit value to Maximum speed for each product	⊙
Origin return direction	-	In-line: + direction Parallel: - direction				Change the co-ordinate. The direction will be opposite from the return to origin when the setting is changed. Therefore, the return to origin is required. 	+ direction - direction	○
Zero position setting distance	-	300	300	300	300	Set the amount of movement to be offset after sensor or torque detection during home return. (Unit: 0.01mm) (The specified amount as the origin of the moved position.)	0 to product stroke	○
ORIG anomalous hours	-	200	200	200	200	If homing is not completed within this set time, an alarm occurs. If the homing speed is reduced, set the value according to the speed. (Unit: 1s)	1 to 65535	⊙
Initial position width	-	50	50	50	50	Indicates the range where INP turns ON at the position after homing. (Unit: 0.01mm)	0.01 to Product stroke	⊙
Acceleration and Deceleration ratio	-	10	10	10	10	Sets the level of followability of acceleration/deceleration. Followability to the acceleration becomes loose as the setting value increases. (Becomes close to the trapezoidal acceleration as the setting value reaches 0)	10 to 100	⊙

Setting	Lead	Default value				Description	Input range	Load
		LE2FS16	LE2FS25	LE2FS32	LE2FS40			
JOG speed	H	Input limit value for each product				The speed of Jogging / Inching is set by this setting. (Unit: 1mm/s)	Input limit value to Maximum speed for each product	◎
	A							
	B							
	C							
JOG acceleration	-	1000	1000	1000	1000	The acceleration of Jogging / Inching is set by this setting. (Unit: 1mm/s <sup>2</sup> )	1 to 10,000	◎
JOG deceleration	-	1000	1000	1000	1000	The deceleration of Jogging / Inching is set by this setting. (Unit: 1mm/s <sup>2</sup> )	1 to 10,000	◎
JOG Torque	-	100	100	100	100	The torque limit of Jogging / Inching is set by this setting. (Unit: 1%)	1 to 100	◎
Move distance	-	1000	1000	1000	1000	The distance of Inching is set by this setting. (Unit: 0.01mm)	0 to product stroke	◎
Safe speed limit	H	Input limit value for each product				Set the maximum speed value when safe speed limit is enabled. (Unit: 1mm/s)	Input limit value to Maximum speed for each product	◎
	A							
	B							
	C							
Torque when held (Note.1)	-	70	50	70	70	Sets the torque when stopped after the positioning operation. (Unit: 1%)	1 to 100	◎
Position loop P Constant	H	-	140	80	80	Sets the position loop P constant. ※Please perform the actuator operation after changing this parameter setting under the responsibility of the user.	1 to 200	◎
	A	100	140	110	110			
	B	100	100	80	80			
	C	130	110	80	80			
Velocity loop P Constant	H	-	80	140	140	Sets the Velocity loop P constant. ※Please perform the actuator operation after changing this parameter setting under the responsibility of the user.	1 to 200	◎
	A	150	110	140	140			
	B	160	120	75	100			
	C	160	150	120	120			
Velocity loop I Constant	H	-	50	80	80	Sets the Velocity loop I constant. ※Please perform the actuator operation after changing this parameter setting under the responsibility of the user.	10 to 200	◎
	A	120	110	50	50			
	B	150	90	60	60			
	C	100	100	60	60			
Positioning time level	-	20	20	20	20	Sets the time to generate the positioning time error alarm. (Unit: 0.1s)	0.1 to 25.5	◎

## Caution

The direction in which the electric actuator returns to its origin depends on the electric actuator and the "rotation direction reference" parameter.

If movement is obstructed during the return to origin, a normal return to origin will not be possible.

Therefore, make sure that there are no obstacles or loads within the movable range before returning to origin so that the actuator can perform the full stroke operation.

\*1 For vertical use, do not change the torque when held from the Default value.

For horizontal use, it is possible to lower the torque when held from the Default value, but after changing the torque when held, check if there is any problem with the behavior when the actuator stops.

## 8 Options

The optional parts described below are available (sold separately).

- Actuator cable

### 8.1 Actuator cable

JX - CP - D - □

• Cable length (L)

Cable length(L)	L	D
1	1.5 m	8 mm
3	3 m	
5	5 m	
8	8 m	
A	10 m	11 mm
B*	15 m	
C*	20 m	

\* Produced upon receipt of order

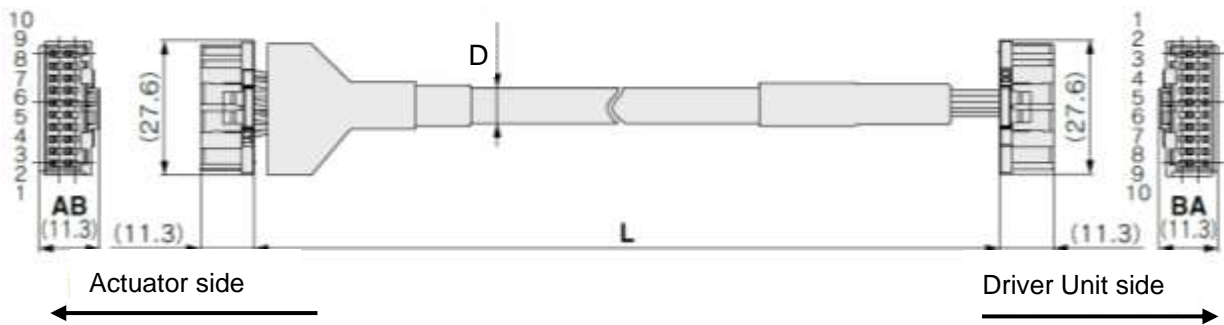

\*Common cable with/without lock

#### Revision history

January 2024: First edition  
April 2024: Second edition  
August 2024: Third edition

# SMC Corporation

4-14-1, Sotokanda, Chiyoda-ku, Tokyo 101-0021 JAPAN  
Tel: + 81 3 5207 8249 Fax: +81 3 5298 5362  
URL <https://www.smcworld.com>

---

Note: Specifications are subject to change without prior notice and any obligation on the part of the manufacturer.  
© 2024 SMC Corporation All Rights Reserved

