



# Operation Manual

PRODUCT NAME

*Pilot Operated 2Port Solenoid Valve*

MODEL / Series / Product Number

J S X H 3 1 - C P \* \* \* - \* \* - \* - X 2

**SMC Corporation**

# Contents

Contents.....	P1
Safety Instructions.....	P2,3
1. Precautions for Design.....	P4
2. Operating Environment.....	P5
3. Precautions for Fluid.....	P5
4. Fluid Quality.....	P6
5. Installation.....	P6
6. Piping.....	P6, 7
7. Wiring.....	P8
8. Electrical Connection.....	P9,10
9. Electric Circuit.....	P10,11
10. Maintenance and Inspection.....	P11
11. Replacement Parts.....	P11
12. Return of Product.....	P11
13. Models.....	P12
14. Specifications.....	P13
15. Construction.....	P13
16. Definition and Terminology.....	P14
17. Troubleshooting.....	P14
18. Trouble Check Sheet.....	P15 to 17



# Metso Valve Controller Safety Instructions

These safety instructions are intended to prevent hazardous situations and/or equipment damage. These instructions indicate the level of potential hazard with the labels of “**Caution**,” “**Warning**” or “**Danger**.” They are all important notes for safety and must be followed in addition to International Standards (ISO/IEC)<sup>\*)</sup>, and other safety regulations.

\*) ISO 4414: Pneumatic fluid power - General rules and safety requirements for systems and their components  
ISO 4413: Hydraulic fluid power - General rules and safety requirements for systems and their components  
IEC 60204-1: Safety of machinery - Electrical equipment of machines - Part 1: General requirements  
ISO 10218-1: Robots and robotic devices - Safety requirements for industrial robots - Part 1: Robots  
etc.



## **Danger**

**Danger** indicates a hazard with a high level of risk which, if not avoided, will result in death or serious injury.



## **Warning**

**Warning** indicates a hazard with a medium level of risk which, if not avoided, could result in death or serious injury.



## **Caution**

**Caution** indicates a hazard with a low level of risk which, if not avoided, could result in minor or moderate injury.

## **Warning**

### **1. The compatibility of the product is the responsibility of the person who designs the equipment or decides its specifications.**

Since the product specified here is used under various operating conditions, its compatibility with specific equipment must be decided by the person who designs the equipment or decides its specifications based on necessary analysis and test results. The expected performance and safety assurance of the equipment will be the responsibility of the person who has determined its compatibility with the product. This person should also continuously review all specifications of the product referring to its latest catalog information, with a view to giving due consideration to any possibility of equipment failure when configuring the equipment.

### **2. Only personnel with appropriate training should operate machinery and equipment.**

The product specified here may become unsafe if handled incorrectly. The assembly, operation and maintenance of machines or equipment including our products must be performed by an operator who is appropriately trained and experienced.

### **3. Do not service or attempt to remove product and machinery/equipment until safety is confirmed.**

1. The inspection and maintenance of machinery/equipment should only be performed after measures to prevent falling or runaway of the driven objects have been confirmed.
2. When the product is to be removed, confirm that the safety measures as mentioned above are implemented and the power from any appropriate source is cut, and read and understand the specific product precautions of all relevant products carefully.
3. Before machinery/equipment is restarted, take measures to prevent unexpected operation and malfunction.

### **4. Our products cannot be used beyond their specifications. Our products are not developed, designed, and manufactured to be used under the following conditions or environments. Use under such conditions or environments is not covered.**

1. Conditions and environments outside of the given specifications, or use outdoors or in a place exposed to direct sunlight.
2. Use for nuclear power, railways, aviation, space equipment, ships, vehicles, military application, equipment affecting human life, body, and property, fuel equipment, entertainment equipment, emergency shut-off circuits, press clutches, brake circuits, safety equipment, etc., and use for applications that do not conform to standard specifications such as catalogs and operation manuals.
3. Use for interlock circuits, except for use with double interlock such as installing a mechanical protection function in case of failure. Please periodically inspect the product to confirm that the product is operating properly.



# Metso Valve Controller Safety Instructions

## Limited warranty and Disclaimer/Compliance Requirements

The product used is subject to the following "Limited warranty and Disclaimer" and "Compliance Requirements". Read and accept them before using the product.

### Limited warranty and Disclaimer

**Scope of Warranty:** Warranty shall be granted for non-conformity of the Company's product ("Product") to the relevant specifications. Any such non-conformity resulting from wear of expendable parts resulting from the Customer's normal use thereof, or from the Customer's inappropriate, insufficient or inexperienced maintenance or from the Customer's inappropriate storage, installation, use, operation or the like, or from the Customer's modification or the like are excluded from warranty.

**Period of Warranty:** One (1) year from the commencement of use by the Customer or one year and half (1.5) from the delivery of the Product; whichever expires earlier.

**Claiming Procedures:** If the Customer determines that the Product is non-conforming, the Customer shall immediately notify the Company. If the notice does not arrive at the Company within two (2) weeks from the date of expiration of the relevant warranty period, the Customer's rights to warranty is forfeited. Even in the case where the notice arrives within the period prescribed above, liability for any damage arising from any delay of the notice shall be borne by the Customer.

**Remedies:** If any non-conformity is actually found in the Product as a result of an inspection made by the Company, the Company shall, upon consultation, repair or replace the Product. The Company will not accept any other claims (such as monetary compensation).

**Related Expenses:** Where the Product is eligible for warranty, shipment expenses therefor shall be borne by the Company. Regardless of whether or not the Product is eligible for warranty, expenses for removal and installation incurred in relation to replacement of the Product shall be borne by the Customer.

**Limitation of Liability:** Even if any legal liability in whichever form other than the warranties set forth above arises in respect of the Company, the Company's scope of liability shall be limited as follows:

- The Company shall be held liable only to the extent that the relevant liability is caused by its act or omission due to its negligence.
- The Company's liability shall not exceed the amount of direct damages incurred by the Customer in respect of the Product, and the Company shall not be held liable for any indirect, contingent, consequential or punitive damage.
- The Company's liability shall not exceed the amount of the sales price of the Product.
- The Company shall not be held liable for any damage caused to the nuclear energy, space or aviation business, for any damage due to any force majeure events including war, terrorist activities or natural disasters, or for compliance with safety regulations or environmental regulations that is beyond the scope of business of the Company.

### Compliance Requirements

1. The use of SMC products with production equipment for the manufacture of weapons of mass destruction (WMD) or any other weapon is strictly prohibited.
2. The exports of SMC products or technology from one country to another are governed by the relevant security laws and regulations of the countries involved in the transaction. Prior to the shipment of a SMC product to another country, assure that all local rules governing that export are known and followed.

# 1. Precautions for Design



## Warning

### 1. Check the specifications.

Fully understand the applications, fluids, environment, and other operating conditions to use this product within the specified range.

Operation outside of the product operating range may cause it to be damaged or malfunction.

SMC does not guarantee against any damage if the product is used outside of the specification range.

### 2. Not suitable for use as an emergency shutoff valve, etc.

This product is not designed as a valve for safety applications such as an emergency shutoff valve.

If the product is used in such a system, additional safety measures should also be implemented.

### 3. This product cannot be used for pressure holding (including vacuum).

Since the valve is subject to air leakage, they cannot be used for applications such as holding pressure (including vacuum) in a pressure vessel.

### 4. Liquid sealing

When flowing liquid is used, install a by-pass valve to the system so that it does not form a liquid-sealed circuit.

### 5. Driving of actuators

When an actuator, such as cylinder, is to be driven by the valve, take appropriate measures in advance to prevent danger due to actuator operation.

### 6. Energized use for extended period of time

If this product is used in an energized state for an extended period of time, the solenoid coil generates heat. Do not use the product in a sealed container. Install the product in a ventilated location. Do not touch the solenoid valves with bare hands during and after energization.

### 7. Water hammer

If impact due to sudden pressure fluctuation, such as water hammer is applied, the valve may be damaged. Therefore, install a water hammer resistant device (accumulator, etc.).

### 8. Leakage at time of fluid supply

Be aware that when the valve is closed and pressure is suddenly applied due to the startup of fluid supply source or for other reason, the valve may open momentarily, and fluid may leak.

### 9. Dual pressure

If there is a possibility that reverse pressure is applied to the valve, take countermeasures such as mounting a check valve on the downstream side of the valve.

### 10. Minimum operating pressure differential

Be aware that even if the pressure difference is above the minimum operating pressure differential when the valve is closed, the pressure difference may fall below the minimum operating pressure differential when the valve opens, depending on the capacity of the supply source (pumps, compressors, etc.) or the type of pipe restrictions (the piping is bent continuously due to elbow or tee, or narrow tube nozzle is installed in the end). If the product is used below the minimum operating pressure differential, the operation becomes unstable due to shortage of pressure difference, which may cause valve opening or closing failure, or oscillation, leading to a failure.

### 11. Prohibition of disassembly and modification

Do not disassemble or modify the product (including additional machining). Failure to follow this instruction may cause bodily injury and/or an accident.

## 2. Operating Environment



### Warning

#### 1. Do not use this product at any of the following locations.

##### 1) Location where the product may be exposed to an atmosphere containing steam, corrosive fluid (chemicals), seawater, or water.

Even on a product with a protection classification (IP65, IP67), take appropriate protective measures in an environment where it is exposed to water for a long time. Failure to follow this instruction may cause moisture to enter the product through fine clearances on its outer surface. For a solenoid valve, entry of moisture may lead to burnout of the coil or short circuit. Check that liquid or splatter does not splash on the product from peripheral equipment when installing this product near equipment that uses a large amount of water or oil, such as machine tools and machining equipment.

##### 2) Location with explosive atmospheres

##### 3) Location where vibration or impact is generated

##### 4) Location where the product is subject to heat sources or radiant heat

##### 5) Location where freezing occurs inside the piping

When the product is to be used in a cold area or in winter, take countermeasures against freezing of the fluid. If the fluid freezes, take countermeasures such as discharge of water from the piping at the time of stopping of the equipment or installing of heaters or thermal insulators on the pipes.

When heating the solenoid valve, do not heat the coil area because doing so degrades the heat dissipation.

## 3. Precautions on Fluid



### Warning

#### 1. Selection of fluid

- 1) To see whether given fluid can be used, check the compatibility between the components and the fluid in the application before use.
- 2) As the compatibility of **fluid** may differ depending on conditions including type, additive, concentration, and temperature. Therefore, pay careful attention when selecting the material. Please contact SMC for details, if necessary.

#### 2. Selection of fluid

The fluid applicable to this product is water only. Do not use the following **fluids**.

- 1) Fluid harmful to human body
- 2) Burnable, combustible fluids
- 3) corrosive gas
- 4) Sea water, saline solution
- 5) Oil, air

#### 3. Take measures to prevent static electricity since some fluids can cause static electricity.

#### 4. Fluid temperature

Use the product with a fluid temperature within the product specification range.

#### 5. Install a filter (strainer) to use clean fluid.

- 1) Use of a fluid that contains foreign matter can lead to problems, such as malfunction and seal failure, attributable to acceleration of wear of the valve seat and iron core, attachment of foreign matter to the iron core sliding part, or other reason. To remove foreign matters, install an appropriate filter (strainer) (100 mesh or higher as a guide) on the upstream side.
- 2) The filter (strainer) may get clogged. Replace or clean it if the pressure has dropped to 0.1 MPa or lower.

## 4. Quality of Fluid



### Warning

#### 1. Water

- 1) Operation failure due to the rust transferred from the piping or chloride flowing in the piping may result in the breakage of the product.  
When the product is broken, fluids or components might be scattered. Therefore, install an appropriate protective measure.
- 2) Water contains substances that generate scale and sludge, such as calcium and magnesium. If they adhere to the internal surface of the valve, a malfunction may occur. Install water softening equipment, which removes those substances, and a strainer on the upstream side of the valve to remove those substances.

## 5. Installation



### Warning

1. **Before installing this product, secure a space necessary for maintenance or inspection.**
2. **Avoid sources of vibration, or adjust the arm from the body to the minimum length so that resonance will not occur.**
3. **Do not install the product near a heat source or exposed to radiant heat.**
4. **Do not apply external force to the coil.**  
When installing this product, apply a spanner to the exterior of the piping connection while paying attention so that it will not come into contact with the coil.
5. **Do not warm the coil with a heat insulator, etc.**  
When the product is heated as a countermeasure against freezing, the portions where the countermeasures are taken should be limited to the piping and body only. Do not heat the coil. Heating the coil may burn it out.
6. **If the leakage increases or the equipment does not operate properly, stop using the product.**  
After installation or during maintenance, check that the product is correctly installed by supplying compressed air and electric power and conducting appropriate functional and leakage inspections. Do not use the product when the equipment does not operate correctly.
7. **Do not touch the valve with bare hands during or immediately after energization.**  
The valve becomes very hot once it is energized. Pay attention not to touch it because doing so can cause burns.



### Caution

#### 1. Painting and coating

Do not erase, remove, or cover up the warnings or specifications printed or attached on the product.

## 6. Piping



### Warning

1. **A tube may detach from the fitting and uncontrollably move when in use due to the deterioration or breakage of the tube.**  
To prevent the tube from breaking loose, install a protective cover or fix the tube securely.
2. **When piping the tubing, fix the valve securely by using the mounting holes on the bottom of the body or a bracket to prevent the product from being lifted.**



### Caution

1. **For handling of one-touch fitting and applicable tubes, refer to "Tube fitting and tube/common precautions" on the SMC catalog.**
2. **Preparation before piping**  
Before piping, sufficiently perform air blow (flushing) or cleaning to remove any cutting chips, cutting oil, dust, etc. from the piping. Connect piping so that forces including tension, compression, and bending force are not applied to the valve body.

### Wrapping of sealant tape

When screwing pipes or fittings into ports, ensure that chips from the pipe threads and sealing material does not enter the valve.

When using sealant tape, leave 1.5 to 2 thread ridges exposed at the end of the threads.

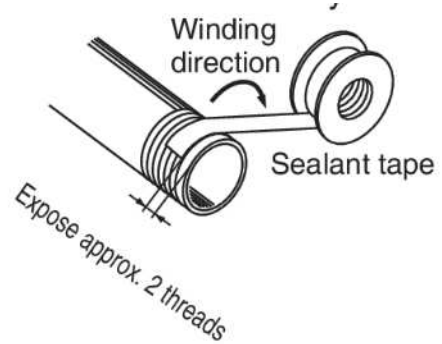

### 3. Screwing-in of pipe and fitting

When connecting a pipe to the valve, tighten it within the allowable torque range below.

#### Tightening torque for piping

Connection thread	Proper tightening torque [N·m]
Rc3/8	22~24
Rc1/2	28~30

### 4. When using a fitting other than an SMC fitting

Follow the manufacturer's instructions.

### 5. Avoid connecting ground lines to piping, as this may cause the system to be corroded by electric corrosion.

### 6. When piping to a product, pay attention not to make connection to wrong supply ports etc.

### 7. Recommended piping conditions

When connecting a pipe to a one-touch fitting, conduct piping with a sufficient margin in tube length in accordance with the recommended piping conditions shown in Fig. 1.

Also, when using a cable tie, etc. to bind pipes together, make sure that an external force does not apply to the fitting. (Refer to Fig. 2.)

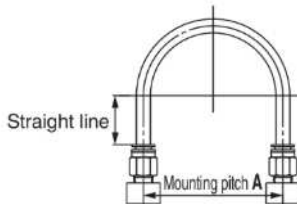

Fig. 1 Recommended piping

Tubing size	Mounting pitch A			Straight line length
	Nylon tubing	Soft nylon tubing	Polyurethane tubing	
φ1/8"	44 or more	29 or more	25 or more	16 or more
φ6	84 or more	39 or more	39 or more	30 or more
φ1/4"	89 or more	56 or more	57 or more	32 or more
φ8	112 or more	58 or more	52 or more	40 or more
φ10	140 or more	70 or more	69 or more	50 or more
φ12	168 or more	82 or more	88 or more	60 or more

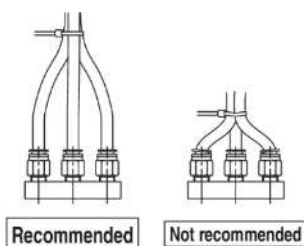

Fig. 2 When using a tying band to bind the piping together



## 7. Wiring

### Warning

1. As a solenoid valve is an electric product, when using it, install an appropriate fuse or breaker for safety.

### Caution

1. Use electric wires for wiring use with a cross section of 0.5 to 1.25 mm<sup>2</sup>.
2. External force applied to lead wire
  - Application of an excessive force to the lead wire may cause the wire to be broken. Make sure that no excessive force greater than 30 N is applied to the lead wire.
  - Do not use the product when the base of the lead wire is bent at 90 degrees or R20 or less.

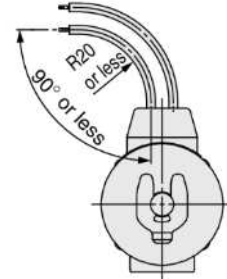

3. Use such an electrical circuit in which chattering does not occur at the contacts.
4. Use voltages in the range of within  $\pm 10\%$  of the rated voltage.
  - If a direct current power supply is used and the response is prioritized, the voltage should be within  $\pm 5\%$  of the rated value.
  - Voltage drop is the value inside the lead wire when the coil is connected.
5. If no solenoid surge is allowed in the electrical circuit system, install a voltage suppressor or similar in parallel to the solenoid. Or use a model with a surge voltage suppressor.
6. Leakage voltage

When operating a solenoid valve with a controller or similar, make sure that the leakage voltage is equal to or lower than products allowable leakage voltage.

In particular be aware that when a resistor is used in parallel with the switching device or a C-R device is used for the protection of a switching device, the valve may not be turned off as leakage voltage passes through the resistor and the C-R device.

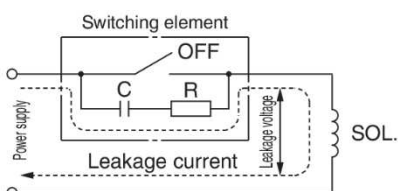

AC coil: 5% or less of the rated voltage  
DC coil: 2% or less of the rated voltage

## 8. Electrical Connection

### Caution

#### 1. Grommet

Lead wire : AWG20 Insulator O.D.:2.6mm

Rated voltage	Lead wire color	
	①	②
DC	Black	Red
100 VAC	Blue	Blue
200 VAC	Red	Red
Other AC	Gray	Gray

\* There is no polarity.

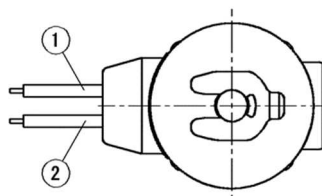

#### 2. Conduit

Lead wire : AWG18 Insulator O.D.:2.8mm

Rated voltage	Lead wire color		
	①	②	③
DC	Black	Red	Green/Yellow
100 VAC	Blue	Blue	Green/Yellow
200 VAC	Red	Red	Green/Yellow
Other AC	Gray	Gray	Green/Yellow

\* There is no polarity.

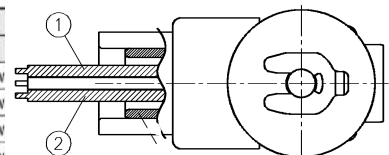

### 3. DIN terminal

#### Disassembly

1. Loosen the binding head screw with the flange, pull the housing up in the arrow direction to remove the solenoid valve from the connector.
2. Pull out the binding head screw with the flange from the housing.
3. Insert a small flat blade screwdriver to the notch at the bottom of the terminal block, and then remove the terminal block from the housing. (Refer to the figure below.)
4. Remove the gland nut and take out the washer and rubber seal.

#### Wiring

1. Put the gland nut, washer, and rubber seal onto the cable in this order, and then insert it into the housing.
2. Loosen the small binding screw of the terminal block, insert the lead wire core or crimp terminal of the lead wire into the terminal, and securely fix it with the small binding screw. The size of the small binding screw of the terminal block is M3.

注1) Tighten the screw to the tightening torque of 0.5 to 0.6 N·m.

注2) Cables with an outside diameter of  $\phi 6$  to  $\phi 12$  mm can be used.

注3) When using cables with an outside diameter of  $\phi 9$  to  $\phi 12$  mm, remove the internal part of the rubber seal.

#### Assembly

1. Put the gland nut, washer, rubber seal, and housing onto the cable in this order, connect the cable to the terminal block, and then mount the terminal block in the housing (Insert the terminal block until it makes a click sound.).
2. Insert the rubber seal and washer to the cable entry of the housing in this order, and then securely tighten the gland nut.
3. Insert the gasket into the gap between the bottom of terminal block and the plug on the equipment, insert the binding screw with flange from the top of housing, and then tighten it.

Note1) Tighten the screw to the tightening torque of 0.5 to 0.6 N·m.

Note2) Depending on the way the housing and terminal block are assembled, it is possible to change the orientation of the connector in units of 90 degrees.

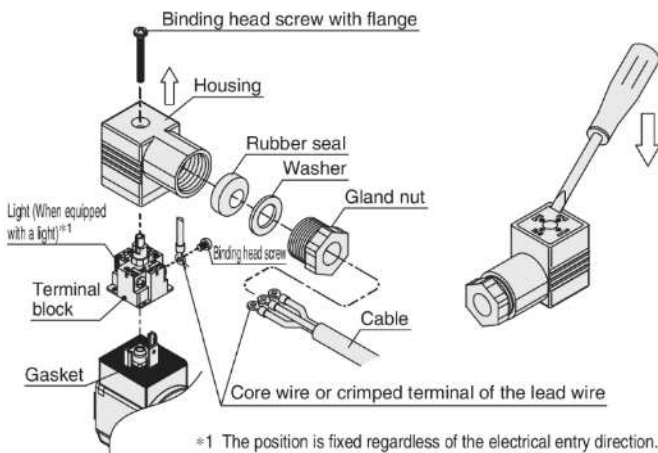

#### ⚠ Caution

Internal connections are as shown below. Make connections to the power supply accordingly.

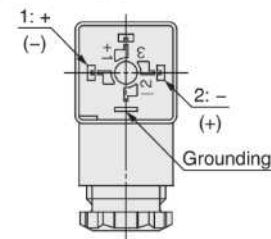

Terminal no.	1	2
DIN terminal	+ (-)	- (+)

#### DIN (EN 175301-803) Terminal

This DIN terminal corresponds to the Form A DIN connector with an 18 mm terminal pitch.

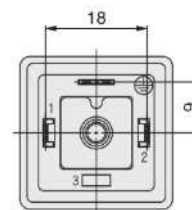

#### 4. M12 connector

- IP67 (enclosure) of the valve can be obtained by using a female connector (with cable) compliant with IP67.  
Note that the product cannot be used underwater.
- Mounting the connector using tools may break the connector. Securely tighten the connector by hand. (0.39~0.49N·m)
- Avoid repeatedly bending or stretching the cable, putting a heavy object on it, or applying a force to the product.
- Do not pull the connector or cable carelessly.
- When installing a connector, do not bend the cable from the base of the connector body.

##### ■ Coding and pin layout of M12 connector on valve side

The shape (coding) and pin layout of M12 connector are as follows.

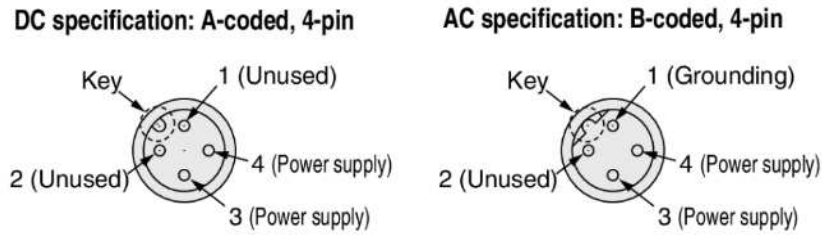

\* There is no polarity for DC voltages.

Use a cable with female connector with compatible coding. When connecting the connector, align the key of the connector on the cable side (female side) with the key of the connector on the valve side (male side).

If the connector is forcefully screwed in with its orientation unaligned, it can cause a failure such as the breakage of pin.

## 9. Electric Circuit

### 1. DC circuit

#### ●Grommet

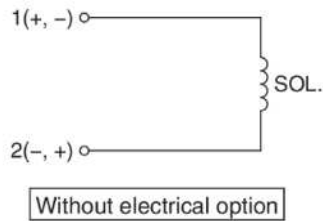

#### ●Grommet/Conduit/DIN terminal

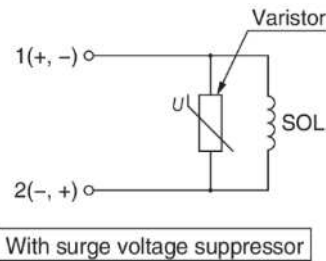

#### ●DIN terminal

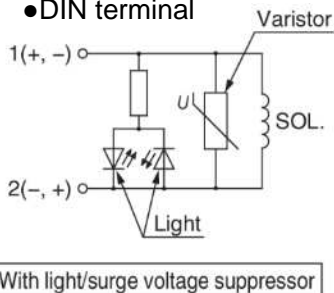

#### ●M12 connector

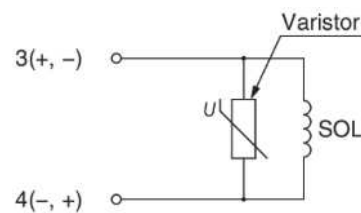

### 2. AC circuit The standard product is equipped with a surge voltage suppressor.

#### ●Grommet/Conduit/DIN terminal/M12 connector

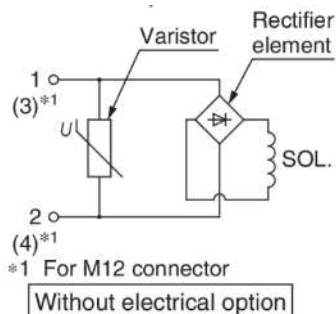

#### ●DIN terminal

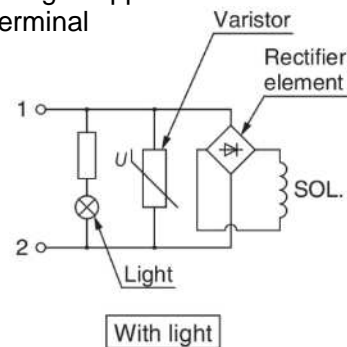

\*1 For M12 connector

## 10. Maintenance and Inspection



### Warning

- 1. Removal of product**
  - 1) Shut off the fluid supply source and release the fluid pressure in the system.
  - 2) Shut off the power supply.
  - 3) Confirm that the valve temperature has dropped sufficiently, and then remove the product.
- 2. Operation at low frequency**

Perform switching of the valve at least once every 30 days to prevent malfunction.  
To use the product in an optimum condition, conduct periodic inspection every six months.
- 3. Storage**

To store the product for an extended period after its use, thoroughly remove all moisture and store it in a location where the product is not exposed to sunlight and high temperature/humidity to prevent rust and deterioration of rubber materials, etc.
- 4. Periodically conduct maintenance and inspection.**

Periodically conduct appropriate functional inspection and leakage inspection to see whether the product is correctly installed.  
If leakage increases or the equipment does not operate properly, stop using the product.

## 11. Replacement Parts

If a replacement part is required for maintenance, make an inquiry to SMC.

## 12. Return of Product



### Warning

If the product being returned is attached or possibly attached with substances, fluid, or its residue that is harmful to humans, for the purpose of securing safety, please first contact SMC, conduct appropriate cleaning (detoxifying processing), submit Product Return Request Sheet or Detoxification/Decontamination certificate to SMC, and receive approval from SMC before returning the product.

Please refer to International Chemical Safety Cards (ICSC) or others for a list of harmful substances. If you have any questions, contact your nearest SMC sales representative.

# 13. Models

## How to order

**JSXH31P-CP04R-5G-A-X2**

1 2 3 4
5 6 7 8
9 10
11
12

### 1 Series

Symbol	Series
H	High-pressure/ Pilot operated

### 2 Size

Symbol	Size
3	30

### 3 Valve type

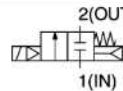
Symbol	Valve type
1	N.C. 

### 4 Main valve construction

Symbol	Main valve construction
P	Piston

### 5 Body material

Symbol	Body material
C	Brass*1

\*1 The orifice material is stainless steel.

### 6 Seal material

Symbol	Seal material	
	Main valve	Pilot valve
P	PPS	PPS

### 7 Port size and orifice diameter

Symbol	Port size	Orifice diameter [mmø]
03	3/8	12
04	1/2	

### 8 Thread type

Symbol	Thread type
R	Rc
N	NPT
F	G

### 9 Rated voltage

AC				DC	
Symbol	Rated voltage	Symbol	Rated voltage	Symbol	Rated voltage
1	100 VAC	4	220 VAC	5	24 VDC
2	200 VAC	7	240 VAC	6	12 VDC
3	120 (110) VAC	8	48 VAC		
		B	24 VAC		







### 11 Option

Symbol	Option
Nil	None
A	Port facing the opposite direction

### 12 Pressure type

Symbol	Specifications
X2	Operating pressure: 0.1 to 10 MPa Fluid: Water

### 10 Electrical entry

Symbol	Electrical entry	CE/UKCA-compliant
G	Grommet*2 	24 VDC
		12 VDC
GS	Grommet with PCB (With surge voltage suppressor) 	100 VAC
		24 VDC
		12 VDC
		48 VAC
	24 VAC	
CS	Conduit (With surge voltage suppressor) 	All voltages
DS	DIN terminal (With surge voltage suppressor) 	All voltages
DZ	DIN terminal with light (With surge voltage suppressor) 	All voltages
DN	Without DIN connector (With surge voltage suppressor) 	All voltages
WN	M12 connector/Without connector cable (With surge voltage suppressor)*3 	All voltages

\*2 DC voltage only

\*3 A cable for the M12 connector is not included with the product.

## 14. Specifications

Size		30		
Valve specifications	Valve construction	Internal pilot type piston		
	Valve type	Normally closed (N.C.)		
	Fluid	Water		
	Fluid temperature	1 to 60°C (No freezing)		
	Ambient temperature	-20 to 60°C		
	Max. operating pressure	10.0 MPa		
	Operating pressure differential	0.1 to 10.0 MPa		
	Withstand pressure	15.0 MPa		
	Port size	3/8	1/2	
	Orifice diameter	12 mmø		
	Flow rate characteristics	Kv	1.7	1.9
		Conversion Cv	2.0	2.2
	Leakage*1	Valve leakage	30 cm <sup>3</sup> /min or less	
		External leakage	0.1 cm <sup>3</sup> /min or less	
Mounting orientation	Unrestricted			
Enclosure*2	IP67 (IP65 for the DIN terminal)			
Body material	Brass, Stainless steel			
Seal material	PPS, NBR			
Weight*3	3/8, Grommet	960 g		
	1/2, Grommet	920 g		
Coil specifications	Rated voltage	AC	24 V, 48 V, 100 V, 110 V, 120 V, 200 V, 220 V, 230 V, 240 V	
		DC*4	12 V, 24 V	
	Allowable voltage fluctuation	±10% of the rated voltage		
	Allowable leakage voltage	AC	5% or less of the rated voltage	
		DC	2% or less of the rated voltage	
	Apparent power*5, 6	AC	9.5 VA	
	Power consumption*5	DC	8 W	
Temperature rise*7	AC	70°C		
	DC	65°C		

\*1 The value for water at a differential pressure of 0.1 MPa or higher and an ambient temperature of 20°C

\*2 This product has an IP67 enclosure, but if water enters the product, it may result in malfunction or breakage.

Therefore, take appropriate measures to prevent water from entering the product when using in an environment where it is constantly exposed to water.

\*3 Add 20 g for the grommet type with PCB, 70 g for the conduit type, 50 g for the DIN terminal type, and 15 g for the type without a DIN connector and the M12 connector type.

\*4 Only DC is available for the grommet type.

\*5 Power consumption/Apparent power: The value at an ambient temperature of 20°C and when the rated voltage is applied (Variation: ±10%)

\*6 There is no difference in the frequency and the inrush and energized apparent power, since a rectifying circuit is used in the AC.

\*7 Temperature rise: The value at an ambient temperature of 20°C and when the rated voltage is applied. Use this value as a reference as the actual value varies depending on the ambient environment.

**Be sure to read the "Specific Product Precautions" before handling the product.**

## 15. Construction

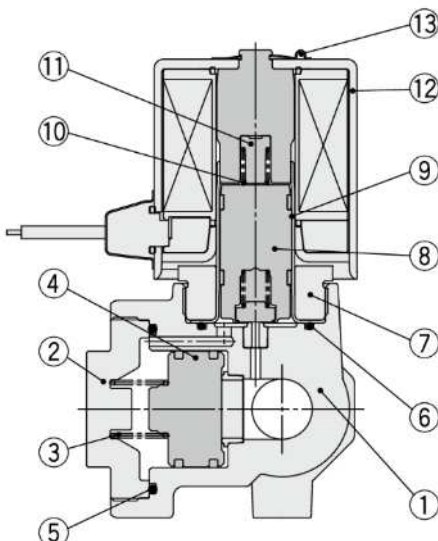

**Component Parts**

No.	Description	Material	Qty.	Note
1	Body	Brass, Stainless steel	1	
2	Bonnet	Brass	1	
3	Spring	Stainless steel 304	1	
4	Main valve assembly	PPS, POM, Stainless steel	1	
5	O-ring	NBR	1	
6	O-ring	NBR	1	
7	Set nut	Brass	1	
8	Armature assembly	Stainless steel, PPS, NBR	1	
9	Tube assembly	Stainless steel	1	High corrosion-resistant electromagnetic stainless steel + Stainless steel 305
10	Spring	Stainless steel 304	1	
11	Stopper	PPS	1	
12	Solenoid coil assembly	Stainless steel, Cu, Resin	1	High corrosion-resistant electromagnetic stainless steel
13	Clip	Stainless steel 304	1	

## 16. Definition and Terminology

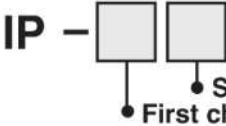
Pressure-related terms	Maximum operating pressure differential	This shows the maximum pressure difference (difference between inlet pressure and outlet pressure) that is allowed for operation. When the downstream side pressure is 0 MPa, this becomes the maximum operating pressure.																																						
	Minimum operating pressure differential	This shows the minimum pressure difference (difference between inlet pressure and outlet pressure) that is required for the main valve to be operated stably.																																						
	Maximum system pressure	This shows the maximum pressure to be applied in the piping. The pressure difference of the solenoid valve needs to be equal to or lower than the maximum operating pressure differential.																																						
	Withstand pressure	This shows the pressure which the product must withstand without lowering its performance when the specified pressure (static pressure) has been retained for one minute and the pressure has returned to the operating pressure range. (Value under the specified conditions)																																						
Electric terms	Apparent power(VA)	Product of voltage (V) and current (A). Its relationship with power consumption is $W = V \cdot A \cdot \cos\theta$ for AC and $W = V \cdot A$ for DC. Note) $\cos\theta$ represents the power factor. $\cos\theta \approx 0.9$																																						
	Surge voltage	Surge voltage is the high voltage spike instantaneously generated at the cut-off area when the electrical power supply is cut off.																																						
	IP Protection Rating	<p>This is the class specified in JIS C 0920: Degrees of protection provided by enclosures (IP Code).</p> <p style="text-align: center;">  </p> <p style="text-align: center;"> <b>● First Characteristics:</b>  <b>Degrees of protection against solid foreign objects</b> </p> <table border="1" style="width: 100%; border-collapse: collapse;"> <tbody> <tr><td>0</td><td>Non-protected</td></tr> <tr><td>1</td><td>Protected against solid foreign objects of 50 mmø and greater</td></tr> <tr><td>2</td><td>Protected against solid foreign objects of 12 mmø and greater</td></tr> <tr><td>3</td><td>Protected against solid foreign objects of 2.5 mmø and greater</td></tr> <tr><td>4</td><td>Protected against solid foreign objects of 1.0 mmø and greater</td></tr> <tr><td>5</td><td>Dust-protected</td></tr> </tbody> </table> <p style="text-align: center;"> <b>● Second Characteristics:</b>  <b>Degrees of protection against water</b> </p> <table border="1" style="width: 100%; border-collapse: collapse;"> <tbody> <tr><td>0</td><td>Non-protected</td><td>—</td></tr> <tr><td>1</td><td>Protected against vertically falling water drops</td><td>Drip-proof type 1</td></tr> <tr><td>2</td><td>Protected against vertically falling water drops when enclosure tilted up to 15°</td><td>Drip-proof type 2</td></tr> <tr><td>3</td><td>Protected against rainfall when enclosure tilted up to 60°</td><td>Rain-proof type</td></tr> <tr><td>4</td><td>Protected against splashing water</td><td>Splash-proof type</td></tr> <tr><td>5</td><td>Protected against water jets</td><td>Water-jet-proof type</td></tr> <tr><td>6</td><td>Protected against powerful water jets</td><td>Powerful water-jet-proof type</td></tr> <tr><td>7</td><td>Protected against the effects of temporary immersion in water</td><td>Immersion type</td></tr> <tr><td>8</td><td>Protected against the effects of continuous immersion in water</td><td>Submersible type</td></tr> </tbody> </table>	0	Non-protected	1	Protected against solid foreign objects of 50 mmø and greater	2	Protected against solid foreign objects of 12 mmø and greater	3	Protected against solid foreign objects of 2.5 mmø and greater	4	Protected against solid foreign objects of 1.0 mmø and greater	5	Dust-protected	0	Non-protected	—	1	Protected against vertically falling water drops	Drip-proof type 1	2	Protected against vertically falling water drops when enclosure tilted up to 15°	Drip-proof type 2	3	Protected against rainfall when enclosure tilted up to 60°	Rain-proof type	4	Protected against splashing water	Splash-proof type	5	Protected against water jets	Water-jet-proof type	6	Protected against powerful water jets	Powerful water-jet-proof type	7	Protected against the effects of temporary immersion in water	Immersion type	8	Protected against the effects of continuous immersion in water
0	Non-protected																																							
1	Protected against solid foreign objects of 50 mmø and greater																																							
2	Protected against solid foreign objects of 12 mmø and greater																																							
3	Protected against solid foreign objects of 2.5 mmø and greater																																							
4	Protected against solid foreign objects of 1.0 mmø and greater																																							
5	Dust-protected																																							
0	Non-protected	—																																						
1	Protected against vertically falling water drops	Drip-proof type 1																																						
2	Protected against vertically falling water drops when enclosure tilted up to 15°	Drip-proof type 2																																						
3	Protected against rainfall when enclosure tilted up to 60°	Rain-proof type																																						
4	Protected against splashing water	Splash-proof type																																						
5	Protected against water jets	Water-jet-proof type																																						
6	Protected against powerful water jets	Powerful water-jet-proof type																																						
7	Protected against the effects of temporary immersion in water	Immersion type																																						
8	Protected against the effects of continuous immersion in water	Submersible type																																						
Others	Material	PPS: Polyphenylene sulfide POM: Polyacetal NBR: Nitrile rubber																																						
	configuration symbol	According to the JIS symbol, when the valve is closed, IN and OUT are blocked. However, if the pressure at port 2 is higher than that at port 1, the valve will not be able to block the fluid flow.																																						

## 17. Troubleshooting

If any failure is found during operation, please check and take measures in accordance with the trouble check sheet.

# 18. Trouble Check Sheet (target series: JSXH31P-CP\*\*\*-\*\*-X2)

Operating conditions

Deliver date	YY/MM/DD
Operating period	XX months
Accumulated operating cycles	Approx. ____ cycles

Warranty period: Within 1.5 years after the product is delivered or 1 year in service

Please refer to and use this trouble check sheet as a diagnosis check sheet for early solution in the event of trouble.

Symptom	Possible cause	Confirmation of condition	Countermeasures	
<p><b>Does not operate</b></p> <p><input type="checkbox"/> Does not turn ON</p>	Power supply voltage is not applied.	<input type="checkbox"/> Is there any abnormality such as failure in power supply and control circuit? <input type="checkbox"/> Is there any abnormality, such as disconnection of wiring system and erroneous wiring?	There is a possibility of abnormality in the power supply, control circuit, or wiring system. 1) Replace or repair the power supply, control circuit, or wiring system.	
	Abnormality in supply pressure	<input type="checkbox"/> Is the operating pressure above the operating pressure differential range?	The operating pressure may be above the operating pressure differential range. 1) Use this product within the operating pressure differential range.	
	Drop of attraction force of solenoid coil	<input type="checkbox"/> Is the product used with the applied voltage below the allowable voltage range? *Lower limit of allowable voltage range: 90% V of rated voltage	As the applied voltage was below the allowable voltage range, the attraction force of the solenoid coil may have lowered and the armature may have not operated. 1) Use this product in the range of rated voltage $\pm 10\%$ V.	
	Burnout and broken wire of solenoid coil	<input type="checkbox"/> Is water or other liquid attached to the coil?	→	If this product is used in an environment where the product is subject to moisture such as water, steam, and dew condensation, water or the like may have entered the solenoid coil. 1) Take a waterproof countermeasure such as installation of a cover on the solenoid coil.
		<input type="checkbox"/> Is surge voltage applied?	→	There is a possibility that an excessively large surge voltage caused burnout or damaged the wire of the solenoid coil. 1) Replace the solenoid coil with a solenoid coil with surge voltage suppressor.
		<input type="checkbox"/> Is surge pressure such as water hammer generated?	→	There is a possibility that surge pressure such as water hammer caused damage. 1) Install a surge pressure mitigating device (accumulator, etc.).
		<input type="checkbox"/> Is the applied voltage above the upper limit of the allowable voltage range? *Lower limit of allowable voltage range: 110% V of rated voltage	→	There is a possibility that the applied voltage is above the upper limit of the allowable voltage range. 1) Use this product in the range of rated voltage $\pm 10\%$ V. 2) Replace the solenoid coil.
	Malfunction of armature	<input type="checkbox"/> Is foreign matter mixed in the fluid? <input type="checkbox"/> Has foreign matter entered the inside of the solenoid valve?	→	There is a possibility that as foreign matter was caught in the sliding part of the armature, the sticking and sealing performance of the armature lowered. 1) Install an appropriate strainer (100 mesh or higher as a guide) on the upstream side of the valve. 2) After piping, conduct air blow of the pipe including the solenoid valve.
		<input type="checkbox"/> Is vibration or impact applied?	→	Malfunction of armature or part breakage due to resonance 1) Use this product at a location not subject to vibration or impact.
	Deterioration or breakage of rubber seal part	<input type="checkbox"/> Are the materials of the solenoid valve parts compatible with the fluid?	→	There is a possibility that malfunction occurred because of shrinkage, deterioration and breakage, or swelling of a rubber seal part.
		<input type="checkbox"/> Is the fluid temperature or ambient temperature above the upper limit of the operating temperature range?	→	There is a possibility that a rubber seal part has been deteriorated due to high temperature. 1) Use this product within the operating temperature range.
		<input type="checkbox"/> Is the product used with fluid temperature or ambient temperature below the lower limit of the operating temperature range?	→	There is a possibility that due to low temperature, a rubber seal part has been hardened or a part was broken due to the freezing of the fluid. 1) Use this product within the operating temperature range. 2) Take countermeasures including installation of heater on the pipe.
		<input type="checkbox"/> Is the operating pressure differential above the maximum operating pressure differential?	→	There is a possibility that a rubber seal part was broken due to excessively large pressure. Use this product at the maximum operating pressure differential or below.



Symptom		Possible cause	Confirmation of condition	Countermeasures
Does not operate	<input type="checkbox"/> Does not turn OFF	Power supply voltage is applied.	<input type="checkbox"/> Is there any abnormality such as failure in the power supply and control circuit? <input type="checkbox"/> Is there any abnormality, such as disconnection of wiring system and erroneous wiring?	<p>→ There is a possibility of abnormality in the power supply, control circuit, or wiring system.</p> <p>1) Replace or repair the power supply, control circuit, or wiring system..</p>
			<input type="checkbox"/> Is the product used with a leakage voltage from the power supply above the allowable value?	<p>→ There may be an influence of the residual magnetic force.</p> <p>1) Use this product with a leakage voltage at the allowable value or below.</p>
		Abnormality in supply pressure	<input type="checkbox"/> Is the operating pressure below the minimum operating pressure differential?	<p>→ There is a possibility that the operating pressure is below the minimum operating pressure differential.</p> <p>1) Use this product within the operating pressure differential range.</p>
		Reverse pressure circuit	<input type="checkbox"/> Is the piping connection direction such that a reverse pressure is applied to the circuit in a reverse system manner?	<p>→ There is a possibility that sealing did not work because of the circuit in which a reverse pressure was applied.</p> <p>1) Check the piping connection direction.</p> <p>In particular, when you use the product for vacuum drawing, connect the upstream side of the solenoid valve to the atmospheric side and its downstream side to the vacuum pump side.</p> <p>2) If a reverse pressure is applied in the piping circuit, install a check valve.</p>
		Malfunction of armature	<input type="checkbox"/> Is foreign matter mixed in the fluid? <input type="checkbox"/> Has foreign matter entered the inside of the solenoid valve?	<p>→ There is a possibility that as foreign matter was caught in the sliding part of the armature, the sticking and sealing performance of the armature lowered.</p> <p>1) Install an appropriate strainer (100 mesh or higher as a guide) on the upstream side of the valve.</p> <p>2) After piping, conduct air blow of the pipe including the solenoid valve.</p>
			<input type="checkbox"/> Is vibration or impact applied?	<p>→ Malfunction of armature or part breakage due to resonance</p> <p>1) Use this product at a location not subject to vibration or impact.</p>
		Deterioration or breakage of rubber seal part	<input type="checkbox"/> Are the materials of the solenoid valve parts compatible with the fluid?	<p>→ There is a possibility that a malfunction occurred because of shrinkage, deterioration and breakage, or swelling of a rubber seal part.</p>
			<input type="checkbox"/> Is the fluid temperature or ambient temperature above the upper limit of the operating temperature range?	<p>→ There is a possibility that a rubber seal part has been deteriorated due to high temperature.</p> <p>1) Use this product within the operating temperature range.</p>
			<input type="checkbox"/> Is the product used with the fluid temperature or ambient temperature below the lower limit of the operating temperature range?	<p>→ There is a possibility that due to low temperature, a rubber seal part has been hardened or a part was broken due to the freezing of the fluid.</p> <p>1) Use this product within the operating temperature range.</p> <p>2) Take countermeasures including installation of heater on the pipe.</p>
			<input type="checkbox"/> Is the operating pressure above the maximum operating pressure differential?	<p>→ There is a possibility that a rubber seal part was broken due to excessively large pressure.</p> <p>Use this product at the maximum operating pressure differential or below.</p>
Fluid leaks out (leakage from valve (internal leakage))	<input type="checkbox"/> Leakage from valve (internal leakage)	Power supply voltage is applied.	<input type="checkbox"/> Is there any abnormality such as failure in the power supply and control circuit? <input type="checkbox"/> Is there any abnormality, such as disconnection of wiring system and erroneous wiring?	<p>→ There is a possibility of abnormality in the power supply, control circuit, or wiring system.</p> <p>1) Replace or repair the power supply, control circuit, or wiring system..</p>
			<input type="checkbox"/> Is the product used with the leakage voltage of the power supply above the allowable value?	<p>→ There may be an influence of the residual magnetic force.</p> <p>1) Use this product with a leakage voltage at the allowable value or below.</p>
		Abnormality in supply pressure	<input type="checkbox"/> Is the operating pressure above the operating pressure differential range?	<p>→ The operating pressure may be above the operating pressure differential range.</p> <p>1) Use this product within the operating pressure differential range.</p> <p>2) Select an appropriate model.</p>
		Reverse pressure circuit	<input type="checkbox"/> Is the piping connection direction such that a reverse pressure is applied to the circuit in a reverse system manner?	<p>→ There is a possibility that sealing did not work because of the circuit in which a reverse pressure was applied.</p> <p>1) Check the piping connection direction.</p> <p>In particular, when you use the product for vacuum drawing, connect the upstream side of the solenoid valve to the atmospheric side and its downstream side to the vacuum pump side.</p> <p>2) If a reverse pressure is applied in the piping circuit, install a check valve.</p>
		Malfunction of armature	<input type="checkbox"/> Is foreign matter mixed in the fluid? <input type="checkbox"/> Has foreign matter been mixed in the solenoid valve?	<p>→ There is a possibility that as foreign matter was caught in the sliding part of the armature, the sticking and sealing performance of the armature lowered.</p> <p>1) Install an appropriate strainer (100 mesh or higher as a guide) on the upstream side of the valve.</p> <p>2) After piping, conduct air blow of the pipe including the solenoid valve.</p>
			<input type="checkbox"/> Is vibration or impact applied?	<p>→ Malfunction of armature or part breakage due to resonance</p> <p>1) Use this product at a location not subject to vibration or impact.</p>

Symptom		Possible cause	Confirmation of condition	Countermeasures
Fluid leaks out	Leakage from valve (internal leakage)	Deterioration or breakage of rubber seal part	Is the fluid temperature or ambient temperature <input type="checkbox"/> above the upper limit of the operating temperature range?	There is a possibility that a rubber seal part has been deteriorated due to high temperature. 1) Use this product within the operating temperature range.
			Is the product used with the fluid temperature or <input type="checkbox"/> ambient temperature below the lower limit of the operating temperature range?	There is a possibility that due to low temperature, a rubber seal part has been hardened or a part was broken due to the freezing of the fluid. 1) Use this product within the operating temperature range. 2) Take countermeasures including installation of heater on the pipe.
	Insufficient air tightness (external leakage)	Deterioration of rubber seal part	Abnormality in supply pressure <input type="checkbox"/> Is the operating pressure above the maximum system pressure?	The operating pressure may be above the maximum system pressure. 1) Use this product at the maximum system pressure or below. 2) Select an appropriate model.
			Inconsistency between allowable leakage values <input type="checkbox"/> Is the allowable leakage value of the solenoid valve (refer to catalog) above the allowable leakage value of the system?	Select a model with non-leak specification.
			Are the materials of the solenoid valve parts compatible with the fluid? <input type="checkbox"/>	There is a possibility that a malfunction occurred because of shrinkage, deterioration and breakage, or swelling of a rubber seal part.
			Is the fluid temperature or ambient temperature <input type="checkbox"/> above the upper limit of the operating temperature range?	There is a possibility that a rubber seal part has been deteriorated due to high temperature. 1) Use this product within the operating temperature range.
Is the product used with the fluid temperature or <input type="checkbox"/> ambient temperature below the lower limit of the operating temperature range?	There is a possibility that due to low temperature, a rubber seal part has been hardened or a part was broken due to the freezing of the fluid. 1) Use this product within the operating temperature range. 2) Take countermeasures including installation of heater on the pipe.			
<input type="checkbox"/> Is the operating pressure differential above the maximum operating pressure differential?	There is a possibility that a rubber seal part was broken due to excessively large pressure. Use this product at the maximum operating pressure differential or below.			
Small flow	Malfunction of armature	Is foreign matter mixed in the fluid? <input type="checkbox"/> Has foreign matter been mixed in the solenoid valve?	There is a possibility that as foreign matter was caught in the sliding part of the armature, the sticking and sealing performance of the armature lowered. 1) Install an appropriate strainer (100 mesh or higher as a guide) on the upstream side of the valve. 2) After piping, conduct air blow of the pipe including the solenoid valve.	
		Is the fluid kinematic viscosity value above the <input type="checkbox"/> allowable value? *Allowable value: 50 mm <sup>2</sup> /s	There is a possibility that the armature malfunctioned due to the increase of the sliding resistance. 1) Use this product at the allowable kinematic viscosity or below. 2) To use this product with high-viscosity fluid, select an air operated valve.	
	Deterioration and breakage of rubber seal part	Deterioration and breakage of rubber seal part	Abnormality in supply pressure <input type="checkbox"/> Is the operating pressure above the operating pressure differential range?	The operating pressure may be above the operating pressure differential range. 1) Use this product within the operating pressure differential range. 2) Select an appropriate model.
			Are the materials of the solenoid valve parts compatible with the fluid? <input type="checkbox"/>	There is a possibility that a malfunction occurred because of shrinkage, deterioration and breakage, or swelling of a rubber seal part.
			Is the fluid temperature or ambient temperature <input type="checkbox"/> above the upper limit of the operating temperature range?	There is a possibility that a rubber seal part has been deteriorated due to high temperature. 1) Use this product within the operating temperature range.
			Is the product used with the fluid temperature or <input type="checkbox"/> ambient temperature below the lower limit of the operating temperature range?	There is a possibility that due to low temperature, a rubber seal part has been hardened or a part was broken due to the freezing of the fluid. 1) Use this product within the operating temperature range. 2) Take countermeasures including installation of heater on the pipe.
<input type="checkbox"/> Is the operating pressure differential above the maximum operating pressure differential?	There is a possibility that a rubber seal part was broken due to excessively large pressure. Use this product at the maximum operating pressure differential or below.			
There is noise	Malfunction of armature	Drop of attraction force of solenoid coil Is the product used with the applied voltage below the allowable voltage range? <input type="checkbox"/> *Lower limit of allowable voltage range: 90% V of rated voltage	As the applied voltage was below the allowable voltage range, the attraction force of the solenoid coil may have lowered and the armature may have not operated. 1) Use this product in the range of rated voltage ±10% V.	
		Abnormality in supply pressure <input type="checkbox"/> Is the operating pressure above the operating pressure differential range?	The operating pressure may be above the operating pressure differential range. 1) Use this product within the operating pressure differential range. 2) Select an appropriate model.	
		Is foreign matter mixed in the fluid? <input type="checkbox"/> Has foreign matter been mixed in the solenoid valve?	There is a possibility that as foreign matter was caught in the sliding part of the armature, the sticking and sealing performance of the armature lowered. 1) Install an appropriate strainer (100 mesh or higher as a guide) on the upstream side of the valve. 2) After piping, conduct air blow of the pipe including the solenoid valve.	

Revision history
------------------

# SMC Corporation

4-14-1, Sotokanda, Chiyoda-ku, Tokyo 101-0021 JAPAN

Tel: + 81 3 5207 8249 Fax: +81 3 5298 5362

URL <https://www.smcworld.com>

---

Note: Specifications are subject to change without prior notice and any obligation on the part of the manufacturer.  
© SMC Corporation All Rights Reserved