



Operation Manual

PRODUCT NAME

FLOATING JOINT

MODEL / Series / Product Number

JB Series

SMC Corporation

Contents

1. Safety Instructions	2
2. Specifications	7
3. Construction	8
4. Replacement Parts	9



Safety Instructions

These safety instructions are intended to prevent hazardous situations and/or equipment damage. These instructions indicate the level of potential hazard with the labels of “Caution,” “Warning” or “Danger.” They are all important notes for safety and must be followed in addition to International Standards (ISO/IEC)^{*1)}, and other safety regulations.

*1) ISO 4414: Pneumatic fluid power - General rules and safety requirements for systems and their components
ISO 4413: Hydraulic fluid power - General rules and safety requirements for systems and their components
IEC 60204-1: Safety of machinery - Electrical equipment of machines - Part 1: General requirements
ISO 10218-1: Robots and robotic devices - Safety requirements for industrial robots - Part 1: Robots
etc.



Danger

Danger indicates a hazard with a high level of risk which, if not avoided, will result in death or serious injury.



Warning

Warning indicates a hazard with a medium level of risk which, if not avoided, could result in death or serious injury.



Caution

Caution indicates a hazard with a low level of risk which, if not avoided, could result in minor or moderate injury.



Warning

1. The compatibility of the product is the responsibility of the person who designs the equipment or decides its specifications.

Since the product specified here is used under various operating conditions, its compatibility with specific equipment must be decided by the person who designs the equipment or decides its specifications based on necessary analysis and test results. The expected performance and safety assurance of the equipment will be the responsibility of the person who has determined its compatibility with the product. This person should also continuously review all specifications of the product referring to its latest catalog information, with a view to giving due consideration to any possibility of equipment failure when configuring the equipment.

2. Only personnel with appropriate training should operate machinery and equipment.

The product specified here may become unsafe if handled incorrectly. The assembly, operation and maintenance of machines or equipment including our products must be performed by an operator who is appropriately trained and experienced.

3. Do not service or attempt to remove product and machinery/equipment until safety is confirmed.

1. The inspection and maintenance of machinery/equipment should only be performed after measures to prevent falling or runaway of the driven objects have been confirmed.
2. When the product is to be removed, confirm that the safety measures as mentioned above are implemented and the power from any appropriate source is cut, and read and understand the specific product precautions of all relevant products carefully.
3. Before machinery/equipment is restarted, take measures to prevent unexpected operation and malfunction.

4. Our products cannot be used beyond their specifications. Our products are not developed, designed, and manufactured to be used under the following conditions or environments. Use under such conditions or environments is not covered.

1. Conditions and environments outside of the given specifications, or use outdoors or in a place exposed to direct sunlight.
2. Use for nuclear power, railways, aviation, space equipment, ships, vehicles, military application, equipment affecting human life, body, and property, fuel equipment, entertainment equipment, emergency shut-off circuits, press clutches, brake circuits, safety equipment, etc., and use for applications that do not conform to standard specifications such as catalogs and operation manuals.
3. Use for interlock circuits, except for use with double interlock such as installing a mechanical protection function in case of failure. Please periodically inspect the product to confirm that the product is operating properly.



Safety Instructions

Caution

We develop, design, and manufacture our products to be used for automatic control equipment, and provide them for peaceful use in manufacturing industries.

Use in non-manufacturing industries is not covered.

Products we manufacture and sell cannot be used for the purpose of transactions or certification specified in the Measurement Act.

The new Measurement Act prohibits use of any unit other than SI units in Japan.

Limited warranty and Disclaimer/Compliance Requirements

The product used is subject to the following “Limited warranty and Disclaimer” and “Compliance Requirements”. Read and accept them before using the product.

Limited warranty and Disclaimer

1. The warranty period of the product is 1 year in service or 1.5 years after the product is delivered, whichever is first.* 2)

Also, the product may have specified durability, running distance or replacement parts. Please consult your nearest sales branch.

2. For any failure or damage reported within the warranty period which is clearly our responsibility, a replacement product or necessary parts will be provided.

This limited warranty applies only to our product independently, and not to any other damage incurred due to the failure of the product.

3. Prior to using SMC products, please read and understand the warranty terms and disclaimers noted in the specified catalog for the particular products.

***2) Vacuum pads are excluded from this 1 year warranty.**

A vacuum pad is a consumable part, so it is warranted for a year after it is delivered.

Also, even within the warranty period, the wear of a product due to the use of the vacuum pad or failure due to the deterioration of rubber material are not covered by the limited warranty

Compliance Requirements

1. The use of SMC products with production equipment for the manufacture of weapons of mass destruction (WMD) or any other weapon is strictly prohibited.

2. The exports of SMC products or technology from one country to another are governed by the relevant security laws and regulations of the countries involved in the transaction. Prior to the shipment of a SMC product to another country, assure that all local rules governing that export are known and followed.

Warning

(1) Confirm the application.

This product is a shaft coupling for linear reciprocating motion used to absorb slight misalignment of the workpiece and the cylinder during linear motion. It is not a shaft coupling for rotation. Do not use it for an application in which rotation or oscillation is applied.

(2) Check the Specifications.

Refer to the catalogue for specifications and dimensions of products. Do not operate the product under loading or temperatures outside of specification. This also applies to eccentricity and rotation angle exceeding the allowable value. Failure to use the joint correctly may cause breakage or malfunction of the product.

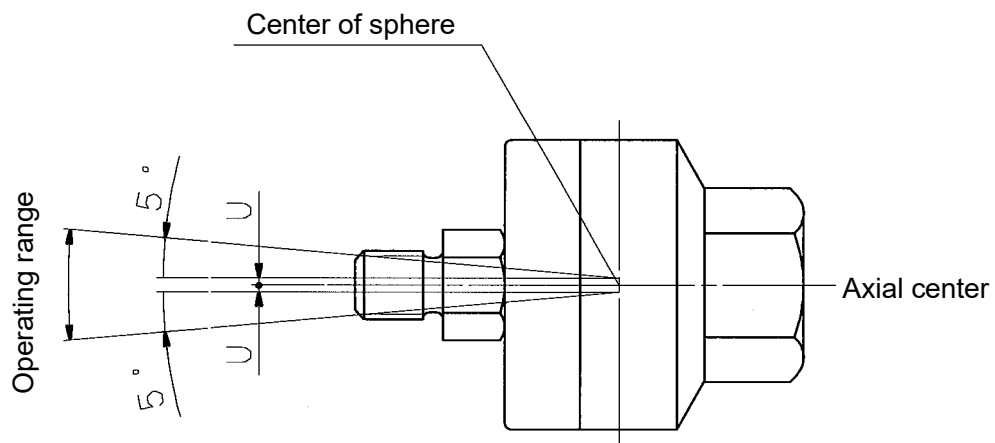

(3) Provide a shock absorbing mechanism in order to prevent impact load when the work piece is stopped.

Be sure to use the cushion mechanism of the cylinder or the buffer mechanism, such as the shock absorber so that any impact force is not applied to the floating joint when stopping a driven body. If there is no buffer mechanism, an excessive impact force is generated. As a result, the tensile compression force of the floating joint may exceed its maximum level.

(4) Install an external stopper to avoid run-away of the equipment.

If there is a risk of equipment damage or injury in the case of equipment running out of control or dropping of the driven object due to loose connecting screws or excessive impact load, install an external stopper to avoid run-away of the equipment.

(5) Play in the axial direction

JB series has play in the axial direction. (Default: 0.06 mm or less) When positioning the driven object, avoid the influence of play using a knock pin or external stopper.

Caution

(1) The black zinc chromate treatment is applied to the material surfaces of the case. However, the white deposit may rarely occur on the surface. This white deposit does not affect the product functions. However, if the white deposit becomes a problem from a viewpoint of appearance, special products with the surface treatment changed to the electroless nickel plating are also available. For details, please contact SMC.

Warning

(1) Maintenance space

Allow sufficient space for maintenance and inspection.

(2) When screwing the male threads of the rod into the female threads of the socket or the case, make sure that it does not contact the stud sphere.

When the rod is screwed into the socket or case female thread, mount the rod end so that it does not contact the stud sphere. If the floating joint is used with a rod contacting the stud sphere, the stud will not be able to float, causing damage. For the screw-in depth of the female threads, refer to the dimensions(catalog). As a guide, loosen the rod 1 to 2 turns from the position where the stud sphere was contacted.

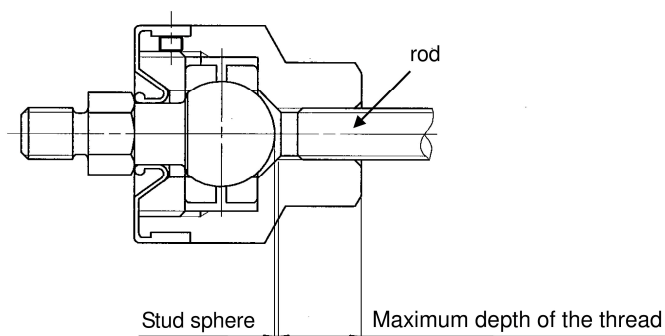

(3) Operate the stud by hand to make it move smoothly before mounting the product to the driven object.

The dust cover may adhere to the stud. In this case, move the dust cover at the neck of the stud by the finger or twist the stud slightly left or right to break in the dust cover before use. Additionally, when screwing the stud and socket or the case into a driven body, screw in such parts with the dust cover removed. When screwing in such parts without removing the dust cover, this may cause damage to the dust cover.

(4) When tightening, only hold the hexagon head part.

When connecting the driven object to the cylinder rod with a floating joint, hold the hexagon head with a spanner and tighten the lock nut to the appropriate torque for the screw size to fasten it securely. The floating joint may be broken if parts other than the hexagon head are gripped or rotated with pliers or a wrench, etc. Also, if there is a risk of loosening during operation, take measures to prevent loosening, such as using a locking pin or thread adhesive. In the event that the connected portion becomes loose, the driven body might lose control or fall off, leading to equipment damage or injury to personnel.

(5) Do not paint the product.

Models or specifications printed or marked on the product should not be erased, removed or covered up. Do not paint rubber parts, as this may have an adverse effect due to the solvent in the paint.

(6) Transportation, installation, piping, wiring, operation, handling, and maintenance should be performed by personnel with sufficient knowledge and experience.

There is a risk of injury.

(7) Do not disassemble or modify the product.

This may cause human injury and/or an accident.

(8) Do not wipe the product using chemicals.

Operating Environment

Warning

(1) Avoid using in a location where the product could be splashed by liquids such as coolants and water. Also, avoid locations where exposed to a large amount of dust or foreign matter.

If liquid or dust gets inside the floating joint from the gap of the dust cover, it may cause a malfunction. Install a protective cover if the product is directly splashed by liquids or foreign matter can be accumulated.

(2) Do not use in an environment where corrosive gases, chemicals, sea water, water or steam are present.

(3) Do not operate in a location subject to vibration or impact.

(4) Use a protective cover, etc. to shield the product from direct sunlight.

(5) Shield the product from radiated heat generated by nearby heat sources.

(6) Employ suitable protective measures in a location where there is contact with oil or welding spatter, etc.

Maintenance

Warning

(1) Removal of equipment, and supply/exhaust of compressed air

When equipment is serviced, first confirm that measures are in place to prevent dropping of driven objects and/or equipment running out of control, etc. Then cut the supply pressure and power, and exhaust all compressed air from the system using its residual pressure release function. When the equipment is to be started again after remounting, first confirm that measures are in place to prevent lurching of actuators, etc., and then confirm that the equipment can operate normally.

(2) Implement regular inspections as necessary when starting-up etc. Confirm that there is no loosening of the connection between the driven object and the cylinder.

Before performing maintenance, confirm that measures are taken to prevent sudden action and protect workers.

(3) If the gap in an axial direction significantly increases or the stud does not operate correctly, stop operation and please do not use the product.

It may lead to injury or damage to the product due to an unexpected motion.

(4) Confirm that there is no weakening of the rubber bumper within the cylinder or adjustment error of the air cushion.

If the rubber bumper of the cylinder is weakened or the adjustment of the air cushion is incorrect, an excessive impact force will be generated when the cylinder reaches its end of stroke, this may cause breakage or malfunction of the product. Replace the cylinder if the rubber bumper is weakening or readjust the air cushion if an adjustment error is found.

(5) Do not reuse if disassembled.

The threaded part cannot be removed from the rest of the joint as they are either welded together or held together using high-strength adhesive. Attempting to forcefully disassemble the joint may result in damage.

2. Specifications

Model	Applicable bore size (mm)	Applicable cylinder nominal thread size	Maximum operating tension and compression force (N)		Allowable eccentricity U (mm)	Rotating angle
			Compression side	Tension side		
JB12-3-050	12	M3×0.5	112	112	0.5	±5°
JB16-4-070	16	M4×0.7	200	200	0.5	
JB20-5-080	20	M5×0.8	1100	300	0.5	
JB25-6-100	25	M6×1	2500	500	0.5	
JB40-8-125	32 · 40	M8×1.25	6000	1300	0.75	
JB63-10-150	50 · 63	M10×1.5	11000	3100	1	
JB80-16-200	80	M16×2	18000	5000	1.25	
JB100-20-250	100	M20×2.5	28000	7900	2	
JB140-22-250	125 · 140	M22×2.5	54000	15300	2.5	
JB160-24-300	160	M24×3	71000	20000	3	

Note 1) Please use the applicable bore size as a guide. For details, confirm the rod end thread diameter of a cylinder to be used in the catalog.

Note 2) The product should be used in an environment where the ambient temperature is from -5°C to 60°C degrees.

3. Construction

JB12 · 16

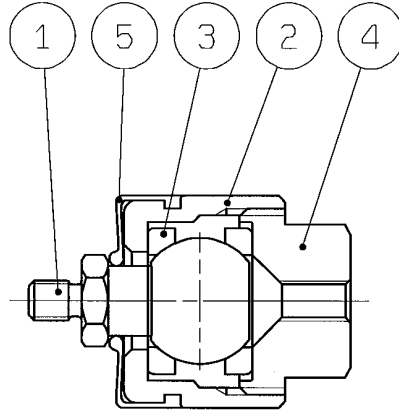

Component Parts

No.	Description	Material	Note
1	Stud	Free-cutting steel	Electroless nickel plated
2	Case	Brass	Electroless nickel plated
3	Ring	Stainless steel	
4	Socket	Brass	Electroless nickel plated
5	Dust cover	Synthetic rubber	

JB20 to 160

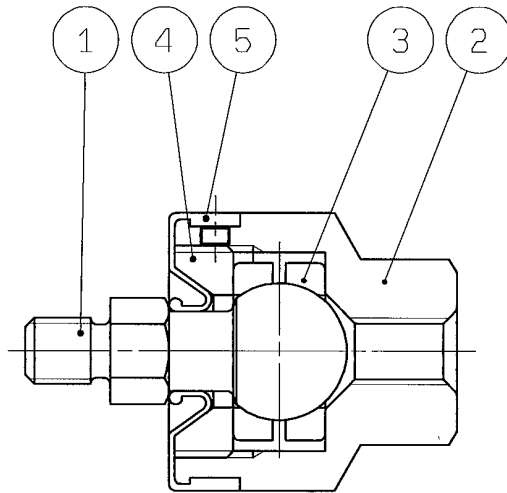

Component Parts

No.	Description	Material	Note
1	Stud	Chromium molybdenum steel	Dyed black
2	Case	Carbon steel	Black zinc chromated
3	Ring	Chromium molybdenum steel	
4	Cap	Carbon steel	Black zinc chromated
5	Dust cover	Synthetic rubber	

4. Replacement Parts

When the dust cover is broken or deteriorated, please order the replacement with part number below.

Only the basic type dust cover is replaceable.

Part no. for dust cover	Applicable models
P2152052	JB12,JB16
P215215	JB20
P215225	JB25
P215235	JB40
P215245	JB63
P215255	JB80
P215265	JB100
P215285	JB140
P215295	JB160

Revision history	
B: Change of the note on the Safety Instructions and Component Parts.	2024.3

SMC Corporation

Tel: + 81 3 5207 8249 Fax: +81 3 5298 5362
URL <https://www.smcworld.com>

Note: Specifications are subject to change without prior notice and any obligation on the part of the manufacturer.
© SMC Corporation All Rights Reserved