



Operation Manual

PRODUCT NAME

*E/P Regulator
(DeviceNet[®] type)*

MODEL/ Series/ Product Number

ITV1000/2000/3000/2090-DE Series*

SMC Corporation

Contents

| | |
|--|-----|
| Safety Instructions | P2 |
| Handling precautions | P4 |
| Wiring method and LED indication | P6 |
| System configuration | P7 |
| Communication specification | P7 |
| Setting of dipswitch | P8 |
| Pressure setting and output monitoring | P10 |
| Communication data | P10 |
| Maintenance and inspection | P11 |



Safety Instructions

These safety instructions are intended to prevent hazardous situations and/or equipment damage. These instructions indicate the level of potential hazard with the labels of “**Caution**,” “**Warning**” or “**Danger**.” They are all important notes for safety and must be followed in addition to International Standards (ISO/IEC)*1), and other safety regulations.

*1) ISO 4414: Pneumatic fluid power - General rules and safety requirements for systems and their components
ISO 4413: Hydraulic fluid power - General rules and safety requirements for systems and their components
IEC 60204-1: Safety of machinery - Electrical equipment of machines - Part 1: General requirements
ISO 10218-1: Robots and robotic devices - Safety requirements for industrial robots - Part 1: Robots
etc.



Danger

Danger indicates a hazard with a high level of risk which, if not avoided, will result in death or serious injury.



Warning

Warning indicates a hazard with a medium level of risk which, if not avoided, could result in death or serious injury.



Caution

Caution indicates a hazard with a low level of risk which, if not avoided, could result in minor or moderate injury.

Warning

1. The compatibility of the product is the responsibility of the person who designs the equipment or decides its specifications.

Since the product specified here is used under various operating conditions, its compatibility with specific equipment must be decided by the person who designs the equipment or decides its specifications based on necessary analysis and test results. The expected performance and safety assurance of the equipment will be the responsibility of the person who has determined its compatibility with the product. This person should also continuously review all specifications of the product referring to its latest catalog information, with a view to giving due consideration to any possibility of equipment failure when configuring the equipment.

2. Only personnel with appropriate training should operate machinery and equipment.

The product specified here may become unsafe if handled incorrectly. The assembly, operation and maintenance of machines or equipment including our products must be performed by an operator who is appropriately trained and experienced.

3. Do not service or attempt to remove product and machinery/equipment until safety is confirmed.

1. The inspection and maintenance of machinery/equipment should only be performed after measures to prevent falling or runaway of the driven objects have been confirmed.
2. When the product is to be removed, confirm that the safety measures as mentioned above are implemented and the power from any appropriate source is cut, and read and understand the specific product precautions of all relevant products carefully.
3. Before machinery/equipment is restarted, take measures to prevent unexpected operation and malfunction.

4. Our products cannot be used beyond their specifications. Our products are not developed, designed, and manufactured to be used under the following conditions or environments. Use under such conditions or environments is not covered.

1. Conditions and environments outside of the given specifications, or use outdoors or in a place exposed to direct sunlight.
2. Use for nuclear power, railways, aviation, space equipment, ships, vehicles, military application, equipment affecting human life, body, and property, fuel equipment, entertainment equipment, emergency shut-off circuits, press clutches, brake circuits, safety equipment, etc., and use for applications that do not conform to standard specifications such as catalogs and operation manuals.
3. Use for interlock circuits, except for use with double interlock such as installing a mechanical protection function in case of failure. Please periodically inspect the product to confirm that the product is operating properly.



Safety Instructions

Caution

We develop, design, and manufacture our products to be used for automatic control equipment, and provide them for peaceful use in manufacturing industries.

Use in non-manufacturing industries is not covered.

Products we manufacture and sell cannot be used for the purpose of transactions or certification specified in the Measurement Act.

The new Measurement Act prohibits use of any unit other than SI units in Japan.

Limited warranty and Disclaimer/Compliance Requirements

The product used is subject to the following "Limited warranty and Disclaimer" and "Compliance Requirements". Read and accept them before using the product.

Limited warranty and Disclaimer

1. The warranty period of the product is 1 year in service or 1.5 years after the product is delivered, whichever is first.*2)

Also, the product may have specified durability, running distance or replacement parts. Please consult your nearest sales branch.

2. For any failure or damage reported within the warranty period which is clearly our responsibility, a replacement product or necessary parts will be provided.

This limited warranty applies only to our product independently, and not to any other damage incurred due to the failure of the product.

3. Prior to using SMC products, please read and understand the warranty terms and disclaimers noted in the specified catalog for the particular products.

***2) Vacuum pads are excluded from this 1 year warranty.**

A vacuum pad is a consumable part, so it is warranted for a year after it is delivered.

Also, even within the warranty period, the wear of a product due to the use of the vacuum pad or failure due to the deterioration of rubber material are not covered by the limited warranty

Compliance Requirements

1. The use of SMC products with production equipment for the manufacture of weapons of mass destruction (WMD) or any other weapon is strictly prohibited.

2. The exports of SMC products or technology from one country to another are governed by the relevant security laws and regulations of the countries involved in the transaction. Prior to the shipment of a SMC product to another country, assure that all local rules governing that export are known and followed.

Handling precautions

Caution

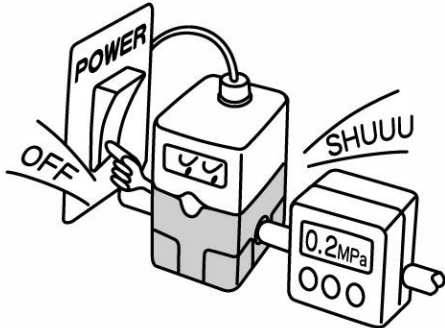

If the power supply to this product is turned off due to a power failure during normal operation, the output on the secondary side will be held and air will flow continuously.

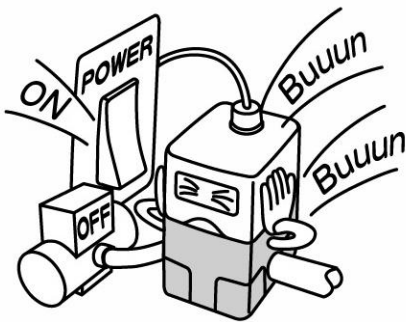

If supply pressure to this product is interrupted or shut off, while the power is still on, the internal solenoid valve will continue to operate and a humming noise will be generated.

Turn off the power supply when supply pressure is interrupted or shut off, since the life of the product may be shortened.

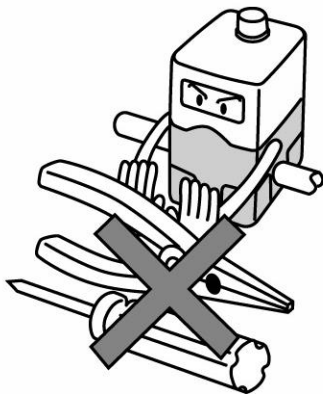

This product is adjusted to specification at the time of shipment from the factory.

Avoid careless disassembly or removal of parts, as this can lead to malfunction.

Caution

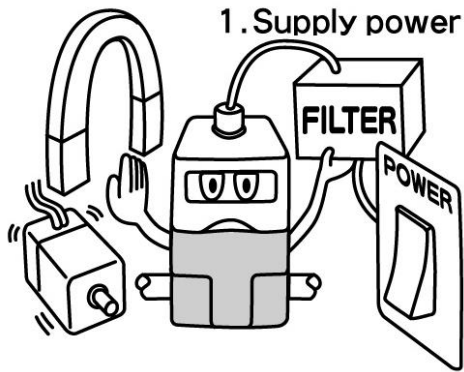

Take the following steps to avoid malfunction due to noise.

1. Install a line filter etc. to the AC power line to reduce / eliminate power supply noise.
2. Avoid malfunction due to noise by installing this product and its wiring away from strong electric fields, such as those of motors and power cables, etc.
3. Be sure to implement protective measures against load surge for inductive loads (solenoid valves, relays etc.).
4. Turn off the power supply before inserting or removing the connector.

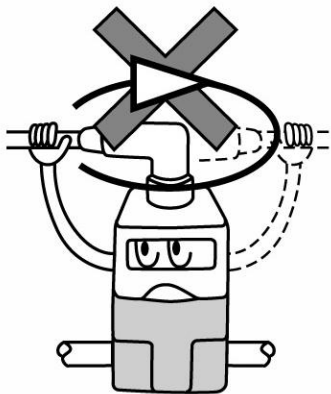

Please note that the right angled cable connector does not rotate and is limited to only one entry direction.

Wiring method and LED indication

⚠ CAUTION

- ① Proceed carefully, as incorrect wiring can cause damage.
- ② Use a DC power supply with sufficient capacity and a low ripple.
Example: Class 2 voltage source. UL1310 compliant.
- ③ Turn off the power supply to remove and insert the connector.
- ④ Never rotate the right angled type connector as it is not designed to rotate.
- ⑤ The communications cable recommends the use of our company PCA-1557633 (socket type).

| DeviceNet™ Connector | | Power supply Connector | |
|----------------------|--------|------------------------|-------|
| M12 5PIN CONNECTOR | | M12 4PIN CONNECTOR | |
| 1 | 4 | 1 | 4 |
| 2 | 3 | 2 | 3 |
| 1. DRAIN | Shield | 1. Vcc | Brown |
| 2. V+ | Red | 2. No Connection | - |
| 3. V- | Black | 3. GND | Blue |
| 4. CAN H | white | 4. No Connection | - |
| 5. CAN L | Blue | | |

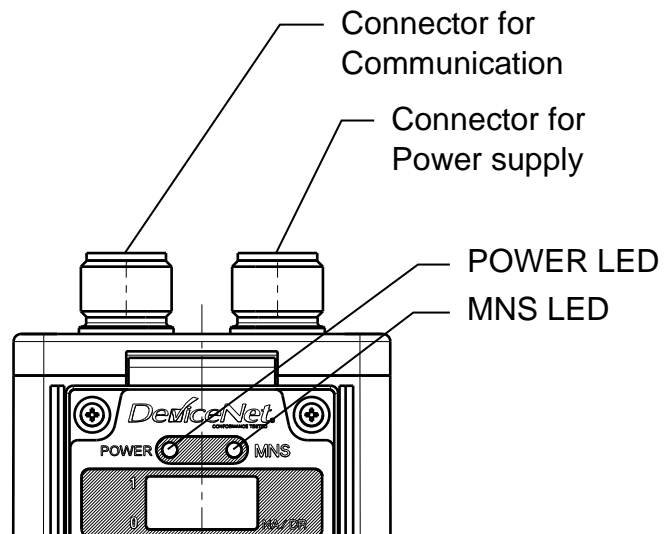

The line color is when the optional cable is used.

■ Connection to external equipment

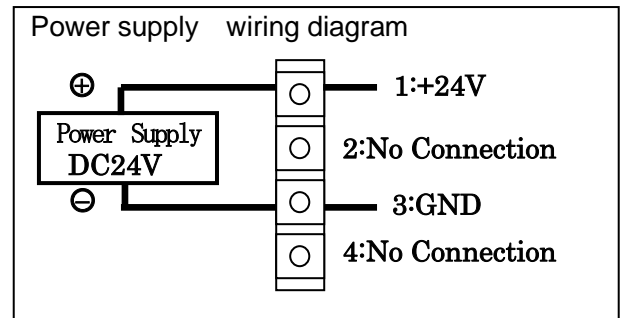
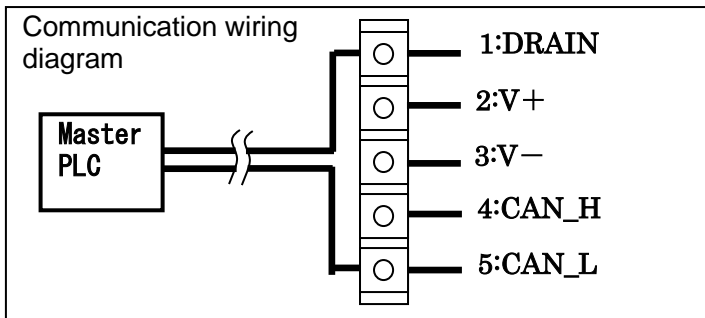

■ LED indication

| Item | Turning ON | Turning OFF | Blinking |
|---------|-------------------|-------------|---|
| POWER | Power ON (Green) | Power OFF | — |
| MOD/NET | ON line (Green) | OFF line | Communication unestablishment (Green) |
| | Fatal error (Red) | | Negligible error (Red) (I/O connection time out) |

System configuration

This product is connected to the field bus (DeviceNet[®]) as a slave.

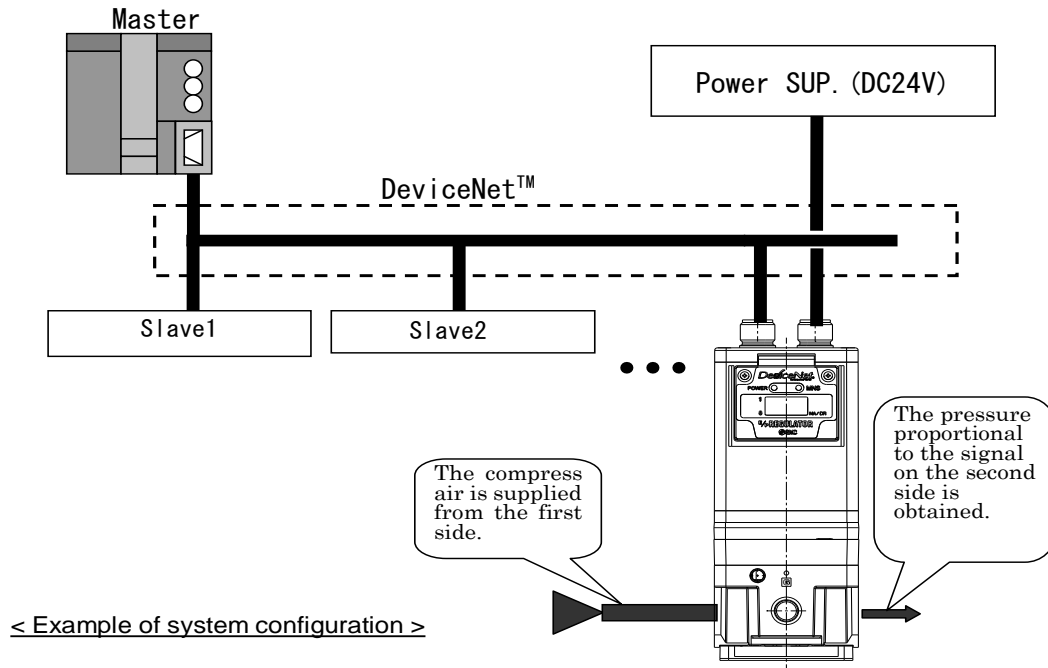

Communication specification

| Item | Specifications | Remarks |
|--------------------------|----------------------------------|--|
| Field bus | DeviceNet [®] | Volume1(Edition3.8) Volume3(Edition1.5) |
| EDS file | ITV-A.EDS ITV-V11.EDS | Down load from Web |
| Slave type | Group 2 Only | |
| Device type | 00h(Generic Device) | |
| MAC ID | 0 to 63 | Due to the dip switch or the master |
| Baud rate (Note) | 125k/250k/500k/ bps | Due to the dip switch or the master |
| Consumed connection size | 2byte (pooled I/O connection) | Target value of pressure |
| Produced connection size | 2byte (pooled I/O connection) | Pressure monitor value |
| Support message | Polled I/O Explicit | |

Note) Baud rate relates to communication distance.

EDS file

Depending on the PLC settings, if the setting file is different, a communication error may occur.

Regarding the EDS file, if it is displayed on the EDS label of the product, please download the EDS file according to the display from our website.

If EDS label is not attached, use ITV-A.EDS for the configuration file. If EDS label is attached, use the setting file described in that EDS label.

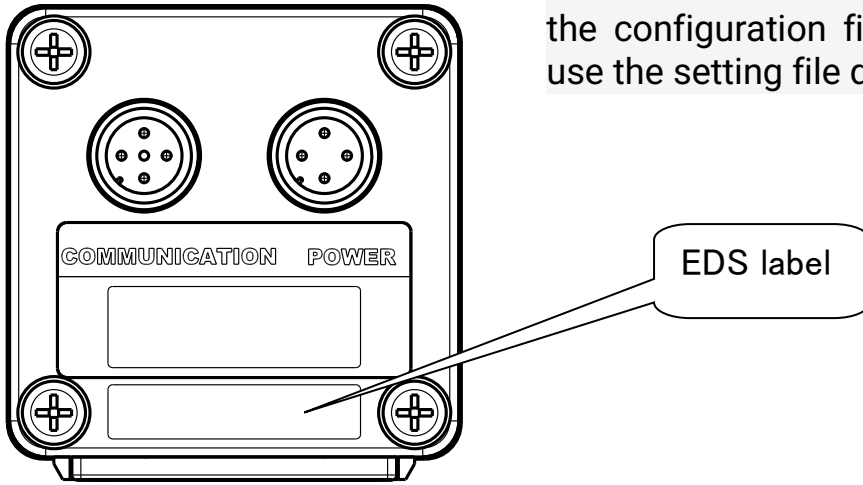

Setting of dipswitch

⚠ CAUTION

- ① Turn off the power supply while setting the switch.
- ② If there is foreign matter or water droplets around the switch cover, clean it off before opening the cover.
- ③ Refer to the drawing below for the setting at the time of shipment from the factory. Confirm the condition of switches before use and reset if necessary.

■ Setting procedure

- ① Loosen the screws of the switch cover.
- ② Open the cover from the bottom upwards.
(See drawing)
- ③ Set switches according to the following procedure.
- ④ After setting the switch, tighten the switch cover in the reverse order of the above procedure.
(Tightening torque 0.6 to 0.8Nm)

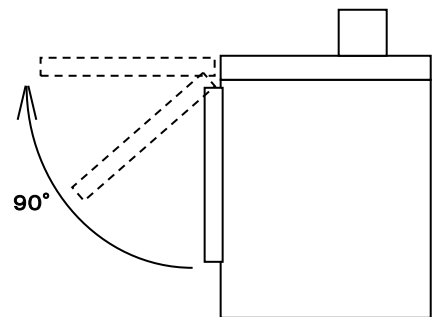

■ Dipswitch

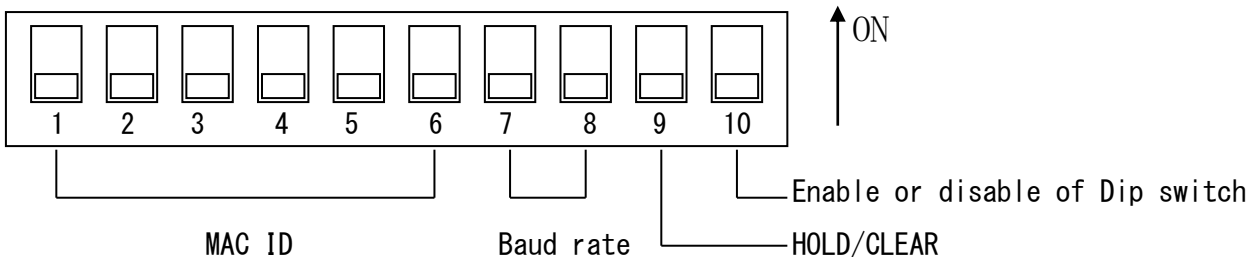

■Setting at the time of shipment

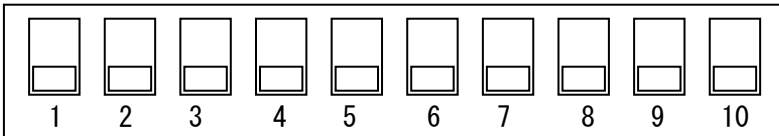

Node address: 0 Baud rate: 125kbps
 Hold/Clear: Clear Dip switch: enable

■Setting of MAC ID

| MAC ID | 1 | 2 | 3 | 4 | 5 | 6 |
|--------|-----|-----|-----|-----|-----|-----|
| 0 | OFF | OFF | OFF | OFF | OFF | OFF |
| 1 | OFF | OFF | OFF | OFF | OFF | ON |
| 2 | OFF | OFF | OFF | OFF | ON | OFF |
| : | : | : | : | : | : | : |
| 62 | ON | ON | ON | ON | ON | OFF |
| 63 | ON | ON | ON | ON | ON | ON |

■Setting of baud rate

| Baud rate | 7 | 8 |
|-----------------|-----|-----|
| 125kbps | OFF | OFF |
| 250kbps | OFF | ON |
| 500kbps | ON | OFF |
| Can not setting | ON | ON |

■Setting of Hold/Clear

This switch is selected to hold or clear the output pressure, when the DeviceNet[®] line causes a communication error due to disconnection.

| Setting | 9 | Function |
|---------|-----|-----------------------------|
| Hold | ON | Hold the output pressure |
| Clear | OFF | Exhaust the output pressure |

When switching off the power supply to ITV in the communication, output pressure is maintained. The condition that the communication begins from power supply re-investing time depends on the setting of dip switch No.9.

■Setting of dip switch

This switch is selected to dip switch enable or disable.

| Setting | 10 |
|---------|-----|
| enable | OFF |
| disable | ON |

Pressure setting and output monitoring

Pressure setting can be done by sending input data using 12bit as F.S. to the electro-pneumatic regulator through the master PLC (e.g. entering a target value to the output word data area).

| | | | |
|-----------------|--------------------------|----------------------------|--|
| Set Date | 0000h | 0FFFh | $[(a / \text{F.S.}) \times 4095]_{\text{HEX}}$ |
| Output pressure | $0\% \times \text{F.S.}$ | $100\% \times \text{F.S.}$ | a |

EX.) To set pressure at 0.3MPa by ITV2030(for 0.5MPa type)

$$(0.3\text{MPa}/0.5\text{MPa}) \times 4095 = 2457 \text{ (DEC)} = 999 \text{ (HEX)}$$

Pressure of 0.3MPa is set by sending input data of "999" to the electro-pneumatic regulator through the master PLC.

Communication data

I/O data (Poll command sending and receiving data)

| Item | Output from PLC (Poll request) | Input to PLC (Poll response) |
|--------------------|-----------------------------------|-----------------------------------|
| Data size | 2Byte(16bit) | 2Byte(16bit) |
| Communication data | $b_{15}, b_{14}, \dots, b_1, b_0$ | $b_{15}, b_{14}, \dots, b_1, b_0$ |

The I/O data occupies two bytes (16bit) respectively.

The pressure is set (output) or is monitored (input) by the data of b_{15}, \dots, b_1, b_0 .

Subordinate position 12bit $b_{11} \dots b_0$ corresponds to 100%FS of pressure.

The pressure setting is assumed that data 1332h of 120%FS is a limit value.

The accuracy guarantee is to 100%FS.

It might response to PLC a very high numerical value such as FFFFh in around outlet pressure 0. It is because of recognition that pressure is a minus side due to the erro, and this is not a failure. (The response data from 8000h to FFFFh shows a minus side.)

Maintenance and inspection

- Turn off the power supply, stop the supplied air, exhaust the residual compressed air and verify the release of air before performing maintenance.
- Foreign matter caught in the inlet of piping or exhaust may interfere with normal operation. Periodic cleaning is necessary.
- Do not use solvents such as benzene, thinner etc. to clean the product including the switch cover. Use a soft cloth to remove stains.

Refer to the SMC website (URL <http://www.smcworld.com>) for more information about troubleshooting.

This operation manual refers to all standard types and is partially applicable to special models.

Revision history

A: P11 Addition note
B: overall revision
C: P6 Add cable color
D: Change of DeviceNet logo
E: Revision of Safety Instructions, Add EDS file

SMC Corporation

Tel: + 81 3 5207 8249 Fax: +81 3 5298 5362

URL <https://www.smcworld.com>

Note: Specifications are subject to change without prior notice and any obligation on the part of the manufacturer.
© SMC Corporation All Rights Reserved