



# Operation Manual

## PRODUCT NAME

*E/P Regulator  
(16points preset input type)*

## MODEL/ Series/ Product Number

*ITV1000/2000/3000/2090-52\* Series*

*(Switch output: NPN output)*

*ITV1000/2000/3000/2090-53\* Series*

*(Switch output: PNP output)*

# Contents

Safety Instructions	P2
Handling precautions	P4
Wiring method	P6
Relation of input signal and preset pressure	P8
Setting method	P8
Key locking function	P9
Setting of min. pressure, max. pressure and preset pressure	P10
Auto memory function	P10
Switch output (Out of range mode)	P11
Error indicating function	P11
Detail setting mode	P12
Gain setting	P12
Sensitivity setting	P13
Zero clear	P14
Initialize	P14
LED display	P15



# Safety Instructions

These safety instructions are intended to prevent hazardous situations and/or equipment damage. These instructions indicate the level of potential hazard with the labels of “**Caution**,” “**Warning**” or “**Danger**.” They are all important notes for safety and must be followed in addition to International Standards (ISO/IEC)<sup>\*1)</sup>, and other safety regulations.

\*1) ISO 4414: Pneumatic fluid power - General rules and safety requirements for systems and their components  
ISO 4413: Hydraulic fluid power - General rules and safety requirements for systems and their components  
IEC 60204-1: Safety of machinery - Electrical equipment of machines - Part 1: General requirements  
ISO 10218-1: Robots and robotic devices - Safety requirements for industrial robots - Part 1: Robots  
etc.



## **Danger**

**Danger** indicates a hazard with a high level of risk which, if not avoided, will result in death or serious injury.



## **Warning**

**Warning** indicates a hazard with a medium level of risk which, if not avoided, could result in death or serious injury.



## **Caution**

**Caution** indicates a hazard with a low level of risk which, if not avoided, could result in minor or moderate injury.

## **Warning**

### **1. The compatibility of the product is the responsibility of the person who designs the equipment or decides its specifications.**

Since the product specified here is used under various operating conditions, its compatibility with specific equipment must be decided by the person who designs the equipment or decides its specifications based on necessary analysis and test results. The expected performance and safety assurance of the equipment will be the responsibility of the person who has determined its compatibility with the product. This person should also continuously review all specifications of the product referring to its latest catalog information, with a view to giving due consideration to any possibility of equipment failure when configuring the equipment.

### **2. Only personnel with appropriate training should operate machinery and equipment.**

The product specified here may become unsafe if handled incorrectly. The assembly, operation and maintenance of machines or equipment including our products must be performed by an operator who is appropriately trained and experienced.

### **3. Do not service or attempt to remove product and machinery/equipment until safety is confirmed.**

1. The inspection and maintenance of machinery/equipment should only be performed after measures to prevent falling or runaway of the driven objects have been confirmed.
2. When the product is to be removed, confirm that the safety measures as mentioned above are implemented and the power from any appropriate source is cut, and read and understand the specific product precautions of all relevant products carefully.
3. Before machinery/equipment is restarted, take measures to prevent unexpected operation and malfunction.

### **4. Our products cannot be used beyond their specifications. Our products are not developed, designed, and manufactured to be used under the following conditions or environments. Use under such conditions or environments is not covered.**

1. Conditions and environments outside of the given specifications, or use outdoors or in a place exposed to direct sunlight.
2. Use for nuclear power, railways, aviation, space equipment, ships, vehicles, military application, equipment affecting human life, body, and property, fuel equipment, entertainment equipment, emergency shut-off circuits, press clutches, brake circuits, safety equipment, etc., and use for applications that do not conform to standard specifications such as catalogs and operation manuals.
3. Use for interlock circuits, except for use with double interlock such as installing a mechanical protection function in case of failure. Please periodically inspect the product to confirm that the product is operating properly.



# Safety Instructions

## Caution

**We develop, design, and manufacture our products to be used for automatic control equipment, and provide them for peaceful use in manufacturing industries.**

**Use in non-manufacturing industries is not covered.**

Products we manufacture and sell cannot be used for the purpose of transactions or certification specified in the Measurement Act.

The new Measurement Act prohibits use of any unit other than SI units in Japan.

## Limited warranty and Disclaimer/Compliance Requirements

The product used is subject to the following “Limited warranty and Disclaimer” and “Compliance Requirements”. Read and accept them before using the product.

### Limited warranty and Disclaimer

1. The warranty period of the product is 1 year in service or 1.5 years after the product is delivered, whichever is first.\*2)

Also, the product may have specified durability, running distance or replacement parts. Please consult your nearest sales branch.

2. For any failure or damage reported within the warranty period which is clearly our responsibility, a replacement product or necessary parts will be provided.

This limited warranty applies only to our product independently, and not to any other damage incurred due to the failure of the product.

3. Prior to using SMC products, please read and understand the warranty terms and disclaimers noted in the specified catalog for the particular products.

**\*2) Vacuum pads are excluded from this 1 year warranty.**

A vacuum pad is a consumable part, so it is warranted for a year after it is delivered.

Also, even within the warranty period, the wear of a product due to the use of the vacuum pad or failure due to the deterioration of rubber material are not covered by the limited warranty

### Compliance Requirements

1. The use of SMC products with production equipment for the manufacture of weapons of mass destruction (WMD) or any other weapon is strictly prohibited.

2. The exports of SMC products or technology from one country to another are governed by the relevant security laws and regulations of the countries involved in the transaction. Prior to the shipment of a SMC product to another country, assure that all local rules governing that export are known and followed.

# Handling precautions

## Caution

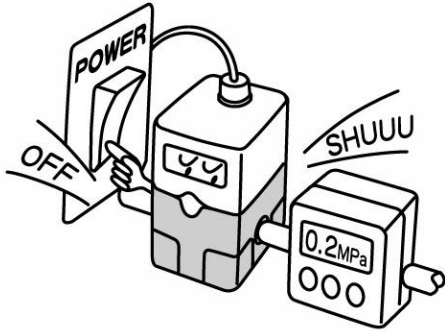

If the power supply to this product is turned off due to a power failure during normal operation, the output on the secondary side will be held and air will flow continuously.

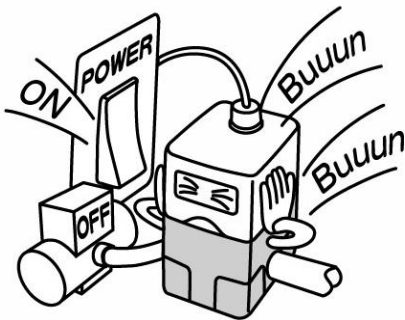

If supply pressure to this product is interrupted or shut off, while the power is still on, the internal solenoid valve will continue to operate and a humming noise will be generated.  
Turn off the power supply when supply pressure is interrupted or shut off, since the life of the product may be shortened.

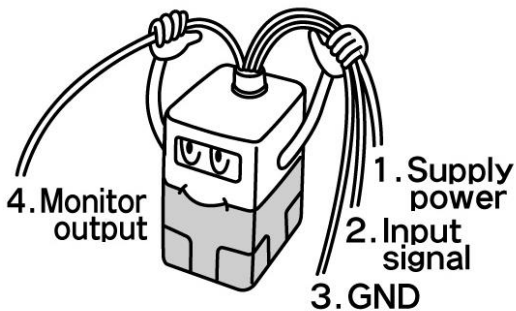

The optional cable connector is a 4 wire type. When the monitor output (switch output) is not being used, prevent the unused wires from touching the other wires, as a malfunction could occur.

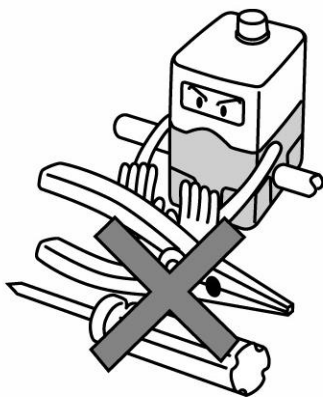

This product is adjusted to specification at the time of shipment from the factory. Avoid careless disassembly or removal of parts, as this can lead to malfunction.

## Caution

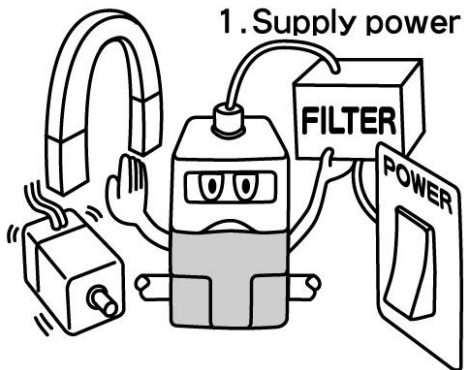

Take the following steps to avoid malfunction due to noise.

1. Install a line filter etc. to the AC power line to reduce / eliminate power supply noise.
2. Avoid malfunction due to noise by installing this product and its wiring away from strong electric fields, such as those of motors and power cables, etc.
3. Be sure to implement protective measures against load surge for inductive loads (solenoid valves, relays etc.).
4. Turn off the power supply before inserting or removing the connector.

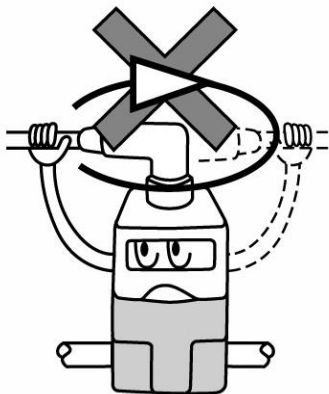

Please note that the right angled cable connector does not rotate and is limited to only one entry direction.

## Wiring method

### Caution

- ① Proceed carefully, as incorrect wiring can cause damage.
- ② Use a DC power supply with sufficient capacity and a low ripple.
- ③ Turn off the power supply to remove and insert the connector.
- ④ Never rotate the right angled type connector as it is not designed to rotate.
- ⑤ When the monitor output is not used, prevent the unused wires from touching the other wires, as this can cause a malfunction.

### ■Pin assign of ITV side connector

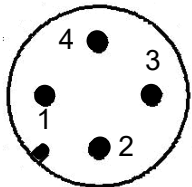
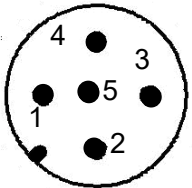
Item	Pin assign	Wire color (Note 1)	
Power supply connector		1. Power supply Vcc	Brown
		2. No Connect	White
		3. GND	Blue
		4. Monitor output	Black
Communication connector		1. Input signal 1	Brown
		2. Input signal 2	White
		3. Input signal 3	Blue
		4. Input signal 4	Black
		5. Common	Gray

Note1) Wire color is when the option cable is used.

### Wiring diagram (Power supply and monitor output)

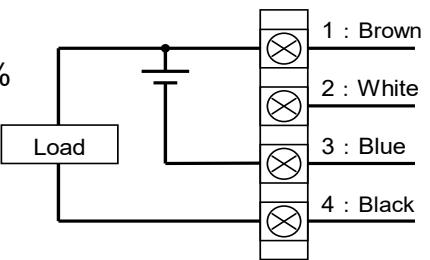
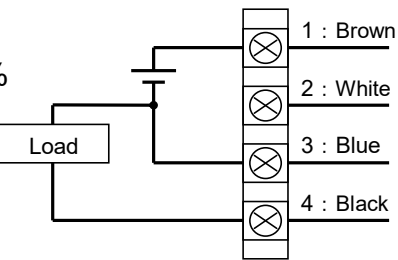
Switch output - NPN type (ITV※0※0-52)	Switch output - PNP type (ITV※0※0-53)
<p>Power supply DC24V±10%</p>  <p>1 : Brown 2 : White 3 : Blue 4 : Black</p>	<p>Power supply DC24V±10%</p>  <p>1 : Brown 2 : White 3 : Blue 4 : Black</p>
<p>When a current of approx.150 mA or more is applied, the over current circuit will operate, "Er.5" will be displayed and the operation will stop. Please install a load to give an output current of 80 mA or less.</p>	<p>When a current of approx.150 mA or more is applied, the over current circuit will operate, "Er.5" will be displayed and the operation will stop. Please install a load to give an output current of 80 mA or less.</p>

## Wiring diagram (Input signal)

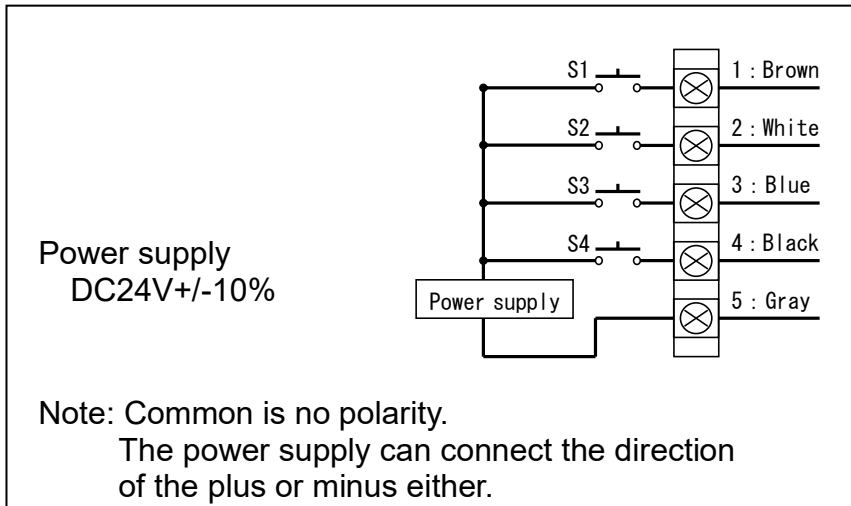

## Relation of Input signal and preset pressure

Preset pressure	Input signal 4 Black: S4	Input signal 3 Blue: S3	Input signal 2 White: S2	Input signal 1 Brown: S1
P01	OFF	OFF	OFF	OFF
P02	OFF	OFF	OFF	ON
P03	OFF	OFF	ON	OFF
P04	OFF	OFF	ON	ON
P05	OFF	ON	OFF	OFF
P06	OFF	ON	OFF	ON
P07	OFF	ON	ON	OFF
P08	OFF	ON	ON	ON
P09	ON	OFF	OFF	OFF
P10	ON	OFF	OFF	ON
P11	ON	OFF	ON	OFF
P12	ON	OFF	ON	ON
P13	ON	ON	OFF	OFF
P14	ON	ON	OFF	ON
P15	ON	ON	ON	OFF
P16	ON	ON	ON	ON

## Setting method

### ⚠ Caution

- ① If an incorrect key is pressed or incorrect information is displayed during setting, power must be turned off and the procedure started again.
- ② It is recommended that the settings are changed without supply pressure. The product operates immediately after preset pressures are set and the S-key is pressed.
- ③ It is recommended that pressure of P01 is output when air is supplied to the inlet, even if the input signal has not been entered.
- ④ Output pressure from this product and state of operation are changed by changing of each setting and function. Each setting and function should be operated by trained and experienced operator.

### Flow of the setting

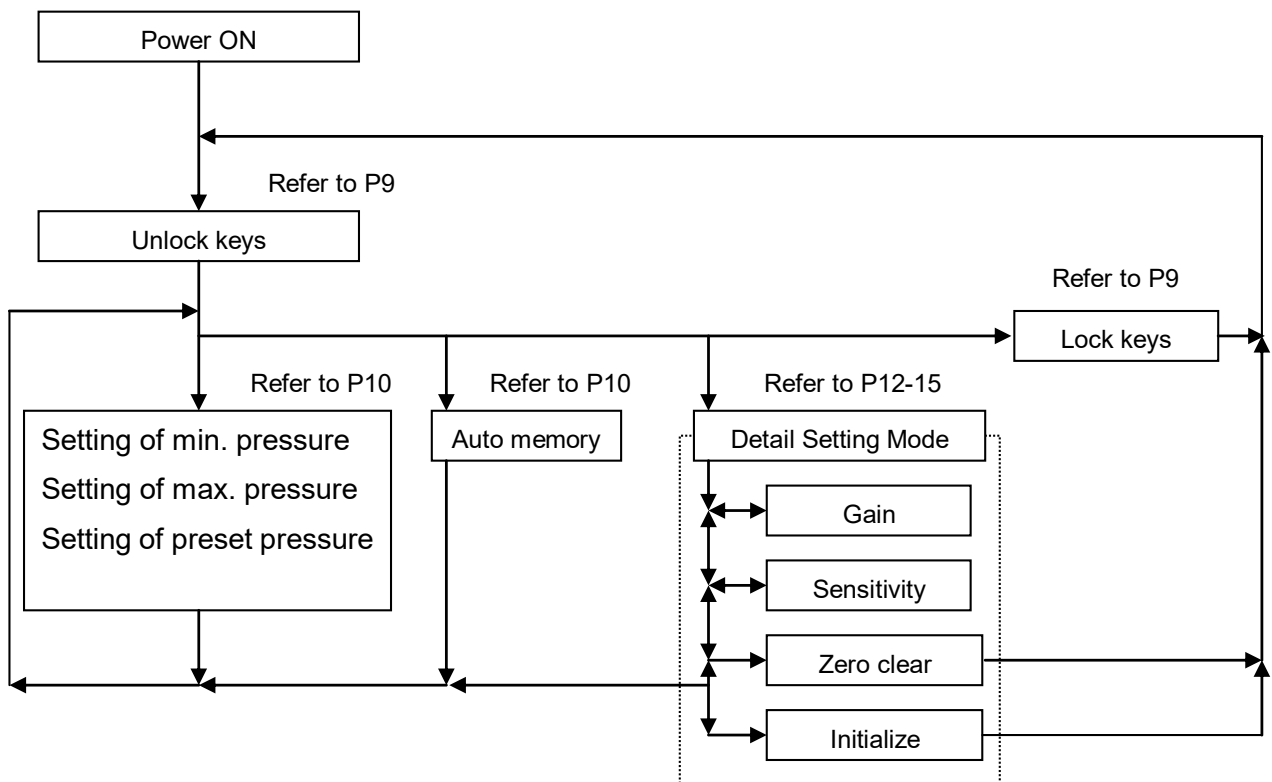

(Note1) Please refer to each section for the operation method.

## Key locking function

### Caution

The keys are locked after turning the power on and can not be operated.

### Unlocking the keys

No	Key operation	LED Display
①		(current) pressure is displayed
②	Press ▽ key for 2 seconds or more.	<i>L O C</i> is displayed
③		<i>L O C</i> flashes on the display
④	Press S-key	
⑤		<i>u n L</i> is displayed for approx. 1 second
⑥	Key lock is released	(current) pressure is displayed

(Note) ④ Press △ key to cancel.

### Locking the keys

No	Key operation	LED Display
①		(current) pressure is displayed
②	Press △ key for 2 seconds or more.	<i>u n L</i> is displayed
③		<i>u n L</i> flashes on the display
④	Press S-key	
⑤		<i>L O C</i> is displayed for approx. 1 second
⑥	Keys are locked	(current) pressure is displayed

(Note) ④ Press ▽ key to cancel.

## Setting of min. pressure, max. pressure and preset pressure

No	Key operation	LED Display
①	Unlock keys (refer to P9)	
②	Press S-key	
③	Set the minimum pressure by using the $\Delta$ and $\nabla$ keys. (Note 1)	$F_1 \leftrightarrow .000$ (displayed alternately) * Adjusting range: Refer to Note 2 to 3
④	Press S-key	(Note 4)
⑤	Set the maximum pressure by using the $\Delta$ and $\nabla$ keys. (Note1)	$F_2 \leftrightarrow .900$ (displayed alternately) * Adjusting range: Refer to Note 2 to 3
⑥	Press S-key	(Note 4)
⑦	Set the P01 by using the $\Delta$ and $\nabla$ keys.	$P01 \leftrightarrow .000$ (displayed alternately)
⑧	Press S-key	(Note 4)
⑨	Set the P02 by using the $\Delta$ and $\nabla$ keys.	$P02 \leftrightarrow .900$ (displayed alternately)
⑩	Press S-key	(Note 4)
⑪	Set P03 to P16 as same.	(Note 4)
⑫	Lock keys (refer to P9)	

(Note1) If auto memory function is not use, jump this item.

(Note2)  $F_1$  is adjustable in a range from 0% to 100% of the rated value. (Default value: 0%)

(Note3)  $F_2$  is adjustable in a range from 0% to 100% of the rated value. (Default value: 0%)

(Note4) Return to (current) pressure display by pressing the SET and  $\Delta$  keys simultaneously even if while you are setting  $F_1$ ,  $F_2$  and P01 to P16.

([---] is displayed for approx. 1 second.)

## Auto memory function

Auto memory function is possible to set the preset pressure in from P01 to P16 automatically. When this function is executed, P01 is set to the value of  $F_1$  and P16 is set to the value of  $F_2$ . And from P02 to P15 is set to the divided value of  $F_1$  and  $F_2$ .

No	Key operation	LED Display
①	Unlock keys (refer to P9)	
②	Press the $\Delta$ and $\nabla$ keys simultaneously for 3 seconds or more.	(Current) pressure is displayed
③	Preset value (divide value of $F_1$ and $F_2$ ) is input in from P01 to P16 automatically.	$ASE$ is displayed momentarily
④	Lock keys (refer to P9)	

## Switch output (Out of range mode)

The switch output turns on when output pressure is achieved to +/-5%F.S. of setting oressure.

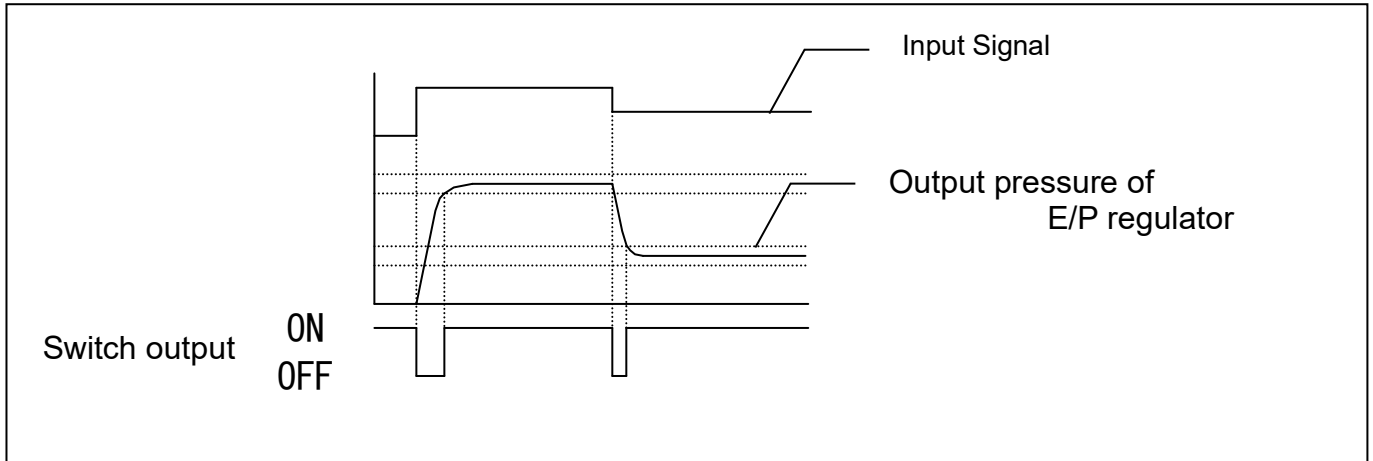

## Error Indicating function

Error name	LED display	Contents of error	Countermeasure
System error	[E1.2]	Reading or writing errors occurred in EEPROM.	Please execute "Initialize (refer to P15)" when the ITV does not operate normally after reconnecting the power supply. Please contact SMC, when the ITV does not operate normally after initialization.
	[E1.3]	Reading and writing errors occurred in memory.	Please contact SMC when the ITV does not operate normally after reconnecting the power supply.
Solenoid valve error	[E1.4]	Solenoid valve failure	Replace the solenoid valve. For the replacement procedure contact SMC.
Over current error	[E1.5]	Over current errors in switch output	Please install a load to give an output current of 80 mA or less.
Residual pressure error	[E1.6]	Out of range error of "Zero clear"	Please operate "Zero clear" within the range of +/- 5% F.S. Please operate "Zero clear" after the secondary pressure of the ITV has reached atmospheric.

## Detail setting mode

No	Key operation and LED display	
①	Unlock keys (refer to P9)	
②	Press S-key for 2 seconds or more.	
③	<pre> graph TD     F01["F01 ↔ 0L9"] -- "Δkey (up)" --&gt; F02["F02 ↔ 5L0"]     F02 -- "∇key (down)" --&gt; F01     F02 -- "Δkey (up)" --&gt; F03["F03 ↔ 0cL"]     F03 -- "∇key (down)" --&gt; F02     F03 -- "Δkey (up)" --&gt; F99["F99 ↔ in 1"]     F99 -- "∇key (down)" --&gt; F03     F99 -- "S-key (right)" --&gt; F01     </pre>	<p>(displayed alternately)</p> <p>Press S-key To "GAIN" (refer to P12)</p> <p>(displayed alternately)</p> <p>Press S-key To "SENSITIVITY" (refer to P13)</p> <p>(displayed alternately)</p> <p>Press S-key To "ZERO CLEAR" (refer to P14)</p> <p>(displayed alternately)</p> <p>Press S-key To "INITIALIZE" (refer to P14)</p>
④	In state of ③, press S-key for 2seconds or more.	
⑤	Return to (current) pressure display.	
⑥	Lock keys (refer to P9)	

## Gain setting

Normal operation does not require the adjustment of gain.

The product can change the response time using this gain setting.

When the gain is changed to a larger value, the response will be faster, but there is a possibility that stability will be lost.

No	Key operation	LED Display
①	Unlock keys (refer to P9)	
②	Press S-key for 2 seconds or more, then go to detail setting mode.	
③	To "F01" by using the $\Delta$ and $\nabla$ keys.	<i>F01</i> ↔ <i>0L9</i> (displayed alternately)
④	Press S-key.	
⑤	Set the GAIN by using the $\Delta$ and $\nabla$ keys.	<i>0L9</i> (blink and change the most right digit)
⑥	Press S-key.	<i>F01</i> ↔ <i>0L9</i> (displayed alternately)
⑦	Press S-key for 2 seconds or more, then go out from detail setting mode. (Select the menu with $\Delta$ or $\nabla$ keys, then jump to another item.)	
⑧	Lock keys (refer to P9)	



## Zero clear

The display can be reset to zero by executing "Zero clear".

When "Zero clear" is executed with residual pressure in the secondary piping, the pressure is assumed to be zero. Please execute the operation of "Zero clear" with the supply pressure interrupted, and the piping of the secondary side removed.

No	Key operation	LED Display
①	Unlock keys (refer to P9)	
②	Press S-key for 2 seconds or more, then go to detail setting mode.	
③	To "F03" by using the $\Delta$ and $\nabla$ keys.	F03 $\leftrightarrow$ 0cL (displayed alternately)
④	Press S-key.	0cL (displayed alternately)
⑤	Press $\Delta$ and $\nabla$ keys for 3 seconds or more. (press S-key to ③)	0cL (is displayed)
⑥	"Zero clear" is executed, after 3 seconds. (Release keys till less than 3 seconds to ④)	cLr (is displayed for approx. 1 second)
⑦	Returns to the state immediately after turning on the power supply. (keys are locked)	

(Note) The adjustable range is within +/- 5% F.S from the state of the factory shipment. When outside of this range, *Err* is displayed and "Zero clear" will not be executed.

## Initialize

"Initialize" is a function to return all the settings that the internal control constant are included to an initial value. Please execute "initialize" only when the error is displayed and this product does not operate at all.

No	Key operation	LED Display
①	Unlock keys (refer to P9)	
②	Press S-key for 2 seconds or more, then go to detail setting mode.	
③	To "F99" by using the $\Delta$ and $\nabla$ keys.	F99 $\leftrightarrow$ 117 (displayed alternately)
④	Press S-key.	117 displayed alternately
⑤	Press $\Delta$ and $\nabla$ keys for 3 seconds or more. (press S-key to ③)	117 is displayed
⑥	"Initialize" is executed, after 5 seconds. (Release keys till less than 5 seconds to ④)	Turning off for 1 second

⑦

Returns to the state immediately after turning on the power supply.  
(keys are locked)

## LED display

The range of the LED pressure display is different according to the pressure range and the unit of the display.

unit	ITV※010	ITV※030	ITV※050	ITV2090
MPa	。020~.120	。100~.600	。180~.A80	-
Kgf/cm <sup>2</sup>	0。20~.120	1。00~6.00	1。80~A.80	-
bar	0。20~.120	1。00~6.00	1。80~A.80	-
PSI	3。0~18.0	14。0~84.0	-26~156	-
kPa	-20~120	-100~600	-180~A80	16~-96

(note1) : The mark "。" is blinking the decimal point, and it is shown a minus.

(note2) : When the digit overflows, the following of "9" are substituted by "A".

(example: The following of 999(kPa) are displayed as A00(kPa), and it shows 1000 kPa.)

(note3) : When the display exceeds the lower bound value, "LLL" is displayed.

(note4) : When the display exceeds the upper bound value, "HHH" is displayed.

Refer to the SMC website (URL <http://www.smcworld.com>) for more information about troubleshooting.

This operation manual refers to all standard types and is partially applicable to special models.

### Revision history

B : Change of "Safety Instructions"  
 C : P15 Addition note  
 D : P6 Correction of error in writing of pin assign.  
 E : Revision of Safety Instructions  
 F : P6 Correction of error in writing of pin assign and Initialize text(P14,P15).

## SMC Corporation

URL <https://www.smcworld.com>

Note: Specifications are subject to change without prior notice and any obligation on the part of the manufacturer.  
 © SMC Corporation All Rights Reserved