



# Operation Manual

PRODUCT NAME

Air Catch Sensor

MODEL / Series / Product Number

*ISA2*

**SMC Corporation**

## Table of Contents

Safety Instructions	3
Model Indication and How to Order	12
Summary of Product parts	14
Definition and terminology	15
Mounting and Installation	16
Wiring	18
Setting	19
Designing data	21
Troubleshooting	24
Specification	27
Specifications	27
Dimensions	28



# Safety Instructions

These safety instructions are intended to prevent hazardous situations and/or equipment damage. These instructions indicate the level of potential hazard with the labels of “**Caution**,” “**Warning**” or “**Danger**.” They are all important notes for safety and must be followed in addition to International Standards (ISO/IEC)<sup>\*)</sup>, and other safety regulations.

\*1) ISO 4414: Pneumatic fluid power - General rules and safety requirements for systems and their components  
ISO 4413: Hydraulic fluid power - General rules and safety requirements for systems and their components  
IEC 60204-1: Safety of machinery - Electrical equipment of machines - Part 1: General requirements  
ISO 10218-1: Robots and robotic devices - Safety requirements for industrial robots - Part 1: Robots  
etc.



## **Danger**

**Danger** indicates a hazard with a high level of risk which, if not avoided, will result in death or serious injury.



## **Warning**

**Warning** indicates a hazard with a medium level of risk which, if not avoided, could result in death or serious injury.



## **Caution**

**Caution** indicates a hazard with a low level of risk which, if not avoided, could result in minor or moderate injury.

## **Warning**

### **1. The compatibility of the product is the responsibility of the person who designs the equipment or decides its specifications.**

Since the product specified here is used under various operating conditions, its compatibility with specific equipment must be decided by the person who designs the equipment or decides its specifications based on necessary analysis and test results. The expected performance and safety assurance of the equipment will be the responsibility of the person who has determined its compatibility with the product. This person should also continuously review all specifications of the product referring to its latest catalog information, with a view to giving due consideration to any possibility of equipment failure when configuring the equipment.

### **2. Only personnel with appropriate training should operate machinery and equipment.**

The product specified here may become unsafe if handled incorrectly. The assembly, operation and maintenance of machines or equipment including our products must be performed by an operator who is appropriately trained and experienced.

### **3. Do not service or attempt to remove product and machinery/equipment until safety is confirmed.**

1. The inspection and maintenance of machinery/equipment should only be performed after measures to prevent falling or runaway of the driven objects have been confirmed.
2. When the product is to be removed, confirm that the safety measures as mentioned above are implemented and the power from any appropriate source is cut, and read and understand the specific product precautions of all relevant products carefully.
3. Before machinery/equipment is restarted, take measures to prevent unexpected operation and malfunction.

### **4. Our products cannot be used beyond their specifications. Our products are not developed, designed, and manufactured to be used under the following conditions or environments. Use under such conditions or environments is not covered.**

1. Conditions and environments outside of the given specifications, or use outdoors or in a place exposed to direct sunlight.
2. Use for nuclear power, railways, aviation, space equipment, ships, vehicles, military application, equipment affecting human life, body, and property, fuel equipment, entertainment equipment, emergency shut-off circuits, press clutches, brake circuits, safety equipment, etc., and use for applications that do not conform to standard specifications such as catalogs and operation manuals.
3. Use for interlock circuits, except for use with double interlock such as installing a mechanical protection function in case of failure. Please periodically inspect the product to confirm that the product is operating properly.



# Safety Instructions

## Caution

**We develop, design, and manufacture our products to be used for automatic control equipment, and provide them for peaceful use in manufacturing industries.**

**Use in non-manufacturing industries is not covered.**

Products we manufacture and sell cannot be used for the purpose of transactions or certification specified in the Measurement Act.

The new Measurement Act prohibits use of any unit other than SI units in Japan.

## Limited warranty and Disclaimer/Compliance Requirements

The product used is subject to the following “Limited warranty and Disclaimer” and “Compliance Requirements”.

Read and accept them before using the product.

### Limited warranty and Disclaimer

1. The warranty period of the product is 1 year in service or 1.5 years after the product is delivered, whichever is first.\*2)

Also, the product may have specified durability, running distance or replacement parts. Please consult your nearest sales branch.

2. For any failure or damage reported within the warranty period which is clearly our responsibility, a replacement product or necessary parts will be provided.

This limited warranty applies only to our product independently, and not to any other damage incurred due to the failure of the product.

3. Prior to using SMC products, please read and understand the warranty terms and disclaimers noted in the specified catalog for the particular products.

**\*2) Vacuum pads are excluded from this 1 year warranty.**

A vacuum pad is a consumable part, so it is warranted for a year after it is delivered.

Also, even within the warranty period, the wear of a product due to the use of the vacuum pad or failure due to the deterioration of rubber material are not covered by the limited warranty

### Compliance Requirements

1. The use of SMC products with production equipment for the manufacture of weapons of mass destruction (WMD) or any other weapon is strictly prohibited.

2. The exports of SMC products or technology from one country to another are governed by the relevant security laws and regulations of the countries involved in the transaction. Prior to the shipment of a SMC product to another country, assure that all local rules governing that export are known and followed.

## Operator

- ◆ This operation manual is intended for those who have knowledge of machinery using pneumatic equipment, and have sufficient knowledge of assembly, operation and maintenance of such equipment. Only those persons are allowed to perform assembly, operation and maintenance.
- ◆ Read and understand this operation manual carefully before assembling, operating or providing maintenance to the product.

### ■ Safety Instructions

#### **Warning**

- Do not disassemble, modify (including changing the printed circuit board) or repair.  
An injury or failure can result.
- Do not operate the product outside of the specifications.  
Do not use for flammable or harmful fluids.  
Fire, malfunction, or damage to the product can result.  
Verify the specifications before use.
- Do not operate in an atmosphere containing flammable or explosive gases.  
Fire or an explosion can result.  
This product is not designed to be explosion proof.
- Do not use the product in a place where static electricity is a problem.  
Otherwise it can cause failure or malfunction of the system.
- If using the product in an interlocking circuit:
  - Provide a double interlocking system, for example a mechanical system
  - Check the product regularly for proper operationOtherwise malfunction can result, causing an accident.
- The following instructions must be followed during maintenance:
  - Turn off the power supply
  - Stop the air supply, exhaust the residual pressure and verify that the air is released before performing maintenanceOtherwise an injury can result.

## Caution

- Do not touch the terminals and connectors while the power is on.  
Otherwise electric shock, malfunction or damage to the product can result.
- After maintenance is complete, perform appropriate functional inspections and leak tests.  
Stop operation if the equipment does not function properly or there is a leakage of fluid.  
When leakage occurs from parts other than the piping, the product might be faulty.  
Disconnect the power supply and stop the fluid supply.  
Do not apply fluid under leaking conditions.  
Safety cannot be assured in the case of unexpected malfunction.

## ■ NOTE

- Follow the instructions given below when designing, selecting and handling the product.
- The instructions on design and selection (installation, wiring, environment, adjustment, operation, maintenance, etc.) described below must also be followed.
  - \*Product specifications
    - Use the specified voltage.  
Otherwise failure or malfunction can result.  
Insufficient supply voltage may not drive a load due to a voltage drop inside the Air Catch Sensor.  
Please use the following formula, after verify the operating voltage of the load  
Power voltage - □ Internal drop voltage > Load operating voltage
    - Use the specified operating pressure.  
Otherwise it can cause damage to the Pressure switch or inability to measure correctly.
    - Do not exceed the specified maximum allowable load.  
Otherwise it can cause damage or shorten the lifetime of the Pressure switch.
    - Do not use a load which generates surge voltage.  
When a surge-generating load such as a relay or solenoid is driven directly, use a Pressure switch with a built-in surge absorbing element.
    - Quality of operating air
      1. Use clean air.  
Do not use a fluid containing chemicals, synthetic oils including organic solvent, salt and corrosive gases.  
Otherwise, damage to the product and malfunction can result.
      2. Install an air filter.  
Install the air filter at the up stream side to the valve. Filtration degree should be 5  $\mu$ m or less.
      3. Install an air dryer, after cooler, etc.  
If compressed air containing condensate is used, install an air dryer or drain catch before the filter and perform drainage regularly.
    - Reserve a space for maintenance  
Allow sufficient space for maintenance when designing the system.

## ● Product handling

### \*Installation

- Tighten to the specified tightening torque.
  - If the tightening torque is exceeded the mounting screws and brackets may be broken.
  - If the tightening torque is insufficient, the product can be displaced and loosen the mounting screws.
- Recommended proper torque (Rc, NPT, G) is as below,
  - Connecting thread is 1/8 Torque is 7 to 9 Nm
  - Connecting thread is 1/4 Torque is 12 to 14 Nm
- Eliminate any dust left in the piping by air blow before connecting the piping to the product.
  - Otherwise it can cause damage or malfunction.
- Clean the inside of the pipe of dust or tape sealant when screwing pipes or joints.

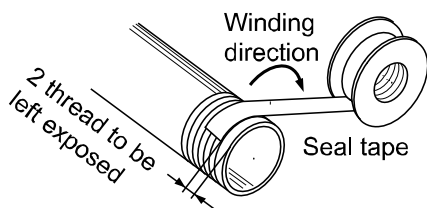

When using tape sealant, leave a couple of screw threads unwrapped with tape sealant.

- Do not insert metal wires or other foreign matter into the pressure measurement port.
  - It can damage the pressure sensor causing failure or malfunction.

### \*Wiring

- Avoid repeatedly bending or stretching the lead wire, or placing heavy load on them.
  - Repetitive bending stress or tensile stress can cause the sheath of the wire to peel off, or breakage of the wire.
  - Replace the damaged lead wire with a new one.
- Wire correctly.
  - Incorrect wiring can break the Pressure switch.
- Do not short-circuit the load.
  - Pay special attention when connecting the positive power supply wire (Brown) and the output wire (Black).
- Do not route wires and cables together with power or high voltage cables.
  - Otherwise the product can malfunction due to interference of noise and surge voltage from power and high voltage cables to the signal line. Route the wires (piping) of the product separately from power or high voltage cables.
- Confirm proper insulation of wiring.
  - Poor insulation (interference from another circuit, poor insulation between terminals, etc.) can lead to excess voltage or current being applied to the product, causing damage.

#### \*Environment

- The enclosure of the switch conforms to IP66 and that for the solenoid valve to IP65. The pressure gauge and the regulator have open constructions. Take poorer protection measures in an environment where water splashes, oil or spatters from welding may adhere to the product.
- Do not operate in locations having an atmosphere of flammable, explosive or corrosive gases, which can result in fire, explosion or corrosion. The Air Catch Sensor does not have an explosion proof rating.
- Do not use in an area where surges are generated.  
If there is equipment which generates a large amount of surge (solenoid type lifter, high frequency induction furnace, motor, etc.) close to the Pressure switch, this may cause deterioration or breakage of the internal circuit of the Pressure switch. Avoid sources of surge generation and crossed lines.
- Mount the product in a place that is not exposed to vibration or impact.  
Otherwise failure or malfunction can result.
- Please consult with SMC if the product is to be energized continuously for long periods of time.
- Keep within the specified fluid and ambient temperatures range.  
The fluid and ambient temperatures is 0 to 60 °C. Operation under low temperature (5 °C or less) leads to cause damage or operation failure due to frozen moist in the fluid or air.  
Otherwise malfunction can result.  
Protection against freezing is necessary. air dryer is recommended for elimination of drain and water.  
Avoid sudden temperature change even within specified temperature.
- Do not operate close to a heat source, or in a location exposed to radiant heat.  
Otherwise malfunction can result.

#### \*Maintenance

- Turn off the power supply, stop the supplied air, exhaust the residual pressure and verify the release of air before performing maintenance.  
There is a risk of unexpected malfunction.
- Perform drainage regularly.  
If condensate enters the secondary side, it can cause operating failure of pneumatic equipment.
- Do not use solvents such as benzene, thinner etc. to clean the Pressure switch.  
They could damage the surface of the body and erase the markings on the body.  
Use a soft cloth to remove stains. For heavy stains, use a cloth soaked with diluted neutral detergent and fully squeezed, then wipe up the stains again with a dry cloth.



## ■Precautions (Air Catch Sensor ISA2 Series)

### ●Product handling

#### \*Installation

- If the detection nozzle is exposed to splashes of water or cutting oil, do not allow backflow from the detection nozzle to the switch body. Install the switch body at a position higher than the detection nozzle wherever possible.
- In the piping between the switch body and the detection nozzle, do not use equipment or fittings that can possibly cause leakage or serve as resistance.  
Do not use One-touch fittings in an environment where the Air Catch Sensor is exposed to water or other liquid.
- Since steel piping lacking flexibility is easily affected by moment loads or propagation of vibration, employ flexible tubing, etc., to prevent interactions of such factors.

#### \*Environment

- When an Air Catch Sensor is contained in a box, provide an air outlet to constantly keep the atmospheric pressure inside the box.  
Internal pressure rises will hinder normal air discharge and may lead to possible malfunction.
- The air outlet is provided on the setting dial section of the Air Catch Sensor. Do not turn off air supply to the switch if water or cutting oil splashes around the setting dial.
- Since the orifice of the Air Catch Sensor is small, prevent foreign matter from entering the equipment.  
For this purpose, use supply air that is dry and filtered 5 mm or better.
- Since the product adopts a semiconductor pressure sensor, keep the operating pressure not larger than 0.2 MPa.
- Although CE accredited, this Air Catch Sensor is not equipped with surge protection against lightning.  
Necessary counter-measures for possible lightning surge should be fitted to system components as required.

## ■Precautions (2 Port Solenoid Valve VCA Series)

### ●The instructions on design and selection

- Take special precautions if a resistor is used in parallel with the switching element or a C-R element (for surge voltage protection) is used for protection of the switching element. The valve may fail to turn off due to leakage current flowing through the resistor or C-R element.

AC coil: 10% or less of rated voltage

DC coil: 2% or less of less of rated voltage

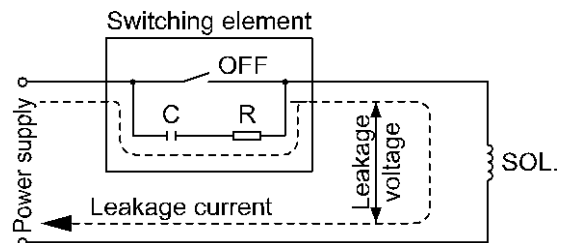

### ●Product handling

#### \*Installation

- Do not use the Air Catch Sensor if the leakage amount increases or the equipment does not operate properly.  
After installation, connect compressed air and electricity and conduct an appropriate functionality inspection to confirm that the Air Catch Sensor is installed properly.
- Do not apply external force to the coil.  
Apply a wrench to the exterior surface of the piping joint at the time of tightening.
- Do not use heat insulators, etc. to keep the temperature at the coil assembly.  
Do not use a tape heater for freeze prevention except on the piping and body. It may cause the coil to burn.

#### \*Wiring

- Used electrical wires with a conductive sectional area of 0.5 to 1.25 mm<sup>2</sup>. Make sure that no excessive force is applied to the wires.
- Adopt an electrical circuit which will not cause chattering at the contact.
- The voltage variation must stay within the -10 to +10% range of the rated voltage. In case importance is attached to response characteristics due to use of a DC power source, keep the variation within the -5 to +5% range. The voltage drop is the value at the lead wire to which the coil is connected.

\*Electrical connection for solenoid valve

**DIN connector**

Since internal connections are as below for the DIN connector, make connections to the power supply accordingly.

Terminal No.	1	2
DIN terminal	+ (-)	- (+)

\*: There is no polarity.

- Use compatible heavy duty cords with cable O.D. φ6 to 12.
- Use the tightening torque below for each section.

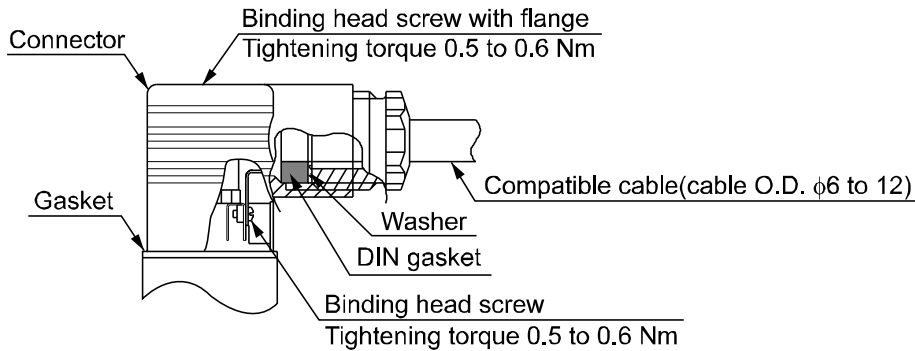
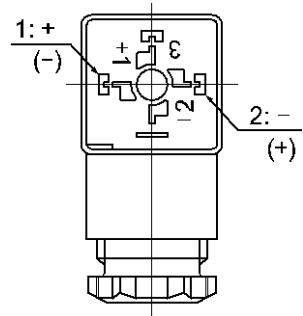

\*: Use after remove inner of DIN gasket in case of cable O.D. is φ9 to 12.

**Conduit terminal**

In the case of the conduit terminal, make connections according to the marks shown below.

- Use the tightening torque below for each section.
- Properly seal the terminal connection (G1/2) with the special wiring conduit, etc.

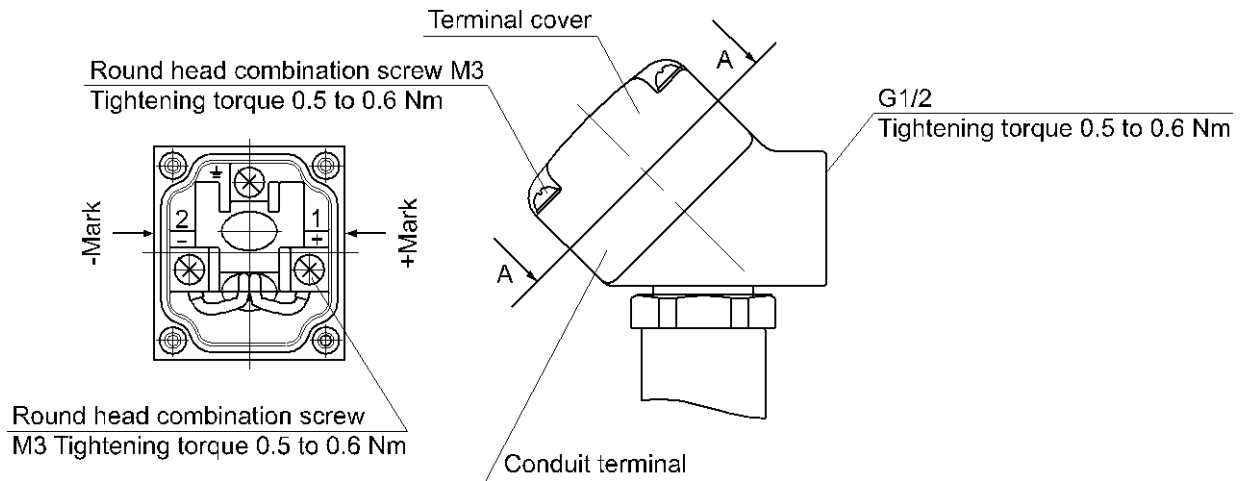

View A-A  
(Internal connection diagram)

**\*Maintenance**

- Perform regular maintenance and inspections.  
There is a risk of unexpected malfunction.
- Perform valve switching at least every 30 days to prevent malfunction. Also, conduct a periodic inspection at intervals of approximately 6 months to use the product in its best condition.
- Perform drainage regularly.  
If condensate enters the secondary side, it can cause operating failure of pneumatic equipment.

**\*Assembly and disassembly the valve**

- Before disassembling, shut down the power supply and air pressure supply, and release the residual pressure.
- Disassembly procedure
  1. Remove the top mounting screws.
  2. Remove the solenoid coil, spring, and armature assembly.
  3. If there is any foreign matter adhering on the surface, take appropriate measures to clear it off such as an air blow or washing with neutral detergent.

**•Assembly procedure**

- Reverse the above procedure to assemble the product.  
In case the electrical entry is changed, also change the mounting orientation of the solenoid coil before assembly.
- \*: Tighten the 4 mounting screws by each pair of corners on a diagonal line at the proper tightening torque (0.4 to 0.5 Nm)

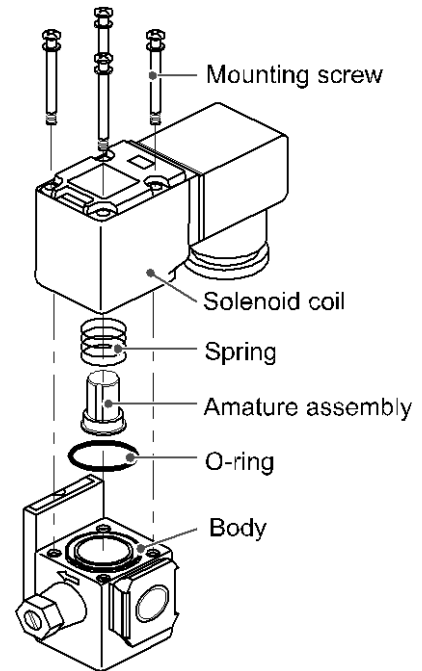

**■Precautions (Regulator AR Series)**

**●Product handling**

**\*Installation**

- The adjustment knob must be handled manually. Use of tools may cause damage to the product.
- Check the inlet and outlet pressure indications on the pressure gauge while setting. If the knob is turned to excess, it may cause internal parts to fracture.
- Since products for 0.02 to 0.2 MPa settings come with a pressure gauge for 0.2 MPa, do not apply pressure exceeding 0.2 MPa. It may cause damage to the pressure gauge.
- Unlock the knob before pressure adjustment and lock it again when the adjustment is over.  
Incorrect procedure may cause damage to the knob or lead to the outlet pressure fluctuation.
- Pull the adjustment knob to release the lock. An orange colored line is provided at the bottom of the adjustment handle for visual checking.
- Push the pressure regulation knob to engage the lock. If it does not lock easily, turn the knob slightly clockwise or counterclockwise until the orange colored line goes out of sight.
- When the product is installed, leave a space of 60 mm on the side of the valve guide (opposite to the knob) for maintenance and inspection.

# Model Indication and How to Order

Without control unit IISA2 N **PR**-**1**

With Control unit IISA2 **C****SL**-**6****5****D****E2**

Control unit

C	Regulator + 2 port solenoid valve
V	2 port solenoid valve

Station  
1 to 6

Electrical entry and porting position

SR	Concentrated wiring, right side
SL	Concentrated wiring, left side
PR	Discrete wiring, right side
PL	Discrete wiring, left side

\*: The porting position depends on the R/L side from the front side of switch.

Option

NIL	Without bracket
B	With bracket
D	With DIN rail

Voltage for 2 port solenoid valve

1	100 VAC
2	200 VAC
3	110 VAC
4	220 VAC
5	24 VDC
6	12 VDC
36	230 VAC

Gauge for regulator \*

*A	Without gauge *2	
E2	0.2 MPa	Square (MPa)
G2		Round (MPa)
*P2	0.2 MPa	Round (Dual indication MPa and psi)
*Z2		Square (psi)
E4	0.4 MPa	Square (MPa)
G4		Round (MPa)
*P4	0.4 MPa	Round (Dual indication MPa and psi)
*Z4		Square (psi)

\*: Made to Order

\*1: psi unit is not available in japan because of new measurement law.

\*2: Pressure gauge mounting screw is 1/8.

Restrictor + manual lock

NIL	Without restrictor and manuallock
C	With restrictor and without manuallock
M	Without restrictor and manuallock
W	With restrictor and manuallock

Electrical entry for 2 port solenoid valve

D	DIN connector
DL	DIN connector (With lamp)
DO	DIN connector (Without connector)
T	Conduit terminal
TL	Conduit terminal (With lamp)

\*: It is not possible to order only without control unit and with control unit.

Specifying increase stations

ISA2-**G** **□** **E2** **1** **□**

Sensing distance

G	0.25 mm
H	0.5 mm

Port size

Nil	Rc1/8
N	NPT1/8
*F	G1/8

\*: Made to Order

Electrical entry

Discrete	Nil	Straight
	*L	Light angle
	N	Without lead wire
Concentrated	P	Terminal box

\*: Made to Order

Output

1	NPN
5	PNP

Gauge \*1

*A	Without gauge *2	
E2	0.2 MPa	Square (MPa)
G2		Round (MPa)
*P2	0.2 MPa	Round (Dual indication MPa and psi)
*Z2		Square (psi)
E4		Square (MPa)
G4	0.4 MPa	Round (MPa)
*P4		Round (Dual indication MPa and psi)
*Z4		Square (psi)

\*: Made to Order

\*1: psi unit is not available in japan because of new measurement law.

\*2: Pressure gauge mounting screw is 1/8.

# Summary of Product parts

## Names of individual parts

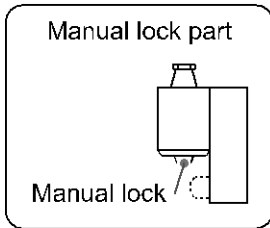
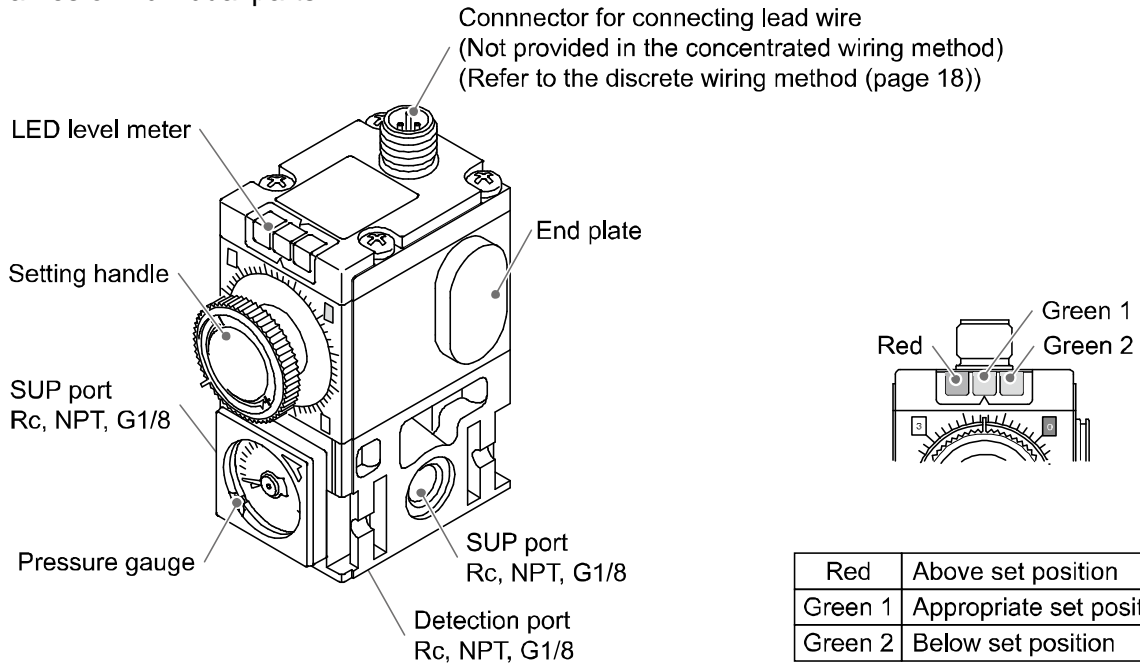

Terminal board box  
(Refer to the concentrated wiring method  
(page 18))

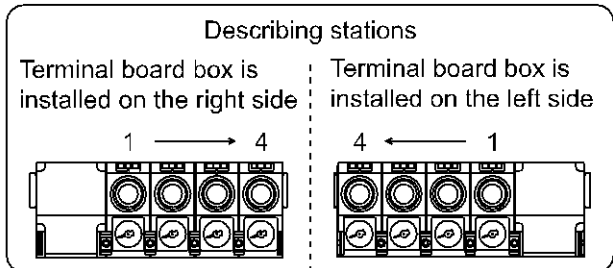
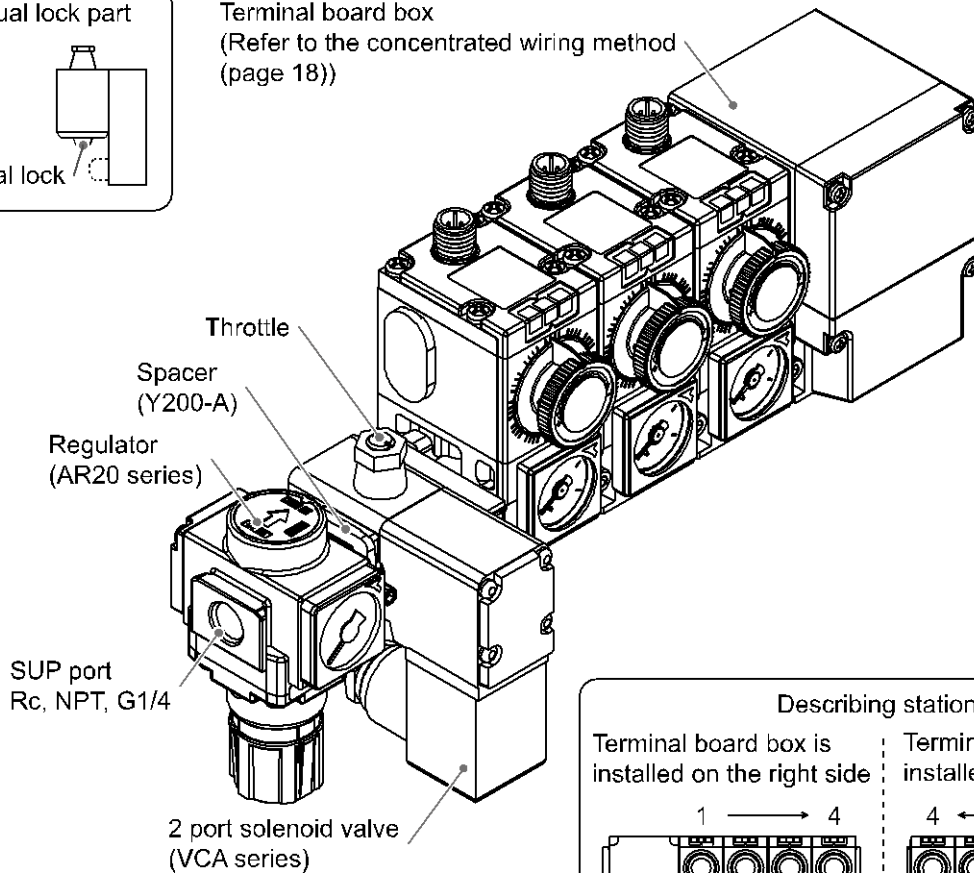

## ■ Definition and terminology

	Terms	Meaning
D	Detection range	Distance at which an instrument such as the Air Catch Sensor is operational.
	Deviation level indicator light	The indicator light which shows how much the current value differs from the setting value in Air Catch Sensor.
H	Hysteresis	Difference between the points at which the Pressure switch is turned on and off.
I	Indication light	The light that turns on when the switch output is on.
	Insulation resistance	Insulation resistance of a product itself. The resistance between an electric circuit and a body.
M	Max. applied voltage	The maximum value of applied voltage available to the output line of the NPN output.
	Max. load current	The maximum current available to the output (output line) of the switch output.
N	NPN (open collector) (output)	The switch that uses the NPN transistor for output.
O	Operating pressure range	Pressure range. The unit was designed to operate in.
	Orifice	Restriction for controlling flow of fluid.
P	Piping-port size	The size of the port on the switch body with which a device and the switch are connected.
	PNP (open collector) (output)	The switch that uses the PNP transistor for output.
	Pressure setting	The setting of pressure to determine the point at which the Pressure switch turns on and off.
	Repeatability	Reproducibility of the displayed value for pressure and ON-OFF output operating point when the pressure changes at a temperature of 25 °C.
	Residual voltage	The difference between the ideal ON voltage and the actual voltage when the switch output is on. It depends on present load current and ideally should be "0".
	Response time	The elapsed time until the ON-OFF output begins working since the pressure supplied for the Pressure switch has reached the set value. Generally, the shorter response time is, the better the performance is.
	Ripple	A type of chattering.
V	Voltage resistance	Durability to voltage applied between an electric circuit and a body. A product's durability in withstanding voltage. If more voltage is applied to the product, the product may be broken. (Voltage mentioned here is not power voltage to activate the product.)

# Mounting and Installation

## Manifold expansion

### 1. Disassemble

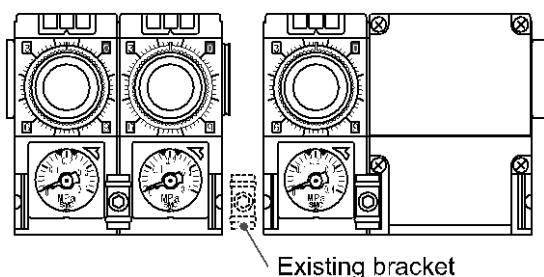

1. Loosen the screws and dismount two brackets one each front and back surface.
2. Split the switch slowly so as not to disengage the O-ring of the SUP port.

### 2. Insert

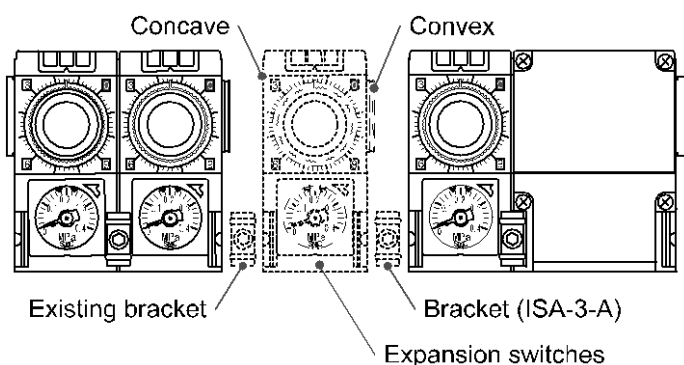

1. Set the expansion packing (ISA-7-B) in the concave of the SUP port for expansion switches.
2. Mount the convex of the expansion switch onto the existing switch.
3. Mount the two brackets (ISA-3-A) to their positions.  
\*: Fasten the screws temporarily.
4. Make sure that an expansion packing is set in the concave of the existing switch SUP port.
5. Fit the convex of the existing switch onto the concave of the added switch.
6. Mount the existing bracket.  
\*: Fasten the screws temporarily.

### 3. Tightening

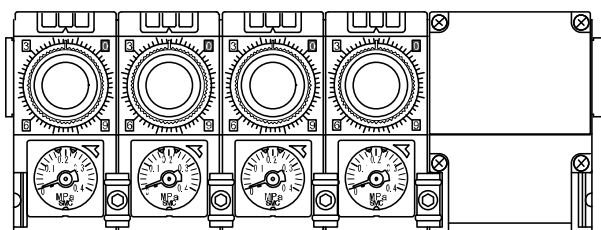

1. Tightening the fasteners by specified torque 1.2 Nm.
2. Install air pipe and confirm that there is no air leakage from air pipe installed additionally

### How to remove the end plate

It can remove by hooking a finger on the slot for removal on up-and-down, and pulling horizontally.

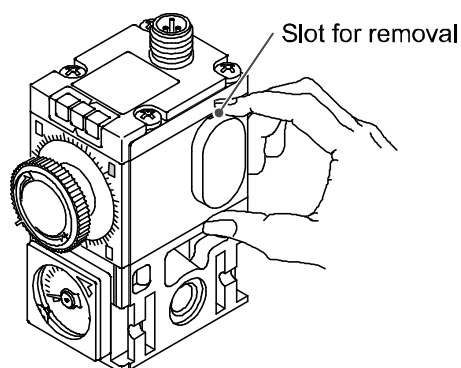



○Circuit and wiring for Air Catch Sensor

•Circuit and wiring for Air Catch Sensor

•NPN open collector output

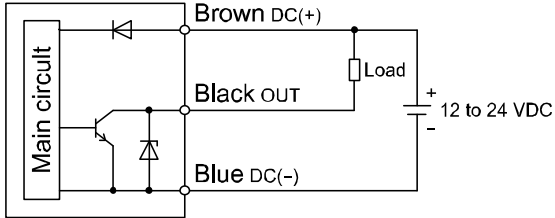

•PNP open collector output

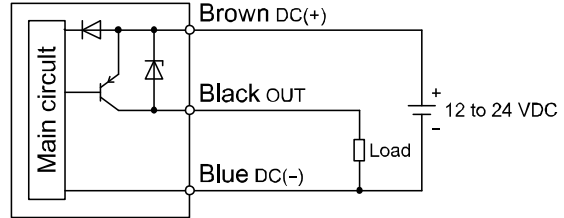

•Circuit and wiring for 2-port solenoid valve

•Without indicator lamp DC circuit

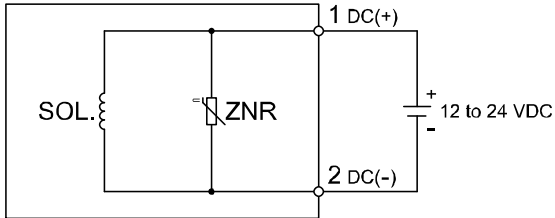

•Without indicator lamp AC circuit

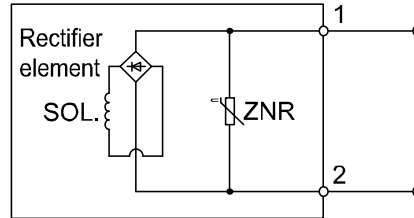

•Conduit terminal  
Indicator lamp provided DC circuit

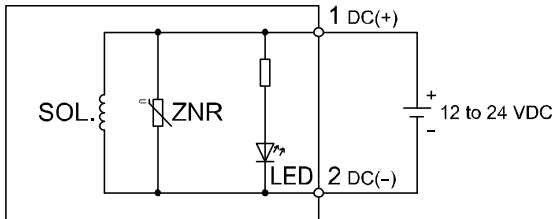

•Conduit terminal, DIN connector  
Indicator lamp provided AC circuit

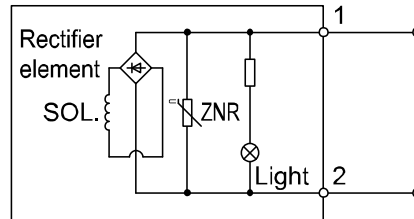

•DIN connector  
Indicator lamp provided DC circuit

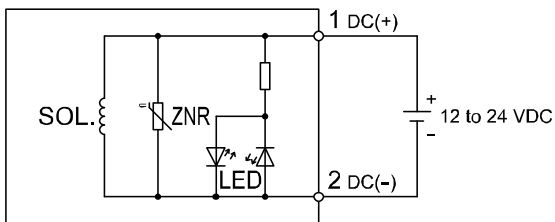

See the catalog and operation manual of SMC VCA series for the wiring method of circuit and wiring for 2-port solenoid valve.

Do not apply incorrect power supply voltage to wiring. Incorrect power supply voltage may damage the equipment.

## ■Wiring

### ○Discrete wiring method

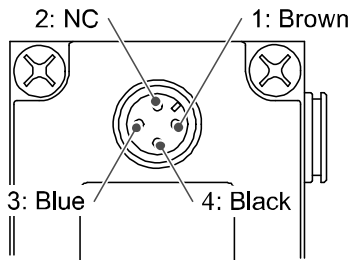

1	Brown	DC(+)
2	-	NC
3	Blue	DC(-)
4	Black	OUT

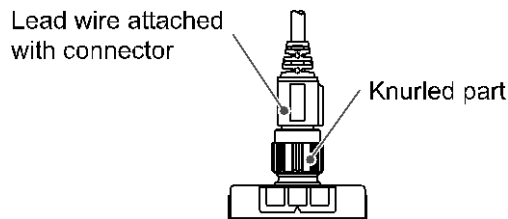

1. Insert the lead wire attached with a connector into the key groove.
2. Hold the knurled part by two fingers and turn it clockwise to tighten it. Stop tightening if two fingers become painful when tightening.
3. Install wires of various colors coming out from the end of the cable. Install wires correctly while seeing the circuit diagram and the left table.

### ○Concentrated wiring method

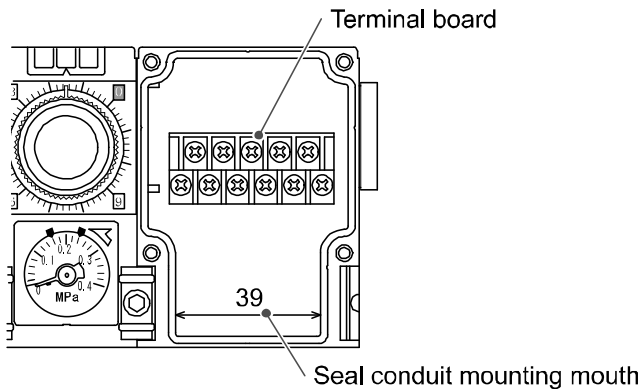

1. Mount the seal conduit on the terminal board box. See the catalog and operation manual of the seal conduit manufacturer for the method to mount the seal conduit.
2. Insert the cable through the seal conduit and install the wires matching the polarities of the terminal board illustrated left.
3. Tighten the seal conduit. Do not hold down the terminal board box or switch while tightening the seal conduit. Tightening torque shall be less than 5 Nm.

OUT	OUT	OUT	OUT	OUT
1	2	3	4	5
⊗	DC (-)	DC (+)	NC	OUT 6

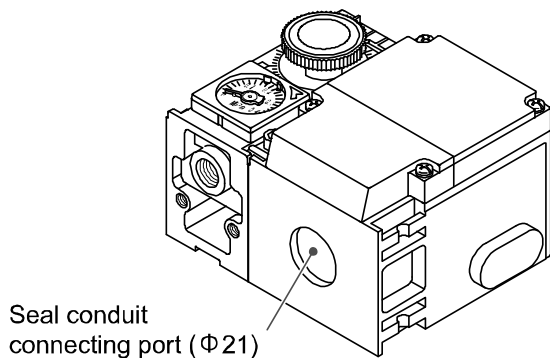

## ■ Setting

Set the detectable distance by the LED level meter and setting handle.

While setting, pull out the setting handle illustrated below.

Removing the hand off the setting handle will reset the setting handle condition before it is pulled out and the handle can no longer be turned.

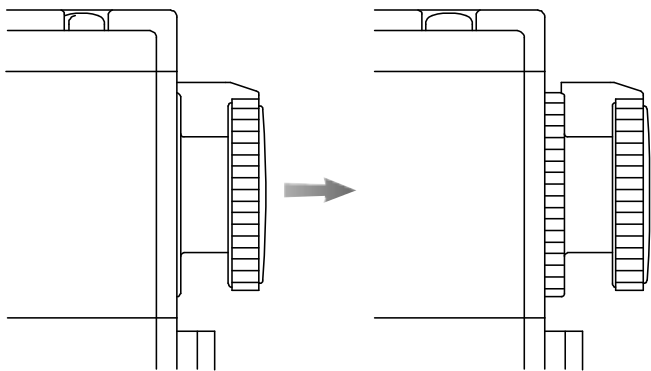



Before pulling out

Setting handle pulled out

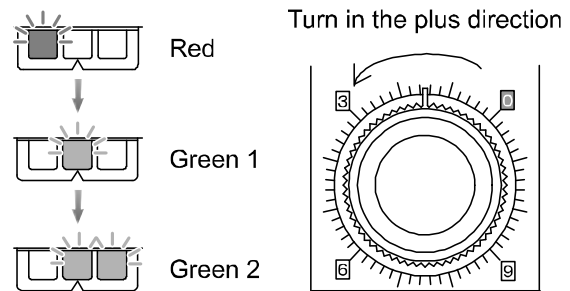
1. Apply a thickness gauge onto the detection nozzle and set a setting state for accurate setting.
2. Confirm that supply pressure is applied. If the setting handle is fully closed,  will light off.
3. Pull the setting handle and turn in the plus direction will light up in this order.



4. When  on the LED level meter lights up, the sensor output turns ON. Finish setting when  lights up.
5. Apply a thickness gauge again and check that  lights up.

### ○ Handling and setting of 2-port solenoid valve

Throttle setting for blowing to prevent water, cutting fluid or other liquid from entering the nozzle.

Clockwise: Throttle close

Counterclockwise: Throttle open

\*: The setting is not required if the valve of your sensor does not have a throttle.

1. Turn the power of the valve off.
2. Adjust the throttle turning clockwise so that water, cutting fluid or other liquid is not flung up from the detection nozzle.
3. Turn the power of the valve on, then turn the power OFF again. Confirm that water, cutting fluid or other liquid is not flung up from the detection nozzle.

\*: Do not rotate more than 5 times from fully closed condition since the orifices is pulled out.

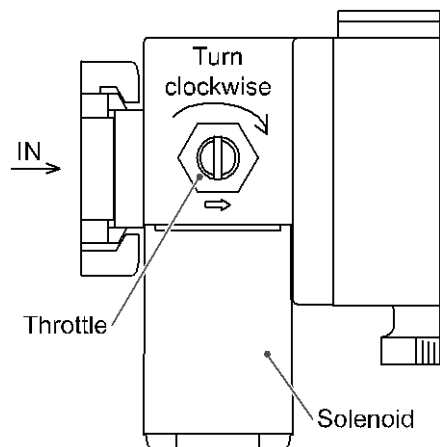

○Manual operation

Slotted locking type (Tool required)

Valve opening: Turn the screw 90 clockwise using a slotted screwdriver. The valve remains open even when the screwdriver is removed.

Valve closing: Turn the screw 90 anticlockwise from a valve open position to its original position.

Make sure that the screw is in a valve closed position in case of electric operation.

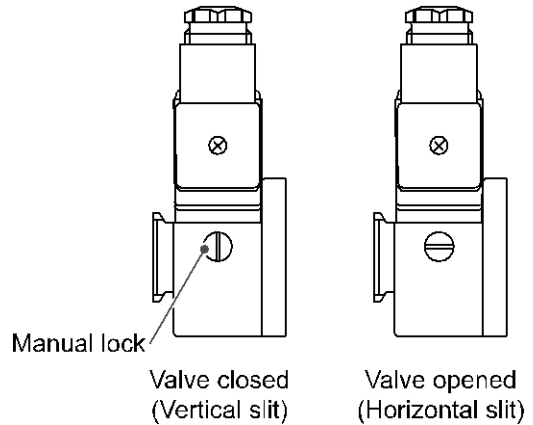

○Handling and setting of limit gauge indicator

1. Cover Dismounting

Hold the edge of the front cover by fingers and turn the cover in the OPEN arrow direction till it stops (15°). Pull the cover in front direction to dismount it.

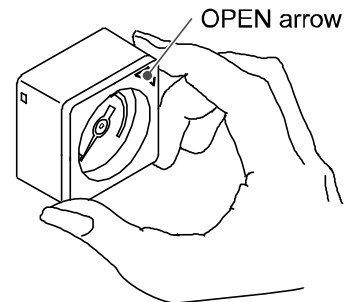

2. Installing referential Needles

Move an referential needle by a fingertip. Adjust high and low limits of pressure by two green referential needles.

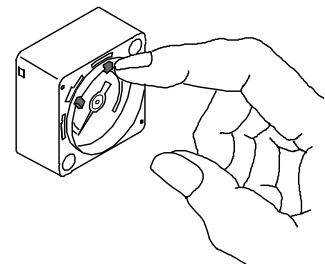
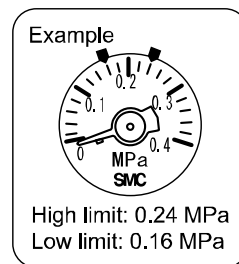

3. Cover Mounting

After finishing setting the referential needles, mount the cover back to its original position. Insert the cover pin into the hole in the case (mark ▲ in enlarged view of part A) and turn it clockwise till it stops. (Direction opposite the OPEN arrow direction) Confirm that the cover is hold securely.

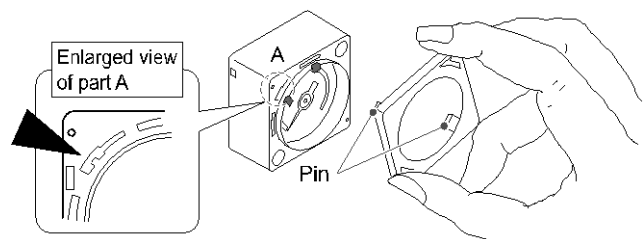

## ■ Designing data

### ○ Nozzle diameter and detection distance

The graphs below shows the hysteresis in relationship to the detection distance.

When high accuracy is required, design the system so the hysteresis is within the 0.01 mm detection distance.

When the Hysteresis exceeds 0.01 mm use the Air Catch Sensor as a confirmation of position of work piece.

#### ISA2-G □ □ □ □

Detection nozzle:  $\phi 1.5$

Detection side piping:  $\phi 6 \times \phi 4$  tubing 5 m

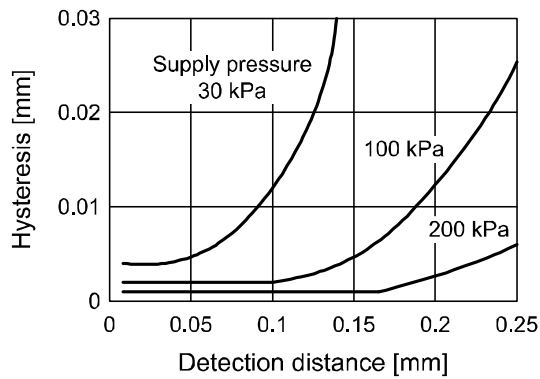

#### ISA2-H □ □ □ □

Detection nozzle:  $\phi 2.0$

Detection side piping:  $\phi 6 \times \phi 4$  tubing 5 m

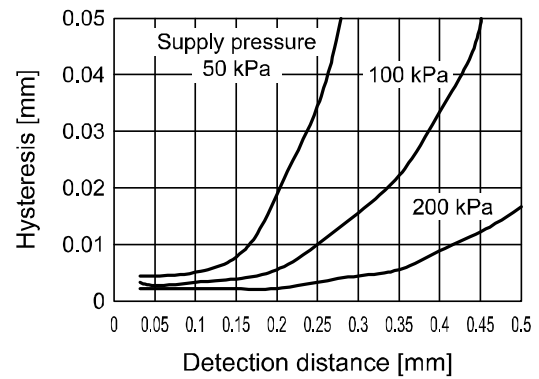

○Response time

The response time is dependent on the detection distance and the piping length.

The above figures show the response time for different detection distance settings and a constant piping length. The below figures show the response time when the detection distance is constant but the piping length changes. As can be seen from the graphs below, if the piping length is kept short and the detection distance is small, the response time is faster.

**ISA2-G□□□□**

Detection nozzle:  $\phi 1.5$   
 Detection side piping:  $\phi 6 \times \phi 4$  tubing 5 m  
 Supply pressure: 100 kPa

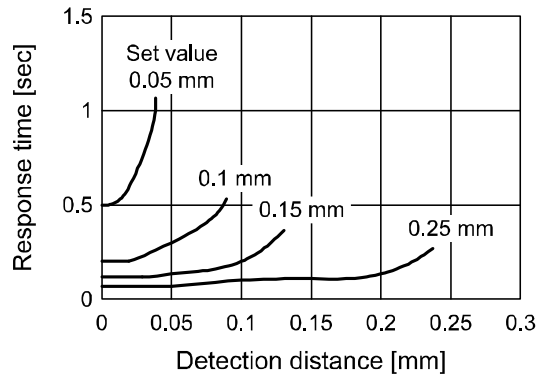

Detection distance-Response time characteristics

**ISA2-H□□□□**

Detection nozzle:  $\phi 2.0$   
 Detection side piping:  $\phi 6 \times \phi 4$  tubing 5 m  
 Supply pressure: 100 kPa

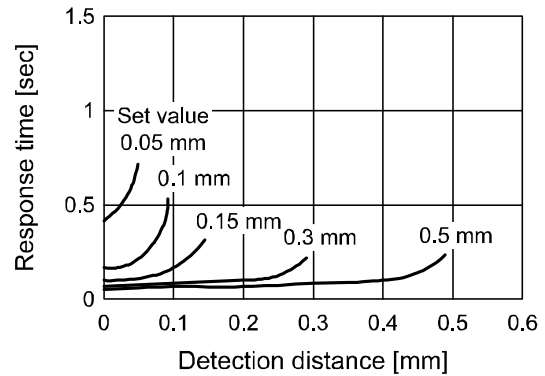

Detection distance-Response time characteristics

Detection nozzle:  $\phi 1.5$   
 Detection side piping:  $\phi 6 \times \phi 4$   
 Supply pressure: 100 kPa  
 Set distance: 0.15 mm

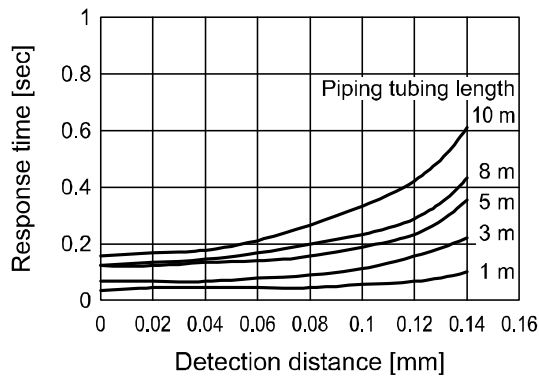

Piping tubing length-Response time

Detection nozzle:  $\phi 2.0$   
 Detection side piping:  $\phi 6 \times \phi 4$   
 Supply pressure: 100 kPa  
 Set distance: 0.3 mm

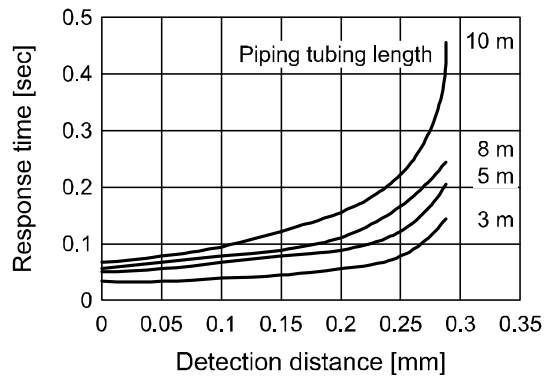

Piping tubing length-Response time

○Supply pressure vs. detection distance

The graphs below show the detection distance for different supply pressure setting.

**ISA2-G□□□□**

Standard pressure: 100 kPa  
 Detection nozzle:  $\phi 1.5$   
 Detection side piping:  $\phi 6 \times \phi 4$  tubing 5 m

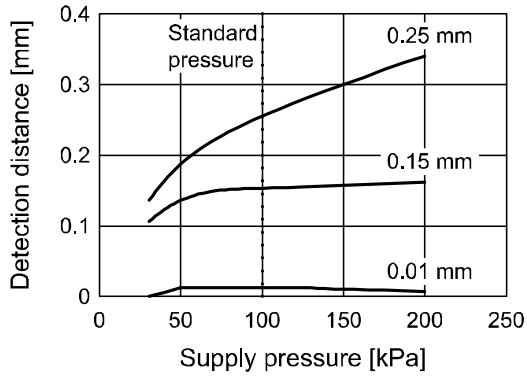

**ISA2-H□□□□**

Standard pressure: 100 kPa  
 Detection nozzle:  $\phi 2.0$   
 Detection side piping:  $\phi 6 \times \phi 4$  tubing 5 m

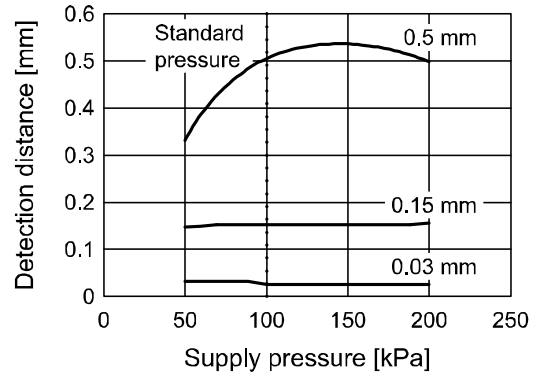

# Troubleshooting

## ○Troubleshooting

Applicable Pressure switch: **ISA2**

If a cause applicable to the failure cannot be identified and normal operation can be recovered by replacement with a new Pressure switch, this indicates that the Pressure switch itself was broken. The Pressure switch breakage can be caused by operating environment (network construction, etc.), and so consult with SMC separately to obtain countermeasures.

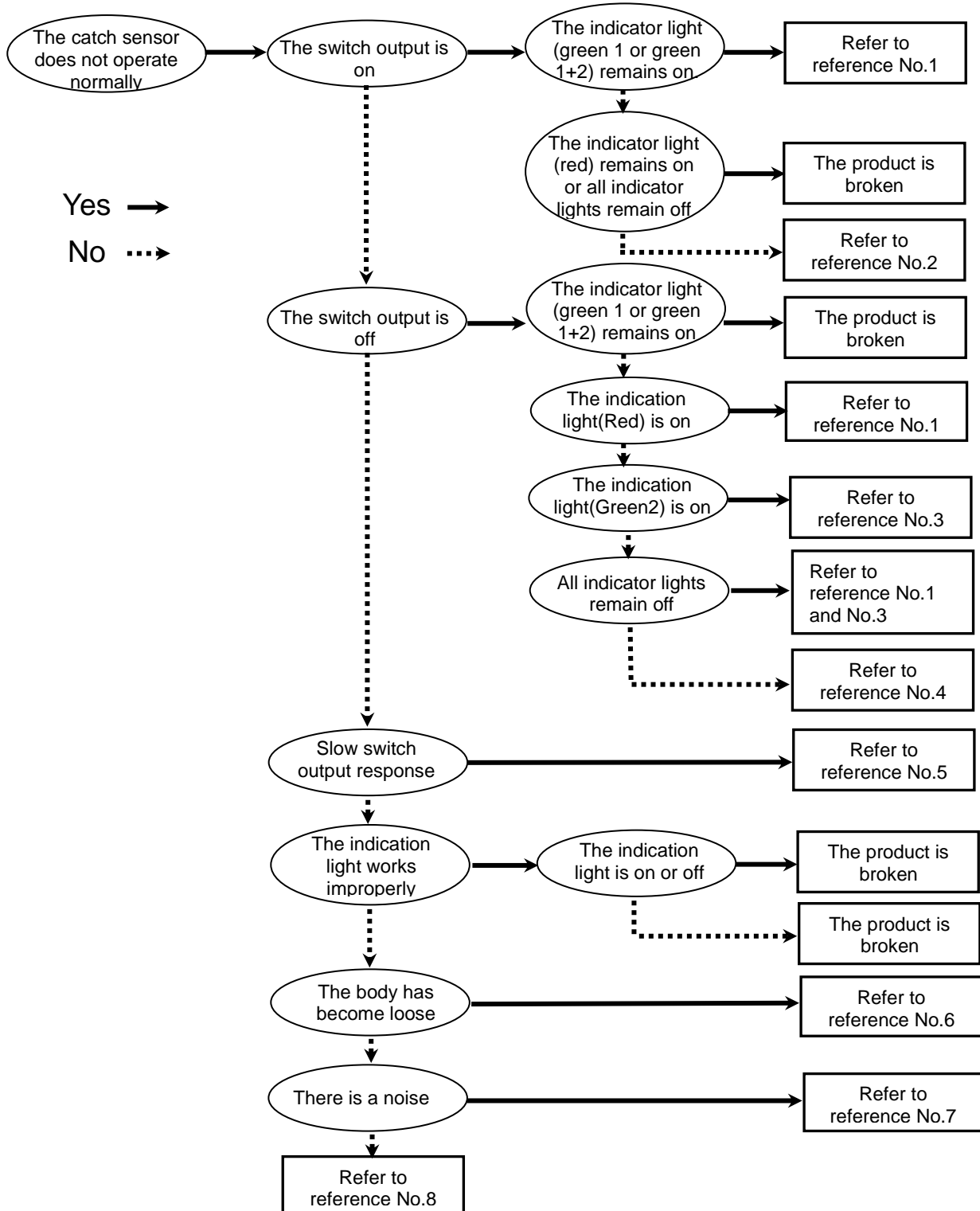



○Cross-reference for troubleshooting

Reference No.	Problem	Possible cause	Investigation method	Countermeasure
1	Output remains on. Indication light remains on.  Output remains off. Indication light remains off.	Incorrect setting of detection distance	Check the set detection distance.	Reset the detection distance.
		Product failure		Replace the product.
2	Output remains on. Indication light works correctly.	Incorrect wiring	Check the wiring of the output line. Check if the load is connected directly to DC(+) or DC(-).	Correct the wiring.
		Product failure		Replace the product.
3	An over current error is indicated.	Over current to the output	(1) Check if a current of 80 mA or more is flowing to the output.	(1), (2) connect the load as specified.
			(2) Check if the connected load satisfies the specifications, and if the load is shorted.	
			(3) Check if a relay without a surge voltage suppressor is connected.	(3) Use a relay with a surge voltage suppressor or take a measure to prevent noise.
			(4) Check if the wiring is in the same route as (or bundled together with) a high-voltage line or the power line.	(4) Separate the wiring from the high-voltage line and/or power line.
4	Output remains off. Indication light works correctly.	Incorrect wiring	Check the wiring of the output line. Check if the load is connected directly to DC(+) or DC(-).	Correct the wiring.
		Unsuitable model selection	Check if PNP is used even though NPN should have been selected, or the other way around.	Review the selected model (output type).
		Lead wire breakage	Check if there is bending stress applied to any parts of the lead wire. (Bending radius and tensile force applied to the lead wire)	Correct the wiring conditions. (Adjust the tensile force and widen the bending radius.)
		Product failure		Replace the product.
5	Slow switch output response	Incorrect setting of detection distance	Check if the set detection distance is the same as (or close to) the actual detection distance.	Reset the detection distance so that it is further from the actual detection distance.
6	The body is loose.	Incorrect installation	Check correct mounting of the bracket and DIN rail.	Correct the wiring.
		Product failure		Replace the product.

Reference No.	Problem	Possible cause	Investigation method	Countermeasure
7	Noisy.	Air and liquid leakage	Check if air liquid are leaking from the piping.	Rework the piping. If excessive tightening torque over the specified range is applied, a mounting screw, mounting bracket, and product may be broken.
		Product failure		Replace the product.
8	The operation is unstable.	Incorrect wiring/ lead wire breakage	(1) Check the power supply wiring. (2) Check if bending stress is applied to a specific part of the lead wire. (bending radius and tensile force applied to the lead wire)	(1) Correct the wiring (2) Correct the wiring conditions. (Adjust the tensile force and widen the bending radius.)
		Product failure		Replace the product.

# Specification

## ■ Specifications

Model No.		ISA2-G□□1□	ISA2-G□□5□	ISA2-H□□1□	ISA2-H□□5□
Detection zone		0.01 to 0.25 mm		0.03 to 0.50 mm	
Fluid		Dry air (Filtered through a 5 μm filter)			
Operating pressure range		30 to 200 kPa		50 to 200 kPa	
Detection nozzle size		φ1.5		φ2.0	
Flow consumption L/min (ANR)	Supplied pressure	50 kPa	5 or less	10 or less	
		100 kPa	8 or less	15 or less	
		200 kPa	12 or less	22 or less	
Power supply voltage		12 to 24 VDC±10%, ripple (p-p) 10% or less (Protected against inverse connection)			
Current consumption		15 mA or less			
Switch output		NPN open collector	PNP open collector	NPN open collector	PNP open collector
		Max. load current			
		80 mA			
		Max. applied voltage			
		30 V (NPN output)			
		Residual voltage			
		1.5 V or less (80 mA load current)			
		Output protection			
		Short Circuit Protection			
Repeatability (including temp. characteristics)		0.01 mm or less (Detection distance range 0.01 to 0.15 mm, Supply pressure 100 to 200 kPa)		0.01 mm or less (Detection distance range 0.03 to 0.15 mm, Supply pressure 100 to 200 kPa)	
Hysteresis *1		0.01 mm or less (Detection distance range 0.01 to 0.15 mm)		0.01 mm or less (Detection distance range 0.3 to 0.15 mm)	
Indicator light		LED level meter (Red: 1, Green: 2) (Set value < Actual distance: Red, Set value = Actual distance: Green 1, Set value > Actual distance: Green 1 + Green 2)			
Environment	Enclosure	IP66: without pressure gauge IP40: with pressure gauge			
	Ambient temperature	Operation: 0 to 60 °C, Storage: -20 to 70 °C (No condensation or freezing)			
	Ambient humidity	Operation, Storage: 35 to 85 %RH (No condensation)			
	Withstand voltage	1000 VAC 50/60 Hz, 1 minute Between lead block and case			
	Insulation resistance	2 MΩ□ or more at 500 VDC Between lead block and case			
Port size		NIL: Rc1/8 N: NPT1/8 F: G1/8			
Lead wire (for independent wiring)		For M12 with 4 pin pre-wired connector, 4-core oil proof cable (0.64 mm <sup>2</sup> ), 5 m			
Terminal board box (for common wiring)		Front (Electrical entry size φ21)			
Weigh		Individual wiring (only body): 253 g, Centralized wiring (only body): 250 g, Terminal box: 205 g, Lead wire: 278 g, Joint bracket + Seal for adding station: 4 g			

\*1: Refer to the graph "Nozzle Diameter and Detection Distance" for hysteresis.

\*2: Refer to "Setting" for the LED level meter.

## ■Dimensions

- Discrete wiring method
- With bracket

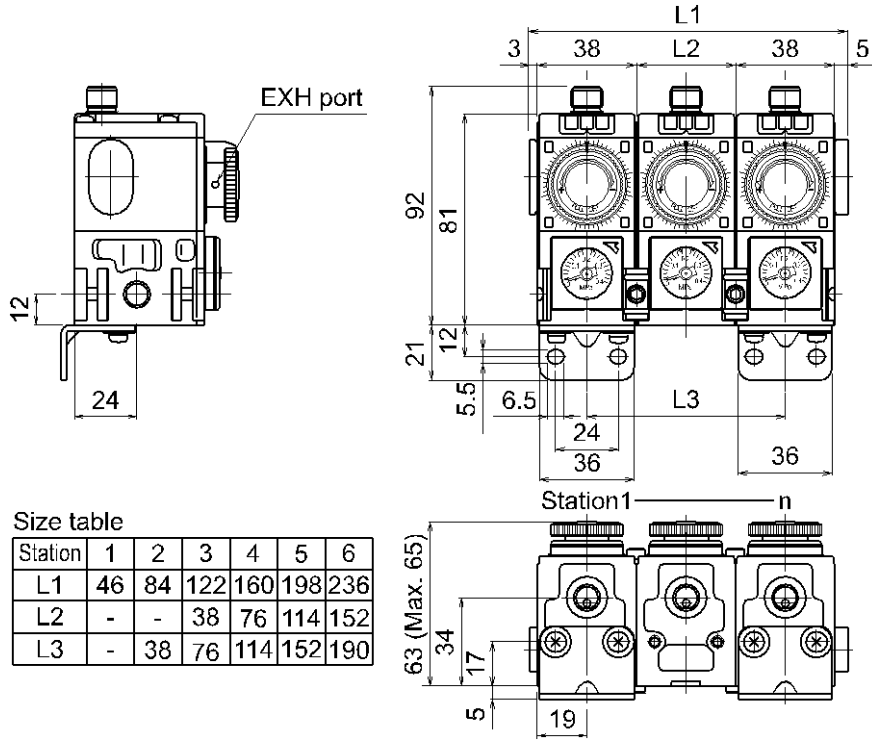

- With DIN rail

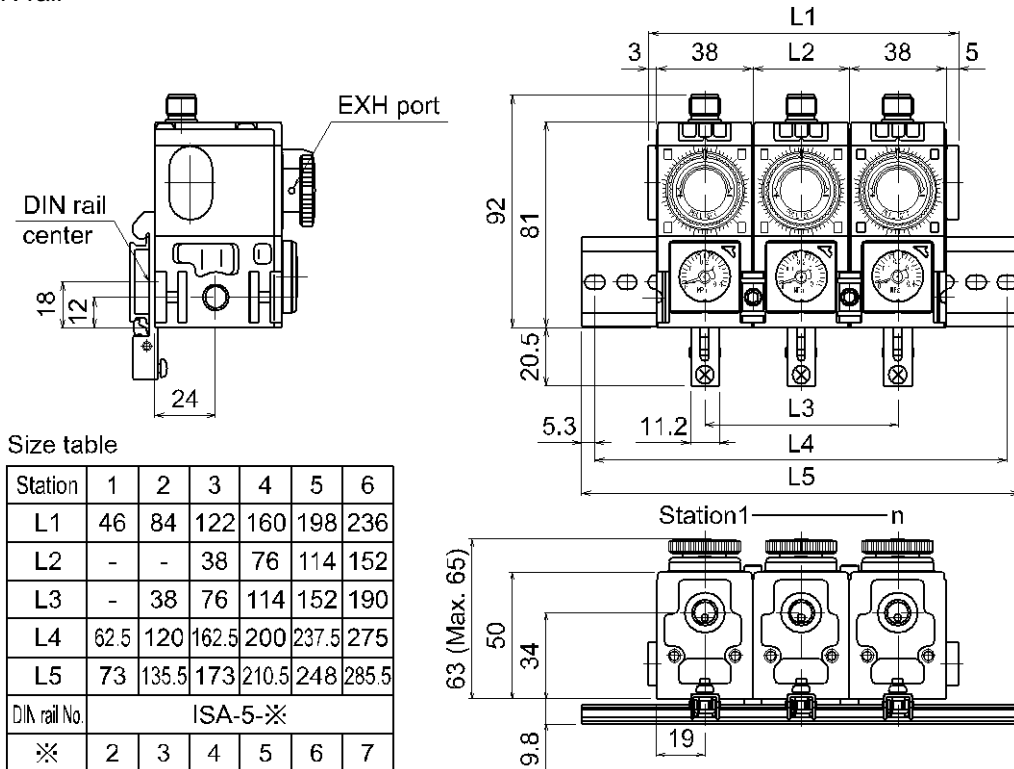

○ Concentrated wiring method

● With bracket

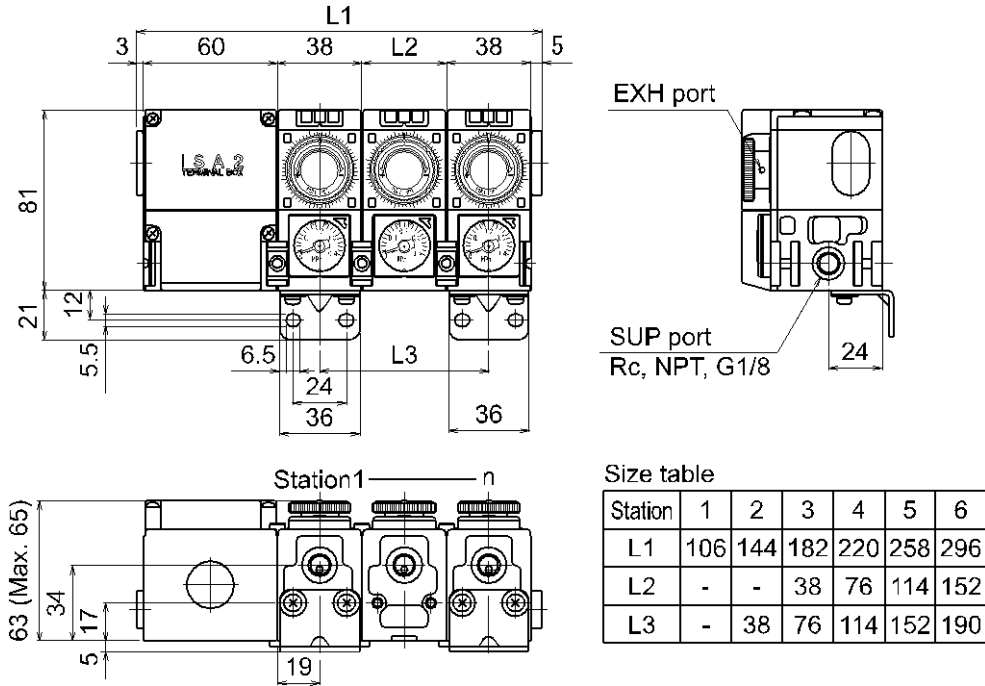

● With DIN rail

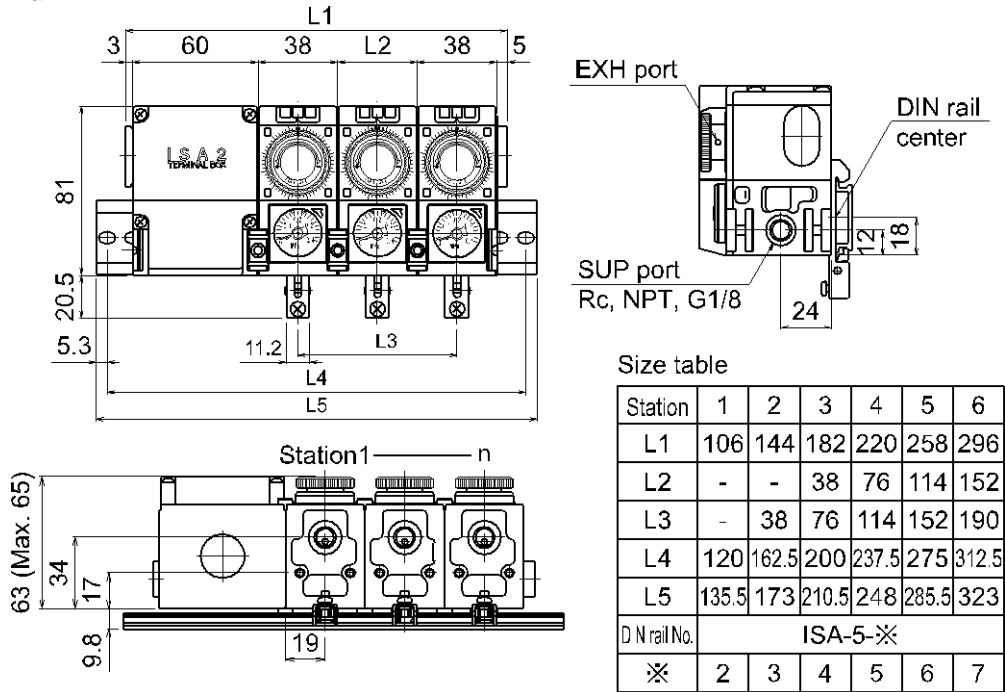

- With control unit
- SUP port: Left side

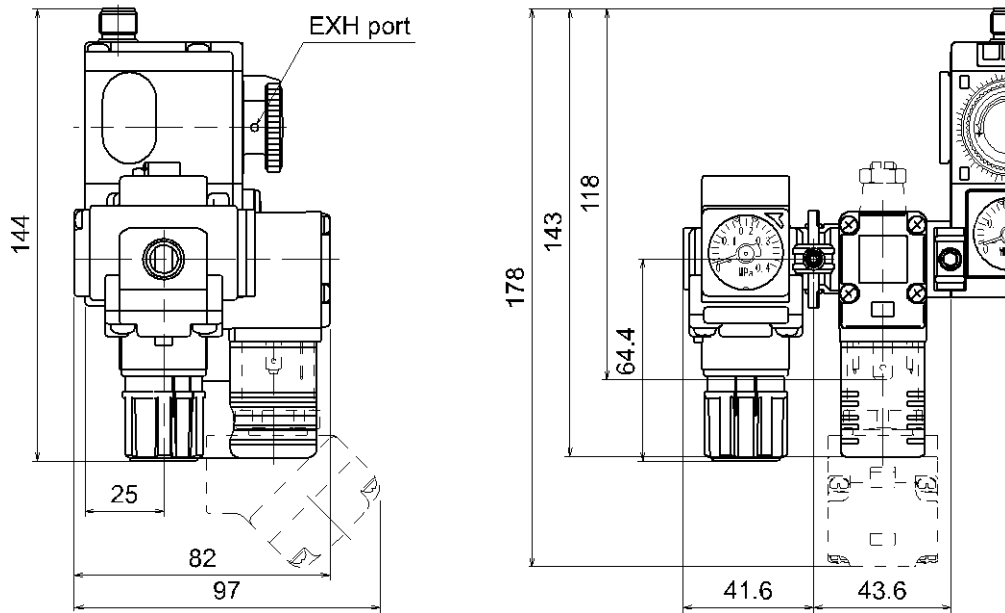

- SUP port: Right side

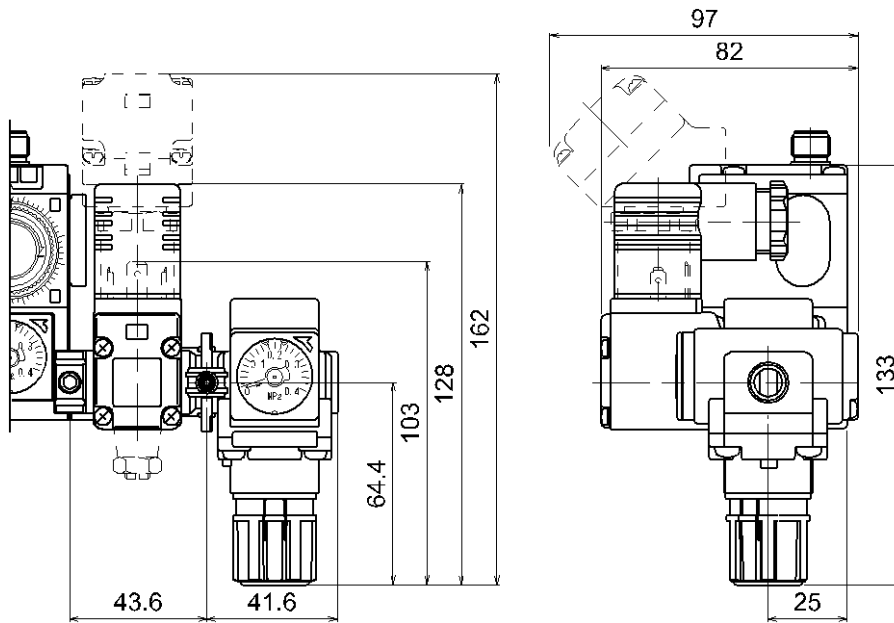

#### Revision history

A: Add the Model.  
B: Add the contents of Trouble shooting.  
C: Revision.  
D: Limited warranty and Disclaimer and measurement laws are added.  
E: Contents revised in several places.  
F: Contents revised in several places. [May 2024]

## SMC Corporation

Tel: + 81 3 5207 8249 Fax: +81 3 5298 5362  
URL <https://www.smcworld.com>

Note: Specifications are subject to change without prior notice and any obligation on the part of the manufacturer.  
© SMC Corporation All Rights Reserved

