



Operation Manual

PRODUCT NAME

PRECISION REGULATOR

MODEL/ Series

I R 3 0 0 0

I R 3 0 1 0

I R 3 0 2 0

SMC Corporation

Contents

Safety Instructions	2 to 3
1. Specifications	4 to 5
2. Construction and operation principle	6
3. How to order	7
4. Marking on product	7
5. Precautions for handling	8 to 11
6. Warranty	12
7. Troubleshooting	13
8. Dimensions	14



Safety Instructions

These safety instructions are intended to prevent hazardous situations and/or equipment damage. These instructions indicate the level of potential hazard with the labels of “**Caution**,” “**Warning**” or “**Danger**.” They are all important notes for safety and must be followed in addition to International Standards (ISO/IEC)^{*)}, and other safety regulations.

*) ISO 4414: Pneumatic fluid power - General rules and safety requirements for systems and their components
ISO 4413: Hydraulic fluid power - General rules and safety requirements for systems and their components
IEC 60204-1: Safety of machinery - Electrical equipment of machines - Part 1: General requirements
ISO 10218-1: Robots and robotic devices - Safety requirements for industrial robots - Part 1: Robots
etc.



Danger

Danger indicates a hazard with a high level of risk which, if not avoided, will result in death or serious injury.



Warning

Warning indicates a hazard with a medium level of risk which, if not avoided, could result in death or serious injury.



Caution

Caution indicates a hazard with a low level of risk which, if not avoided, could result in minor or moderate injury.

Warning

1. The compatibility of the product is the responsibility of the person who designs the equipment or decides its specifications.

Since the product specified here is used under various operating conditions, its compatibility with specific equipment must be decided by the person who designs the equipment or decides its specifications based on necessary analysis and test results. The expected performance and safety assurance of the equipment will be the responsibility of the person who has determined its compatibility with the product. This person should also continuously review all specifications of the product referring to its latest catalog information, with a view to giving due consideration to any possibility of equipment failure when configuring the equipment.

2. Only personnel with appropriate training should operate machinery and equipment.

The product specified here may become unsafe if handled incorrectly. The assembly, operation and maintenance of machines or equipment including our products must be performed by an operator who is appropriately trained and experienced.

3. Do not service or attempt to remove product and machinery/equipment until safety is confirmed.

1. The inspection and maintenance of machinery/equipment should only be performed after measures to prevent falling or runaway of the driven objects have been confirmed.
2. When the product is to be removed, confirm that the safety measures as mentioned above are implemented and the power from any appropriate source is cut, and read and understand the specific product precautions of all relevant products carefully.
3. Before machinery/equipment is restarted, take measures to prevent unexpected operation and malfunction.

4. Our products cannot be used beyond their specifications. Our products are not developed, designed, and manufactured to be used under the following conditions or environments.

Use under such conditions or environments is not covered.

1. Conditions and environments outside of the given specifications, or use outdoors or in a place exposed to direct sunlight.
2. Use for nuclear power, railways, aviation, space equipment, ships, vehicles, military application, equipment affecting human life, body, and property, fuel equipment, entertainment equipment, emergency shut-off circuits, press clutches, brake circuits, safety equipment, etc., and use for applications that do not conform to standard specifications such as catalogs and operation manuals.
3. Use for interlock circuits, except for use with double interlock such as installing a mechanical protection function in case of failure. Please periodically inspect the product to confirm that the product is operating properly.



Safety Instructions

Caution

We develop, design, and manufacture our products to be used for automatic control equipment, and provide them for peaceful use in manufacturing industries.

Use in non-manufacturing industries is not covered.

Products we manufacture and sell cannot be used for the purpose of transactions or certification specified in the Measurement Act.

The new Measurement Act prohibits use of any unit other than SI units in Japan.

Limited warranty and Disclaimer/Compliance Requirements

The product used is subject to the following "Limited warranty and Disclaimer" and "Compliance Requirements". Read and accept them before using the product.

Limited warranty and Disclaimer

1. The warranty period of the product is 1 year in service or 1.5 years after the product is delivered, whichever is first.*2)

Also, the product may have specified durability, running distance or replacement parts. Please consult your nearest sales branch.

2. For any failure or damage reported within the warranty period which is clearly our responsibility, a replacement product or necessary parts will be provided.

This limited warranty applies only to our product independently, and not to any other damage incurred due to the failure of the product.

3. Prior to using SMC products, please read and understand the warranty terms and disclaimers noted in the specified catalog for the particular products.

***2) Vacuum pads are excluded from this 1 year warranty.**

A vacuum pad is a consumable part, so it is warranted for a year after it is delivered.

Also, even within the warranty period, the wear of a product due to the use of the vacuum pad or failure due to the deterioration of rubber material are not covered by the limited warranty

Compliance Requirements

1. The use of SMC products with production equipment for the manufacture of weapons of mass destruction (WMD) or any other weapon is strictly prohibited.

2. The exports of SMC products or technology from one country to another are governed by the relevant security laws and regulations of the countries involved in the transaction. Prior to the shipment of a SMC product to another country, assure that all local rules governing that export are known and followed.

Foreword

The IR3000 precision regulator (hereinafter referred to as the “product”) has excellent relief characteristics, and is constructed to always keep a constant pressure even if used with a reverse flow. The product has the following features.

- (1) A sensitivity of 0.2%F.S. at max is achieved by the nozzle and flapper design.
(IR3000: F.S. \approx 0.2MPa, IR3010: F.S. \approx 0.4MPa, IR3020: F.S. \approx 0.8MPa)
Note) “F.S.” is the abbreviation of full span.
- (2) Various characteristics such as flow rate, pressure characteristics and repeatability are improved compared to general regulators.
- (3) Relief characteristics are improved.
- (4) The adjustment range is as wide as general regulators, which is 0.01~0.8MPa.

1. Specifications

The following specifications are for a single unit of precision regulator. They do not meet the specifications of the actual system.

Model	IR3000	IR3010	IR3020
Fluid	Compressed air (dry air)		
Max. supply pressure	MAX. 1.0MPa		
Min. supply pressure ^(Note 1)	Setting pressure + 0.1MPa		
Setting pressure ^(Note 2)	0.01~0.2MPa	0.01~0.4MPa	0.01~0.8MPa
Setting sensitivity ^(Note 3)	Within 0.2% F.S. ^(Note 4)		
Repeatability ^(Note 5)	Within \pm 0.5% F.S. ^(Note 4)		
Air consumption ^(Note 6)	11.5L/min(ANR) or less (at supply pressure of 1.0MPa)		
Ambient and fluid temperature	-5 to 60°C (No freezing)		
Port size	1/4,3/8,1/2		
Port size of pressure gauge	1/8 [2 places]		
Weight	0.64kg		

- (Note1) Minimum supply pressure: At a downstream side flow rate of zero. Be sure to keep the minimum supply pressure (setting pressure+0.1MPa)
- (Note2) Setting pressure: At a downstream side flow rate of zero.
- (Note3) Setting sensitivity: This is the minimum pressure range that the downstream pressure is adjustable by conducting fine adjustment of the setting knob on the downstream side of the precision regulator.
- (Note 4) The F.S. means the condition at the maximum setting pressure of the product. (F.S. \pm 0.2MPa, IR3000)
- (Note 5) Repeatability: This is the reproducibility of the downstream pressure at every operation (ON/OFF) on the downstream side. The repeatability does not consider the influence of pressure variation due to aging deterioration, temperature change or oscillation of the regulator. The aging deterioration means that the downstream pressure varies gradually affected by change or distortion due to aging of the internal components of the precision regulator.
- (Note 6) Air consumption: This is the combined flow to atmosphere of the bleed and exhaust ports; when the supply pressure is 1.0 MPa and the downstream setting pressure is 0.8 MPa (maximum setting pressure). It does not include any flow for the relief of downstream pressure increases due to back pressure or downstream pressure decreases due to the adjustment of the setting knob.

2. Construction and operation principle

When the ① setting knob is turned, the ③ nozzle is closed by the ② flapper, allowing the supply air that flows in from the upstream side to pass through the ④ fixed orifice. It then acts on upper side of ⑥ diaphragm(C) as nozzle back pressure, the ⑦ main valve is pushed down by the generated force and the supply pressure flows out to the downstream side. The air pressure that flows in acts on bottom side of ⑥ diaphragm(C) and while opposing the force generated by nozzle back pressure, it also acts on ⑤ diaphragm(A) opposing the compression force of the ⑧ setting spring and becomes the set pressure. When the output pressure raises above the setting pressure, ⑤ diaphragm(A) is pushed up which makes the interval between the ② flapper and the ③ nozzle widens, the nozzle back pressure drops, the pressure balance of upper/bottom part of ⑥ diaphragms(C) is broken. Then as the ⑦ main valve closes, the ⑨ exhaust valve opens at the same time and the excess pressure from the downstream side is discharged to the atmosphere. In this way fine pressure variations are detected by the nozzle/flapper type pilot mechanism, and precise pressure adjustment is performed.

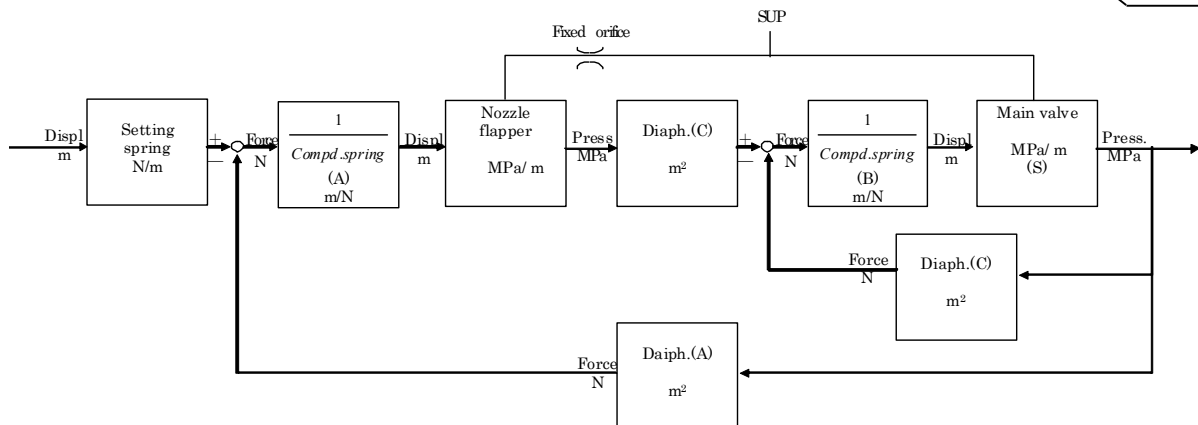
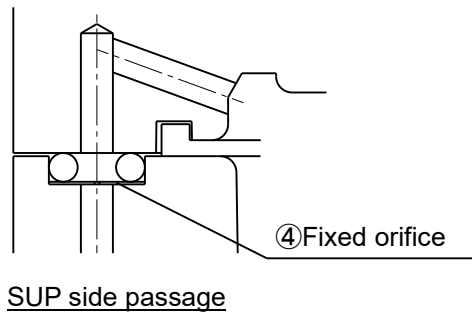
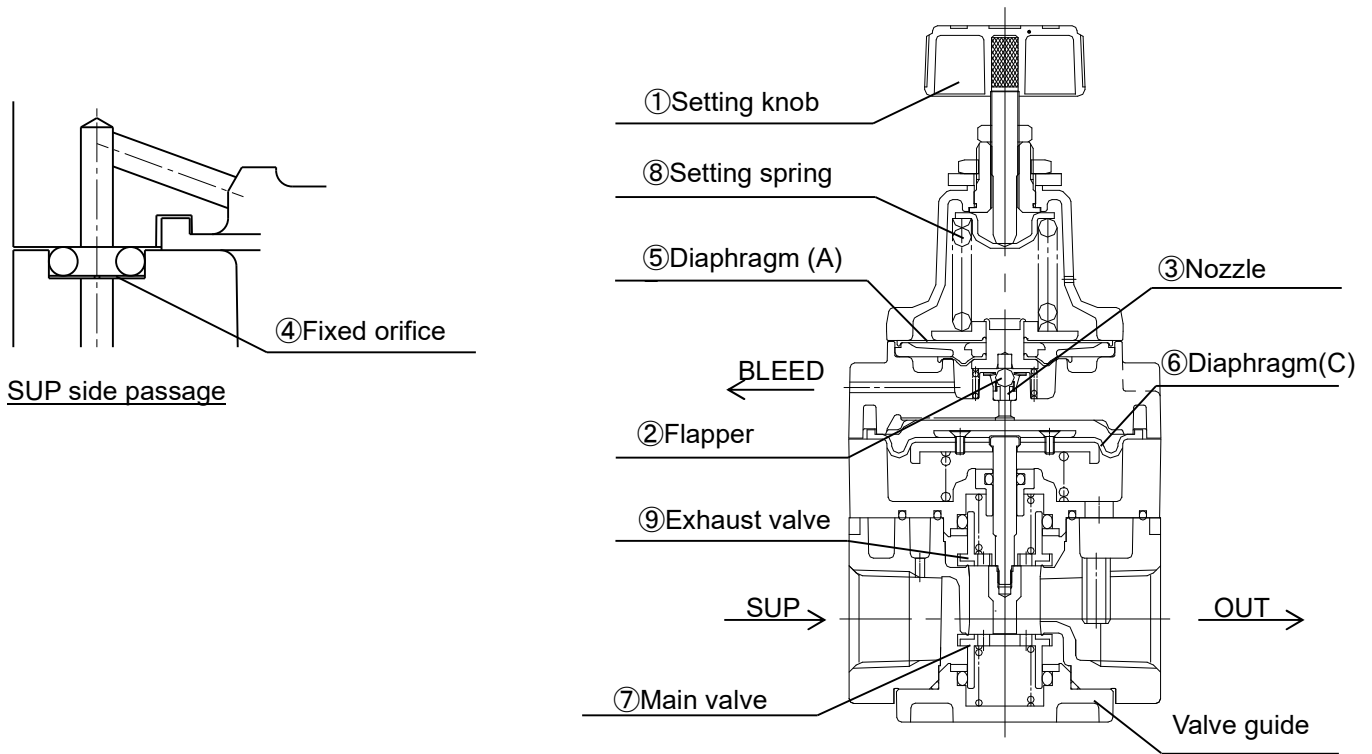

Block diagram

3. How to order

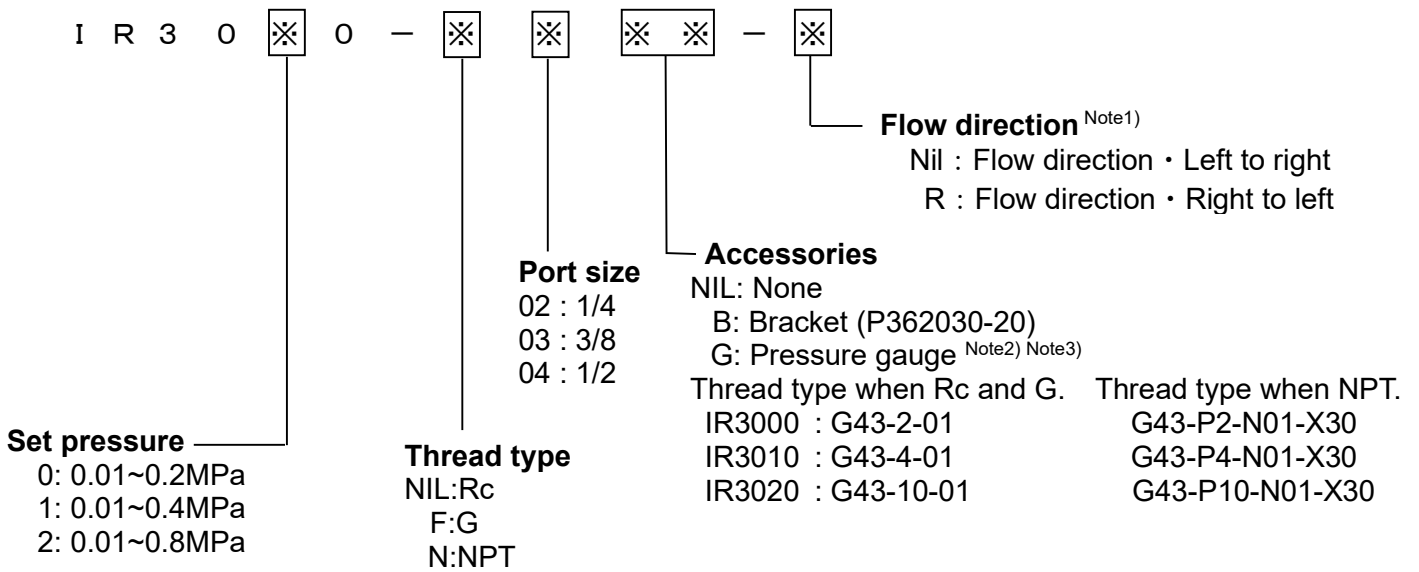

(Note 1) The flow direction of the suffix is the direction when viewing with the name plate of the precision regulator in front.

(Note 2) Accuracy: ±3%F.S.(full span)
 Accuracy guarantee temperature range : 23±5°C

(Note 3) The pressure gauge is not attached and becomes bundled shipment.

4. Marking on product

· Product name plate

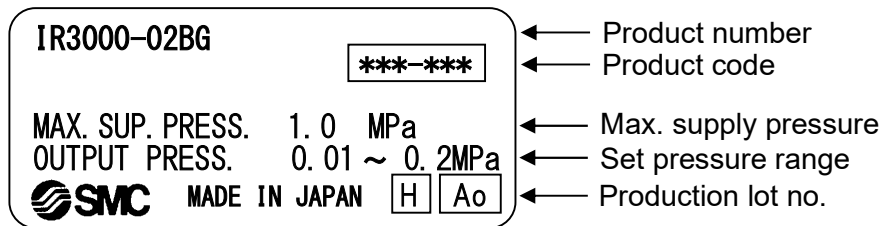

Production lot no.

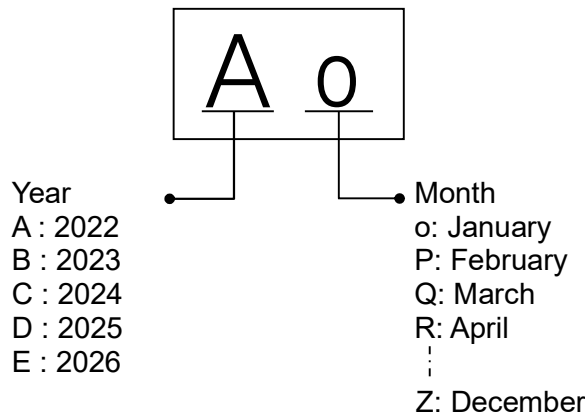

5. Precautions for handling

Fluid

Warning

- (1) Do not use compressed air which contains chemicals, synthetic oils containing organic solvents, salts or corrosive gases, etc., as this can cause damage or malfunction.
- (2) If the drain removal from air filter and mist separator is missed, drain will be flown out to the outlet side and may result in a malfunction of the pneumatic equipment. When removing drain is difficult, use of a filter with an auto drain is recommended.

Caution

- (1) Condensate and dust in on the supply (upstream) side piping can clog the fixed orifice, which may lead to operation failure. Make sure to install a mist separator (SMC AFM series / Filtration of 0.3 μm) as well as an air filter (SMC AF series), and exhaust the condensate or replace the element regularly. To maintain good air condition, refer to "Air Preparation Equipment Model Selection Guide" select the C or higher (D, E, F, G or H) level.
- (2) Never use a lubricator on the supply side of the precision regulator, as this will positively cause the fixed throttle to become clogged and result in a malfunction*. If lubrication is required for terminal devices, connect a lubricator on the output side of the precision regulator.

* The following may occur if the fixed throttle is clogged or is getting clogged.

- No output
- Set pressure drops.
- Set pressure is unstable
- Outlet pressure slowly rises.

Operating environment

Warning

- (1) Do not use in an atmosphere having corrosive gases, chemicals, sea water, water, water steam, or where there is direct contact with any of these.
- (2) Do not operate in locations where vibration or impact occurs.
- (3) In locations which receive direct sunlight, provide a protective cover, etc.
- (4) In locations near heat sources, block off any radiated heat.
- (5) In locations where there is contact with spatter from water, oil or solder, etc., implement suitable protective measures.

Maintenance

Warning

- (1) When the valve guide (refer to construction drawing on page 6) is to be removed during maintenance, first reduce the set pressure to "0" and completely shut off the supply pressure.
- (2) When a pressure gauge is to be mounted, remove the plug after reducing the set pressure to "0".
- (3) Rubber parts such as diaphragm, o-rings and seals are consumption, and should be replaced every three years. If the fixed orifice is exposed to contamination from extended use of the precision regulator, the product may not operate within specification. It is recommended checked every year, and replacing the part every three years.
- (4) Ensure to exhaust the condensate of the filters installed on the supply (upstream) side, wash the element and pipings, and perform replacement regularly. Although it depends on the operating conditions, the guideline is every month or every three months.
- (5) When removing the equipment for maintenance, contamination may enter the pipe and the precision regulator. Please flush the pipe and fittings thoroughly with air before reconnecting them to remove the foreign matter or contamination from the piping materials.

Piping

Warning

- (1) Connect piping/fittings using the recommended torque while holding the product tightly. Loose or faulty sealing can occur if tightening torque is insufficient, while damage to the thread can occur if over tightened. If the product is not held while tightening, excessive force will be applied to the product bracket, causing breakage.

Recommended tightening torque (N · m)

Thread size	1/4	3/8	1/2
Torque	12 to 14	22 to 24	28 to 30

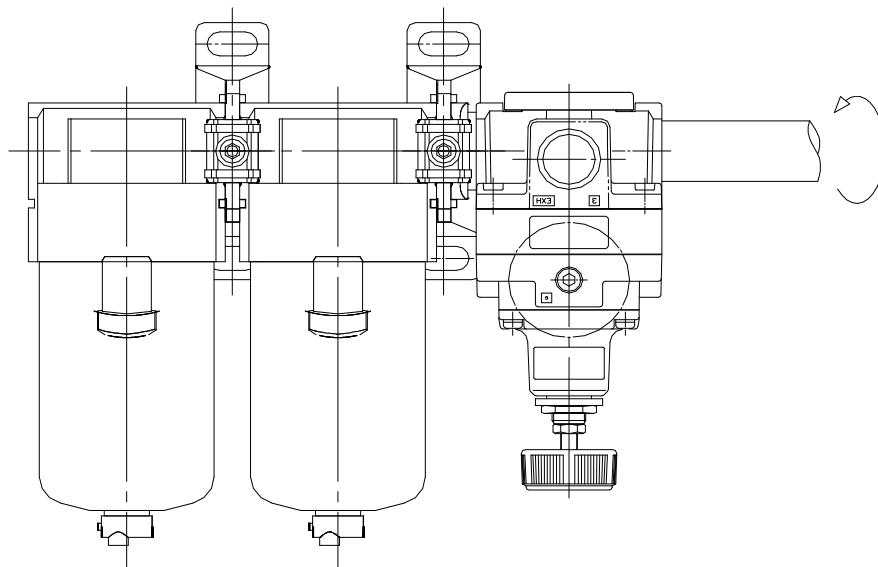

- (2) Do not apply torsion or bending moment other than the weight of the product itself. The external piping should be supported separately because it may cause breakage.

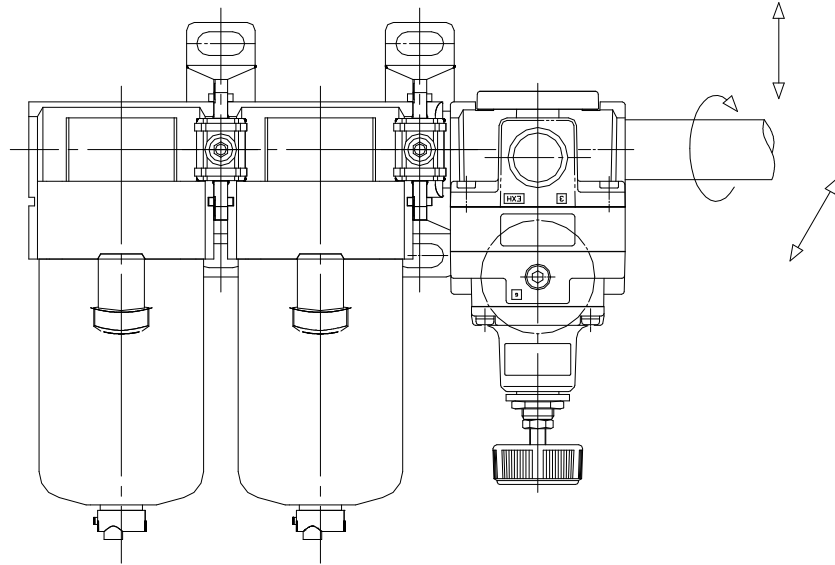

- (3) Non-flexible piping such as steel piping will be subject to excessive moment load and vibration from the piping side, so use a flexible tube for intermediate connection.
- (4) If the failure of the product will cause danger in the system, install a safety circuit and configure the system so that danger can be avoided
- (5) Be sure to confirm the port indication when connecting the product.
- (6) Before piping, perform air blow (flushing) or cleaning to remove any cutting chips, cutting oil, dust, etc. from the piping.
- (7) When installing piping or fitting into a port, prevent cutting chips and sealant material from getting inside the piping. If a sealant tape is used, leave 1.5 to 2 threads exposed.

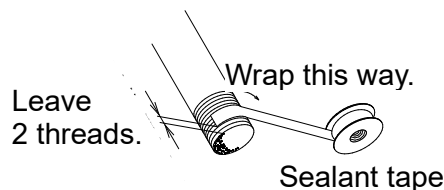

Handling

Caution

- (1) When the precision regulator with pressure gauge is used, do not apply impact to the product by dropping it, etc. during transportation or installation. This may cause misalignment of the pressure gauge pointer.

Warning

- (1) Do not use a precision regulator outside the range of its specifications as this can cause failure.(Refer to the specifications.)
- (2) When mounting is performed, make connections while confirming port indications.
- (3) Screw a panel nut with the recommended proper torque 21N·m when mounting onto a panel. Looseness or faulty sealing will occur if tightening torque is insufficient, while thread damage will result if the torque is excessive.
- (4) If a directional switching valve (solenoid valve, mechanical valve, etc.) is mounted on the supply side of the regulator and repeatedly switched ON and OFF, wear of the nozzle/flapper section will be accelerated and a discrepancy in the setting value may occur. Therefore, avoid using a directional switching valve on the supply side. In the event a directional switching valve will be used, install it on the output side of the precision regulator.
- (5) The accessory pressure gauge is supplied with the precision regulator in the unassembled status. Before using the precision regulator, be sure to install the pressure gauge at the gauge port of the precision regulator. At this time, the recommended tightening torque of the pressure gauge is 7 to 9N·m.
- (6) Air is normally released from the bleed hole (the hole on the side of the body's mid-section). This is a necessary consumption of air based on the construction of the precision regulator, and is not an abnormality.
- (7) Make sure to tighten the lock nut after pressure adjustment.
- (8) There may be pulsation or noise depending on the pressure conditions, piping conditions and ambient environment. In this case, it is possible to improve the problem by changing the pressure conditions and piping conditions. If the problem is not improved, please contact your SMC sales representative.
- (9) After the pressure is supplied from the upstream side or the set pressure has been adjusted, the set pressure may gradually vary depending on the secular change of internal parts. If the variation in the set pressure has become large, readjust the set pressure using the setting knob.
- (10) The set pressure may vary if it is influenced by the variation in ambient temperature or fluid temperature. If the set pressure varies due to the influence of temperature, consider the management of ambient and fluid temperatures.
- (11) The supply pressure is relatively high (approx.0.5 MPa or more), the set pressure is low (approx.0.1 MPa or less), and when operated with the output side released to the atmosphere, there may be pulsations in the setting pressure. In this kind of situation, operate with the supply pressure reduced as much as possible, or increase the set pressure somewhat and restrict the output line (add and adjust a stop valve, etc.).
- (12) The capacity of the output side is large, and when used for the purpose of a relief function, the exhaust sound will be loud when being relieved. Therefore, operate with a silencer (SMC AN series) mounted on the exhaust port (EXH port). The connection is 1/2.

6. Warranty

- (1) Period: The warranty period of the product is 1 year in service or 1.5 years after the product is delivered, whichever is first.
- (2) Scope: For any failure or damage reported within the warranty period which is clearly our responsibility, a replacement product or necessary parts will be provided. This limited warranty applies only to SMC product independently, and not to any other damage incurred due to the failure of the product.
- (3) Content:
 - a. We guarantee that the product will operate normally if it is installed under maintenance and control in accordance with the Operation Manual, and operated under the conditions specified in the catalog or contracted separately.
 - b. We guarantee that the product does not have any defects in components, materials or assembly.
 - c. We guarantee that the product complies with the outline dimensions provided.
 - d. The following situations are out of scope of this warranty.
 - (1) The product was incorrectly installed or connected with other equipment.
 - (2) The product was under insufficient maintenance and control or incorrectly handled.
 - (3) The product was operated outside of the specifications.
 - (4) The product was modified or altered in construction.
 - (5) The failure was a secondary failure of the product caused by the failure of equipment connected to the product.
 - (6) The failure was caused by a natural disaster such as an earthquake, typhoon, or flood, or by an accident or fire.
- (4) Agreement: If there is any doubt about anything specified in "Scope" and "Content", it shall be resolved by agreement between the customer and SMC.

7. Troubleshooting

No.	Trouble	Possible cause	Countermeasures	
1	The set pressure is decreasing.	Fluctuation of flow rate at the downstream side	Reset the pressure. Return the flow rate at the downstream side to the initial rate.	
		Clogging of fixed orifice due to moisture, condensation or foreign matter	Install a filter and mist separator and use clean air.	
		Leakage due to deterioration of rubber parts	Ozone	Replace with an ozone resistant product (80- series).
			Copper	Change the material of piping, etc. from copper.
			Temperature	Avoid using at high temperature or low temperature.
			Petroleum type oil	Prevent the oil from entering the ambient environment and fluid.
		Frequent switch of on and off at the downstream side	Reset the pressure again.	
The decrease of pressure in the bonnet	Set the pressure in the bonnet, which is a standard pressure, to atmospheric pressure.			
2	The set pressure is increased or decreased over time.	Change of the product over time	Reset the pressure again.	
3	Response is slow.	Clogging of fixed orifice due to moisture, condensation or foreign matter	Install a filter and mist separator and use a clean air.	
		Increased consumed flow rate at the downstream side (due to leakage, etc.)	Eliminate leakage in the piping.	
4	The leakage at the EXH port has increased.	Leakage due to deterioration of rubber parts	Ozone	Replace with an ozone resistant product (80- series).
			Copper	Change the material of piping, etc. from copper.
			Temperature	Avoid using at high temperature or low temperature.
			Petroleum type oil	Prevent the oil from entering the ambient environment and fluid.
		Foreign matter stuck to the seating part	Install a filter and mist separator and use clean air. Perform flushing by releasing the downstream side to atmosphere, etc.	
5	The set pressure changes periodically.	Fluctuation of supply pressure	Install the regulator in front to reduce the fluctuation.	
		Change of ambient and fluid temperature	Prevent the effect of temperature change.	
6	Pressure does not increase.	Insufficient supply pressure	Increase the supply pressure.	
		Clogging of fixed orifice due to moisture, condensation or foreign matter	Install a filter and mist separator and use clean air.	
7	Repeatability is poor.	Same as trouble 1.	Refer to problem 1.	
		Same as trouble 2.	Refer to problem 2.	
8	The product is chattering.	Leakage at the downstream side	Eliminate leakage in the piping.	
		Problem with the piping at the downstream side	Chattering occurs depending on the operating conditions. Consult SMC.	
9	There is leakage at the places other than the bleed hole and EXH port.	Leakage due to deterioration of rubber parts	Consult SMC.	

8 . Dimensions

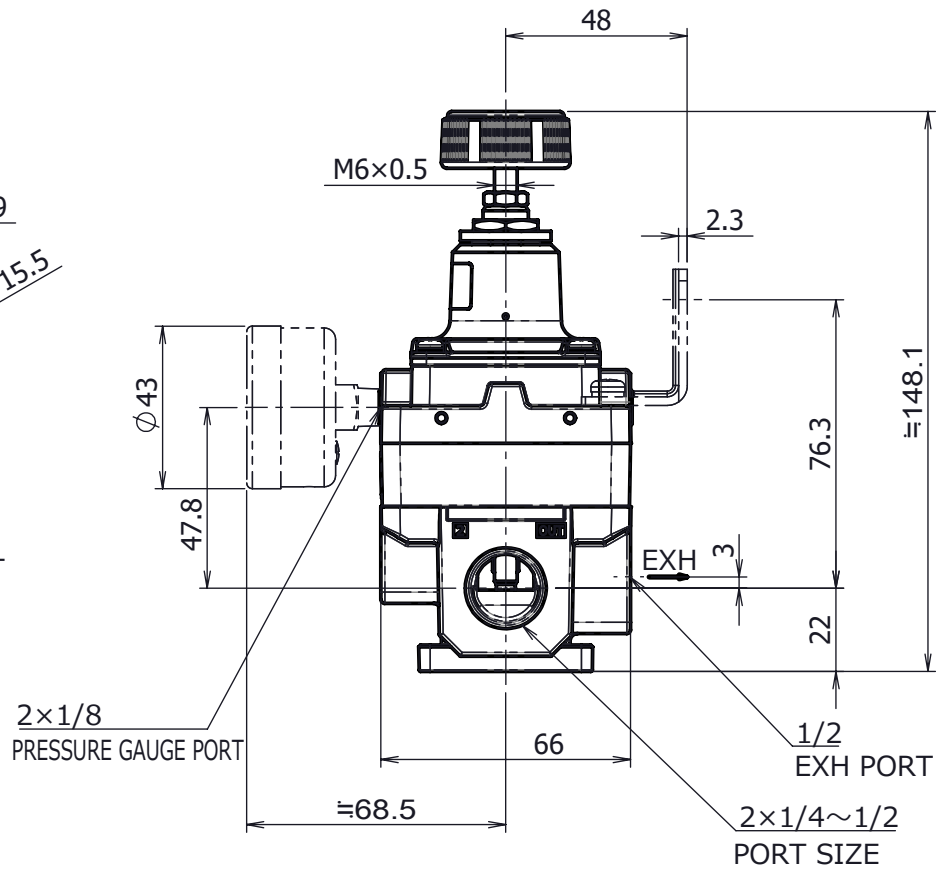
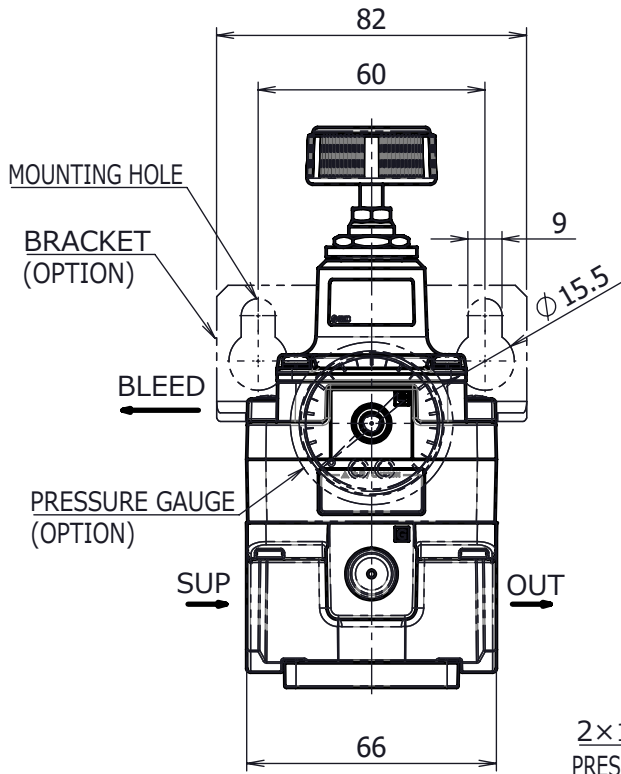

Revision history

- A Thread type (NPT,G) addition
- B Format change and content review
- C Sectional view filter deletion of P.5
- D Name plate layout change
- E Content review
- F P.5 Sectional view change
- G Safety Instructions revised

SMC Corporation

Tel: + 81 3 5207 8249 Fax: +81 3 5298 5362
URL <https://www.smcworld.com>

Note: Specifications are subject to change without prior notice and any obligation on the part of the manufacturer.
© SMC Corporation All Rights Reserved