



Operation Manual

SMART POSITIONER (ROTARY TYPE)
For HART Communication

PRODUCT NAME

IP8101-0*3
52-IP8101-0*4

MODEL/ Series

SMC Corporation

Safety Instructions	4
Introduction	6
Specification	6
Function of HART Communication	6
Menu Tree	7
Parameter Comparison	8
Confirmation and Change of Device Information	9
Confirmation and Change of Device Information	9
1. Confirmation and Change of Positioner Information	9
2. Confirmation and Change of HART Communication Setting	9
3. Confirmation and Change of Maintenance Setting	10
Confirmation and Change of Positioner Operating Conditions	10
Manual Mode Setting	11
Calibration	11
Actuator Type Setting	12
Parameter Setting	12
HART Communication	13
IP8101 Smart Positioner	13
375/475 Field Communicator	13
Workflow of IP8101 Positioner Setup	14
Operating Principle	15
Mounting	15
Piping	15
Electrical Wiring	16
Electrical Wiring for Positioner	16
375/475 Field Communicator Wiring	16
Before Starting HART Communication	16
Positioner's LCD Display During HART Communication	16
Switching HART Communication function	17
HART Communication Method	17
Procedure to Start HART Communication	17
Initial Adjustment	18
Change of Parameters for Initial Operation	18
Initial Adjustment	18
1. Selection of parameter mode	18

2.Adjustment of fork lever-type fitting angle	19
3.Simple balance current adjustment	20
4.Calibration	21
5.Input current calibration	22
Operation	23
Operation Mode	23
Operation and Operation Mode Shift	24
Operation Shift	24
Auto Mode Operation	25
Auto Mode	25
Operation Confirmation During Auto Mode	25
Manual Mode Operation	25
Manual Mode	25
Operation During Manual Mode	25
Setting Parameters	26
Parameter Code Detail	26
Actuator Type	26
Detail Set Up	26
Calibration	30
Parameter Setting Default Value List	34
Improved Controllability	34
Hot Key	34
Scale Plate Adjustment	34
Maintenance and Check	34
Instructions	34
Compressed Air Cleaning Equipment	34
Status Error	35
Troubleshooting and Error Status	36
Troubleshooting	36
Error Status List	37
How to Order	39
Drawing	39



Safety Instructions

These safety instructions are intended to prevent hazardous situations and/or equipment damage. These instructions indicate the level of potential hazard with the labels of “**Caution**,” “**Warning**” or “**Danger**.” They are all important notes for safety and must be followed in addition to International Standards (ISO/IEC)^{*)}, and other safety regulations.

*) ISO 4414: Pneumatic fluid power - General rules and safety requirements for systems and their components
 ISO 4413: Hydraulic fluid power - General rules and safety requirements for systems and their components
 IEC 60204-1: Safety of machinery - Electrical equipment of machines - Part 1: General requirements
 ISO 10218-1: Robots and robotic devices - Safety requirements for industrial robots - Part 1: Robots
 etc.



Danger

Danger indicates a hazard with a high level of risk which, if not avoided, will result in death or serious injury.



Warning

Warning indicates a hazard with a medium level of risk which, if not avoided, could result in death or serious injury.



Caution

Caution indicates a hazard with a low level of risk which, if not avoided, could result in minor or moderate injury.



Warning

1. The compatibility of the product is the responsibility of the person who designs the equipment or decides its specifications.

Since the product specified here is used under various operating conditions, its compatibility with specific equipment must be decided by the person who designs the equipment or decides its specifications based on necessary analysis and test results. The expected performance and safety assurance of the equipment will be the responsibility of the person who has determined its compatibility with the product. This person should also continuously review all specifications of the product referring to its latest catalog information, with a view to giving due consideration to any possibility of equipment failure when configuring the equipment.

2. Only personnel with appropriate training should operate machinery and equipment.

The product specified here may become unsafe if handled incorrectly. The assembly, operation and maintenance of machines or equipment including our products must be performed by an operator who is appropriately trained and experienced.

3. Do not service or attempt to remove product and machinery/equipment until safety is confirmed.

1. The inspection and maintenance of machinery/equipment should only be performed after measures to prevent falling or runaway of the driven objects have been confirmed.
2. When the product is to be removed, confirm that the safety measures as mentioned above are implemented and the power from any appropriate source is cut, and read and understand the specific product precautions of all relevant products carefully.
3. Before machinery/equipment is restarted, take measures to prevent unexpected operation and malfunction.

4. Our products cannot be used beyond their specifications. Our products are not developed, designed, and manufactured to be used under the following conditions or environments. Use under such conditions or environments is not covered.

1. Conditions and environments outside of the given specifications, or use outdoors or in a place exposed to direct sunlight.
2. Use for nuclear power, railways, aviation, space equipment, ships, vehicles, military application, equipment affecting human life, body, and property, fuel equipment, entertainment equipment, emergency shut-off circuits, press clutches, brake circuits, safety equipment, etc., and use for applications that do not conform to standard specifications such as catalogs and operation manuals.
3. Use for interlock circuits, except for use with double interlock such as installing a mechanical protection function in case of failure. Please periodically inspect the product to confirm that the product is operating properly.



Safety Instructions

Caution

We develop, design, and manufacture our products to be used for automatic control equipment, and provide them for peaceful use in manufacturing industries.

Use in non-manufacturing industries is not covered.

Products we manufacture and sell cannot be used for the purpose of transactions or certification specified in the Measurement Act.

The new Measurement Act prohibits use of any unit other than SI units in Japan.

Limited warranty and Disclaimer/Compliance Requirements

The product used is subject to the following “Limited warranty and Disclaimer” and “Compliance Requirements”.

Read and accept them before using the product.

Limited warranty and Disclaimer

1. The warranty period of the product is 1 year in service or 1.5 years after the product is delivered, whichever is first.*2)

Also, the product may have specified durability, running distance or replacement parts. Please consult your nearest sales branch.

2. For any failure or damage reported within the warranty period which is clearly our responsibility, a replacement product or necessary parts will be provided.

This limited warranty applies only to our product independently, and not to any other damage incurred due to the failure of the product.

3. Prior to using SMC products, please read and understand the warranty terms and disclaimers noted in the specified catalog for the particular products.

***2) Vacuum pads are excluded from this 1 year warranty.**

A vacuum pad is a consumable part, so it is warranted for a year after it is delivered.

Also, even within the warranty period, the wear of a product due to the use of the vacuum pad or failure due to the deterioration of rubber material are not covered by the limited warranty

Compliance Requirements

1. The use of SMC products with production equipment for the manufacture of weapons of mass destruction (WMD) or any other weapon is strictly prohibited.

2. The exports of SMC products or technology from one country to another are governed by the relevant security laws and regulations of the countries involved in the transaction. Prior to the shipment of a SMC product to another country, assure that all local rules governing that export are known and followed.

Introduction

IP8101 Smart Positioner provides HART protocol communication as an option. Calibration, operation setting, and data confirmation become available by using 375/475 field communicator. Refer 375/475 field communicator manual of EMERSON for the operation. This operation manual specifies HART communication functions only. Operation manual of “SMART POSITIONER (No.:DIG-31900-OM002)” shall be referred for basic operation of IP8101 smart positioner.

Specifications

Other than HART communication, specifications are the same as basic type. Refer “■ Specification” of operation manual of “SMART POSITIONER (No.:DIG-31900-OM002)” for specifications.

Function of HART Communication

Table 1 shows main functions of HART communication.

Table 1

Content	Details
Confirmation and change of device	Confirmation and change of positioner information
	Setting and confirmation of maintenance time
	Confirmation and change of HART communication setting
Confirmation of operation	Confirmation of actuator open degree
	Confirmation of input current
	Confirmation of analog output, alarm output
	Confirmation of alarm status
Calibration	Auto zero span adjustment
	Confirmation of fork lever angle
	Confirmation of balance current
	Correction of input current, analog output
Operation setting and change	Operation direction setting
	Split range setting
	Manual span setting
	Forced fully open/fully close setting
	Valve open degree character setting
	PID constant setting

Menu Tree

B

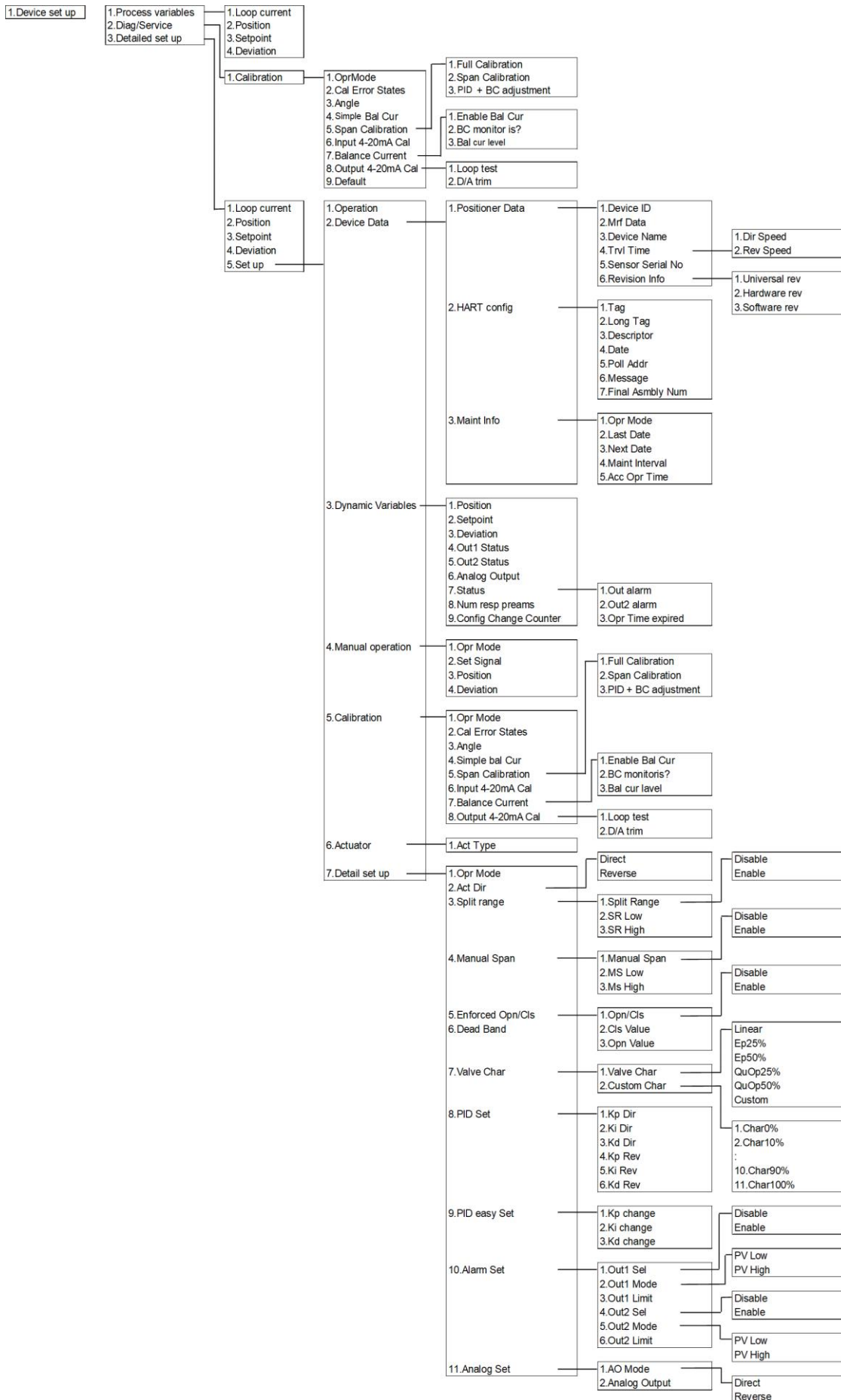

Parameter Comparison

B

In HART communication parameter setting items, there are items which function is the same as button operation of the main unit, but different description. Table 2 shows the comparison of expression of Operation manual “SMART POSITIONER (No.:DIG-31900-OM002)” and the expression of 375/475 field communicator. Refer “■ Menu Tree”.

Table 2

	Operation Manual "SMART POSITIONER" (No.:DIG-31900-OM002)	Expression by "375/475 Field Communicator"	Menu Tree No.
Parameter Setting	Actuator type	Actype	1-3-5-6-1
	Operation direction	Act Dir	1-3-5-7-2
	Split range	Split Range	1-3-5-7-3
	Zero point / span	Manual Span	1-3-5-7-4
	Forced fully close/ fully open	Enforced Opn/Cls	1-3-5-7-5
	Dead band	Dead Band	1-3-5-7-6
	Valve opening characteristics	Valve Char	1-3-5-7-7
	PID constant of detail setting	PID Set	1-3-5-7-8
	Easy adjustment of PID constant	PID easy Set	1-3-5-7-9
	Alarm 1	Alarm Set→Out1 ***	1-3-5-7-10
	Alarm 2	Alarm Set→Out2 ***	1-3-5-7-10
	Analog output	Analog Set	1-3-5-7-11
	Calibration	Angle adjustment	Angle
Simple balance current adjustmen		Simple Balance Current	1-2-1-4 or 1-3-5-5-4
Calibration		Span Calibration→Full Calibration	1-2-1-5-1 or 1-3-5-5-5-1
Input current calibration		Input 4-20mA	1-2-1-6
Balance current confirmation		Balance Current Cal	1-2-1-7
Span adjustment		Span Calibration→Span Calibration	1-2-1-5-2
-		Span Calibration→PID + Bal cur	1-3-5-5-3

Confirmation and Change of Device Information

B

■ Confirmation and Change of Device Information

<1. Confirmation and Change of Positioner Information [Menu Tree No.: 1-3-5-2-1] >

Devicd set up → Detailed set up → Set up → Device Data → Positioner Data Select items below and confirm and change.

	Item	Content	
1	Device ID	Positioner board ID info. can be confirmed.	
2	Mfr Date	Manufacturing date of board used in IP8101 smart positioner can be confirmed.	
3	Device Name	Device name can be confirmed. "SMC POSITIONER" is displayed.	
4	Trvl Time* ¹	Actuator "Dir Speed", "Rev Speed" which are automatically measured during full calibration and PID adjustment are displayed in "second".	
5	Sensor Serial No.	Potentiometer's serial No. can be confirmed.	
6	Revision Info	Universal rev	Revision of HART protocol which is used for communication with HART protocol is displayed.
		Hardware rev	Revision of positioner board is displayed.
		Software rev	Revision of positioner software is displayed

*1: Direct direction (Dir) means the direction in which operation is started by air output from "OUT1" port of main unit of positioner. Reverse direction (Rev.) means direction in which operation is started by air output from "OUT2" port of main unit of positioner.

<2. Confirmation and Change of HART Communication Setting [Menu Tree No.: 1-3-5-2-2] >

Devicd set up → Detailed set up → Set up → Device Data → HART Config Select items below to confirm and change. Setting change is available in auto, manual, parameter mode.

	Item	Content
1	Tag	Confirm and change the tag assigned to positioner. Tag is used to identify connected positioner. Characters can be input up to eight.
2	Long Tag	Confirm and change long tag assigned to positioner. Long tag is used to identify connected positioner. Characters can be input up to thirty three.
3	Descriptor	User can input information. No specified usage. Characters can be input up to sixteen.
4	Date	User can specify date. No specified usage.
5	Poll Addr	Positioner's address. Set "0" when communicate with positioner directly. Set 0 to 15 when multiple device are used in the same loop like split range or multi-drop. Depends on setting, 375/475 field communicator settings need to be changed.
6	Message	User can input message. No specified usage. Characters can be input up to thirty two.
7	Final Asmbly Num	Confirm and change special control number like the final setting date.

<3. Confirmation and Change of Maintenance Setting [Menu Tree No.: 1-3-5-2-3] >

Devicd set up → Detailed set up → Set up → Device Data → Maint Info Select items below to confirm and change. Items can be changed only during parameter mode. During auto mode and manual mode, change the operation mode to parameter mode.

	Item	Content
1	Opr Mode	Operation mode can be changed
2	Last Date	Input the last maintenance date. "Acc Opr Time" is reset by inputting final maintenance date.
3	Next Date	User input the next maintenance date.
4	Maint Interval	Input maintenance time interval in "hours".
5	Acc Opr Time * ²	If "Maint Interval" is input, positioner operation time starts to be accumulated from the time of inputting "Last Date". It is displayed in "hours".

*2: Accumulation is made every hour. If input current is cut before one hour passed from the last count, accumulation less than one hour is reset. If input current is cut after 1 hour and 45min., accumulation time is regarded as 1 hour, and the next accumulation starts from 1hour when input current is applied.

■ Confirmation and Change of Positioner Operating Conditions [Menu Tree No.: 1-3-5-3]

Devicd set up → Detailed set up → Set up → Dynamic Variables Select items below to confirm and change.

	Items	Content
1	Position	Displays current position value in "%".
2	Setpoint	Display current input value in "%".
3	Deviation	Display position deviation to current input value in "%".
4	Out1 Status	OUT1 alarm output condition can be confirmed. "ON" during output, and "OFF" during not output.
5	Out2 Status	OUT2 alarm output condition can be confirmed. "ON" during output, and "OFF" during not output.
6	Analog Output	Analog output value being output can be confirmed. Displayed in "%".
7	Status	OUT1 alarm and OUT2 alarm output condition, and maintenance time overrun can be confirmed.
8	Num resp preams	Positioner's individual preamble figure can be confirmed. Can be changed to value in 5 to 20.
9	Config Change Counter	Displays the time of positioner's parameter setting change. User can not reset this.

■ Manual Mode Setting [Menu Tree No.: 1-3-5-4]

Devicd set up → Detailed set up → Set up → Manual Operation Select items below to confirm and change. If the positioner is operated with manual mode, change the operation mode to manual mode.

	Item	Content
1	Opr Mode	Operation mode can be changed.
2	Set Signal	Input value can be input during manual mode. Other than manual mode, currently input value is displayed in “%”.
3	Position	Display present position value in “%”.
4	Deviation	Display position deviation to current input value in “%”.

■ Calibration [Menu Tree No.: 1-3-5-5]

Devicd set up → Detailed set up → Set up → Calibration Select items below to confirm and change. Items can be executed only during parameter mode.

	Item	Content
1	Opr Mode	Operation mode can be changed
2	Cal Error Status	Display error info. occurred during calibration *3.
3	Angle	Fork lever angle can be confirmed.
4	Simple Bal Cur	Simple adjustment of balance current is available.
5	Span Calibration	Adjust zero/span. Depends on adjustment, full calibration, span calibration, PID + balance adjustment can be executed.
6	Input 4-20mA Cal	Input signal calibration can be executed.
7	Balance Current *4	Present balance current adjustment condition can be confirmed. “0” means correct condition. If figure other than “0” is displayed, turn the adjustment screw so that the display becomes “0”.
8	Output 4-20mA Cal	Analog output calibration can be executed.

*3: Refer “■Error Status List” for error status details. And recalibrate according to “■Error Status List”.

*4: Becomes operable after initial adjustment is completed.

■ Actuator Type Setting [Menu Tree No.: 1-3-5-6-1]

Devicd set up → Detailed set up → Select Set up → Manual Operation. With IP8101, type can not be changed other than rotary.

	Item	Content
1	Actype	Display “Rotary”

■ Parameter Setting [Menu Tree No.: 1-3-5-7]

Devicd set up → Detailed set up → Select Set up → Detail setup to confirm and change items below. Items can be executed only during parameter mode. If operation is in auto mode or manual mode, change the operation mode to parameter mode.

	Item	Content
1	Opr Mode	Operation mode can be changed.
2	Act Dir	Operating direction can be changed.
3	Split Range	Split range can be set.
4	Manual Span	Actuator open degree at 0% and 100% of input current can be set.
5	Enforced Opn/Cls	Input current which fully close or fully open by force can be set. This is set at ON(Fully close = 0.5%, fully open = 99.5%) when shipped out.
6	Dead Band	Deviation to which dead-band is applied can be set.
7	Valve Char	Valve open degree character can be set by linear, equal %, quick open, and custom.
8	PID Set	Positioner controllability can be changed.
9	PID easy Set	Positioner's controllability can be easily set.
10	Alarm Set	Actuator open degree on which alarm goes can be set.
11	Analog Set	Proportional output or reversed output of analog output can be set.

Caution

1. Refer 375/475 field communicator manual from EMERSON for 375/475 field communication usage.
2. Unless input current 4 to 20mADC is supplied to IP8101 smart positioner, HART communication is not available.

■ IP8101 Smart Positioner

This manual describes the version below. Communication may not be available if version is not the same.

HART Universal command revision: 7

■ 375/475 Field Communicator

If operate IP8101 Smart positioner with 375/475 field communicator, perform “Check for Updates” in “375/475 Easy Upgrade Programming Utility” to register IP8101 positioner data to 375/475. (Refer 375/475 field communicator manual from EMERSON for details). When IP8101 Smart positioner is not registered yet, contact SMC. Update 375/475 field communicator firmware and module upon necessity.

Workflow of IP8101 Positioner Setup

B

The workflow of IP8101 smart positioner from setup to initial adjustment is shown below. Follow this flow when performing setups and adjustments of the positioner. Refer operation manual “SMART POSITIONER (No.:DIG-31900-OM002)” for details of installation.

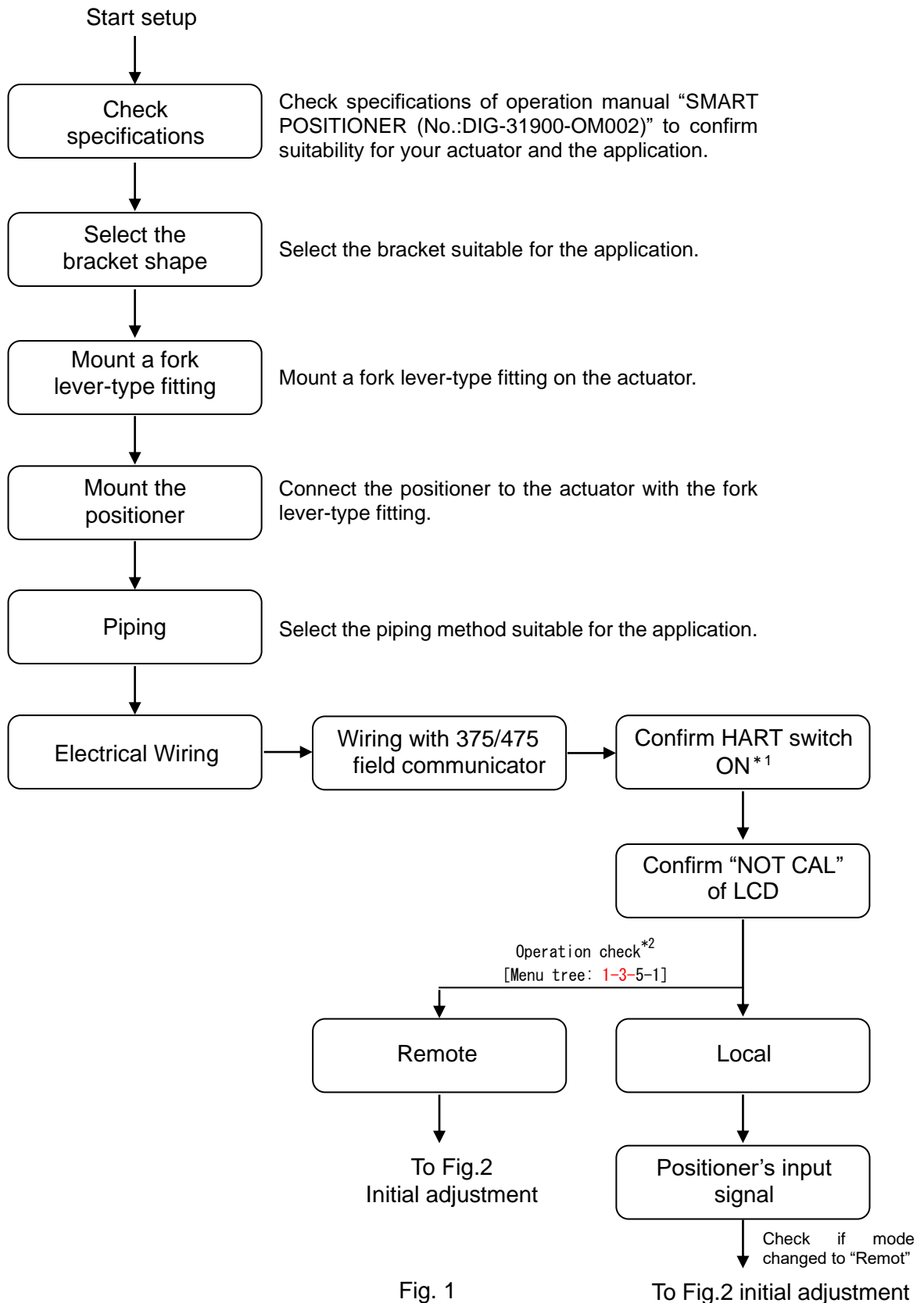

Fig. 1

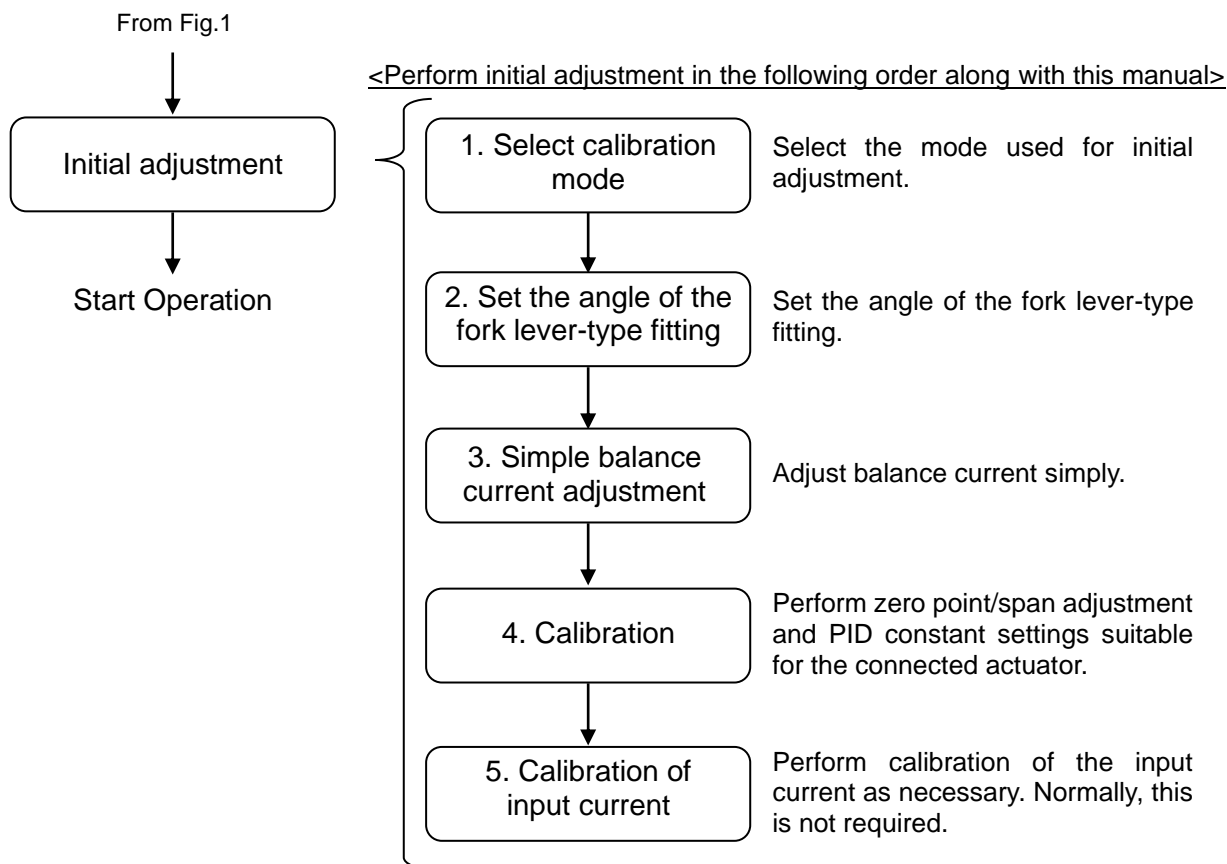

Fig. 2

*1: Refer fig.5 of “■Switching HART Communication Function” for details.

*2: Refer “■Operation” for details of operation.

Operating Principle

Operation principle is the same as basic type. Refer Operation manual “SMART POSITIONER (No.:DIG-31900-OM002)”.

Mounting

Mounting of IP8101 Smart Positioner is the same as basic type. Refer Operation manual “SMART POSITIONER (No.:DIG-31900-OM002)”.

Piping

Piping of IP8101 Smart Positioner is the same as basic type. Refer Operation manual “SMART POSITIONER (No.:DIG-31900-OM002)”.

Warning

1. Refer 375/475 field communicator manual from EMERSON for 375/475 field communicator usage.
2. Refer Operation manual "SMART POSITIONER (No.:DIG-31900-OM002)" for electric wiring method of the positioner.

Electric Wiring for Positioner

Refer Operation manual "SMART POSITIONER (No.:DIG-31900-OM002)".

375/475 Field Communicator Wiring

375/475 field communicator is wired according to fig. 3. 375/475 field communicator is connected parallel to the positioner input current line.

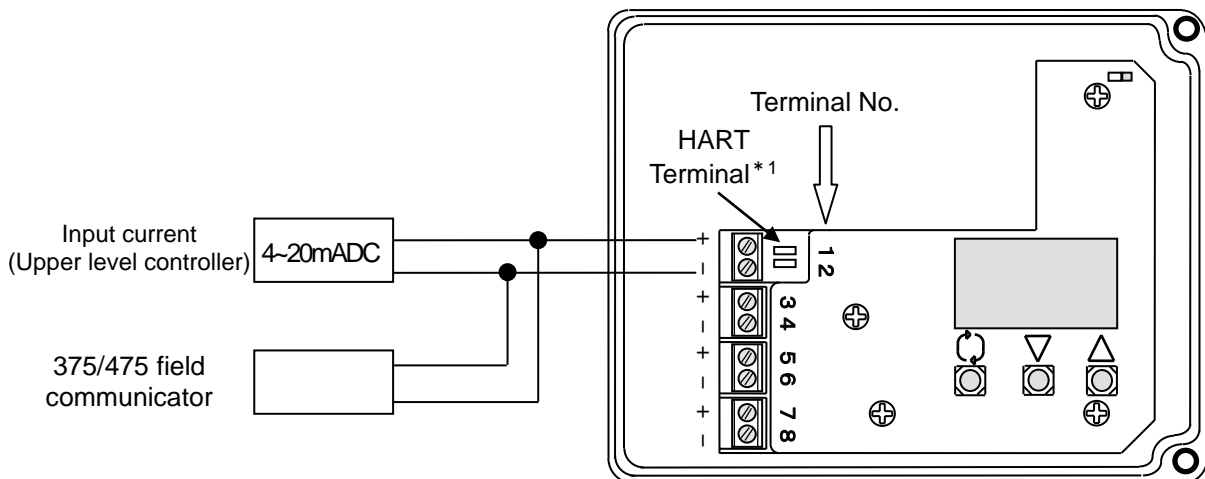

Fig. 3

*1: 375/475 field communicator can be connected. Recommended to use for brief operation check such as maintenance.

Before Starting HART Communication

Positioner's LCD Display During HART Communication

During HART communication of the positioner, communication display on the positioner's LCD flashes (See fig.4). Correctness of HART communication can be checked by checking LCD.

*1: Even during 375/475 field communicator, the communication display does not flash if commands from 375/475 field communicator and the data from the positioner are not sent.

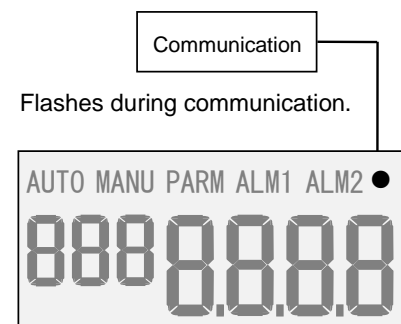

Fig. 4

■ Switching HART Communication function

HART communication function can be turned ON/OFF by HART switch. For HART communication, turn on the switch. To cut HART communication signal on the field, turn OFF the switch.

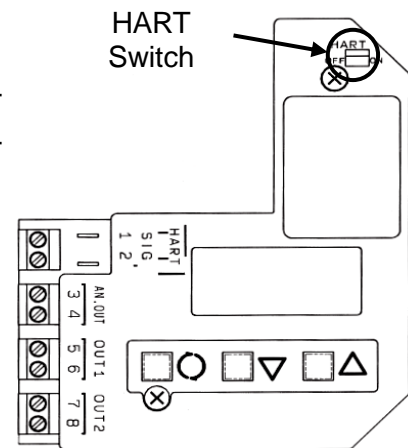

Fig. 5

HART Communication Method

⚠ Caution

Confirm followings before starting communication

1. IP8101 Smart Positioner is supplied with 4 to 20mADC of input current.
2. 375/475 field communicator wiring is arranged.

■ Procedure to Start HART Communication

Wire 375/475 field communicator to input the input current to IP8101 Smart Positioner, and turn on the power supply of 375/475 field communicator. After starting 375/475 field communicator's OS, synchronization with the smart positioner automatically starts *1,*2.

*1: Depends on 375/475 field communicator's setting, polling address other than "0" may not be read. In this case, change 375/475 field communicator setting referring 375/475 field communicator operation manual from EMERSON.

*2: If a message "PRESS ANY KEY TO TERMINATE" appears when HART communication starts and return to initial display, potentiometer may be disconnected, or terminal is pulled off. Ensure no irregularity on the potentiometer.

Warning

1. Before starting initial setting, mount, pipe and wire the positioner referring the operation manual "SMART POSITIONER (No.:DIG-31900-OM002)".
2. Pay attention to your surroundings when performing the initial adjustment because it causes the positioner to automatically move the actuator.
 - (1) Change is not applied until pressing "Send" button after changing operation mode.
After changing the operation mode, press "Send" button.
 - (2) Correct value is not displayed in "Position", "Set point", and "Deviation" if initial adjustment is not correctly made.

■ Change of Parameters for Initial Operation

If 4-20mADC of input current is applied after purchase without adjustment after mounting, positioner can neither be started, nor moved on to auto mode *¹,*². Perform initial adjustment according to procedure below. Initial adjustment can be made with 4 to 20mADC of input current *³. Error may be detected after adjustment. In this case, keep adjusting referring countermeasure of "■ Error Status List".

*1: Until the initial adjustment is complete, the positioner can have each parameter setting, but cannot be operated.

*2: For initial adjustment of HART communication, do not press any button on the positioner. If the operation mode is changed local mode before initial adjustment is completed, mode can not be switched to auto mode by button operation. That is, mode can not be returned to remote mode, and initial adjustment with HART communication can not be made. This case, cut the input signal once, and restart the adjustment.

*3: Do not change the input current during the parameter adjustment.

■ Initial Adjustment

1. Selection of parameter mode

Calibration is available only during parameter mode. Before calibration, change operation mode to parameter mode referring procedure below. Do not forget to press "Send" button after changing the mode to make the change valid.

< Setting method >

Device set up → Detailed set up → Set up → Calibration → Oper Mode → Pm

[Menu Tree No.: 1-3-5-5-1]

2. Adjustment of fork lever-type fitting angle

Adjust the angle of the fork lever-type fitting connected to the positioner fork pin unit. Confirm that the actuator operates within -60 to 60 Deg on the display*4.

< Adjustment method >

Device set up → Detailed set up → Set up → Calibration → Angle

[Menu Tree No.: 1-3-5-5-3]

No.	Procedure
1	OUT1 output is 0MPa*5, and confirm that the actuator is at the end. Ensure the fork pin unit does not interfere the body when "Angle" is -60 Deg or more, and 60Deg or less.
2	Rotate the pilot valve unit auto/manual switch by approx. 1/8 turn for manual direction. Actuator rotates, so attention should be taken. *6
3	OUT1 output becomes max., and the actuator open degree OUT1 becomes end position which is the opposite of item 1 above. And, Ensure the fork pin unit does not interfere the body when "Angle" is -60 Deg or more, and 60Deg or less.
4	When "99Deg" is displayed at both end, the fork lever fitting angle is out of -60 to 60Deg. Readjust the fork lever fitting fixed position.
5	After confirmation, turn the auto/manual switch to auto direction to tighten properly.

*4: The positioner standard stroke is a rotational angle of 60 to 100°. Actuators with a rotating angle of less than 60° or over 100° are not available.

*5: A Description of pressure gauges mounted on the positioner are as shown in Fig. 6.

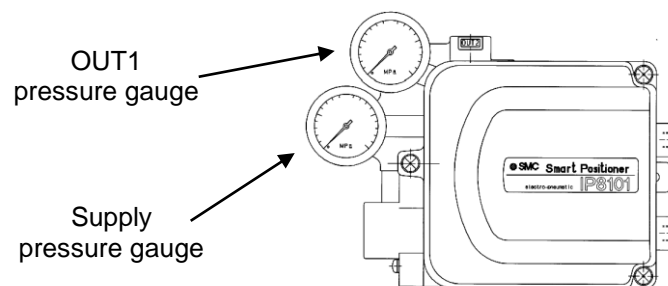

Fig. 6

*6: Auto and manual mode can be switched by rotating the pilot valve unit auto/manual switch screw to the manual (M) side as shown in Fig. 7. A small stopper screw in the top is to prevent loosening and must not be tampered with or loosened. Also, a sensitivity holding screw is set prior to factory shipment and must not be accidentally rotated.

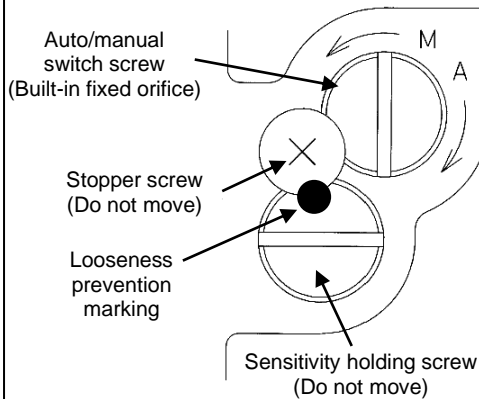

Fig. 7

- Be sure to normally tighten the screw to the auto side (A) when the positioner is operated with an input current.
 - Supply pressure and the OUT1 output are connected by rotating the Auto/Manual changeover screw towards M.
 Manual stroke adjustment of the diaphragm valve and single acting actuator can be adjusted by using the supply pressure setting reducing valve Mode switching is available by approx. 1/8 turn. Keep the rotation within 1/4 to 1/8 turn.

3. Simple balance current adjustment

Adjust the torque motor balance current simply.

< Adjustment >

Device set up → Detailed set up → Set up → Calibration →

Simple Bal Cur

[Menu Tree No. : 1-3-5-5-4]

A

No.	Procedure
1	“Now positioner is forcibly set to 50% current into the torque motor. Do you adjust the screw of torque motor already?” is displayed. Check OUT1 port pressure gauge. When the pressure is 0MPa or more, turn the balance adjustment screw counterclockwise until displayed pressure becomes 0MPa*7.
2	Turn the balance adjustment screw gradually clockwise referring OUT1 port pressure gauge. Stop the balance adjustment screw rotation when exhaust noise is changed, OUT1 pressure becomes rising, but not reach supply pressure.
3	After adjustment, press “OK” to completed easy balance current adjustment mode.

*7: For the balance adjusting screw position, refer to Fig. 8. Adjustments must be made with a flat blade driver. Counterclockwise rotation decreases pressure and clockwise rotation increases pressure.

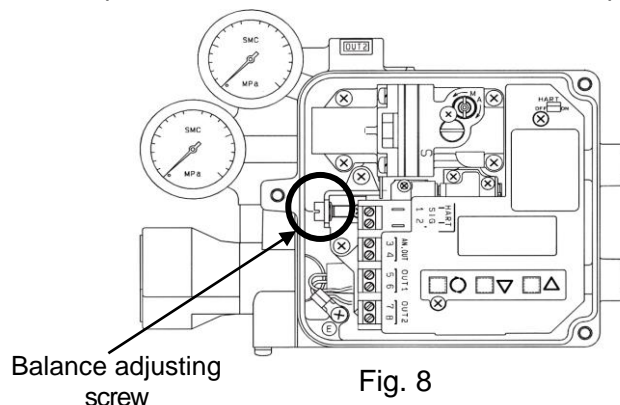

Fig. 8

4. Calibration

Automatically perform zero point / span adjustment and PID constant *8.

< Adjustment >

Device set up → Detailed set up → Set up → Calibration → Span Calibration → Full Calibration

[Menu Tree No. : 1-3-5-5-5-1]

No.	Procedure
1	“Calibration Start?” is displayed. Press “OK” after confirming no danger exists even if actuator starts operation *9.
2	Zero/span adjustment starts and operates automatically *10. “Now Span Calibration is Busy” is displayed.
3	After actuator operation stopped, confirm “Cal Error States”. If “No Error” is displayed, adjustment is completed.

*8: Actuators which take 1 sec. or more per degree after beginning to move can not normally be provided with span adjustment. Such actuators cannot be combined with this positioner, and this fact should be noted.

Warning

*9: When “OK” is pressed, the actuator is fully opened or closed, so avoid touching the actuator or positioner to prevent injuries. Also, the actuator operates during adjustment and neither it nor the positioner should be touched until adjustment is completely finished.

*10: Adjustment might take up to 2min. Actual time will vary depending on the actuator capacity.

Readjust according to the following procedure if the “No Error” is not displayed after the adjustment, which means it has not been performed correctly.

< “Balance current” is displayed in error status *11 >

No.	Procedure
1	When “Balance current” is displayed, confirm balance current according to “Balance current confirmation” *12.
2	After turning the balance adjustment screw so that displayed value becomes “0”. Then, automatically adjust PID according to “PID adjustment”.
3	When “No Error” is displayed in “Cal Error States” after automatic adjustment, adjustment is completed.

*11: When the balance current is confirmed, figure from -7 to +7 is displayed. The closer to “0”, the more correct the adjustment is. When the actuator open degree is out of 50+/-2%, “+99” or “-99” is displayed. If the value is positive, turn the adjustment screw clockwise, if negative, counterclockwise so that the displayed value becomes “0”. If balance adjustment screw is turned, it takes a few seconds for adjustment condition to be stabilized. Do not turn the balance adjustment screw until the result is fixed.

< "Hunting" is displayed in error status >

No.	Procedure
1	When hunting occur during adjustment, PID constant is automatically adjusted and focused.
2	After hunting focused, automatically confirm the balance current.
3	"Hunting" is displayed in "Cal Error States"*12.

*12: Make adjustment referring "■ Troubleshooting and Error Status"

5. Input current calibration

Normally, input current dose not need to be calibrated. If input values (S value) have a displacement in auto mode after the above adjustment, input current of 4 to 20mA DC can be calibrated.

< Adjustment >

Devicd set up → Detailed set up → Set up → Calibration → Input 4-20mA Cal
[Menu Tree No.: 1-3-5-5-6]

A

A

No.	Procedure
1	"WARN-Loop should be removed from automatic control" will be displayed. Press "OK".
2	"Connect reference meter" will be displayed. Press"OK".
3	"Please adjust the loop current to 4mA"and then"Is the loop current stable at 4mA" will be displayed. Enter the input current of 4mADC.Press"OK".
4	"Do you want to calibrate the loop-current?" will be displayed. Press "OK". *13
5	"Please adjust the loop current to 20mA"and then "Is the loop current stable at 20mA" will be displayed. Enter the input current of 20mADC.Press"OK".
6	"Do you want to calibrate the loop-current?" will be displayed. Press "OK". *13
7	"NOTE-Loop may be returned to automatic control" will be displayed. Press "OK".

*13: When adjustment does not end normally, input signal possibly be largely displaced from 4mADC or 20mADC. Ensure correct output of the output current from the controller.

Operation

HART communication provides remote mode operation and local mode operation. Refer table 3 for details of each operation. Present operation can be confirmed by Device set up → Detailed set up → Set up → Operation (Menu Tree No.: 1-3-5-1). For details of operation shift, refer “**■**Operation and Operation Mode Shift”.

Table 3

Operation	Content
Remote mode	HART communication mode
Local mode	HART communication is not available. Operation is changed by pressing button on the positioner. For details, refer “ ■ Operation and Operation Mode Shift”.

Operation Mode

Auto mode, manual mode, and parameter mode are available for the positioner. Refer table 4 for details. Currently, operation mode can be confirmed with Device set up → Detailed set up → Set up → Detail setup → Opr Mode (Menu Tree No.: 1-3-5-7-1).

Table 4

Operation mode	Content
Auto mode	Refer “ ■ Auto Mode Operation”
Manual mode	Refer “ ■ Manual Mode Operation”
Parameter mode	Set and change parameters

Operation and Operation Mode Shift

■ Operation Shift

Positioner's operation shifts as in fig. 9 and 10.

< When initial adjustment is not made *1 >

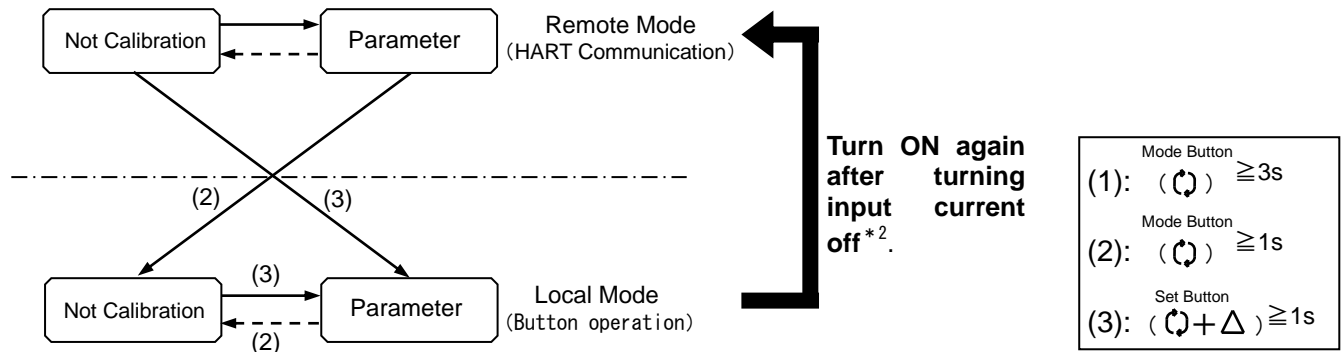

Fig. 9

*1: Initial adjustment is not performed. Mode can not shift to auto mode.

*2: When return to local mode to remote mode, turn off positioner's input current, then turn it on again. When HART communication starts, mode automatically changed to remote mode.

< When initial adjustment is completed >

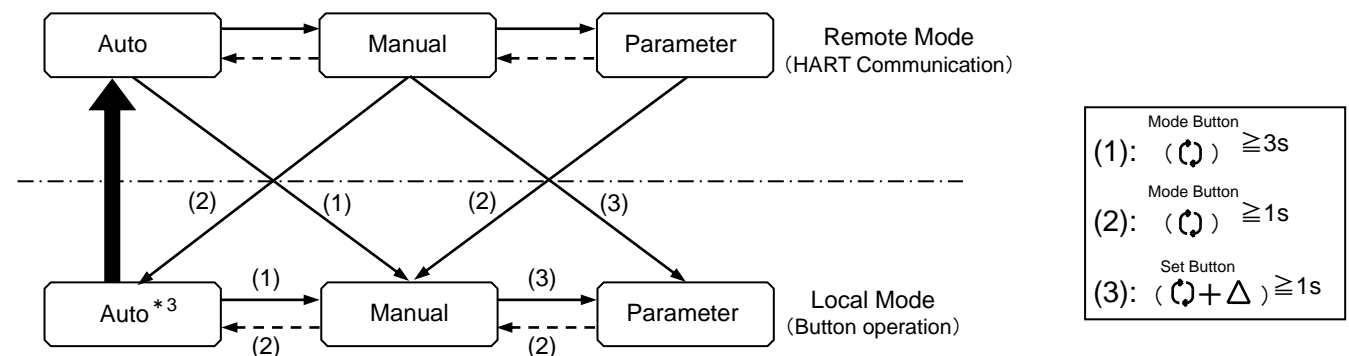

Fig. 10

*3: To return from local mode to remote mode, change the mode to auto mode at local mode (button operation). After the change, the mode is automatically changed to remote mode.

Auto Mode Operation

■ Auto Mode

Use an auto mode if controlling an actuator by an input current as a smart positioner.

■ Operation Confirmation During Auto Mode

When operated with auto mode, change the mode to auto mode. During auto mode, operation can be confirmed with “Dynamic Variables”.

< Operation confirmation method >

Device set up → Detailed set up → Set up → Dynamic Variables [Menu Tree No.: 1-3-5-3]

Manual Mode Operation

■ Manual Mode

Normally, this positioner is used with auto mode. During maintenance, random valve open degree can be set with manual.

■ Operation During Manual Mode

To use with manual mode, change the mode to manual mode. During manual mode, input random value to adjust valve open degree.

< Operation method >

Device set up → Detailed set up → Set up → Manual operation → Set Signal
[Menu Tree No.: 1-3-5-4-2]

⚠ Caution

1. Parameter can be changed only with parameter mode. No other mode can change parameters.
2. When changing to parameter mode, do not forget to press "Send". Changing parameter without pressing "Send" button lead to cause operation failure.

■ Parameter Code Detail

For details of parameter code, refer operation manual "SMART POSITIONER (No. DIG-31900-OM002)".

■ Actuator Type

Actuator type

This parameter is fixed when shipped out of the factory. User can not change it.

< Setting confirmation >

Devicd set up → Detailed set up → Set up → Actuator → Actype
[Menu Tree No. : 1-3-5-6-1]

■ Detail Set Up

Act direction

Customer can select direct or reverse.

< Setting method >

Devicd set up → Detailed set up → Set up → Detail setup → Act Dir [Menu Tree No. : 1-3-5-7-2]

No.	Procedure
1	Select "Direct" or "Reverse"

Split range

With or without split range can be selected. When split range is used, set values can be changed.

< Setting method >

Devicd set up → Detailed set up → Set up → Detail setup → Split Range
[Menu Tree No.: 1-3-5-7-3]

No.	Procedure
1	Select "Split Range" (Enable) or (Disable).
2	Set lower limit within 0.0 to 80.0% with "SR Low".
3	Set upper limit within 40.0 to 125.0% with "SR High".

Manual span

With or without zero/span setting can be selected. When zero/span is used, set values can be changed.

< Setting method >

Devicd set up → Detailed set up → Set up → Detail setup → Manual Span

[Menu Tree No.: 1-3-5-7-4]

No.	Procedure
1	Select "Manual Span" (Enable) or (Disable).
2	Set lower limit within -20.0 to 60.0% with "MS Low"
3	Set upper limit within 40.0 to 120.0% with "MS High".

Enforced open/close

Forced fully close/fully open can be selected. When this is used, set values can be changed.

< Setting method >

Devicd set up → Detailed set up → Set up → Detail setup → Enforced Opn/Cls

[Menu Tree No.: 1-3-5-7-5]

No.	Procedure
1	Select "Opn/Cls" (Enable) or (Disable).
2	Set lower limit within 0.0 to 10.0% with "Cls Value"
3	Set upper limit within 90.0 to 100.0% with "Opn Value".

Dead band

Set dead band.

< Setting method >

Devicd set up → Detailed set up → Set up → Detail setup → Dead Band

[Menu Tree No. : 1-3-5-7-6]

No.	Procedure
1	Change within 0.0 to 10.0%.

Valve characteristics

Valve open degree character can be selected. Polygobnal line with 11 dots can be set for custome setting.

< Setting >

Devicd set up → Detailed set up → Set up → Detail setup → Valve Char

[Menu Tree No.: 1-3-5-7-7]

No.	Procedure
1	Select valve character function with "Valve Char"
2	If "Custom" is selected in item 1, change items within -20.0 to 120.0% with "Custom Char".

PID set

PID constant can be set. Normal direction(Dir) and reversed direction(Dir) can be independently set. PID constant can be automatically set during span adjustment, and (Dir) and (Rev) can be automatically set. For adjustment, refer "■Improved Controllability".

< Setting >

Devicd set up → Detailed set up → Set up → Detail setup → PID Set

[Menu Tree No.: 1-3-5-7-8]

No.	Procedure
1	Set P constant in normal direction(Dir) with "Kp Dir"
2	Set I constant in normal direction(Dir) with "Ki Dir".
3	Set D constant in normal direction (Dir) with "Kd Dir".
4	Set P constant in reversed direction(Rev) with "Kp Rev".
5	Set I constant in reversed direction(Rev) with "Ki Rev".
6	Set D constant in reversed (Rev) with "Kd Rev".

PID easy set

Possible to change PID constant easily. For change amount when set value is changed, refer table 5. If adjustment is not necessary, set value shall be "0".

< Setting >

Devicd set up → Detailed set up → Set up → Detail setup → PID easy Set

[Menu Tree No.: 1-3-5-7-9]

No.	Procedure
1	Change the amplification of P constant with "Kp change".
2	Change the amplification of I constant with "Ki change"
3	Change the amplification of D constant with "Kd change"

Table 5

	Amount of change when set value is increased/ decreased by 1	
	Set value is 0 or more	
Prop. gain	±10%	Prop. gain
Integ. time	±50%	Integ. time
Deffer. time	±10%	Deffer. time

Alarm set

Alarm 1 and 2 can be selected. If they are set, the set value can be set.

< Setting >

Devicd set up → Detailed set up → Set up → Detail setup → Alarm Set

[Menu Tree No.:1-3- 5-7-10]

No.	Procedure
1	Setting (Enable) or (Disable) can be selected with "Out1 Sel".
2	If setting (Enable) is selected in item 1 above, select lower limit(Pv Low) or upper limit alarm(Pv High) of alarm 1 with "Out1 Mode".
3	Change set value within -20 to 120.0% with "Out1 Limit".
4	Select setting (Enable) or no setting (Disable) with "Out2 Sel".
5	If (Enable) is selected in item 4, select lower limit of(Pv Low) or upper limit (Pv High) of alarm 2 with "Out2 Mode .
6	Change set value within -20 to 120.0% with "Out2 Limit".

A

A

Analog set

Possible to select proportional output(Direct) and reverse output of analog output, and confirm current value.

< Setting >

Device set up → Detailed set up → Set up → Detail setup → Analog Set

[Menu Tree No.: 1-3-5-7-11]

No.	Procedure
1	Select output method of analog output with "AO Mode".
2	If necessary, confirm current analog output value with "Position".

■ Calibration

Angle *1

Adjust the mount angle of fork lever fitting.

*1: For adjustment procedure, see "(2) Angle adjustment of fork lever fitting" of "■ Initial Adjustment".

Simple Balance Current *2

Adjust the balance current of the torque motor.

*2: For adjustment procedure, see "(3) Simple balance current adjustment" of "■ Initial Adjustment".

Span Calibration *3

Perform zero span adjust and auto adjustment of PID constant. Depends on error status condition, calibration type can be selected from full calibration, span calibration, PID+balance adjustment.

*3: For display items, refer "■ Troubleshooting and Error Status".

< Full Calibration *4 >

With full calibration, zero span adjustment, and PID adjustment can be performed simultaneously. At initial calibration, only full calibration can be selected.

*4: For adjustment procedure, see "4. Calibration" of "■ Initial Adjustment".

Adjust zero point / span. Unlike Full Calibration, PID constant automatic setting is not performed. PID set once remains valid. This function is used when only zero-span adjustment is necessary.

< Adjustment >

Device set up → Detailed set up → Set up → Calibration → Span Calibration → Span Calibration
[Menu Tree No.: 1-3-5-5-5-2]

No.	Procedure
1	"Calibration Start?" is displayed. After confirming no possibility of hazard even if the actuator operate, press "OK" * ⁹ .
2	Zero span adjustment starts and operates automatically. "Now Span Calibration is Busy" is displayed.
3	After actuator operation stopped, confirm "Cal Error Status". If display says "No Error", adjustment is completed.

<PID+BC adjustment>

PID is automatically adjusted. Not like full calibration, zero span is not adjusted. This becomes available when balance current adjustment error(Balance current) is displayed.

< Setting >

Device set up → Detailed set up → Set up → Calibration → Span Calibration → PID+BC adjustment
[Menu Tree No.: 1-3-5-5-5-3]

A

No.	Procedure
1	"Calibration Start?" is displayed. After ensuring no possibility of hazard even after actuator operate, press "OK",
2	PID automatic adjustment starts, and operates automatically. "Now Span Calibration is Busy" is displayed.
3	Confirm "Cal Error Status" after actuator operation stopped. If display is "No Error", adjustment is completed.

Input 4-20mA Calibration*⁶

4mADC and 20mADC of input current can be calibrated. This is not necessary usually.

*6: For adjustment procedure, see "5. Input current calibration" of "■Initial Adjustment".

Balance Current^{*7,*8}

Confirm the torque motor balance current adjustment condition with the value. When display is "0", balance current is properly adjusted. Other than "0", readjust the balance current so that the value becomes "0".

< Setting >

Device set up → Detailed set up → Set up → Calibration → A
Balance Current
[Menu Tree No.: 1-3-5-5-7]

No.	Procedure
1	Select "Enable Bal Cur". "Do you want to monitor the balance current?" is displayed. Press OK button.
2	"WARN!: Actuator will move to 50%" is displayed. After confirming no possibility of hazard even if the actuator operate, press OK button ^{*9} .
3	Present balance current adjustment value is displayed in "Bal curlevel". If value other than "0" is displayed, turn the adjustment screw to readjust. ^{*10,*11} .
4	After confirmation and adjustment, select "Disable Bal Cur" to release balance current confirmation mode. "Do you want to quit the Balance Current Monitor? is displayed. Press "OK" button.
5	"WARN!: Actuator will move to 0%" is displayed. After confirming no possibility of hazard even if the actuator operates, press OK button.
6	Ensure "BC monitor is?" is "invalid".

*7: This adjustment becomes available only after initial adjustment.

*8: This function may not work due to hunting if user changes PID constant.

Warning

*9: The actuator operate abruptly after holding down the "OK" button. Do not touch the actuator and positioner.

*10: See fig.9 for the balance adjusting screw location.

*11: The smaller the absolute value of displayed value, the closer to optimum condition. The larger, the farther from optimum condition. If displayed value is positive number, turn the balance adjustment screw clockwise, if negative, counterclockwise to make displayed value "0". When turn the balance adjustment screw, +99 or -99 is displayed for confirming adjustment condition. Do not turn the balance adjustment screw until the result is fixed.

Output 4-20mA Calibration

Analog output is confirmed and calibrated. Establish the environment in which analog output is confirmed.

<Loop test>

Confirm analog output value by output of simulated current. 4mADC, 20mADC, or Other can be selected. Output can be confirmed within 4 to 20mADC in (Other).

< Confirmation >

Devicd set up → Detailed set up → Set up → Calibration → Output 4-20mA Cal → Loop test
 [Menu Tree No.: 1-3-5-5-8-1]

No.	Procedure
1	Select simulated current to confirm. "WARN-Loop should be removed from automatic control" is displayed. Press "OK".
2	"Fld dev output is fixed at OmA" is displayed. Confirm analog output value. Press OK if simulated current is not different to complete. If difference is found, make adjustment with <D/A trim>.
3	Press "End", "Returning fld dev to original output" will be displayed. "NOTE-Loop may be returned to automatic

<D/A trim>

Analog output can be calibrated. This is used for adjustment when difference is found in simulated current and analog output display during loop test.

< Confirmation >

Devicd set up → Detailed set up → Set up → Calibration → Output 4-20mA Cal → D/A trim
 [Menu Tree No.: 1-3-5-5-8-2]

No.	Procedure
1	"Connect reference meter.", "Setting fld dev output to 4mA" is displayed. Confirm the ammeter display. Input displayed current value.
2	Press "Yes" when ammeter display shows 4mADC. If not, press "No". Repeat operation in item 1 above until the display shows 4mADC.
3	20mADC is put out. Check the ammeter to input displayed current value.
4	Repeat operation in item 3 until the ammeter displays 20mADC.
5	"Returning fld dev to original output" will be displayed. "NOTE-Loop may be returned to automatic control" will be displayed automatically. Press "OK".

A

A

A

■Parameter Setting Default Value List

To return changed parameter to ex-factory data, input the parameter setting default value. Parameter setting default value is the same as basic type. Refer operation manual “SMART POSITIONER (No.:DIG-31900-OM002)”.

Improved Controllability

PID constant of this positioner is automatically set during calibration. However, operation speed is delayed or controllability becomes unstable due to the used actuator size. These symptoms can be improved by changing PID constant. Refer operation manual “SMART POSITIONER (No.:DIG-31900-OM002)”.

Hot Key

When operating IP8101 smart positioner with 375/475 field communicator, commands in table 4 are registered in Hot Key. Use Hot Key if necessary. Refer 375/475 field communicator for usage of Hot Key.

Table 6

Registered key	Content	Note
Opr Mode	Change operation mode	-
Split Range	Set split range	Refer “■Parameter Code Detail” of operation manual “SMART POSITIONER (No.:DIG-31900-OM002)”.

Scale Plate Adjustment

When dial plate type is selected, the adjustment of the dial plate is necessary. Adjust the dial plate according to the operation manual “SMART POSITIONER (No.:DIG-31900-OM002)”.

Maintenance and Check

Maintenance item of HART communication type is the same as basic type. Refer operation manual “SMART POSITIONER (No.:DIG-31900-OM002)” for maintenance items.

Instructions

Precautions of HART communication type is the same as basic type. Refer operation manual “Smart Positioner (No.:DIG-31900-OM002)” for precaution on instruction.

Compressed Air Cleaning Equipment

Refer operation manual “SMART POSITIONER (No.:DIG-31900-OM002)” for operation manual.

Status Error

Status error can be displayed during the operation of smart positioner. Table 7 shows status error and countermeasures. Confirm when status error is displayed.

Table 7

Display	Content	Countermeasure	Ref. page
A reset or self test of the field device has occurred, or power has been removed and reapplied.	- After stating communication with 375/475 field communicator, input current was cut off while data is not communicated with a positioner. Communication was resumed after input current was supplied	- Use the positioner as usual after grasping the cause of input current cut-off.	-
Field device has more status available.	- Either of "Device fault", "Mechanical failure", "ADC failure", "Out1 alarm", "Out2 alarm", or "OprTime expired" happens.	- Check each status abnormality, and troubleshoot as shown on "Countermeasure".	-
Device fault	- Circuit board shorts	- Contact SMC	-
Mechanical failure	- Potentiometer is damaged - Potentiometer terminal is disconnected	- Confirm the connection of potentiometer terminal.	-
ADC failure	- AD converter in CPU has non conformance.	- Return to SMC	-
Out1 alarm	- Alarm output 1 exceeds set value(or less than it).	- Confirm open degree of the actuator	10
Out2 alarm	- Alarm output 2 exceeds set value(or less than it).	- Confirm actuator open degree	10
OprTime expired	- Accumulated operation time(Acc Opr Time) reaches maintenance time set by Ment Interval, or exceeded.	- Perform maintenance, and input the latest maintenance date. Accumulated time is reset.	10

■ Troubleshooting

If any irregular operation is found during the usage of this positioner, perform countermeasures in the table 8 of troubleshooting. For troubles due to cause other than HART communication, refer operation manual “SMART POSITIONER (No.:DIG-31900-OM002)”.

Table 8

Content	Possible cause	Countermeasure	Page to refer
Communication not available	- 375/475 field communicator is not connected	- Connect input current line with 375/475 field communicator	15
	- Positioner's polling address is set other than "0".	- Change the setting of 375/475 field communicator	9
	- Input current is not stabilized	- Ground the positioner	-
	- Upper status controller does not match	- Change upper status controller	-
	- Input current is not applied	- Apply correct input current(4 to 20mADC)	15
	- HART switch is turned off	- Turn ON ON/OFF switch	16
	- Other cause	- Contact SMC	-
Setting change not available	- Operation is in local mode	- Change operation mode to remote mode	16,17
	- Other cause	- Contact SMC	-

■ Error Status List [Menu Tree No.: 1-3-5-5-2]

Table 9 shows errors detected with error status after positioner adjustment. If error is detected after adjustment, make readjustment according to countermeasure. It should be noted that “Actuator No Move”, “Angle Range”, “Time Out” can not be moved to auto mode unless correctly ended after recalibration.

Table 9

Error display	Type of error	Possible cause	Countermeasure of positioner	Countermeasure of 375/475 field communicator
No Error	Normal end	-	- No action necessary	- No action necessary
Actuator No move	Actuator operation failure	- Supply pressure is not applied	- Apply supply pressure	- After performing Countermeasure of positioner, calibrate the communicator with “Full Calibration”.
		- Actuator is not connected	- Confirm the connection between the positioner and the actuator.	
		- Easy balance adjustment is not performed	- Perform easy balance adjustment	
		- Disconnection of potentiometer output line - Disconnection of torque motor	- Ensure potentiometer output line and torque motor line are not disconnected, and they are connected to the terminal.	
		- Too large actuator capacity	- Connect booster relay	
Angle Range	Fork lever installation angle failure	- Fork lever installation position exceeds -60 to 60 degree which is angle adjustment range.	- Readjust the angle. Refer operation manual of basic type (No. : DIG-31900-OM001)	- After performing Countermeasure of positioner, calibrate the communicator with “Full Calibration”.
		- Fork lever is not tightened enough	- Tighten the fork lever set screw properly	
		- Actuator rotation angle exceeds standard stroke range(60 deg. to 100deg.).	- Ensure actuator rotation angle is within 60deg. to 100deg. If rotation is out of this range, select actuator again.	

Error display	Type of error	Possible cause	Countermeasure of positioner	Countermeasure of 375/475 field communicator
Hunting	Hunting detected	- Actuator size is small	- No action necessary	- Switch to auto mode to change the input current in order to confirm the hunting of the actuator. If hunting is present, focus it by PID adjustment. Refer operation manual or basic type(Doc. No.:DIG-31900-OM002).
		- Piping has orifice(speed controller) etc.	- Verify the actuator size again - Remove the orifice in piping	- Calibrate with "Full Calibration" after performing countermeasure of the positioner.
Balance Current	Balance current adjustment failure	- Balance current adjustment condition is not optimum	- Adjust the balance adjusting screw (See Fig. 9) so that the balance current on the display becomes "0".	- Calibrate with "PID+Balance" after performing countermeasure of the positioner.
Hunting Time Out	Hunting is not focused.	- For possible causes, countermeasure of positioner side, and 375/475 field communicator, refer error display "Hunting".		
Time Out	Balance current confirmation failure.	- Easy balance adjustment is not performed.	- Adjust the balance adjusting screw by easy balance adjustment	- Calibrate with "Full Calibration" after performing countermeasure of the positioner.

How to Order

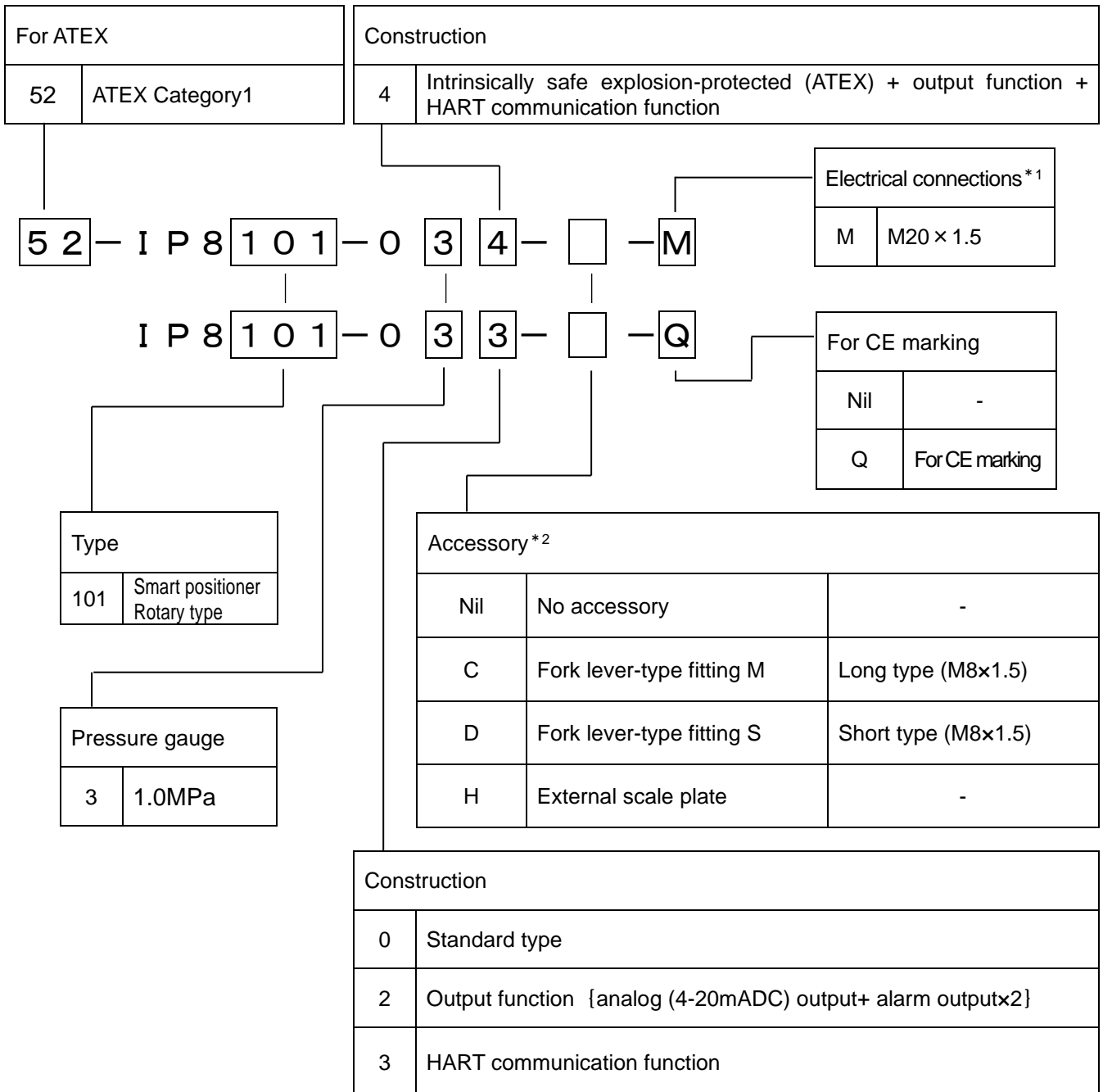

*1 : Please consult about NPT thread or G thread of electrical connections.

*2 : If two or more accessories are required, the part numbers should be made according to alphabetical order. <Ex>IP8101-030-CH

Drawing

For exterior dimensions of IP8101 Smart Positioner, refer operation manual "SMART POSITIONER (No.:DIG-31900-OM002)".

Revision history		
A	18/5/2010	Error in writing was corrected.
B	24/5/2024	Additional menu tree. (Compatible with HART 7) Change of Safety Instructions

SMC Corporation

Tel: + 81 3 5207 8249 Fax: +81 3 5298 5362
URL <https://www.smcworld.com>

Note: Specifications are subject to change without prior notice and any obligation on the part of the manufacturer.
© SMC Corporation All Rights Reserved