



Operation Manual

PRODUCT NAME

LOCK UP VALVE 3-PORTS

MODEL/ Series

IL220

SMC Corporation

Table of Contents

Instructions for your Safety	1~2
1. Summary	3
2. Specification	3
3. Operation Principle	3~4
4. Transportation and Storage	5
5. Mounting and Piping	5
6. Precautions in Using	6
7. Maintenance	7
8. Example Application	8
9. Troubleshooting	9
10. Spare Parts List	9
11. Drawing	10~11



Safety Instructions

These safety instructions are intended to prevent hazardous situations and/or equipment damage. These instructions indicate the level of potential hazard with the labels of “**Caution**,” “**Warning**” or “**Danger**.” They are all important notes for safety and must be followed in addition to International Standards (ISO/IEC)^{*1)}, and other safety regulations.

*1) ISO 4414: Pneumatic fluid power - General rules and safety requirements for systems and their components
ISO 4413: Hydraulic fluid power - General rules and safety requirements for systems and their components
IEC 60204-1: Safety of machinery - Electrical equipment of machines - Part 1: General requirements
ISO 10218-1: Robots and robotic devices - Safety requirements for industrial robots - Part 1: Robots etc.

	Danger	Danger indicates a hazard with a high level of risk which, if not avoided, will result in death or serious injury.
	Warning	Warning indicates a hazard with a medium level of risk which, if not avoided, could result in death or serious injury.
	Caution	Caution indicates a hazard with a low level of risk which, if not avoided, could result in minor or moderate injury.

Warning

1. The compatibility of the product is the responsibility of the person who designs the equipment or decides its specifications.

Since the product specified here is used under various operating conditions, its compatibility with specific equipment must be decided by the person who designs the equipment or decides its specifications based on necessary analysis and test results. The expected performance and safety assurance of the equipment will be the responsibility of the person who has determined its compatibility with the product. This person should also continuously review all specifications of the product referring to its latest catalog information, with a view to giving due consideration to any possibility of equipment failure when configuring the equipment.

2. Only personnel with appropriate training should operate machinery and equipment.

The product specified here may become unsafe if handled incorrectly. The assembly, operation and maintenance of machines or equipment including our products must be performed by an operator who is appropriately trained and experienced.

3. Do not service or attempt to remove product and machinery/equipment until safety is confirmed.

1. The inspection and maintenance of machinery/equipment should only be performed after measures to prevent falling or runaway of the driven objects have been confirmed.
2. When the product is to be removed, confirm that the safety measures as mentioned above are implemented and the power from any appropriate source is cut, and read and understand the specific product precautions of all relevant products carefully.
3. Before machinery/equipment is restarted, take measures to prevent unexpected operation and malfunction.

4. Our products cannot be used beyond their specifications. Our products are not developed, designed, and manufactured to be used under the following conditions or environments. Use under such conditions or environments is not covered.

1. Conditions and environments outside of the given specifications, or use outdoors or in a place exposed to direct sunlight.
2. Use for nuclear power, railways, aviation, space equipment, ships, vehicles, military application, equipment affecting human life, body, and property, fuel equipment, entertainment equipment, emergency shut-off circuits, press clutches, brake circuits, safety equipment, etc., and use for applications that do not conform to standard specifications such as catalogs and operation manuals.
3. Use for interlock circuits, except for use with double interlock such as installing a mechanical protection function in case of failure. Please periodically inspect the product to confirm that the product is operating properly.



Safety Instructions

Caution

We develop, design, and manufacture our products to be used for automatic control equipment, and provide them for peaceful use in manufacturing industries.

Use in non-manufacturing industries is not covered.

Products we manufacture and sell cannot be used for the purpose of transactions or certification specified in the Measurement Act.

The new Measurement Act prohibits use of any unit other than SI units in Japan.

Limited warranty and Disclaimer/Compliance Requirements

The product used is subject to the following “Limited warranty and Disclaimer” and “Compliance Requirements”.

Read and accept them before using the product.

Limited warranty and Disclaimer

1. The warranty period of the product is 1 year in service or 1.5 years after the product is delivered, whichever is first.*2)
Also, the product may have specified durability, running distance or replacement parts. Please consult your nearest sales branch.
2. For any failure or damage reported within the warranty period which is clearly our responsibility, a replacement product or necessary parts will be provided.
This limited warranty applies only to our product independently, and not to any other damage incurred due to the failure of the product.
3. Prior to using SMC products, please read and understand the warranty terms and disclaimers noted in the specified catalog for the particular products.

***2) Vacuum pads are excluded from this 1 year warranty.**

A vacuum pad is a consumable part, so it is warranted for a year after it is delivered.

Also, even within the warranty period, the wear of a product due to the use of the vacuum pad or failure due to the deterioration of rubber material are not covered by the limited warranty

Compliance Requirements

1. The use of SMC products with production equipment for the manufacture of weapons of mass destruction (WMD) or any other weapon is strictly prohibited.
2. The exports of SMC products or technology from one country to another are governed by the relevant security laws and regulations of the countries involved in the transaction. Prior to the shipment of a SMC product to another country, assure that all local rules governing that export are known and followed.

1. Summary

Lock up valve is used for switching pneumatic circuit of air source and operation part when an accident of air source and piping in pneumatic process control causes abnormal supplied air, and air pressure lowers below setting pressure.

2. Specification

Signal pressure	Max. 1MPa (Note 1)
Setting pressure range	0.14~0.7MPa (Note 1)
Line pressure	Max. 0.7MPa
Effective orifice (Cv factor)	20mm ² (1.1)
Ambient and fluid temperature	-5~60°C
Port size	Rc 1/4
Differential	0.01 MPa
Mass	700g



Caution

(Note 1) Signal pressure and the set pressure must be different for more than 0.1 MPa. Inadequate differential pressure may increase the bleed amount from the bleed hole because of the wearing of internal part. This may effect on the performance.

3. Operating principles

When signal pressure entering the upper diaphragm chamber is larger than the force by pressing adjusting spring, the diaphragm A moves upward, the exhaust valve is closed, signal pressure enters the lower diaphragm camber, the diaphragm B is a affected, the valve is opened against the spring, and the flow can go from IN1 to OUT.

When signal pressure is lower than the setting pressure, the diaphragm is pushed down and the pressure of lower pressure diaphragm is exhausted from the exhaust valve. Therefore spring A pushes up the piston, and the valve shuts the air circuit being open by the force of spring B. This realizes the air passage from IN2 to OUT.

Pressure is adjusted by the screw.

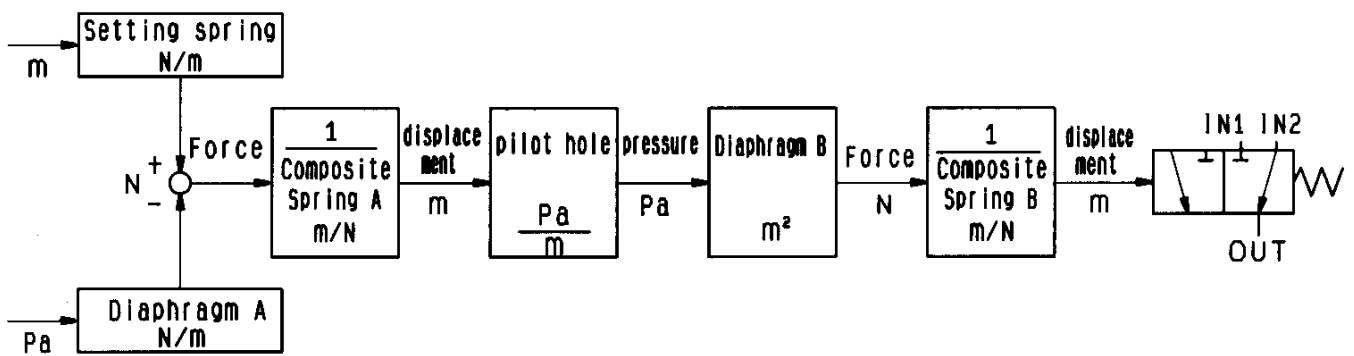
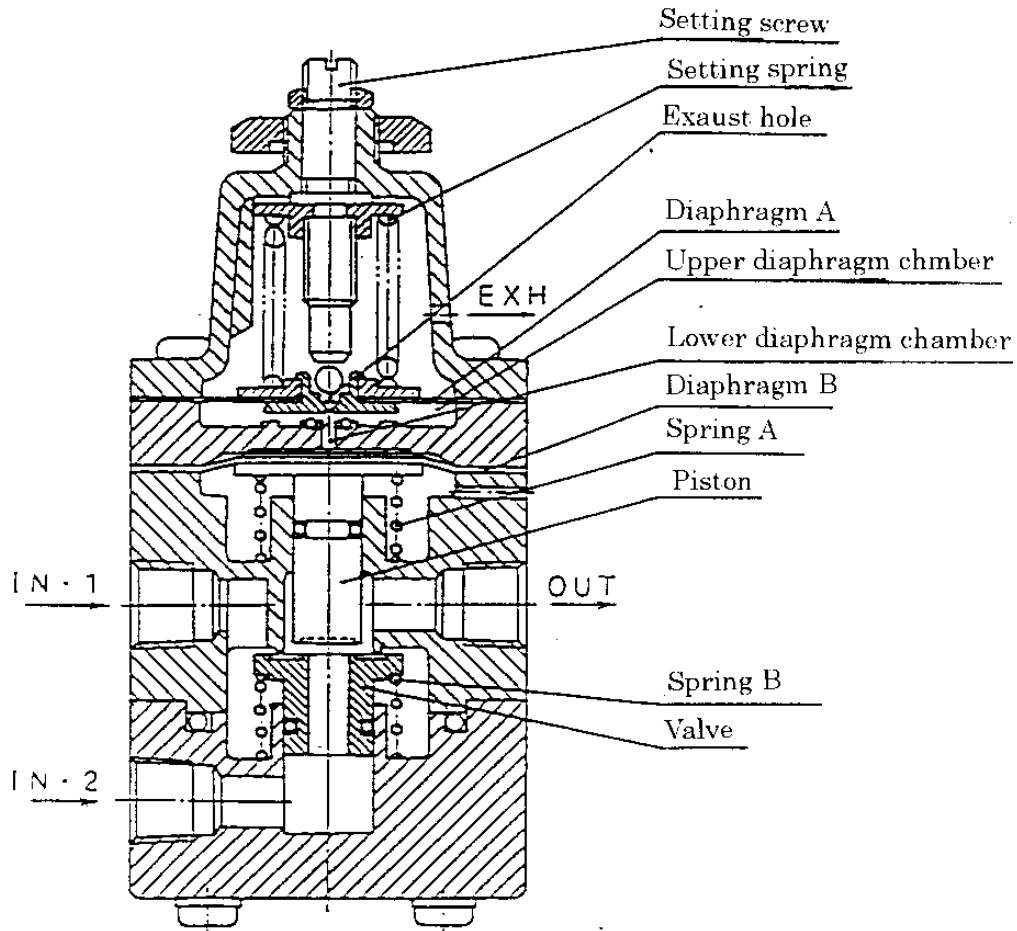

Block diaphragm

4. Transportation and Storage



Warning

- (1) Handle the product with care.
- (2) Do not expose to rain.
- (3) The product is packed in a vinyl bag for shipment to prevent from dust. Avoid taking out of the bag just before piping even after unpacking.
- (4) If the product is kept unpacking for a certain period, select a place where there is no moisture nor corrosive gas.
While the product shipped has been applied specified paint and surface treatment, take care that inappropriate storing environment may cause generating rust.

5. Mounting and Piping



Warning

Precaution for mounting

- (1) Ensure to use a filter for IN line (IN) and signal pressure line (SIG).
- (2) Connect the lock-up valve after flushing piping used.
- (3) The setting pressure increases when the setting screw is turned clockwise and it decreases when the screw is turned counterclockwise.
- (4) Fix by the lock nut when the setting pressure is settled.
- (5) Connect piping not to leak air from piping joints.

Precaution for piping

Thoroughly flush piping to prevent entering foreign matter such as chips, cutting oil and dust before connecting piping.

6. Precautions in using



Warning

Operation

- (1) Do not operate the lock-up valve out of the specifications, because it causes malfunction.
- (2) If lock-up valve failure affecting the system is expected, provide a safety circuit for the system to avoid danger.
- (3) When supplying air pressure fails and it decreases lower than the setting pressure, air source and operating part are shut down, but since the pressure decrease gradually, check line pressure (movement of actuator) constantly.



Warning

Handling

- (1) Excess vibration and impact on the lock-up valve cause failure, that take care handling during transportation and operation.
- (2) If the product is left the site for long time, take measures such as closing a cover and plugging piping ports to avoid direct instruction of rain.
If the case of high temperature and high humidity atmosphere, take measures not to form dews in the internal machines. Especially for packing for export, thoroughly take countermeasures for dew formation.



Warning

Air supply

- (1) Supply clean compressed air whose moisture and dust are removed since there is capillary tubing in the lock-up valve inside. Avoid using a lubricator.
- (2) Avoid using compressed air compressed air containing chemicals, synthetic fluid including organic solvent, salinity, and corrosive gas as it may cause malfunction.



Warning

Environment

- (1) Do not use in environment where the product is exposed to corrosive gas, chemicals, salt water, water or steam.
- (2) Do not operate the product in a location where it is subject to strong vibration and/or shock. For vibration, it should be within 1G 60Hz.

7. Maintenance



Warning

- (1) If handled improperly, compressed air can be dangerous. Maintenance and replacement of unit parts should be performed only by trained and experienced personnel for instrumentation equipment as well as following the product specifications.
- (2) For maintenance, removing lock-up valve or replacing unit parts without dismounting, stop supply pressure and exhaust residual pressure beforehand.
- (3) After installation, repair and disassembling, connect compressed air and perform a proper function test and a leak test. If bleed noise is louder than the initial state or operation is abnormal, stop operation and check if installation is proper or not.



Caution

- (1) Check air leak from piping which compressed air flows. Air leak from air piping could deteriorate characteristics.
Air is exhausted from the bleed port constantly, and this air consumption is essential due to valve structure, so that it is not a problem if the range is within the specification.
Small amount of air leaks from diaphragm (cloth between rubber sheets of diaphragm) and its seating part, but it is within the tolerance.
- (2) Check if supply air is clean or not. If dust, particle, oil, and moisture contained in supply air are entered in the device, it may cause malfunction or failure of lock-up valve, so that regularly examine air preparation equipment.
- (3) When a lock-up valve is disassembled, apply small amount of grease to sliding sections ("O" ring).
Use grease of Toray Silicon SH45 Silicon Grease.
- (4) Examine lock-up valve once a year. Replace deteriorated packing parts such as diaphragms and "O" rings, and units during maintenance.
Especially, when the product is operated in severe environment and operating conditions such as the coast, take measures early.
- (5) The interval of 3 years is recommended to change diaphragm, "O" ring and spring.
- (6) Refer to the spare parts list as for parts for replacement.
- (7) Assembling / disassembling of the product should be performed indoors in accordance with the assembling / disassembling drawing.
- (8) 1~2 times of operation test is necessary if the product is not operated for a long period

8. Example Application

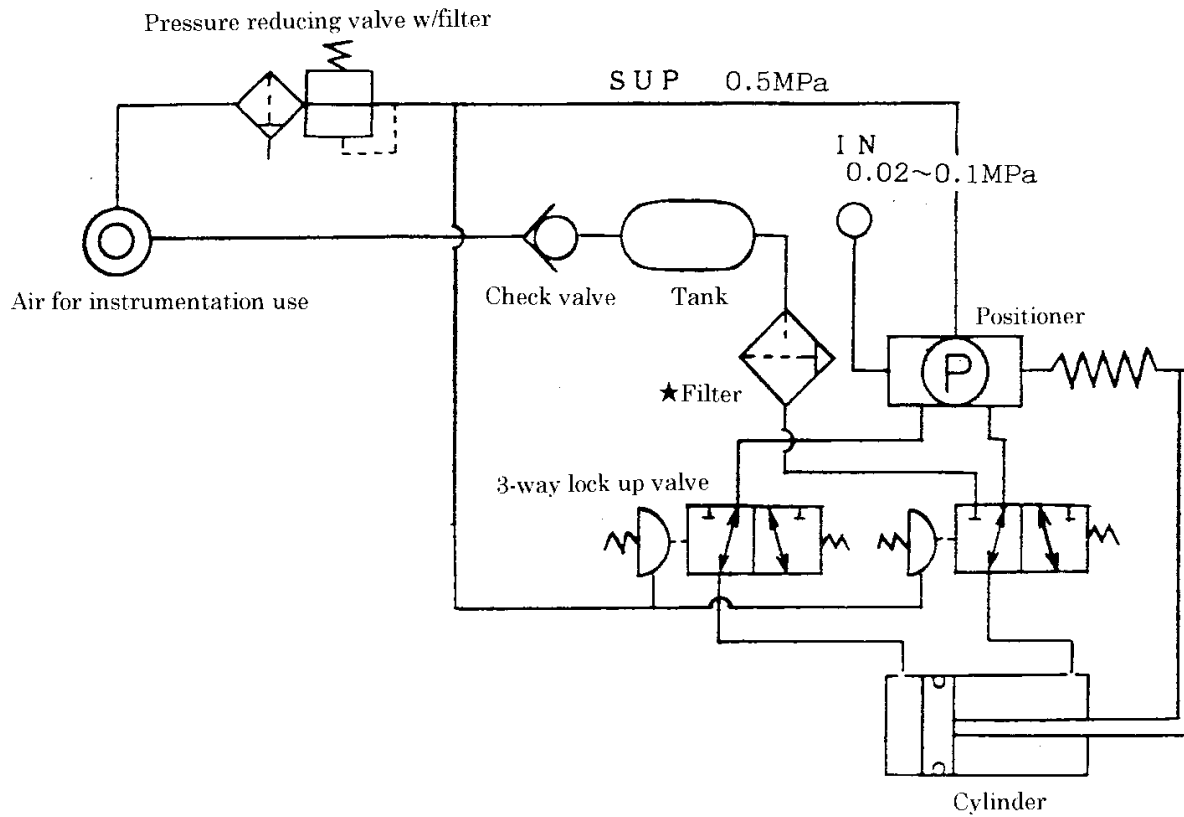

★ A filter is used to remove dust in air.

Note : Above diaphragm shows the situation when the supply pressure is higher than the setting pressure.

9. Troubleshooting



Warning

Stop using the product if failures are not improved.

Failures	Causes	Countermeasures
Excess flow from exhaust port	Dust and carbon adhere to seating part of exhaust port of diaphragm Ass'y.	Disassembling cleaning (Change diaphragm Ass'y if there is a flaw on seating part of exhaust port.)
	Breakage of diaphragm Ass'y.	Replace diaphragm Ass'y.
Air is not exhausted from exhaust port	Exhaust port of diaphragm Ass'y is closed.	Disassembling cleaning (Change diaphragm Ass'y if there is a flaw.)
Reducing the set pressure less than the signal pressure, doesn't switch the air circuit.	Exhaust port of diaphragm Ass'y is closed.	Disassembling cleaning (Change diaphragm Ass'y if there is a flaw.)
Raising the set pressure higher than the signal pressure doesn't switch the air circuit.	Filter for signal pressure is clogged up.	Replace filter.
	Diaphragm Ass'y is broken.	Change diaphragm Ass'y.
IN1 and IN2 allow air simultaneously.	Dust or carbon is adhered to rubber sheet of valve.	Disassembling cleaning (Change rubber sheet of valve if there is a flaw.)

Revision	
A	Format change and content review
B	Drawings update
C	Safety Instructions update
	Delete Drawing

SMC Corporation

Tel: + 81 3 5207 8249 Fax: +81 3 5298 5362
URL <https://www.smcworld.com>

Note: Specifications are subject to change without prior notice and any obligation on the part of the manufacturer.
© SMC Corporation All Rights Reserved

