



Operation Manual

PRODUCT NAME

BOOSTER RELAY

MODEL/ Series

IL100

SMC Corporation

Table of Contents

Instructions for your Safety	2~3
1. Outline	4
2. Specification	4
3. Structure and the Operation Principle	4~5
4. Transportation and Storage	6
5. Precautions in Using	7
6. Maintenance	8~9
7. Countermeasures for Failure	10
8. Drawings	11



Safety Instructions

These safety instructions are intended to prevent hazardous situations and/or equipment damage. These instructions indicate the level of potential hazard with the labels of “**Caution**,” “**Warning**” or “**Danger**.” They are all important notes for safety and must be followed in addition to International Standards (ISO/IEC)^{*1)}, and other safety regulations.

*1) ISO 4414: Pneumatic fluid power - General rules and safety requirements for systems and their components
 ISO 4413: Hydraulic fluid power - General rules and safety requirements for systems and their components
 IEC 60204-1: Safety of machinery - Electrical equipment of machines - Part 1: General requirements
 ISO 10218-1: Robots and robotic devices - Safety requirements for industrial robots - Part 1: Robots
 etc.



Danger

Danger indicates a hazard with a high level of risk which, if not avoided, will result in death or serious injury.



Warning

Warning indicates a hazard with a medium level of risk which, if not avoided, could result in death or serious injury.



Caution

Caution indicates a hazard with a low level of risk which, if not avoided, could result in minor or moderate injury.



Warning

1. The compatibility of the product is the responsibility of the person who designs the equipment or decides its specifications.

Since the product specified here is used under various operating conditions, its compatibility with specific equipment must be decided by the person who designs the equipment or decides its specifications based on necessary analysis and test results. The expected performance and safety assurance of the equipment will be the responsibility of the person who has determined its compatibility with the product. This person should also continuously review all specifications of the product referring to its latest catalog information, with a view to giving due consideration to any possibility of equipment failure when configuring the equipment.

2. Only personnel with appropriate training should operate machinery and equipment.

The product specified here may become unsafe if handled incorrectly. The assembly, operation and maintenance of machines or equipment including our products must be performed by an operator who is appropriately trained and experienced.

3. Do not service or attempt to remove product and machinery/equipment until safety is confirmed.

1. The inspection and maintenance of machinery/equipment should only be performed after measures to prevent falling or runaway of the driven objects have been confirmed.
2. When the product is to be removed, confirm that the safety measures as mentioned above are implemented and the power from any appropriate source is cut, and read and understand the specific product precautions of all relevant products carefully.
3. Before machinery/equipment is restarted, take measures to prevent unexpected operation and malfunction.

4. Our products cannot be used beyond their specifications. Our products are not developed, designed, and manufactured to be used under the following conditions or environments. Use under such conditions or environments is not covered.

1. Conditions and environments outside of the given specifications, or use outdoors or in a place exposed to direct sunlight.
2. Use for nuclear power, railways, aviation, space equipment, ships, vehicles, military application, equipment affecting human life, body, and property, fuel equipment, entertainment equipment, emergency shut-off circuits, press clutches, brake circuits, safety equipment, etc., and use for applications that do not conform to standard specifications such as catalogs and operation manuals.
3. Use for interlock circuits, except for use with double interlock such as installing a mechanical protection function in case of failure. Please periodically inspect the product to confirm that the product is operating properly.



Safety Instructions

Caution

We develop, design, and manufacture our products to be used for automatic control equipment, and provide them for peaceful use in manufacturing industries.

Use in non-manufacturing industries is not covered.

Products we manufacture and sell cannot be used for the purpose of transactions or certification specified in the Measurement Act.

The new Measurement Act prohibits use of any unit other than SI units in Japan.

Limited warranty and Disclaimer/Compliance Requirements

The product used is subject to the following “Limited warranty and Disclaimer” and “Compliance Requirements”.

Read and accept them before using the product.

Limited warranty and Disclaimer

1. The warranty period of the product is 1 year in service or 1.5 years after the product is delivered, whichever is first.*2)

Also, the product may have specified durability, running distance or replacement parts. Please consult your nearest sales branch.

2. For any failure or damage reported within the warranty period which is clearly our responsibility, a replacement product or necessary parts will be provided.

This limited warranty applies only to our product independently, and not to any other damage incurred due to the failure of the product.

3. Prior to using SMC products, please read and understand the warranty terms and disclaimers noted in the specified catalog for the particular products.

***2) Vacuum pads are excluded from this 1 year warranty.**

A vacuum pad is a consumable part, so it is warranted for a year after it is delivered.

Also, even within the warranty period, the wear of a product due to the use of the vacuum pad or failure due to the deterioration of rubber material are not covered by the limited warranty

Compliance Requirements

1. The use of SMC products with production equipment for the manufacture of weapons of mass destruction (WMD) or any other weapon is strictly prohibited.

2. The exports of SMC products or technology from one country to another are governed by the relevant security laws and regulations of the countries involved in the transaction. Prior to the shipment of a SMC product to another country, assure that all local rules governing that export are known and followed.

1. Outline

Increase the operating speed of controlling part when the piping between the instruments and the controlling part is very long, or the controlling part capacity is large.

2. Specification

Supply pressure	MAX.1.0MPa
Input · Output pressure	MAX.0.7MPa
Output flow	More than 600l/min(ANR)(SUP.0.5MPa)
Air consumption	Less than 3l/min(ANR) (OUT.0.5MPa)
Linearity	Within $\pm 1\%$
Hysteresis	Within 1%
Ambient temperature and operating fluid temperature	$-5^{\circ}\text{C}\sim 60^{\circ}\text{C}$
Port size	Rc1/4 · Rc3/8
Mass	560g

3. Structure and the operation principle

Input force from the instrument enters to the input chamber and act to diaphragm A. This works against the force generated by diaphragm B. When the force generated by the input is strong, the internal valve is pressed down and the supply air flows to the output side. When not strong, the internal valve is closed and the exhaust port opens for exhaust. This is how the force generated by diaphragm A and B is balanced. Opening of the throttle valve connect the air path of the input and the output. The adjustment of the throttle valve, the stability of the closed loop including the booster relay is improved.

MODEL IL100 BOOSTER RELAY

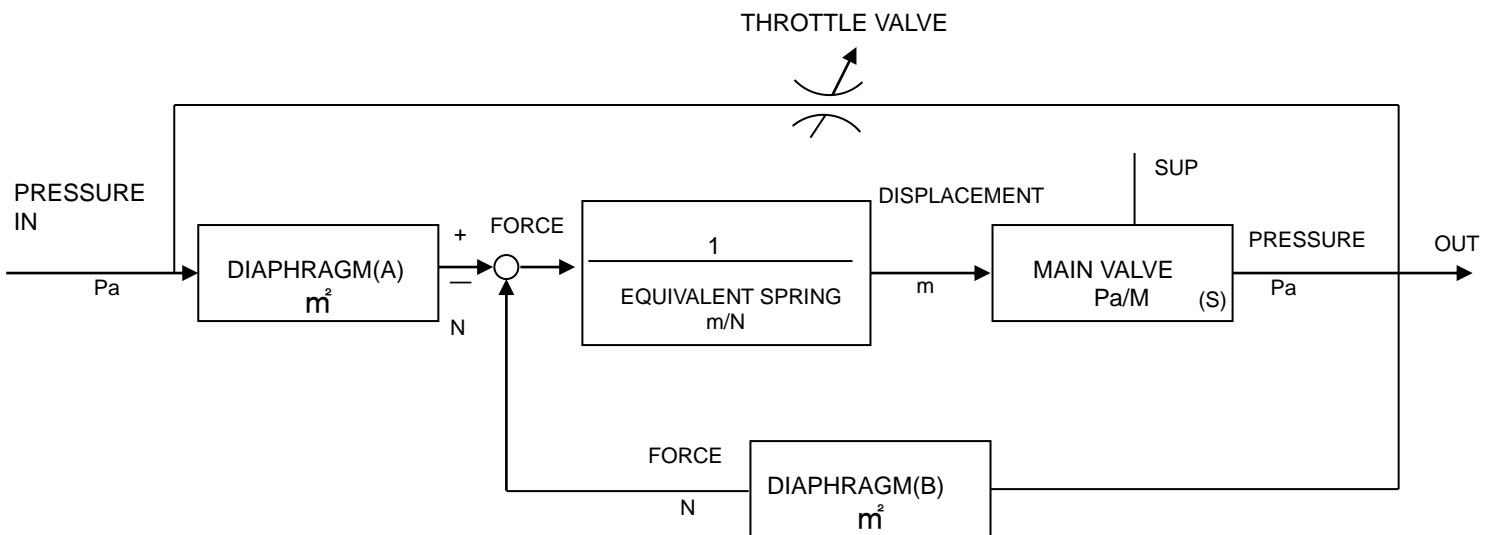
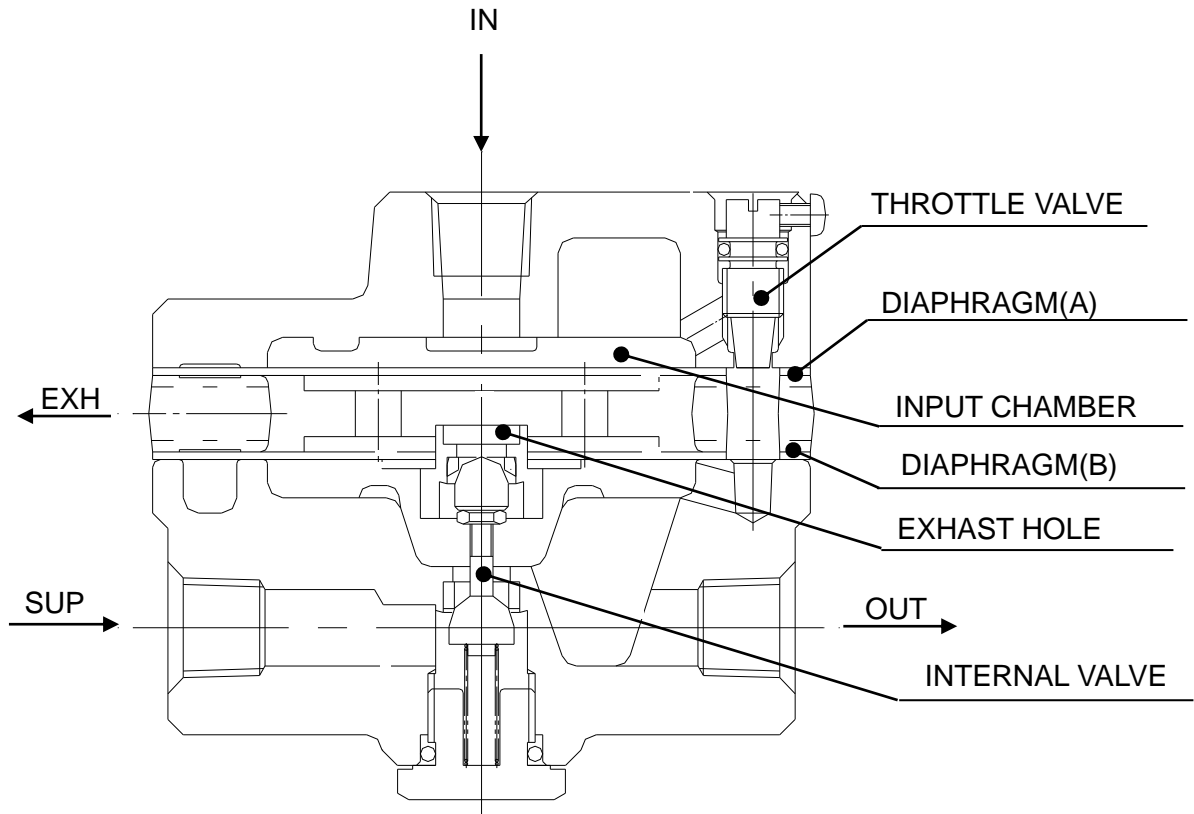

MODEL IL100 BLOCK DIAGRAM

4. Transportation and Storage



Warning

- (1) Handle the product with care.
- (2) Do not expose to rain.
- (3) The product is packed in a vinyl bag for shipment to prevent from dust. Avoid taking out of the bag just before piping even after unpacking.
- (4) If the product is kept unpacking for a certain period, select a place where there is no moisture nor corrosive gas.
While the product shipped has been applied specified paint and surface treatment, take care that inappropriate storing environment may cause generating rust.

5. Precautions in using



Warning

Operation

- (1) Do not operate the booster relay out of the specifications, because it causes malfunction.
- (2) If booster relay failure affecting the system is expected, provide a safety circuit for the system to avoid danger.



Warning

Handling

- (1) Excess vibration and impact on the booster relay cause failure, may cause failure, so that take care in handling during transportation and operation.
- (2) Mount the filter to the pressure supply line. Use the mist separator when the oil mist and carbon are contained.
- (3) Flush the air piping before connecting the booster relay.
- (4) Mind the arrow direction of the air flow when piping.
- (5) The trottle valve is opened for 3/4 turn and locked. No adjustment is necessary except when the control system is unstable.
- (6) Opening the trottle valve delays the response, closing quickens the response.



Warning

Air supply

- (1) Please use the filter to the supply line. Where contained oil mist and carbon, please use the mist separator.
- (2) Avoid using compressed air compressed air containing chemicals, synthetic fluid including organic solvent, salinity, and corrosive gas as it may cause malfunction.



Warning

Environment

- (1) Do not use in environment where the product is exposed to corrosive gas, chemicals, salt water, water or steam.
- (2) Do not operate the product in a location where it is subject to strong vibration and/or shock. For vibration, it should be within IG 60Hz.

6. Maintenance



Warning

- (1) To handle compressed air, person that has experienced and has knowledge about instrumentation machine is suitable. That kind of person should operate unit replacement and maintenance with keeping product specification.
- (2) To remove booster relay or to replace unit with product set, please exhaust residual pressure within piping with supply air stopped.
- (3) After mounting, maintenance and disassemble, please test leakage and function with compressed air supplied. When louder breed sound than initial, or when machine do not operate properly, please confirm correct mounting.



Caution

- (1) Periodical check (recommended : once / year)
Please check once per year on this product. To check, disassemble product following disassemble drawing, and check following item. When disassemble, pay attention in order not to damage diaphragm, in the case of diaphragm stick to body.

Part description	Check items	Confirmation	Countermeasure
Diaphragm (2,10)	No crack or flaw on the surface	Visual inspection	Part replacement if abnormality is found.
"O"ring (11,12)	No crack or flaw on the surface	Visual inspection	
Valve stem spring (6)	No crack due to hold	Visual inspection	
Main valve (3)	Without lock nut loosen	Hand or tool	If loosen, retighten.

*() shows booster relay disassemble drawing part no.

To re-assemble, ensure no foreign matter inside product and pay attention for air path position of each part.

- (2) Product replacement (recommended : once / 3 years)
This product rubber part is recommended to replace once per 3 years. Part replacement adjustment (valve seat centering, main valve length adjustment etc.) make effects on property. Product replacement is recommended by whole product per 3 years if it is used on extremely important point.



Warning

(Adjustment on Part replacement)

Diaphragm replacement and product disassemble & re-assemble may change in/output characteristics. For that circumstances, adjust main valve length. Main valve, as shown below, is adjusted the length by screw and fixed with lock nut. To adjust length, loose lock nut. For the main valve length adjustment, make longer when output is low to input signal. Make shorter when output is high to input signal. Main valve total length is basically 25 ± 1 mm.

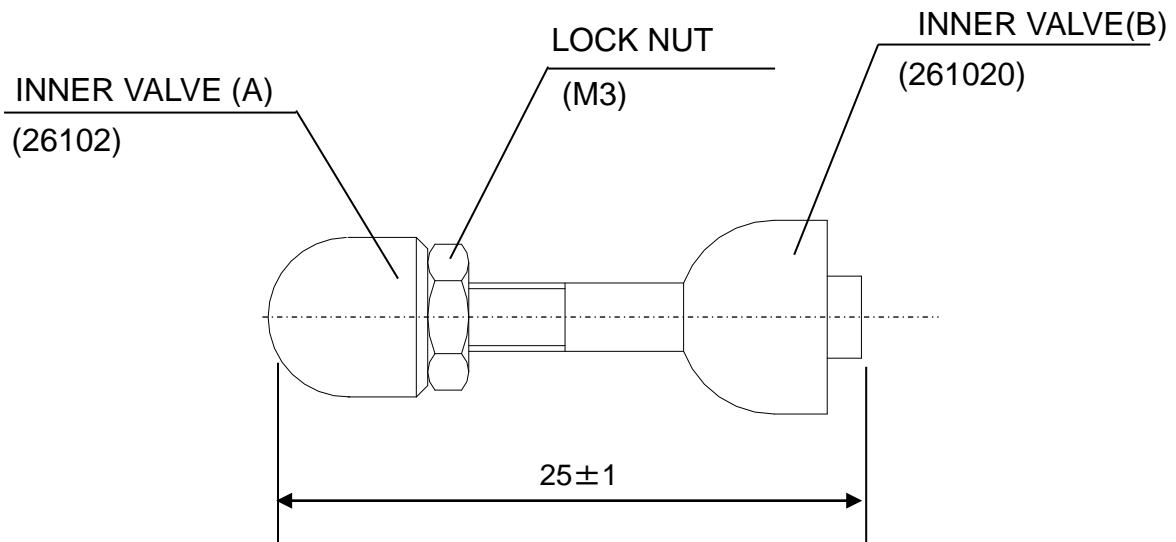

INNER VALVE Ass'y (26100-6)

7.Countermeasures for failure



Warning

Avoid use when failure is not solved.

Phenomenon	Cause	Countermeasures
Too much flow from exhaust port	Dust attach supply port or exhaust port	Disassemble and clean. (If flawed, replace the part.)
	Broken diaphragm	Replace diaphragm
No signal even if input signal is applied	Pressure leak due to loosen screw	Tighten screw
	Restrictor open too much	Decrease open degrees of restrictor, and lock.
	Broken diaphragm	Replace diaphragm
Bad characteristic	Valve stem length is changed due to loosen lock nut	Readjust into optimum valve, and lock.
	Plugged restrictor	Disassemble and clean
	Deformed diaphragm	Replace diaphragm

- | A | Safety instructions update |
|---|-----------------------------------------------------------------|
| B | Drawings update |
| C | Spare parts list, Drawings update |
| D | Safety instructions update
Delete Spare parts list, Drawings |

SMC Corporation

Tel: + 81 3 5207 8249 Fax: +81 3 5298 5362

URL <https://www.smcworld.com>

Note: Specifications are subject to change without prior notice and any obligation on the part of the manufacturer.
© SMC Corporation All Rights Reserved