



# Operation Manual

*Original Instructions*

PRODUCT NAME

*Thermo Chiller*

MODEL / SERIES / PRODUCT NUMBER

**HRZF010-WS**  
**HRZF010-W1S**

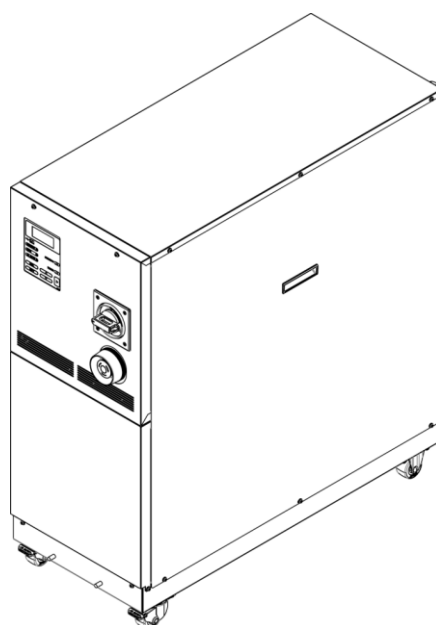

**SMC Corporation**

## To The Customers

Thank you for purchasing our Thermo Chiller HRZF Series (hereinafter called "This system").

For the long-term, safe use of this system, be sure to read and understand this manual thoroughly before performing operation of this system.

Warnings and precautions defined in this manual shall be observed.

This manual provides the explanations of the installation and operation of this system. Only those who have thorough understanding of the fundamental operating procedure or have basic knowledge and skills of handling industrial equipment for the installation and operation of this system are qualified to perform installation and operation.

The contents of this manual and related documents supplied with this system shall be neither regarded as a provision of the contract nor utilized to correct or modify the existing agreements, commitments and relations.

Copying, duplicating or transferring any part of or whole contents of this manual without the prior written consent of SMC Corporation is strictly prohibited.

The Service Manual is supplied in addition to this manual and provides the explanations of the inspection, troubleshooting, and in-depth remedies of this system. The Service Manual is intended for service personnel that completed service training SMC provides. Only those who fall under the above condition are allowed to perform maintenance and repair of this system with the use of the Service Manual.

Note: The contents of this manual are subject to change without notice.

## Table of Contents

<b>Chapter 1 Safety</b> .....	<b>1-1</b>
<b>1.1 Before Using This System</b> .....	<b>1-1</b>
<b>1.2 Compliance Requirements</b> .....	<b>1-1</b>
<b>1.3 Danger, Warning, and Caution Used in This Manual</b> .....	<b>1-4</b>
1.3.1 Hazard Levels .....	1-4
1.3.2 Definitions of “Serious Injury” and “Minor Injury” .....	1-4
1.3.3 Symbols.....	1-5
<b>1.4 Hazard Warning Label</b> .....	<b>1-7</b>
1.4.1 Type of Hazard Warning Label .....	1-7
1.4.2 Location of Hazard Warning Label .....	1-9
<b>1.5 Location of Model Label</b> .....	<b>1-12</b>
<b>1.6 Safety Measures</b> .....	<b>1-13</b>
1.6.1 Safety Precautions.....	1-13
1.6.2 Safety Interlock System .....	1-14
1.6.3 Lockout/Tagout.....	1-15
1.6.4 Protective Equipment.....	1-17
<b>1.7 Emergency Measures</b> .....	<b>1-18</b>
1.7.1 Emergency Off [EMO] Switch .....	1-18
<b>1.8 Waste Disposal</b> .....	<b>1-20</b>
1.8.1 Disposal of Refrigerant and Compressor Oil .....	1-20
1.8.2 Circulating Fluid Disposal .....	1-21
1.8.3 System Disposal.....	1-21
1.8.4 Label .....	1-21
<b>1.9 Safety Data Sheet (SDS)</b> .....	<b>1-22</b>
<b>Chapter 2 Name of Each Section</b> .....	<b>2-1</b>
<b>2.1 Name of Each Section</b> .....	<b>2-1</b>
<b>Chapter 3 Transporting and Installation</b> .....	<b>3-1</b>
<b>3.1 Transporting</b> .....	<b>3-1</b>
3.1.1 Transporting with Forklift.....	3-2
3.1.2 Transporting with Caster .....	3-3
<b>3.2 Installation</b> .....	<b>3-3</b>
3.2.1 Installation Conditions.....	3-4
3.2.2 Installation Location and Maintenance Work Area .....	3-5
<b>3.3 Procedure for Installation</b> .....	<b>3-6</b>
3.3.1 Installation .....	3-6
3.3.2 Procedure for System Securing.....	3-6
3.3.3 Wiring Installation .....	3-7
3.3.4 Procedures for Wiring Installation .....	3-9
3.3.5 Installation of Circulating Fluid and Facility Water Piping .....	3-12
3.3.6 Facility Water.....	3-15
<b>Chapter 4 System Startup and Shutdown</b> .....	<b>4-1</b>
<b>4.1 Pre-check</b> .....	<b>4-1</b>
4.1.1 Installation Condition .....	4-1
4.1.2 Cable Connection .....	4-1
4.1.3 Installation of Circulating Fluid and Facility Water Piping .....	4-1

---

4.1.4	Operating Signal from Your System .....	4-1
4.1.5	Check Emergency Off [EMO] Switch .....	4-1
<b>4.2</b>	<b>Opening of Facility Water Valve .....</b>	<b>4-1</b>
<b>4.3</b>	<b>Supply of Circulating Fluid.....</b>	<b>4-2</b>
4.3.1	Preparation of Circulating Fluid .....	4-2
4.3.2	Supply of Circulating Fluid .....	4-3
<b>4.4</b>	<b>Requirement for System Startup .....</b>	<b>4-4</b>
4.4.1	Turning ON Power .....	4-4
4.4.2	Circulating Fluid Temperature Setting .....	4-5
<b>4.5</b>	<b>System Startup and Shutdown .....</b>	<b>4-5</b>
4.5.1	System Startup .....	4-5
4.5.2	System Shutdown .....	4-5
<b>Chapter 5</b>	<b>System Operation.....</b>	<b>5-1</b>
<b>5.1</b>	<b>Operation Display Panel .....</b>	<b>5-1</b>
<b>5.2</b>	<b>Flow Chart of Operation Screen .....</b>	<b>5-2</b>
<b>5.3</b>	<b>Operation Screen .....</b>	<b>5-4</b>
5.3.1	Model Indication Screen .....	5-4
5.3.2	Status Screen 1 .....	5-5
5.3.3	Status Screen 2 .....	5-6
5.3.4	Status Screen 3 .....	5-7
5.3.5	Status Screen 4 .....	5-8
5.3.6	Alarm Display Screen .....	5-9
5.3.7	Menu Screen .....	5-9
5.3.8	Setting Screen .....	5-10
5.3.9	Control Setting Screen 1.....	5-11
5.3.10	Control Setting Screen 2.....	5-12
5.3.11	Control Setting Screen 3-1.....	5-13
5.3.12	Control Setting Screen 3-2.....	5-14
5.3.13	Alarm Setting Screen 1 .....	5-15
5.3.14	Alarm Setting Screen 2 .....	5-16
5.3.15	Alarm Setting Screen 3 .....	5-17
5.3.16	Initial Setting Screen 1.....	5-18
5.3.17	Initial Setting Screen 2.....	5-19
5.3.18	Initial Setting Screen 3.....	5-20
5.3.19	Initial Setting Screen 4.....	5-21
5.3.20	Initial Setting Screen 5.....	5-22
5.3.21	Initial Setting Screen 6.....	5-23
5.3.22	Initial Setting Screen 7.....	5-24
5.3.23	Initial Setting Screen 8.....	5-25
5.3.24	Mode Selection Screen .....	5-26
5.3.25	Maintenance Screen 1 .....	5-27
5.3.26	Maintenance Screen 2 .....	5-28
5.3.27	Maintenance Screen 3.....	5-29
5.3.28	Maintenance Screen 4 .....	5-30
5.3.29	Maintenance Screen 5.....	5-31
5.3.30	Maintenance Screen 6.....	5-32

---

5.3.31	Maintenance Screen 7 .....	5-33
5.3.32	Maintenance Screen 8 .....	5-34
5.3.33	System Information Screen.....	5-35
<b>5.4</b>	<b>Examples of System Operation .....</b>	<b>5-36</b>
5.4.1	Example 1: Circulating fluid set temperature is changed from 20.0 deg. C to 34.1 deg. C....	5-36
5.4.2	Example 2: Communication mode is switched from "LOCAL" to "SER REMOTE". .....	5-38
5.4.3	Example 3: PUMP IV is switched from "FLOW" to "FREQ".....	5-39
<b>Chapter 6</b>	<b>Error Message and Troubleshooting .....</b>	<b>6-1</b>
<b>6.1</b>	<b>Error Message .....</b>	<b>6-1</b>
<b>6.2</b>	<b>Troubleshooting.....</b>	<b>6-2</b>
<b>Chapter 7</b>	<b>System Maintenance .....</b>	<b>7-1</b>
<b>7.1</b>	<b>Water Quality Management .....</b>	<b>7-1</b>
<b>7.2</b>	<b>Inspection and Cleaning.....</b>	<b>7-2</b>
7.2.1	Daily Inspection .....	7-2
7.2.2	Quarterly Inspection .....	7-3
<b>7.3</b>	<b>Storage .....</b>	<b>7-3</b>
7.3.1	Draining of Circulating Fluid Out of Tank .....	7-4
7.3.2	Draining of Facility Water.....	7-5
<b>7.4</b>	<b>Periodic Replacement Parts.....</b>	<b>7-6</b>
<b>Chapter 8</b>	<b>Appendix .....</b>	<b>8-1</b>
<b>8.1</b>	<b>Specification.....</b>	<b>8-1</b>
8.1.1	System Specification .....	8-1
8.1.2	Cooling Capacity .....	8-3
8.1.3	Heating Capacity .....	8-4
8.1.4	Pump Performance Curve .....	8-5
8.1.5	Refrigerant with GWP Reference .....	8-6
8.1.6	Communication Specifications .....	8-7
8.1.7	Alarm Signal Selection .....	8-10
<b>8.2</b>	<b>Outer Dimensions .....</b>	<b>8-11</b>
<b>8.3</b>	<b>Flow Chart.....</b>	<b>8-12</b>
<b>8.4</b>	<b>Offset Function .....</b>	<b>8-13</b>
8.4.1	Example of Offset Function .....	8-14
<b>8.5</b>	<b>BAND/READY Function .....</b>	<b>8-16</b>
<b>8.6</b>	<b>Anchor Bolt Mounting Position .....</b>	<b>8-17</b>
<b>8.7</b>	<b>Compliance.....</b>	<b>8-18</b>
<b>8.8</b>	<b>Thermo Chiller Daily Inspection Sheet .....</b>	<b>8-19</b>
<b>Chapter 9</b>	<b>Product Warranty.....</b>	<b>9-1</b>
<b>9.1</b>	<b>Warranty .....</b>	<b>9-1</b>
<b>9.2</b>	<b>Warranty Period.....</b>	<b>9-1</b>
<b>9.3</b>	<b>Warranty Exemption .....</b>	<b>9-1</b>
<b>9.4</b>	<b>Escape Clause.....</b>	<b>9-1</b>
<b>9.5</b>	<b>Warranty Precondition .....</b>	<b>9-2</b>
<b>9.6</b>	<b>Request for Warranted Repair .....</b>	<b>9-2</b>



# Chapter 1 Safety



Be sure to read and understand the important precautions defined in this manual thoroughly prior to system use.

## 1.1 Before Using This System

- This "Safety" chapter describes the safety-related items that users should be aware of upon handling this system.
- This system, which is operated under high voltage, is outfitted with the parts that cause a rise or drop in temperature and rotating parts when it is in action. All personnel who work with or around this system are required to thoroughly read and understand the safety-related items in this manual prior to working with or around this system.
- This manual is not intended to be used as a manual for comprehensive safety and hygiene education. Such a manual should be provided by a safety training manager.
- The product is operated at high voltage and contains components which become hot and rotate. If a component needs to be replaced or repaired, contact a specialized vendor for parts and service.
- A safety manager is responsible for observing safety standards. Operators and maintainers, however, are to have individual responsibilities for complying with the safety standard in his/her daily work.
- Operators and maintainers must individually take account of safety and assure a proper working area and working environment.
- The relevant personnel must receive proper safety education prior to work training on this system. Otherwise, personnel may be exposed to hazards. Never conduct work training without giving proper consideration to safety.
- Do not use the materials that rust or corrode for the circulating fluid and facility water circuits. Using the materials that tend to rust or corrode may cause clogs or/and leakages of the circulating fluid and facility water circuits. In case of using these kind of materials, consider and carry out some prevention against the rusting or corrosion on the customer side.
- Save this manual at a designated place for reference when necessary.
- This appliance is not intended for use by persons (including children) with reduced physical, sensory or mental capabilities, or lack of experience and knowledge, unless they have been given supervision or instruction concerning use of the appliance by a person responsible for their safety.
- This product uses a flammable refrigerant. Do not use near fire.

## 1.2 Compliance Requirements

The use of SMC products with production equipment for the manufacture of weapons of mass destruction (WMD) or any other weapon is strictly prohibited. The exports of SMC products or technology from one country to another are governed by the relevant security laws and

regulations of the countries involved in the transaction. Prior to the shipment of a SMC product to another country, assure that all local rules governing that export are known and followed.

## **WARNING**



- 1. The compatibility of the product is the responsibility of the person who designs the equipment or decides its specifications. Since the product specified here is used under various operating conditions, its compatibility with specific equipment must be decided by the person who designs the equipment or decides its specifications based on necessary analysis and test results. The expected performance and safety assurance of the equipment will be the responsibility of the person who has determined its compatibility with the product. This person should also continuously review all specifications of the product referring to its latest catalog information, with a view to giving due consideration to any possibility of equipment failure when configuring the equipment.**
- 2. Only personnel with appropriate training should operate machinery and equipment. The product specified here may become unsafe if handled incorrectly. The assembly, operation and maintenance of machines or equipment including our products must be performed by an operator who is appropriately trained and experienced.**
- 3. Our products cannot be used beyond their specifications. Our products are not developed, designed, and manufactured to be used under the following conditions or environments. Use under such conditions or environments is not covered.**
  - A: Conditions and environments outside of the given specifications, or use outdoors or in a place exposed to direct sunlight.**
  - B: Use for nuclear power, railways, aviation, space equipment, ships, vehicles, military application, equipment affecting human life, body, and property, fuel equipment, entertainment equipment, emergency shut-off circuits, press clutches, brake circuits, safety equipment, etc., and use for applications that do not conform to standard specifications such as catalogs and operation manuals.**
  - C: Use for interlock circuits, except for use with double interlock such as installing a mechanical protection function in case of failure. Please periodically inspect the product to confirm that the product is operating properly.**



## CAUTION



We develop, design, and manufacture our products to be used for automatic control equipment, and provide them for peaceful use in manufacturing business.

Use in non-manufacturing business is not covered.

Products we manufacture and sell cannot be used for the purpose of transactions or certification specified in the Measurement Act.

The new Measurement Act prohibits use of any unit other than SI units in Japan.

## 1.3 Danger, Warning, and Caution Used in This Manual

### 1.3.1 Hazard Levels

This system is designed with its first priority being the safety of workers and the prevention of system damage. This manual classifies the risks into the following three categories according to the severity and level of the hazard, Danger, Warning, and Caution. Read the statements carefully, thoroughly understand them before operating this system. They are all important notes for safety and must be followed in addition to International Standards (ISO/IEC), and other safety regulations.

DANGER, WARNING and CAUTION signs are in order according to hazard severity (DANGER > WARNING > CAUTION). See below for the details.

#### **DANGER**

"DANGER" denotes that there is an imminent hazard which will cause serious personal injury or death during operation.

#### **WARNING**

"WARNING" denotes that there is a hazard which may cause serious personal injury or death during operation.

#### **CAUTION**

"CAUTION" denotes that there is a hazard which may cause minor personal injury during operation.

#### **CAUTION**

"CAUTION" without an exclamation symbol denotes that there is a hazard which may cause damage or failure of this system, facility, or devices.

#### [Tips]

Tips are provided when there is information personnel are required to be aware of for system operation and maintenance. If the task carries useful information, the relevant tips are given as well.

### 1.3.2 Definitions of "Serious Injury" and "Minor Injury"

#### ■ "Serious Injury"

This term describes injuries such as loss of eyesight, wound, burns, frostbite, electric shock, fracture, and toxication that leave aftereffects, and/or injury requiring hospitalization and/or prolonged staying in a hospital.

#### ■ "Minor Injury"

This term describes injuries that do not require hospitalization or prolonged staying in a hospital (injuries other than "serious injuries" described above).

### 1.3.3 Symbols

This manual provides the following symbols in addition to “Danger”, “Warning”, and “Caution” to present the warning details in easy-to-understand manner.

#### ■ Symbol of Electrical Hazard

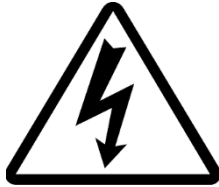

This symbol warns you of potential electrical shock.

#### Symbol of Heat Hazard



This symbol warns you of potential burns.

#### ■ Symbol of Low Temperature Hazard



This symbol warns you of potential frostbite.

#### ■ Symbol of “Don’ts”



This symbol denotes “Don’t” item which you must not do in operation of this system.

#### ■ Symbol of “Required Action”



This symbol denotes the “obligation” items which you must follow in operation of this system.

■ Symbol of Fire Hazard

This symbol warns you of fire hazards.



The image displays three fire hazard symbols arranged vertically. The top symbol is a yellow triangle with a black border and a black flame icon. The middle symbol is a red triangle with a white border and a white flame icon. The bottom symbol is a white diamond with a red border and a black flame icon.

## 1.4 Hazard Warning Label

The hazard warning labels are applied to the sections of this system where potential hazards are present during system operation and maintenance.

The hazard warning labels are in appropriate sizes and colors to get attention of the operator. They contain symbols in addition to the descriptions of warnings.

### 1.4.1 Type of Hazard Warning Label

The hazard warning labels affixed on this system are listed below.

#### ■ Labels of High Voltage Hazard

##### [High Voltage Hazard]

This warning label is affixed on the part isolated with the cover panel of the system panel in which high voltage is applied. Do not remove cover panels that are not designated in this manual.



Fig.1-1 Hazard Warning Label No.1

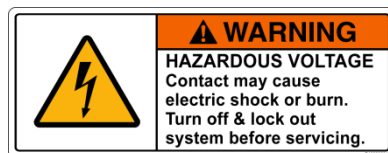

Fig.1-2 Hazard Warning Label No.2

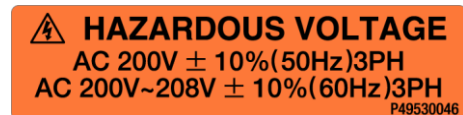

Fig.1-3 Hazard Warning Label No.3

#### ■ Labels of Hot/Cold Surface Hazard

##### [Hot/Cold Surface Hazard]

This warning label is affixed on the surface that is at high or low temperatures carrying potential burns (or frostbite) if touched. Residual heat may cause burns despite the power being turned OFF. Be sure of the surface reaching room temperature before work.



Fig.1-4 Hazard Warning Label No.4

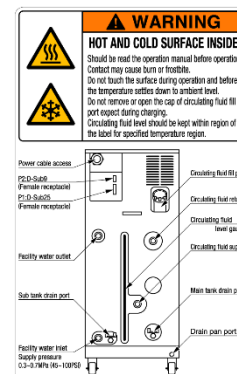

Fig.1-5 Hazard Warning Label No.5

■ Labels of Fire Hazard

**[Fire Hazard]**

This product uses a flammable refrigerant (R454C). Follow the contents of this fire warning label and safety precautions and handling instructions.



Fig.1-6 Hazard Warning Label No.6



Fig.1-7 Hazard Warning Label No.7



Fig.1-8 Hazard Warning Label No.8



Fig.1-9 Hazard Warning Label No.9

## 1.4.2 Location of Hazard Warning Label

### **WARNING**



Do not peel off or deface the hazard warning labels.

### **WARNING**



Confirm the locations of the hazard warning labels.

Read the contents of the hazard warning labels carefully and keep them in mind.

Users are **NOT** allowed to change the locations of the hazard warning labels. Make sure to affix a new label to exactly the same location of the replaced label upon replacement of the peeled off or worn out label.

### ■ High Voltage Hazard

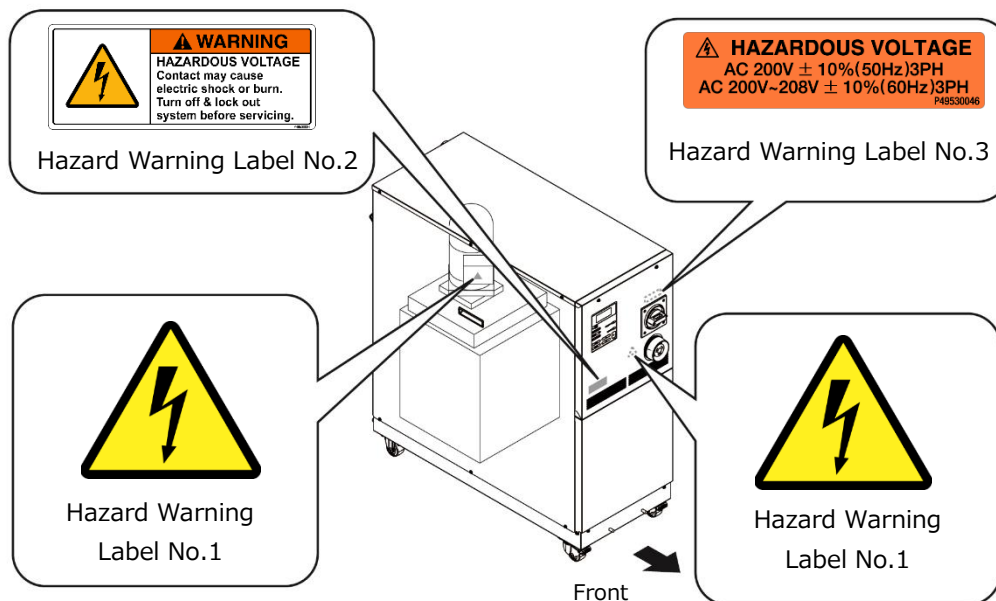

Fig.1-10 High Voltage Hazard

■ Hot/Cold Surface Hazard

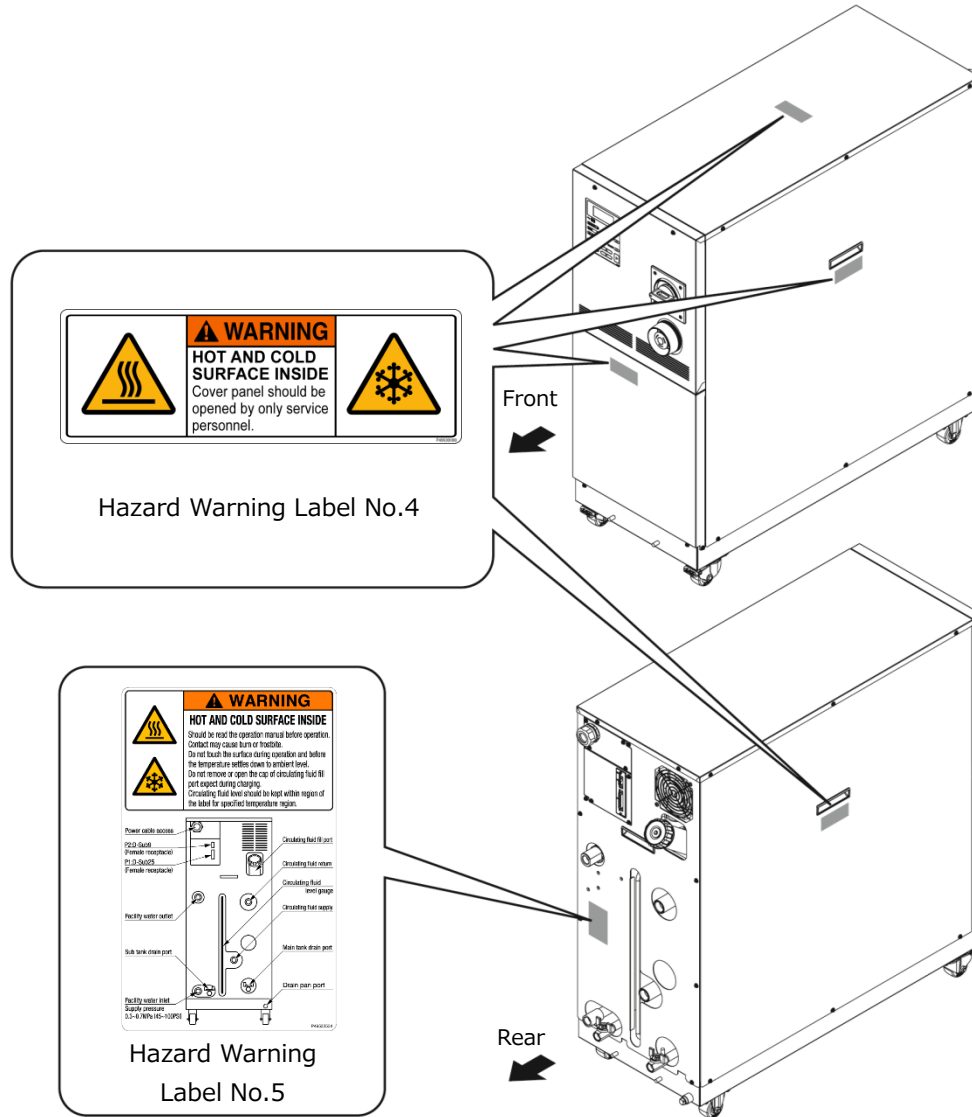

Fig.1-11 Hot/Cold Surface Hazard



■ Labels of Fire Hazard

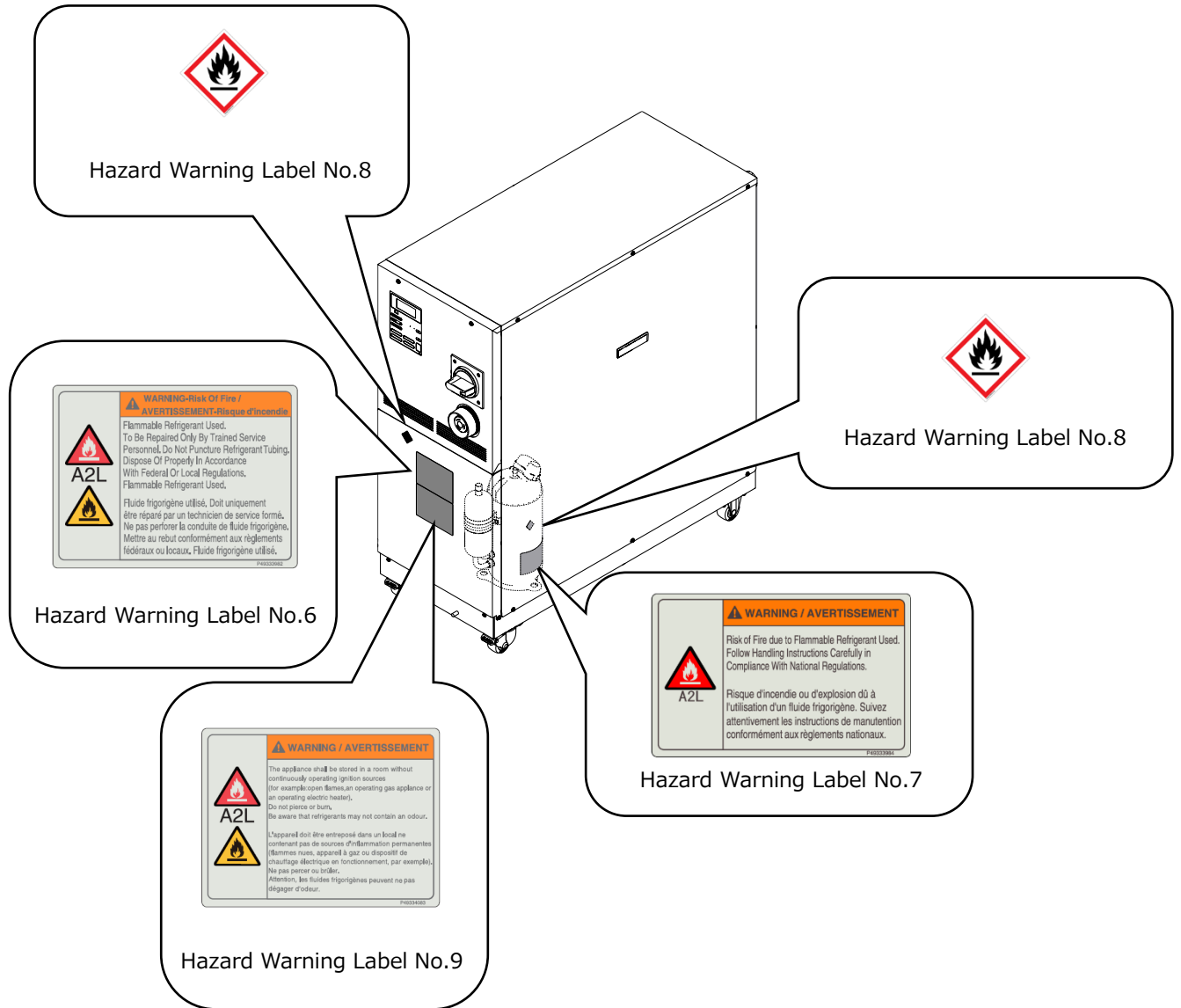

Fig.1-12 Labels of Fire Hazard

## 1.5 Location of Model Label

Information about the product, such as Serial No. and Model No. can be found on the product label. This information is needed when contacting an SMC sales distributor.

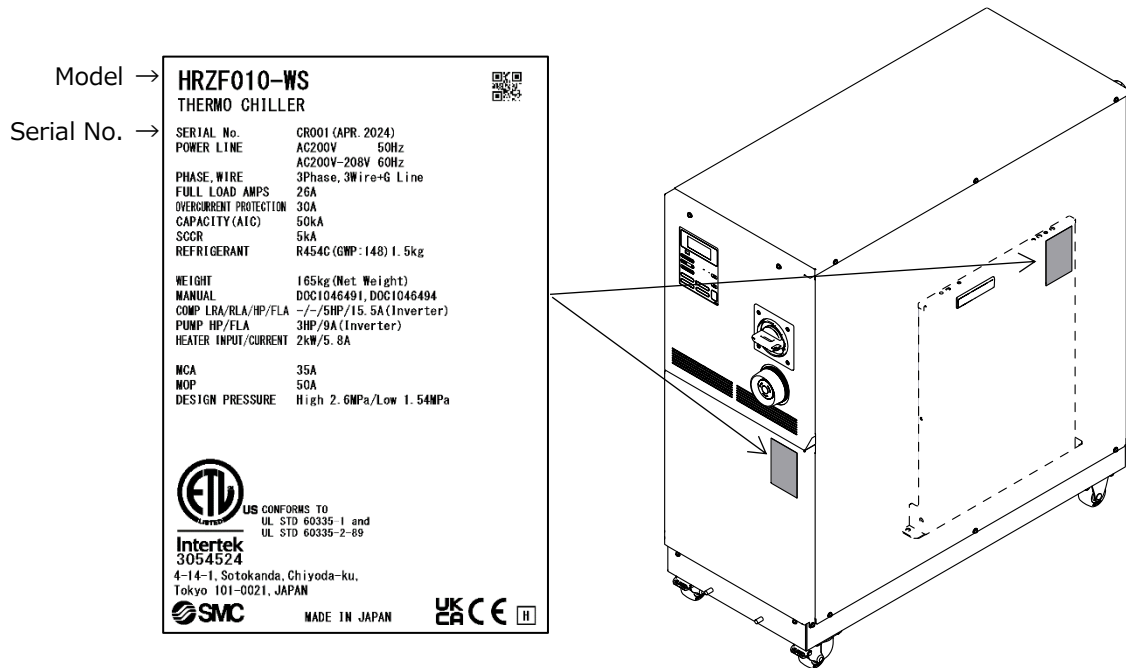

Fig.1-13 Location of Model Label

## 1.6 Safety Measures

### 1.6.1 Safety Precautions

While this system is protected by various safety measures including the safety interlocks, the following basic safety precautions should be observed to assure further safe operations.

#### **WARNING**



**Follow the following instructions upon operation of this system.  
Failure to follow the instructions can lead to personal injury or hazardous accidents.**

#### **WARNING**



**Flammable refrigerant (R454C) is used. Refer to the Repair Manual/Owner's Guide before servicing this product. Follow all safety precautions.**

**Do not use mechanical devices or other means to accelerate the defrosting process other than those recommended by the manufacturer.**

**Do not handle this product by any means other than specified in this Operation Manual; this can result in damage to the product or fire.**

**This product uses a slightly flammable refrigerant. In case of refrigerant leak, provide sufficient ventilation. Also, please keep away from fire.**

**The appliance shall be stored in a room without continuously operating ignition sources (for example: open flames, an operating gas appliance or an operating electric heater).**

**Do not pierce or burn.**

**Be aware that refrigerants may not contain an odour.**

- Read and understand this manual thoroughly before operation of this system.
- Before operating the system during maintenance, inform all personnel who are working in the vicinity of the system to alert them of your action.
- Use appropriate tools and follow proper procedures.
- See "1.6.4 Protective Equipment" on page 1-17 to wear protective equipment properly.
- Refer to your safety manual for emergency evacuation.
- Use assistance to carry object over 20 kg.
- Check that all parts and screws are returned to the pre-work conditions at the end of work.
- Do not work when intoxicated or feeling ill. Accidents may occur if disregarded.
- Do not remove a panel unless permitted in this manual.
- Do not handle this product by any means other than specified in this Operation Manual.
- The component parts shall be replaced with like components so as to minimize the risk of possible ignition due to incorrect parts.

## 1.6.2 Safety Interlock System

### ■ Safety Interlock System

The function of the safety interlock system is not only protecting personnel by restricting operation that may cause damage to this system or the facility around it but also eliminate the danger relating to safety. This system is outfitted with several interlock functions that are activated when improper operation or hazardous conditions occur. System operation shall be terminated when a safety interlock is activated.

An alarm message is displayed on the LCD screen when a safety interlock is activated. See "Chapter 6 Error Message and Troubleshooting" on page 6-1 for details on the alarms and remedies or see section "Troubleshooting" in a separate volume of the "Service Manual".

### ■ Front Panel

System repair may require the removal of the front panel.

The breaker handle operation is available only with the front panel attached.

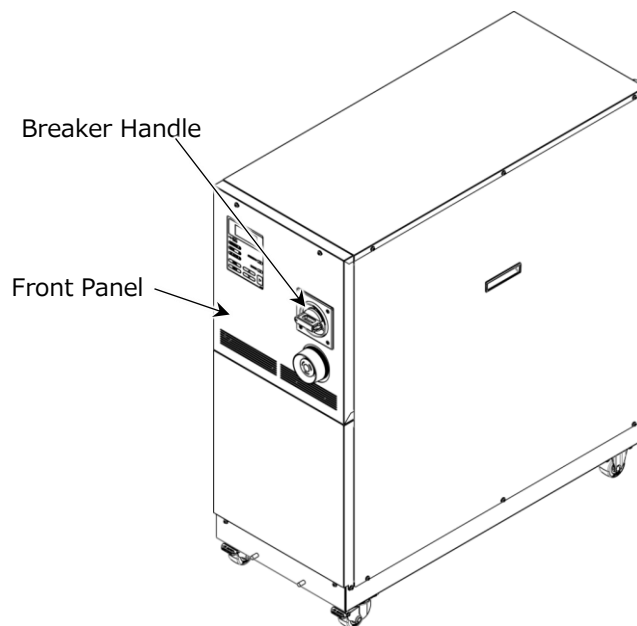

Fig.1-14 Front Panel

### 1.6.3 Lockout/Tagout

#### ■ Summary

Lockout in this system disables the main breaker operation to prevent electric shocks.

Tagout, to be placed on a locked out main breaker, to prevent improper breaker operation (ON) conducted by other personnel.

See Lockout procedure in the following pages for practical lockout/tagout.

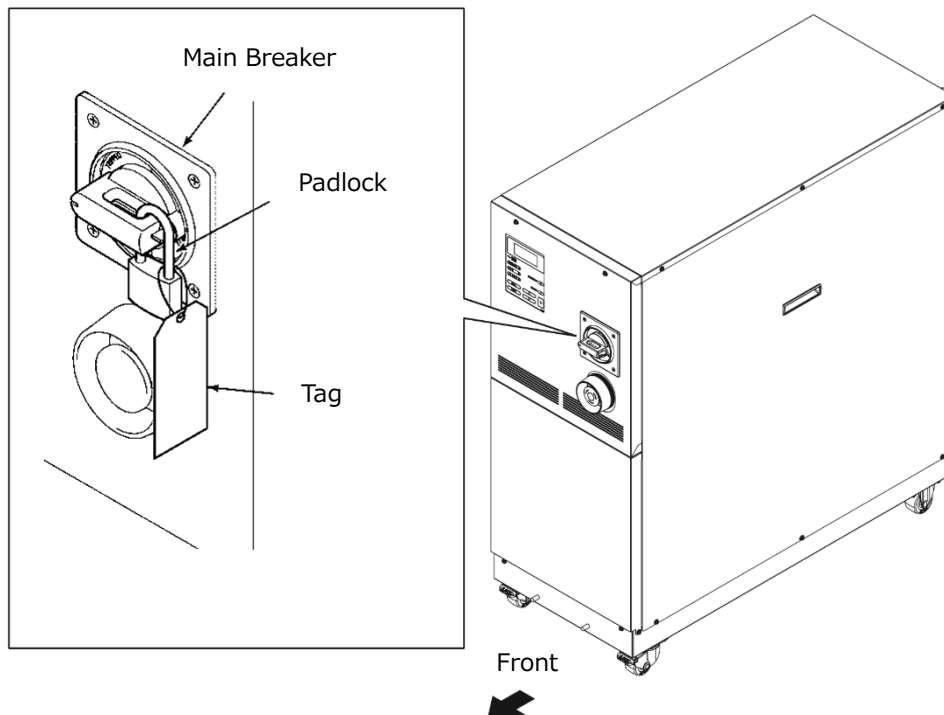

Fig.1-15 Lockout/Tagout

#### **⚠ WARNING**



Those who engage in service of this system should build an awareness of the importance of lockout. Thorough understanding of the procedures defined in this manual are required for system service.

Lockout is allowed only when the system come to a full stop.

A supervisor should be appointed to direct all personnel if multiple workers engage in system service.

The supervisor is to perform lockout based on a full understanding of overall process conditions.

Not only all personnel but new personnel that engage in service of this system should build an awareness of the importance of lockout and obtain thorough understanding of the lockout procedure.

Any personnel working in an area with high voltage should be assigned with padlocks and tags. The key for the padlock is kept under the responsibility of the supervisor, and lockout release is performed upon completion of work.

**⚠ WARNING**



All service personnel must observe the restrictions applied during lockout and are required to perform lockout in accordance with this procedure. No service personnel is allowed to start, energize, or use the locked out system.

- 1 Turn the breaker handle to 'OFF O'

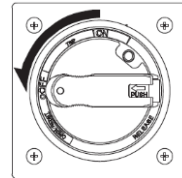

Fig.1-16 Breaker Handle at "OFF O"

- 2 Push the end face of the breaker handle and pull out the lock attachment.  
Hold the breaker handle with hand.  
The handle turns back to 'OFF O' if released.

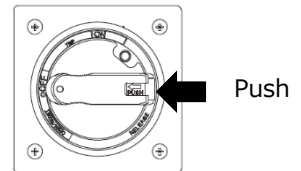

Fig.1-17 Breaker Handle

- 3 Lock the lock mechanism part with the padlock.

The lock mounting does not close.

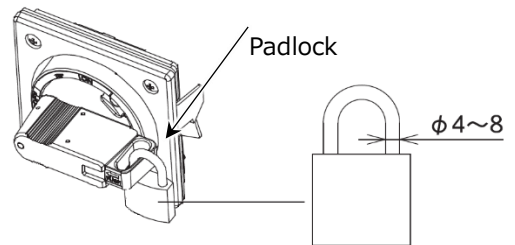

Fig.1-18 Breaker Lock

■ Releasing Lockout

- 1 Remove the padlock from the lock mechanism part.

- 2 Push the end face of the breaker handle and return the lock mounting.

The lock mounting part closes.

## 1.6.4 Protective Equipment

This manual defines protective equipment according to work type.

Wear proper protective equipment as shown below, according to work type.

### **WARNING**



Read and understand the relevant operation manual thoroughly prior to use of protective equipment.

#### ■ For system transportation, installation and removal

- Protective footwear
- Protective gloves
- Hard hat

#### ■ For handling circulating fluid

- Protective footwear
- Protective gloves
- Protective mask
- Protective apron
- Protective goggles

#### ■ For system operation

- Protective footwear
- Protective gloves

## 1.7 Emergency Measures

### 1.7.1 Emergency Off [EMO] Switch

Press the red emergency off [EMO] switch on the front of the system only if the need to shut off the power arises due to emergency such as natural disaster, fire, earthquake or personal injury.

The emergency off [EMO] switch is a large, red mushroom-shaped push button labeled with 'EMO' on it. The system comes to a halt if this button is pressed.

When press the emergency off [EMO] switch, the control power for this system is shut off to bring the system to a stop. The main breaker of this system, however, is designed not to trip, which enables the motor circuit to remain partially energized. "8.1.6 Communication Specifications" on page 8-7 to view the circuit diagram and see how the EMO switch is interconnected to the system.

Restart of this system is enabled only when this button is reset manually.

#### ■ Location of Emergency Off [EMO] Switch

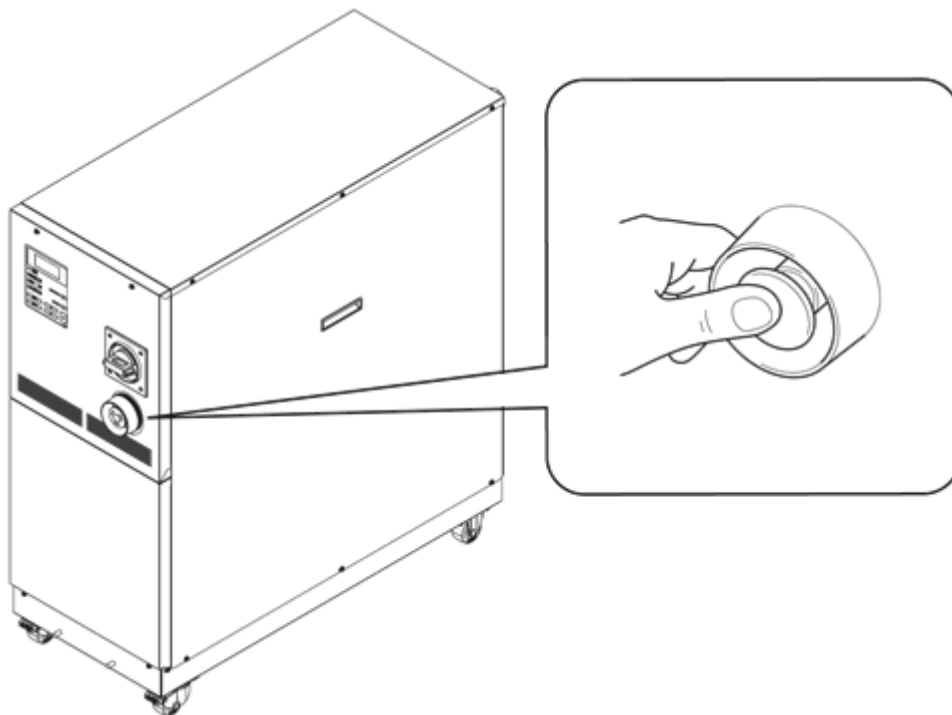

Fig.1-19 Location of Emergency Off [EMO] Switch



■ Reset of Emergency Off [EMO] Switch

**⚠ WARNING**



No automatic recovery is applied to the emergency off [EMO] switch. Always eliminate the cause of activating the EMO before resetting. Potential serious accidents may occur if disregarded.

- 1 Before restarting, always make sure that the cause of the emergency off condition (The reason why the EMO switch was activated) has been eliminated from the power supplies, the system and peripheral equipment.

- 2 With the cause completely eliminated, turn the emergency off [EMO] switch clockwise to reset. The EMO button returns to its original position.

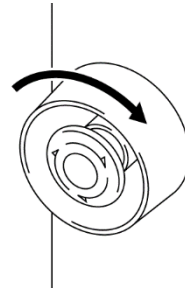

Fig.1-20 Reset of EMO Button

**⚠ WARNING**



When the system is in remote mode, the remote mode is retained despite the power outage. Thus the system operation is to resume as the start signal is issued from your system.

- 3 The screen then changes from the “Model Indication screen” to “Status screen 1” as power is being restored to the system.

## 1.8 Waste Disposal

### 1.8.1 Disposal of Refrigerant and Compressor Oil

This product contains flammable refrigerant and refrigeration oil. Please read and fully understand the following precautions before collecting the product. If you have any questions, please contact your dealer.

#### **WARNING**



Only service personnel or those who are qualified are allowed to open the panel of this system.

Do not dispose of the compressor oil as domestic garbage.

Incineration is permitted only at an authorized incinerator.

#### **WARNING**



Disposal of the compressor oil must be in accordance with regulations and rules of local authorities.

The release of refrigerant into the air is prohibited by law.

Recover the refrigerant with the "refrigerant recovery system", and request the specialized waste disposal agency for disposal of the recovered refrigerant.



Only personnel with proper licensing, who have adequate knowledge and experiences with not only this system but associated equipment are

allowed to implement the recovery of the refrigerant and compressor oil.

Dispose of refrigerant properly according to the laws or regulations of your country.



The use of flammable refrigerants poses a fire hazard.

#### **[Tips]**

---

For the type and quantity of the refrigerant, See "1.5 Location of Model Label" on page 1-12.

---

## 1.8.2 Circulating Fluid Disposal

As to the disposal of a circulating fluid (Ethylene glycol aqueous solution, Fluorinated fluid), consign the specialized industrial waste disposal agency with the contents detailed.

## 1.8.3 System Disposal

As to the disposal of this system, consign the specialized industrial waste disposal agency in accordance with local laws and regulations.

## 1.8.4 Label

Label described below which is attached to the top panel of product is that required by Japanese law, and the content of this label is applicable in Japan only.

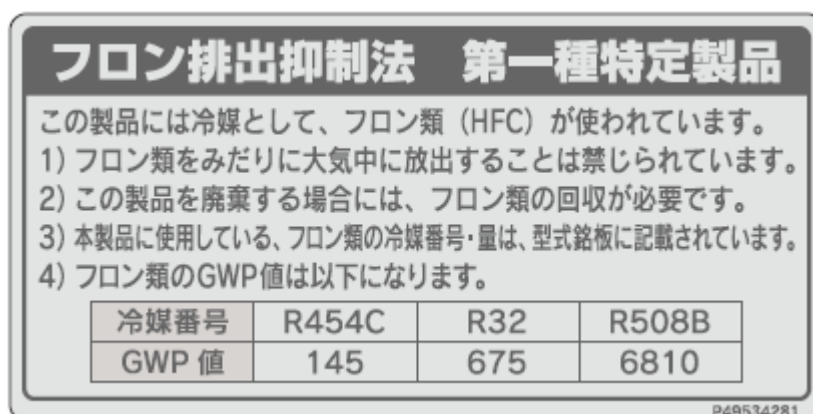

Contents of description of this label is shown as follows.

Fluorocarbon Collection and Destruction Law in Japan

This product uses Fluorocarbon (HFC) as a refrigerant.

1. It is strictly forbidden to emit Fluorocarbon to the atmosphere.
2. When disposing this product, Fluorocarbon must be collected in an appropriate manner.
3. This kind of Fluorocarbon and the amount used in this product is printed on the name label.
4. GWP values for Fluorocarbon are shown in the table below.

## 1.9 Safety Data Sheet (SDS)

For chemical substances purchased by the customer, please prepare the SDS by yourself. Please download the latest version of SDS from each company's website.

■ **Galden® HT 135 and Galden® HT 200**

Website : <https://www.solvay.com/en/>

■ **Fluorinert™ FC-3283 and Fluorinert™ FC-40**

Website : <https://www.3m.com/>

■ **60% Ethylene glycol aqueous solution**

Please contact our sales department.

■ **Opteon™ XL20 (R-454C) Refrigerant**

Website : <https://www.chemours.com/en>

SDS No. : 130000143547

### **WARNING**



Refrigerant recovery and refrigeration oil recovery operations should be performed by persons with sufficient knowledge and experience of the product and ancillary equipment and devices.

The cautionary clauses in the SDS are intended for normal handling, and sufficient safety, health, and environmental measures should be taken when special handling is performed.

Please note that items marked "not described" in the SDS have not been fully investigated at this time.

# Chapter 2 Name of Each Section

## 2.1 Name of Each Section

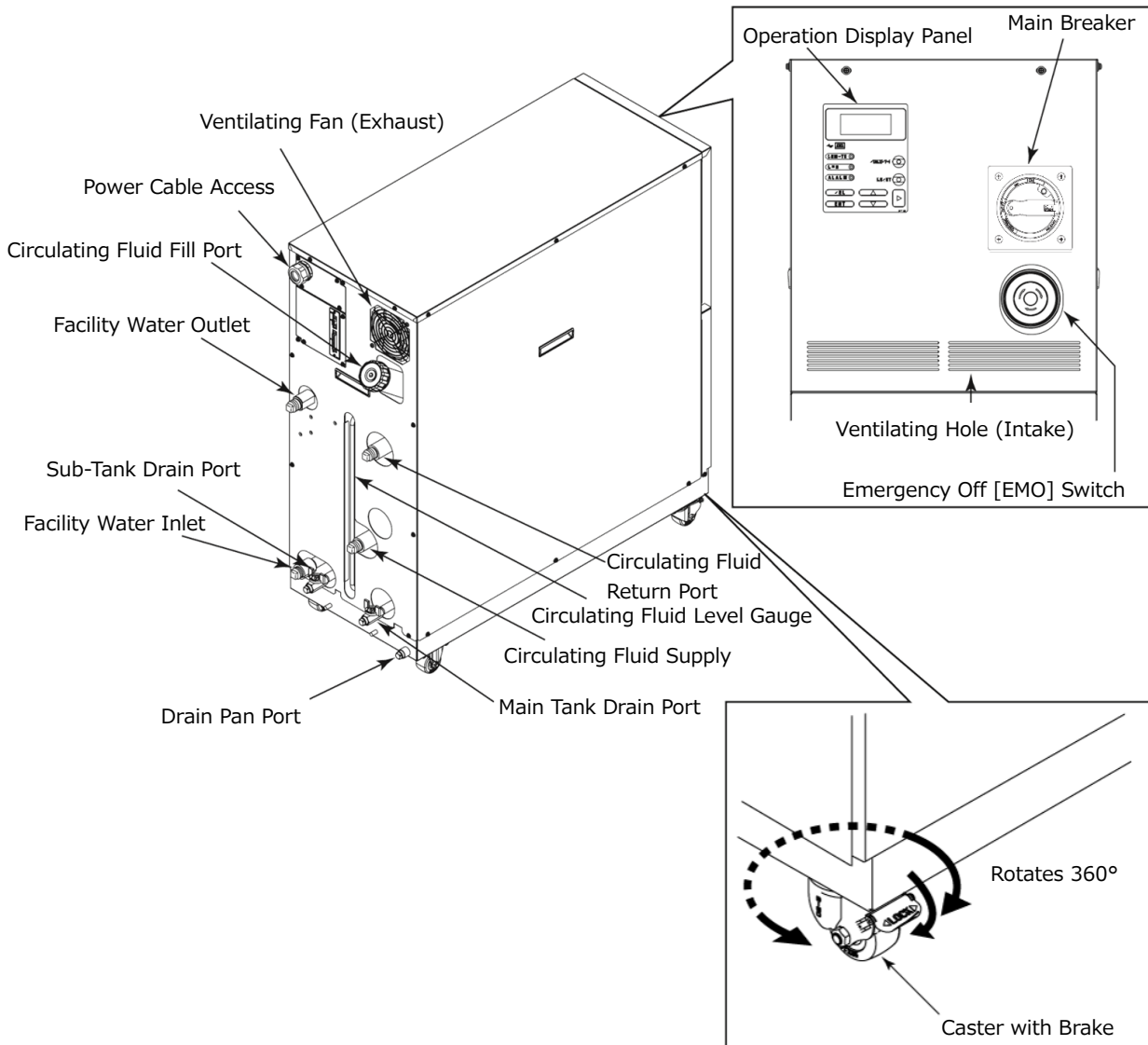

Fig.2-1 Name of Each Section

**[Tips]**

The front casters (2 pcs.) have built-in brakes. The disengagement of the brakes is required when transporting the system.



# Chapter 3 Transporting and Installation

## **WARNING**



Proper procedure must be followed when using this system. Exercise caution to assure personnel safety during the installation, operation, maintenance, and inspection of the system. Only personnel, who have adequate knowledge and experiences with not only this system but associated equipment are allowed to perform transport, installation, and maintenance involving potential hazardous task.

## 3.1 Transporting

This system is heavy, which poses potential danger at transportation. When transporting this system, the following safety precautions should be observed to prevent system damage and breakdown.

## **WARNING**



For transporting with the forklift, be sure to insert the fork into a designated position, referring to “3.1.1 Transporting with Forklift” on page 3-2.

## **CAUTION**



Do not set this system on its side during transportation. Oil in the compressor drains into the refrigerant pipe, which causes lubricant shortages leading to damage to the compressor.

## **CAUTION**



Drain the remaining fluid out of the pipe as much as possible. The remaining fluid may spill if disregarded. Exercise caution not to damage the panel and piping with the forklift when transporting the system.

### 3.1.1 Transporting with Forklift

#### **⚠ WARNING**



Do not set this system on its side for transportation. Potential damage to this system carrying danger of personnel injury if disregarded.  
Do not insert the fork from the back as well as front.

#### **⚠ WARNING**



This system is heavy and requires a forklift to safely move it.  
Forklift insertion positions are on either left or right side of this system.  
Always insert the forks all the way through. Be careful not to hit the casters and adjustable feet.

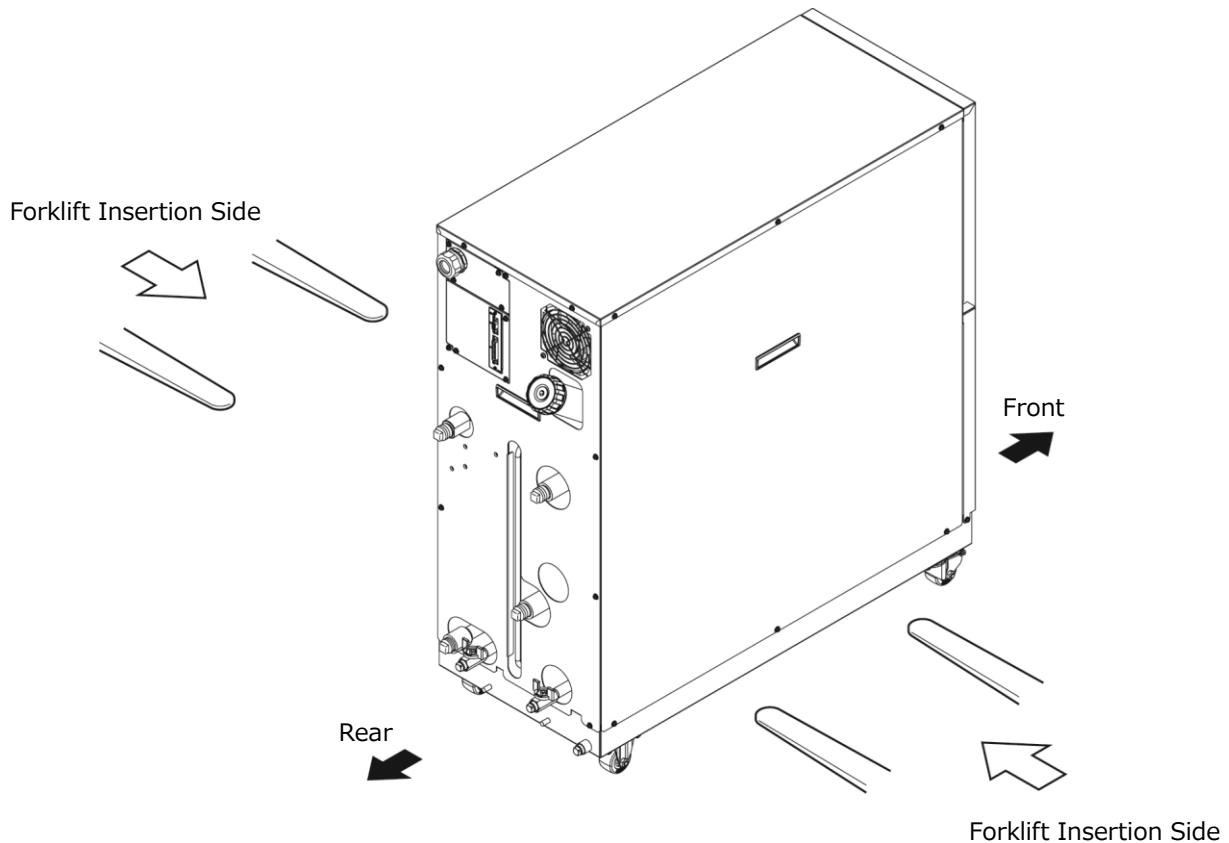

Fig.3-1 Transporting with Forklift



### 3.1.2 Transporting with Caster

#### **WARNING**



This system is heavy, which requires assistance for this work. Exercise caution and look out for sloped surfaces such as ramps, etc.

#### **CAUTION**



Do not grab piping on the back of this system or panel handles when transporting with the casters.

Potential damage to piping and panels may occur if disregarded.

## 3.2 Installation

#### **WARNING**



System installation should be kept from areas with the potential of flammable gas leak. Ignition may occur if leaked gas is collected around the system.

This system is NOT designed for outside use.

Potential electric shock, fire and system damage may occur if exposed to rain, water and dust.

Keep clear of obstruction all ventilation openings in the appliance enclosure or in the structure for building-in.

This product uses flammable refrigerant. Do not install in public hallways or lobbies.

#### **CAUTION**



This system is to be installed on a level floor that can withstand the weight of this system. Potential water leak and personal injury due to system tipping over may occur if disregarded.

This product uses flammable refrigerant. Install it in a place with the following floor space. Floor space 10m<sup>2</sup> or more.

### 3.2.1 Installation Conditions

System installation is not allowed outside or in the conditions described below.

Potential system malfunction and damage may occur if disregarded.

Clean room specifications are not applied to this unit. The pump and ventilating fan installed in this unit generate particles.

- Location that is exposed to water vapor, salt water, and oil
- Location that is exposed to dust and powder
- Location that is exposed to corrosive gas, solvent, and flammable gas
- Location that is exposed to direct sun light or radiant heat
- Location where ambient temperature is out of the following range:
  - In operation            10 to 35 deg. C
  - In storage                0 to 50 deg. C (with no water or circulating fluid in piping)
- Location where relative humidity is out of the following range:
  - In operation            30 to 70%
  - In storage                15 to 85%
- Location that is subjected to abrupt changes in temperature
- Location that is subjected to intense electromagnetic noise (intense electric field, intense magnetic field, or surges)
- Location that is subjected to static electricity, or condition that discharges static electricity to the system
- Location that is subjected to strong high frequencies
- Location that is subjected to potential lightning damage
- Location with altitudes of 1000m or higher
- Location that is affected by strong vibrations or impacts
- Condition that applies external force or weight causing the system deformation
- Condition with no adequate space for maintenance as required in the installation site.
- Places where entry is not restricted to unaffiliated persons
- Places such as public hallways and lobbies

### 3.2.2 Installation Location and Maintenance Work Area

This system does not have ventilating hole on right and left sides. Although this can be installed directly connecting to walls or devices, installation with maintenance space is recommended. (See "Fig.3-2)

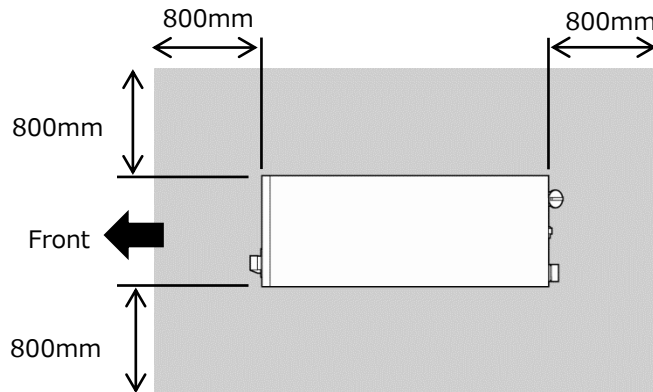

Fig.3-2 Recommended Installation Location

To save space, this system can be installed to allow access only in front and back for daily operation and inspection. For maintenance and repair work, additional access space is required for the left and right side of the system. We recommend a separate repair area, without taking space from installation site, to accommodate the needed extra space.



Fig.3-3 Installation Location

## 3.3 Procedure for Installation

### CAUTION

Anti-seismic bracket is an optional part which is required for the installation of this system (HRZ-TK002).

Preparation of anchor bolts (M12, 4pcs) suitable for floor material is your responsibility. See "8.6 Anchor Bolt Mounting Position" on page 8-17.

### 3.3.1 Installation

- System installation should be on a vibration-free stable level plane.
- See "8.2 Outer Dimensions" on page 8-11 for the dimensions of this system.

### 3.3.2 Procedure for System Securing

- 1 Transfer this system to the installation site.
- 2 Lock the brakes on casters (2 pcs. on the front).
- 3 Using a 13-mm open end wrench, attach the anti-seismic brackets to the front and back.

### CAUTION

Drain pan port is assigned to the bottom on the back of this system. Exercise caution not to damage the drain pan port when attaching the anti-seismic bracket.

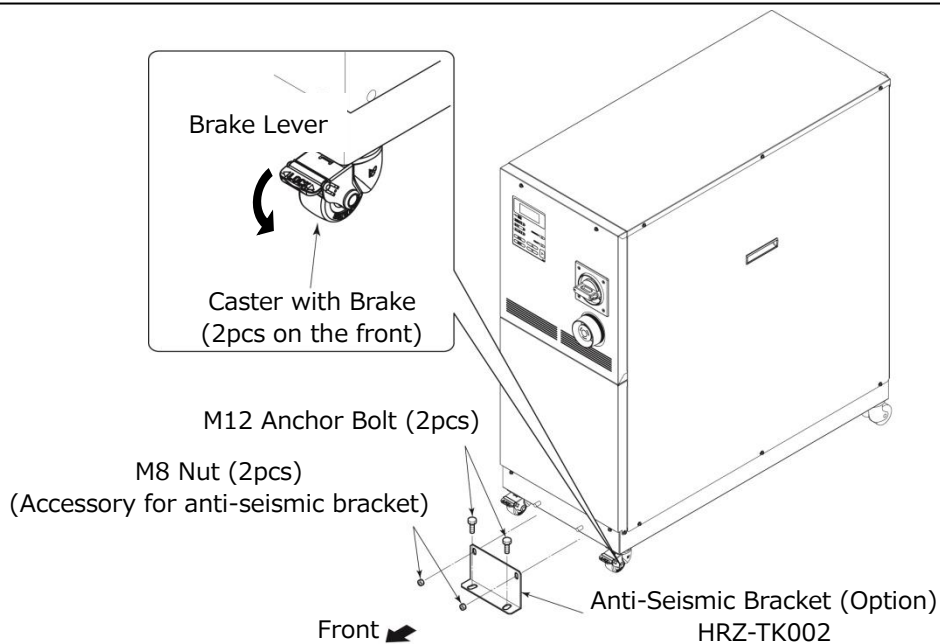

Fig.3-4 Anti-Seismic Bracket

### 3.3.3 Wiring Installation

#### ⚠ WARNING



Only designated personnel are allowed to install wiring.

Be sure to turn OFF the power prior to wiring to assure safety. Do not do any wiring when the system is energized.

The system wiring requires not only a thorough connection with the designated cable but also securing to prevent loose connection. Poor connection and securing may cause electric shock, heat spots, fire or communication errors.

Be sure to supply the power to this system according to specifications.

Supply pure AC power. Potential malfunction may occur if a rectified AC with voltage rise ( $dv/dt$ ) at zero crossing exceeds 40V /200 $\mu$  sec.

Always establish a connection to a ground for safety.

Be sure that no ground connection is made to a water pipe, gas pipe and lighting rod.

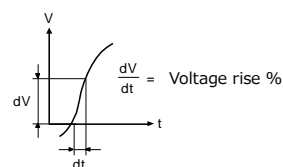

#### ■ Power Cable

The power cables are to be prepared under your responsibility, referring to the following table.

Table 3-1 Power Cable and Main Breaker

Power Cable	Size (Recommended)		10AWG×4-Conductor
	Crimp Contact (recommended)	Breaker	R5.5-8
		Earth Bar	R5.5-8
	Torque (Recommended)	Breaker	6N·m (4.43 ft-lbf)
Earth Bar		12.5N·m (9.22 ft-lbf)	
Main Breaker (This System)			30A

#### ■ Communication Connector

The communication connectors are to be prepared under your responsibility, referring to the following table.

Table 3-2 Communication Connector

Connector	Type (for your system)
Contact Signal (P1 Connector)	D-Sub 25-pin (Male)
Serial RS-485 (P2 Connector)	D-Sub 9-pin (Male)

■ Selection of The Breaker for The Customer’s Equipment (Primary Side)

**⚠ CAUTION**



This product is equipped with the breaker which has different operating characteristics depending on each model. For the customer’s equipment (primary side), use the breaker whose operating time is equal to or longer than the breaker of this product. If the breaker with shorter operating time is connected, the customer’s equipment could be cut off due to the inrush current of the motor of this product.

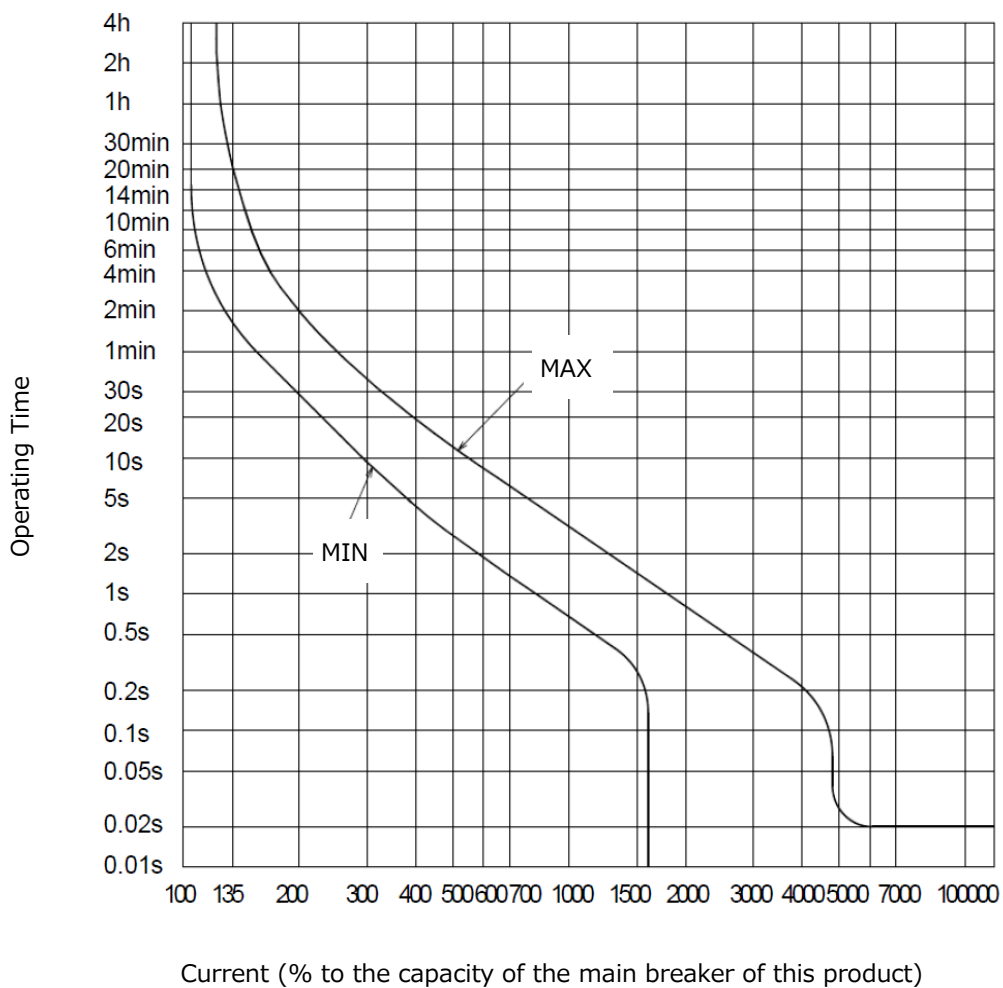

Fig.3-5 Breaker Operating Characteristics Curve

### 3.3.4 Procedures for Wiring Installation

#### **⚠ WARNING**



Be sure to turn OFF the factory side (primary side) power before connection to this system.

Use the assigned procedure to perform lockout/tagout (Page 1-15).

- 1 Turn OFF the power breaker on customer side (primary side), and then use the assigned procedures to perform lockout/tagout.

#### **[Tips]**

Connection of the power cable with this system must be established first. Do not connect the cable with the factory side at this point.

- 2 Turn OFF the main breaker of this system.

- 3 Undo the screws (2 pcs.) to remove the front panel.

Be sure to use a Phillips screwdriver.

- 4 Remove the breaker cover.

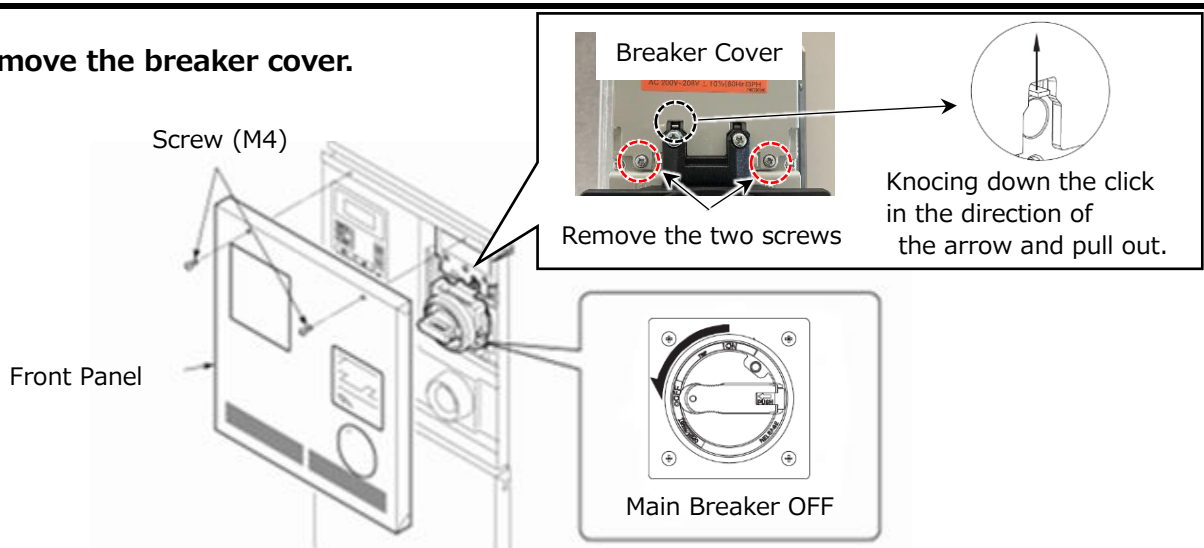

Fig.3-6 Remove The Breaker Cover

#### **[Tips]**

Make sure the breaker is at the 'OFF' position.

Otherwise, the removal of the front panel is not possible.

**5 Loosen the cap at power cable access (strain relief) and insert the power cable.**

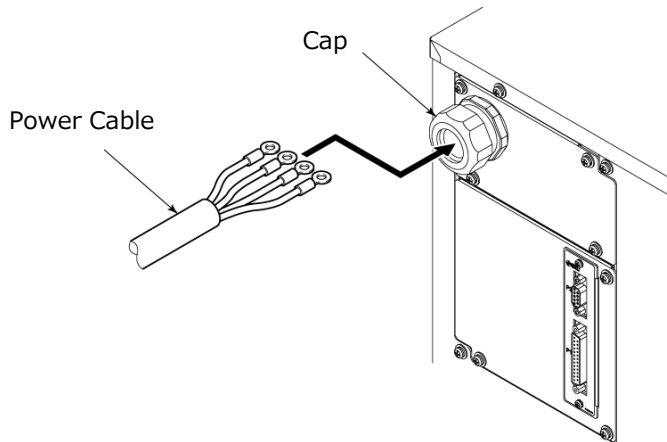



Fig.3-7 Power Cable Insertion

**⚠ CAUTION**



**Correct phase rotation is required when attach the power cable to the breaker terminal.**

**Do not drop a screw or washer in the electrical unit when attaching the breaker cover and terminal.**

**Do not leave it in the unit if dropped in. Potential failure may occur if the power is turned ON without removing it.**

**6 Connect the power cables to the breaker terminal.**

Be sure to use a Phillips screwdriver. (Recommended torque is 6N·m(4.43ft-lbf))

**7 Connect the grounding terminal (M8) of the power cable to the earth bar.**

Be sure to use a 13-mm open end wrench.

Recommended torque: 12.5 N·m (9.22 ft-lbf)

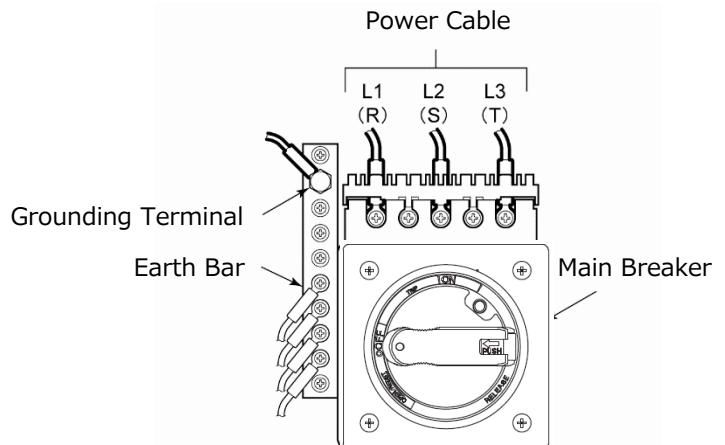

Fig.3-8 Connection of Power Cable



---

**8 Attach the breaker cover to the breaker.**

Align the terminal cover with the barrier mounting groove on the breaker body and push it all the way in.

Fasten the screws (2 pcs) (recommended torque 0.5 to 0.6 N-m).

---

**9 Attach the front panel.**

---

**10 Connect the power cable to the power breaker on customer side (primary side).**

---

**11 Connect the communication cables with P1 and P2.**

Fig.3-9 Signal Line Mounting

### 3.3.5 Installation of Circulating Fluid and Facility Water Piping

#### **⚠ CAUTION**

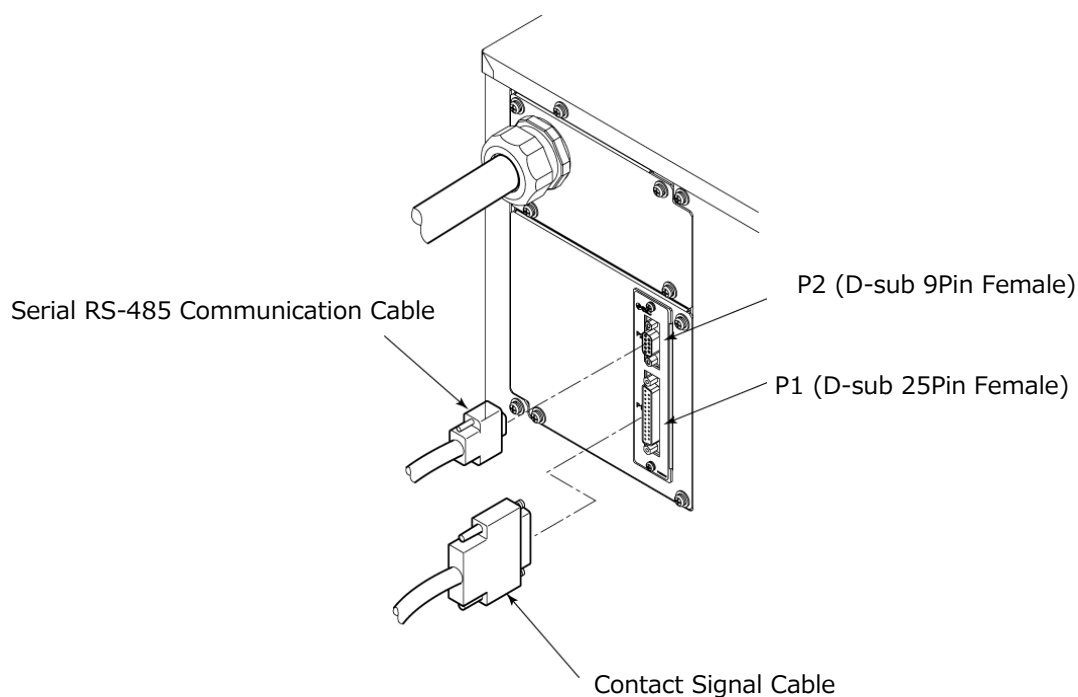

Regarding the circulating fluid and facility water pipings, consider carefully the suitability for operating pressure, temperature circulating fluid and facility water. If the operating performance is not sufficient, the pipings may burst during operation. Also, the use of corrosive materials such as aluminum or iron for fluid contact parts, such as piping, may not only lead to clogging or leakage in the circulating fluid and facility water circuits but also refrigerant leakage and other unexpected problems. provide protection against corrosion when you use the product.

Always insulate external circulating piping. Potential insufficient cooling performance due to heat absorption from the pipe surface and potential insufficient heating performance caused by thermal radiation if disregarded.

When using fluorinated liquid as the circulating fluid, do not use pipe tape. Liquid leakage may occur around the pipe tape. for sealant, we recommend that you use the following sealant: SMC Part No., HRZ-S0003 (Silicone sealant)

Use clean pipes and pipe fittings, free of particles, oil and moisture. Apply air blow to the parts before using. The presence of particles, oil or moisture in the circulating fluid circuit causes insufficient cooling, system failure attributed to moisture freeze when entering the system, or foaming of the circulating fluid in the tank.

The total capacity of circulating fluid required by external piping should remain under the capacity of the sub tank. Potential problem of tank overflow, when pump stop, may occur if disregarded. See "8.1.1 System Specification" on page 8-1.

Be sure to choose a circulating fluid pipe capable of letting the fluid flow at rated flow rate or better. See "8.1.1 System Specification" on page 8-1 for the flow rate rating.

Have a drip pan available incase of a fluid leak.

Do not return the circulating fluid to the unit by installing a pump in the user system.

Make sure of the locations of ports for the circulating fluid supply, return, facility water inlet, outlet and their corresponding connections are correct. Secure the piping connector section with a pipe wrench, and provide proper tightening to the pipe.

Do not give an impact when the piping connector section is fixed or tightened. It may damage the piping or cause leakage.

The flow rate of the facility water is automatically adjusted depending on using conditions. The facility water outlet temperature can be up to 60 deg. C

Any fluid circuits connected to the appliance shall safely release abnormal pressure.

It shall not allow the release of **FLAMMABLE REFRIGERANT** into areas served by the other circuits if these do not comply with minimum room area limit.

## ■ Piping Diameter

Tabel 3-3 Piping Diameter

Pipe	Diameter	Recommended Torque (Material: SS* vs SS)
Facility Water Inlet	Rc1/2	28 to 30N·m (20.7 to 22.1ft-lbf)
Facility Water Outlet	Rc1/2	28 to 30N·m (20.7 to 22.1ft-lbf)
Circulating Fluid Supply	Rc3/4	60 to 65N·m (44.3 to 47.9ft-lbf)
Circulating Fluid Return	Rc3/4	60 to 65N·m (44.3 to 47.9ft-lbf)
Main Tank Drain Port	Rc3/8 (with valve)	Piping not necessary
Sub-tank Drain Port	Rc3/8 (with valve)	Piping not necessary
Drain Pan Port	Rc3/8	Piping not necessary

\*: SS Stainless steel

## ■ Procedure for Piping Installation

Secure the pipe coupling section with a pipe wrench and provide proper tightening to the pipe.

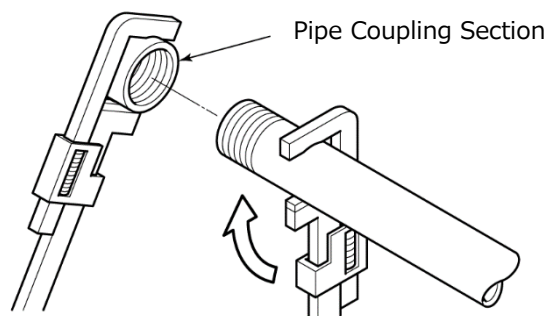

Fig.3-10 Pipe Tightening

■ Recommended Piping Installation

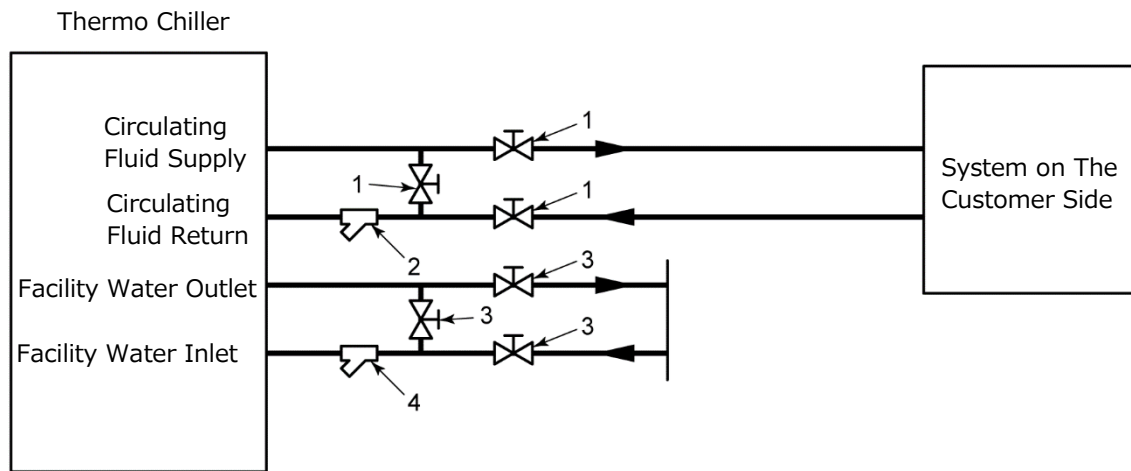

Fig.3-11 Recommended Piping Installation

Table 3-4 Recommended Pipe

No.	Name	Size	Material
1	Valve	Rc3/4	Stainless Steel
2	Filter (100μm)	Rc3/4	Stainless Steel
3	Valve	Rc1/2	Stainless Steel
4	Filter (5μm)	Rc1/2	Stainless Steel

### 3.3.6 Facility Water

#### **⚠ CAUTION**



No thermal insulator is assigned to facility water circuit. In order to avoid dew condensation of facility water circuit, retain the facility water temperature inside the range in Table 3 5 correspond to installation conditions. Otherwise please insulate the facility water piping by customer.

Table 3-5 Facility Water Temperature Range

Installation Conditions		Facility Water Temperature Range (deg. C)
Ambient Temperature (deg. C)	Relative Humidity(%)	
35	70	29 to 30
	60	27 to 30
	50	24 to 30
	40	20 to 30
	30	15 to 30
30	70	24 to 30
	60	22 to 30
	50	19 to 30
	40	15 to 30
	30	11 to 30
25	70	20 to 30
	60	17 to 30
	50	14 to 30
	40	11 to 30
	30	10 to 30
20	70	15 to 30
	60	13 to 30
	50	10 to 30
	40	
	30	
15	70	10 to 30
	60	
	50	
	40	
	30	
10	70	10 to 30
	60	
	50	
	40	
	30	



# Chapter 4 System Startup and Shutdown

## ⚠ CAUTION



Only personnel, who have adequate knowledge of and experiences with not only this system but associated equipment, are allowed to implement system startup and shutdown.

## 4.1 Pre-check

Check the following items prior to starting up the system.

### 4.1.1 Installation Condition

- Make sure that the system is installed in a horizontal position.
- No heavy object is placed on this system. This system should not be applied with an undue force such as caused by piping installation.
- Re-check the items defined in "3.2 Installation" on page 3-3.

### 4.1.2 Cable Connection

Make sure proper connection of the power cable, ground, and communication cables.

### 4.1.3 Installation of Circulating Fluid and Facility Water Piping

Make sure that circulating fluid and facility water piping are installed properly.

### 4.1.4 Operating Signal from Your System

Make sure that no remote signal is being issued from your system. System startup takes effect upon power-ON if this system receives a remote signal and it is in remote mode.

### 4.1.5 Check Emergency Off [EMO] Switch

Make sure of the location of the emergency off [EMO] switch before operating the system. See "1.7.1 Emergency Off [EMO] Switch" on page 1-18.

## 4.2 Opening of Facility Water Valve

## CAUTION



Check that the facility water complies with not only the water quality standard defined in "7.1 Water Quality Management" on page 7-1 but the requirements provided in "8.1.1 System Specification" on page 8-1.

Open the facility water valve for water supply.

### [Tips]

This system is outfitted with a water regulating valve inside. Facility water may not flow upon system startup which is normal.

## 4.3 Supply of Circulating Fluid

### ⚠ CAUTION



Circulating fluids to use vary with system models.

See "8.1.1 System Specification" on page 8-1 for the designated circulating fluid for a specific model.

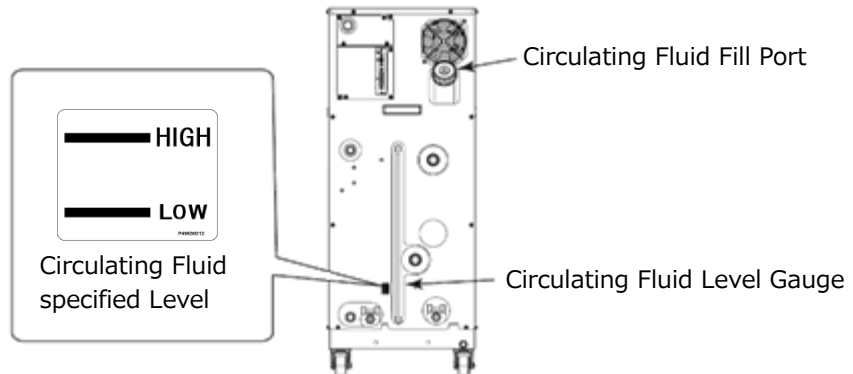

Fig.4-1 Circulating Fluid Fill Port and Circulating Fluid Level Gauge

### 4.3.1 Preparation of Circulating Fluid

#### ■ When the Circulating Fluid Is a Fluorinated Fluid

### ⚠ CAUTION

Make sure of no oil, moisture, and other foreign materials contaminate the circulating fluid. Potential cooling error or system failure, due to contaminant freezes internally, may occur if disregarded.

#### ■ When The Circulating Fluid Is a 60% Ethylene Glycol Aqueous Solution

### ⚠ CAUTION

Low concentration EG in the circulating fluid may cause system failure due to it being frozen in the system.

High concentration EG in the circulating fluid may cause circulating pump overload, which triggers "Return Low Flow FLT".

Potential cooling error may occur if the circulating fluid varies in concentration.

Foreign matter or other contaminants in the circulating fluid can cause malfunctions.



### 4.3.2 Supply of Circulating Fluid

Remove the circulating fluid fill cap and fill the circulating fluid until it reaches its specified level.

The circulating fluid specified level is a range between "HIGH" and "LOW" in Figure 4-1.

Be sure to tighten the cap until it clicks after fluid supply.

If the circulating fluid is supplied over the specified level, follow the procedure provided in "7.3.1 Draining of Circulating Fluid Out of Tank" on page 7-4 to drain excess fluid until it reaches the specified level.

#### [Tips]

Level between "HIGH" and "LOW" represent liquid level in normal running condition. Immediately as you start filling up the chiller, the internal transferring pump start pumping fluid from the Sub Tank into the Main Tank. Thus, the fluid level in the level gauge will start to drop. During initial running of the external piping, addition fluid is needed. See "8.1.1 System Specification" on page 8-1 for tank capacity.

#### **WARNING**



Circulating fluid must be supplied to be in the range between "HIGH" and "LOW". Potential overflow of hot circulating fluid may occur due to excessive volume.

Total fluid volume use to fill up the system including initial priming should not exceed combined volume of Sub Tank and Main Tank.

If level is below the "LOW" mark, this system will trigger an alarm.

#### **CAUTION**



When supplying the circulating fluid, make sure that the fluid inside this system has dropped to room temperature for the prevention of burns.

#### **CAUTION**



To prevent moisture, which is formed by condensation of a flowed air, from finding its way into the tank, ensure the circulating fluid at room temperature when supplying the fluid.

Be sure to tighten the cap until it clicks after fluid supply.

Potential circulating fluid vaporization or moisture intrusion due to condensation of flowed air may occur if disregarded.

## 4.4 Requirement for System Startup

### 4.4.1 Turning ON Power

**1** Make sure that the main breaker for this system is OFF, and release lockout/tagout of the power breaker on customer side (primary side). Then, turn ON the power.

**2** Turn ON the main breaker of this system.

The "Model Indication screen" and "System Information screen" are displayed in sequence on the LCD screen. The screen will change to the "Status screen 1" for approx. 5 seconds and the system is ready to run.

#### [Tips]

It is normal if the "System Information screen" is not displayed. See "5.3.33 Status Screen 1" on page 5-35 for details.

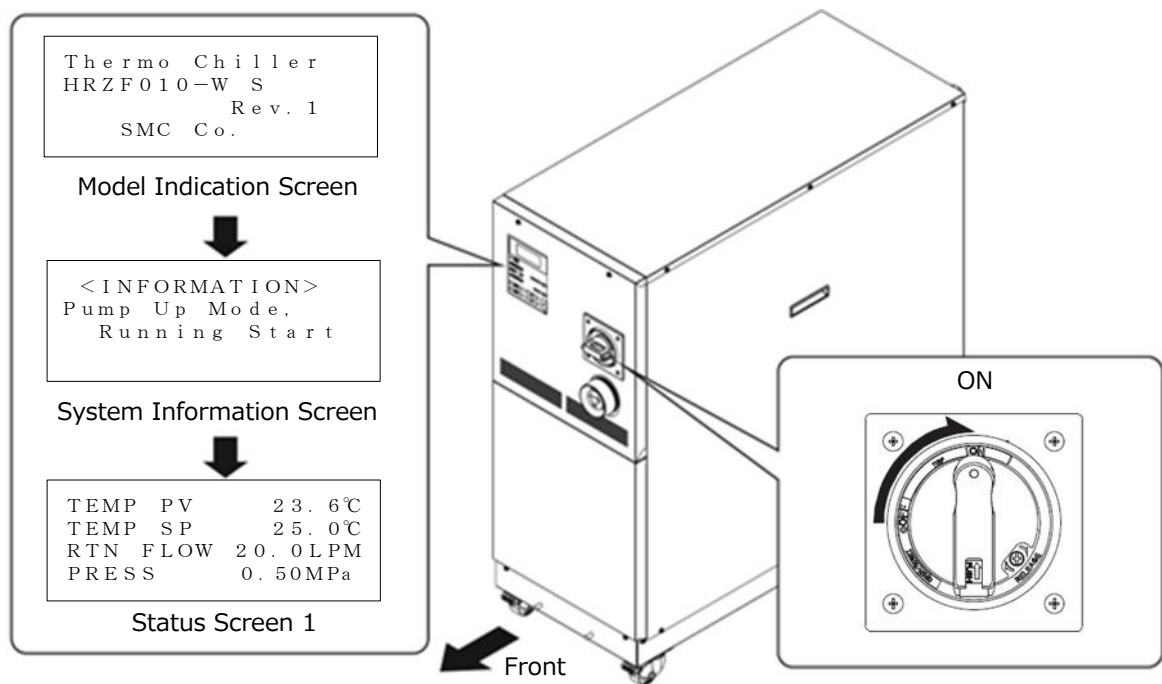

Fig.4-2 Main Breaker at ON

### **WARNING**



Press the emergency off [EMO] switch immediately upon occurrence of abnormal conditions. Be sure to turn OFF the main breaker afterwards.

## 4.4.2 Circulating Fluid Temperature Setting

From the "Setting screen" on the LCD screen, set the circulating fluid at any temperature. See "5.4 Examples of System Operation" on page 5-36 for operating procedure.

## 4.5 System Startup and Shutdown

### 4.5.1 System Startup

Press the [START/STOP] key on the operation display panel.

The [RUN] lamp on the operation display panel comes on, and the "System Information screen" is flashing. The screen then changes to the "Status screen 1", which initiates system operation.

#### [Tips]

It is normal if the "System Information screen" is not displayed. See "5.3.33 System Information Screen" on page 5-35 for details.

### 4.5.2 System Shutdown

Press the [START/STOP] key on the operation display panel.

The "System Information screen" is flashing on the LCD screen, and the [RUN] lamp comes on. The compressor comes to a halt approx., 20 seconds after circulating pump stop for protection of the compressor. The screen is returned to the "Setting screen 1", which prompts the [RUN] lamp to go out.

#### [Tips]

See "5.3.33 System Information Screen" on page 5-35 for details.

### CAUTION



Internal equipment may remain at elevated or lowered in temperature immediately after system shutdown. Potential burns or frostbite may happen if your skin comes in contact with these surfaces. Further work is allowed only when the system reaches room temperature

### CAUTION



Emergency off [EMO] switch and main breaker (OFF) should not be used for system shutdown unless it is an emergency.



# Chapter 5 System Operation

## 5.1 Operation Display Panel

Use the operation display panel located in front of the system for the basic operations.

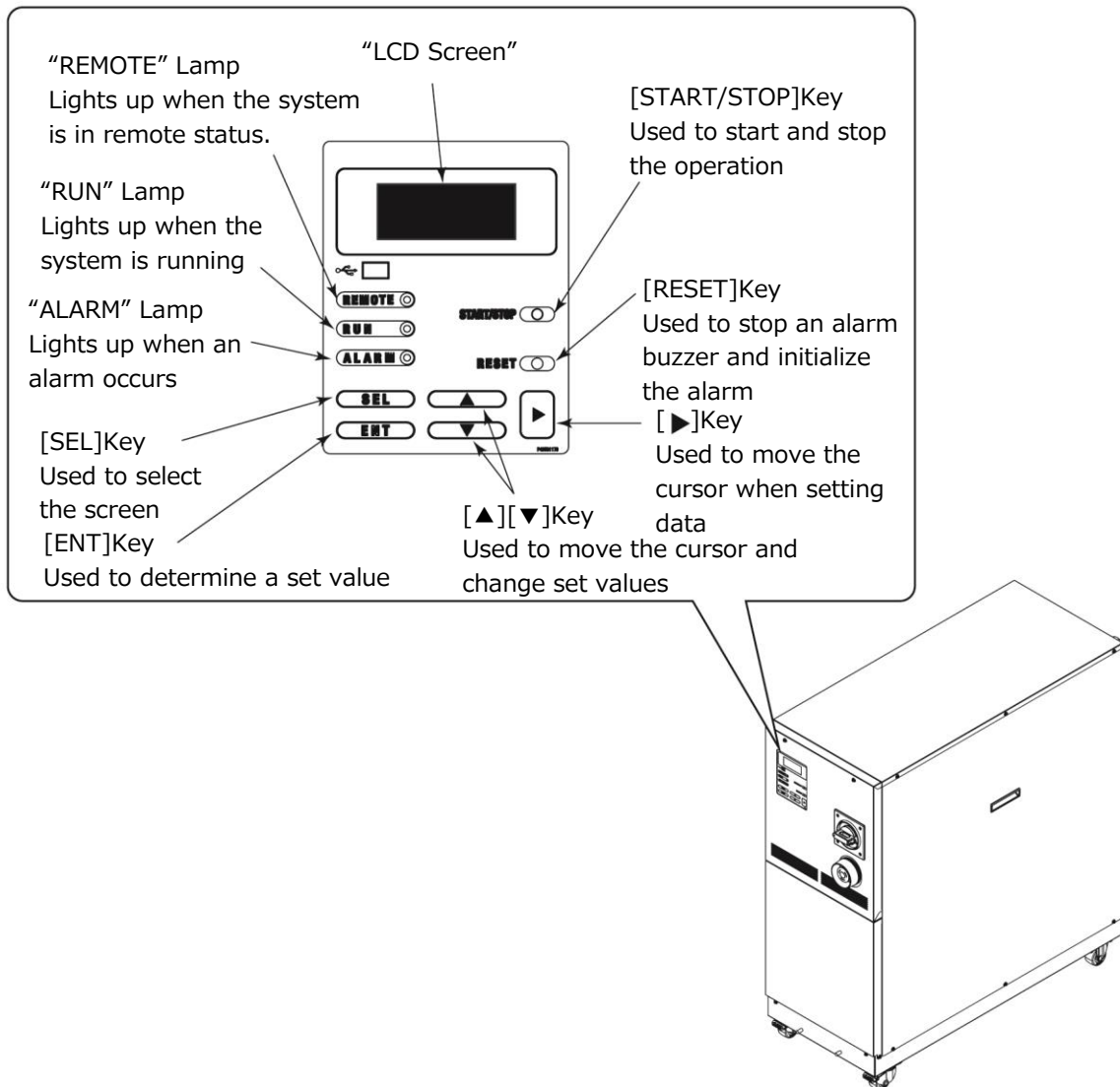

Fig.5-1 Operation Display Panel

### CAUTION

Be sure to use your fingers only to operate the Operation Display Panel.  
Using sharp object will damage the panel

# 5.2 Flow Chart of Operation Screen

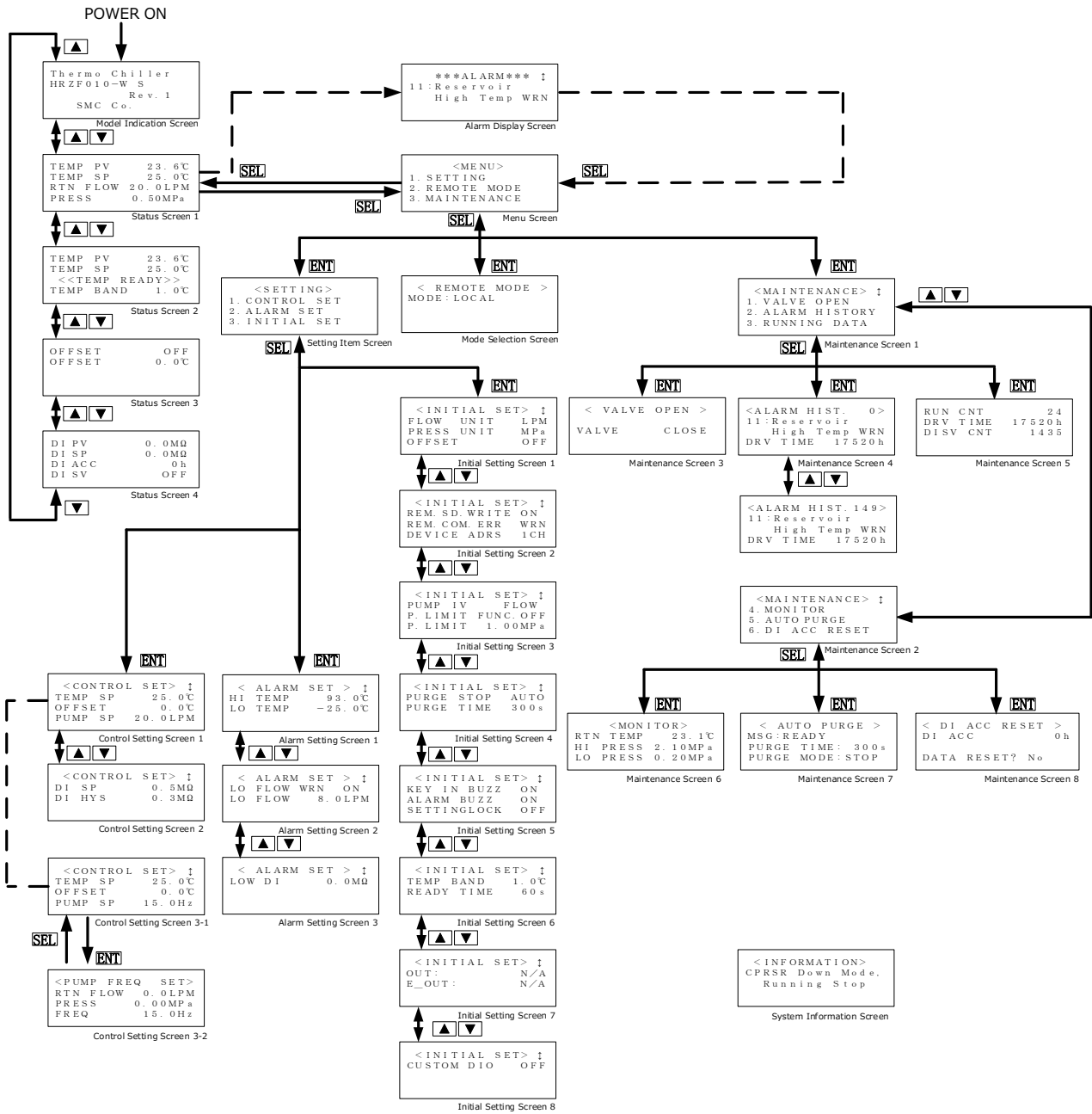

Fig.5-2 Flow Chart of Operation Screen

**[Tips]**

After the menu screen, pressing the [SEL] key can make the screen return to the previous page.

For the items which are set numerically can be set by minimum unit of displayed value.

The contents displayed on the screen may change depending on the options or settings. Please refer to the description page of each screen

Table 5-1 Descriptions of Operation Screens

Screen	Descriptions	Reference
Model Indication Screen	Displays the model and revision No. of this system.	Page 5-4
Status Screen 1 to 4	Displays the operating condition of this system.	Page 5-5 to 5-8
Alarm Display Screen	The alarm number and alarm message are displayed in the event of an error in this system. Not displayed if no error.	Page 5-9
Menu Screen	Allows setting screen selection	Page 5-9
Setting Screen	Allows switching to "Control Setting screen", "Alarm Setting screen" and "Initial Setting screen".	Page 5-10
Control screen 1, 2, 3-1, 3-2	Allows the setting of pump frequency, pressure or flow rate by pump inverter.	Page 5-10 to 5-14
Alarm Setting Screen 1 to 3	Allows the setting of set values for the alarm of temperature and flow rate.	Page 5-15 to 5-17
Initial Setting Screen 1 to 8	Allows the setting of set values.	Page 5-18 to 5-25
Mode Selection Screen	Allows communication mode selection.	Page 5-26
Maintenance Screen 1 to 8	Not used during system operation. Not allowed to use unless otherwise specified.	Page 5-27 to 5-34
System Information Screen	Displays the status of system startup and shutdown.	Page 5-35

## 5.3 Operation Screen

### 5.3.1 Model Indication Screen

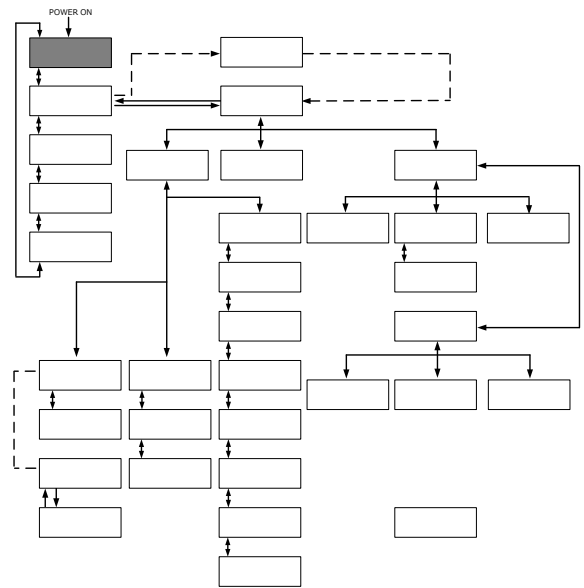
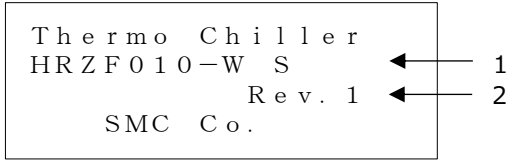

Fig.5-3 Model Indication Screen

Table 5-2 「Model Indication Screen」

No.	Item	Descriptions
1	—	System model
2	—	System revision No.

#### 【Tips】

When power is turned on to the product, the "Model Display Screen" appears.

After approximately 5 seconds of display, the display automatically switches to "Status Screen 1".

If there is an abnormality in the product, the display switches to the "Alarm Screen".



### 5.3.2 Status Screen 1

TEMP PV	23.6°C	← 1
TEMP SP	25.0°C	← 2
RTN FLOW	20.0 LPM	← 3
PRESS	0.50 MPa	← 4

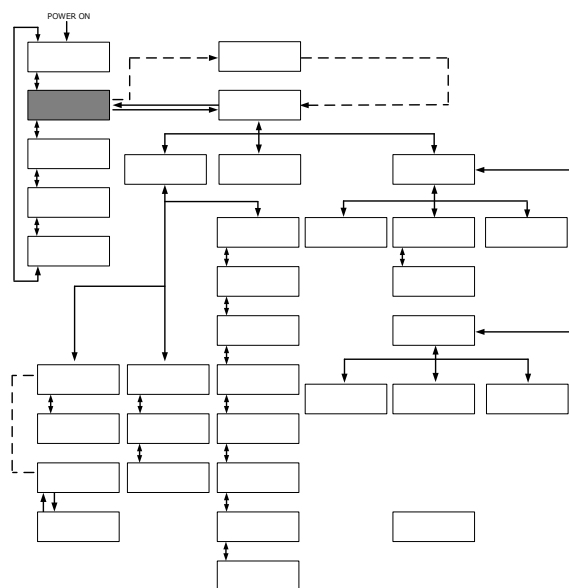

Fig.5-4 Status Screen 1

Table 5-3 [Status Screen 1]

No.	Item	Descriptions
1	TEMP PV	Discharge temperature of the circulating fluid (A value derived according to the offset* <sup>1</sup> if applied)
2	TEMP SP	Set value of circulating fluid discharge temperature
3	RTN FLOW	Return flow rate of the circulating fluid
4	PRESS	Discharge pressure of the circulating fluid

#### [Tips]

See "8.4 Offset Function" on page 8-13 for details on offset (\*1).  
RTN FLOW and PRESS units cannot be changed.

### 5.3.3 Status Screen 2

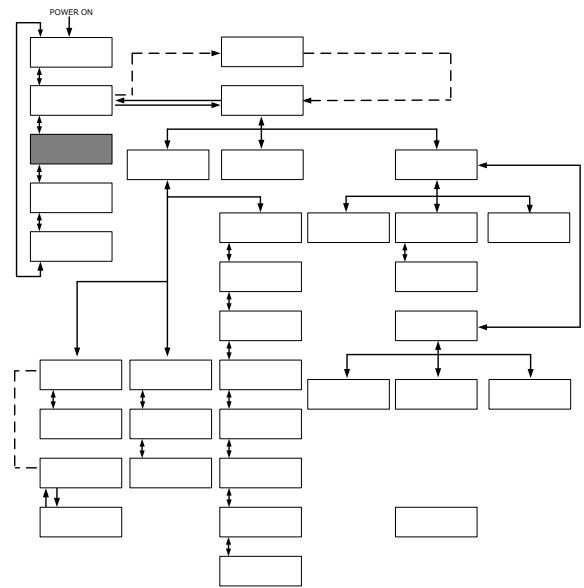
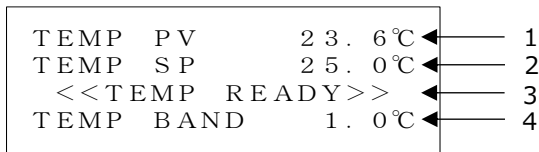

Fig. 5-5 Status Screen 2

Table 5-4 [Status Screen 2]

No.	Item	Descriptions
1	TEMP PV	Discharge temperature of the circulating fluid
2	TEMP SP	Set circulating fluid temperature
3	<<TEMP READY>>	Displays the BAND/READY [Displayed when set value conditions are satisfied] *1
4	TEMP BAND	Set value of BAND range *1

**[Tips]**

See "8.5 BAND/READY" on page 8-16 (\*1).

### 5.3.4 Status Screen 3

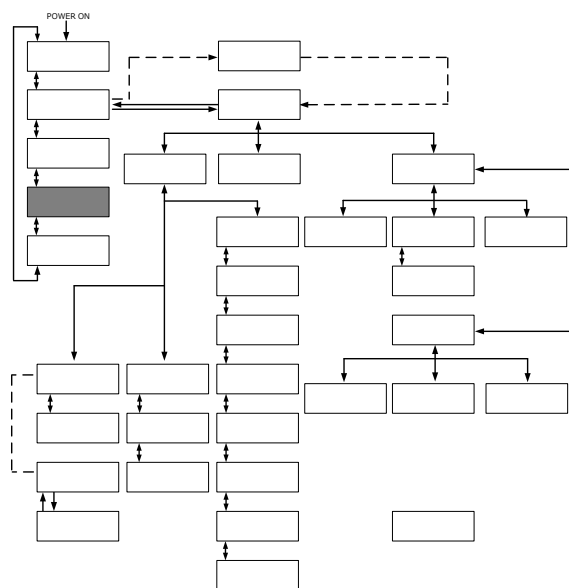
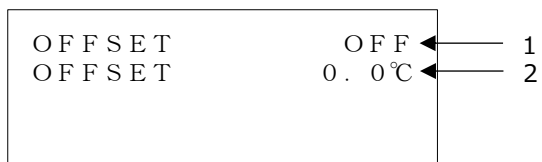

Fig.5-6 Status Screen 3

Table 5-5 「Status Screen 3」

No.	Item	Descriptions
1	OFFSET	The current offset mode *1
2	OFFSET	Set offset

**[Tips]**

See "8.4 Offset Function" page 8-13 on offset features (\*1).

### 5.3.5 Status Screen 4

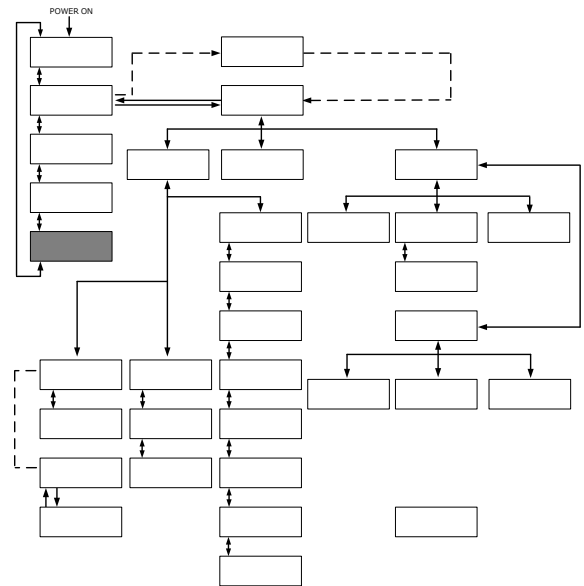
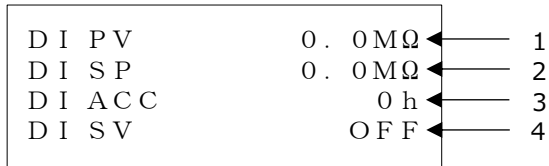

Fig.5-7 Status Screen 4

Table 5-6 「Status Screen 4」

No.	Item	Descriptions
1	DI PV	Circulating fluid electric resistivity.
2	DI SP	Set value of circulating fluid electric resistivity.
3	DI ACC	Accumulated time that the solenoid valve in DI circuit is activated.
4	DI SV	Open/close status of solenoid valve in DI circuit.

**[Tips]**

It is displayed only if the DI Control Kit (optional) is provided.

### 5.3.6 Alarm Display Screen

```

***ALARM*** ↓
11:Reservoir
High Temp WRN
    
```

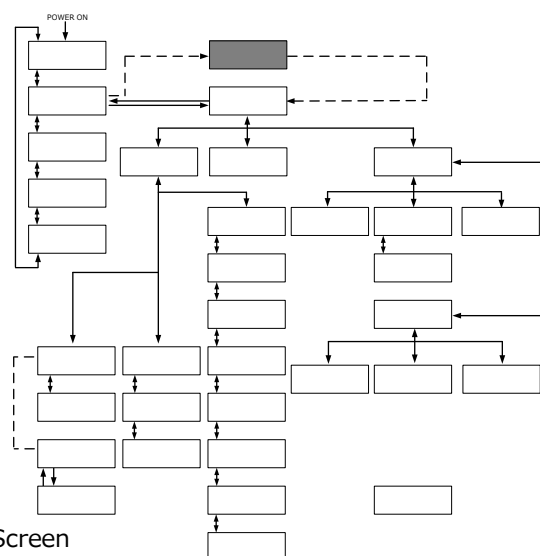

Fig.5-8 Alarm Display Screen

In the event of an error in this system, the current screen is switched to the “Alarm Display screen” to display the relevant alarm code and message. The “Alarm Display screen” is displayed only if an error is raised. See “6.2 Troubleshooting” on page 6-2 for alarm numbers and messages.

### 5.3.7 Menu Screen

```

<MENU>
1. SETTING ← 1
2. REMOTE MODE ← 2
3. MAINTENANCE ← 3
    
```

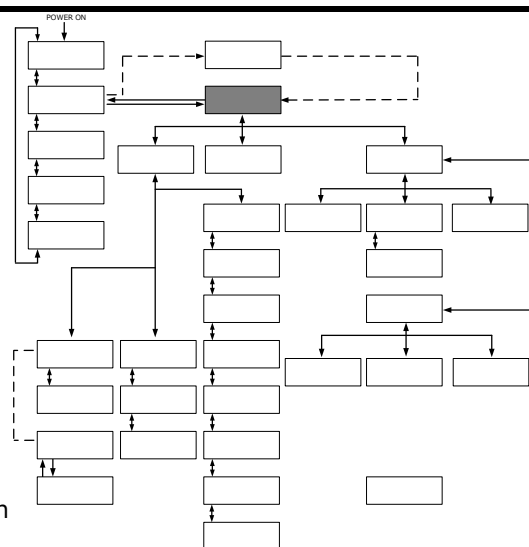

Fig.5-9 Menu Screen

Table 5-7 「Menu Screen」

No.	Item	Descriptions
1	SETTING	Switches to the “Setting Screen” with the press of the [ENT] key.
2	REMOTE MODE	Switches to the “Mode Selection Screen” with the press of the [ENT] key.
3	MAINTENANCE	Switches to the “Maintenance Screen 1” with the press of the [ENT] key.

**[Tips]**

[▲] or [▼] key is used for selecting “Item”.

### 5.3.8 Setting Screen

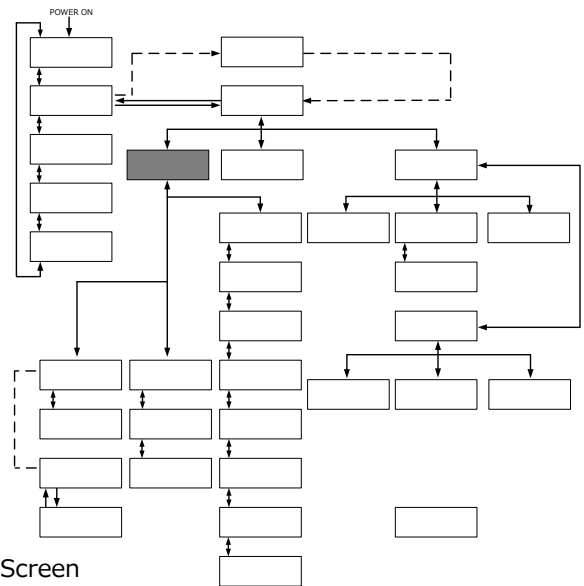
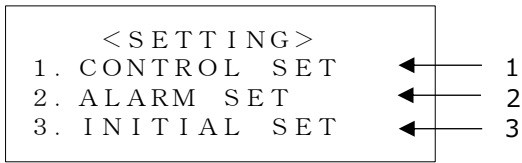

Fig.5-10 Setting Screen

Table 5-8 [Setting Screen]

No.	Item	Descriptions
1	CONTROL SET	Switches to the "Control Setting Screen 1" with the press of the [ENT] key.
2	ALARM SET	Switches to the "Alarm Setting Screen 1" with the press of the [ENT] key.
3	INITIAL SET	Switches to the "Initial Setting Screen 1" with the press of the [ENT] key.

**[Tips]**

[▲] or [▼] key is used for selecting "Item".

### 5.3.9 Control Setting Screen 1

This screen is displayed if the PUMP IV is set to PRESS or FLOW on the "5.3.18 Initial Setting Screen 3". If PUMP IV is set to FREQ, this screen is not displayed and Control Setting Screen 3-1 (page 5-13 ) is displayed.

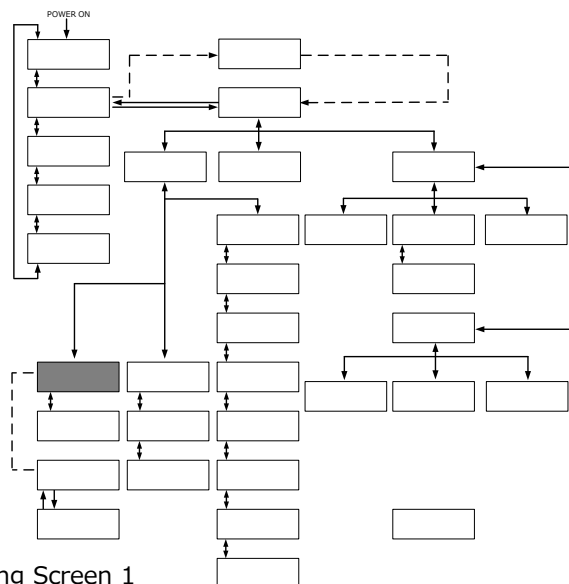
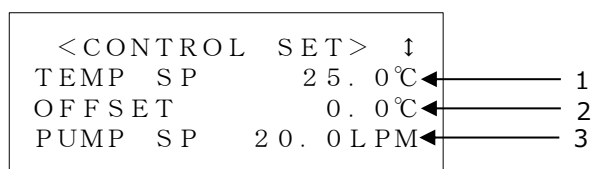

Fig.5-11 Control Setting Screen 1

Table 5-9 「Control Setting Screen 1」

No.	Item	Descriptions	Setting Range	Factory Default
1	TEMP SP	Allows the setting of circulating fluid discharge temperature.	-20.0 to 90.0deg. C	25.0deg. C
2	OFFSET	Allows the setting of OFFSET value* 1	-20.0 to 20.0deg. C	0.0deg. C
3	PUMP SP	Switched to the "5.3.12 Control Setting Screen 3-2" (Pump frequency setting screen.)	10.0 to 40.0LPM	20.0LPM
			0.10 to 1.00MPa	0.10MPa

#### 【Tips】

In the case of using Offset Function, select any one of MODE 1 to 3 on No.3 of "8.4 Offset Function" (page 8-13) for details (\*1).

[▲] or [▼] key is used for selecting "Item." And pressing [ENT] key enabling changing the set point.

### 5.3.10 Control Setting Screen 2

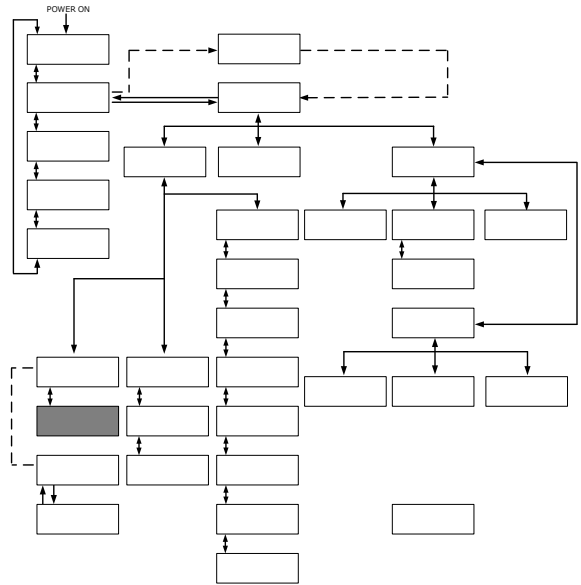
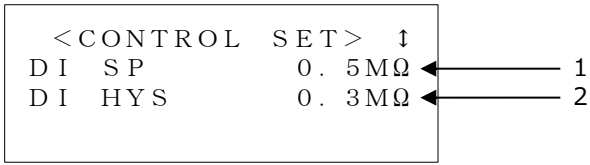

Fig.5-12 Control Setting Screen 2

Table 5-10 「Control Setting Screen 2」

No.	Item	Descriptions	Setting Range	Factory Default
1	DI SP	Allows the setting of circulating fluid electric resistivity.	0.0 to 2.0MΩ	0.5MΩ
2	DI HYS	Allows the setting of hysteresis for circulating fluid electric resistivity. (See Figure 5-13 about hysteresis.)	0.0 to 0.9MΩ	0.3MΩ

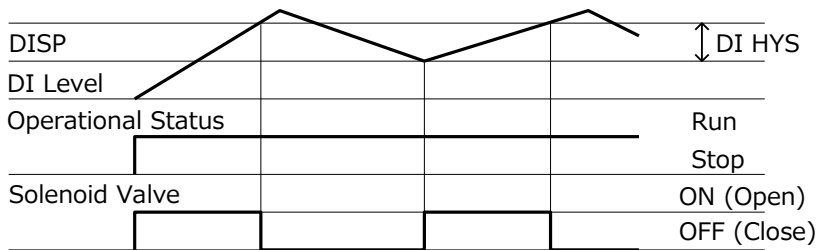

Fig.5-13 DI Hysteresis Setting (DI HYS)

**[Tips]**

It is displayed only if the DI Control Kit (optional) is provided.  
 [▲] or [▼] key is used for selecting "Item." and move to the other Control Setting screens. And pressing [ENT] key enabling changing the set point.



### 5.3.11 Control Setting Screen 3-1

This screen is displayed if the PUMP IV is set to FREQ on the "Initial Setting Screen3". If PUMP IV is set to PRESS or FLOW, this screen will not be displayed and 5.3.9 Control Setting Screen 1 (page 5-11) will be displayed.

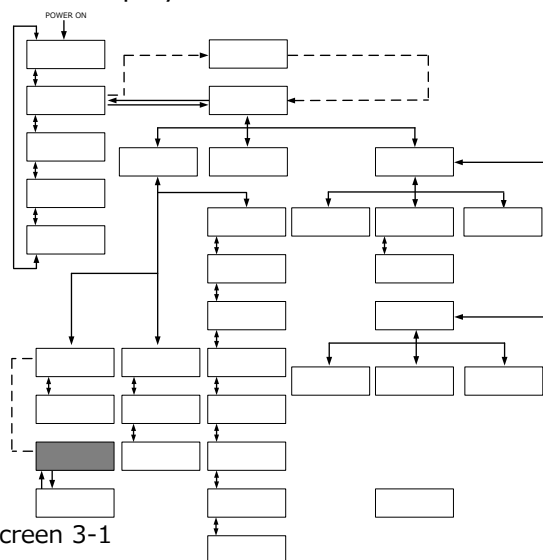
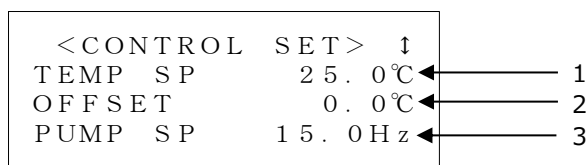

Fig.5-14 Control Setting Screen 3-1

Table 5-11 [Control Setting Screen 3-1]

No.	Item	Descriptions	Setting Range	Factory Default
1	TEMP SP	Circulating fluid temperature can be set.	-20.0 to 90.0deg. C	25.0deg. C
2	OFFSET	Allows the setting of OFFSET value* 1	-20.0 to 20.0deg. C	0.0deg. C
3	PUMP SP	Switched to the "Control Setting Screen 3-2". (Pump frequency setting screen.)	-	-

#### [Tips]

In the case of using Offset Function, select any one of MODE 1 to 3 on No.3 of "8.4 Offset Function" on page 8-13 for details (\*1).

[▲] or [▼] key is used for selecting "Item." And pressing [ENT] key enabling changing the set point.

### 5.3.12 Control Setting Screen 3-2

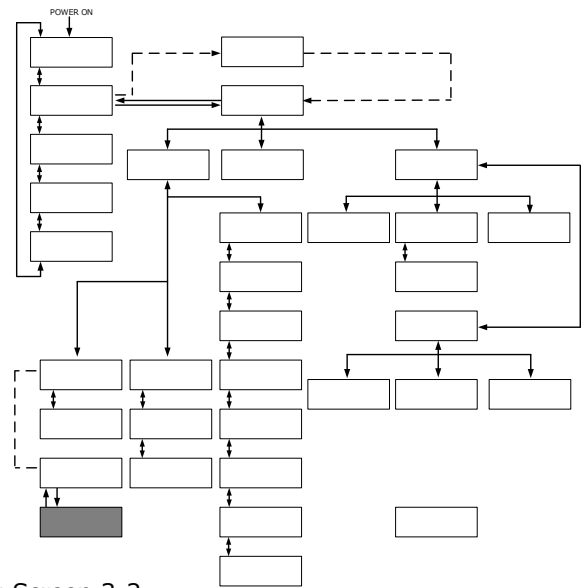
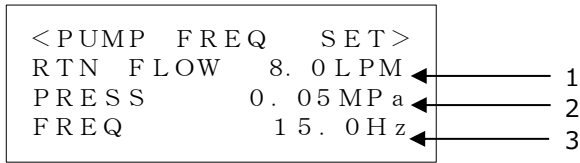

Fig.5-15 Control Setting Screen 3-2

Table 5-12 [Control Setting Screen 3-2]

No.	Item	Descriptions	Setting Range	Factory Default
1	RTN FLOW	Return flow rate of circulating fluid.	-	-
2	PRESS	Discharge pressure of circulating fluid.	-	-
3	FREQ	Allows the setting of pump frequency. ("Control Setting Screen 3-2" is displayed only if PUMP IV on "Initial Setting screen 3" is set to FREQ.)	15.0 to 60.0Hz	15.0Hz

**[Tips]**

Pressing [ENT] key enabling to change the set point of FREQ.

### 5.3.13 Alarm Setting Screen 1

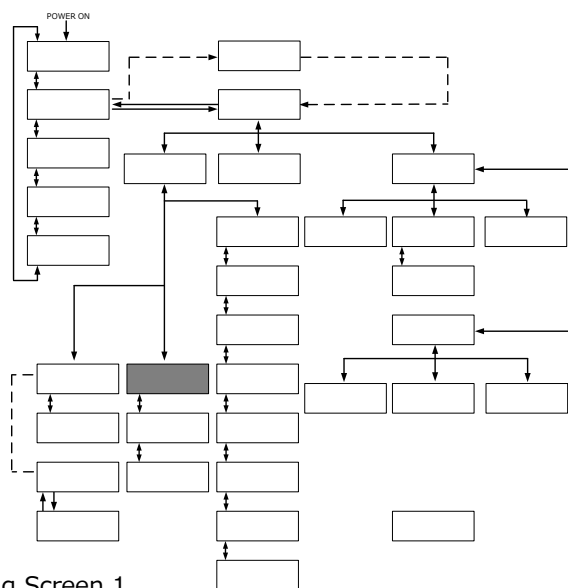
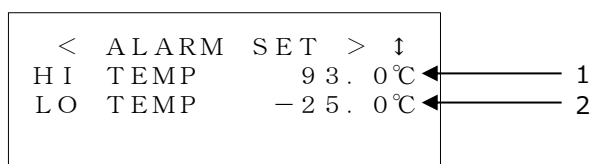

Fig.5-16 Alarm Setting Screen 1

Table 5-13 「Alarm Setting Screen 1」

No.	Item	Descriptions	Setting Range	Factory Default
1	HI TEMP	Allows the setting of temperature to generate "11:Reservoir High Temp. WRN". Alarm is raised when circulating fluid temperature exceeds the set value.	-20.0 to 95.0deg. C	93.0deg. C
2	LO TEMP	Allows the setting of temperature to generate "32:Reservoir Low Temp. WRN". Alarm is raised when circulating fluid temperature falls below the set value.	-25.0 to 90.0deg. C	-25.0deg. C

**[Tips]**

[▲] or [▼] key is used for selecting "Item" and move to other Alarm Setting screens.

And pressing the [ENT] key enabling to change the set value.

### 5.3.14 Alarm Setting Screen 2

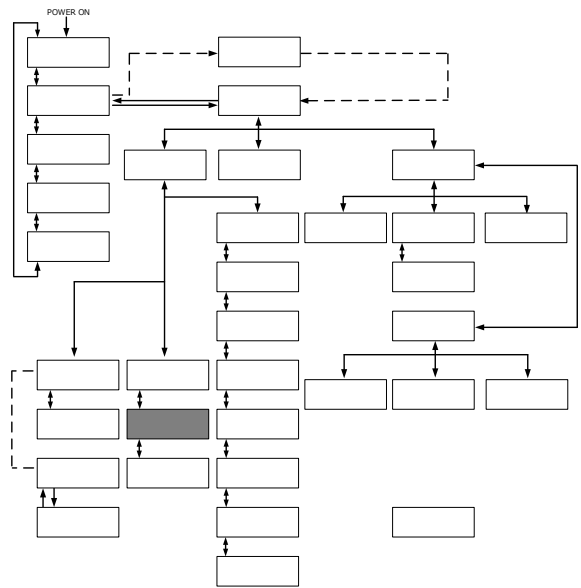
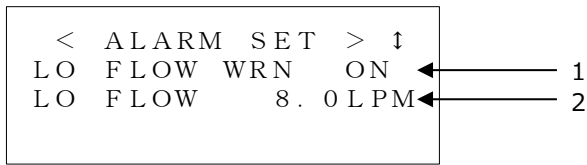

Fig.5-17 Alarm Setting Screen 2

Table 5-14 「Alarm Setting Screen 2」

No.	Item	Descriptions	Setting Range	Factory Default
1	LO FLOW WRN	Allows the setting of "13:Return Low Flow WRN" (valid:ON/invalid: OFF). Alarm is not raised if invalid:OFF is selected.	OFF, ON	ON
2	LO FLOW	Allows the setting of flow rate to generate "13:Return Low Flow WRN". Alarm is raised when circulating fluid flow rate falls below the set value.	8.0 to 40.0LPM	8.0LPM

**[Tips]**

[▲] or [▼] key is used for selecting "Item" and move to other Alarm Setting Screens. And pressing the [ENT] key enabling to change the set value.

### 5.3.15 Alarm Setting Screen 3

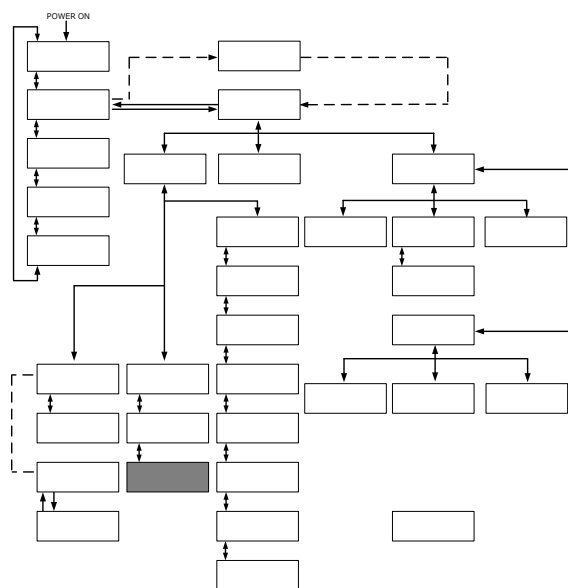
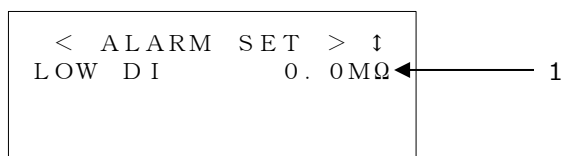

Fig.5-18 Alarm Setting Screen 3

Table 5-15 「Alarm Setting Screen 3」

No.	Item	Descriptions	Setting Range	Factory Default
1	LOW DI	Allows the setting of DI value to generate "24:DI Low Level WRN". Alarm is raised when DI value falls below the set value. Alarm is cancelled if the set value is 0.	0.0 to 2.0MΩ	0.0MΩ

#### [Tips]

It is displayed only if the DI Control Kit (optional) is provided.  
[▲] or [▼] key is used for selecting "Item" and move to other Alarm Setting screens. And pressing the [ENT] key enabling to change the set value.

### 5.3.16 Initial Setting Screen 1

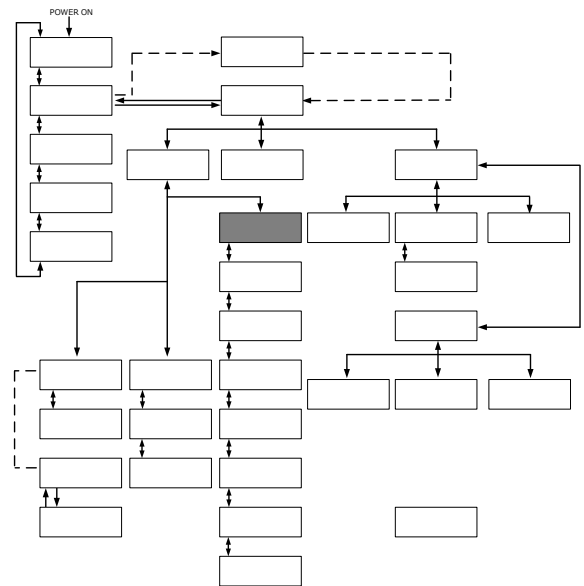
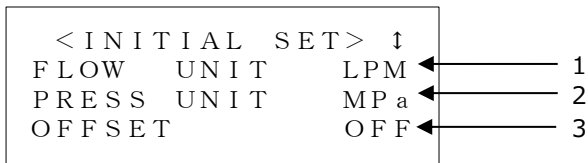

Fig.5-19 Initial Setting Screen 1

Table 5-16 [Initial Setting Screen 1]

No.	Item	Descriptions	Setting Range	Factory Default
1	FLOW UNIT	Displays Flow Rate unit.	- *1	LPM
2	PRESS UNIT	Displays Pressure unit	- *1	MPa
3	OFFSET	Allows the selection of Offset MODE.	MODE1 to 3、OFF	OFF

**[Tips]**

[▲] or [▼] key is used for selecting “Item” and move to other Initial Setting screens. And pressing the [ENT] key enabling to select the setting.

\*1 The unit setting cannot be changed.

### 5.3.17 Initial Setting Screen 2

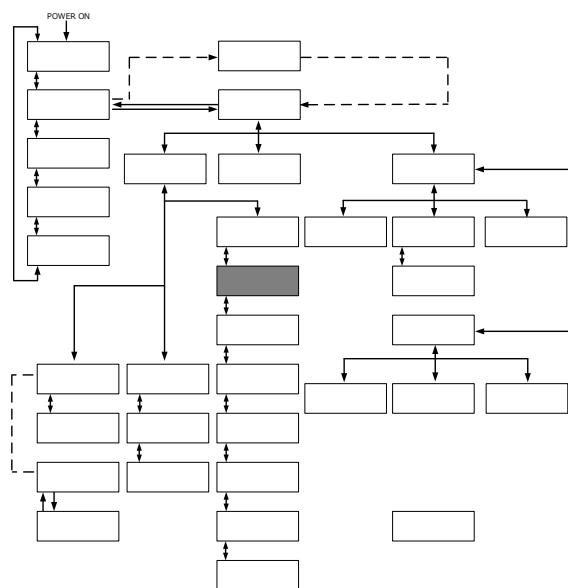
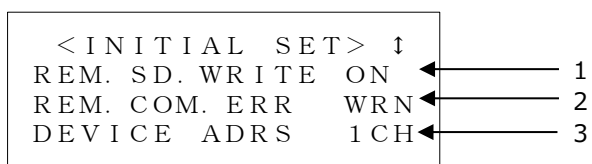

Fig.5-20 Initial Setting Screen 2

Table 5-17 「Initial Setting Screen 2」

No.	Item	Descriptions	Setting Range	Factory Default
1	REM.SD.WRITE	Store the TEMP SP and FLOW SP value with serial communication. TEMP SP and FLOW SP will be set to stored value after re-turn ON the main breaker.	OFF, ON	ON
2	REM.COM.ERR	Allows the selection of system condition when serial communication error occurs (WRN: Continued, FLT: Stop). If OFF is selected, no serial communication error will occur.	WRN, FLT, OFF	WRN
3	DEVICE ADRS	Allows the setting of the device address for serial communication.	1 to 32CH	1

**[Tips]**

[▲] or [▼] key is used for selecting “Item” and move to other Initial Setting Screens. And pressing the [ENT] key enabling to select the setting.

### 5.3.18 Initial Setting Screen 3

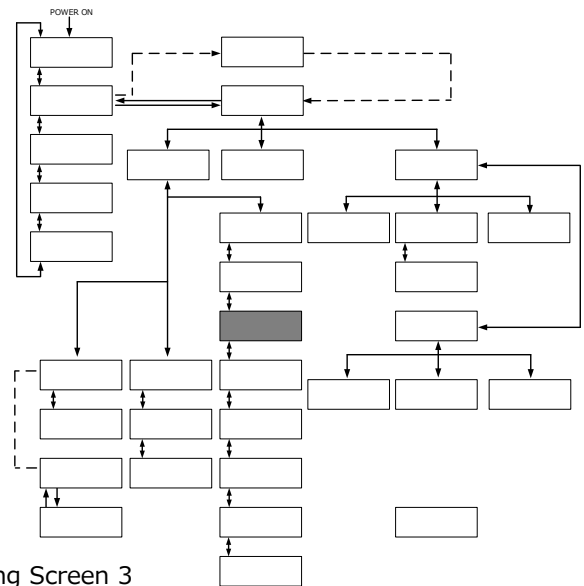
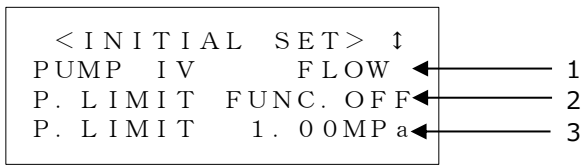

Fig. 5-21 Initial Setting Screen 3

Table 5-18 「Initial Setting Screen 3」

No.	Item	Descriptions	Setting Range	Factory Default
1	PUMP IV	Allows the selection of the controlled object for pump operation. FREQ : Pump frequency control. FLOW : Circulating fluid Flow rate control. PRESS : Pump discharge pressure control.	FREQ FLOW PRESS	FLOW
2	P. LIMIT FUNC.	Allows the setting of pump discharge pressure upper limit function (Valid : ON, Invalid : OFF).	OFF, ON	OFF
3	P. LIMIT	Allows the setting of pump discharge pressure upper limit value. This function enables the pump discharge pressure not to exceed the upper limit value to protect your system.	0.10 to 1.00MPa	1.00MPa

**[Tips]**

[▲] or [▼] key is used for selecting “Item” and move to other Initial Setting Screens. And pressing the [ENT] key enabling to select the setting.



### 5.3.19 Initial Setting Screen 4

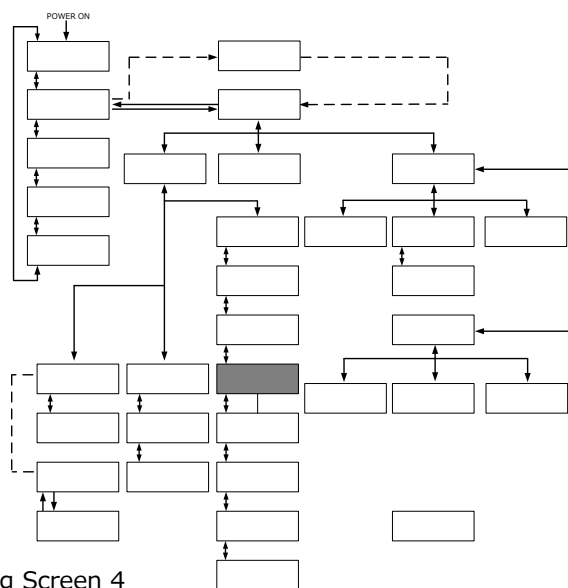

Fig.5-22 Initial Setting Screen 4

Table 5-19 [Initial Setting Screen 4]

No.	Item	Descriptions	Setting Range	Factory Default
1	PURGE STOP	Allows the selection of automatic collection stop mode. AUTO: Collection operation stops automatically when clection finished normally. TIME : Collection continues for the setting time.	AUTO TIME	AUTO
2	PURGE TIME	When "AUTO" mode, allows the setting for the time to raise "TIME OUT". When "TIME" mode, allows the setting of the time to continue collection operation.	1 to 600sec	300s

**[Tips]**

It is displayed only if the Circulating Fluid Automatic Collector (optional) is provided.

[▲] or [▼] key is used for selecting "Item" and move to other Initial Setting Screens. And pressing the [ENT] key enabling to select the setting.

### 5.3.20 Initial Setting Screen 5

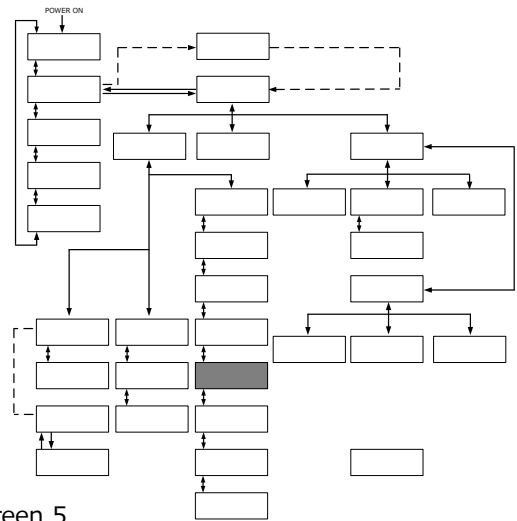
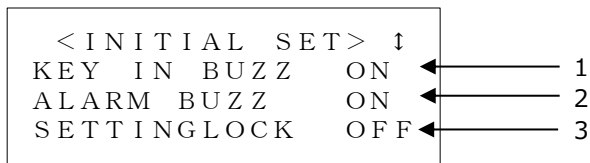

Fig.5-23 Initial Setting Screen 5  
Table 5-20 「Initial Setting Screen 5」

No.	Item	Descriptions	Setting Range	Factory Default
1	KEY IN BUZZ	Allows the setting of buzzer during key input (Valid : ON, Invalid : OFF).	OFF ON	ON
2	ALARM BUZZ	Allows the setting of alarm buzzer (Valid : ON, Invalid : OFF).	OFF ON	ON
3	SETTINGLOCK	<p>Allow the selection of "SETTINGLOCK" function. This function enables to restrict the input from operation display panel to prevent from unintended change of setting value from operaiton touch panel.</p> <ul style="list-style-type: none"> <li>·ALL : When communication mode is "LOCAL", only following operations are possible.                             <ul style="list-style-type: none"> <li>·START/STOP.</li> <li>·Setting of "SETTINGLOCK" function.</li> </ul> </li> <li>When communication mode is "DIO/SEREMOTE", only following operations are possible.                             <ul style="list-style-type: none"> <li>·Setting of "SETTINGLOCK" function.</li> </ul> </li> <li>·REM :  <ul style="list-style-type: none"> <li>·When communication mode is "LOCAL", normal operation is possible.</li> <li>·When communication mode is "DIO/SER REMOTE", only following operations are possible.                                     <ul style="list-style-type: none"> <li>·Setting of communication mode.</li> <li>·Setting of "SETTINGLOCK" function.</li> </ul> </li> </ul> </li> <li>·OFF : "SETTINGLOCK" function is invalid.</li> </ul>	OFF REM ALL	OFF

**[Tips]**

[▲] or [▼] key is used for selecting "Item" and move to other Initial Setting screens. And pressing the [ENT] key enabling to select the setting.

### 5.3.21 Initial Setting Screen 6

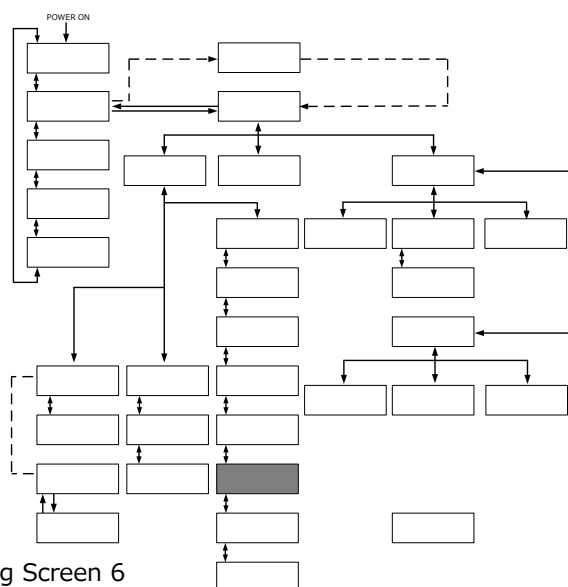
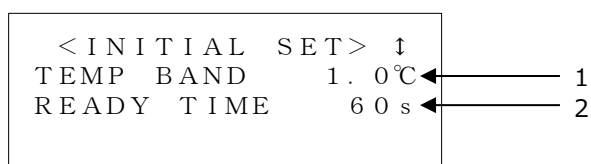

Fig.5-24 Initial Setting Screen 6

Table 5-21 [Initial Setting Screen 6]

No.	Item	Descriptions	Setting Range	Factory Default
1	TEMP BAND	Allows the setting of band range to TEMP PV.	1.0 to 99.9 deg C	1.0 deg. C
2	READY TIME	Allows the setting of time from when TEMP PV reaches the BAND range to when "TEMP READY" is displayed on operation display panel and Ready signal is output.	1 to 999s	60s

**[Tips]**

See "8.5 BAND/READY" on page 8-16.

[▲] or [▼] key is used for selecting "Item" and move to other Initial Setting screens. And pressing the [ENT] key enabling to select the setting.

### 5.3.22 Initial Setting Screen 7

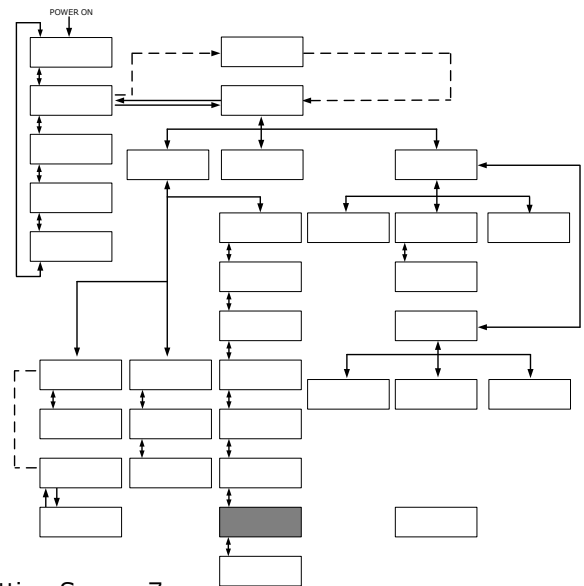
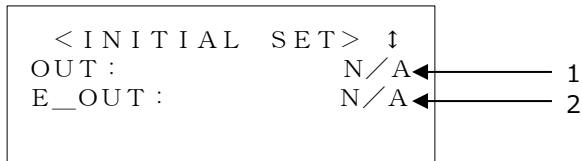

Fig. 5-25 Initial Setting Screen 7

Table 5-22 「Initial Setting Screen 7」

No.	Item	Descriptions	Setting Range	Factory Default
1	OUT	Allows the selection of alarm signals for contact signal. (See "8.1.7 Alarm Signal Selection" (page 8-10) for details.)	N/A ALARM01 to 32	N/A
2	E_OUT	Allows the selection either TEMP READY or AUTO PURGE signal.(Output for pin No. 8 of "8.1.6 Communication Specifications" (page 8-7). See communication specification for details.	N/A TEMP READY*1 AUTO PURGE	N/A

**[Tips]**

See "8.5 BAND/READY"(page 8-16) for TEMP BAND, READY TIME (\*1).

[▲] or [▼] key is used for selecting "Item" and move to other Initial Setting Screens. And pressing the [ENT] key enabling to select the setting or set value.

### 5.3.23 Initial Setting Screen 8

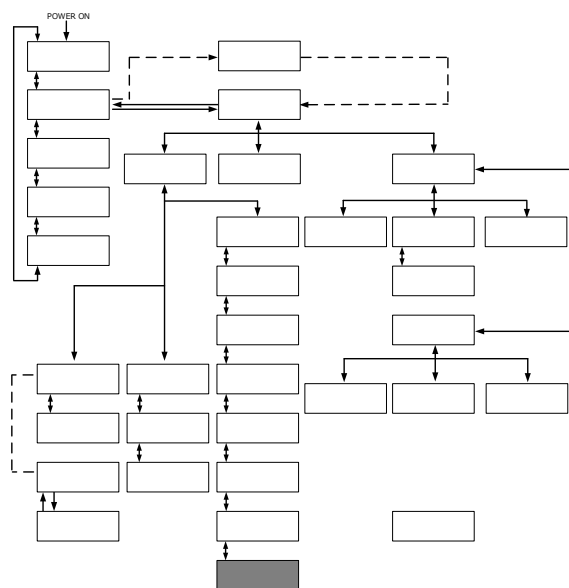

Fig. 5-26 Initial Setting Screen 8

Table 5-23 「Initial Setting Screen 8」

No.	Item	Descriptions	Setting Range	Factory Default
1	CUSTOM DIO	Allows the setting for DIO signal customize (valid:ON/invalid:OFF). See "Communication Specifications" for details.	OFF, ON	OFF

#### [Tips]

[▲] or [▼] key is used for selecting "Item" and move to other Initial Setting Screens. And pressing the [ENT] key enabling to select the setting or set value.

### 5.3.24 Mode Selection Screen

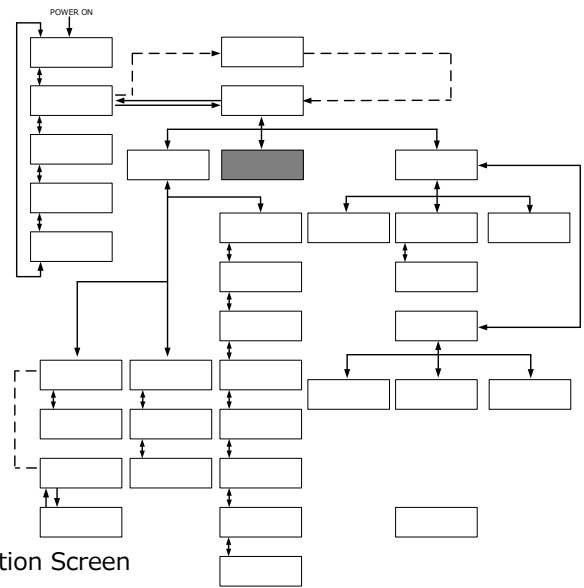

Fig. 5-27 Mode Selection Screen

Table 5-24 「Mode Selection Screen」

No.	Item	Descriptions	Setting Range	Factory Default
1	MODE	<p>Allows the selection of communication mode.</p> <p>LOCAL : System start/stop and TEMP SP value setting are available only from the operation display panel.</p> <p>DIO REMOTE : System start/stop is allowed only through contact signal. When Analog Communication option is provided, TEMP SP value setting is available through analog signal.</p> <p>SER REMOTE : System start/stop and TEMP SP value setting are available only through serial RS-485 communication.</p> <p>DNET REMOTE<sup>*1</sup> : System start/stop and TEMP SP value setting are available only through Device Net communication.</p>	<p>LOCAL</p> <p>DIO REMOTE</p> <p>SER REMOTE</p> <p>DNET REMOTE<sup>*1</sup></p>	LOCAL

**[Tips]**

It is displayed only if the Device Net Communication (optional) is provided (\*1).

[▲] or [▼] key is used for selecting “Item” And pressing the [ENT] key enabling to select the setting.

### 5.3.25 Maintenance Screen 1

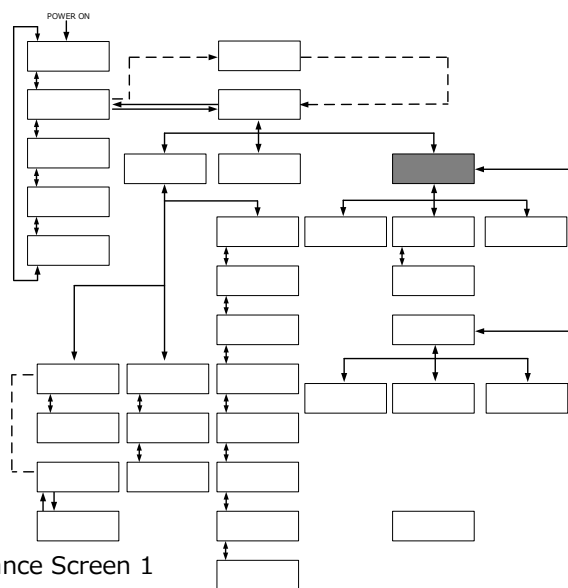

Fig. 5-28 Maintenance Screen 1

Table 5-25 「Maintenance Screen 1」

No.	Item	Descriptions
1	VALVE OPEN	Switches to the "Maintenance Item Screen 3" with the press of the [ENT] key.
2	ALARM HISTORY	Switches to the "Maintenance Item Screen 4" with the press of the [ENT] key.
3	RUNNING DATA	Switches to the "Maintenance Item Screen 5" with the press of the [ENT] key.

**[Tips]**

[▲] or [▼] key is used for selecting "Item" and move to other Maintenance screens. And pressing the [ENT] key enabling to change the setting or set value.

### 5.3.26 Maintenance Screen 2

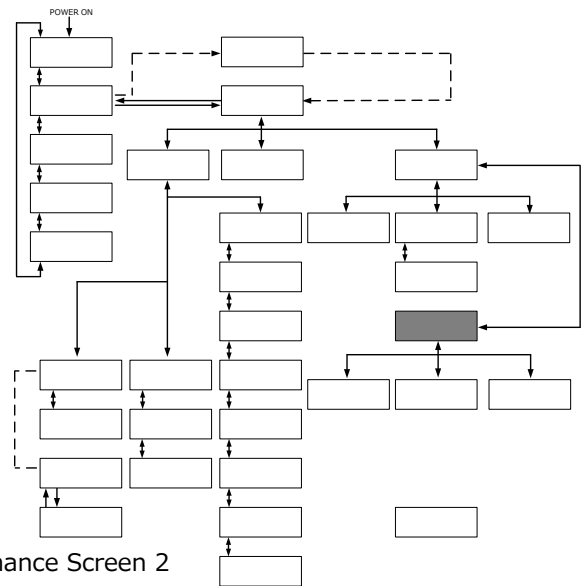

Fig. 5-29 Maintenance Screen 2

Table 5-26 「Maintenance Screen 2」

No.	Item	Descriptions
1	MONITOR	Switches to the "Maintenance Item Screen 6" with the press of the [ENT] key.
2	AUTO PURGE* <sup>1</sup>	Switches to the "Maintenance Item Screen 7" with the press of the [ENT] key.
3	DI ACC RESET* <sup>2</sup>	Switches to the "Maintenance Item Screen 8" with the press of the [ENT] key.

**[Tips]**

It is displayed only if the Circulating Fluid Automatic Collector (optional) is provided (\*1).

It is displayed only if the DI Control Kit (optional) is provided (\*2).

[▲] or [▼] key is used for selecting "Item." and move to other Maintenance screens. And pressing the [ENT] key enabling to change the setting or set value.



### 5.3.27 Maintenance Screen 3

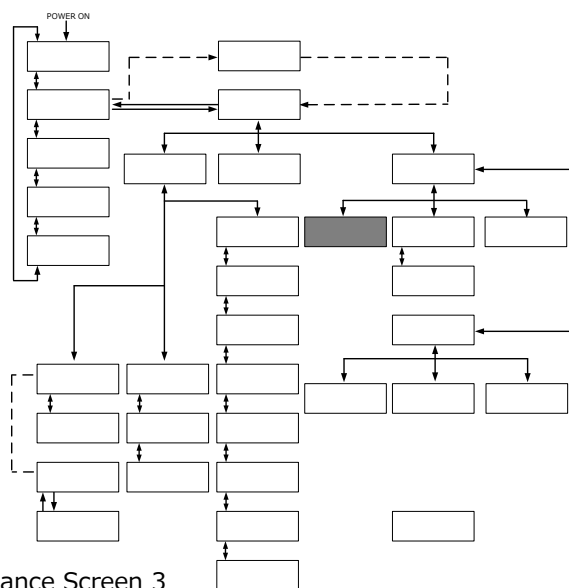
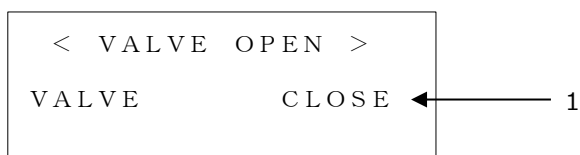

Fig. 5-30 Maintenance Screen 3

Table 5-27 [Maintenance Screen 3]

No.	Item	Setting Range	Descriptions
1	VALVE	OPEN	The solenoid valve for DI circuit is opened forcefully.
		CLOSE	The solenoid valve for DI circuit is closed forcefully.

**[Tips]**

It is displayed only if the DI Control Kit (optional) is provided.  
 For other options, "N/A" is displayed on the screen.  
 If you move the screen from "Maintenance Screen 3",  
 The forced operation of the solenoid valve will be canceled.

### 5.3.28 Maintenance Screen 4

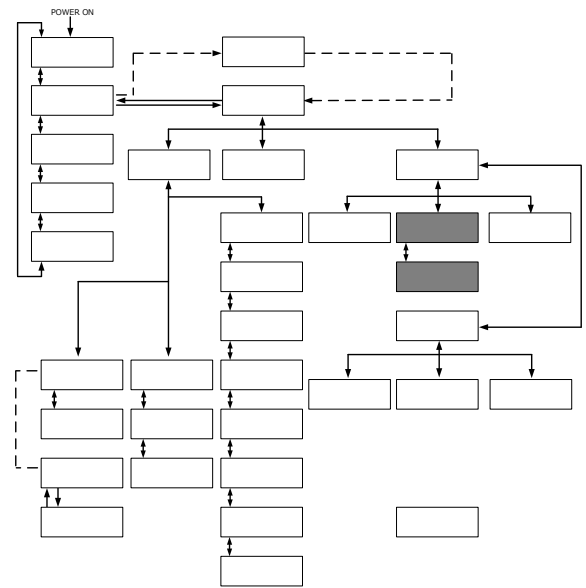
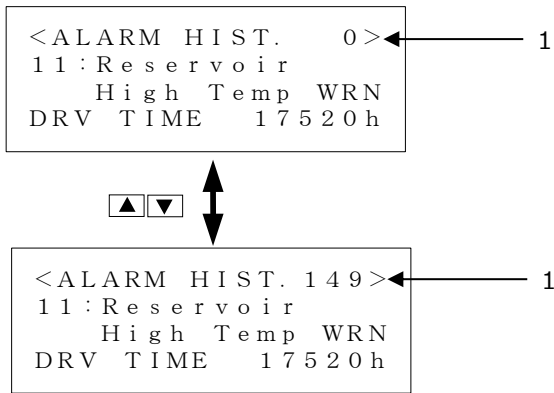

Fig. 5-31 Maintenance Screen 4

Table 5-28 「Maintenance Screen 4」

No.	Item	Descriptions
1	ALARM HIST	Data recording stores up to 150 pieces of alarm history data. If there are 150 or more pieces of data, the alarm history data is to be deleted in order of longest stores.

### 5.3.29 Maintenance Screen 5

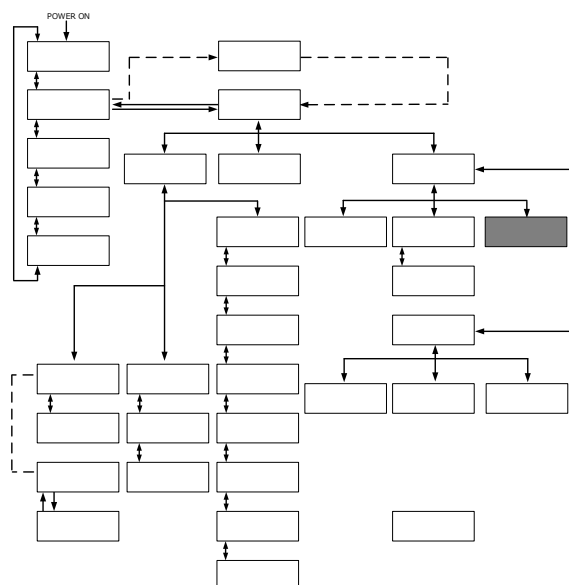
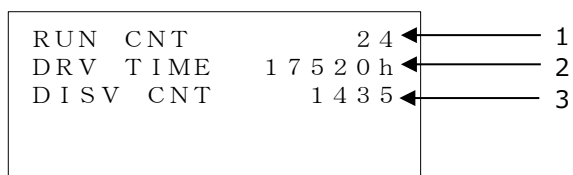

Fig. 5-32 Maintenance Screen 5

Table 5-29 「Maintenance Screen 5」

No.	Item	Descriptions
1	RUN CNT	Number of times of operation on the system.
2	DRV TIME	Operating time on the system.
3	DISV CNT <sup>※1</sup>	Number of times that the solenoid valve for DI circuit is activated.

**[Tips]**

It is displayed only if the DI Control Kit (optional) is provided. (\*1)  
 For other options, "N/A" is displayed on the screen.

### 5.3.30 Maintenance Screen 6

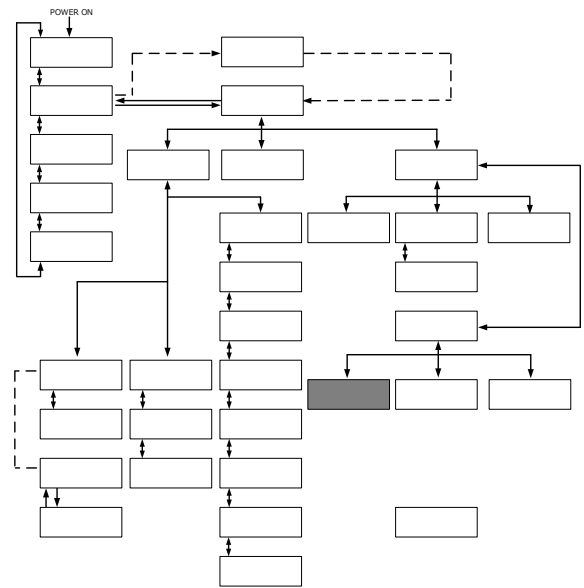
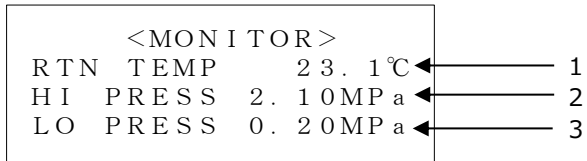

Fig. 5-33 Maintenance Screen 6

Table 5-30 「Maintenance Screen 6」

No.	Item	Descriptions
1	RTN TEMP	Return temperature of circulating fluid.
2	HI PRESS	High pressure of refrigerant circuit.
3	LOW PRESS	Low pressure of refrigerant circuit.

### 5.3.31 Maintenance Screen 7

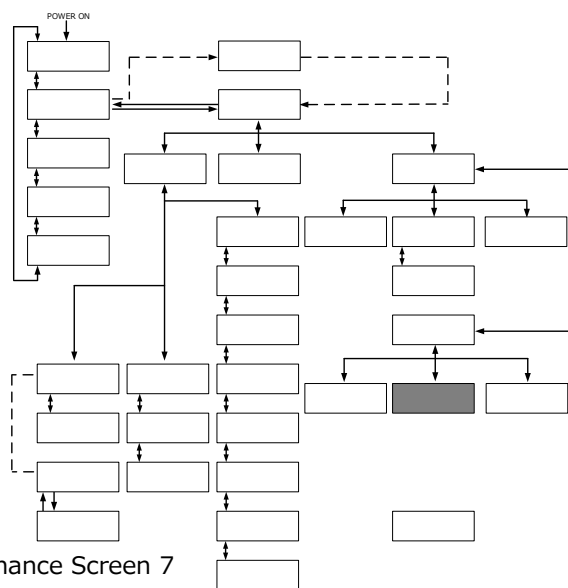
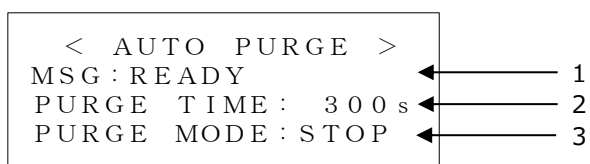

Fig. 5-34 Maintenance Screen 7

Table 5-31 「Maintenance Screen 7」

No.	Item	Descriptions
1	MSG	Indicates the status of circulating fluid automatic collection. READY : Ready to collect. PURGE START : During collection. FINISH : Collection finished normally. TIME OUT : Collecting time exceeds setting value. IN RUNNING : This system during operation. ALARM : Alarm raised to this system. TEMP OUT : Circulating fluid temp. is out of range for starting collection.
2	PURGE TIME	Setting value of PURGE TIME.
3	PURGE MODE	Start/Stop circulating fluid automatic collection. After pressing [ENT] key, pressing either [▲] or [▼] key to select Start/Stop. Then automatic collection Start/Stop is available after pressing [ENT] key to fix the setting. START : Start collection. STOP : Stop collection.

**[Tips]**

It is displayed only if the Circulating Fluid Automatic Collector (optional) is provided.  
 When MSG is "READY", Start/Stop of circulating fluid automatic collection is available.

### 5.3.32 Maintenance Screen 8

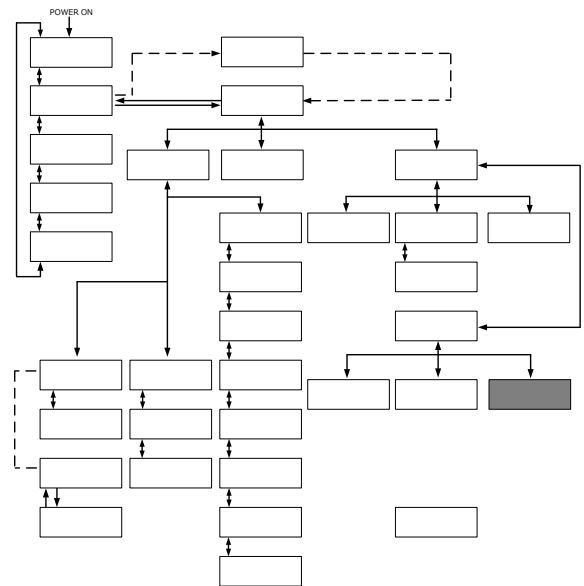
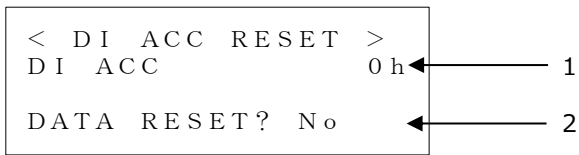

Fig. 5-35 Maintenance Screen 8

Table 5-32 「Maintenance Screen 8」

No.	Item	Descriptions
1	DI ACC	Accumulated time that the solenoid valve for DI circuit is activated.
2	DATA RESET?	Allows to reset DI ACC. After pressing [ENT] key, pressing either [▲] or [▼] key to select Yes/No. Then Reset/Not reset DI ACC after pressing [ENT] key to fix the setting. Yes : Reset DI ACC. No : Not reset DI ACC.

**[Tips]**

It is displayed only if the DI Control Kit (optional) is provided.

### 5.3.33 System Information Screen

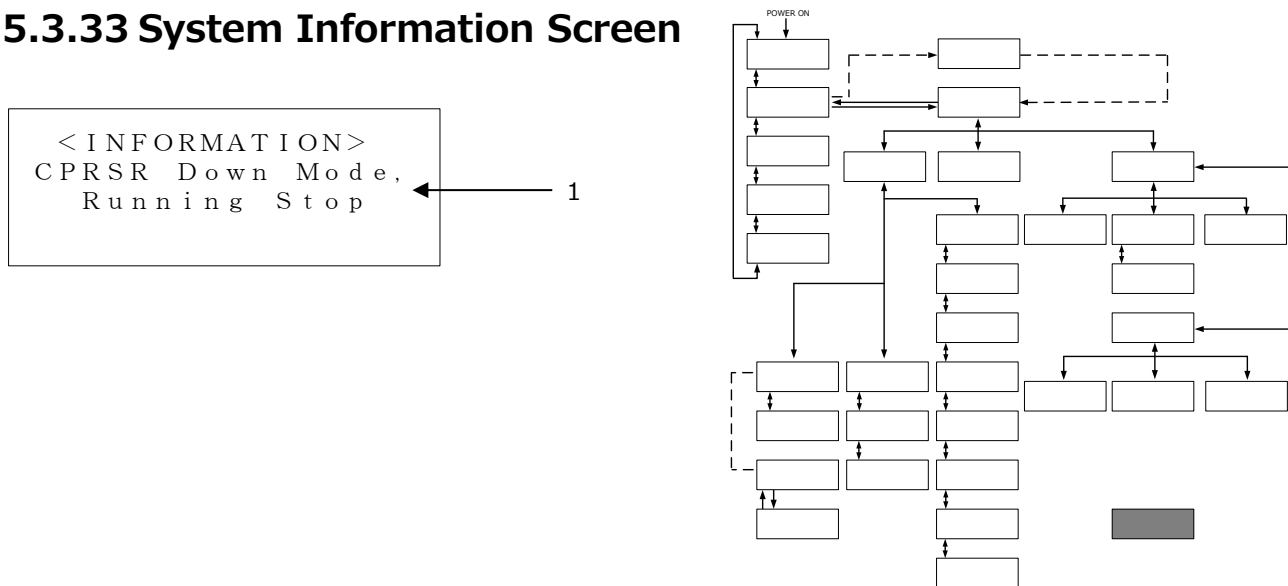

Fig. 5-36 System Information Screen

The "System Information Screen", as shown above, may be displayed upon system Start/Stop.

Table 5-33 「System Information Screen」

No.	Item	Descriptions
1	INITIALIZE MODE (CONTROL VALVE) (RESERVOIR)	Operation preparation mode after turn-On the main breaker. System operation is disabled if this message is displayed. CONTROL VALVE : Positioning of the electronic expansion valve is performed. RESERVOIR : The circulating fluid flows in this system through the internal pump.
	Pump Up Mode Running Start	If your piping is supplied with an insufficient amount of the circulating fluid at system startup, the circulating pump in this system activated (repeating ON/OFF) to replenish piping with the circulating fluid. Continuous operation is initiated once piping is replenished with the fluid.
	CPRSR Down Mode. Running Stop	Compressor operation remains for approx. 20 seconds after circulating pump stop for the protection of the compressor at the time of system shutdown.

## 5.4 Examples of System Operation

### 5.4.1 Example 1: Circulating fluid set temperature is changed from 20.0 deg. C to 34.1 deg. C.

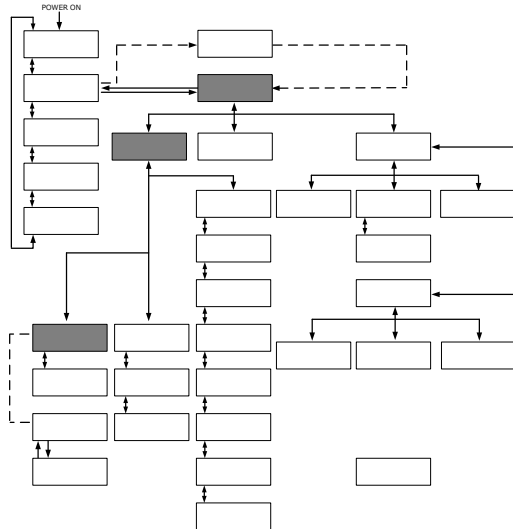

Fig. 5-37 Circulating Fluid Set Temperature

**1** Press the [SEL] key to display the “Menu screen”.

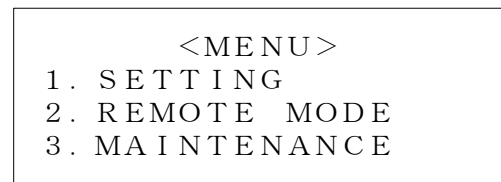

Fig. 5-38 [Menu Screen]

**2** With the use of the arrow keys ([▲], [▼]), move the cursor to “1. SETTING” and press the [ENT] key.

The “Setting Screen” is displayed.



Fig. 5-39 [Setting Screen]

**3** With the use of the arrow keys ([▲], [▼]), move the cursor to “1. CONTROL SET” and press the [ENT] key

The “Control Setting Screen 1” is displayed.

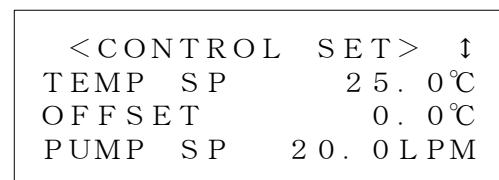

Fig. 5-40 [Control Setting Screen 1]



#### 4 Press the [ENT] key

The cursor is now appeared on the current value for TEMP SP, which enables change of the temperature set value.

```

<CONTROL SET>  ↑
TEMP SP      2  █. 0°C
OFFSET      0. 0°C
PUMP SP     20. 0 LPM
  
```

Fig. 5-41 Cursor Displayed

#### 5 Use the arrow keys ([▲], [▼], [ ]) to change the temperature to 34.1 deg. C.

[▲] key: Used to add one value on which the cursor is placed.

[▼] key: Used to subtract one value on which the cursor is placed.

[▶] key: Used to move the cursor to the right.

```

<CONTROL SET>  ↑
TEMP SP      3 4. █°C
OFFSET      0. 0°C
PUMP SP     20. 0 LPM
  
```

Fig. 5-42 Change of Set Value

#### 6 Press the [ENT] key after changes

The cursor disappears and the set value is fixed at 34.1°C.

```

<CONTROL SET>  ↑
TEMP SP      3 4. 1°C
OFFSET      0. 0°C
PUMP SP     20. 0 LPM
  
```

Fig. 5-43 Setting Confirmation

### 5.4.2 Example 2: Communication mode is switched from "LOCAL" to "SER REMOTE".

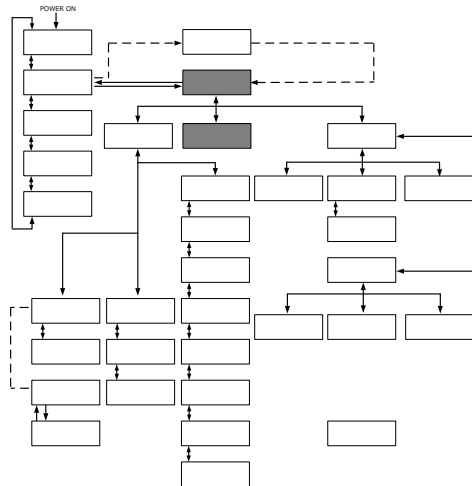

Fig. 5-44 Setting of Communication Mode

**1** [Press the [SEL] key to display the "Menu screen"

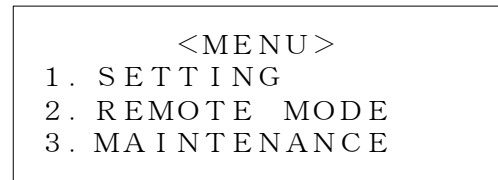

Fig. 5-45 Menu Screen

**2** With the use of the arrow keys ([▲], [▼]), move the cursor to "2. REMOTE MODE" and press the [ENT] key.

The "Mode Selection Screen" is displayed.



Fig. 5-46 Setting of Communication Mode

**3** Press the [ENT] key

The name of current mode "LOCAL" flashes and enable to switch the setting.

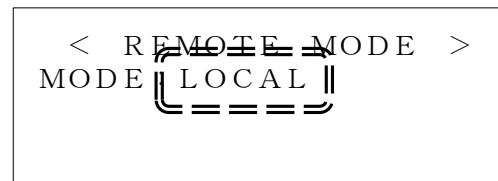

Fig. 5-47 Mode Selection Screen

**4** Use the arrow keys ([▲], [▼]), to select "SER REMOTE".

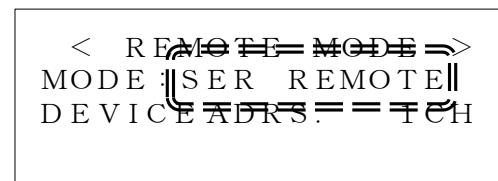

Fig. 5-48 Set to SER REMOTE

**5** Press the [ENT] key

### 5.4.3 Example 3: PUMP IV is switched from "FLOW" to "FREQ".

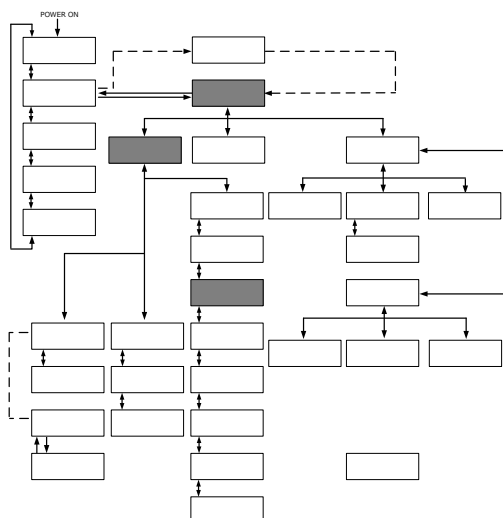

Fig. 5-49 PUMP IV Switched

#### 1 Press the [SEL] key to display the "Menu Screen"

```

<MENU>
1. SETTING
2. REMOTE MODE
3. MAINTENANCE
  
```

Fig. 5-50 [Menu Screen]

#### 2 With the use of the arrow keys ([▲], [▼]), move the cursor to "1.SETTING" and press the [ENT] key.

The "Setting Screen" is displayed.

```

<SETTING>
1. CONTROL SET
2. ALARM SET
3. INITIAL SET
  
```

Fig. 5-51 [Setting Screen]

#### 3 With the use of the arrow keys([▲], [▼]),move the cursor to "3.INITIAL SET" and press the [ENT] key.

The [Initial Setting Screen 1] is displayed.

```

<INITIAL SET> ↑
FLOW UNIT LPM
PRESS UNIT MP a
OFFSET OFF
  
```

Fig. 5-52 [Initial Setting Screen 1]

- 4** With the use of the arrow keys([▲],[▼]),  
Move the cursor to “Initial Setting screen 3”

```

< I N I T I A L   S E T > ↑
P U M P   I V           F L O W
P . L I M I T   F U N C . O F F
P . L I M I T       1 . 0 0 M P a
    
```

Fig. 5-53 「Initial Setting Screen3」

- 5** With the use of the arrow keys([▲],[▼]), move the cursor to “PUMP IV” and press the [ENT]key.

The name of current setting “FLOW” flashes and enable to switch the setting.

```

< I N I T I A L   S E T > ← →
P U M P   I V           F L O W
P . L I M I T   F U N C . O F F
P . L I M I T       1 . 0 0 M P a
    
```

Fig. 5-54 「Initial Setting Screen3」

- 6** With the use of the arrow keys([▲],[▼])  
to select “FREQ”.

```

< I N I T I A L   S E T > ← →
P U M P   I V           F R E Q
P . L I M I T   F U N C . O F F
P . L I M I T       1 . 0 0 M P a
    
```

Fig. 5-55 「Initial Setting Screen3」

- 7** Press the [ENT] key

# Chapter 6 Error Message and Troubleshooting

## 6.1 Error Message

The following are to be performed in the event of an error in this system.

- The "ALARM" lamp comes on.
- Alarm buzzer comes on.
- The "Alarm Display screen" is displayed on the LCD screen.
- Error signal is issued through external communication. See "8.1.6 Communication Specifications" on page 8-7 for details.
- This system is brought to a stop forcefully according to error types.

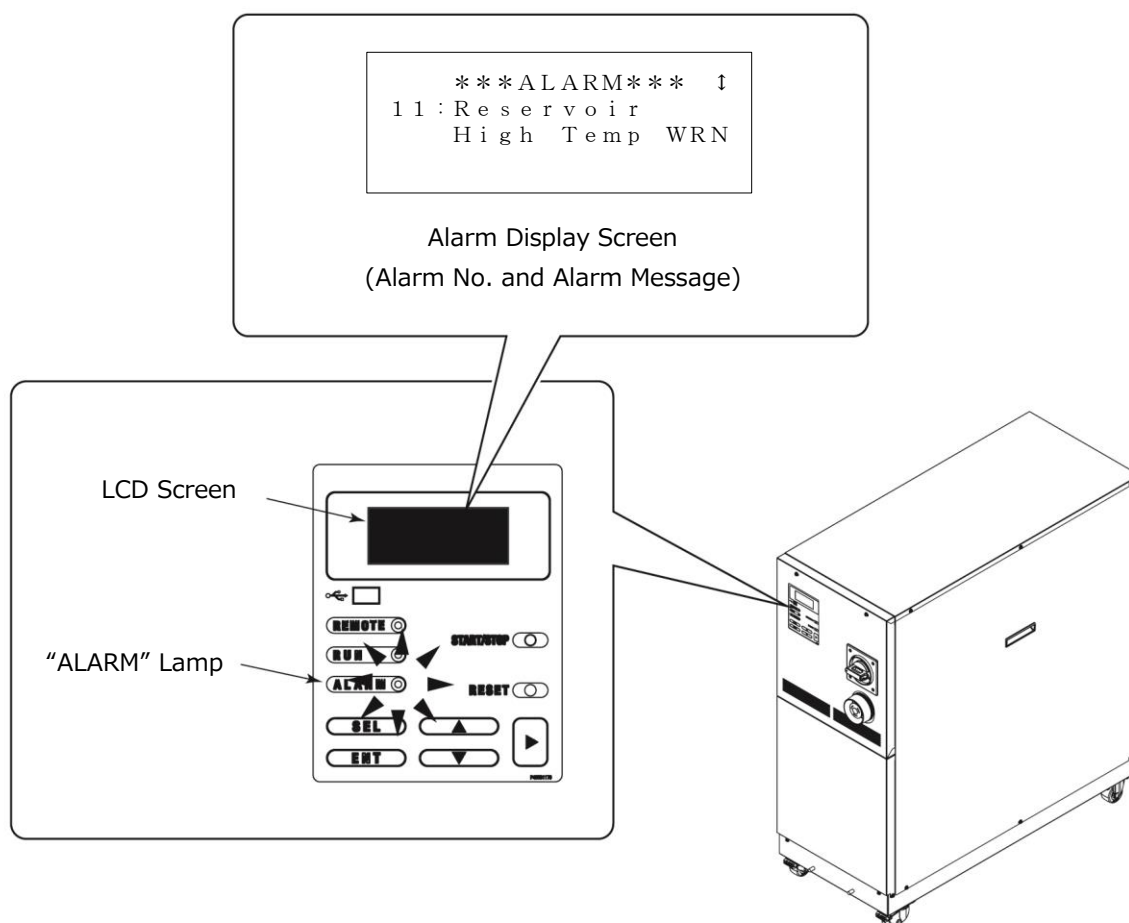

Fig. 6-1 Error Occurrence

## 6.2 Troubleshooting

The procedure for error recovery varies with alarm types.

- Alarm No. 01 to 21,24,25,28,29,32 :

Eliminate the error cause. Press the [RESET] key on the operation display panel or power cycle the main breaker to enable error recovery to take effect.

- Alarm No. 22 :

Eliminate the error cause, and power cycle the main breaker to enable error recovery to take effect.

- Alarm No. 23 :

Automatic error recovery is implemented upon elimination of the error.

- Alarm No. 24 :

This is an alarm for accessories (optional).

No alarm of this type is issued if the system is outfitted with no accessories.

Table 6-1 Troubleshooting (1/3)

Alarm No.	Error message	System condition	Cause	Remedies
01	Water Leak Detect FLT	Stop	The fluid is pooled at the base of this system.	Check for fluid leak.
03	RFGT High Press FLT	Stop	The pressure of the refrigerant circuit exceeded the specified value (2.5MPa).	Check that facility water is being supplied to this system.
04	CPRSR Overheat FLT	Stop	The temperature in the compressor was excessive (110 deg. C).	Check that facility water is being supplied to this system.
05	Reservoir Low Level FLT	Stop	An insufficient amount of the circulating fluid is observed in the tank.	Replenish the circulating fluid.
06	Reservoir Low Level WRN	Continued	An insufficient amount of the circulating fluid is observed in the tank.	Replenish the circulating fluid.
07	Reservoir High Level WRN	Continued	An excessive amount of the circulating fluid is observed in the tank.	Drain the circulating fluid.
08	Temp. Fuse Cutout FLT	Stop	The circulating fluid tank was raised in temperature. Thermal fuse cutout temperature : 98 deg. C	Check the load specification. Replacement of the thermal fuse is required. Call the supplier for service.
09	Reservoir High Temp. FLT	Stop	The temperature of the circulating fluid exceeded the specified value <Specified value> : 95 deg.C).	Check the load specification.
10	Return High Temp WRN	Continued	The temperature of the circulating fluid exceeded the specified value . <Specified value> : HRZF010-WS : 110 deg. C HRZF010-W1S:100 deg. C	Check the circulating fluid flow rate, load specification.

Table 6-1 Troubleshooting (2/3)

Alarm No.	Error message	System condition	Cause	Remedies	
11	Reservoir High Temp. WRN	Continued	The temperature of the circulating fluid exceeded your set value. <Setting range> : -20.0 to 95.0 deg. C <Factory default> : 93.0 deg. C	Reset the setting temperature.	
12	Return Low Flow FLT	Stop	The flow rate of the circulating fluid falls below specified value. <Specified value> : 6L/min	<ul style="list-style-type: none"> <li>Check that the external valve is opened.</li> <li>Prepare a thicker external pipe or install bypass piping.</li> </ul>	
13	Return Low Flow WRN	Continued	The flow rate of the circulating fluid falls below your set value. <Specified value> : 8.0 to 40.0L/min (2.1 to 10.6GPM) <Factory default> : 8.0L/min (2.1GPM)	Reset the setting flow rate.	
19	FAN Motor Stop WRN	Continued	The ventilating fan came to a stop.	Check that the air vent on the back of the system is not blocked off.	
20	Internal Pump Time Out WRN	Continued	The internal pump was under conditions of continuous operation over a specified time. <Specified time> : 10min	Check for fluid leak from circulating fluid piping in your system.	
21	Controller Error FLT	Stop	An error was detected in the control system. See below Table 6-2.	Contact the system supplier for request of inspection and repair.	
22	Memory Data Error FLT	Stop	An error was detected in data stored in the controller of this system.	<ul style="list-style-type: none"> <li>Re-turn ON the main breaker to recover from the error.</li> <li>Contact the system supplier for request of inspection and repair.</li> </ul>	
23	Communication Error	CODE 0001	Continued	An interruption of serial communication occurred in this system.	Contact the system supplier for request of inspection and repair.
		CODE 8000	Continued	An interruption of serial communication occurred between this system and your system.	Check for disconnection of the communication connector from this system.
24	DI Low Level WRN	Continued	The DI level of the re-circulating liquid lowered than the your set value (Optional). <Setting range> : 0.0 to 2.0MΩ <Factory default> : 0.0MΩ	<ul style="list-style-type: none"> <li>Lower the setting for resistivity.</li> <li>Replacement of the DI filter is required</li> </ul>	

Table 6-1 Troubleshooting (3/3)

Alarm No.	Error message	System condition	Cause	Remedies
25	Pump Inverter Error FLT	Stop	An error was detected in the inverter for circulating pump.	Contact the system supplier for request of inspection and repair.
28	CPRSR INV Error FLT	Stop	An error was detected in the inverter for compressor.	Contact the system supplier for request of inspection and repair.
29	RFGT Low Press FLT	Stop	The refrigerant pressure falls below the specified value. <Specified value> : 0.1MPa	Contact the system supplier for request of inspection and repair.
32	Reservoir Low Temp. WRN	Continued	The temperature of the circulating fluid falls your set value. <Setting range> : -25.0 to 90.0 deg. C <Factory default> : -25.0 deg. C	Reset the setting temperature.

Table 6-2 Alarm 21 CODE Lists

Alarm No.	Error message	CODE	System condition	Cause	Remedies
21	Controller Error FLT	0001	Stop	Internal board communication error.	Contact the system supplier for request of inspection and repair.
		0002		Discharge temperature sensor error.	
		0004		Internal temperature sensor error.	
		0008		Return temperature sensor error.	
		0020		Internal temperature sensor error.	
		0040		Internal temperature sensor error.	
		0200		Circulating liquid pressure sensor error.	
		0800		Refrigeration circuit pressure sensor error.	
		1000		Refrigeration circuit pressure sensor error.	
		2000		Pump inverter communication error.	
		4000		Compressor inverter communication error.	
		6000		Inverter communication error.	



# Chapter 7 System Maintenance

## 7.1 Water Quality Management

### ⚠ CAUTION



Only designated circulating fluid is permitted to use for this system. Potential system failure and fluid leak may occur if disregarded, which results in electric shock, ground fault, and freeze.

Be sure to use fresh water (tap water) compliant with water quality standards in the table below for ethylene glycol aqueous solution and facility water.

Table 7-1 Water Quality Standards for Fresh Water (Tap Water)

	Substance	Facility water spec.	Circulating water spec.
Standards *Circulating fluid 1 to 500 (mgCaCO <sub>3</sub> /L)	pH (25 deg. C)	6.5 to 8.2	6.0 to 8.0
	Electrical conductivity (25 deg. C) (μs/cm) *Circulating fluid 1 to 500	100 to 800	0.5 to 300
	Chloride ion (mgCl <sup>-</sup> /L)	Max. 200	Max.50
	Sulfate ion (mgSO <sub>4</sub> <sup>2-</sup> /L)	Max.200	Max.50
	Acid consumption (pH4.8) (mgCaCO <sub>3</sub> /L)		
	Total hardness (mgCaCO <sub>3</sub> /L)	Max.200	Max.70
	Calcium hardness (mgCaCO <sub>3</sub> /L)	Max.150	Max.50
	Ionic silica (mgSiO <sub>2</sub> /L)	Max.50	Max.30
	Iron (mgFe/L)	Max.1.0	Max.0.3
	Copper (mgCu/L)	Max.0.3	Max.0.1
	Sulfide ion (mgS <sup>2-</sup> /L)	Not be detected	
	Ammonium ion (mgNH <sub>4</sub> <sup>+</sup> /L)	Max.1.0	Max.0.1
	Residual chlorine (mgCl/L)	Max.0.3	Max.0.3
	Free carbon dioxide (mgCO <sub>2</sub> /L)	Max.4.0	Max.4.0
	Filtering (μm)	Max.5	

\* According to the Water quality guideline for refrigeration air-conditioning equipment: JRA-GL-02-1994

### ⚠ CAUTION



If the periodic inspection finds a nonconforming substance in the facility water, clean the facility water circuit and recheck the quality of the facility water.

## 7.2 Inspection and Cleaning

### **WARNING**



Do not touch any electrical parts with wet hands. Keep wet hands away from electrical parts. Potential electric shock can occur if disregarded. Keep this system from water. Potential electric shock or fire can occur if disregarded.

### **WARNING**



If the inspection and cleaning require the removal of the panel, be sure to re-attach the panel upon completion. Potential personal injury or electric shock may occur if operated with the panel opened or removed.

### 7.2.1 Daily Inspection

Table 7-2 Daily Inspection

Inspection Item	Inspection method	
Installation Condition	Check of the condition of system installation	No heavy object is placed on this system. This system should not be subjected to external force.
		Temperature and humidity fall within the specified range.
Fluid Leak	Check of the piping connector section	No leak of facility water and circulating fluid from the piping connector section
Fluid Level	Reading of the level of the circulating fluid	Level falls within the circulating fluid specified level between "High" and "Low".
Operation Display Panel	Display check	Clarity of letters and numbers on the LCD display should be assured.
	Function check	[RUN] lamp is ON.
Circulating Fluid Temperature	Confirm the reading on the LCD screen	Temperature should be within setpoint.
Refrigerant Pressure	Reading of the refrigerant pressure gauge	Value of "HI PRESS" in "5.3.30 Maintenance Screen 6 (page 5-32) " should be in the following range.
Discharge Pressure of Circulating Fluid	Confirm the reading on the LCD screen	Reading should not have deviated much from last inspection.
Circulating Fluid Flow Rate	Confirm the reading on the LCD screen	Reading should not have deviated much from last inspection.
Operating Condition	Operating condition check	No abnormal noise, vibration, odor and smoke
Facility Water	Check of the facility water	Temperature, flow rate and pressure fall within the specified range.
Circulating Fluid Supply Port Cap	Check by providing manual tightening	No looseness

## 7.2.2 Quarterly Inspection

### WARNING



Quarterly inspection requires an advance lockout/tagout of this system. See "1.6.3 Lockout/Tagout" for details on page 1-15.

Table 7-3 Quarterly Inspection

Inspection Item	Inspection Method
Circulating Fluid	Circulating fluid is to be drained for check. Fluid should be free of particles, moisture <sup>*1</sup> and foreign substances.
	For ethylene glycol aqueous solution, confirm that the concentration falls within the specified range.
Facility Water	Facility water quality should fall within the standards specified.
Ventilation Hole and Electrical Parts	No particles and dust should be present.

### CAUTION



Moisture trapped in the fluorinated fluid (\*1) freezes in the heat exchanger element and piping, which may lead to system failure.

## 7.3 Storage

The following should be performed for system long-term storage.

- 1** Drain the circulating fluid. See "7.3.1 Draining of Circulating Fluid Out of Tank" for details on page 7-4.
- 2** Drain the facility water. See "7.3.2 Draining of Facility Water" for details on page 7-5.
- 3** Cover the system with a plastic sheet for storage.

### 7.3.1 Draining of Circulating Fluid Out of Tank

**⚠ CAUTION**

 Use the clean container for circulating fluid recovery. Reuse of the recovered circulating fluid with contaminated will cause insufficient cooling and system failure.  
Be sure to wait until the circulating fluid obtains room temperature for its draining. Potential burns and dew intrusion may occur if disregarded.

**1** Prepare the container for circulating fluid recovery at the back of this system.

**2** Connect the drain hoses to the main and sub tank drain ports each. Insert the tip of the hose into the container.

Prepare a drain hose (Rc3/8-diameter) on your responsibility.

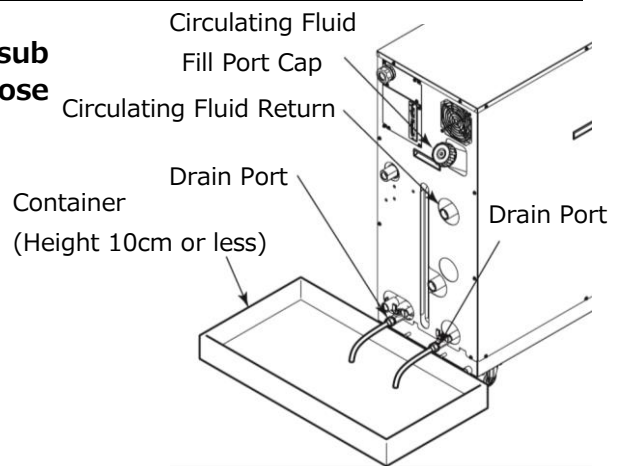



Fig. 7-1 Container for Circulating Fluid Recovery

**3** Remove the cap of the circulating fluid fill port

**4** Open the valves of the main and sub tank drain ports to drain the circulating fluid.

**5** Apply air purge from the the circulating fluid return to push the circulating fluid remaining in the heat exchange back in the tank and drain it.

**CAUTION**

 If the recovered circulating fluid is contaminated by foreign substances, completely remove them. Do not reuse contaminated fluid.  
Potential insufficient cooling, system failure and froth in the circulating fluid may occur if disregarded.

**CAUTION**

 Recovered circulating fluid must be sealed in a container to prevent contamination from moisture or foreign substances.  
Stored in a cool, dark place. Keep it from flame.

**6** Upon completion of fluid draining, close the valves of the main and sub tank drain ports.

**7** Add plugs to seal off ports on the rear of this system.

See "7.3.2 Draining of Facility Water" for plug attachment.

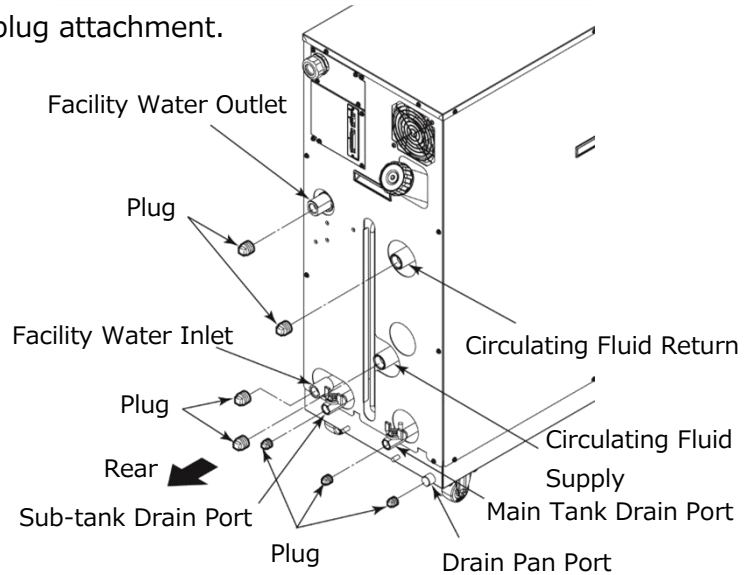

Fig. 7-2 Plug Attachment

### 7.3.2 Draining of Facility Water

#### **CAUTION**



Be sure to drain the facility water only when it is at room temperature. Trapped fluid inside the system can still be hot. Potential burns can occur if disregarded.

**1** Place the drain pan underneath the piping connections on the rear of this system.

A 7L-capacity or bigger drain pan is required.

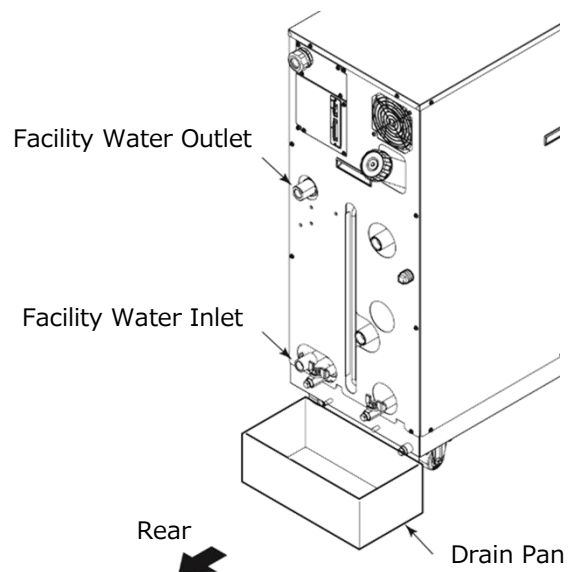

Fig. 7-3 Drain Pan Attachment.

## 2 Remove facility water piping

Remove the joints such as unions if present.

---

## 3 Drain the facility water using the facility water inlet port.

# 7.4 Periodic Replacement Parts

Replacement of consumables listed in the following table is recommended. Contact the system supplier for request of part replacement.

Table 7-4 Periodic Replacement Part List

Part	Recommended Replacement Cycle
Internal Pump	Every 3 years
Circulating Pump	Every 3 years
Ventilating Fan	Every 3 years
Inverter Cooling Fan	Every 3 years

Note: A replacement cycle may vary with your usage condition

# Chapter 8 Appendix

## 8.1 Specification

### 8.1.1 System Specification

■ Specification for Fluorinated Fluid (Wide Temperature)

Table 8-1 Specification for Fluorinated Fluid (Wide Temperature)

Model		HRZF010-WS	
Cooling Method		Water Cooled Refrigerant	
Cooling Capacity* <sup>1</sup> (50Hz/60Hz)	kW	10	
Operating Temperature Range	deg. C	-20.0 to 90.0	
Temperature Stability	deg. C	±0.1* <sup>2</sup>	
Circulating Fluid		Galden® HT135* <sup>3</sup> Fluorinert™ FC-3283* <sup>3</sup> (-20 to 40 deg. C) Galden® HT200* <sup>3</sup> Fluorinert™ FC-40* <sup>3</sup> (20 to 90 deg. C) (No Intrusion of Foreign Body)	
Refrigerant		R454C (HFO/HFC, GWP148)* <sup>11</sup>	
Quantity of Refrigerant	kg	1.5	
Pump Capacity* <sup>4</sup>	MPa	0.72 (At 20L/min) (104[PSIG] At 5.3 [gal/min])	
Main Tank Capacity* <sup>5</sup>	L	Approx.15 (4 [gal])	
Sub-tank Capacity* <sup>6</sup>	L	Approx.16 (4.2 [gal])	
Circulating Fluid Port		Rc 3/4	
Facility Water	deg. C /MPa	10 to 30 / 0.3 to 0.7 (45 to 100 [PSIG])	
Facility Water Required Flow Rate	Rated Condition* <sup>9</sup>	L/min	15
	Temp. Changing Condition* <sup>10</sup>		15
Facility Water Port		Rc 1/2	
Power Supply		3-phase 50/60Hz AC200/200 to 208V±10%	
Breaker Size	A	30	
Dimensions* <sup>7</sup>	mm	W380xD870xH950 (W14.96xD34.25xH37.40[inch])	
Weight* <sup>8</sup>	kg	165 (364 [lbs.])	
Communication		Serial RS-485 (Dsub-9pin), Contact Signal (Dsub-25pin)	

\*1: The capacity is derived under the conditions that the circulating fluid temp is 20 deg. C, the facility water temp. is 25 deg. C and that the circulating fluid flow rate is obtained at a specified flow rate of pump capacity.

\*2: This is a system output temperature, with flow rate defined in pump capacity secured, when stabilized with no disturbance. Its upper limit may be violated if an insufficient amount of the circulating fluid is present or a disturbance to flow rate is observed.

\*3: Galden® is a registered trademark of Solvay, and Fluorinert™ is a trademark of U.S. 3M.

\*4: The capacity is derived at the Outlet of this system when the circulating fluid temp. is at 20 deg. C and maximum frequency operation by inverter.

\*5: This is a minimum amount of the fluid for operation of the Thermo Chiller outfitted with internal piping and heat exchanger in this system. Circulating fluid temp.: 20deg. C

\*6: For circulating fluid containment during line purge back or back flow. This is the volume of free space in Sub-Tank when fluid level is at "High" level. Main-Tank capacity is excluded.

\*7: This is the dimensions of panels, which is derived without protrusions such as a breaker handle.

\*8: This is the mass of the system when it contains no circulating fluid.

\*9: The required flow rate when the cooling capacity load is applied under the condition in \*1.

\*10: Temporarily required flow rate when set temperature is changed under the facility water temp.25 deg. C.

\*11: The value of IPCC (Intergovernmental Panel on Climate Change) Forth Assignment Report: Climate Change 2007 (AR4).

■ Specification for 60% Ethylene Glycol Aqueous Solution (Wide Temperature)

Table 8-2 Specification for 60% Ethylene Glycol Aqueous Solution (Wide Temperature)

Model		HRZF010-W1S
Cooling Method		Water Cooled Refrigerant
Cooling Capacity* <sup>1</sup> (50Hz/60Hz)	kW	10
Operating Temperature Range	deg. C	-20.0 to 90.0
Temperature Stability	deg. C	±0.1* <sup>2</sup>
Circulating Fluid		60% Ethylene Glycol Aqueous Solution* <sup>3</sup> (No Intrusion of Foreign Body)
Refrigerant		R454C (HFO/HFC, GWP148) * <sup>11</sup>
Quantity of Refrigerant	kg	1.5
Pump Capacity* <sup>4</sup>	MPa	0.40 (At 20L/min) (58[PSIG] At 5.3 [gal/min])
Main Tank Capacity* <sup>5</sup>	L	Approx.15 (4 [gal])
Sub-tank Capacity* <sup>6</sup>	L	Approx.16 (4.2 [gal])
Circulating Fluid Port		Rc 3/4
Facility Water	deg. C /MPa	10 to 30 / 0.3 to 0.7 (45 to 100 [PSIG])
Facility Water Required Flow Rate	Rated Condition* <sup>9</sup>	15
	Temp. Changing Condition* <sup>10</sup>	15
Facility Water Port		Rc 1/2
Power Supply		3-phase 50/60Hz AC200/200 to 208V±10%
Breaker Size	A	30
Dimensions* <sup>7</sup>	mm	W380×D870×H950 (W14.96xD34.25xH37.40[inch])
Weight* <sup>8</sup>	kg	165 (364 [lbs.])
Communication		Serial RS-485 (Dsub-9pin), Contact Signal (Dsub-25pin)

- \*1: The capacity is derived under the conditions that the circulating fluid temp is 20 deg. C, the facility water temp. is 25 deg. C and that the circulating fluid flow rate is obtained at a specified flow rate of pump capacity.
- \*2: This is a system output temperature, with flow rate defined in pump capacity secured, when stabilized with no disturbance. Its upper limit may be violated if an insufficient amount of the circulating fluid is present or a disturbance to flow rate is observed.
- \*3: Pure ethylene glycol needs dilution with fresh water before use. Ethylene glycol with additives such as preservatives is NOT available. It not only deteriorates the performance, but also lead to cause failure.
- \*4: The capacity is derived at the Outlet of this system when the circulating fluid temp. is at 20 deg. C and maximum frequency operation by inverter.
- \*5: This is a minimum amount of the fluid for operation of the Thermo Chiller outfitted with internal piping and heat exchanger in this system. Circulating fluid temp.: 20 deg. C
- \*6: For circulating fluid containment during line purge back or back flow. This is the volume of free space in Sub-Tank when fluid level is at "High" level. Main-Tank capacity is excluded.
- \*7: This is the dimensions of panels, which is derived without protrusions such as a breaker handle.
- \*8: This is the mass of the system when it contains no circulating fluid.
- \*9: The required flow rate when the cooling capacity load is applied under the condition in \*1.
- \*10: Temporarily required flow rate when set temperature is changed under the facility water temp.25 deg. C.
- \*11: The value of IPCC (Intergovernmental Panel on Climate Change) Forth Assignment Report: Climate Change 2007 (AR4).



## 8.1.2 Cooling Capacity

### ■ HRZF010-WS

Fluid : Fluorinated Fluid  
Flow Rate : Rated Flow  
Facility Water Temp. : 25 deg. C

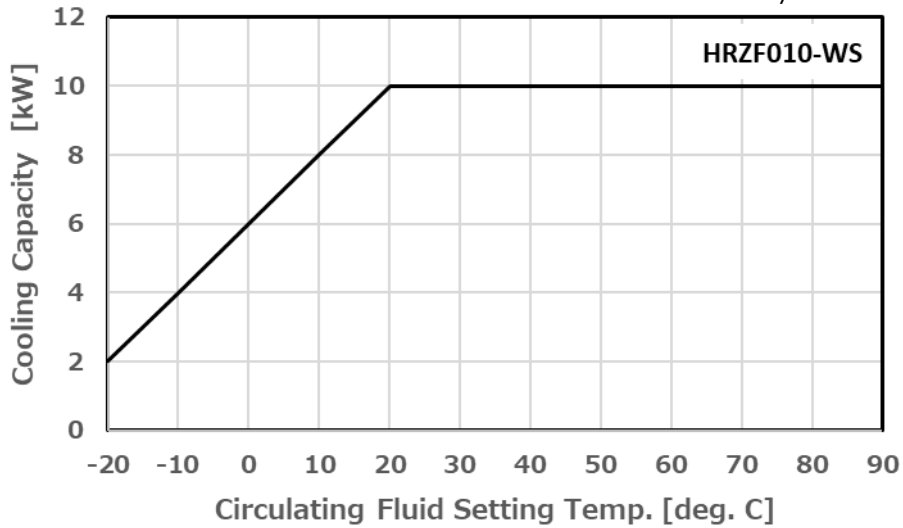

Fig. 8-1 Cooling Capacity of HRZF010-WS (Common to 50/60Hz)

### ■ HRZF010-W1S

Fluid : 60% Ethylene Glycol Aqueous Solution  
Flow Rate : Rated Flow  
Facility Water Temp. : 25 deg. C

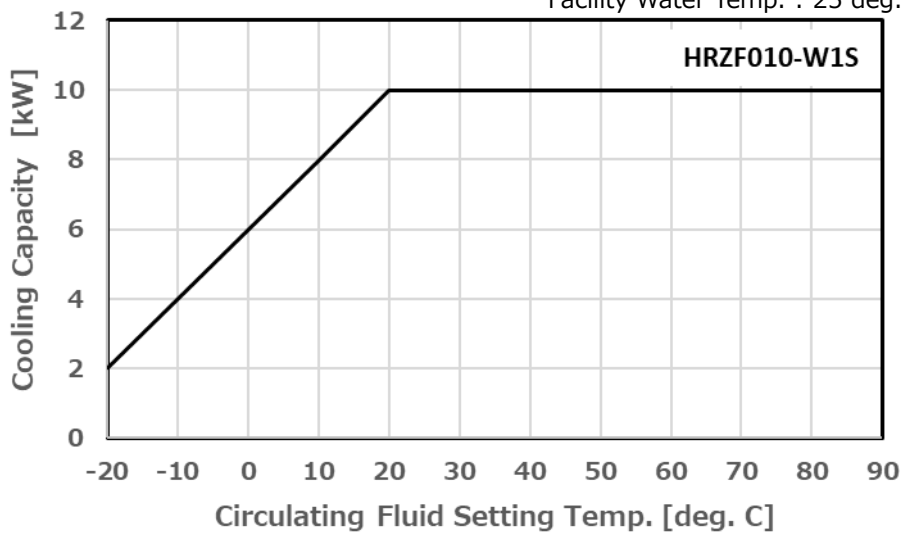

Fig. 8-2 Cooling capacity of HRZF010-W1S (Common to 50/60Hz)

### 8.1.3 Heating Capacity

#### ■ HRZF010-WS

Fluid : Fluorinated Fluid  
Flow Rate : Rated Flow

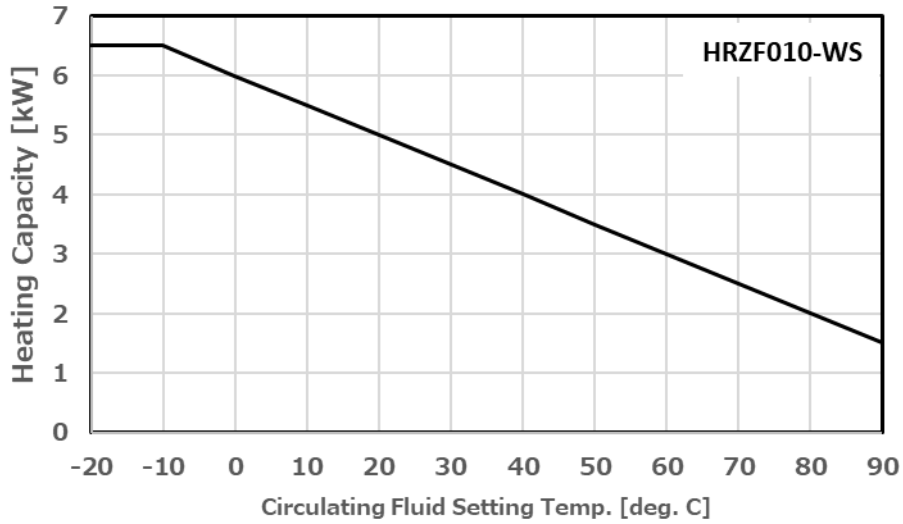

Fig. 8-3 Heating Capacity of HRZF010-WS

\*When pump inverter is operating at frequency of 60Hz (maximum)

#### ■ HRZF010-W1S

Fluid : 60% Ethylene Glycol Aqueous Solution  
Flow Rate : Rated Flow

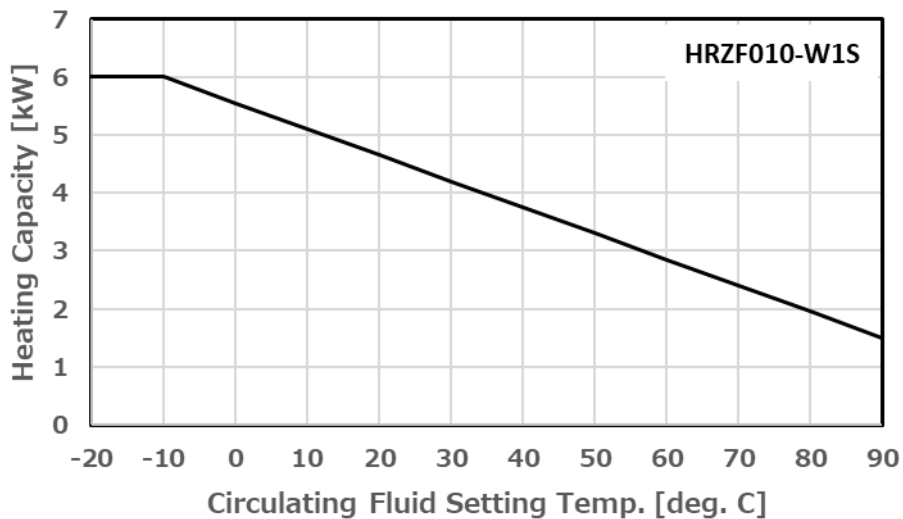

Fig. 8-4 Heating Capacity of HRZF010-W1S

\*When pump inverter is operating at frequency of 60Hz (maximum)

### 8.1.4 Pump Performance Curve

#### ■ HRZF010-WS

Fluid : Fluorinated Fluid  
Flow Rate : Rated Flow

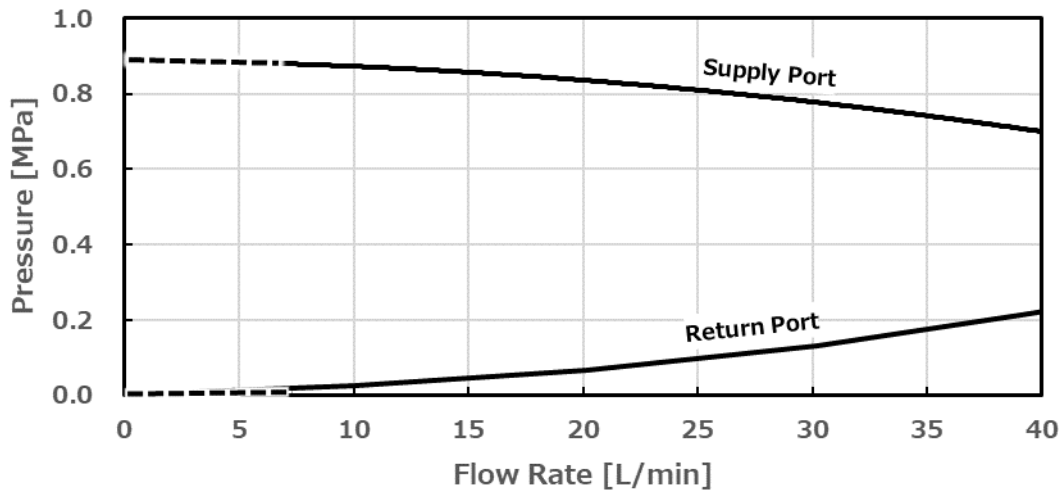

Fig. 8-5 H Pump Performance Curve of HRZF010-WS

When circulating fluid flow rate lowers 6L/min an alarm will occur and operation can't be performed.

#### ■ HRZF010-W1S

Fluid : 60% Ethylene Glycol Aqueous Solution  
Flow Rate : Rated Flow

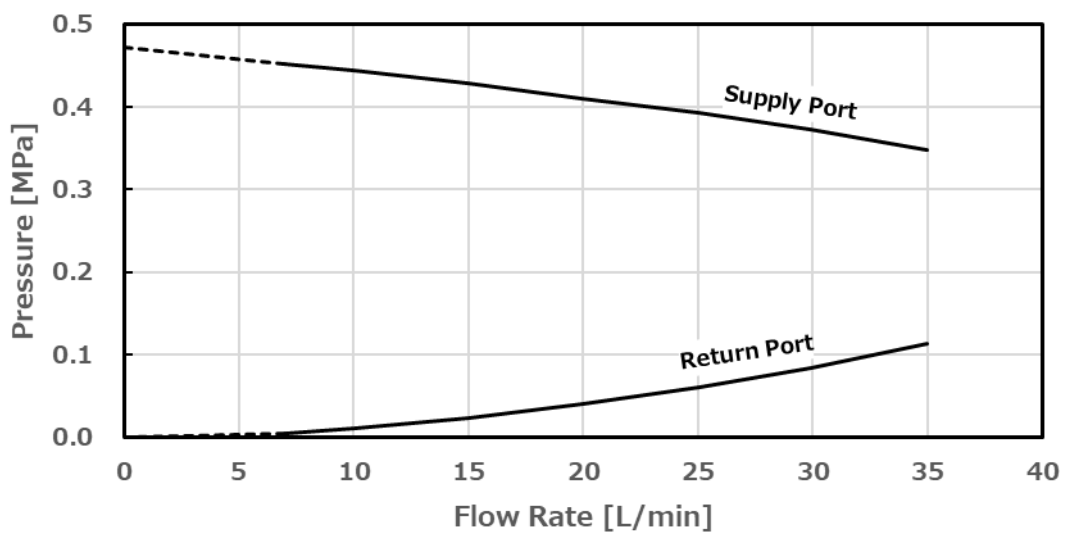

Fig. 8-6 H Pump Performance Curve of HRZF010-W1S

When circulating fluid flow rate lowers 6L/min an alarm will occur and operation can't be performed.

## 8.1.5 Refrigerant with GWP Reference

Table 8-3 GWP Reference

Refrigerant	Global Warming Potential (GWP)	
	Regulation (EU) No 517/2014 (Based on the IPCC AR4)	Revised Fluorocarbons Recovery and Destruction Law (Japanese Law)
R454C	148	145

This product is hermetically sealed and contains fluorinated greenhouse gases.

## 8.1.6 Communication Specifications

This section provides the general outline of communications utilized in this system. For detail specification, we provide a separate system manual "Communication Specification", which is available through your local distributor.

■ Contact Signal

Table 8-4 Contact Signal

Item		Specification																																																																																																	
Connector No.		P1																																																																																																	
Connector Type (This System)		D-sub25P Female Connector(M2.6x0.45)																																																																																																	
Input Signal	Insulation Type	Photocoupler																																																																																																	
	Rated Input Voltage	DC24V																																																																																																	
	Used Voltage Range	DC 21.6V to 26.4V																																																																																																	
	Rated Input Current	5mA TYP																																																																																																	
	Input Impedance	4.7kΩ																																																																																																	
Contact Output Signal (Other Than Pin No. 5-18)	Rated Load Voltage	Max. AC48V / Max. DC30V																																																																																																	
	Max. Load Current	Max. AC/DC 800mA (Pin No. 15 is common to output signals. Total used load current should be at or below 800mA)																																																																																																	
Contact Output Signal (Pin No. 5-18)	Rated Load Voltage	Max. AC48V / Max. DC30V																																																																																																	
	Max. Load Current	AC/DC 800mA (resistance load)																																																																																																	
Contact Output Signal (EMO Signal)	Rated Load Voltage	Max. AC48V / Max. DC30V																																																																																																	
	Max. Load Current	AC/DC 800mA (Resistance Load, Inductive Load)																																																																																																	
Analog Input Signal*2	Input Voltage Range	-10 to +10V																																																																																																	
	Input Impedance	1MΩ																																																																																																	
	Input Accuracy	±0.2% F.S. or Less																																																																																																	
Analog Output Signal*2	Output Voltage Range	-10 to +10V																																																																																																	
	Max. Output Current	10mA																																																																																																	
	Output Accuracy	±0.2% F.S. or Less																																																																																																	
Circuit block diagram																																																																																																			
	<table border="1"> <thead> <tr> <th rowspan="2">Pin No</th> <th rowspan="2">I/O</th> <th colspan="2">ITEM</th> </tr> <tr> <th>Standard specification</th> <th>CUSTOM DIO</th> </tr> </thead> <tbody> <tr> <td>1</td> <td>Output</td> <td>DC+24V output</td> <td>DC+24V output</td> </tr> <tr> <td>2</td> <td>Input</td> <td>Input signal COM</td> <td>Input signal COM</td> </tr> <tr> <td>14</td> <td>Output</td> <td>24COM</td> <td>24COM</td> </tr> <tr> <td>3</td> <td>Input</td> <td>Run/Stop signal</td> <td>Run/Stop signal 1</td> </tr> <tr> <td>16</td> <td>Input</td> <td>-</td> <td>Run/Stop signal 2</td> </tr> <tr> <td>4</td> <td>Input</td> <td>AUTO PURGE signal<sup>1</sup></td> <td>DIO REMOTE signal 1 AUTO PURGE signal<sup>1</sup></td> </tr> <tr> <td>17</td> <td>Input</td> <td>-</td> <td>DIO REMOTE signal 2</td> </tr> <tr> <td>6</td> <td>Output</td> <td>Run status signal</td> <td>OUT1</td> </tr> <tr> <td>19</td> <td>Output</td> <td>Warning signal</td> <td>OUT2</td> </tr> <tr> <td>7</td> <td>Output</td> <td>Fault signal</td> <td>OUT3</td> </tr> <tr> <td>20</td> <td>Output</td> <td>Remote signal</td> <td>OUT4</td> </tr> <tr> <td>8</td> <td>Output</td> <td>TEMP READY signal AUTO PURGE status signal</td> <td>OUT5</td> </tr> <tr> <td>15</td> <td>Input</td> <td>Output signal COM</td> <td>Output signal COM</td> </tr> <tr> <td>5</td> <td>Output</td> <td>Alarm signal</td> <td>OUT6</td> </tr> <tr> <td>18</td> <td>Output</td> <td>Alarm signal</td> <td>OUT6</td> </tr> <tr> <td>11</td> <td>Output</td> <td>Temp.PV Analog Output*2</td> <td>Temp.PV Analog Output*2</td> </tr> <tr> <td>23</td> <td>Output</td> <td>[-100 to 100deg C:-10 to 10V]</td> <td>[-100 to 100deg C:-10 to 10V]</td> </tr> <tr> <td>10</td> <td>Output</td> <td>DI PV Analog Output*3</td> <td>DI PV Analog Output*3</td> </tr> <tr> <td>22</td> <td>Output</td> <td>[0 to 20 MΩ:0 to 10V]</td> <td>[0 to 20 MΩ:0 to 10V]</td> </tr> <tr> <td>12</td> <td>Input</td> <td>Temp.SP Analog Input*3</td> <td>Temp.SP Analog Input*3</td> </tr> <tr> <td>24</td> <td>Input</td> <td>[-100 to 100 deg C:-10 to 10V]</td> <td>[-100 to 100 deg C:-10 to 10V]</td> </tr> <tr> <td>13</td> <td>Output</td> <td>EMO signal</td> <td>EMO signal</td> </tr> <tr> <td>25</td> <td>Output</td> <td>EMO signal</td> <td>EMO signal</td> </tr> </tbody> </table>		Pin No	I/O	ITEM		Standard specification	CUSTOM DIO	1	Output	DC+24V output	DC+24V output	2	Input	Input signal COM	Input signal COM	14	Output	24COM	24COM	3	Input	Run/Stop signal	Run/Stop signal 1	16	Input	-	Run/Stop signal 2	4	Input	AUTO PURGE signal <sup>1</sup>	DIO REMOTE signal 1 AUTO PURGE signal <sup>1</sup>	17	Input	-	DIO REMOTE signal 2	6	Output	Run status signal	OUT1	19	Output	Warning signal	OUT2	7	Output	Fault signal	OUT3	20	Output	Remote signal	OUT4	8	Output	TEMP READY signal AUTO PURGE status signal	OUT5	15	Input	Output signal COM	Output signal COM	5	Output	Alarm signal	OUT6	18	Output	Alarm signal	OUT6	11	Output	Temp.PV Analog Output*2	Temp.PV Analog Output*2	23	Output	[-100 to 100deg C:-10 to 10V]	[-100 to 100deg C:-10 to 10V]	10	Output	DI PV Analog Output*3	DI PV Analog Output*3	22	Output	[0 to 20 MΩ:0 to 10V]	[0 to 20 MΩ:0 to 10V]	12	Input	Temp.SP Analog Input*3	Temp.SP Analog Input*3	24	Input	[-100 to 100 deg C:-10 to 10V]	[-100 to 100 deg C:-10 to 10V]	13	Output	EMO signal	EMO signal	25	Output	EMO signal
Pin No	I/O	ITEM																																																																																																	
		Standard specification	CUSTOM DIO																																																																																																
1	Output	DC+24V output	DC+24V output																																																																																																
2	Input	Input signal COM	Input signal COM																																																																																																
14	Output	24COM	24COM																																																																																																
3	Input	Run/Stop signal	Run/Stop signal 1																																																																																																
16	Input	-	Run/Stop signal 2																																																																																																
4	Input	AUTO PURGE signal <sup>1</sup>	DIO REMOTE signal 1 AUTO PURGE signal <sup>1</sup>																																																																																																
17	Input	-	DIO REMOTE signal 2																																																																																																
6	Output	Run status signal	OUT1																																																																																																
19	Output	Warning signal	OUT2																																																																																																
7	Output	Fault signal	OUT3																																																																																																
20	Output	Remote signal	OUT4																																																																																																
8	Output	TEMP READY signal AUTO PURGE status signal	OUT5																																																																																																
15	Input	Output signal COM	Output signal COM																																																																																																
5	Output	Alarm signal	OUT6																																																																																																
18	Output	Alarm signal	OUT6																																																																																																
11	Output	Temp.PV Analog Output*2	Temp.PV Analog Output*2																																																																																																
23	Output	[-100 to 100deg C:-10 to 10V]	[-100 to 100deg C:-10 to 10V]																																																																																																
10	Output	DI PV Analog Output*3	DI PV Analog Output*3																																																																																																
22	Output	[0 to 20 MΩ:0 to 10V]	[0 to 20 MΩ:0 to 10V]																																																																																																
12	Input	Temp.SP Analog Input*3	Temp.SP Analog Input*3																																																																																																
24	Input	[-100 to 100 deg C:-10 to 10V]	[-100 to 100 deg C:-10 to 10V]																																																																																																
13	Output	EMO signal	EMO signal																																																																																																
25	Output	EMO signal	EMO signal																																																																																																
*1: The recovery signal can be input only when the circulating fluid automatic collection function (optional) is used, and it does not serve as the DIO REMOTE signal.																																																																																																			
*2 :Valid if Analog Communication (optional) is provided.																																																																																																			
*3 :Valid if DI Control Kit (optional) is provided.																																																																																																			

■ Serial RS-485

Table 8-5 Serial RS-485

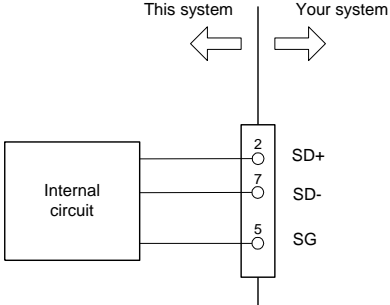
Item	Specification
Connector No.	P2
Connector Type (this system)	D-sub9P female connector
Standard	EIA RS485
Protocol	Modicon Modbus
Circuit Block Diagram	 <p>The diagram shows an 'Internal circuit' box connected to a vertical P2 connector. The connector has three pins: pin 2 labeled 'SD+', pin 7 labeled 'SD-', and pin 5 labeled 'SG'. Above the connector, a vertical line represents the RS-485 bus. Two arrows point towards each other on this line, labeled 'This system' and 'Your system', indicating bidirectional communication.</p>

### 8.1.7 Alarm Signal Selection

User can designate one alarm signal for contact signal. See “5.3.22 Initial Setting Screen 7” on page 5-24 for signal selecting.

The following table presents the setting-alarm relationship. The alarm signal is turned OFF if the designated alarm detected. (Alarm signal is ON if no alarm is detected.)

Table 8-6 Alarm signal Selection

Setting	Alarm	Alarm No.
N/A	Alarm signal remains ON (closed) under normal circumstances.	–
ALARM01	Water Leak Detect FLT	01
ALARM03	RFGT High Press FLT	03
ALARM04	CPRSR Overheat FLT	04
ALARM05	Reservoir Low Level FLT	05
ALARM06	Reservoir Low Level WRN	06
ALARM07	Reservoir High Level WRN	07
ALARM08	Temp. Fuse Cutout FLT	08
ALARM09	Reservoir High Temp. FLT	09
ALARM10	Return High Temp. WRN	10
ALARM11	Reservoir High Temp. WRN	11
ALARM12	Return Low Flow FLT	12
ALARM13	Return Low Flow WRN	13
ALARM19	FAN Motor Stop WRN	19
ALARM20	Internal Pump Time Out WRN	20
ALARM21	Controller Error FLT	21
ALARM22	Memory Data Error FLT	22
ALARM23	Communication Error	23
ALARM24 <sup>*1</sup>	DI Low Level WRN	24
ALARM25	Pump Inverter Error FLT	25
ALARM28	CPRSR Inverter Error FLT	28
ALARM29	RFGT Low Press FLT	29
ALARM32	Reservoir Low Temp. WRN	32

● Example

With parameter “OUT” on the Initial Setting screen set to “Alarm1”, alarm “Water Leak Detect FLT” is detected, the alarm contact signal is switched to OFF (open).

\*1 : Alarm 24 is alarm assigned to accessories (optional).



## 8.2 Outer Dimensions

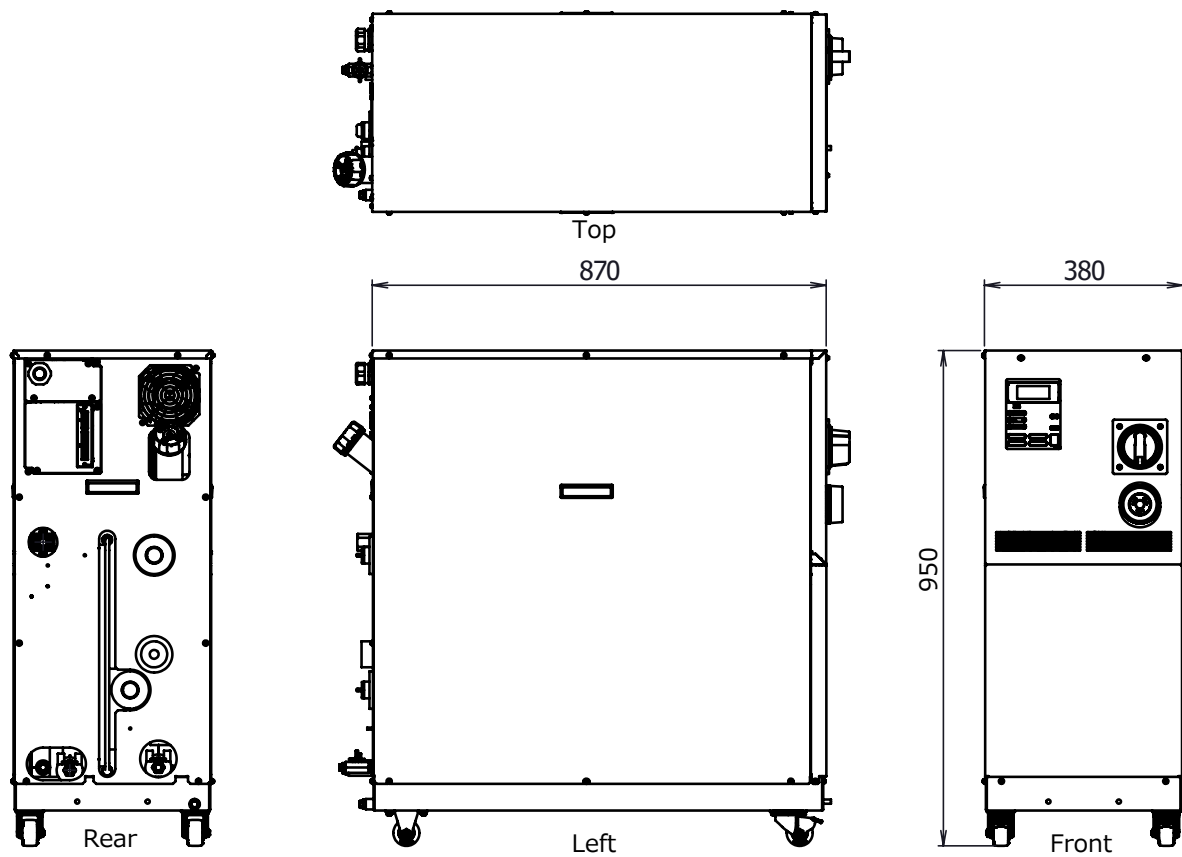

Fig. 8-7 Outer Dimensions

## 8.3 Flow Chart

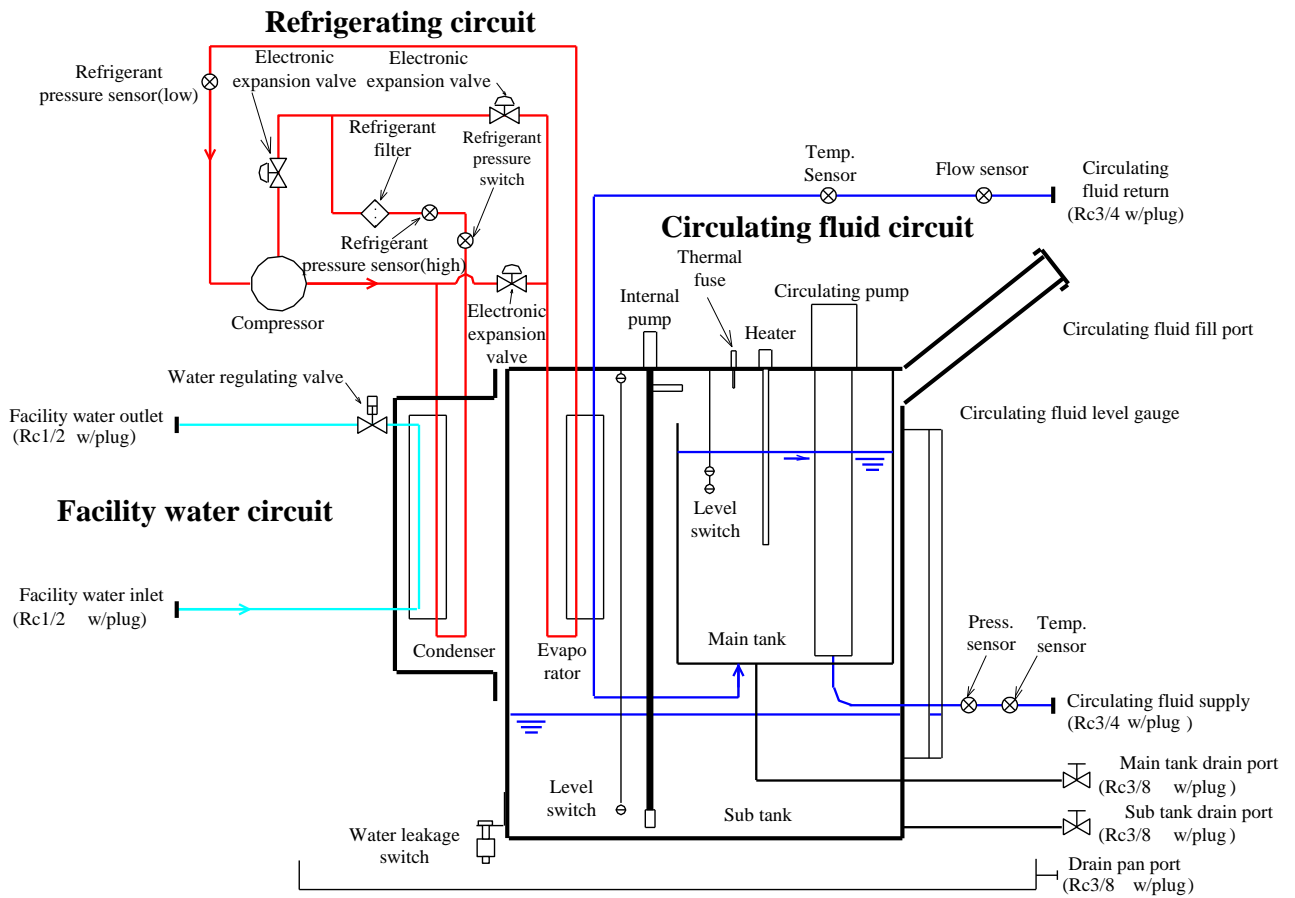

Fig. 8-8 Flow Chart

## 8.4 Offset Function

Potential deviations in temperature between this system and your system may be concerned depending on the installation environment. The offset function falling into three types (MODE1 to 3) is assigned to calibrate deviations in temperature.

See the following descriptions for the offset function. See "5.3.16 Initial Setting Screen 1" on page 5-18 for setting.

TEMP PV value, which is displayed on the Status screen, is output as circulating fluid temperature data in terms of communication.

- When MODE 1 is selected

This mode is used to exercise temperature control to allow the discharge temperature of the circulating fluid to be "TEMP SP value + OFFSET value".

TEMP PV value denotes the discharge temperature of the circulating fluid.

(E.g.: TEMP SP value : +20deg. C, OFFSET value : +2deg. C→

Circulating fluid discharge temp. : +22deg. C, TEMP PV : +22deg. C

- When MODE 2 is selected

This mode is used to exercise temperature control to allow the discharge temperature of the circulating fluid to be "TEMP SP value".

TEMP PV value denotes "Circulating fluid discharge temp. value + OFFSET value".

(E.g.: TEMP SP value : +20deg. C, OFFSET value : +2deg. C→

Circulating fluid discharge temp. : +20deg. C, TEMP PV : +22deg. C

- When MODE 3 is selected

This mode is used to exercise temperature control to allow the discharge temperature of the circulating fluid to be "TEMP SP value + OFFSET value".

TEMP PV value denotes "Circulating fluid discharge temp. value - OFFSET value".

(E.g.: TEMP SP value : +20deg. C, OFFSET value : +2deg. C→

Circulating fluid discharge temp. : +20deg. C, TEMP PV : +20deg. C

- When OFF is selected

If no mode is selected, temperature control is conducted to allow the discharge temperature of the circulating fluid to be "TEMP SP value".

### 8.4.1 Example of Offset Function

When the discharge temperature of the circulating fluid is at 30deg. C, heat is dissipated by 1deg. C to allow the circulating fluid in your system to be 29deg. C. Under the above condition, the following process is to be performed with the utilization of MODEs 1 to 3.

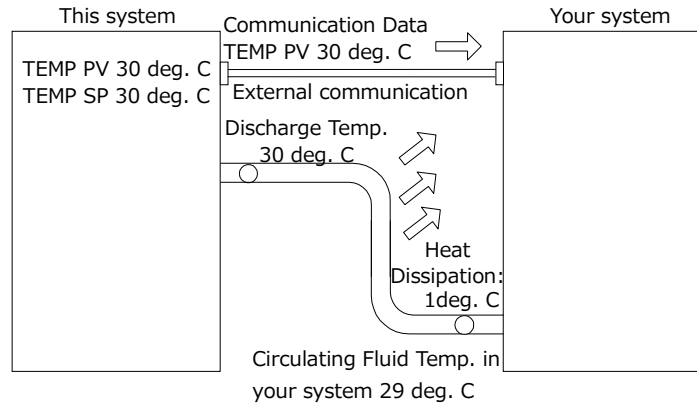

Fig. 8-9 Example of Offset Function

#### ■ When MODE 1 is Selected

This mode enables this system to exercise temperature control to obtain 31 deg. C (TEMP SP value +OFFSET value), with OFFSET value set at 1deg. C. Once the discharge temperature of the circulating fluid becomes 31 deg. C, 1 deg. C-thermal dissipation is assured to allow the circulating fluid in your system to be 30 deg. C. TEMP SP value is obtained for your system. Note that "31deg. C" is recorded in TEMP PV and communication data.

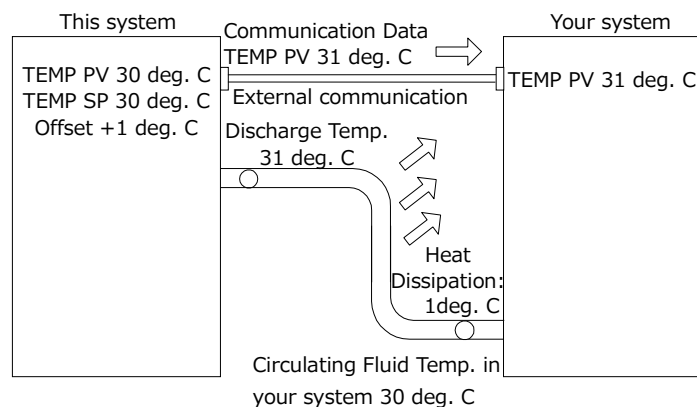

Fig. 8-10 When MODE 1 is selected

■ **When MODE 2 is Selected**

With OFFSET value set at -1 deg. C, TEMP PV and communication data express "29deg. C" (circulating fluid discharge temp. value + OFFSET value) that agrees with the temperature of the circulating fluid in your system.

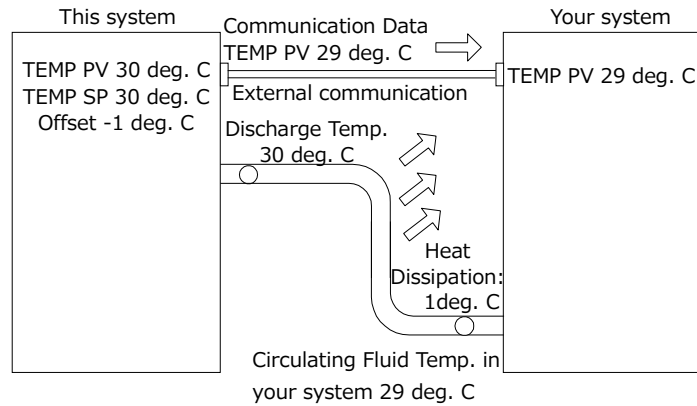

Fig. 8-11 When MODE 2 is selected

■ **When MODE 3 is Selected**

This mode enables this system to exercise temperature control to obtain 31deg. C (TEMP SP value + OFFSET value), with OFFSET value set at 1deg. C. Once the discharge temperature of the circulating fluid becomes 31deg. C, 1deg. C-thermal dissipation is assured to allow the circulating fluid in your system to be 30deg. C. TEMP SP value is obtained for your system. TEMP PV and communication data also express "30deg. C" (circulating fluid discharge temp. value - OFFSET value) that agrees with the temperature of the circulating fluid in your system.

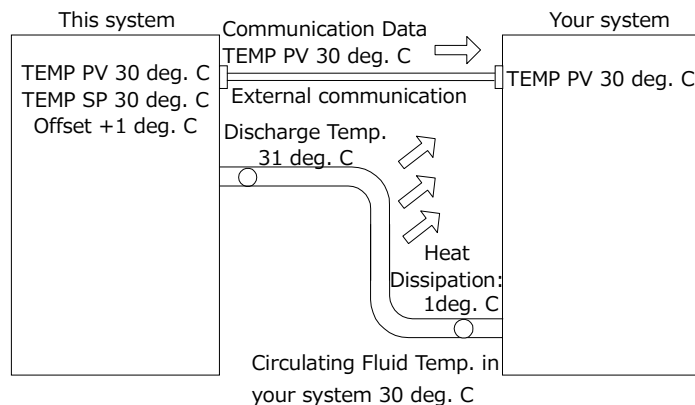

Fig. 8-12 When MODE 3 is selected

## 8.5 BAND/READY Function

Sets BAND to TEMP SP value and notifies TEMP PV value reaches within BAND range by the operation display panel or the communication.

See "5.3.21 Initial Setting Screen 6" on page 5-23, for the procedure of the setting.

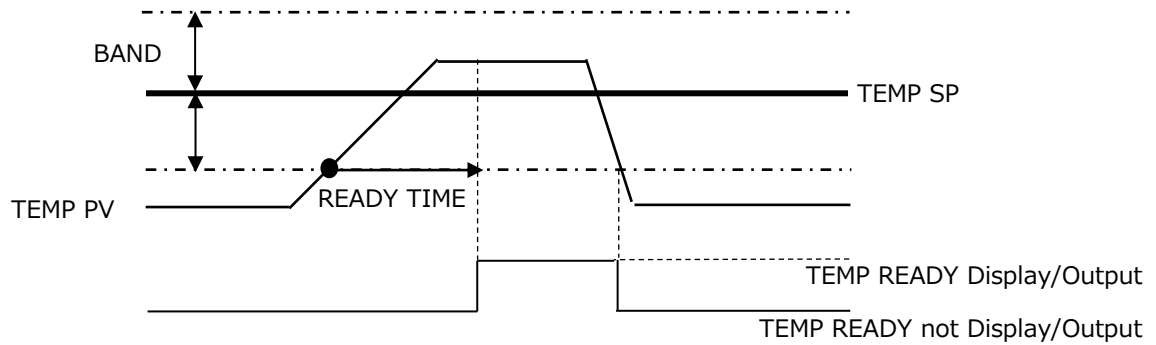

Fig. 8-13 BAND/READY Function

- Example of Setting  
TEMP SP : 20deg. C  
BAND : 2deg. C  
READY TIME : 60sec.

"TEMP READY" is displayed on the operation display panel 60-sec. after TEMP PV value becomes 18 deg. C to start output by communication.

Necessary condition is that TEMP PV value after 60-sec. is 20+/-2.0 deg. C or less. See "5.3.4 Status Screen 3" on page 5-7 for the details of display position.

## 8.6 Anchor Bolt Mounting Position

Lock the brakes on casters (2 pcs. on the front) and attach the anti-seismic bracket (optional: HRZ-TK002) to secure this system.

### ⚠ CAUTION



Anti-seismic bracket is an optional accessory, which is required for the installation of this system (HRZ-TK002).

It is your responsibility to prepare anchor bolts suitable for your floor material. M12-anchor bolts (4 pcs.) are required.

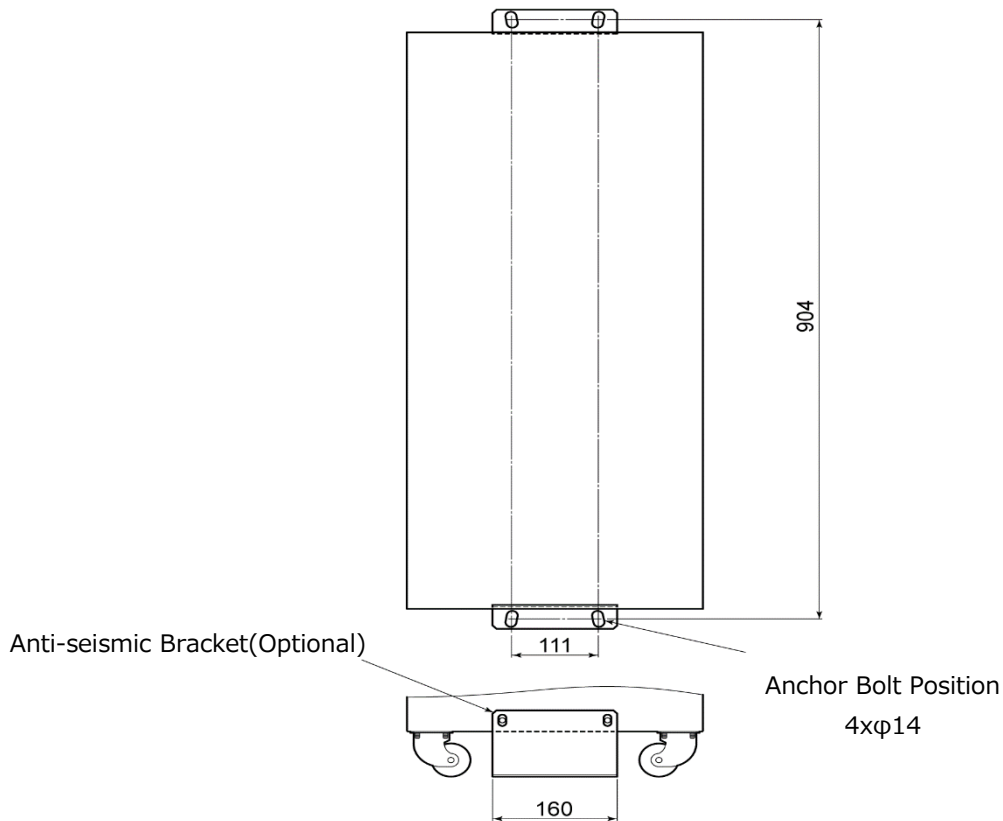

Fig. 8-14 Anchor Bolt Position

## 8.7 Compliance

This system conforms to the following standards.

Table 8-7 Compliance

<b>CE Marking</b>	EMC Directive	2014/30/EU
	Machinery Directive	2006/42/EC
	RoHS Directive	2011/65/EU
<b>SEMI</b>	S2, S8, F47	
<b>UL</b>	UL60335-2-89	



# 8.8 Thermo Chiller Daily Inspection Sheet

To Confirm Daily Inspection Item on The Thermo Chiller, See "7.2.1 Daily Inspection".

	Model	Serial No.																				
Your name	Date	Temp.	Humidity	Installation		Leakage		Fluid Level	Operation display panel		Circulating fluid temp.	Refrigerant press.	Circulating fluid outlet press.	Circulating fluid flowrate	Operating condition	Facility water		Circulating fluid supply port cap		Judgment		
	°C	%	Yes/No	Yes/No	Yes/No	IN/OUT of range	Display	Function	°C	MPa	MPa	L/min	Error	Temp.	Flowrate	IN press.	Looseness	Yes/No				
After installation (initial value)																						



# Chapter 9 Product Warranty

## 9.1 Warranty

If a failure is observed in our Thermo Chiller, repair shall be provided in accordance with the warranty period and preconditions defined below at SMC's option.

Repair involves the inspection and/or replacement and/or modification of a defective part.

Removed parts shall become the possession of SMC.

This guarantee applies only to our product independently, and not to any other damage incurred due to the failure of the product.

## 9.2 Warranty Period

The warranty period of the product is 1 year in service or 1.5 years after the product is delivered, whichever is first.

## 9.3 Warranty Exemption

SMC's liability under this warranty shall not be available for the following troubles and damages.

- (1) The product was incorrectly installed or connected with other equipment.
- (2) The failure was a secondary failure of the product caused by the failure of equipment connected to the product.
- (3) Troubles or damage caused by the neglect of our designated inspection (daily inspection, periodic inspection).
- (4) Troubles or damages caused by mishandling such as using improper operating procedure and using with our specifications violated.
- (5) Troubles or damages caused by unauthorized modification.
- (6) Troubles or damages caused by the use of a not-designated circulating fluid and facility water.
- (7) Troubles or damages caused by wearing out such as fading on the coated or plated surface.
- (8) Sensory phenomena that are considered no effect on the functions (such as noise, vibration).
- (9) Troubles or damages caused by natural disaster such as earthquake, typhoon, water, inevitable events and fire.
- (10) Troubles or damages occurred under the installation conditions defined in the Operation Manual.
- (11) Troubles or damages that are not compliant with the "5. Warranty preconditions".

## 9.4 Escape Clause

- (1) Expenses of daily inspection and periodic inspection.
- (2) Expenses of repair consigned with neither SMC nor our authorized service station.
- (3) Expenses of transport, installation, and removal of this system.
- (4) Expenses of removal of non-genuine parts and replenishment of non-genuine fluids.
- (5) Unavailability and loss due to this system being disabled.  
(Such as telephone bill, leave compensation, commercial loss)
- (6) Expenses and compensation for terms other than provided in "9.1 Warranty".

## 9.5 Warranty Precondition

Proper use and inspection of this system is required to assure safe use of this system. System warranty shall satisfy the following preconditions. Please take note that warranted repair shall not be available if these preconditions are disregarded.

- (1) System operation shall be conducted by following operating procedure defined in the Operation Manual.
- (2) Daily and periodic inspections designated in the Operation Manual shall be made as scheduled.
- (3) Inspection record shall be entered in the Daily Inspection Sheet provided in the Operation Manual.

## 9.6 Request for Warranted Repair

As to warranted repair, please contact the supplier you purchased this system from for service. Warranted repair shall be on request basis.

Unrequited repair shall be provided in accordance with the warranty period, preconditions and terms defined above. Therefore, the repair service shall be available on a chargeable basis if a failure is detected after the warranty period.



Revision
Rev. 2 Apr. 2024

## SMC Corporation

4-14-1, Sotokanda, Chiyoda-ku, Tokyo 101-0021 JAPAN

Tel: + 81 3 5207 8249 Fax: +81 3 5298 5362

URL <https://www.smcworld.com>

---

Note: Specifications are subject to change without prior notice and any obligation on the part of the manufacturer.

© SMC Corporation All Rights Reserved