



Operation Manual

Original Instructions

PRODUCT NAME

Thermo Chiller

MODEL / Series / Product Number

HRZC002-WS	HRZC002-W1S	HRZC002-W2S
HRZC004-WS	HRZC004-W1S	HRZC004-W2S
HRZC008-WS	HRZC008-W1S	HRZC008-W2S
HRZC010-WS	HRZC010-W1S	HRZC010-W2S

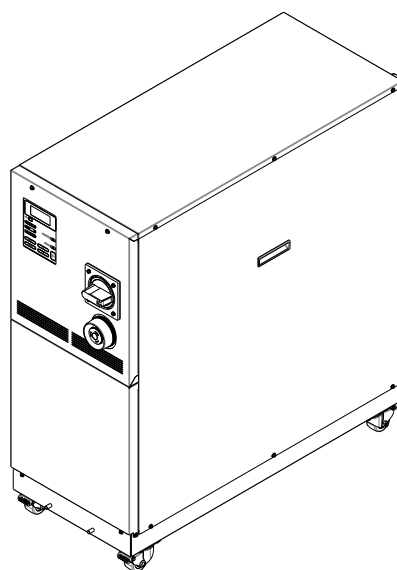

SMC Corporation



To the Customers

Thank you for purchasing our THERMO CHILLER HRZC Series (hereinafter called "This product").

For the long-term, safe use of this product, be sure to read and understand this manual thoroughly before performing operation of product.

- Warnings and precautions defined in this manual shall be observed.
- This manual provides the explanations of the installation and operation of this product. Only those who have thorough understanding of the fundamental operating procedure or have basic knowledge and skills of handling industrial equipment for the installation and operation of this product are qualified to perform installation and operation.
- The contents of this manual and related documents supplied with this product shall be neither regarded as a provision of the contract nor utilized to correct or modify the existing agreements, commitments and relations.
- Copying, duplicating or transferring any part of or whole contents of this manual without the prior written consent of SMC Corporation is strictly prohibited.
- The Service Manual is supplied in addition to this manual and provides the explanations of the inspection, troubleshooting, and in-depth remedies of this product. The Service Manual is intended for service personnel that completed service training, which SMC provides. Only those who fall under the above condition are allowed to perform maintenance and repair of this product with the use of the Service Manual.

Note: The contents of this manual are subject to change without notice.

Table of Contents

Chapter 1 Safety	1-1
1.1 Before Using This Product	1-1
1.2 Compliance Requirements	1-1
1.3 Danger, Warning, and Caution Used in This Manual	1-3
1.3.1 Hazard Levels	1-3
1.3.2 Definitions of “Serious injury” and “Minor injury”	1-3
1.3.3 Symbols.....	1-4
1.4 Hazard Warning Label	1-5
1.4.1 Type of hazard warning label	1-5
1.4.2 Location of hazard warning label	1-7
1.5 Location of Model Label	1-10
1.6 Safety Measures	1-11
1.6.1 Safety precautions.....	1-11
1.6.2 Safety Interlock system	1-12
1.6.3 Lockout/Tagout.....	1-13
1.6.4 Protective equipment.....	1-15
1.7 Emergency Measures	1-16
1.7.1 Emergency off [EMO] switch	1-16
1.8 Waste Disposal	1-18
1.8.1 Disposal of compressor oil	1-18
1.8.2 Circulating fluid disposal.....	1-18
1.8.3 System disposal	1-18
1.9 Safety Data Sheet (SDS)	1-19
Chapter 2 Name of Each Section	2-1
2.1 Name of Each Section	2-1
Chapter 3 Transporting and Installation	3-1
3.1 Transporting	3-1
3.1.1 Transporting with forklift	3-2
3.1.2 Transporting with caster	3-3
3.2 Installation	3-3
3.2.1 Installation conditions	3-4
3.2.2 Installation location and maintenance work area	3-5
3.3 Procedure for Installation	3-6
3.3.1 Installation	3-6
3.3.2 Procedure for system securing	3-6
3.3.3 Wiring installation	3-7
3.3.4 Procedures for wiring installation	3-9

Table of Contents

3.3.5 Installation of circulating fluid and facility water piping 3-13

Chapter 4 System Startup and Shutdown 4-1

4.1 Pre-check..... 4-1

4.1.1 Installation condition 4-1

4.1.2 Cable connection 4-1

4.1.3 Installation of circulating fluid and facility water piping 4-1

4.1.4 Operating signal from customer system 4-1

4.1.5 Check emergency off [EMO] switch 4-1

4.2 Opening of Facility water Valve 4-1

4.3 Filling of Circulating Fluid 4-2

4.3.1 Preparation of circulating fluid 4-2

4.3.2 Filling of circulating fluid..... 4-3

4.4 Requirement for System Startup 4-4

4.4.1 Turning ON power..... 4-4

4.4.2 Circulating fluid temperature setting 4-5

4.5 System Startup and Shutdown 4-5

4.5.1 System startup..... 4-5

4.5.2 System shutdown 4-5

Chapter 5 System Operation..... 5-1

5.1 Operation Display Panel..... 5-1

5.2 Flow Chart of Operation Screen..... 5-2

5.3 Operation Screen 5-4

5.3.1 Model Indication screen 5-4

5.3.2 Status screen 1 5-5

5.3.3 Status screen 2 5-6

5.3.4 Status screen 3 5-7

5.3.5 Status screen 4 5-8

5.3.6 Alarm Display screen 5-9

5.3.7 Menu screen 5-9

5.3.8 Setting screen 5-10

5.3.9 Control Setting screen 1 5-11

5.3.10 Control Setting screen 2 5-12

5.3.11 Control Setting screen 3-1 5-13

5.3.12 Control Setting screen 3-2 5-14

5.3.13 Alarm Setting screen 1 5-15

5.3.14 Alarm Setting screen 2 5-16

5.3.15 Alarm Setting screen 3 5-17

5.3.16 Initial Setting screen 1 5-18

5.3.17 Initial Setting screen 2 5-19

5.3.18	Initial Setting screen 3	5-20
5.3.19	Initial Setting screen 4	5-21
5.3.20	Initial Setting screen 5	5-22
5.3.21	Initial Setting screen 6	5-23
5.3.22	Initial Setting screen 7	5-24
5.3.23	Initial Setting screen 8	5-25
5.3.24	Mode Selection screen.....	5-26
5.3.25	Maintenance screen 1	5-27
5.3.26	Maintenance screen 2	5-28
5.3.27	Maintenance screen 3	5-29
5.3.28	Maintenance screen 4	5-30
5.3.29	Maintenance screen 5	5-31
5.3.30	Maintenance screen 6	5-32
5.3.32	Maintenance screen 7	5-33
5.3.33	Maintenance screen 8	5-34
5.3.34	Maintenance screen 9	5-35
5.3.35	System Information screen.....	5-36
5.4	Examples of System Operation.....	5-37
5.4.1	Example 1: Circulating fluid set temperature is changed from 20.0 deg C to 34.1 deg C.....	5-37
5.4.2	Example 2: Communication mode is switched from "LOCAL" to "SER REMOTE".....	5-39
5.4.3	Example 3: PUMP IV is switched from "FLOW" to "FREQ".	5-40
Chapter 6	Error Message and Troubleshooting.....	6-1
6.1	Error Message	6-1
6.2	Troubleshooting	6-2
Chapter 7	System Maintenance	7-1
7.1	Water Quality Management.....	7-1
7.2	Inspection and Cleaning	7-2
7.2.1	Daily inspection	7-2
7.2.2	Quarterly inspection	7-3
7.3	Storage.....	7-3
7.3.1	Draining of circulating fluid out of tank	7-4
7.3.2	Draining of facility water	7-5
7.4	Periodic Replacement Parts	7-6
Chapter 8	Appendix	8-1
8.1	Specification.....	8-1
8.1.1	System specification.....	8-1
8.1.2	Cooling capacity	8-4
8.1.3	Heating capacity.....	8-6
8.1.4	Pump Performance Curve.....	8-8

Table of Contents

8.1.5 Communication specification 8-10

8.1.6 Alarm signal selection 8-13

8.2 Outer Dimensions 8-14

8.3 Flow Chart 8-15

8.4 Offset Function 8-16

8.4.1 Example of offset function 8-17

8.5 BAND/READY function 8-19

8.6 Anchor Bolt Mounting Position 8-20

8.7 Compliance 8-21

8.8 Thermo Chiller Daily Inspection Sheet 8-22

Chapter 9 Limited warranty and Disclaimer/ Compliance Requirements 9-1

Chapter 1 Safety



Be sure to read and understand the important precautions defined in this manual thoroughly prior to system use.

1.1 Before Using This Product

- This "Safety" chapter describes the safety-related items that users should be aware of upon handling this product.
- This product, which is operated under high voltage, is outfitted with the parts that cause a rise or drop in temperature and rotating parts when it is in action. All personnel who work with or around this product are required to thoroughly read and understand the safety-related items in this manual prior to working with or around this product.
- This manual is not intended to be used as a manual for comprehensive safety and hygiene education. Such a manual should be provided by a safety training manager.
- The product is operated at high voltage and contains components which become hot and rotate. If a component needs to be replaced or repaired, contact a specialized vendor for parts and service.
- A safety manager is responsible for observing safety standards. Operators and maintainers, however, are to have individual responsibilities for complying with the safety standard in his/her daily work.
- Operators and maintainers must individually take account of safety and assure a proper working area and working environment.
- The relevant personnel must receive proper safety education prior to work training on this product. Otherwise, personnel may be exposed to hazards. Never conduct work training without giving proper consideration to safety.
- Do not use the materials that rust or corrode for the circuits for circulating fluid and facility water. Using the materials that tend to rust or corrode may cause clogs and/or leakages of the these circuits. In case of using these kind of materials, consider and carry out some prevention against the rusting or corrosion on the customer side.
- Save this manual at a designated place for reference when necessary.

1.2 Compliance Requirements

The use of SMC products with production equipment for the manufacture of weapons of mass destruction (WMD) or any other weapon is strictly prohibited. The exports of SMC products or technology from one country to another are governed by the relevant security laws and regulations of the countries involved in the transaction. Prior to the shipment of a SMC product to another country, assure that all local rules governing that export are known and followed.

⚠ WARNING



- The compatibility of the product is the responsibility of the person who designs the equipment or decides its specifications. Since the product specified here is used under various operating conditions, its compatibility with specific equipment must be decided by the person who designs the equipment or decides its specifications based on necessary analysis and test results. The expected performance and safety assurance of the equipment will be the responsibility of the person who has determined its compatibility with the product. This person should also continuously review all specifications of the product referring to its latest catalog information, with a view to giving due consideration to any possibility of equipment failure when configuring the equipment.

- Only personnel with appropriate training should operate machinery and equipment. The product specified here may become unsafe if handled incorrectly. The assembly, operation and maintenance of machines or equipment including our products must be performed by an operator who is appropriately trained and experienced.

- Our products cannot be used beyond their specifications. Our products are not developed, designed, and manufactured to be used under the following conditions or environments. Use under such conditions or environments is not covered.

1. Conditions and environments outside of the given specifications, or use outdoors or in a place exposed to direct sunlight.
2. Use for nuclear power, railways, aviation, space equipment, ships, vehicles, military application, equipment affecting human life, body, and property, fuel equipment, entertainment equipment, emergency shut-off circuits, press clutches, brake circuits, safety equipment, etc., and use for applications that do not conform to standard specifications such as catalogs and operation manuals.
3. Use for interlock circuits, except for use with double interlock such as installing a mechanical protection function in case of failure.

Please periodically inspect the product to confirm that the product is operating properly.

CAUTION



We develop, design, and manufacture our products to be used for automatic control equipment, and provide them for peaceful use in manufacturing business.

Use in non-manufacturing business is not covered.

Products we manufacture and sell cannot be used for the purpose of transactions or certification specified in the Measurement Act.

The new Measurement Act prohibits use of any unit other than SI units in Japan.

1.3 Danger, Warning, and Caution Used in This Manual

1.3.1 Hazard Levels

This product is designed with its first priority being the safety of workers and the prevention of system damage. This manual classifies the risks into the following three categories according to the severity and level of the hazard: Danger, Warning, and Caution. Read the statements carefully, thoroughly understand them before operating this product.

DANGER, WARNING and CAUTION signs are in order according to hazard severity (DANGER > WARNING > CAUTION). See below for the details.

DANGER

"DANGER" denotes that there is an imminent hazard which will cause serious personal injury or death during operation.

WARNING

"WARNING" denotes that there is a hazard which may cause serious personal injury or death during operation.

CAUTION

"CAUTION" denotes that there is a hazard which may cause minor personal injury during operation.

CAUTION

"CAUTION" without an exclamation symbol denotes that there is a hazard which may cause damage or failure of this product, facility, or devices.

[Tips]

Tips are provided when there is information that personnel are required to be aware of for system operation and maintenance. If the task carries useful information, the relevant tips are given as well.

1.3.2 Definitions of “Serious injury” and “Minor injury”

■ “Serious injury”

This term describes injuries such as loss of eyesight, wound, burns, frostbite, electric shock, fracture, and toxication that leave aftereffects, and/or injury requiring hospitalization and/or prolonged staying in a hospital.

■ “Minor injury”

This term describes injuries that do not require hospitalization or prolonged staying in a hospital (injuries other than “serious injuries” described above).

1.3.3 Symbols

This manual provides the following symbols in addition to “Danger”, “Warning”, and “Caution” to present the warning details in easy-to-understand manner.

■ Symbol of electrical hazard

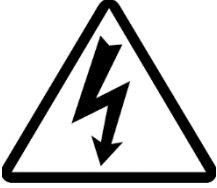

This symbol warns you of potential electrical shock.

■ Symbol of heat hazard



This symbol warns you of potential burns.

■ Symbol of low temperature hazard



This symbol warns you of potential frostbite.

■ Symbol of “Prohibited”



This symbol denotes “Prohibited” actions during the operation of this product.

■ Symbol of “Required Action”



This symbol denotes the “obligation” items which you must follow in operation of this product.

1.4 Hazard Warning Label

The hazard warning labels are applied to the sections of this product where potential hazards are present during system operation and maintenance.

The hazard warning labels are in appropriate sizes and colors to get attention of the operator.

They contain symbols in addition to the descriptions of warnings.

1.4.1 Type of hazard warning label

The hazard warning labels affixed on this product are listed below.

■ Labels of high voltage hazard

[High voltage hazard]

This warning label is affixed on the part isolated with the cover panel of the system panel in which high voltage is applied.

Do not remove cover panels that are not designated in this manual.



Figure 1-1 Hazard warning label No.1



Figure 1-2 Hazard warning label No.2



Figure 1-3 Hazard warning label No.3

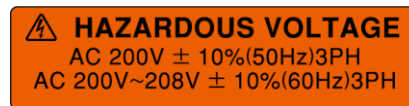

Figure 1-4 Hazard warning label No.4

■ Labels of hot/cold surface hazard

[Hot/cold surface hazard]

This warning label is affixed on the surface that is at high or low temperatures carrying potential burns (or frostbite) if touched. Residual heat may cause burns despite the power being turned OFF. Be sure of the surface reaching room temperature before work.



Figure 1-5 Hazard warning label No.5

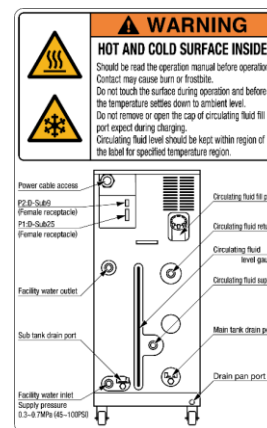

Figure 1-6 Hazard warning label No.6

■ Labels of high pressure refrigerant hazard

[High pressure refrigerant hazard]

The system contains refrigerant under high pressure. Do not tamper with the system. It must be serviced by suitably qualified persons only.



Figure 1-7 Hazard warning label No.7



Figure 1-8 Hazard warning label No.8

1.4.2 Location of hazard warning label

⚠ WARNING

 Do not peel off or deface the hazard warning labels.

⚠ WARNING

 Confirm the locations of the hazard warning labels. Read the contents of the hazard warning labels carefully and keep them in mind. Users are NOT allowed to change the locations of the hazard warning labels. Make sure to affix a new label to exactly the same location of the replaced label upon replacement of the peeled off or worn out label.

■ High voltage hazard

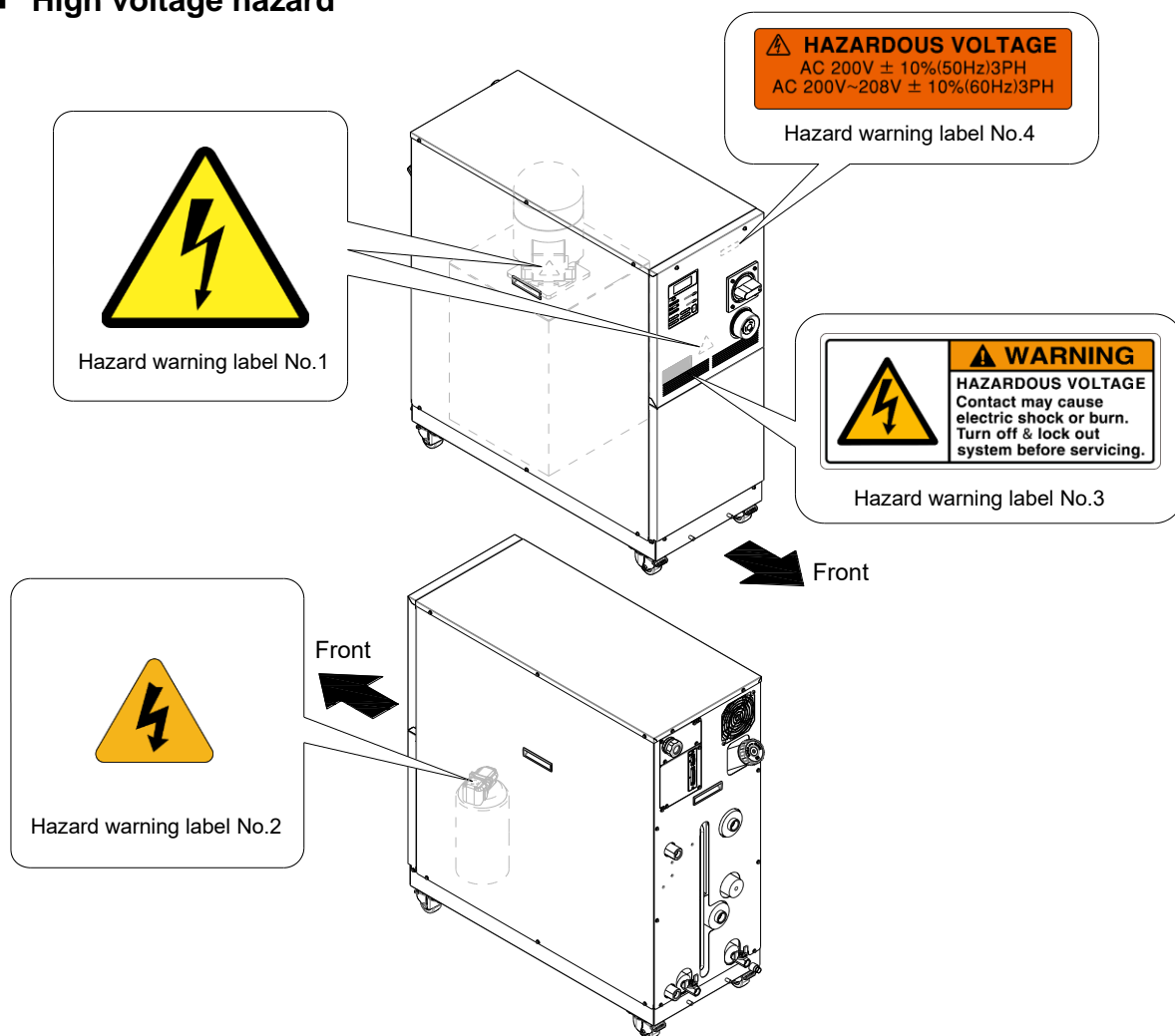

Figure 1-9 High Voltage Hazard

■ **Hot/cold surface hazard**

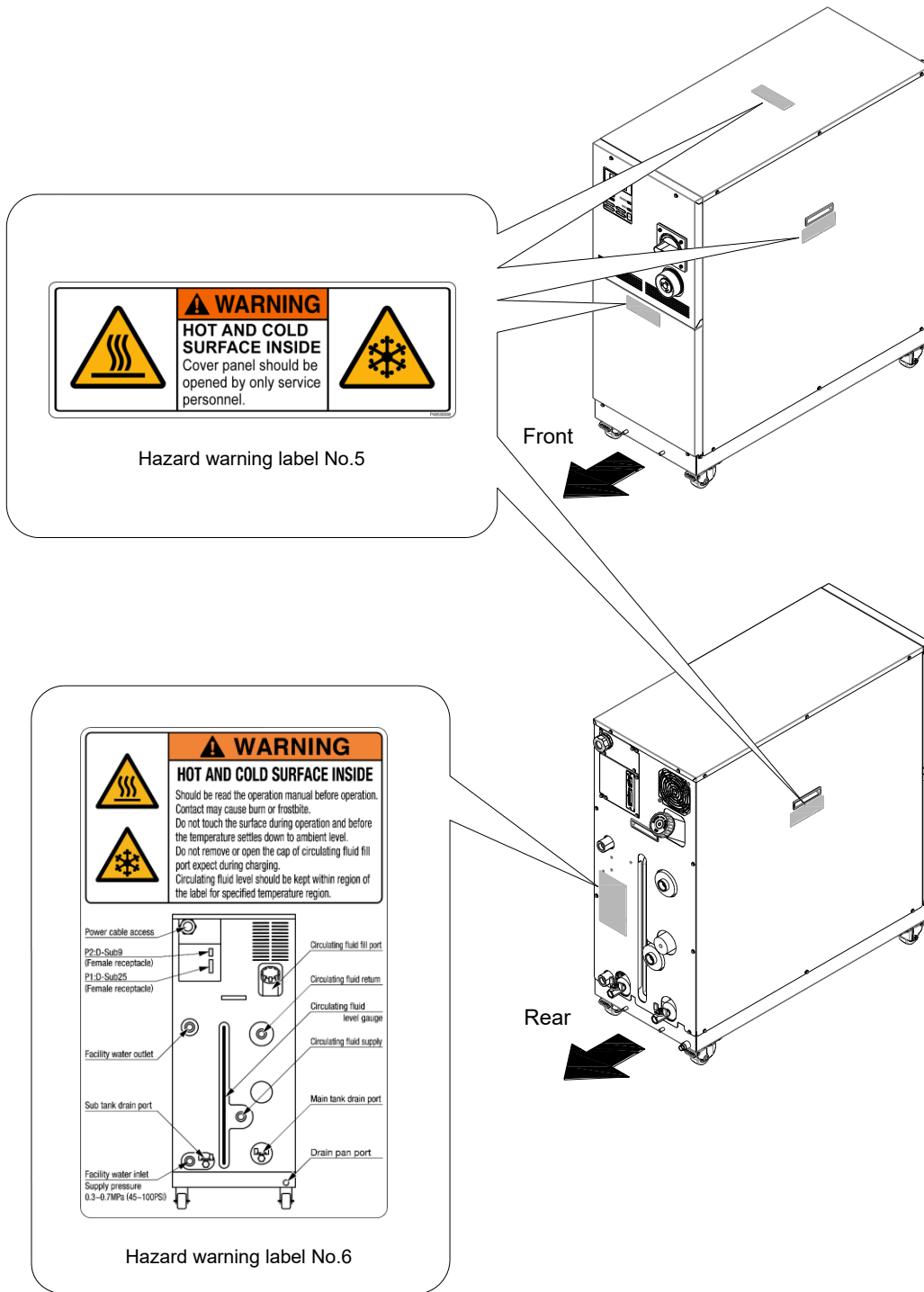

Figure 1-10 Hot/Cold Surface Hazard

■ High pressure refrigerant hazard

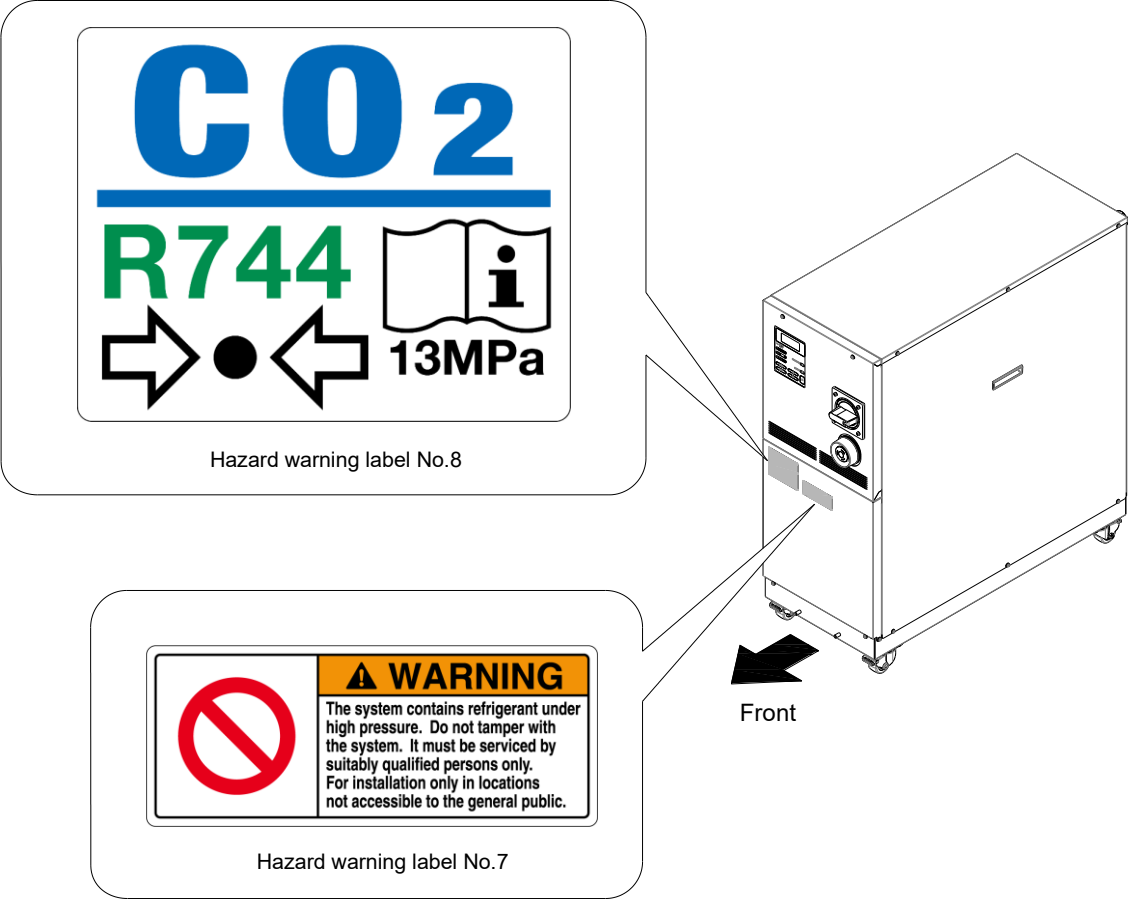

Figure 1-11 High pressure refrigerant hazard

1.5 Location of Model Label

Information about the product, such as Serial No. and Model No. can be found on the product label. This information is needed when contacting an SMC sales distributor.

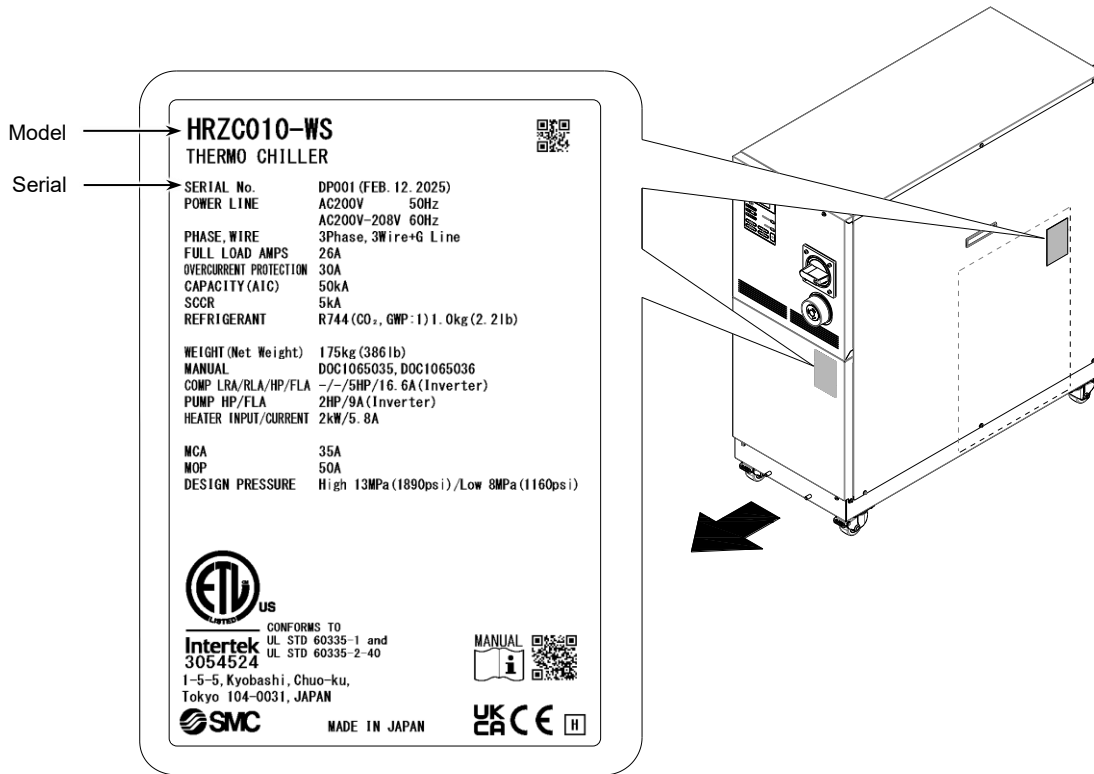

Figure 1-12 Location of Model Label

1.6 Safety Measures

1.6.1 Safety precautions

While this product is protected by various safety measures including the safety interlocks, the following basic safety precautions should be observed to assure further safe operations.

WARNING



Follow the instructions below upon operation of this product. Failure to follow the instructions can lead to personal injury or hazardous accidents.

- Read and understand this manual thoroughly before operation of this product.
- Before operating the system during maintenance, inform all personnel who are working in the vicinity of the system to alert them of your action.
- Use appropriate tools and follow proper procedures.
- See “1.6.4 Protective equipment” on page 1-15 to wear protective equipment properly.
- Refer to your safety manual for emergency evacuation.
- Use assistance to carry object over 20 kg.
- Check that all parts and screws are returned; fitted correctly and securely after maintenance.
- Do not work when intoxicated or feeling ill. Accidents may occur if disregarded.
- Do not remove a panel unless permitted in this manual.
- Do not handle this product by any means other than specified in this Operation Manual; this can result in damage to the product or fire.

1.6.2 Safety Interlock system

■ Safety Interlock system

The function of the safety interlock system is not only to protect personnel by restricting operation that may cause damage to this product or the facility around it, but also to eliminate the danger relating to safety. This product is outfitted with several interlock functions that are activated when improper operation or hazardous conditions occur. System operation shall be terminated when a safety interlock is activated.

An alarm message is displayed on the LCD screen when a safety interlock is activated. See “Chapter 6 Error Message and Troubleshooting” and on page 6-1 for details on the alarms and remedies or see section “Troubleshooting” in a separate volume of the “Service Manual”.

■ Front panel

Product repair may require the removal of the front panel.

The breaker handle operation is functional only with the front panel attached.

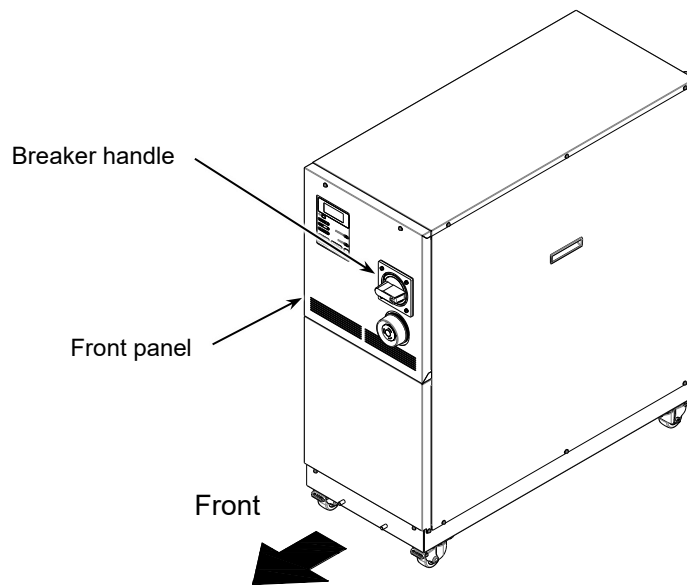

Figure 1-13 Front Panel

1.6.3 Lockout/Tagout

■ Summary

Lockout in this product disables the main breaker operation to prevent electric shocks. Tagout, to be placed on a locked out main breaker, to prevent improper breaker operation (ON) conducted by other personnel. See "Lockout procedure" in the following pages for practical lockout/tagout.

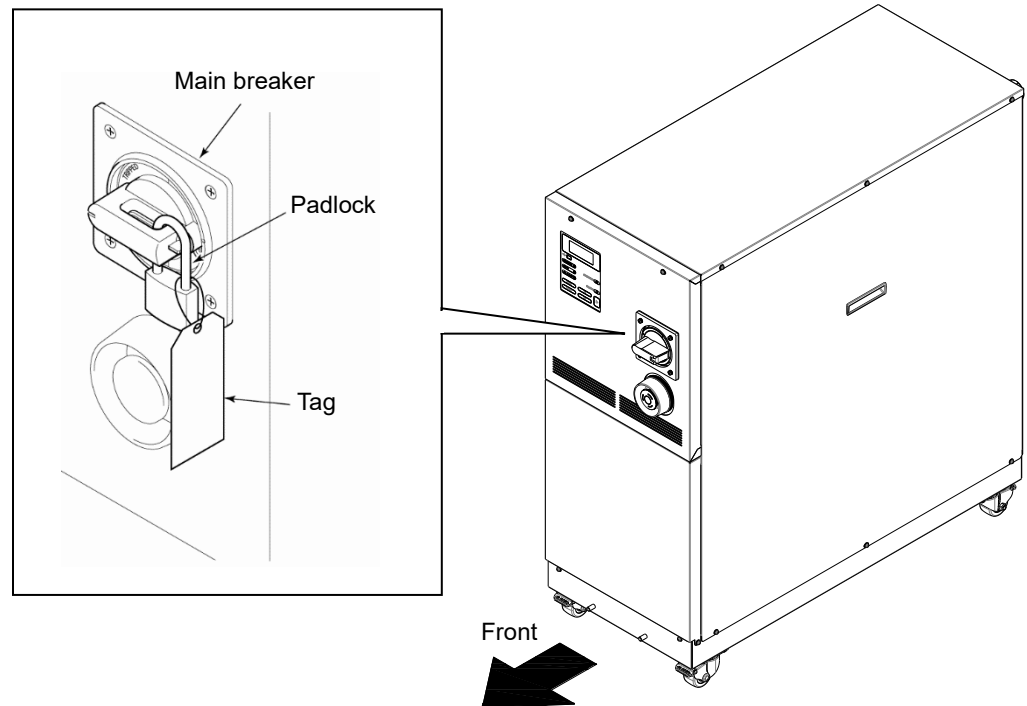

Figure 1-14 Lockout/Tagout

⚠ WARNING



Those who engage in service of this product should build an awareness of the importance of lockout. Thorough understanding of the procedures defined in this manual are required for system service. Lockout is allowed only when the system come to a full stop. A supervisor should be appointed to direct all personnel if multiple workers engage in system service. The supervisor is to perform lockout based on a full understanding of overall process conditions. Not only all personnel but new personnel that engage in service of this product should build an awareness of the importance of lockout and obtain thorough understanding of the lockout procedure. Any personnel working in an area with high voltage should be assigned with padlocks and tags. The key for the padlock is kept under the responsibility of the supervisor, and lockout release is performed upon completion of work.

■ Lockout procedure

⚠ WARNING



All service personnel must observe the restrictions applied during lockout and are required to perform lockout in accordance with this procedure. No service personnel is allowed to start, energize, or use the locked out system.

1. Turn the breaker handle to 'OFF ○'.

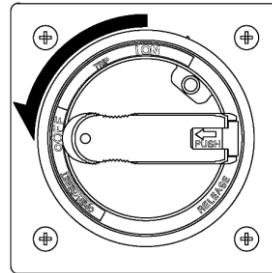

Figure 1-15 Breaker Handle at 'OFF ○'

2. Push the end face of the breaker handle and pull out the lock attachment.

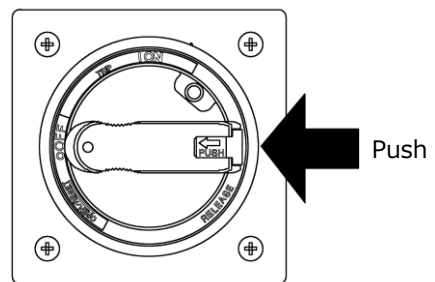

Figure 1-16 Breaker Handle at 'RESET'

3. Lock the lock mechanism part with the padlock.
The lock mounting does not close.

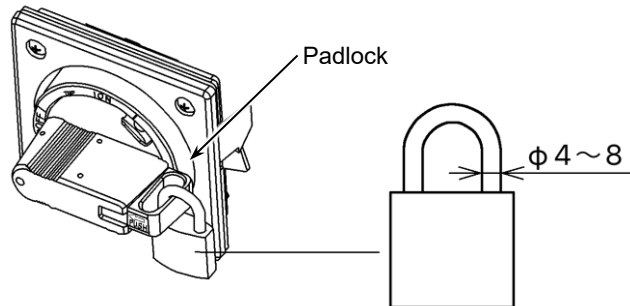



Figure 1-17 Pushing of Lock Mechanism Part

■ Releasing lockout

1. Remove the padlock from the lock mechanism part.
-
2. Push the end face of the breaker handle and return the lock mounting.
The lock mounting part closes.

1.6.4 Protective equipment

This manual defines protective equipment according to work type.
Wear proper protective equipment as shown below, according to work type.

 **WARNING**



Read and understand the relevant operation manual thoroughly prior to use of protective equipment.

■ For system transportation, installation and removal

- Protective footwear
- Protective gloves
- Hard hat

■ For handling circulating fluid

- Protective footwear
- Protective gloves
- Protective mask
- Protective apron
- Protective goggles

■ For system operation

- Protective footwear
- Protective gloves

1.7 Emergency Measures

1.7.1 Emergency off [EMO] switch

Press the red EMO switch on the front of the system only if the need to shut off the power arises due to emergency such as natural disaster, fire, earthquake, or personal injury.

The EMO switch is a large, red mushroom-shaped push button labeled with 'EMO' on it. The system stops running if this button is pressed.

When the EMO switch pressed, the control power for this product is shut off to bring the system to a stop. The main breaker of this product, however, is designed not to trip, which enables the motor circuit to remain partially energized. "8.1.5 Communication specification" in Chapter 8 Appendix on page 8-10 to view the circuit diagram and see how the EMO switch is interconnected to the system.

Restarting of this product is enabled only when this button is reset manually.

■ Location of emergency off [EMO] switch

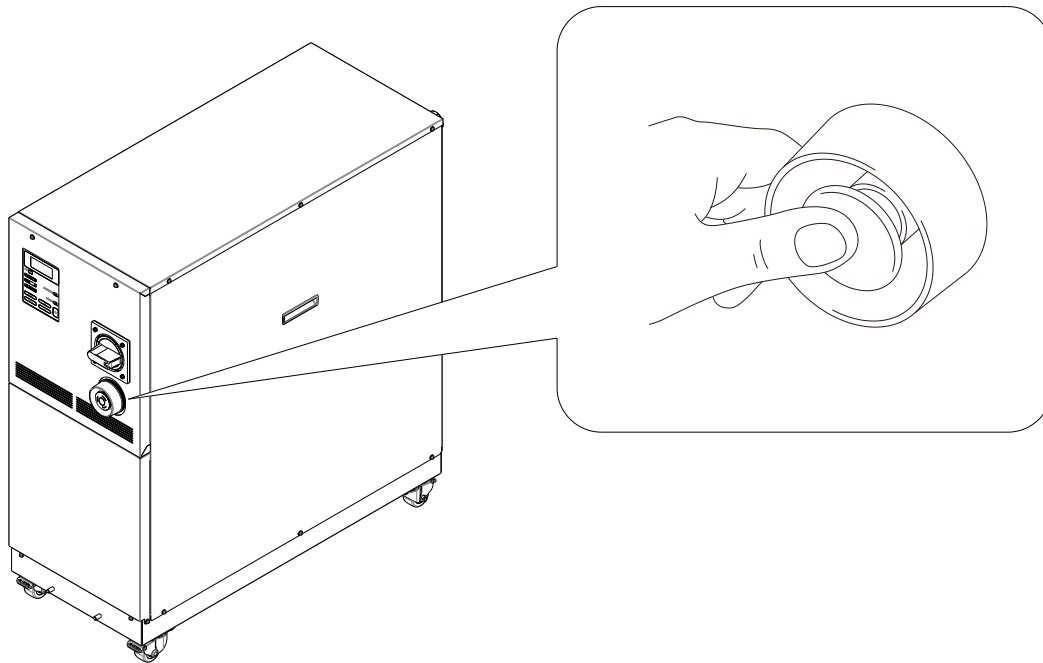



Figure 1-18 Location of Emergency Off [EMO] Switch

■ Reset of emergency off [EMO] switch

⚠ WARNING

 **No automatic recovery is applied to the emergency off [EMO] switch. Always eliminate the cause of activating the EMO before resetting. Potential serious accidents may occur if disregarded.**

1. Before restarting, always make sure that the cause of the emergency off condition (The reason why the EMO switch was activated) has been eliminated from the power supplies, the product, and peripheral equipment.

2. With the cause completely eliminated, turn the EMO switch clockwise to reset.

The EMO button returns to its original position.

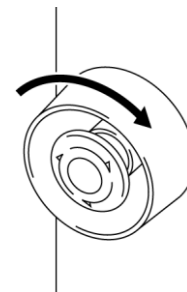



Figure 1-19 Emergency Off [EMO] Switch

⚠ WARNING

 **When the product is in remote mode, the remote mode is retained despite the power outage. Thus the system operation is to resume as the start signal is issued from customer's system.**

3. The screen then changes from the "Model Indication screen" to "Status screen 1" as power is being restored to the product.

1.8 Waste Disposal

1.8.1 Disposal of compressor oil

The product uses compressor oil. If they need to be recovered, read and understand the instructions below carefully. If there is any unclear point, contact an SMC's sales distributor.

WARNING



Only service personnel or those who are qualified are allowed to open the panel of this product.
Do not dispose of the compressor oil as domestic garbage.
Incineration is permitted only at an authorized incinerator.
The refrigeration circuit of this product is in a high pressure state, so do not modify it.
Contact knowledgeable service personnel before disposal.

WARNING



Disposal of the compressor oil must be in accordance with regulations and rules of local authorities.
Only personnel with proper licensing, who have adequate knowledge and experiences with not only this product but associated equipment,

[Tips]

For the type and quantity of the refrigerant, See "Location of Model Label" on page 1-10.

1.8.2 Circulating fluid disposal

The disposal of the circulating fluid (ethylene glycol solution, fluorinated fluid) must be handled by a specialized industrial waste disposal agency with the contents detailed.

1.8.3 System disposal

The disposal of the product must be handled by a specialized industrial waste disposal agency in accordance with local laws and regulations.

1.9 Safety Data Sheet (SDS)

Any chemicals used by the user must be accompanied by an SDS.

■ **Galden® HT 135 and Galden® HT 200**

Website : <https://www.solvay.com/en/>

■ **Fluorinert™ FC-3283 and Fluorinert™ FC-40**

Website : <https://www.3m.com/>

■ **60% Ethylene glycol aqueous solution**

Please contact our sales department.

WARNING



[About Contents]

Contents documented here are based on references, information and data available so far. Information given regarding physical/chemical properties, hazard and toxicity here gives no guarantee.

Also, be noted that cautions are for normal handling. Carry out sufficient safety, hygiene, and environmental measures for special handling.

Note the items described as “no documentation” mean our study on those items is not completed yet.

Chapter 2 Name of Each Section

2.1 Name of Each Section

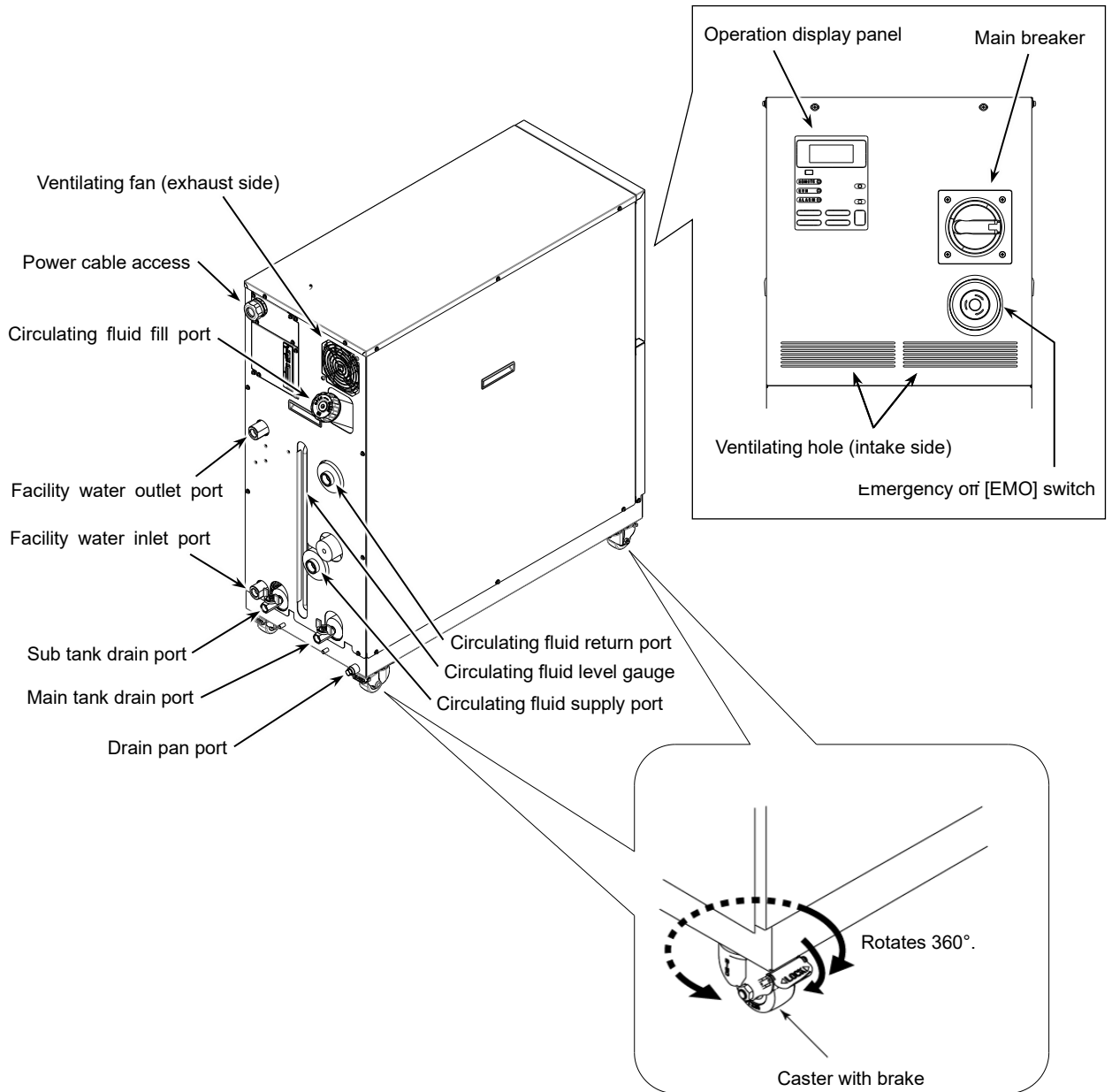

Figure 2-1 Name of Each Section

[Tips]

The casters have built-in brakes. The disengagement of the brakes is required when transporting the product.

Chapter 3 Transporting and Installation

WARNING



Proper procedure must be followed when using this product. Exercise caution to assure personnel safety during the installation, operation, maintenance, and inspection of the system. Only personnel, who have adequate knowledge and experiences with not only this product but associated equipment, are allowed to perform transport, installation, and maintenance involving potential hazardous task.

3.1 Transporting

This product is heavy, which poses potential danger during transportation.

When transporting this product, the following safety precautions should be followed to prevent system damage and breakdown.

WARNING



For transporting with the forklift, be sure to insert the fork into a designated position, referring to “3.1.1 Transporting with forklift” on page 3-2.

CAUTION



Do not set this product on its side during transportation. Oil in the compressor will drain into the refrigerant pipe, which causes lubricant shortages leading to damage to the compressor.

CAUTION



Drain the remaining fluid out of the pipe as much as possible. The remaining fluid may spill if disregarded. Exercise caution not to damage the panel and piping with the forklift when transporting the system.

3.1.1 Transporting with forklift

⚠ WARNING

 Do not set this product on its side for transportation. If disregarded, there is potential damage to the system, damage to the forklift, and danger of injury to personnel.
Do not insert the fork from the back as well as front.

⚠ WARNING

 This product is heavy and requires a forklift to safely move it. Forklift insertion positions are on either left or right side of this product. Always insert the forks all the way through. Be careful not to hit the casters.

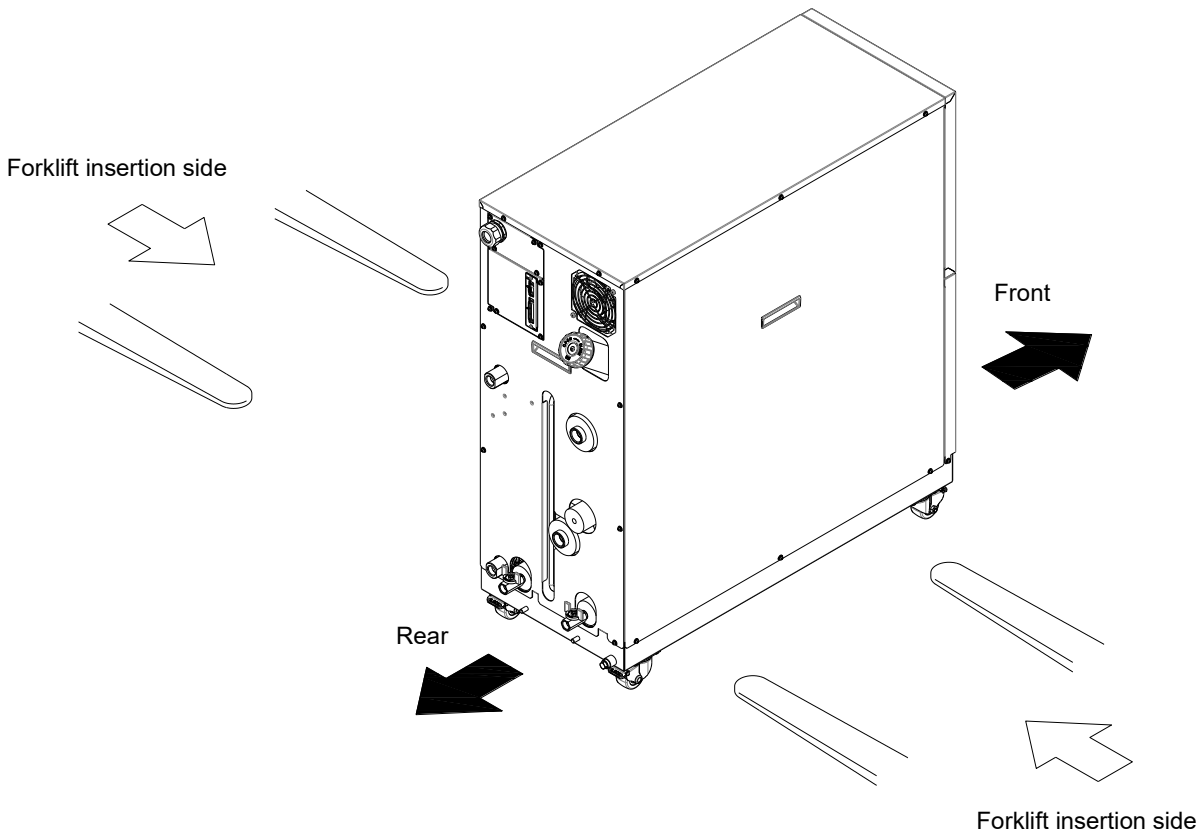

Figure 3-1 Transport with Forklift

3.1.2 Transporting with caster

WARNING



This product is heavy, which requires assistance for this work. Exercise caution and look out for sloped surfaces such as ramps, etc.

CAUTION



Do not grab piping on the back of this product or panel handles when transporting with the casters. Potential damage to piping and panels may occur if disregarded.

3.2 Installation

WARNING



System installation should be kept from areas with the potential of flammable gas leaks. Ignition may occur if leaked gas is collected around the product.

This product is NOT designed for outside use.

Potential electric shock, fire and system damage may occur if exposed to rain, water and dust.

CAUTION



This product is to be installed on a level floor that can withstand the weight of this product. Potential water leak and personal injury due to system tipping over may occur if disregarded.

3.2.1 Installation conditions

The product installation is not allowed outside or in the conditions described below.

Potential system malfunction and damage may occur if disregarded.

Clean room specifications are not applied to this product. The pump and ventilating fan installed in this product generate particles.

- Location that is exposed to water vapor, salt water, and oil
- Location that is exposed to dust and powder
- Location that is exposed to corrosive gas, solvent, and flammable gas
- Location that is exposed to direct sun light or radiant heat
- Location where ambient temperature is out of the following range:
 - In operation 10 to 35 deg C
 - In storage 0 to 50 deg C (with no water or circulating fluid in piping)
- Location where an ambient humidity is out of the following range:
 - In operation 30 to 70%
 - In storage 15 to 85%
- Location that is subjected to abrupt changes in temperature
- Location that is subjected to intense electromagnetic noise (intense electric field, intense magnetic field, or surges)
- Location that is subjected to static electricity, or condition that discharges static electricity to the system
- Location that is subjected to strong high frequencies
- Location that is subjected to potential lightning damage
- Location with altitudes of 1000m or higher
- Location that is affected by strong vibrations or impacts
- Condition that applies external force or weight causing the product deformation.
- Condition with no adequate space for maintenance as required in the installation site.
- Location that is inclined.
- Location accessible to the general public.

3.2.2 Installation location and maintenance work area

This product does not have ventilating holes on the right and left sides. Although this can be installed directly contacting to walls or devices, installation with maintenance space is recommended. (See "Figure3-2)

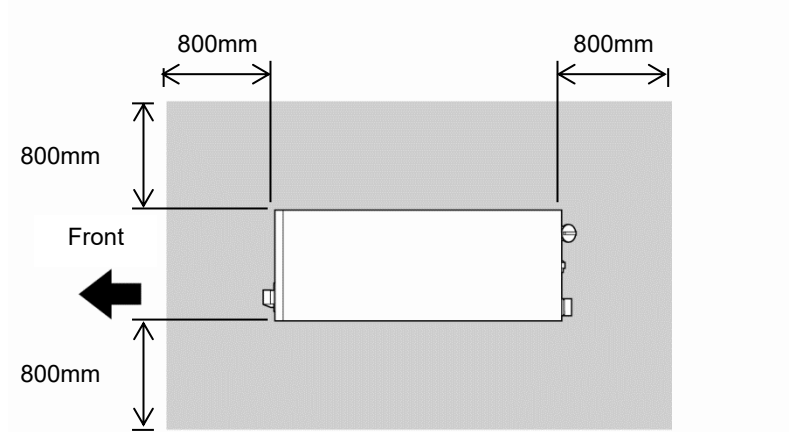

Figure 3-2 Recommended Installation Location

To save space, this product can be installed to allow access only in front and back for daily operation and inspection. For maintenance and repair work, additional access space is required for the left and right side of the product. We recommend a separate repair area, without taking space from installation site, to accommodate the needed extra space.

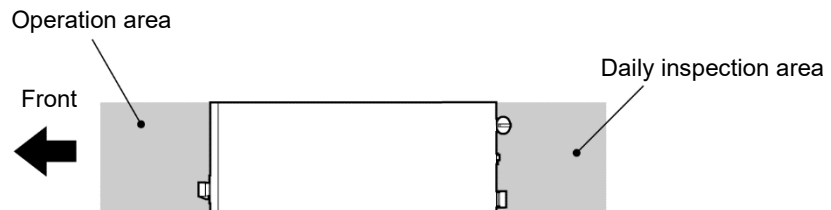

Figure 3-3 Installation Location

3.3 Procedure for Installation

CAUTION

Anti-quake bracket is an optional part, which is required for the installation of this product (HRZ-TK002). Preparation of anchor bolts suitable for floor material is your responsibility. M12-anchor bolts (4 pcs.) needed. See “Appendix 8.6 Anchor Bolt Mounting Position ”on page 8-20.

3.3.1 Installation

- The product installation should be on a vibration-free stable level plane.
- See “Appendix 8.2 Outer Dimensions” in Chapter 8 on page 8-14 for the dimensions of this product.

3.3.2 Procedure for system securing

1. Transfer this product to the installation site.

2. Lock the brakes on casters.

3. Using a 13-mm open end wrench, attach the anti-quake brackets to the front and back.

CAUTION

Drain pan port is assigned to the bottom on the back of this product. Exercise caution not to damage the drain pan port when attaching the anti-quake bracket.

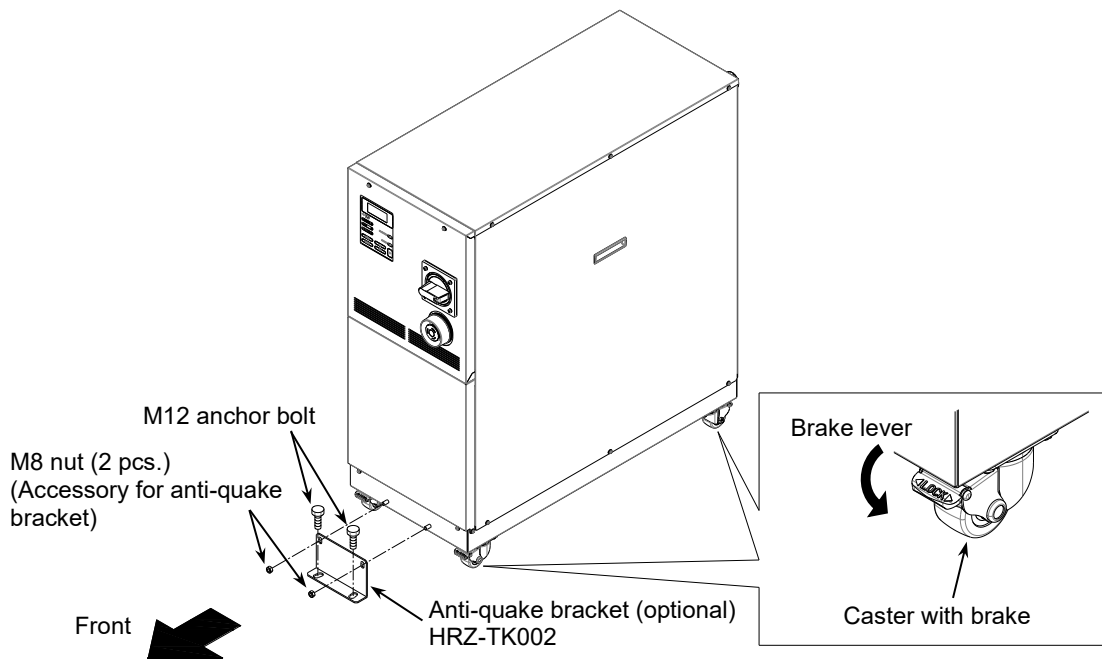

Figure 3-4 Anti-quake Bracket Attachment

3.3.3 Wiring installation

⚠ **WARNING**

Only designated personnel are allowed to install wiring. Be sure to turn OFF the power prior to wiring to assure safety. Do not do any wiring when the system is energized. The system wiring requires a thorough and secure connection with the designated cable to prevent a loose connection. Poor connection and securing may cause electric shock, heat sports, fire or communication errors.

Be sure to supply the power to this product according to specifications. Supply pure AC power. Potential malfunction may occur if a rectified AC with voltage rise (dv/dt) at zero crossing exceeds 40V/200µ sec. Always establish a connection to a ground for safety. Be sure that no ground connection is made to a water pipe, gas pipe, and lighting rod.

Voltage
dV
dt
Voltage rise %
Time

■ Power cable

The power cables are to be prepared under your responsibility, referring to the following table.

Table 3-1 Power Cable and Main Breaker (This product)

Item		HRZC002-WS HRZC002-W1S HRZC002-W2S	HRZC004/008-WS HRZC004/008-W1S HRZC004/008-W2S	HRZC010-WS HRZC010-W1S HRZC010-W2S
Power cable	Size (recommended)	10AWG×4-conductor		
	Crimp contact (recommended)	Breaker	R5.5-5	
		Earth bar	R5.5-8	
	Torque (recommended)	Breaker	2.5N•m (1.84 ft-lbf)	
Earth bar		12.5N•m (9.22 ft-lbf)		
Main breaker (This product)		20A	30A	

■ Communication connector

The communication connectors are to be prepared under your responsibility, referring to the following table.

Table 3-2 Communication Connector

Connector	Type (for customer side)
Contact signal (P1 connector)	D-Sub 25-pin (male)
Serial RS-485 (P2 connector)	D-Sub 9-pin (male)

■ Selection of the breaker for the customer's equipment (primary side)

⚠ CAUTION



This product is equipped with the breaker which has different operating characteristics depending on each model. For the customer's equipment (primary side), use the breaker whose operating time is equal to or longer than the breaker of this product. If the breaker with shorter operating time is connected, the customer's equipment could be cut off due to the inrush current of the motor of this product.

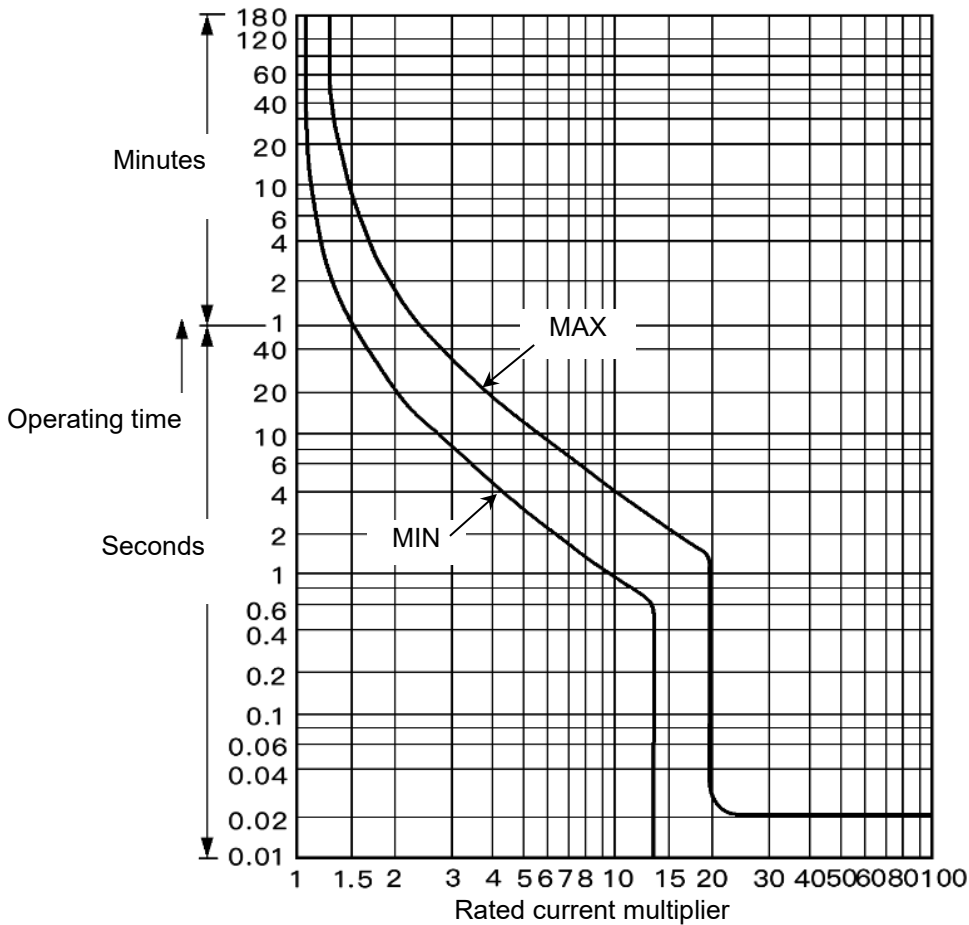

Figure 3-5 Breaker operating characteristics curve

3.3.4 Procedures for wiring installation

⚠ WARNING



Be sure to turn OFF the factory side (primary side) power before connection to this product.
Use the assigned procedure to perform lockout/tagout (Page 1-13).

1. Turn OFF the power breaker on customer side (primary side), and then use the assigned procedures to perform lockout/tagout.

[Tips]

Connection of the power cable with this product must be established first.
Do not connect the cable with the factory side at this point.

2. Turn OFF the main breaker of this product.

3. Undo the screws (2 pcs.) to remove the front panel.

Be sure to use a Phillips screwdriver.

4. Undo the screws (2 pcs.) or press claw to remove the breaker cover.

Be sure to use a Phillips screwdriver.

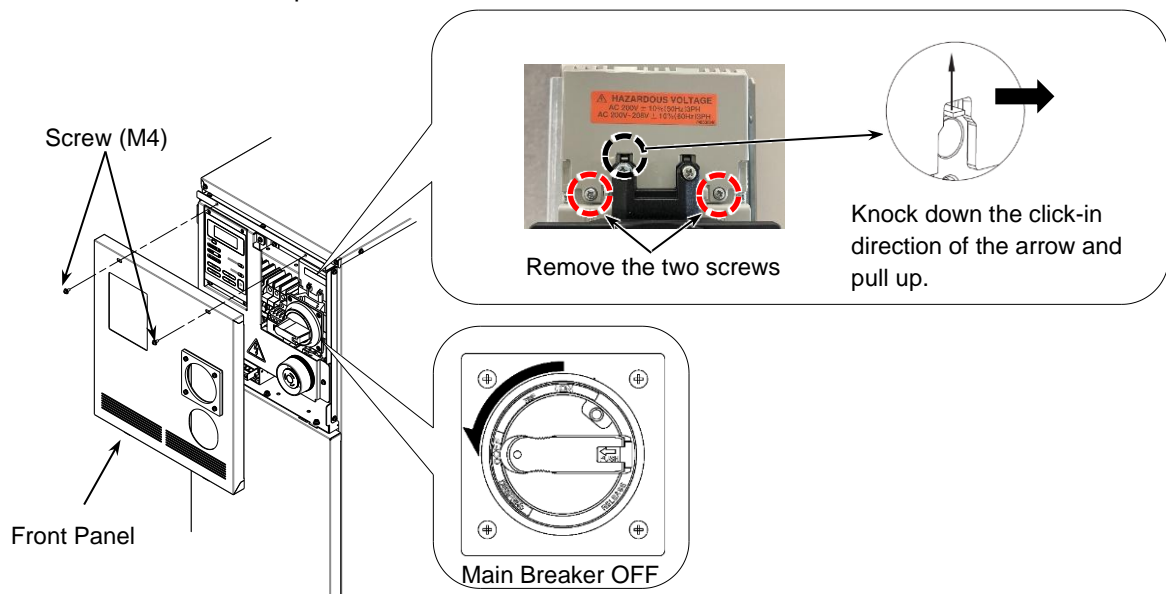

Figure 3-6 Main Breaker OFF and Removal of Front Panel/Breaker Cover

[Tips]

Make sure the breaker is at the 'OFF' position.
Otherwise, the removal of the front panel is not possible.

5. Loosen the cap at power cable access (strain relief) and insert the power cable.

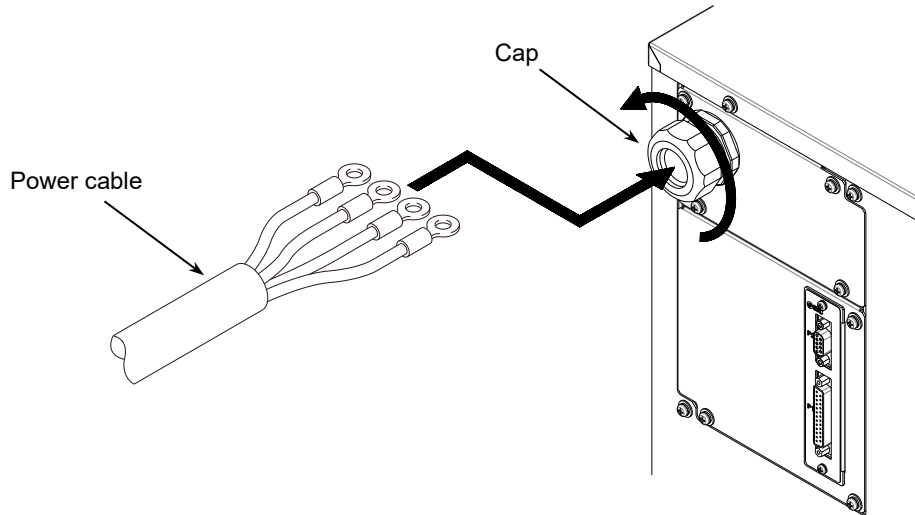

Figure 3-7 Power cable insertion

CAUTION



Correct phase rotation is required when attach the power cable to the breaker terminal.
Do not drop a screw or washer in the electrical unit when attaching the breaker cover and terminal.
Do not leave it in the unit if dropped in. Potential failure may occur if the power is turned ON without removing it.

[Tips]

See “Table 3-1 Power Cable and Main Breaker (This product)” on page 3-7 for the recommended cable size and crimp contact.

6. Connect the power cables to the breaker terminal.

Be sure to use a Phillips screwdriver. See Table 3-1 on Page 3-7 for recommended torque.

7. Connect the grounding terminal (M8) of the power cable to the earth bar.

Be sure to use a 13-mm open end wrench.
Recommended torque: 12.5 N•m (9.22 ft-lbf)

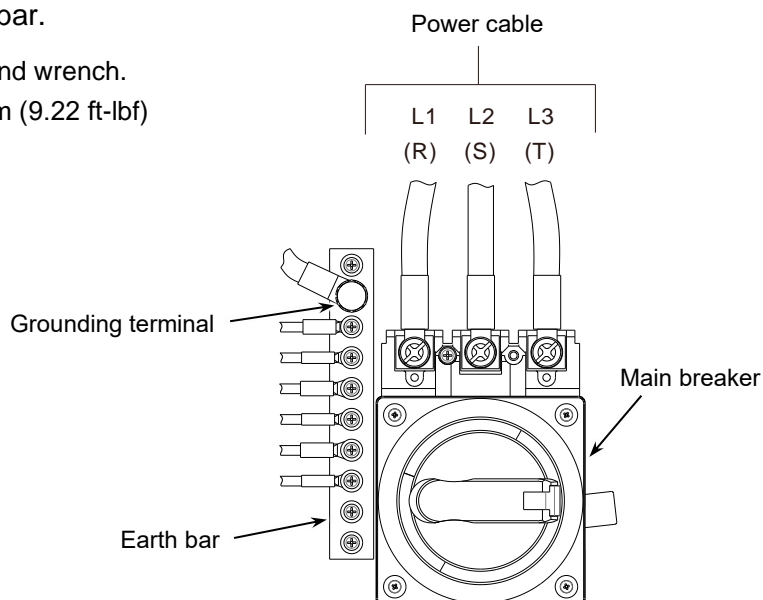

Figure 3-8 Connection of Power Cable and Grounding Terminal

[Tips]

See "Table 3-1 Power Cable and Main Breaker (This product)" on page 3-7 for torque value.

8. Attach the breaker cover to the breaker.

9. Attach the front panel.

10. Connect the power cable to the power breaker on customer side (primary side).

11. Connect the communication cables with P1 and P2.

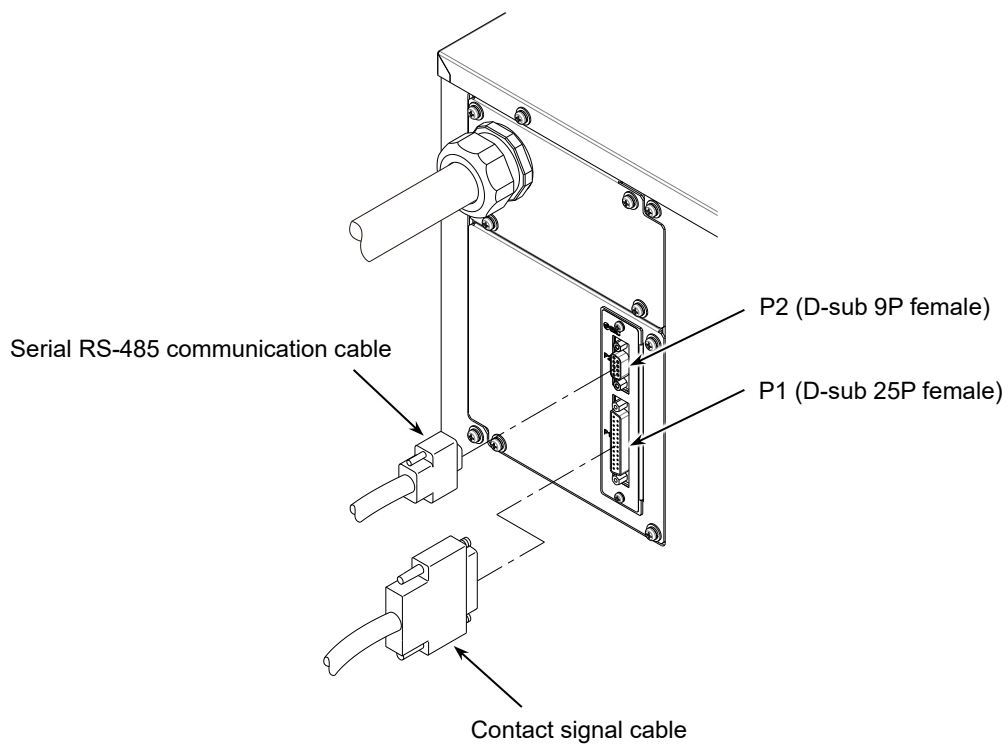

Figure 3-9 Signal line mounting

3.3.5 Installation of circulating fluid and facility water piping

⚠ CAUTION



Regarding the circulating fluid and facility water piping, carefully consider the suitability for operating pressure, temperature, circulating fluid, and facility water. If the operating performance is not sufficient, the piping may burst during operation. Also, the use of corrosive materials such as aluminum or iron for fluid contact parts, such as piping, may lead to clogging or leakage in the circulating fluid and facility water circuits, but also refrigerant leakage and other unexpected problems. Provide protection against corrosion when you use the product.

Always insulate external circulating piping. If disregarded, there is a potential insufficient cooling performance due to heat absorption from the pipe surface, and a potential insufficient heating performance caused by thermal radiation.

When using fluorinated liquid as the circulating fluid, do not use pipe tape. Liquid leakage may occur around the pipe tape. We recommend that you use the following sealant: SMC Part No., HRZ-S0003 (Silicone sealant).

Use clean pipes and pipe fittings free of particles, oil, and moisture. Apply air blow to the parts before using. The presence of particles, oil, or moisture in the circulating fluid circuit causes insufficient cooling, system failure (attributed to moisture freeze when entering the system), and/or foaming of the circulating fluid in the tank.

The total capacity of circulating fluid required by external piping should remain under the capacity of the sub tank. Potential problem of tank overflow, when pump stop, may occur if disregarded. See “Appendix 8.1.1 System specification” in Chapter 8 for the capacity of the sub tank.

Be sure to choose a circulating fluid pipe capable of letting the fluid flow at rated flow rate or better. See “Pump performance” defined in “Appendix 8.1.1 System specification” for the flow rate rating.

Have a drip pan available in case of a fluid leak.

Do not return the circulating fluid to the unit by installing a pump in the customer system.

Make sure of the locations of ports for the circulating fluid supply, return, facility water inlet, outlet, and their corresponding connections are correct.

Secure the piping connector section with a pipe wrench and provide proper tightening to the pipe.

Do not impact the piping connector section when it is fixed or tightened. It may damage the piping or cause leakage.

The flow rate of the facility water is automatically adjusted depending on using conditions. The facility water outlet temperature can be up to 60 deg C.

■ **Pipe diameter**

Table 3-3 Pipe Diameter

Pipe	Diameter	Recommended torque (Material: SS* vs SS)
Facility water inlet	Rc1/2	20 to 25N•m (14.8 to 18.4ft-lbf)
Facility water outlet	Rc1/2	20 to 25N•m (14.8 to 18.4ft-lbf)
Circulating fluid supply port	Rc3/4	28 to 30N•m (20.7 to 22.1ft-lbf)
Circulating fluid return port	Rc3/4	28 to 30N•m (20.7 to 22.1ft-lbf)
Main tank drain port	Rc3/8 (with valve)	Piping not necessary
Sub tank drain port	Rc3/8 (with valve)	Piping not necessary
Drain pan port	Rc3/8	Piping not necessary

*: SS Stainless steel

■ **Procedure for piping installation**

Secure the pipe coupling section with a pipe wrench and provide proper tightening to the pipe.

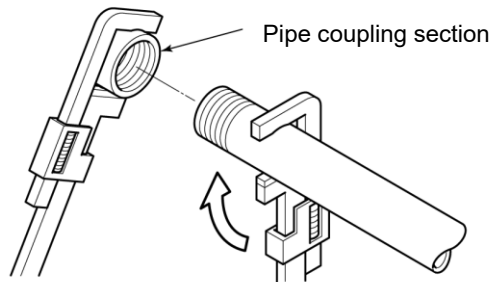

Figure 3-10 Pipe Tightening

■ Recommended piping installation

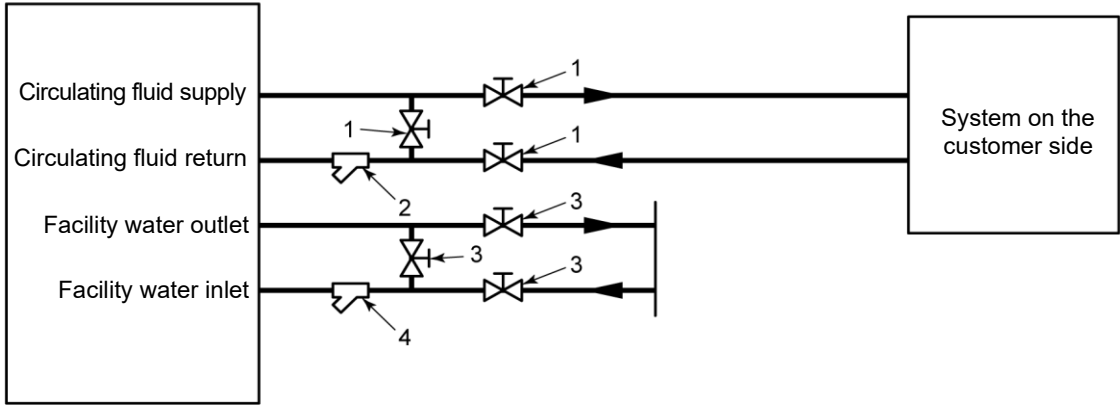

Figure 3-11 Recommended Piping Installation

Table 3-4 Recommended Pipe

No.	Name	Size	Material
1	Valve	Rc3/4	Stainless steel
2	Filter (100µm)	Rc3/4	Stainless steel
3	Valve	Rc1/2	Stainless steel
4	Filter (5µm)	Rc1/2	Stainless steel

CAUTION



No thermal insulator is assigned to facility water circuit. In order to avoid dew condensation of facility water circuit, retain the facility water temperature inside the range in Table 3-5 corresponding to installation conditions. Otherwise please insulate the facility water piping by customer.

Table 3-5 Facility water temperature range

Installation conditions		Facility water temperature range (deg C)
Ambient temperature (deg C)	Relative humidity(%)	
35	70	29 to 30
	60	27 to 30
	50	24 to 30
	40	20 to 30
	30	15 to 30
30	70	24 to 30
	60	22 to 30
	50	19 to 30
	40	15 to 30
	30	11 to 30
25	70	20 to 30
	60	17 to 30
	50	14 to 30
	40	11 to 30
	30	10 to 30
20	70	15 to 30
	60	13 to 30
	50	10 to 30
	40	
	30	
15	70	10 to 30
	60	
	50	
	40	
	30	
10	70	10 to 30
	60	
	50	
	40	
	30	

Chapter 4 System Startup and Shutdown

⚠ CAUTION



Only personnel, who have adequate knowledge of and experiences with not only this product but associated equipment, are allowed to implement system startup and shutdown.

4.1 Pre-check

Check the following items prior to starting up the product.

4.1.1 Installation condition

- Make sure that the product is installed in a horizontal position.
- No heavy object is placed on this product. This product should not be applied with an undue force, such as piping installation.
- Re-check the items defined in “3.2 Installation” on page 3-3.

4.1.2 Cable connection

Make sure proper connection of the power cable, ground, and communication cables.

4.1.3 Installation of circulating fluid and facility water piping

Make sure that circulating fluid and facility water piping are installed properly.

4.1.4 Operating signal from customer system

Make sure that no remote signal is being issued from customer system. System startup takes effect upon power-ON if this product receives a remote signal and it is in remote mode.

4.1.5 Check emergency off [EMO] switch

Make sure of the location of the EMO switch before operating the product. See section 1.7.1 “Emergency off [EMO] switch” in Chapter 1 “Safety” for details.

4.2 Opening of Facility water Valve

CAUTION



Check that the facility water complies with the water quality standard defined in section 7.1 “Water Quality Management” on page 7-1, and the requirements provided in “8.1.1 System specification” in Chapter 8 Appendix on page 8-1.

Open the facility water valve for water supply.

[Tips]

This product is outfitted with a proportional valve inside.
Facility water may not flow upon system startup which is normal.

4.3 Filling of Circulating Fluid

CAUTION



Circulating fluid usage varies with system models. See section 8.1.1 “System specification” in Chapter 8 for the designated circulating fluid for a specific model.

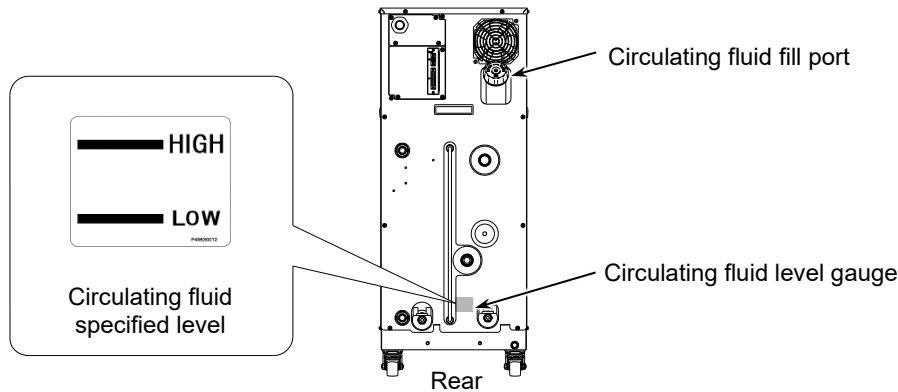

Figure 4-1 Circulating Fluid Fill Port and Circulating Fluid Level Gauge

4.3.1 Preparation of circulating fluid

- When the circulating fluid is a fluorinated fluid

CAUTION

Make sure of no oil, moisture, and other foreign materials contaminate the circulating fluid. Potential cooling error or system failure, due to contaminant freezing internally, may occur if disregarded.

- When the circulating fluid is a 60% ethylene glycol aqueous solution
Always check the concentration of the circulating fluid.

CAUTION

Low concentration EG in the circulating fluid may cause system failure due to it being frozen in the system.
High concentration EG in the circulating fluid may cause circulating pump overload, which triggers “Return Low Flow FLT”.
Potential cooling error may occur if the circulating fluid varies in concentration.

- When the circulating fluid is water

CAUTION

Attention should be taken on water quality. Ensure water quality is within specified range, and other foreign materials contaminate the circulating fluid. Potential cooling error or system failure, due to contaminant freezes internally, may occur if disregarded.

4.3.2 Filling of circulating fluid

Remove the circulating fluid fill cap and fill the circulating fluid until it reaches its specified level.

The circulating fluid specified level is the range between “HIGH” and “LOW” in Figure 4-1.

Be sure to tighten the cap until it clicks after fluid supply.

If the circulating fluid is supplied over the specified level, follow the procedure provided in section 7.3.1 “Draining of circulating fluid out of tank” on page 7-4 to drain excess fluid until it reaches the specified level.

[Tips]

The range between “HIGH” and “LOW” represents liquid level in normal running condition. As you start filling up the chiller, the internal transferring pump immediately starts pumping fluid from the Sub Tank into the Main Tank. Thus, the fluid level in the level gauge will start to drop.

During initial priming of the external piping, additional fluid is needed. See section 8.1.1 “System specification” on page 8-1 for Sub Tank and Main Tank capacity.

WARNING



Circulating fluid must be filled to be in the range between “HIGH” and “LOW”. Potential overflow of hot circulating fluid may occur due to excessive volume. Total fluid volume use to fill up the system including initial priming should not exceed combined volume of Sub Tank and Main Tank. If level is below the “LOW” mark, this product will trigger an alarm.

CAUTION



When filling the circulating fluid, make sure that the fluid inside this product has dropped to room temperature for the prevention of burns. To prevent moisture, which is formed by condensation of the air, from finding its way into the tank, ensure the circulating fluid at room temperature when filling the fluid. Be sure to tighten the cap until it clicks after fluid supply. Potential circulating fluid vaporization or moisture intrusion due to condensation of ambient air may occur if disregarded.

4.4 Requirement for System Startup

4.4.1 Turning ON power

1. Make sure that the main breaker for this product is OFF, and release lockout/tagout of the power breaker on customer side (primary side). Then, turn ON the power.

2. Turn ON the main breaker of this product.

The “Model Indication screen” and “System Information screen” are displayed in sequence on the LCD screen. The screen will change to the “Status screen 1” in approximately . 20 seconds, and the product is ready to run.

[Tips]

It is normal if the “System Information screen” is not displayed. See section 5.3.35 “System Information screen ” in “Chapter 5 System Operation” on page 5-36 for details.

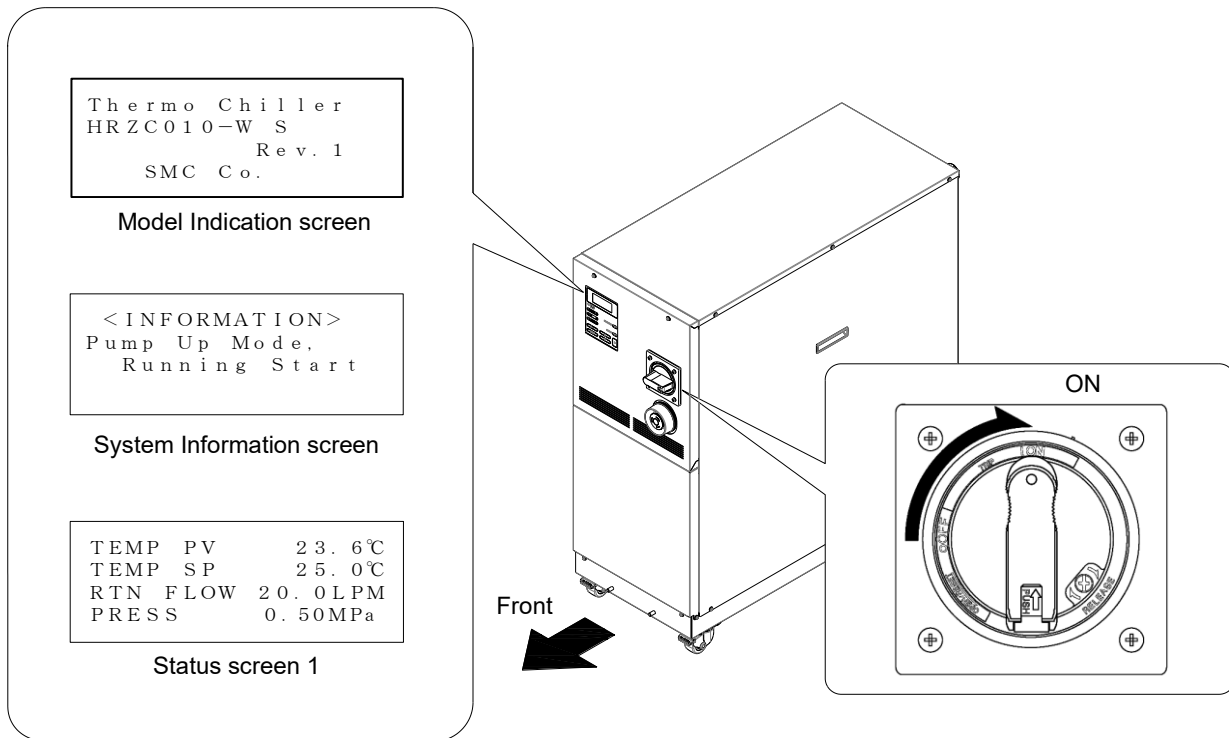

Figure 4-2 Main Breaker at 'ON'

⚠ WARNING



Press the emergency off [EMO] switch immediately upon occurrence of abnormal conditions. Be sure to turn OFF the main breaker afterwards.

4.4.2 Circulating fluid temperature setting

From the “Setting screen” on the LCD screen, set the circulating fluid at any temperature. See section 5.4 “Examples of System Operation” in “Chapter 5 System Operation” on page 5-37 for operating procedure.

[Tips]

See section 8.1.1 “System specification” in “Chapter 8 Appendix” on page 8-1 for the setting range of circulating fluid temperature.

4.5 System Startup and Shutdown

4.5.1 System startup

Press the [START/STOP] key on the operation display panel.

The [RUN] lamp on the operation display panel comes on, and the “System Information screen” is flashing. The screen then changes to the “Status screen 1”, which initiates system operation.

[Tips]

It is normal if the “System Information screen” is not displayed. See section 5.3.35 “System Information screen” in “Chapter 5 System Operation” on page 5-36 for details.

4.5.2 System shutdown

Press the [START/STOP] key on the operation display panel.

If the “System Information screen” is flashing on the LCD screen, and the [RUN] lamp comes on, the compressor comes to a halt approximately, 20 seconds after circulating pump stops for protection of the compressor. The screen is returned to the “Setting screen 1”, which prompts the [RUN] lamp to go out.

[Tips]

See section 5.3.35 “System Information screen” in “Chapter 5 System Operation” on page 5-36 for details on the System information screen.

CAUTION



Internal equipment may remain at elevated or lowered temperatures immediately after the product shutdown. Potential burns or frostbite may happen if your skin comes in contact with these surfaces. Further work is allowed only when the product reaches room temperature.

CAUTION



Emergency off [EMO] switch and main breaker (OFF) should not be used for system shutdown unless it is an emergency.

Chapter 5 System Operation

5.1 Operation Display Panel

Use the operation display panel located in front of the system for the basic operations.

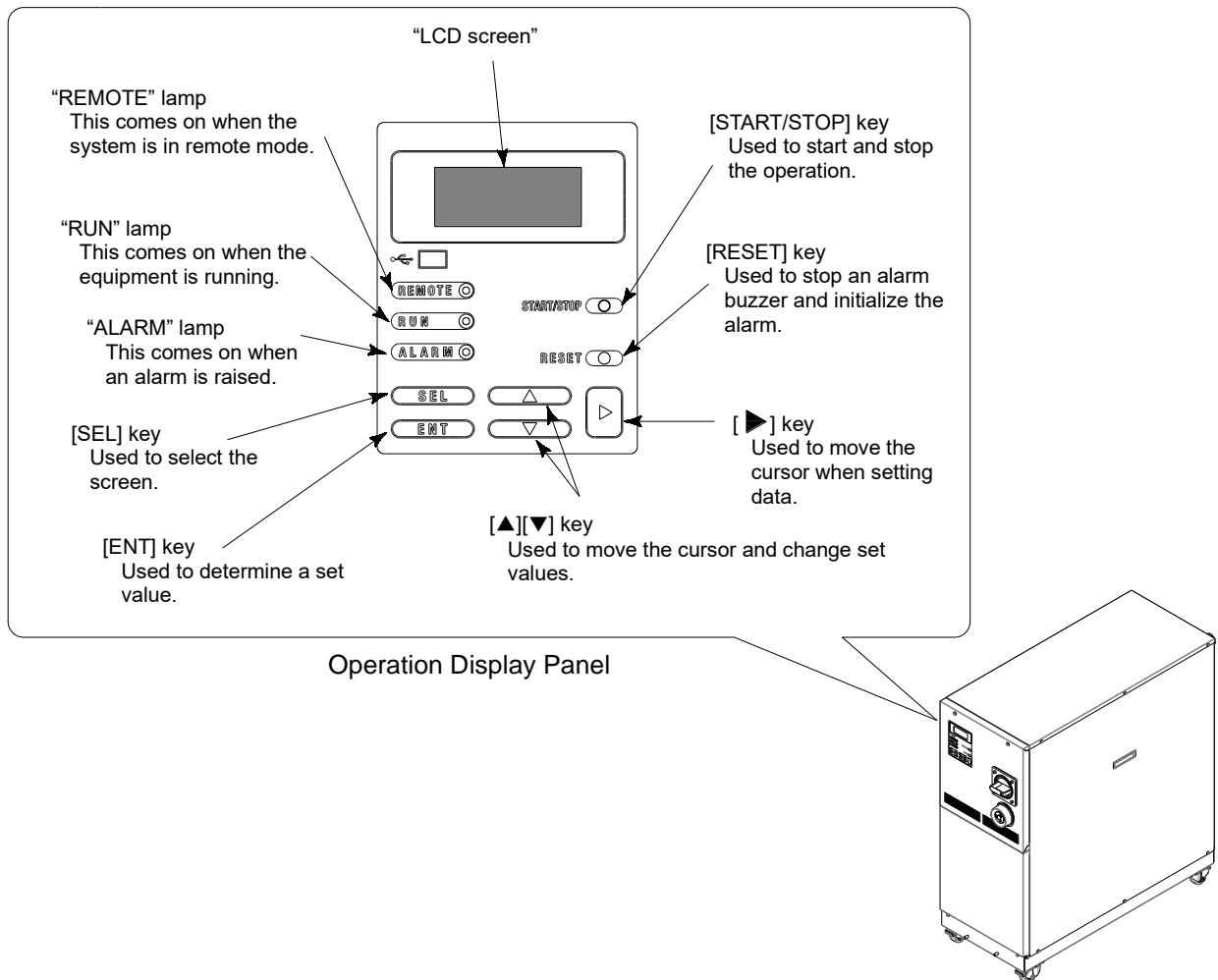

Figure 5-1 Operation Display Panel

CAUTION

Be sure to use your fingers only to operate the Operation Display Panel. Using sharp object will damage the panel.

5.2 Flow Chart of Operation Screen

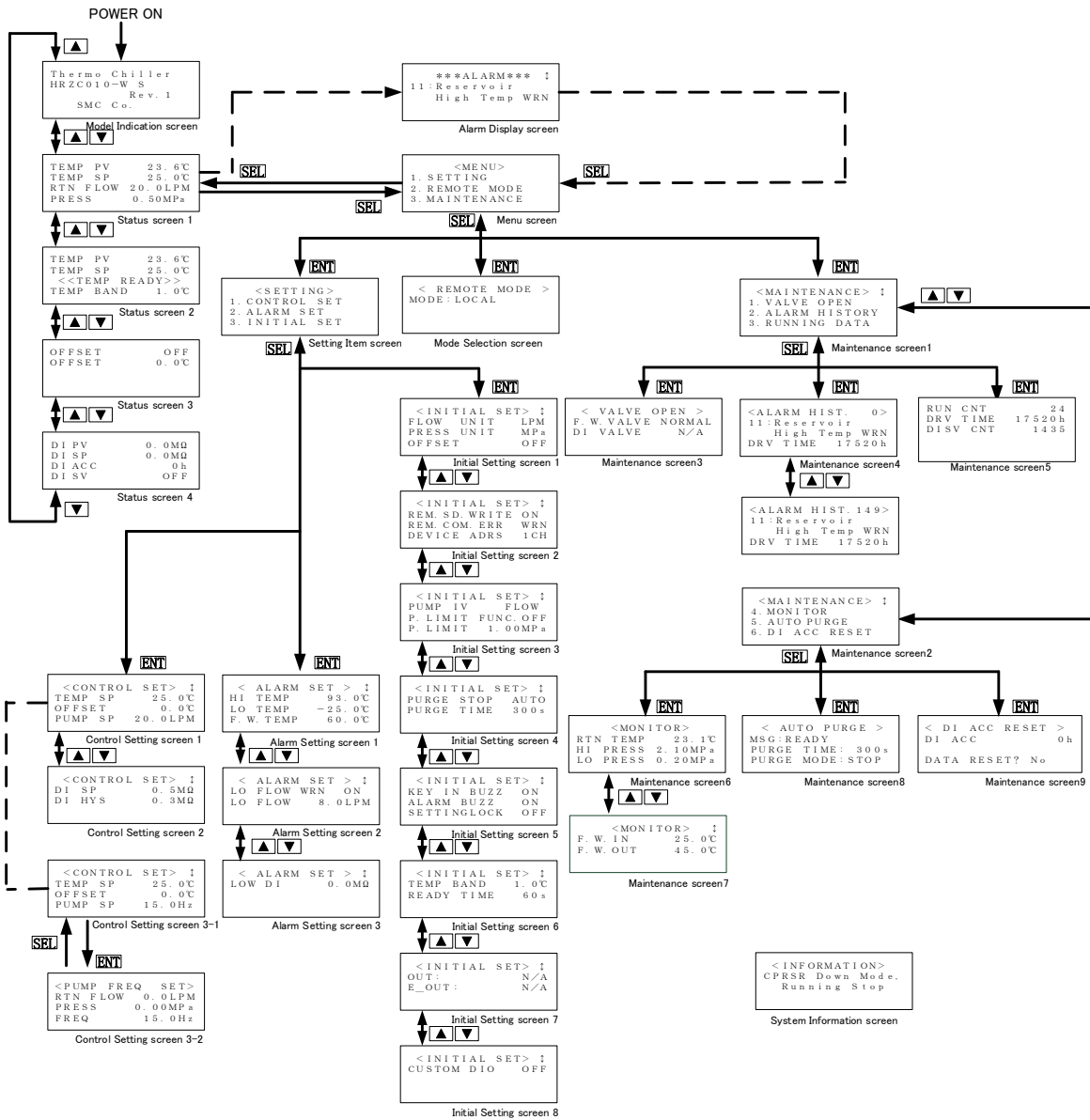

Figure 5-2 Flow Chart of Operation Screen

[Tips]

1. After the menu screen, pressing the [SEL] key can make the screen return to the previous page.
2. For the items which are set numerically can be set by minimum unit of displayed value.
3. The contents displayed on the screen may change depending on the options or settings. Please refer to the description page of each screen.

Table 5-1 Descriptions of Operation Screens

Screen	Descriptions	Reference
Model Indication screen	Displays the model and revision No. of this product.	Page 5-4
Status screen 1 to 4	Displays the operating condition of this product.	Page 5-5 to 5-8
Alarm Display screen	The alarm number and alarm message are displayed in the event of an error in this product. Not displayed if no error.	Page 5-9
Menu screen	Allows setting screen selection.	Page 5-9
Setting screen	Allows switching to "Control Setting screen", "Alarm Setting screen" and "Initial Setting screen".	Page 5-10
Control screen 1, 2, 3-1, 3-2	Allows the setting of pump frequency, pressure or flow rate by pump inverter.	Page 5-11 to 5-14
Alarm Setting screen 1 to 3	Allows the setting of set values for the alarm of temperature and flow rate.	Page 5-15 to 5-17
Initial Setting screen 1 to 8	Allows the setting of set values.	Page 5-18 to 5-25
Mode Selection screen	Allows communication mode selection.	Page 5-26
Maintenance screen 1 to 9	Not used during system operation. Not allowed to use unless otherwise specified.	Page 5-27 to 5-35
System Information screen	Displays the status of system startup and shutdown.	Page 5-36

5.3 Operation Screen

5.3.1 Model Indication screen

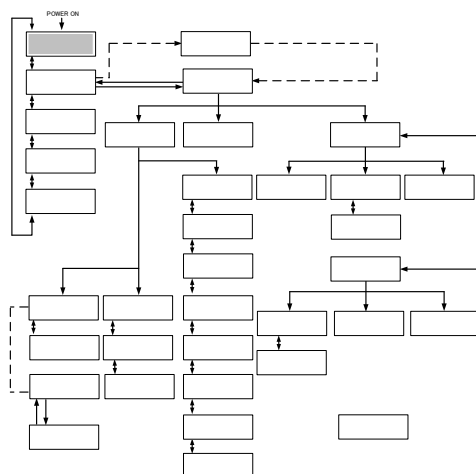
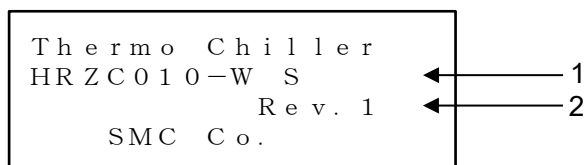

Figure 5-3 Model Indication Screen

The “Model Indication screen” is displayed upon power-ON of this product. This screen remains ON for approximately . 5 seconds and is automatically switched to the “Status screen 1”. The “Alarm Display screen” is displayed if error occurs in this product.

Table 5-2 Model Indication screen

No.	Item	Descriptions
1	-	System model
2	-	System revision No.

5.3.2 Status screen 1

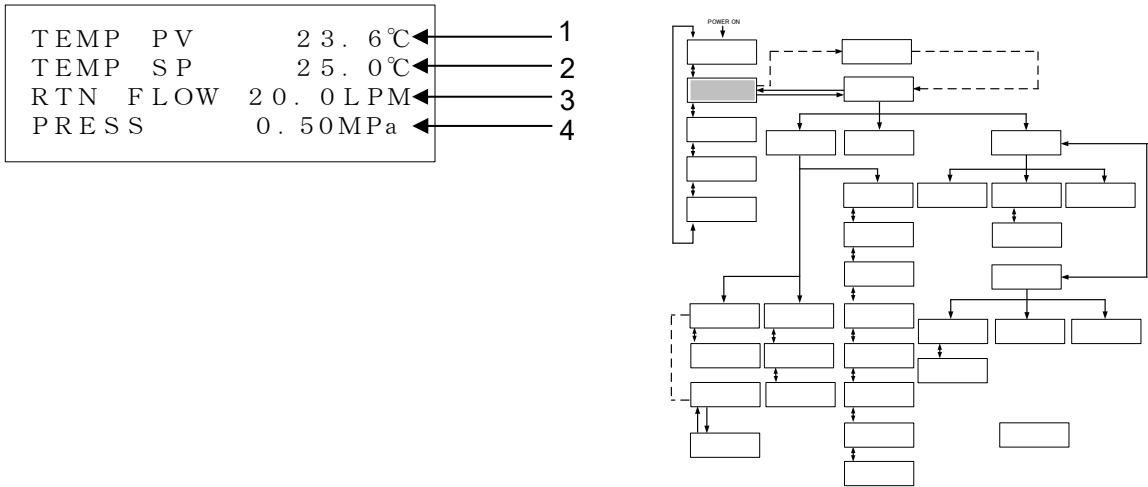

Figure 5-4 Status screen 1

Table 5-3 Status screen 1

No.	Item	Descriptions
1	TEMP PV	Supply temperature of the circulating fluid (A value derived according to the offset*1 if applied)
2	TEMP SP	Set value of circulating fluid supply temperature
3	RTN FLOW	Return flow rate of the circulating fluid
4	PRESS	Supply pressure of the circulating fluid

[Tips]

See “Appendix 8.4 Offset Function” in Chapter 8 on page 8-16 for details on offset (*1).

Unit of RTN FLOW and PRESS can be selected on “Initial Setting screen 1”.
See “5.3.16 Initial Setting screen 1” (page 5-18) for details.

5.3.3 Status screen 2

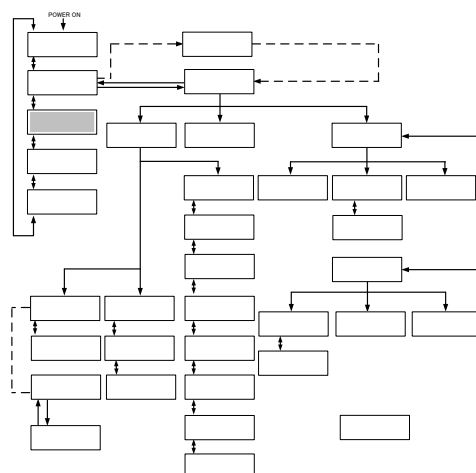
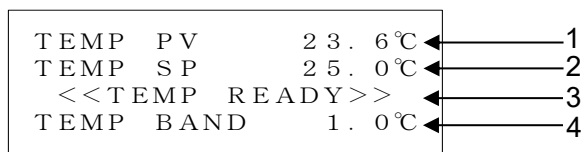

Figure 5-5 Status screen 2

Table 5-4 Status screen 2

No.	Item	Descriptions
1	TEMP PV	Supply temperature of the circulating fluid
2	TEMP SP	Set circulating fluid temperature
3	<<TEMP READY>>	Displays the BAND/READY [Displayed when set value conditions are satisfied*1]
4	TEMP BAND	Set value of BAND range*1

[Tips]

See “Appendix 8.5 BAND/READ” in Chapter 8 on page 8-19 on offset features (*1).

5.3.4 Status screen 3

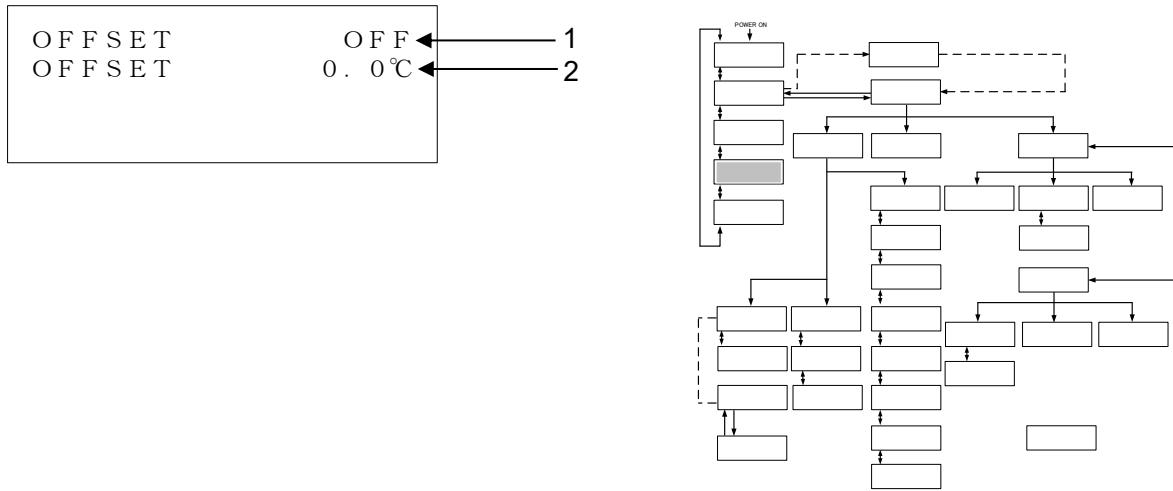

Figure 5-6 Status screen 3

Table 5-5 Status screen 3

No.	Item	Descriptions
1	OFFSET	The current offset mode*1
2	OFFSET	Set offset*1

[Tips]

See "Appendix 8.4 Offset Function" in Chapter 8 on page 8-16 on offset features (*1).

5.3.5 Status screen 4

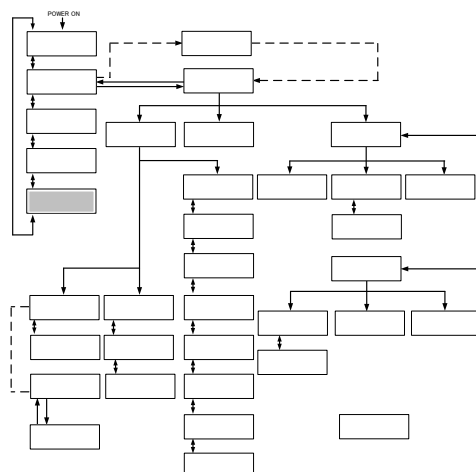
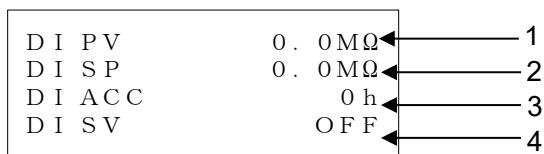

Figure 5-7 Status screen 4

Table 5-6 Status screen 4

No.	Item	Descriptions
1	DI PV	Circulating fluid electric resistivity.
2	DI SP	Set value of circulating fluid electric resistivity.
3	DI ACC	Accumulated time that the solenoid valve in DI circuit is activated.
4	DI SV	Open/close status of solenoid valve in DI circuit.

[Tips]

It is displayed only if the DI Control Kit (optional) is provided.

5.3.6 Alarm Display screen

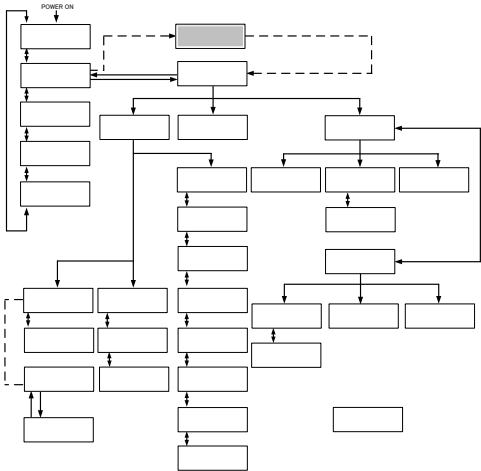

Figure 5-8 Alarm Display screen

In the event of an error in this product, the current screen is switched to the “Alarm Display screen” to display the relevant alarm code, and message. The “Alarm Display screen” is displayed only if an error is raised. See section 6.2 “Troubleshooting” in “Chapter 6 Error Message and Troubleshooting” on page 6-2 for alarm numbers and messages.

5.3.7 Menu screen

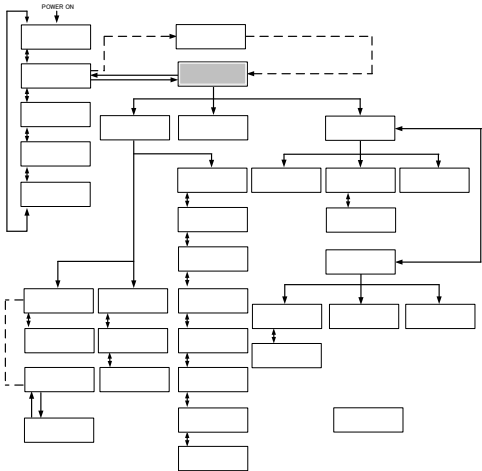

Figure 5-9 Menu screen

Table 5-7 Menu screen

No.	Item	Descriptions
1	SETTING	Switches to the “Setting screen” with the press of the [ENT] key.
2	REMOTE MODE	Switches to the “Mode Selection screen” with the press of the [ENT] key.
3	MAINTENANCE	Switches to the “Initial Setting screen 1” with the press of the [ENT] key.

[Tips]

[▲] or [▼] key is used for selecting “Item.”

5.3.8 Setting screen

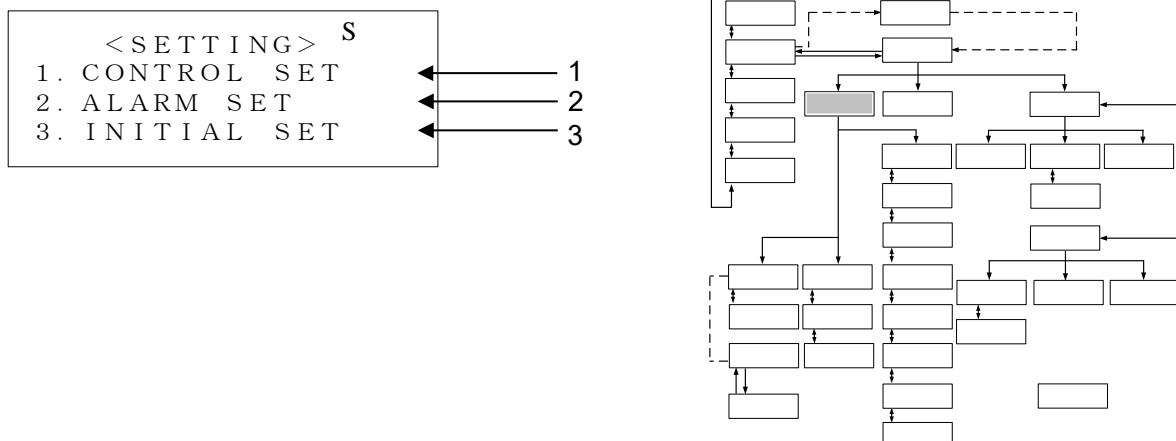

Figure 5-10 Setting screen

Table 5-8 Setting screen

No.	Item	Descriptions
1	CONTROL SET	Switches to the “Control Setting screen 1” with the press of the [ENT] key.
2	ALARM SET	Switches to the “Alarm Setting screen 1” with the press of the [ENT] key.
3	INITIAL SET	Switches to the “Initial Setting screen 1” with the press of the [ENT] key.

[Tips]

[▲] or [▼] key is used for selecting “Item”.

5.3.9 Control Setting screen 1

This screen is displayed if the PUMP IV is set to PRESS or FLOW on the Initial Setting screen 3. If PUMP IV is set to FREQ, this screen is not displayed and 5.3.11 Control Setting screen 3-1 (page 5-13) is displayed.

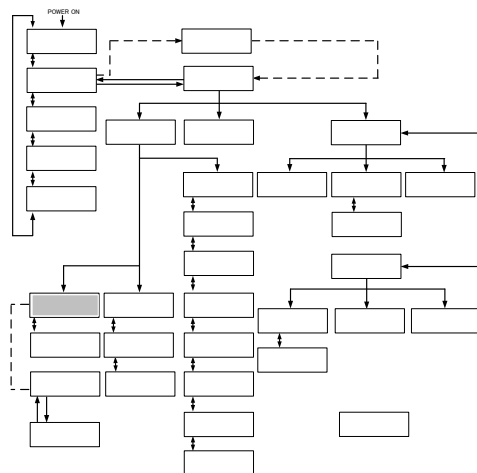
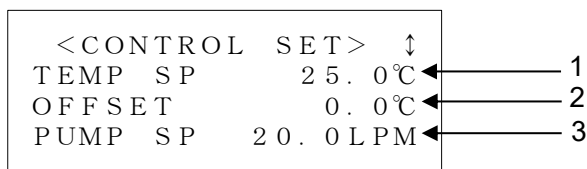

Figure 5-11 Control Setting screen 1

Table 5-9 Control Setting screen 1

No.	Item	Descriptions	Setting Range	Factory Default
1	TEMP SP	Allows the setting of circulating fluid supply temperature.	HRZC002-WS/W1S : -10.0~90.0deg C HRZC004/008/010-WS/W1S : -20.0~90.0deg C HRZC***-W2S : 10.0~60.0deg C	25.0 deg C
2	OFFSET	Allows the setting of OFFSET value*1	-20.0 to 20.0 deg C	0.0 deg C
3	PUMP SP	Allows the setting of circulating fluid flow rate. (When PUMP IV on "Initial Setting screen 3" is set to FLOW.)	10.0 to 40.0LPM	20.0LPM
		Allows the setting of circulating fluid supply pressure. (When PUMP IV on "Initial Setting screen 3" is set to PRESS.)	0.10 to 1.00MPa	0.10MPa

[Tips]

In the case of using Offset Function, select any one of MODE 1 to 3 on No.3 of "Initial Setting screen 1". See "Chapter 8 8.4 Offset Function" (page 8-16) for details>(*1).

[▲] or [▼] key is used for selecting "Item" and pressing [ENT] key enables changing the set point.

Unit of PUMP SP can be selected on "Initial Setting screen 1". See "5.3.16 Initial Setting screen 1" (page 5-18) for details.

5.3.10 Control Setting screen 2

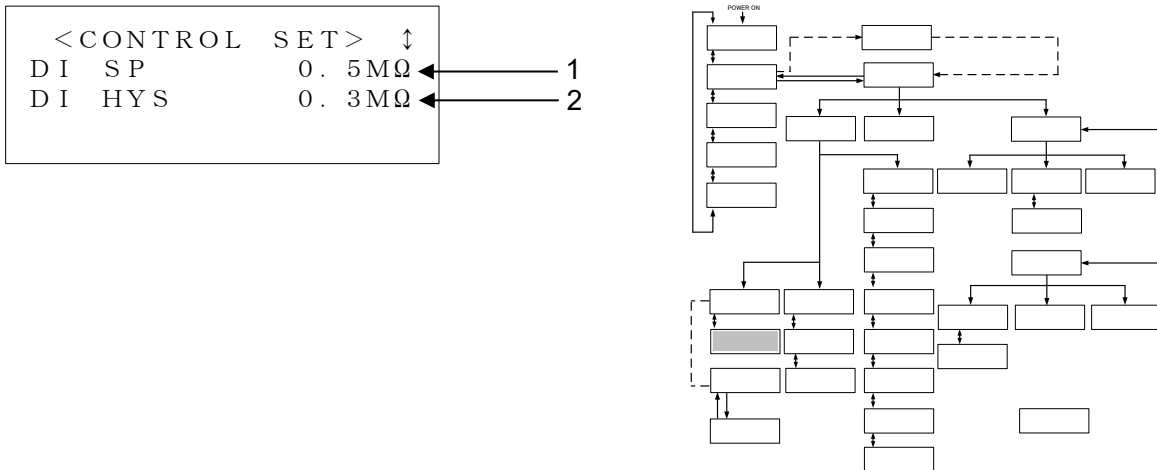

Figure 5-12 Control Setting screen 2

Table 5-10 Control Setting screen 2

No.	Item	Descriptions	Setting Range	Factory Default
1	DI SP	Allows the setting of circulating fluid electric resistivity.	0.0 to 2.0MΩ	0.5MΩ
2	DI HYS	Allows the setting of hysteresis for circulating fluid electric resistivity (See Figure about hysteresis.).	0.0 to 0.9MΩ	0.3MΩ

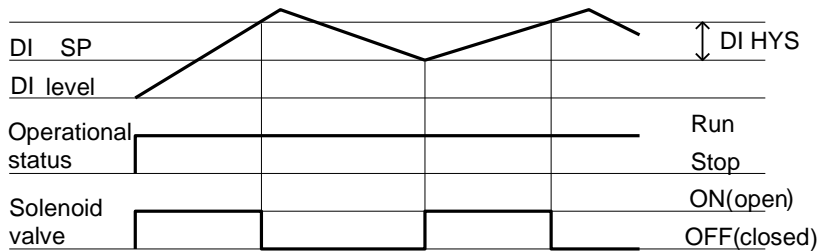

Figure 5-13 DI Hysteresis setting (DI HYS)

[Tips]

It is displayed only if the DI Control Kit (optional) is provided.

[▲] or [▼] key is used for selecting “Item” and moving to the other Control Setting screens. Pressing the [ENT] key enables changing the set point.

5.3.11 Control Setting screen 3-1

This screen is displayed if the PUMP IV is set to FREQ on the Initial Setting screen 3.

If PUMP IV is set to PRESS or FLOW, this screen will not be displayed and 5.3.9 Control Setting screen 1 (page 5-11) will be displayed.

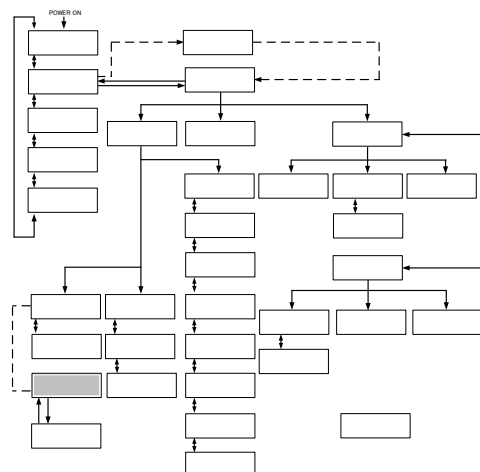
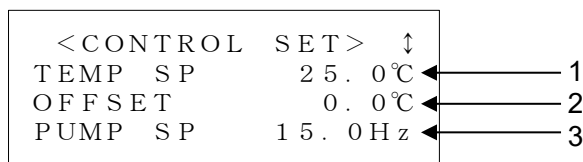

Figure 5-14 Control Setting screen3-1

Table 5-11 Control Setting screen3-1

No.	Item	Descriptions	Setting Range	Factory Default
1	TEMP SP	Allows the setting of circulating fluid supply temperature.	HRZC002-WS/W1S : -10.0~90.0deg C HRZC004/008/010-WS/W1S : -20.0~90.0deg C HRZC***-W2S : 10.0~60.0deg C	25.0 deg C
2	OFFSET	Allows the setting of OFFSET value* 1	-20.0 to 20.0 deg C	0.0 deg C
3	PUMP SP	Switched to the "Control Setting screen 3-2"(Pump frequency setting screen).	-	-

[Tips]

In the case of using Offset Function, select any one of MODE 1 to 3 on No.3 of "Initial Setting screen 1". See "Chapter 8 8.4 Offset Function" (page 8-16) for details (*1).

[▲] or [▼] key is used for selecting "Item" and pressing [ENT] key enables the change of set point for TEMP SP and OFFSET.

5.3.12 Control Setting screen 3-2

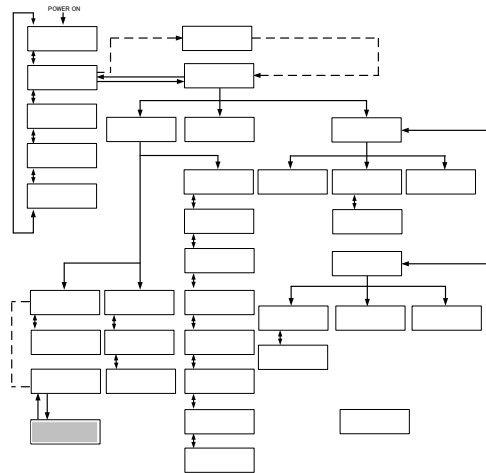
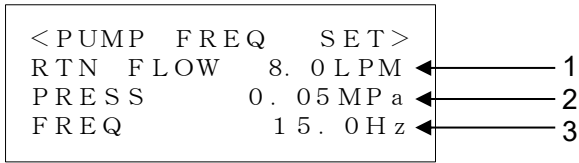

Figure 5-15 Control Setting screen 3-2

Table 5-12 Control Setting screen 3-2

No.	Item	Descriptions	Setting Range	Factory Default
1	RTN FLOW	Return flow rate of circulating fluid.	-	-
2	PRESS	Supply pressure of circulating fluid.	-	-
3	FREQ	Allows the setting of pump frequency ("Control Setting screen 3-2" is displayed only if PUMP IV on "Initial Setting screen 3" is set to FREQ).	15.0 to 60.0Hz	15.0Hz

[Tips]

Pressing [ENT] key enables to change the set point of FREQ.

Unit of RTN FLOW and PRESS can be selected on "Initial Setting screen 1". See "5.3.16 Initial Setting screen 1" (page 5-18) for details.

5.3.13 Alarm Setting screen 1

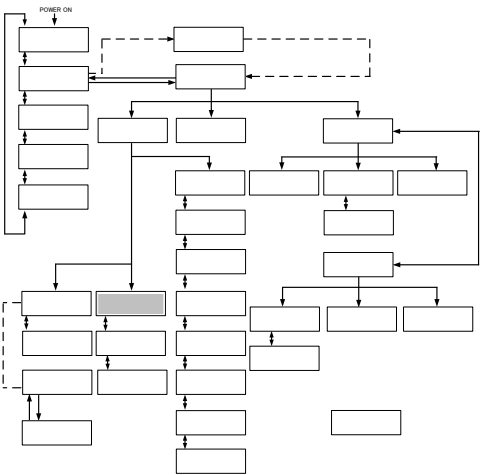
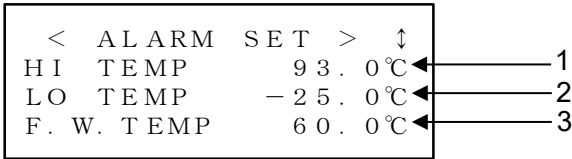

Figure 5-16 Alarm Setting screen 1

Table 5-13 Alarm Setting screen 1

No.	Item	Descriptions	Setting Range	Factory Default
1	HI TEMP	Allows the setting of temperature to generate “11:Reservoir High Temp. WRN”. Alarm is raised when circulating fluid temperature exceeds the set value.	HRZC002-WS/W1S : -10.0~93.0deg C HRZC004/008/010-WS/W1S : -20.0~93.0deg C HRZC***-W2S : 10.0~63.0deg C	HRZC***-WS/W1S : 93.0deg C HRZC***-W2S : 63.0deg C
2	LO TEMP	Allows the setting of temperature to generate “32:Reservoir Low Temp. WRN”. Alarm is raised when circulating fluid temperature falls below the set value.	HRZC002-WS/W1S : -15.0~90.0deg C HRZC004/008/010-WS/W1S : -25.0~90.0deg C HRZC***-W2S : 5.0~60.0deg C	HRZC002-WS/W1S : -15.0deg C HRZC004/008/010-WS/W1S : -25.0deg C HRZC***-W2S : 5.0deg C
3	F.W. TEMP	Allows the setting of temperature to generate “30:F. Water High Temp. WRN”. Alarm is raised when facility water temperature exceeds the set value.	45.0 to 60.0 deg C	55.0 deg C

[Tips]

[▲] or [▼] key is used for selecting “Item” and moving to other Alarm Setting screens. Pressing the [ENT] key enables to change the set value.

5.3.14 Alarm Setting screen 2

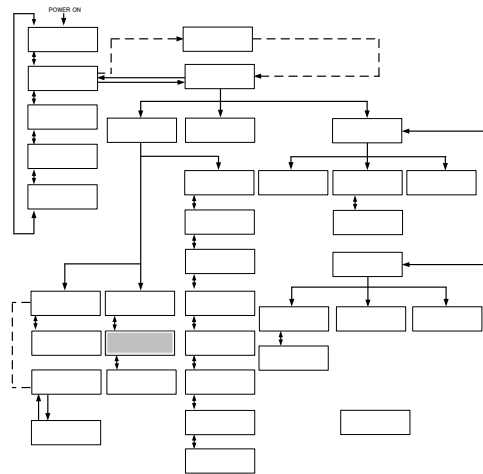
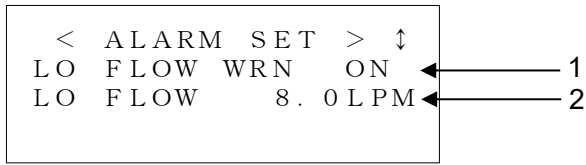

Figure 5-17 Alarm Setting screen2

Table 5-14 Alarm Setting screen 2

No.	Item	Descriptions	Setting Range	Factory Default
1	LO FLOW WRN	Allows the setting of "13:Return Low Flow WRN" (valid: ON/invalid: OFF). Alarm is not raised if invalid: OFF is selected.	OFF, ON	ON
2	LO FLOW	Allows the setting of flow rate to generate "13: Return Low Flow WRN". Alarm is raised when circulating fluid flow rate falls below the set value.	8.0 to 40.0LPM	8.0LPM

[Tips]

[▲] or [▼] key is used for selecting "Item" and moving to other Alarm Setting screens. Pressing the [ENT] key enables to change the set value.

5.3.15 Alarm Setting screen 3

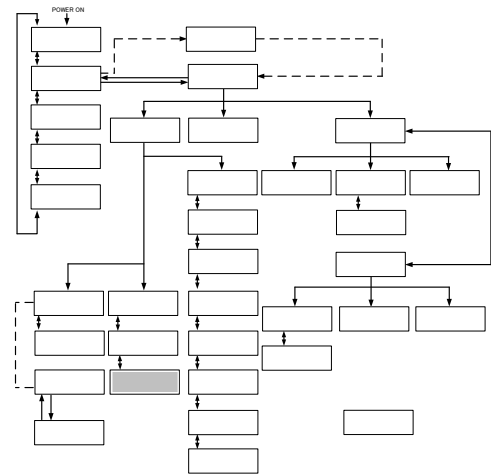
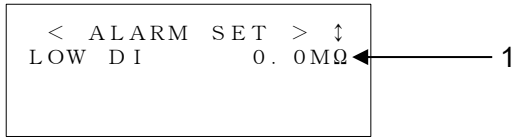

Figure 5-18 Alarm Setting screen 3

Table 5-15 Alarm Setting screen 3

No.	Item	Descriptions	Setting Range	Factory Default
1	LOW DI	Allows the setting of DI value to generate "24: DI Low Level WRN". Alarm is raised when DI value falls below the set value. Alarm is cancelled if the set value is 0.	0.0 to 2.0MΩ	0.0MΩ

[Tips]

It is displayed only if the DI Control Kit (optional) is provided.

[▲] or [▼] key is used for selecting "Item" and moving to other Alarm Setting screens. Pressing the [ENT] key enables to change the set value.

5.3.16 Initial Setting screen 1

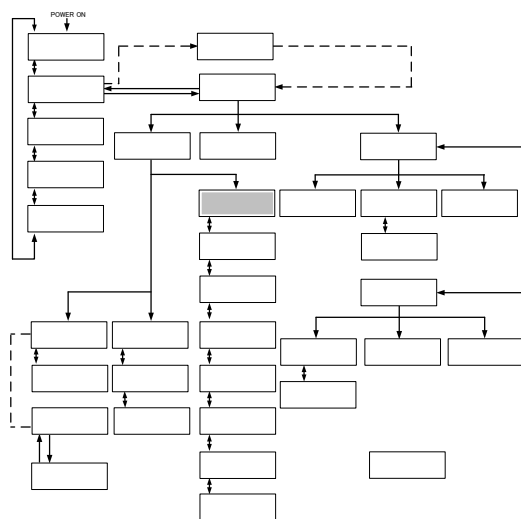
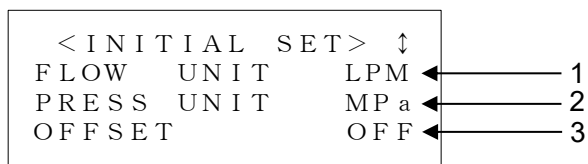

Figure 5-19 Initial Setting screen 1

Table 5-16 Initial Setting screen 1

No.	Item	Descriptions	Setting Range	Factory Default
1	FLOW UNIT	Displays flow rate unit. It cannot be changed.	-	LPM
2	PRESS UNIT	Displays pressure unit. It cannot be changed.	-	MPa
3	OFFSET	Allows the selection of Offset MODE.	MODE1 to 3, OFF	OFF

[Tips]

[▲] or [▼] key is used for selecting “Item” and moving to other Initial Setting screens. Pressing the [ENT] key enables to select the setting.

5.3.17 Initial Setting screen 2

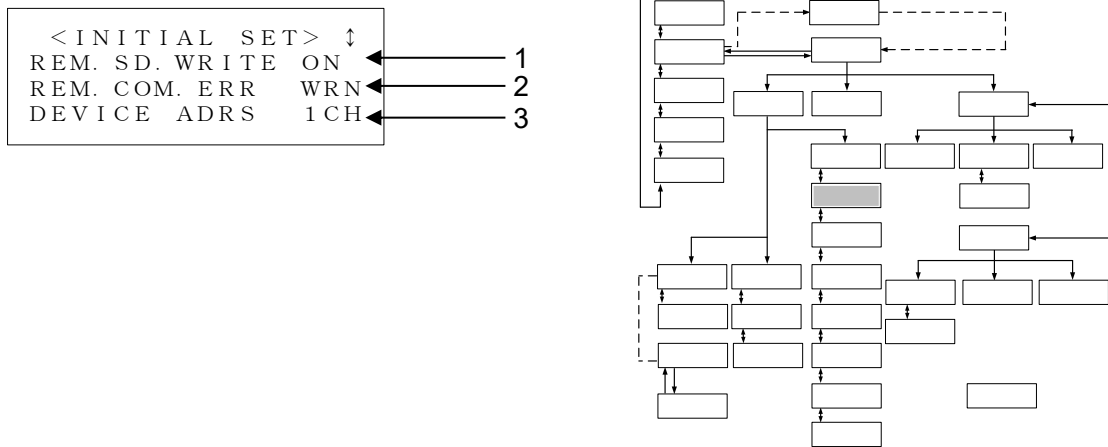

Figure 5-20 Initial Setting screen 2

Table 5-17 Initial Setting screen 2

No.	Item	Descriptions	Setting Range	Factory Default
1	REM.SD.WRITE	Store the TEMP SP and FLOW SP value with serial communication. TEMP SP and FLOW SP will be set to stored value after turning ON the main breaker again.	OFF, ON	ON
2	REM.COM.ERR	Allows the selection of system condition when serial communication error occurs (WRN: Stop, FLT: Continued).	WRN, FLT	WRN
3	DEVICE ADRS	Allows the setting of the device address for serial communication.	1 to 32CH	1

[Tips]

[▲] or [▼] key is used for selecting “Item” and moving to other Initial Setting screens. Pressing the [ENT] key enables to select the setting.

5.3.18 Initial Setting screen 3

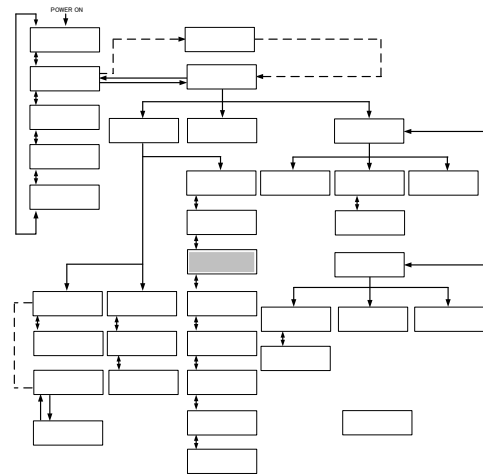
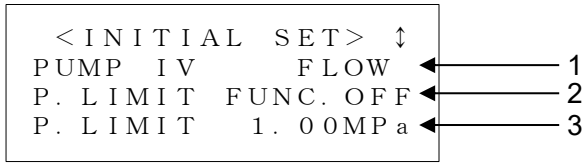

Figure 5-21 Initial Setting screen 3

Table 5-18 Initial Setting screen 3

No.	Item	Descriptions	Setting Range	Factory Default
1	PUMP IV	Allows the selection of the controlled object for pump operation. FREQ: Pump frequency control. FLOW: Circulating fluid Flow rate control. PRESS: Pump supply pressure control.	FREQ FLOW PRESS	FLOW
2	P.LIMIT FUNC.	Allows the setting of pump supply pressure upper limit function (Valid: ON, Invalid: OFF).	OFF, ON	OFF
3	P.LIMIT	Allows the setting of pump supply pressure upper limit value. This function enables the pump supply pressure not to exceed the upper limit value to protect customer system.	0.10 to 1.00MPa	1.00MPa

[Tips]

[▲] or [▼] key is used for selecting “Item” and moving to other Initial Setting screens. Pressing the [ENT] key enables to select the setting or set value.

5.3.19 Initial Setting screen 4

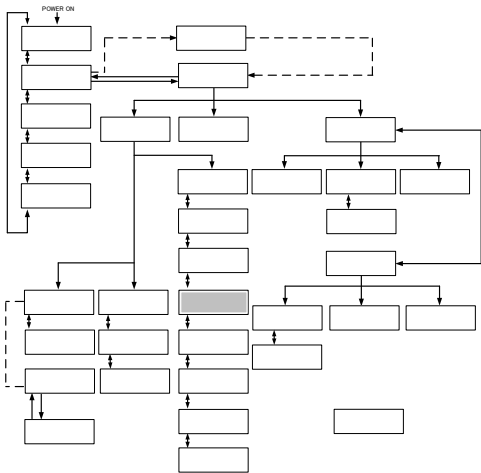
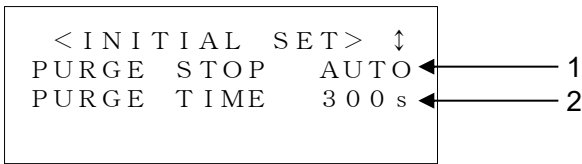

Figure 5-22 Initial Setting screen 4

Table 5-19 Initial Setting screen 4

No.	Item	Descriptions	Setting Range	Factory Default
1	PURGE STOP	Allows the selection of automatic recovery stop mode. AUTO: Recovery operation stops automatically when clection finished normally. TIME: Recovery continues for the setting time.	AUTO, TIME	AUTO
2	PURGE TIME	When "AUTO" mode, allows the setting for the time to raise "TIME OUT". When "TIME" mode, allows the setting of the time to continue recovery operation.	1 to 600sec	300s

[Tips]

It is displayed only if the Circulating Fluid Automatic Collector (optional) is provided.

[▲] or [▼] key is used for selecting "Item" and moving to other Initial Setting screens. Pressing the [ENT] key enables to select the setting.

5.3.20 Initial Setting screen 5

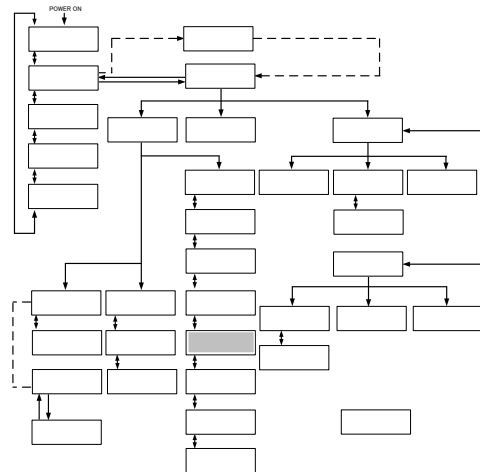

Figure 5-23 Initial Setting screen 5

Table 5-20 Initial Setting screen 5

No.	Item	Descriptions	Setting Range	Factory Default
1	KEY IN BUZZ	Allows the setting of buzzer during key input (Valid : ON, Invalid: OFF).	OFF, ON	ON
2	ALARM BUZZ	Allows the setting of alarm buzzer (Valid: ON, Invalid: OFF).	OFF, ON	ON
3	SETTINGLOCK	<p>Allow the selection of "SETTINGLOCK" function.</p> <p>This function enabled will restrict the input from operation display panel to prevent from unintended change of setting value from operation touch panel.</p> <ul style="list-style-type: none"> ·ALL: <ul style="list-style-type: none"> ·When communication mode is "LOCAL", only following operations are possible. ·START/STOP. ·Setting of "SETTINGLOCK" function. ·When communication mode is "DIO/SEREMOTE", only following operations are possible. ·Setting of "SETTINGLOCK" function. <ul style="list-style-type: none"> ·REM: <ul style="list-style-type: none"> ·When communication mode is "LOCAL", normal operation is possible. ·When communication mode is "DIO/SER REMOTE", only following operations are possible. ·Setting of communication mode. ·Setting of "SETTINGLOCK" function. <p>·OFF: "SETTINGLOCK" function is invalid.</p>	OFF REM ALL	OFF

[Tips]

[▲] or [▼] key is used for selecting "Item" and moves to other Initial Setting screens. Pressing the [ENT] key enables to select the setting.

5.3.21 Initial Setting screen 6

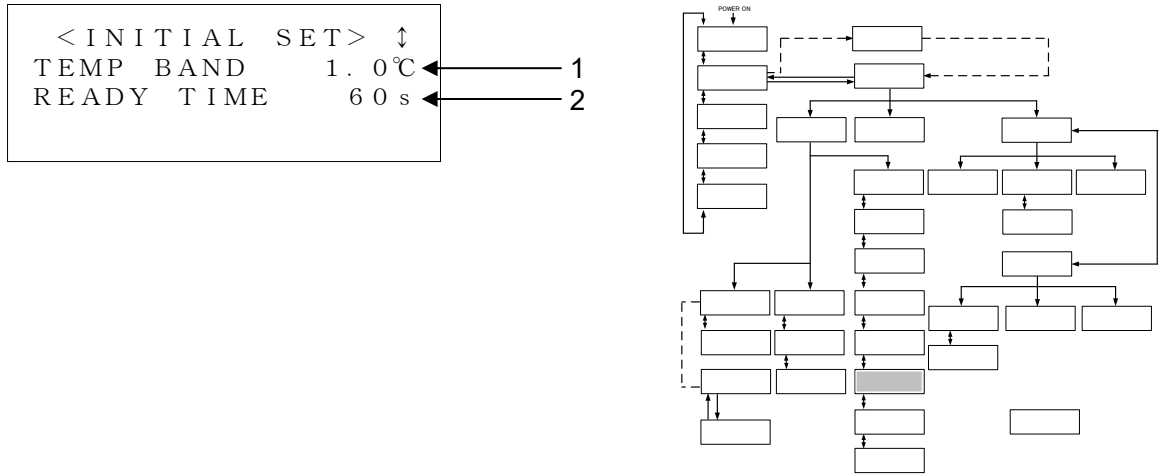

Figure 5-24 Initial Setting screen 6

Table 5-21 Initial Setting screen 6

No.	Item	Descriptions	Setting Range	Factory Default
1	TEMP BAND	Allows the setting of band range to TEMP PV.	1.0 to 99.9 deg C	1.0 deg C
2	READY TIME	Allows the setting of time from when TEMP PV reaches the BAND range to when "TEMP READY" is displayed on operation display panel and Ready signal is output.	1 to 999s	60s

[Tips]

[▲] or [▼] key is used for selecting "Item" and moves to other Initial Setting screens. Pressing the [ENT] key enables to select the set value.

5.3.22 Initial Setting screen 7

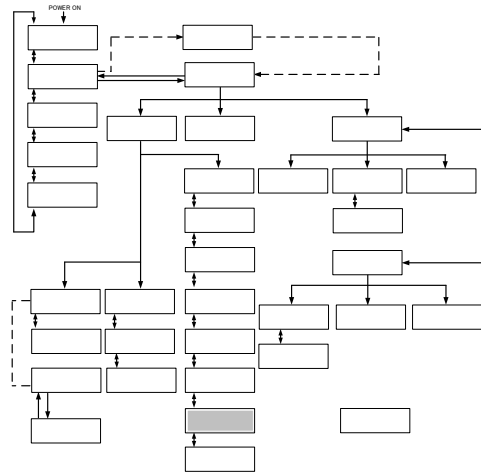

Figure 5-25 Initial Setting screen 7

Table 5-22 Initial Setting screen 7

No.	Item	Descriptions	Setting Range	Factory Default
1	OUT	Allows the selection of alarm signals for contact signal (See "Chapter 8 8.1.6 Alarm signal selection" (page 8-13) for details).	N/A ALARM01 to 32	N/A
2	E_OUT	Allows the selection either TEMP READY or AUTO PURGE signal (Output for pin No. 8 of "Chapter 8 8.1.5 Communication specification Table 8-4 Contact Signal" (page 8-10)). See communication specification for details.	N/A TEMP READY*1 AUTO PURGE	N/A

[Tips]

See "Chapter 8 8.5 BAND/READY function" (page 8-19) for TEMP BAND, READY TIME (*1).

[▲] or [▼] key is used for selecting "Item" and moves to other Initial Setting screens. Pressing the [ENT] key enables to select the setting or set value.

5.3.23 Initial Setting screen 8

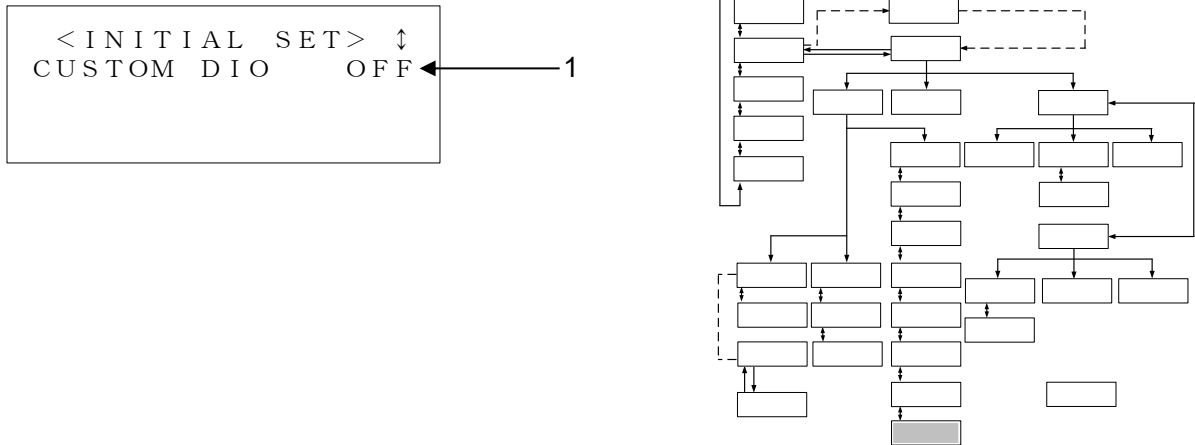

Figure 5-26 Initial Setting screen 8

Table 5-23 Initial Setting screen 8

No.	Item	Descriptions	Setting Range	Factory Default
1	CUSTOM DIO	Allows the setting for DIO signal customize (valid: ON/invalid:OFF). See "Communication Specifications" for details.	OFF, ON	OFF

[Tips]

Press the [ENT] key to make the setting changeable. Select the operation mode with the [▲] or [▼] key.

5.3.24 Mode Selection screen

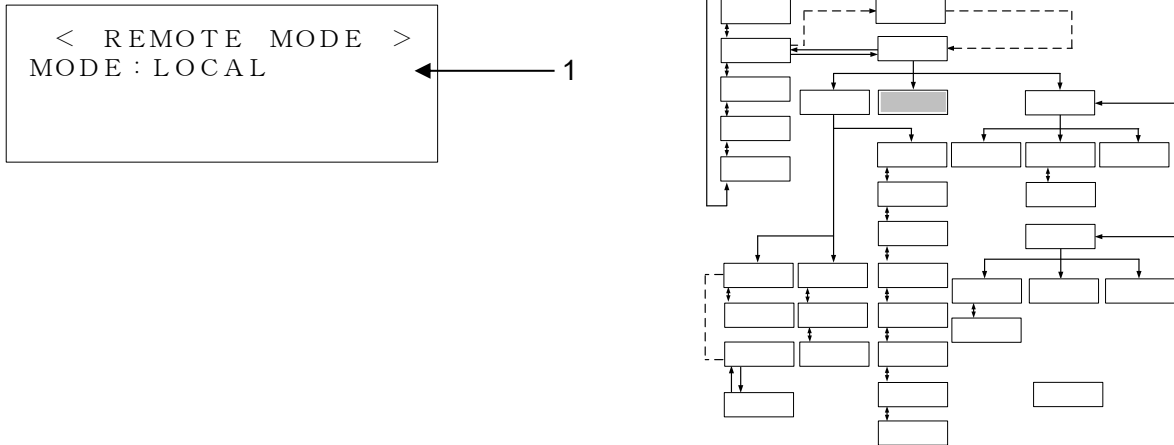

Figure 5-27 Mode Selection screen

Table 5-24 Mode Selection screen

No.	Item	Descriptions	Setting Range	Factory Default
1	MODE	<p>Allows the selection of communication mode.</p> <p>LOCAL: System start/stop and TEMP SP value setting is available only from the operation display panel.</p> <p>DIO REMOTE: System start/stop is allowed only through contact signal. When Analog Communication option is provided, TEMP SP value setting is available through analog signal.</p> <p>SER REMOTE: System start/stop and TEMP SP value setting is available only through serial RS-485 communication.</p> <p>DNET REMOTE*1: System start/stop and TEMP SP value setting is available only through Device Net communication.</p>	<p>LOCAL</p> <p>DIO REMOTE</p> <p>SER REMOTE</p> <p>DNET REMOTE*1</p>	LOCAL

[Tips]

It is displayed only if the Device Net Communication (optional) is provided (*1).

[▲] or [▼] key is used for selecting “Item” and pressing the [ENT] key enables to select the setting.

5.3.25 Maintenance screen 1

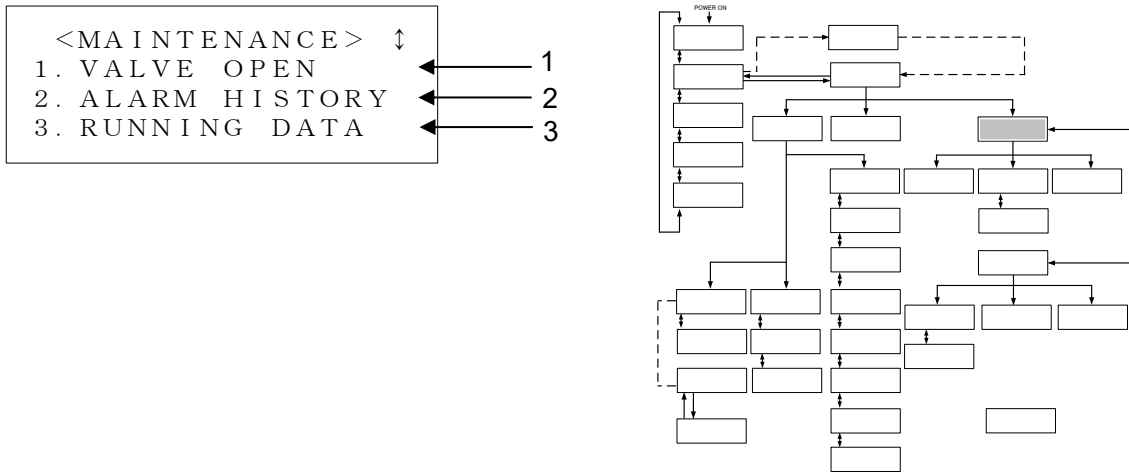

Figure 5-28 Maintenance screen 1

Table 5-25 Maintenance screen 1

No.	Item	Descriptions
1	VALVE OPEN	Switches to the “Maintenance Item screen 3” with the press of the [ENT] key.
2	ALARM HISTORY	Switches to the “Maintenance Item screen 4” with the press of the [ENT] key.
3	RUNNING DATA	Switches to the “Maintenance Item screen 5” with the press of the [ENT] key.

[Tips]

[▲] or [▼] key is used for selecting “Item” and moves to other Maintenance screens. Pressing the [ENT] key enables to change the setting or set value.

5.3.26 Maintenance screen 2

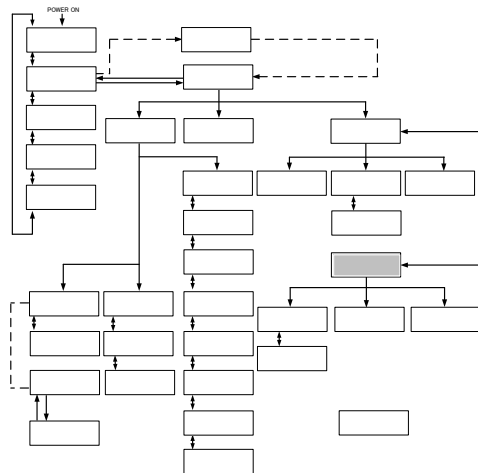

Figure 5-29 Maintenance screen 2

Table 5-26 Maintenance screen 2

No.	Item	Descriptions
1	MONITOR	Switches to the “Maintenance Item screen 6” with the press of the [ENT] key.
2	AUTO PURGE*1	Switches to the “Maintenance Item screen 8” with the press of the [ENT] key.
3	DI ACC RESET*2	Switches to the “Maintenance Item screen 9” with the press of the [ENT] key.

[Tips]

It is displayed only if the Circulating Fluid Automatic Collector (optional) is provided (*1).

It is displayed only if the DI Control Kit (optional) is provided (*2).

[▲] or [▼] key is used for selecting “Item” and moves to other Maintenance screens. Pressing the [ENT] key enables to change the setting or set value.

5.3.27 Maintenance screen 3

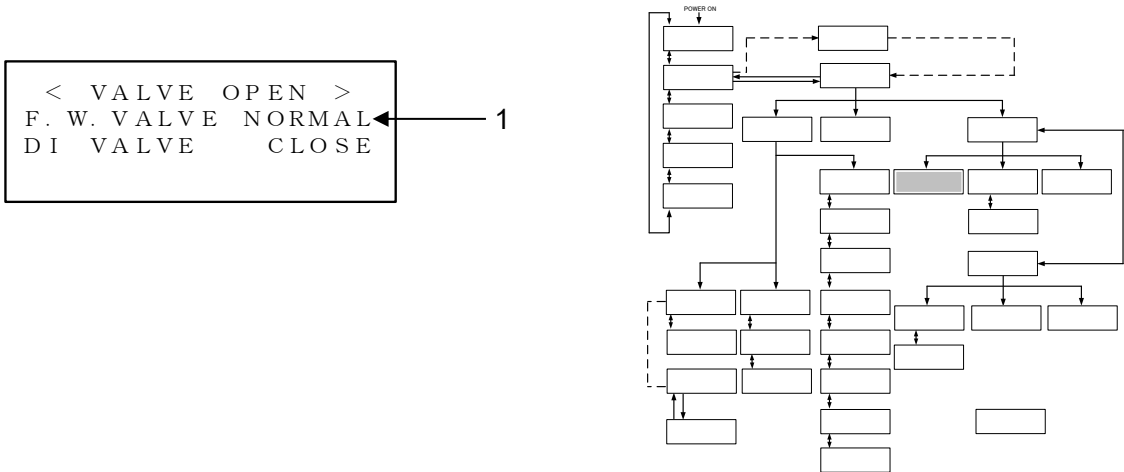

Figure 5-30 Maintenance screen 3

Table 5-27 Maintenance screen 3

No.	Item	Setting Range	Descriptions
1	VALVE*1	NORMAL	The proportional valve will be at the initial opening.
		OPEN	The proportional valve is opened forcefully.
2	DI VALVE*2	OPEN	The solenoid valve for DI circuit is opened forcefully.
		CLOSE	The solenoid valve for DI circuit is closed forcefully.

[Tips]

If you move the screen from "Maintenance screen 3", the forced operation of the solenoid valve will be canceled.

*1 Cannot be operated while running.

*2 It is displayed only if the DI Control Kit (optional) is provided.

For other options, "N/A" is displayed on the screen.

5.3.28 Maintenance screen 4

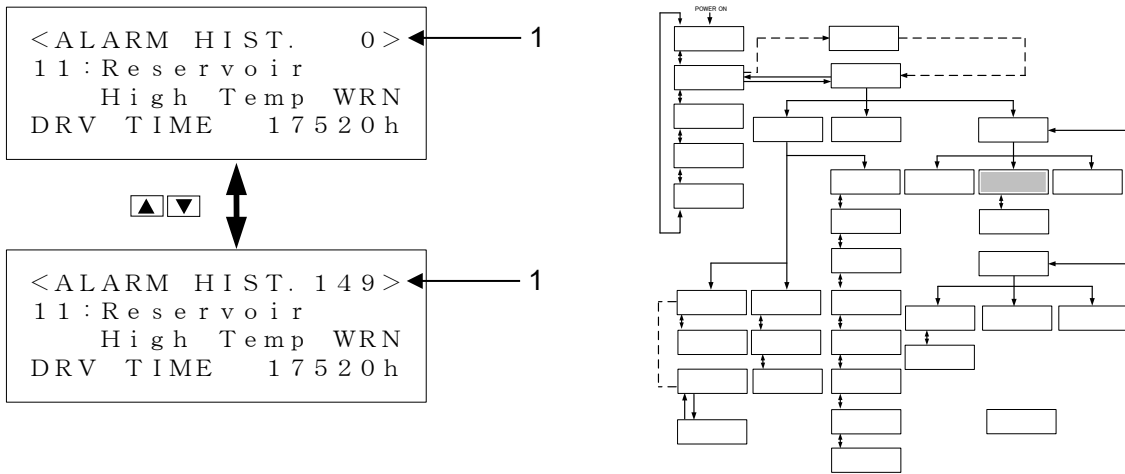

Figure 5-31 Maintenance screen 4

Table 5-28 Maintenance screen 4

No.	Item	Descriptions
1	ALARM HIST.	Data recording stores up to 150 pieces of alarm history data. If there are 150 or more pieces of data, the alarm history data is to be deleted in order of oldest data.

5.3.29 Maintenance screen 5

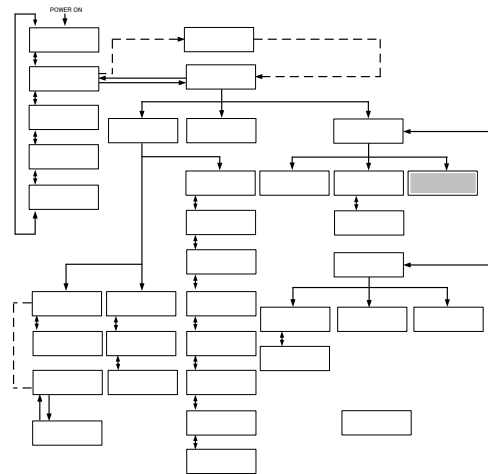
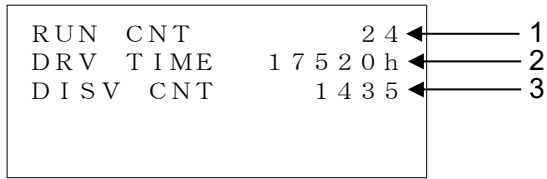

Figure 5-32 Maintenance screen 5

Table 5-29 Maintenance screen 5

No.	Item	Descriptions
1	RUN CNT	Number of times of operation on the system.
2	DRV TIME	Operating time on the system.
3	DISV CNT*1	Number of times that the solenoid valve for DI circuit is activated.

[Tips]

*1 It is displayed only if the DI Control Kit (optional) is provided.
 For other options, "N/A" is displayed on the screen.
 If you move the screen from "Maintenance screen 3",
 the forced operation of the solenoid valve will be canceled.

5.3.30 Maintenance screen 6

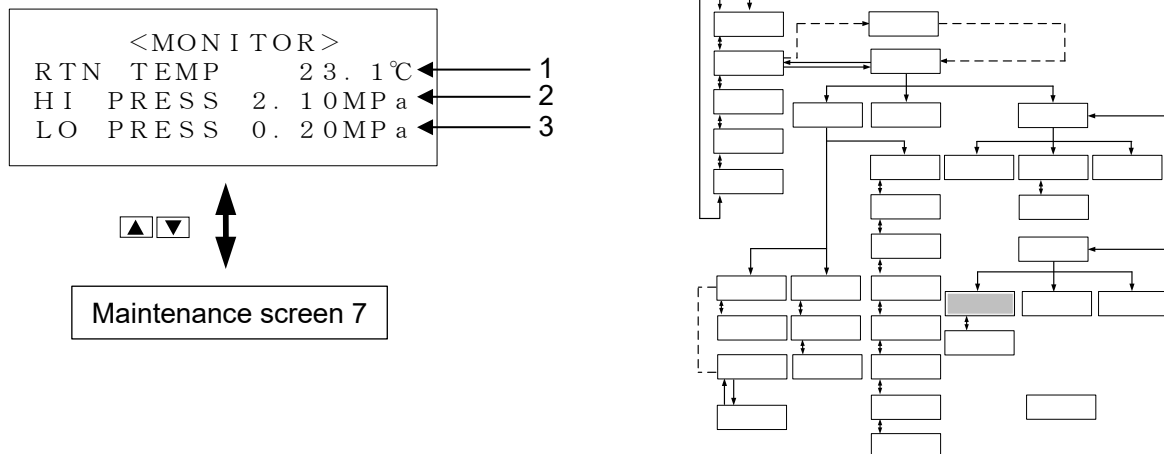

Figure 5-33 Maintenance screen 6

Table 5-30 Maintenance screen 6

No.	Item	Descriptions
1	RTN TEMP	Return temperature of circulating fluid.
2	HI PRESS	High pressure of refrigerant circuit.
3	LO PRESS	Low pressure of refrigerant circuit.

5.3.32 Maintenance screen 7

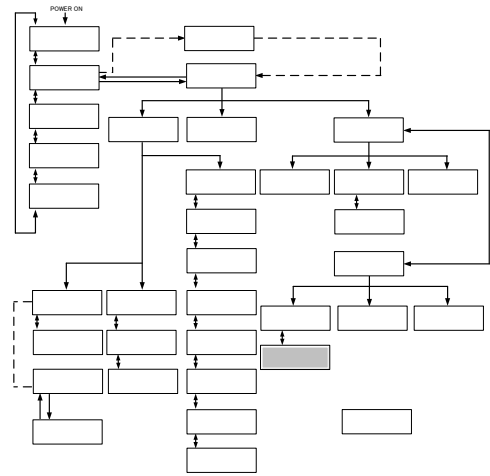
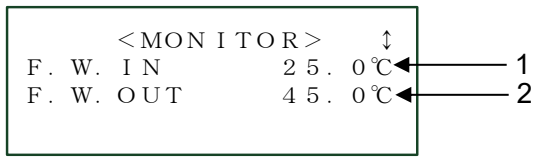

Figure 5-34 Maintenance screen 7

Table 5-31 Maintenance screen 7

No.	Item	Descriptions
1	F.W. IN	Inlet temperature of facility water.
2	F.W. OUT	Outlet temperature of facility water.

5.3.33 Maintenance screen 8

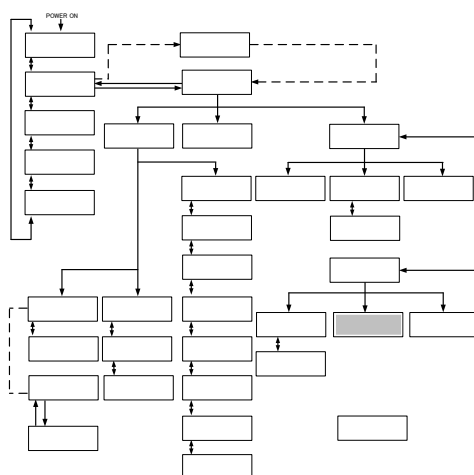
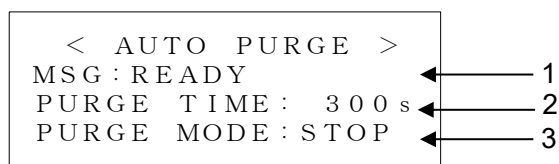

Figure 5-35 Maintenance screen 8

When MSG is “READY”, Start/Stop of circulating fluid automatic recovery is available.

Table 5-32 Maintenance screen 8

No.	Item	Descriptions
1	MSG	Indicates the status of circulating fluid automatic recovery. READY: Ready to collect. PURGE START : During recovery. FINISH: Recovery finished normally. TIME OUT: Recovering time exceeds setting value. IN RUNNING: This product during operation. ALARM : Alarm raised to this product. TEMP OUT: Circulating fluid temp. is out of range for starting recovery.
2	PURGE TIME	Setting value of PURGE TIME.
3	PURGE MODE	Start/Stop circulating fluid automatic recovery. After press [ENT] key, pressing either [▲] or [▼] key to select Start/Stop. Then automatic recovery Start/Stop is available after pressing [ENT] key to fix the setting. START : Start recovery. STOP : Stop recovery.

[Tips]

It is displayed only if the Circulating Fluid Automatic Collector (optional) is provided.

5.3.34 Maintenance screen 9

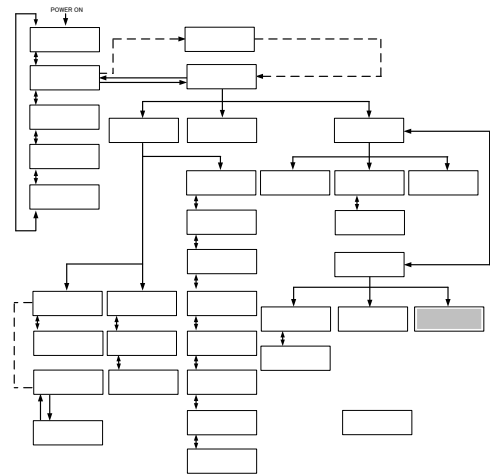
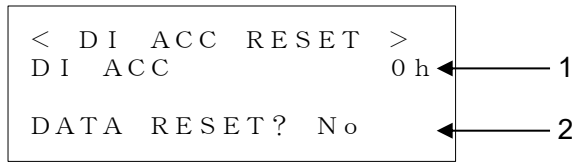

Figure 5-36 Maintenance screen 9

Table 5-33 Maintenance screen 9

No.	Item	Descriptions
1	DI ACC	Accumulated time that the solenoid valve for DI circuit is activated.
2	DATA RESET?	Allows to reset DI ACC. After press [ENT] key, pressing either [▲] or [▼] key to select Yes/No. Then Reset/Not reset DI ACC after pressing [ENT] key to fix the setting. Yes : Reset DI ACC. No : Not reset DI ACC.

[Tips]

It is displayed only if the DI Control Kit (optional) is provided.

5.3.35 System Information screen

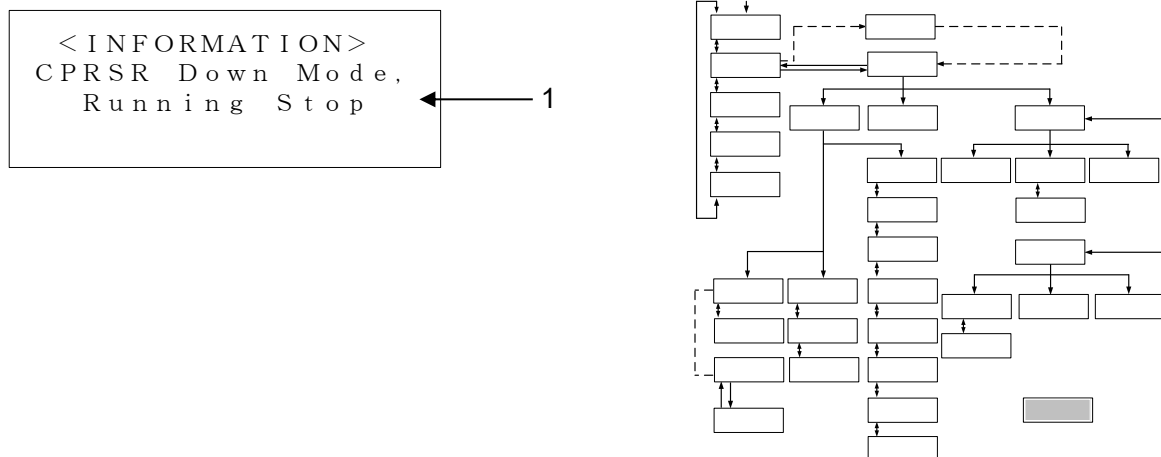

Figure 5-37 System Information screen

The “System Information screen”, as shown above, may be displayed upon system Start/Stop.

Table 5-34 System Information screen

No.	Item	Descriptions
1	INITIALIZE MODE (CONTROL VALVE) (RESERVOIR)	Operation prepares mode after turning on the main breaker. System operation is disabled if this message is displayed. CONTROL VALVE: Positioning of the electronic expansion valve is performed. RESERVOIR: The circulating fluid flows in this product through the internal pump.
	Pump Up Mode Running Start	If your piping is supplied with an insufficient amount of the circulating fluid at system startup, the circulating pump in this product activates (repeating ON/OFF) to replenish piping with the circulating fluid. Continuous operation is initiated once piping is replenished with the fluid.
	CPRSR Down Mode. Running Stop	Compressor operation remains for approx. 20 seconds after circulating pump stops for the protection of the compressor at the time of system shutdown.

5.4 Examples of System Operation

5.4.1 Example 1: Circulating fluid set temperature is changed from 20.0 deg C to 34.1 deg C.

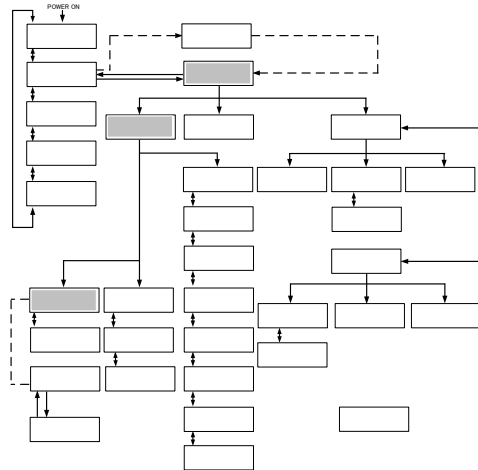

Figure 5-38 Change of Set Temperature from 20 deg C to 34.1 deg C

1. Press the [SEL] key to display the "Menu screen".

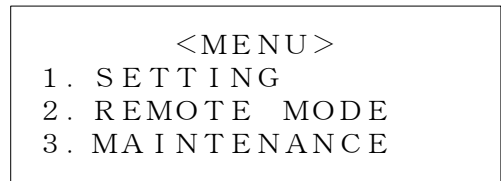

Figure 5-39 Menu screen

2. With the use of the arrow keys ([▲] or [▼]), move the cursor to "1. SETTING" and press the [ENT] key.

The "Setting screen" is displayed.



Figure 5-40 Setting screen

3. With the use of the arrow keys ([▲] or [▼]), move the cursor to "1. CONTROL SET" and press the [ENT] key.

The "Control Setting screen 1" is displayed.

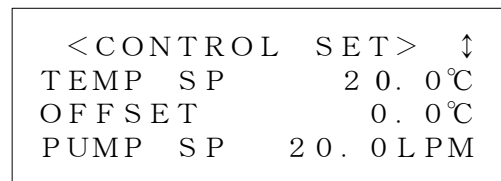

Figure 5-41 Control setting screen1

4. Press the [ENT] key.

The cursor is now appears on the current value for TEMP SP, which enables change of the temperature set value.

```
<CONTROL SET>  ↑
TEMP SP      █ 2 . 0°C
OFFSET       0 . 0°C
PUMP SP      20 . 0 LPM
```

Figure 5-42 Control Setting screen 1: Cursor Display

5. Use the arrow keys ([▲], [▼] or [▶]) to change the temperature to 34.1 deg C.

[▲] key: Used to add one value on which the cursor is placed.

[▼] key: Used to subtract one value on which the cursor is placed.

[▶] key: Used to move the cursor to the right.

```
<CONTROL SET>  ↑
TEMP SP      34 . █°C
OFFSET       0 . 0°C
PUMP SP      20 . 0 LPM
```

Figure 5-43 Control Setting screen 1: Change of set value

6. Press the [SEL] key to display the “Menu screen 1”.

```
<CONTROL SET>  ↑
TEMP SP      34 . 1°C
OFFSET       0 . 0°C
PUMP SP      20 . 0 LPM
```

Figure 5-44 Control Setting screen 1: Setting Confirmation

5.4.2 Example 2: Communication mode is switched from “LOCAL” to “SER REMOTE”.

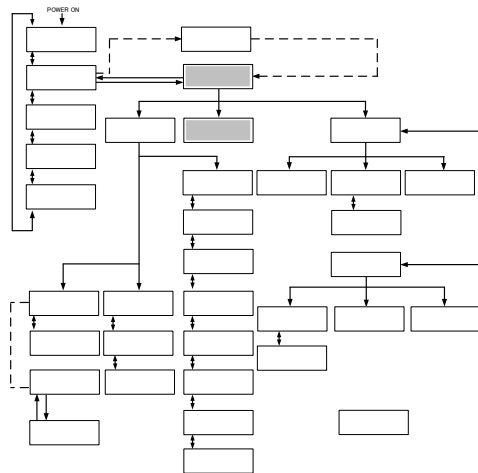

Figure 5-45 Switching of communication mode from “LOCAL” to “SER REMOTE”

1. Press the [SEL] key to display the “Menu screen”.

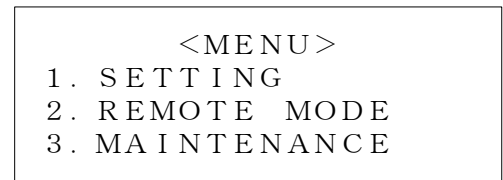

Figure 5-46 Menu screen

2. With the use of the arrow keys ([▲] or [▼]), move the cursor to “2. REMOTE MODE” and press the [ENT] key.
The “Mode Selection screen” is displayed.



Figure 5-47 Mode Selection screen

3. Press the [ENT] key
The name of current mode “LOCAL” flashes and enables the setting to be switched.



Figure 5-48 Mode Selection screen

4. Use the arrow keys ([▲] or [▼]), to select “SER REMOTE”.

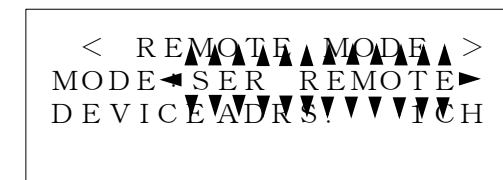

Figure 5-49 Mode Selection screen

5. Press the [ENT] key.

5.4.3 Example 3: PUMP IV is switched from “FLOW” to “FREQ”.

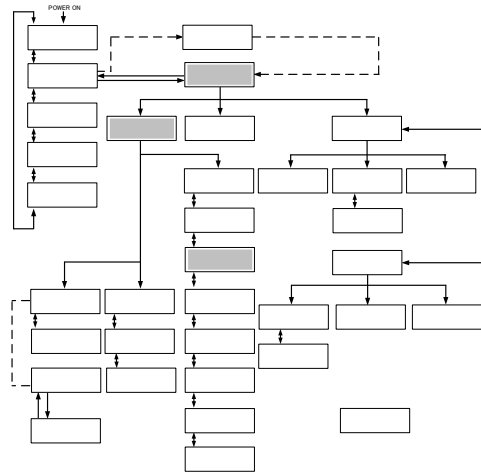

Figure 5-50 Switching of pump operation from FLOW to FREQ

1. Press the [SEL] key to display the “Menu screen”.

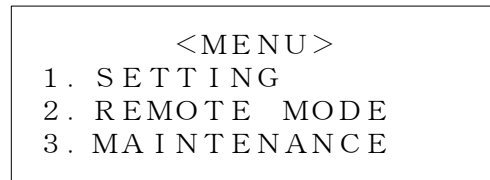

Figure 5-51 Menu screen

2. With the use of the arrow keys ([▲] or [▼]), move the cursor to “1. SETTING” and press the [ENT] key.

The “Setting screen” is displayed.



Figure 5-52 Setting screen

3. With the use of the arrow keys([▲] or [▼]), move the cursor to “3.INITIAL SET” and press the [ENT] key.

The “Initial setting screen 1”is displayed.

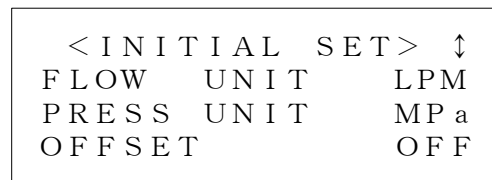

Figure 5-53 Initial Setting screen 1

4. With the use of the arrow keys([▲] or [▼]), move the cursor to “Initial Setting screen 3”.

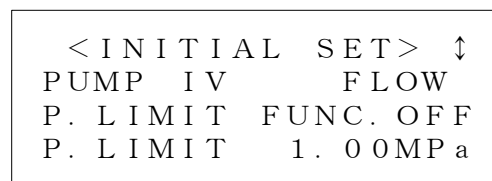

Figure 5-54 Initial Setting screen 3

- 5.** With the use of the arrow keys([▲] or [▼]), move the cursor to “PUMP IV” and press the [ENT] key.
The name of current setting “FLOW” flashes and enable to switch the setting.

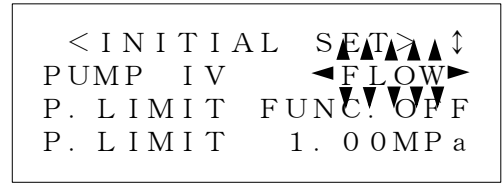

Figure 5-55 Initial Setting screen 3

- 6.** With the use of the arrow keys([▲] or [▼]), to select “FREQ”

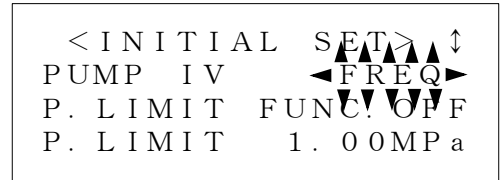

Figure 5-56 Initial Setting screen 3

- 7.** Press the [ENT] key.

Chapter 6 Error Message and Troubleshooting

6.1 Error Message

The following are to be performed in the event of an error in this product.

- The “ALARM” lamp comes on.
- Alarm buzzer comes on.
- The “Alarm Display screen” is displayed on the LCD screen.
- Error signal is issued through external communication.
(See section 8.1.5 “Communication specification” in Chapter 8 Appendix for details on page 8-10).
- This product is brought to a stop forcefully according to error types.

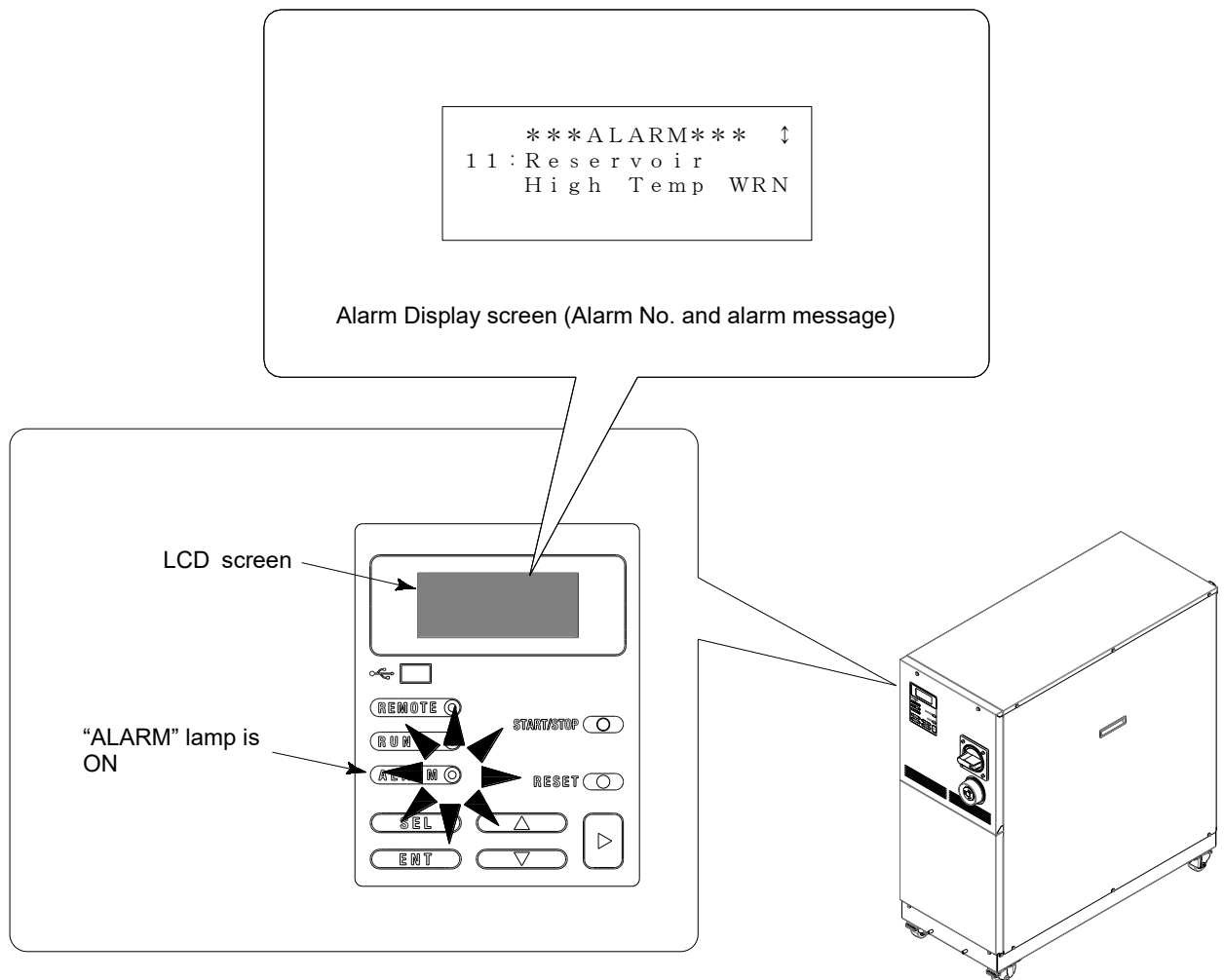

Figure 6-1 Error Occurrence

6.2 Troubleshooting

The procedure for error recovery varies with alarm types.

- Alarm Code.01, 03 to 16, 19 to 21, 24, 25, 27 to 30, 32:
Eliminate the error cause. Press the [RESET] key on the operation display panel or power cycle the main breaker to enable error recovery to take effect.
- Alarm Code.22:
Eliminate the error cause and power cycle the main breaker to enable error recovery to take effect.
- Alarm Code.23:
Automatic error recovery is implemented upon elimination of the error.
- Alarm Code.24:
This is an alarm for accessories (optional).
No alarm of this type is issued if the system is fitted without accessories.

Table 6-1 Troubleshooting (1/3)

Code	Error message	System condition	Cause	Remedies
01	Water Leak Detect FLT	Stop	The fluid is pooled at the base of this product.	Check for fluid leak.
03	RFGT High Press FLT	Stop	The pressure of the refrigerant circuit exceeded the specified value. <Specified value> 13MPa	Check that facility water is being supplied to this product.
04	CPRSR Overheat FLT	Stop	The temperature in the compressor was excessive. <Specified value> 110 deg C	Check that facility water is being supplied to this product.
05	Reservoir Low Level FLT	Stop	An insufficient amount of the circulating fluid is observed in the tank.	Refill the circulating fluid.
06	Reservoir Low Level WRN	Continued	An insufficient amount of the circulating fluid is observed in the tank.	Refill the circulating fluid.
07	Reservoir High Level WRN	Continued	An excessive amount of the circulating fluid is observed in the tank.	Drain the circulating fluid.
08	Temp. Fuse Cutout FLT	Stop	The circulating fluid tank was raised in temperature. <Specified value> HRZC***-WS/W1S : Thermal fuse cutout temperature : 98 deg C HRZC***-W2S : Thermal fuse cutout temperature : 72deg C	Check the load specification. Replacement of the thermal fuse is required. Call the supplier for service.
09	Reservoir High Temp. FLT	Stop	The temperature of the circulating fluid exceeded the specified value. <Specified value> HRZC***-WS/W1S : 95 deg C HRZC***-W2S : 65 deg C	Check the load specification.

Table 6-1 Troubleshooting (2/3)

Code	Error message	System condition	Cause	Remedies
10	Return High Temp WRN	Continued	The temperature of the circulating fluid exceeded the specified value. <Specified value> HRZC010-WS : 110 deg C HRZC010-W1S: 100 deg C HRZC010-W2S: 80 deg C	Check the circulating fluid flow rate, load specification.
11	Reservoir High Temp. WRN	Continued	The temperature of the circulating fluid exceeded your set value. <Setting range> HRZC002-WS/W1S : -10.0~93.0 deg C HRZ004/008/010-WS/W1S/W2S : -20.0~93.0 deg C HRZC***-W2S : 10.0~63.0 deg C <Factory default> HRZC***-WS/W1S : 93.0 deg C HRZC***W2S : 63.0 deg C	Reset the setting temperature.
12	Return Low Flow FLT	Stop	The flow rate of the circulating fluid falls below specified value. <Specified value> 6L/min	<ul style="list-style-type: none"> · Check that the external valve is opened. · Prepare a thicker external pipe or install bypass piping.
13	Return Low Flow WRN	Continued	The flow rate of the circulating fluid falls below your set value. <Specified value> 8.0 to 40.0L/min <Factory default> 8.0L/min	Reset the setting flow rate.
14	Heater Breaker Trip FLT	Stop	The heater power line protection device was activated.	Check the power supply is within specifications.
15	Pump Breaker Trip FLT	Stop	The pump power line protection device was activated.	Check the power supply is within specifications.
16	CPRSR Breaker Trip FLT	Stop	The compressor power line protection device was activated	Check the power supply is within specifications.
16	CPRSR Breaker Trip FLT	Stop	The breaker for the compressor power line was tripped.	Check that the power supply to this product is compliant with the specification.
19	FAN Motor Stop WRN	Continued	The ventilating fan came to a stop.	Check that the air vent on the back of the system is not blocked off.
20	Internal Pump Time Out WRN	Continued	The internal pump was under conditions of continuous operation over a specified time. <Specified time>10min	Check for fluid leak from circulating fluid piping in customer system.
21	Controller Error FLT	Stop	An error was detected in the control system.	Contact the system supplier for request of inspection and repair.
22	Memory Data Error FLT	Stop	An error was detected in data stored in the controller of this product.	<ul style="list-style-type: none"> · Turn the main breaker OFF and ON to recover from the error. · Contact the system supplier for request of inspection and repair.

Table 6-1 Troubleshooting (3/3)

Code	Error message	System condition	Cause	Remedies	
23	Communication Error	0001	Continued	An interruption of serial communication occurred in this product.	<ul style="list-style-type: none"> • Contact the system supplier for request of inspection and repair.
		8000	Continued	An interruption of serial communication occurred between this product and customer system.	<ul style="list-style-type: none"> • Check for disconnection of the communication connector from this product.
24	DI Low Level WRN	Continued	The DI level of the retuning circulating liquid is lower than your set value (Optional). <Setting range> 0.0 to 2.0MΩ <Factory default> 0.0MΩ	<ul style="list-style-type: none"> • Lower the setting for resistivity. • Replacement of the DI filter is required 	
25	Pump Inverter Error FLT	Stop	An error was detected in the inverter for circulating pump.	Contact the system supplier for request of inspection and repair.	
27	F.Water High Temp FLT	Stop	The temperature of the facility water exceeded the specified value. <Specified value> 60 deg C	Check the facility water is supplied to this product.	
28	CPRSR INV Error FLT	Stop	An error was detected in the inverter for compressor.	Contact the system supplier for request of inspection and repair.	
29	RFGT Low Press FLT	Stop	The refrigerant pressure falls below the specified value. <Specified value> 0.1MPa	Contact the system supplier for request of inspection and repair.	
30	F.Water High Temp WRN	Continued	The temperature of the facility water exceeded the set value. <Setting range> 45.0 to 60.0 deg C <Factory default> 55.0 deg C	Reset the setting temperature.	
32	Reservoir Low Temp. WRN	Continued	The temperature of the circulating fluid below set value. <Setting range> HRZC002-WS/W1S : -15.0~90.0 deg C HRZC004/008/010-WS/W1S : -25.0~90.0 deg C HRZC***-W2S : 5.0~60.0 deg C <Factory default> HRZC002-WS/W1S : -15.0 deg C HRZC004/008/010-WS/W1S : -25.0 deg C HRZC***-W2S : 5.0 deg C	Reset the setting temperature.	

Chapter 7 System Maintenance

7.1 Water Quality Management

⚠ CAUTION



Only designated circulating fluid is permitted to use for this product. Potential system failure and fluid leakage may occur if disregarded, which results in electric shock, ground fault, and/or freeze. Be sure to use water compliant with water quality standards in the table below for ethylene glycol aqueous solution and facility water.

Table 7-1 Water Quality Standards for Water

	Substance	Facility water spec.	Circulating water spec.
Standards	pH (25 deg C)	6.5 to 8.2	6.0 to 8.0
	Electrical conductivity (25 deg C) (µs/cm) *Circulating fluid 1 to 500	100 to 800	0.5 to 300
	Chloride ion (mgCl-/L)	Max. 200	Max. 50
	Sulfate ion (mgSO ₄ ²⁻ /L)	Max. 200	Max. 50
	Acid consumption (pH4.8) (mgCaCO ₃ /L)	Max. 100	Max. 50
	Total hardness (mgCaCO ₃ /L)	Max. 200	Max. 70
	Calcium hardness (mgCaCO ₃ /L)	Max. 150	Max. 50
	Ionic silica (mgSiO ₂ /L)	Max. 50	Max. 30
	Iron (mgFe/L)	Max. 1.0	Max. 0.3
	Copper (mgCu/L)	Max. 0.3	Max. 0.1
	Sulfide ion (mgS ²⁻ /L)	Not be detected	
	Ammonium ion (mgNH ₄ ⁺ /L)	Max. 1.0	Max. 0.1
	Residual chlorine (mgCl/L)	Max. 0.3	Max. 0.3
	Free carbon dioxide (mgCO ₂ /L)	Max. 4.0	Max. 4.0
Filtering (µm)	Max.5		

*According to the water quality guideline for refrigeration air-conditioning equipment: JRA-GL-02-1994

CAUTION



If the periodic inspection finds a nonconforming substance in the facility water, clean the facility water circuit and recheck the quality of the facility water.

7.2 Inspection and Cleaning

⚠ WARNING



Do not touch any electrical parts with wet hands. Keep wet hands away from electrical parts. Potential electric shock can occur if disregarded. Keep this product from water. Potential electric shock or fire can occur if disregarded.

⚠ WARNING



If the inspection and cleaning require the removal of the panel, be sure to re-attach the panel upon completion. Potential personal injury or electric shock may occur if operated with the panel opened or removed.

7.2.1 Daily inspection

Table 7-2 Daily Inspection

Inspection item	Inspection method	
Installation condition	Check of the condition of system installation	No heavy object is placed on this product. This product should not be subjected to external force.
		Temperature and humidity fall within the specified range.
Fluid leak	Check of the piping connector section	No leakage of facility water and circulating fluid from the piping connector section.
Fluid level	Reading of the level of the circulating fluid	Level falls within the circulating fluid specified level between “High” and “Low”.
Operation display panel	Display check	Clarity of letters and numbers on the LCD display should be assured.
	Function check	[RUN] lamp is ON.
Circulating fluid temperature	Confirm the reading on the LCD screen	Temperature should be within setpoint.
Refrigerant pressure	Reading of the refrigerant pressure gauge	Value of “HI PRESS” in “Maintenance screen 6” (page 5-32) should be in the following range. 5.0 to 9.0 MPa
Supply pressure of circulating fluid	Confirm the reading on the LCD screen	Readings should not have deviated much from last inspection.
Circulating fluid flow rate	Confirm the reading on the LCD screen	Reading should not have deviated much from last inspection.
Operating condition	Operating condition check	No abnormal noise, vibration, odor and smoke.
Facility water	Check of the facility water	Temperature, flow rate, and pressure fall within the specified range.
Circulating fluid supply port cap	Check by providing manual tightening	No looseness.

7.2.2 Quarterly inspection



⚠ WARNING	
	<p>Be sure to lockout/tagout this product before carrying out the quarterly inspection. See section 1.6.3 “Lockout/Tagout” in “Chapter 1 Safety” for details on page 1-13.</p>

Table 7-3 Quarterly Inspection

Inspection item	Inspection method
Circulating fluid	Circulating fluid is to be drained for check. Fluid should be free of particles, moisture*1, and foreign substances.
	For ethylene glycol solution, confirm that the concentration falls within the specified range.
Facility water	Facility water quality should fall within the standards specified.
Ventilation hole and electrical parts	No particles and dust should be present.

CAUTION	
	<p>Moisture trapped in the fluorinated fluid (*1) freezes in the heat exchanger element and piping, which may lead to system failure.</p>

■ Cleaning of the product

If the product is dirty, clean it with a dry wipe or air blow.

7.3 Storage

The following should be performed for system long-term storage.

- 1.** Drain the circulating fluid. See section 7.3.1 “Draining of circulating fluid out of tank” for details on page 7-4.
- 2.** Drain the facility water. See section 7.3.2 “Draining of facility water” for details on page 7-5.
- 3.** Cover the system with a plastic sheet for storage.

7.3.1 Draining of circulating fluid out of tank

⚠ CAUTION

! Use a clean container for circulating fluid recovery. Reuse of the recovered circulating fluid with contaminants will cause insufficient cooling and system failure. Be sure to wait until the circulating fluid obtains room temperature for its draining. Potential burns and dew intrusion may occur if disregarded.

1. Prepare the container for circulating fluid recovery at the back of this product.

2. Connect the drain hoses to the main and sub tank drain ports each. Insert the tip of the hose into the container.

- Prepare a drain hose (Rc3/8-diameter) on your responsibility.

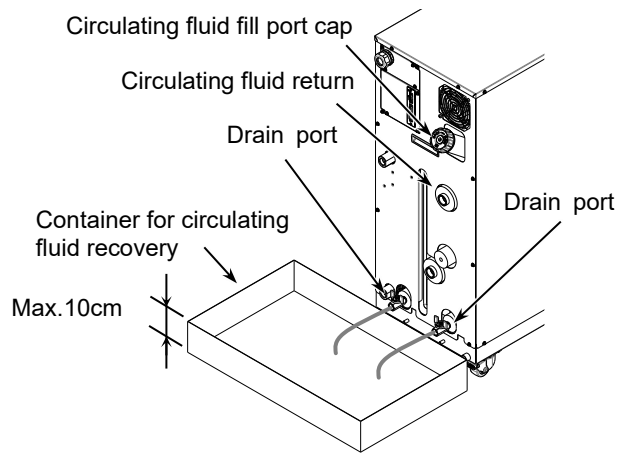

Figure 7-1 Container for Circulating Fluid Recovery

3. Remove the cap of the circulating fluid fill port.

4. Open the valves of the main and sub tank drain ports to drain the circulating fluid.

5. Apply air purge from the the circulating fluid return to push the circulating fluid remaining in the heat exchange back in the tank and drain it.

CAUTION

⊘ If the recovered circulating fluid is contaminated by foreign substances, completely remove them. Do not reuse contaminated fluid. Potential insufficient cooling, system failure and froth in the circulating fluid may occur if disregarded.

CAUTION

! Recovered circulating fluid must be sealed in a container to prevent contamination from moisture or foreign substances. Stored in a cool, dark place. Keep it from flame.

6. Upon completion of fluid draining, close the valves of the main and sub tank drain ports.

7. Add plugs to seal off ports on the rear of this product.

- See section 7.3.2 “Draining of facility water” for plug attachment.

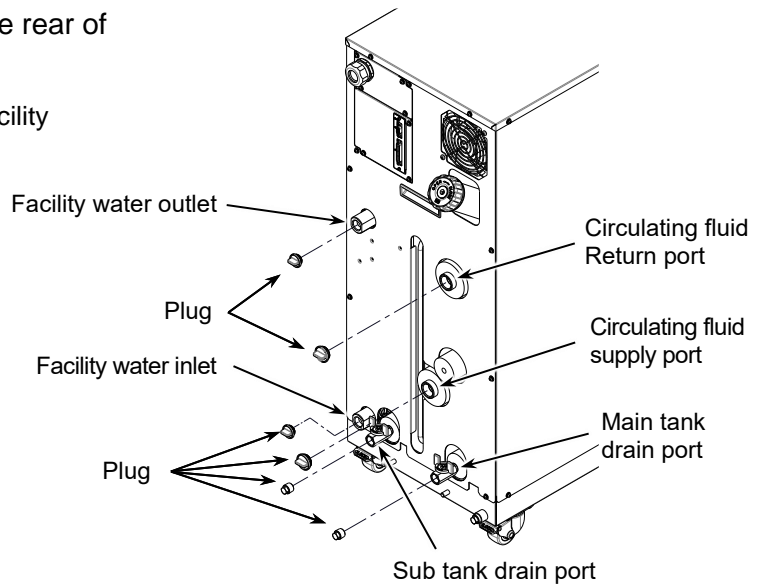

Figure 7-2 Plug Attachment

7.3.2 Draining of facility water

⚠ CAUTION

! Be sure to drain the facility water only when it is at room temperature. Trapped fluid inside the system can still be hot. Potential burns can occur if disregarded.

1. Place the drain pan underneath the piping connections on the rear of this product.

- 7L-capacity or bigger drain pan is required.

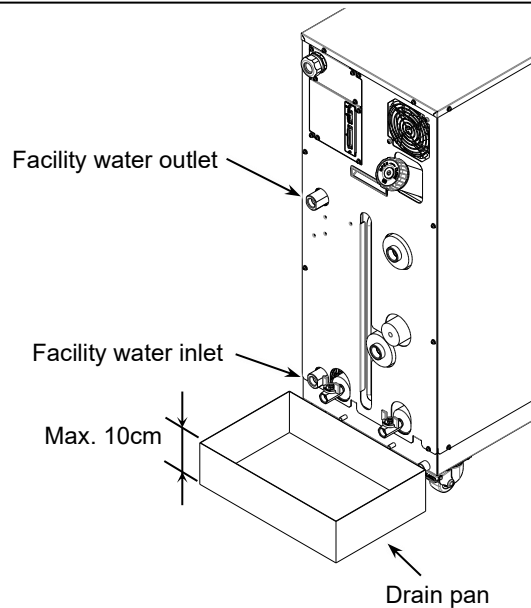

Figure 7-3 Drain Pan Attachment

- 2.** Remove facility water piping.
- Remove the joints such as unions if present.

-
- 3.** Drain the facility water using the facility water inlet port.

7.4 Periodic Replacement Parts

Replacement of consumables listed in the following table is recommended. Contact the system supplier for request of part replacement.

Table 7-4 Periodic Replacement Part List

Part	Recommended replacement cycle
Internal pump	Every 3 yrs
Circulating pump	Every 3 yrs
Ventilating fan	Every 3 yrs
Inverter Cooling Fan	Every 3 yrs

*Note: A replacement cycle may vary with your usage condition.

Chapter 8 Appendix

8.1 Specification

8.1.1 System specification

■ Specification for fluorinated fluid

Table 8-1 Specification for Fluorinated Fluid

Model		HRZC002-WS	HRZC004-WS	HRZC008-WS	HRZC010-WS	
Cooling method		Water cooled refrigerant				
Cooling capacity* ¹ (50Hz/60Hz)	kW	2.0	4.0	8.0	10.0	
Operating temperature range	deg C	-10 to 90	-20 to 90			
Temperature stability	deg C	±0.1* ²				
Circulating fluid		Galden [®] HT135* ³ Fluorinert [™] FC-3283* ³ (-20 to 40 deg C) Galden [®] HT200* ³ Fluorinert [™] FC-40* ³ (20 to 90 deg C)				
		(No intrusion of foreign body)				
Refrigerant		R744 (CO ₂ , GWP1)				
Refrigerant charge	kg	1.0				
Pump capacity* ⁴	MPa	0.65 (At 20L/min) (94[PSIG] At 5.3 [gal/min])			0.72 (At 20L/min) (104[PSIG] At 5.3 [gal/min])	
Main Tank capacity* ⁵	L	Approx.15 (4 [gal])				
Sub Tank capacity* ⁶	L	Approx.16 (4.2 [gal])				
Circulating fluid port		Rc 3/4				
Facility water	deg C /MPa	10 to 30 / 0.3 to 0.7 (45 to 100 [PSIG])				
Facility water required flow rate	Rated condition* ⁹	L/min	4 (1.1 [gal/min])	7 (1.8 [gal/min])	14 (3.7 [gal/min])	15 (4 [gal/min])
	Temp. changing condition* ¹⁰	L/min	10 (2.6 [gal/min])	12 (3.2 [gal/min])	15 (4 [gal/min])	15 (4 [gal/min])
Facility water port		Rc 1/2				
Power supply		3-phase 50/60Hz AC200/200 to 208V±10%				
Breaker size	A	20	30			
Dimensions* ⁷	mm	W380xD870xH950 (W14.96xD34.25xH37.40 [inch])				
Weight* ⁸	kg	175 (386 [lbs])				
Communication		Serial RS-485 (D-sub 9pin), Contact signal (D-sub 25pin)				

*1: The capacity is derived under the conditions that the circulating fluid temp is 20 deg C, the facility water temp. is 25 deg C and that the circulating fluid flow rate is obtained at a specified flow rate of pump capacity.

*2: This is a system output temperature, with flow rate defined in pump capacity secured, when stabilized with no disturbance. Its upper limit may be violated if an insufficient amount of the circulating fluid is present or a disturbance to flow rate is observed.

*3: Galden[®] is a registered trademark of Solvay Solexis, and Fluorinert[™] is a trademark of U.S. 3M.

*4: The capacity is derived at the Outlet of this product when the circulating fluid temp. is at 20 deg C and the inverter operating at maximum frequency.

*5: This is a minimum amount of the fluid for operation of the Thermo Chiller outfitted with internal piping and heat exchanger in this product. Circulating fluid temp.: 20deg C

*6: For circulating fluid containment during line purge back or back flow, this is the volume of free space in Sub-Tank when fluid level is at "High" level. Main-Tank capacity is excluded.

*7: These are the dimensions of panels, which are derived without protrusions such as a breaker handle.

*8: This is the mass of the system when it contains no circulating fluid.

*9: The required flow rate when the cooling capacity load is applied under the condition in *1.

*10: Temporarily required flow rate when set temperature is changed under the facility water temp.25 deg C.

■ Specification for ethylene glycol solution

Table 8-2 Specification for ethylene glycol solution

Model		HRZC002-W1S	HRZC004-W1S	HRZC008-W1S	HRZC010-W1S	
Cooling method		Water cooled refrigerant				
Cooling capacity*1 (50Hz/60Hz)	kW	2.0	4.0	8.0	10.0	
Operating temperature range	deg C	-10 to 90	-20 to 90			
Temperature stability	deg C	±0.1*2				
Circulating fluid		Ethylene glycol aqueous solution 60%*3				
		(No intrusion of foreign body)				
Refrigerant		R744 (CO ₂ , GWP1)				
Refrigerant charge	kg	1.0				
Pump capacity*4	MPa	0.40 (At 20L/min) (58[PSIG] At 5.3 [gal/min])				
Main Tank capacity*5	L	Approx.15 (4 [gal])				
Sub Tank capacity*6	L	Approx.16 (4.2 [gal])				
Circulating fluid port		Rc 3/4				
Facility water	deg C /MPa	10 to 30 / 0.3 to 0.7 (45 to 100 [PSIG])				
Facility water required flow rate	Rated condition*9	L/min	4 (1.1 [gal/min])	6 (1.6 [gal/min])	14 (3.7 [gal/min])	15 (4 [gal/min])
	Temp. changing condition*10	L/min	10 (2.6 [gal/min])	12 (3.2 [gal/min])	15 (4 [gal/min])	15 (4 [gal/min])
Facility water port		Rc 1/2				
Power supply		3-phase 50/60Hz AC200/200 to 208V±10%				
Breaker size	A	20	30			
Dimensions*7	mm	W380xD870xH950 (W14.96xD34.25xH37.40 [inch])				
Weight*8	kg	175 (386 [lbs])				
Communication		Serial RS-485 (Dsub-9pin) , Contact signal (Dsub-25pin)				

*1: The capacity is derived under the conditions that the circulating fluid temp is 20 deg C, the facility water temp. is 25 deg C and that the circulating fluid flow rate is obtained at a specified flow rate of pump capacity.

*2: This is a system output temperature, with flow rate defined in pump capacity secured, when stabilized with no disturbance. Its upper limit may be violated if an insufficient amount of the circulating fluid is present or a disturbance to flow rate is observed.

*3: Pure ethylene glycol needs dilution with fresh water before use.

Ethylene glycol with additives such as preservatives is NOT available. It not only reduces the performance, but also lead to failure.

*4: The capacity is derived at the Outlet of this product when the circulating fluid temp. is at 20 deg C and the inverter operating at maximum frequency.

*5: This is a minimum amount of the fluid for operation of the Thermo Chiller outfitted with internal piping and heat exchanger in this product. Circulating fluid temp.: 20 deg C

*6: For circulating fluid containment during line purge back or back flow, this is the volume of free space in Sub-Tank when fluid level is at "High" level. Main-Tank capacity is excluded.

*7: These are the dimensions of panels, which are derived without protrusions such as a breaker handle.

*8: This is the mass of the system when it contains no circulating fluid.

*9: The required flow rate when the cooling capacity load is applied under the condition in *1.

*10: Temporarily required flow rate when set temperature is changed under the facility water temp.25 deg C.

■ Specification for water

Table 8-3 Specification for water

Model		HRZC002-W2S	HRZC004-W2S	HRZC008-W2S	HRZC010-W2S	
Cooling method		Water cooled refrigerant				
Cooling capacity* ¹ (50Hz/60Hz)	kW	2.0	4.0	8.0	10.0	
Operating temperature range	deg C	10 to 60				
Temperature stability	deg C	±0.1* ²				
Circulating fluid		Water* ³ (No intrusion of foreign body)				
Refrigerant		R744 (CO ₂ , GWP1)				
Refrigerant charge	kg	1.0				
Pump capacity* ⁴	MPa	0.38 (At 20L/min) (55[PSIG] At 5.3 [gal/min])				
Main Tank capacity* ⁵	L	Approx.15 (4 [gal])				
Sub Tank capacity* ⁶	L	Approx.16 (4.2 [gal])				
Circulating fluid port		Rc 3/4				
Facility water	deg C /MPa	10 to 30 / 0.3 to 0.7 (45 to 100 [PSIG])				
Facility water required flow rate	Rated condition* ⁹	L/min	4 (1.1 [gal/min])	7 (1.8 [gal/min])	14 (3.7 [gal/min])	15 (4 [gal/min])
	Temp. changing condition* ¹⁰		10 (2.6 [gal/min])	12 (3.2 [gal/min])	15 (4 [gal/min])	15 (4 [gal/min])
Facility water port		Rc 1/2				
Power supply		3-phase 50/60Hz AC200/200 to 208V±10%				
Breaker size	A	20	30			
Dimensions* ⁷	mm	W380xD870xH950 (W14.96xD34.25xH37.40 [inch])				
Weight* ⁸	kg	175 (386 [lbs])				
Communication		Serial RS-485 (Dsub-9pin) , Contact signal (Dsub-25pin)				

*1: The capacity is derived under the conditions that the circulating fluid temp is 20 deg C, the facility water temp. is 25 deg C and that the circulating fluid flow rate is obtained at a specified flow rate of pump capacity.

*2: This is a system output temperature, with flow rate defined in pump capacity secured, when stabilized with no disturbance. Its upper limit may be violated if an insufficient amount of the circulating fluid is present or a disturbance to flow rate is observed.

*3: SMC recommends satisfying the water quality standards of the Japan Refrigeration and Air Conditioning Industry Association (JRA GL-02-1994/Cooling water system-Recirculation type-Make-up water) (See"7.1 Water Quality Management" for more details).

*4: The capacity is derived at the Outlet of this product when the circulating fluid temp. is at 20 deg C and the inverter operating at maximum frequency.

*5: This is a minimum amount of the fluid for operation of the Thermo Chiller outfitted with internal piping and heat exchanger in this product. Circulating fluid temp.: 20 deg C

*6: For circulating fluid containment during line purge back or back flow, this is the volume of free space in Sub-Tank when fluid level is at "High" level. Main-Tank capacity is excluded.

*7: These are the dimensions of panels, which are derived without protrusions such as a breaker handle.

*8: This is the mass of the system when it contains no circulating fluid.

*9: The required flow rate when the cooling capacity load is applied under the condition in *1.

*10: Temporarily required flow rate when set temperature is changed under the facility water temp.25 deg C.

8.1.2 Cooling capacity

■ **HRZC002/004/008/010-WS**

Fluid: Fluorinated Fluid
 Flow rate: Rated flow
 Facility water temp.: 25deg.C

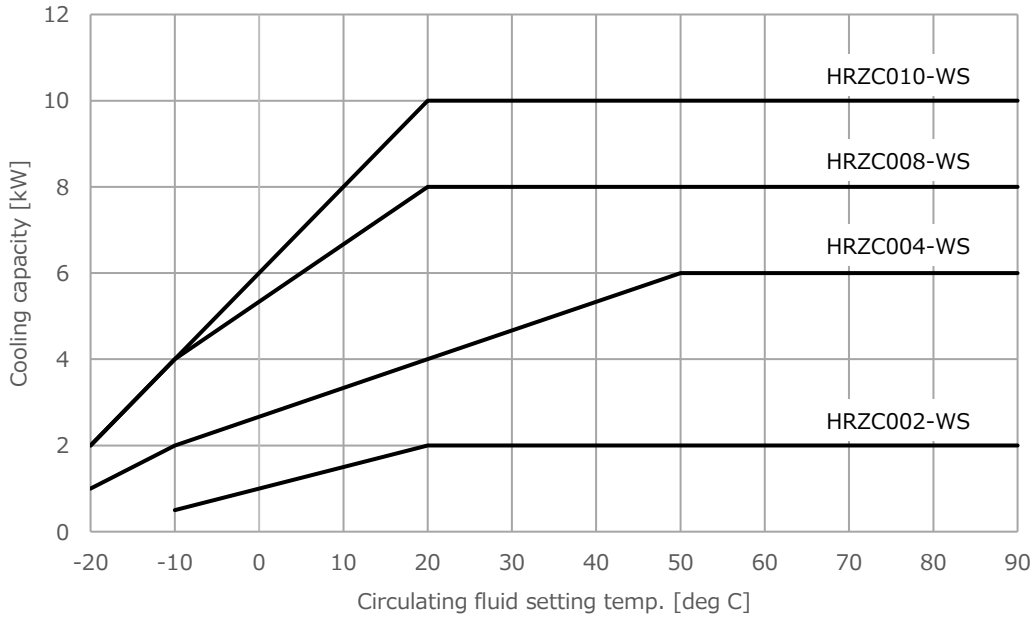

Figure 8-1 Cooling capacity (HRZC002/004/008/010-WS)
 *Common to 50/60Hz

■ **HRZC002/004/008/010-W1S**

Fluid: Ethylene glycol solution 60%
 Flow rate: Rated flow
 Facility water temp.: 25deg.C

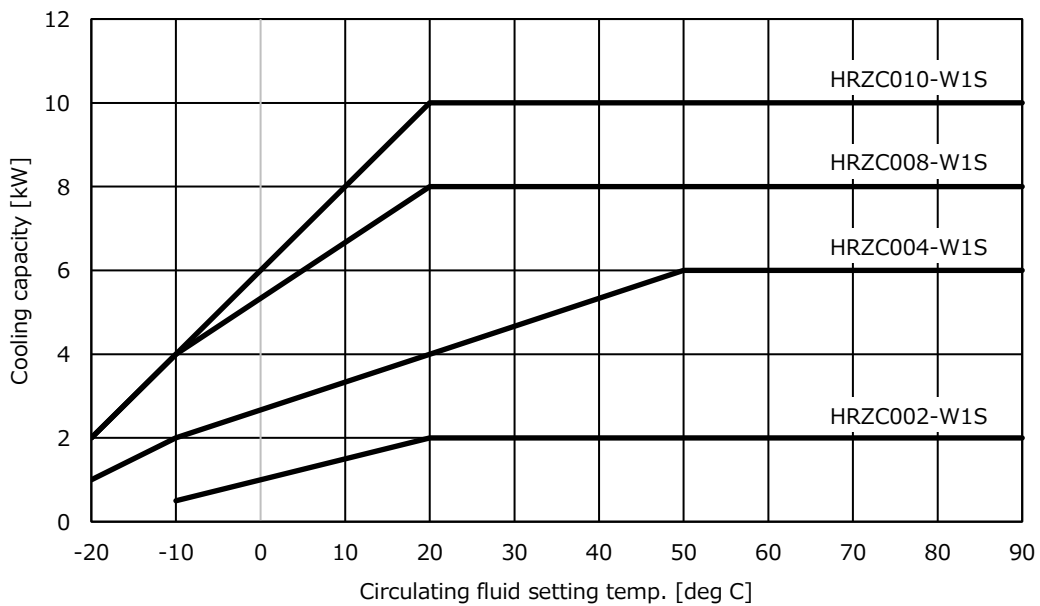

Figure 8-2 Cooling capacity (HRZC002/004/008/010-W1S)
 *Common to 50/60Hz

■ HRZC002/004/008/010-W2S

Fluid: Water
 Flow rate: Rated flow
 Facility water temp.: 25deg.C

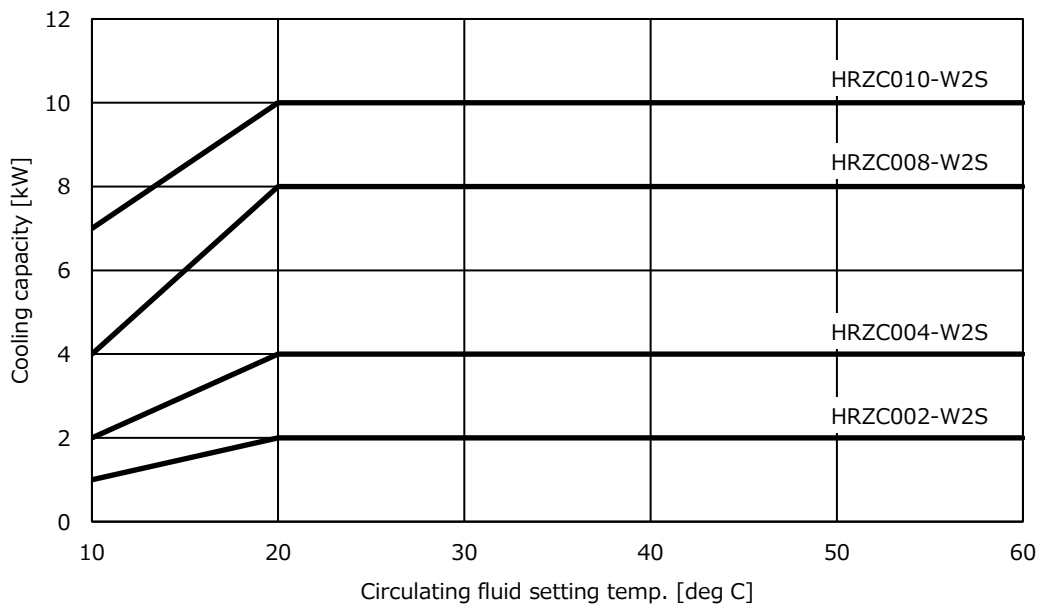

Figure 8-3 Cooling capacity (HRZC002/004/008/010-W2S)
 *Common to 50/60Hz

8.1.3 Heating capacity

■ **HRZC002/004/008/010-WS**

Circulating Fluid: Fluorinated Fluid
 Flow rate: Rated flow

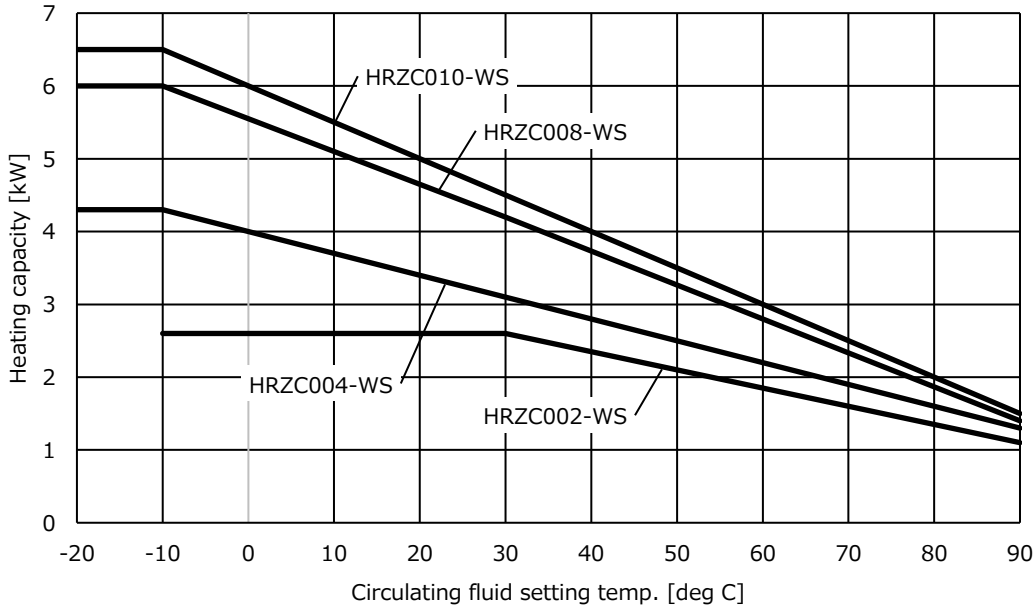

Fig. 8-4 Heating capacity (HRZC002/004/008/010-WS)
 *When pump inverter is operating at frequency of 60Hz (maximum).

■ **HRZC002/004/008/010-W1S**

Fluid: Ethylene glycol solution 60%
 Flow rate: Rated flow

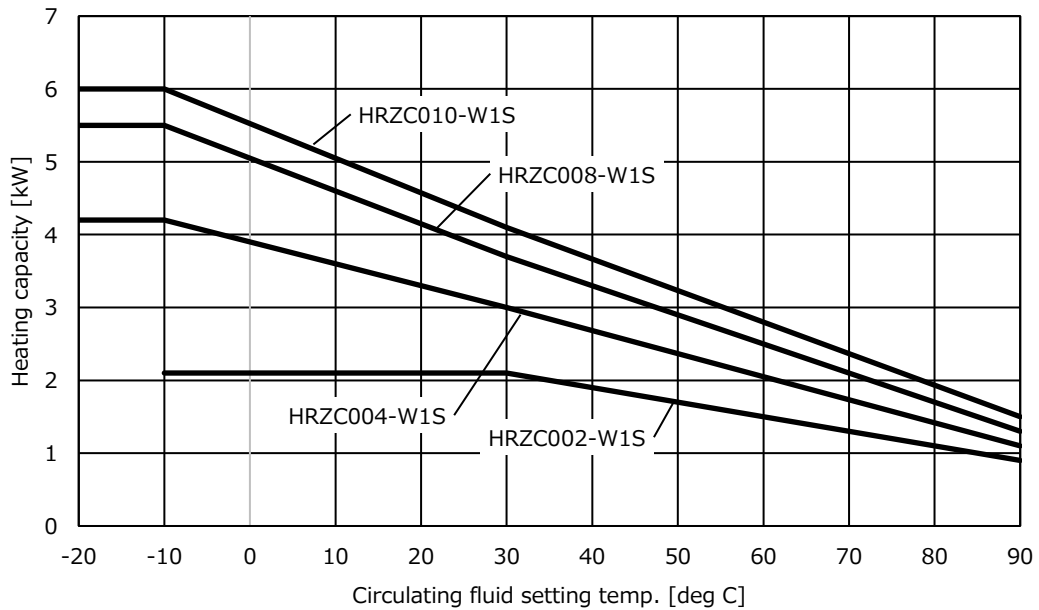

Fig. 8-5 Heating capacity (HRZC002/004/008/010-W1S)
 *When pump inverter is operating at frequency of 60Hz (maximum).

■ HRZC002/004/008/010-W2S

Fluid: Water
Flow rate: Rated flow

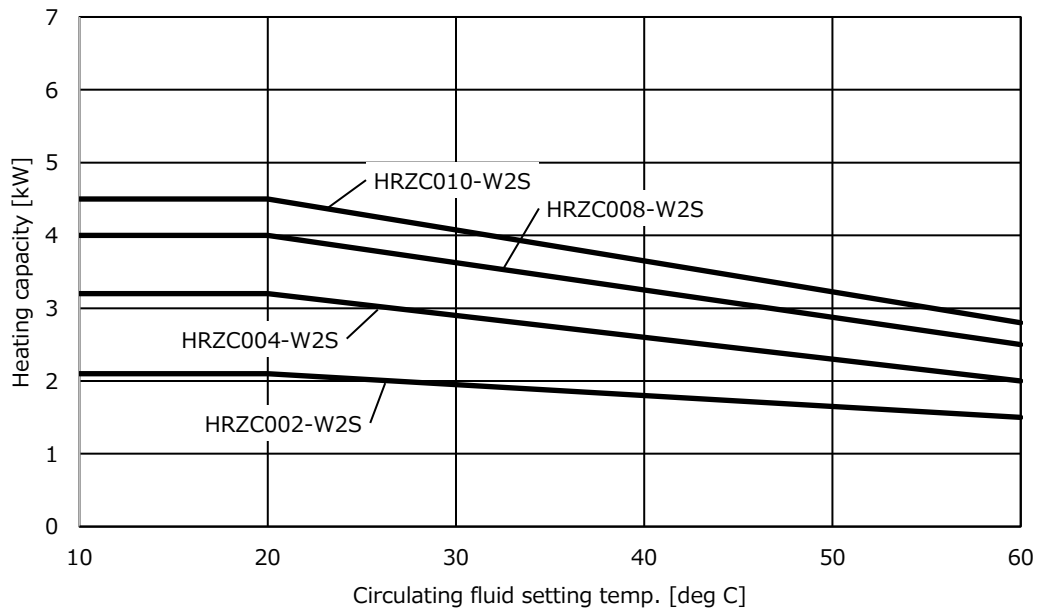

Fig. 8-6 Heating capacity (HRZC002/004/008/010-W2S)
*When pump inverter is operating at frequency of 60Hz (maximum).

8.1.4 Pump Performance Curve

■ HRZC002/004/008/010-WS

Circulating Fluid: Fluorinated Fluid
Operating Temperature: 20 deg.C
At maximum frequency operation by inverter

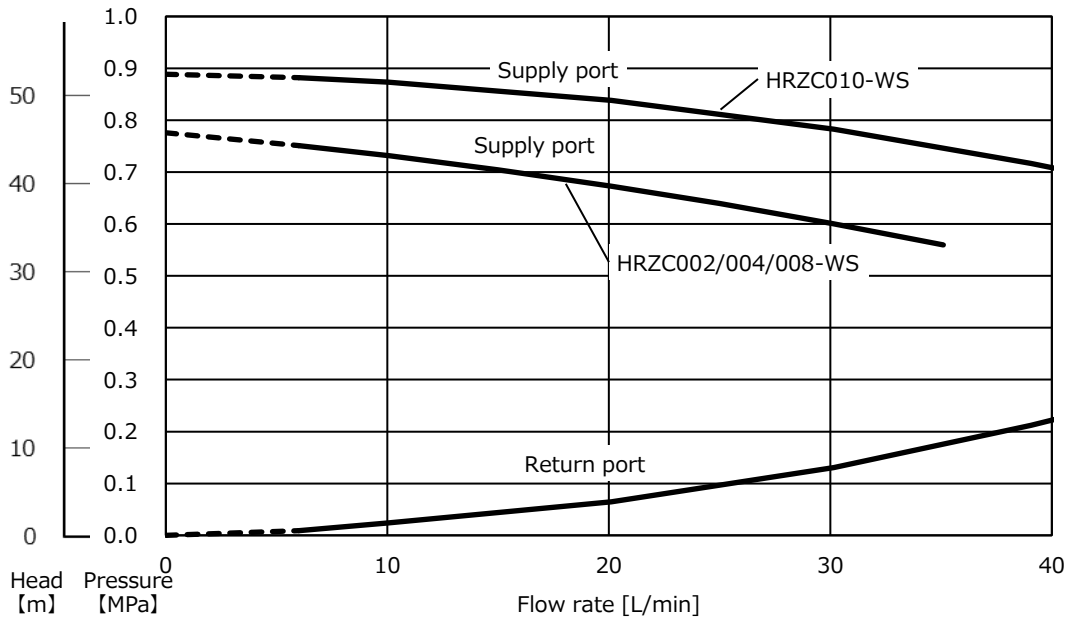

Figure 8-7 Pump Performance Curve (HRZC002/004/008/010-WS)
When circulating fluid flow rate is below 6L/min, an alarm will occur and operation cannot be performed.

■ HRZC002/004/008/010-W1S

Circulating Fluid: Ethylene glycol solution 60%
Operating Temperature: 20 deg.C
At maximum frequency operation by inverter

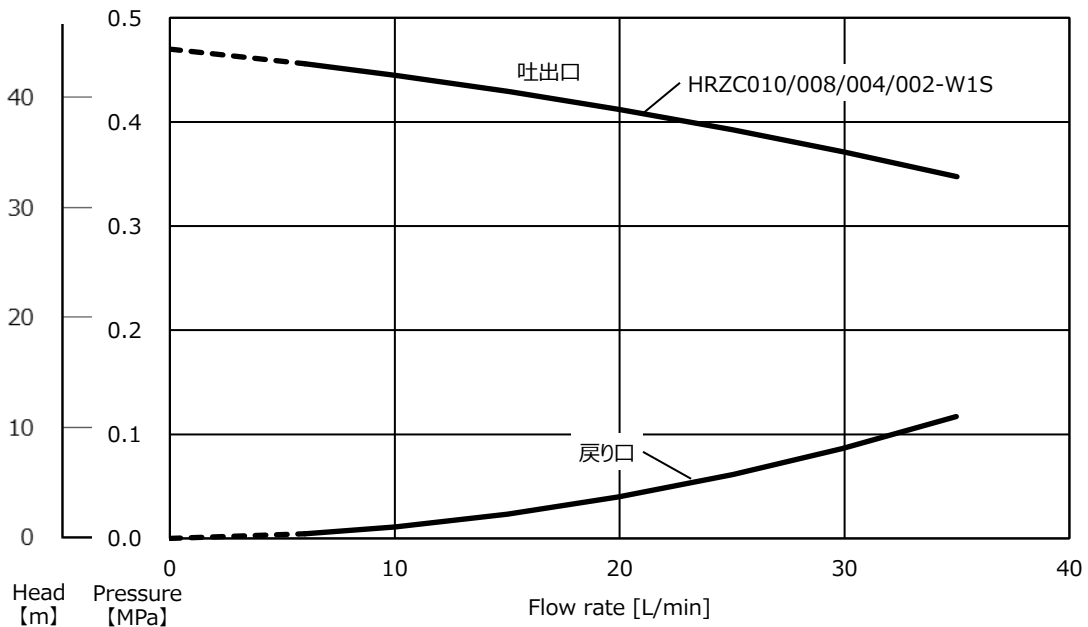

Figure 8-8 Pump Performance Curve (HRZC002/004/008/010-W1S)
When circulating fluid flow rate is below 6L/min, an alarm will occur and operation cannot be performed.

■ HRZC002/004/008/010-W2S

Circulating Fluid: Water
 Operating Temperature: 20 deg.C
 At maximum frequency operation by inverter

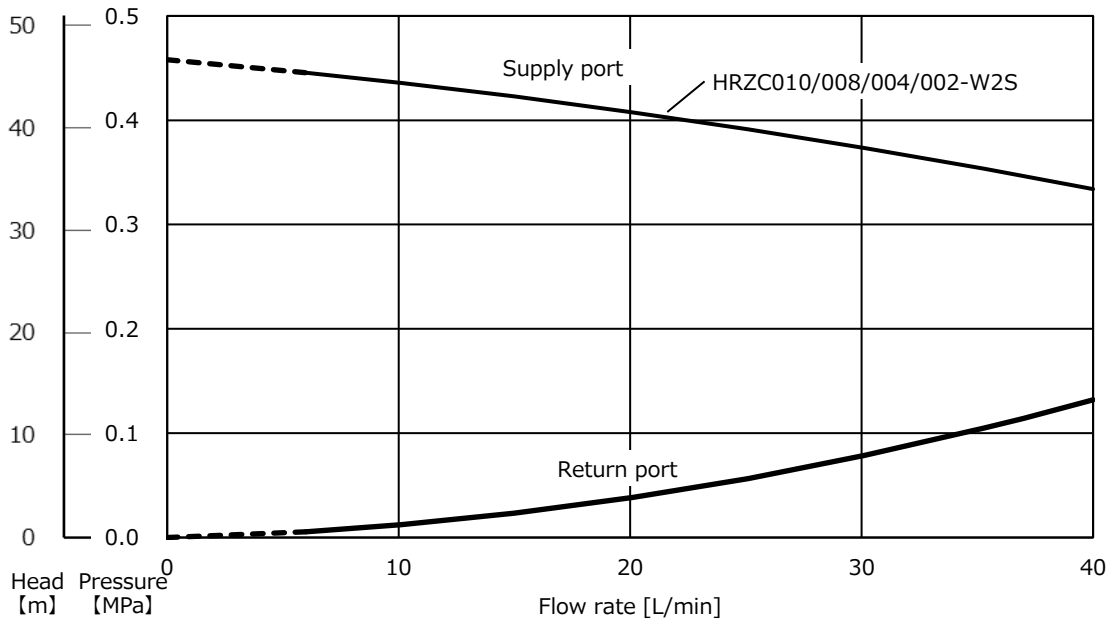

Figure 8-9 Pump Performance Curve (HRZC002/004/008/010-W2S)
 When circulating fluid flow rate is below 6L/min, an alarm will occur and operation cannot be performed.

8.1.5 Communication specification

This section provides the general outline of communications utilized in this product. For detail specification, we provide a separate system manual “Communication Specification”, which is available through your local distributor.

■ Contact signal

Table 8-4 Contact Signal

Item	Specification	
Connector No.	P1	
Connector type (this product)	D-sub25P female connector (M2.6x0.45)	
Input signal	Insulation type	Photocoupler
	Rated input voltage	DC24V
	Used voltage range	DC 21.6V to 26.4V
	Rated input current	5mA TYP
	Input impedance	4.7kΩ
Contact output signal (Other than Pin No. 5-18)	Rated load voltage	Max. AC48V / Max. DC30V
	Max. load current	Max. AC/DC 800mA (Pin No. 15 is common to output signals. Total used load current should be at or below 800mA)
Contact output signal (Pin No. 5-18)	Rated load voltage	Max. AC48V / Max. DC30V
	Max. load current	AC/DC 800mA (resistance load)
Contact output signal (EMO signal)	Rated load voltage	Max. AC48V / Max. DC30V
	Max. load current	AC/DC 800mA (resistance load, inductive load)
Analog input signal*2	Input voltage range	-10 to +10V
	Input impedance	1MΩ
	Input accuracy	+/- 0.2% F.S. or less
Analog output signal*2	Output voltage range	-10 to +10V
	Max. output current	10mA
	Output accuracy	+/- 0.2% F.S. or less

Circuit block diagram

Pin No.	I/O	ITEM	
		Standard specification	CUSTOM DIO
1	Output	DC+24V output	DC+24V output
2	Input	Input signal COM	Input signal COM
14	Output	24COM	24COM
3	Input	Run/Stop signal	Run/Stop signal 1
16	Input	-	Run/Stop signal 2
4	Input	AUTO PURGE signal ¹	DIO REMOTE signal 1 AUTO PURGE signal ¹
17	Input	-	DIO REMOTE signal 2
6	Output	Run status signal	OUT1
19	Output	Warning signal	OUT2
7	Output	Fault signal	OUT3
20	Output	Remote signal	OUT4
8	Output	TEMP READY signal AUTO PURGE status signal	OUT5
15	Input	Output signal COM	Output signal COM
5	Output	-	-
18	Output	Alarm signal	OUT6
11	Output	Temp.PV Analog Output ²	Temp.PV Analog Output ²
23	Output	[-100 to 100deg C:-10 to 10V]	[-100 to 100deg C:-10 to 10V]
10	Output	DI PV Analog Output ³	DI PV Analog Output ³
22	Output	[0 to 20 MΩ:0 to 10V]	[0 to 20 MΩ:0 to 10V]
12	Input	Temp.SP Analog Input ³	Temp.SP Analog Input ³
24	Input	[-100 to 100 deg C:-10 to 10V]	[-100 to 100 deg C:-10 to 10V]
13	Output	EMO signal	EMO signal
25	Output	-	-

*1: The recovery signal can be input only when the circulating fluid automatic recovery function (optional) is used, and it does not serve as the DIO REMOTE signal.
 *2: Valid if Analog Communication (optional) is provided.
 *3: Valid if DI Control Kit (optional) is provided.

■ Serial RS-485

Table 8-5 Serial RS-485

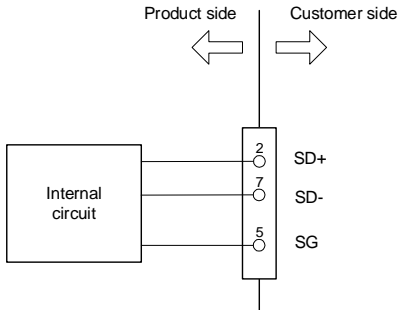
Item	Specification
Connector No.	P2
Connector type (this product)	D-sub9P female connector
Standard	EIA RS485
Protocol	Modicon Modbus
Circuit block diagram	 <p>The diagram shows an 'Internal circuit' block connected to a vertical P2 connector. The connector has three pins: pin 2 labeled 'SD+', pin 7 labeled 'SD-', and pin 5 labeled 'SG'. Above the connector, two arrows point in opposite directions: one pointing left labeled 'Product side' and one pointing right labeled 'Customer side', indicating bidirectional communication.</p>

8.1.6 Alarm signal selection

User can designate one alarm signal for contact signal. See section 5.3.22 Initial Setting screen 7 “page 5-24” for signal selecting.

The following table provides the setting-alarm relationship. The alarm signal is turned OFF if the designated alarm detected (Alarm signal is ON if no alarm is detected).

Table 8-6 Alarm signal selection

Setting	Alarm	Alarm No.
N/A	Alarm signal remains ON (closed) under normal circumstances	-
ALARM01	Water Leak Detect FLT	01
ALARM03	RFGT High Press FLT	03
ALARM04	CPRSR Overheat FLT	04
ALARM05	Reservoir Low Level FLT	05
ALARM06	Reservoir Low Level WRN	06
ALARM07	Reservoir High Level WRN	07
ALARM08	Temp. Fuse Cutout FLT	08
ALARM09	Reservoir High Temp. FLT	09
ALARM10	Return High Temp. WRN	10
ALARM11	Reservoir High Temp. WRN	11
ALARM12	Return Low Flow FLT	12
ALARM13	Return Low Flow WRN	13
ALARM14	Heater Breaker Trip FLT	14
ALARM15	Pump Breaker Trip FLT	15
ALARM16	CPRSR Breaker Trip FLT	16
ALARM19	FAN Motor Stop WRN	19
ALARM20	Internal Pump Time Out WRN	20
ALARM21	Controller Error FLT	21
ALARM22	Memory Data Error FLT	22
ALARM23	Communication Error	23
ALARM24*1	DI Low Level WRN	24
ALARM25	Pump Inverter Error FLT	25
ALARM27	F. Water High Temp. FLT	27
ALARM28	CPRSR Inverter Error FLT	28
ALARM29	RFGT Low Press FLT	29
ALARM30	F. Water High Temp. WRN	30
ALARM32	Reservoir Low Temp. WRN	32

*1: Alarm 24 is alarm assigned to accessories (optional).

- Example

With parameter “OUT” on the Initial Setting screen set to “Alarm1”, alarm “Water Leak Detect FLT” is detected, the alarm contact signal is switched to OFF (open).

8.2 Outer Dimensions

Unit: mm

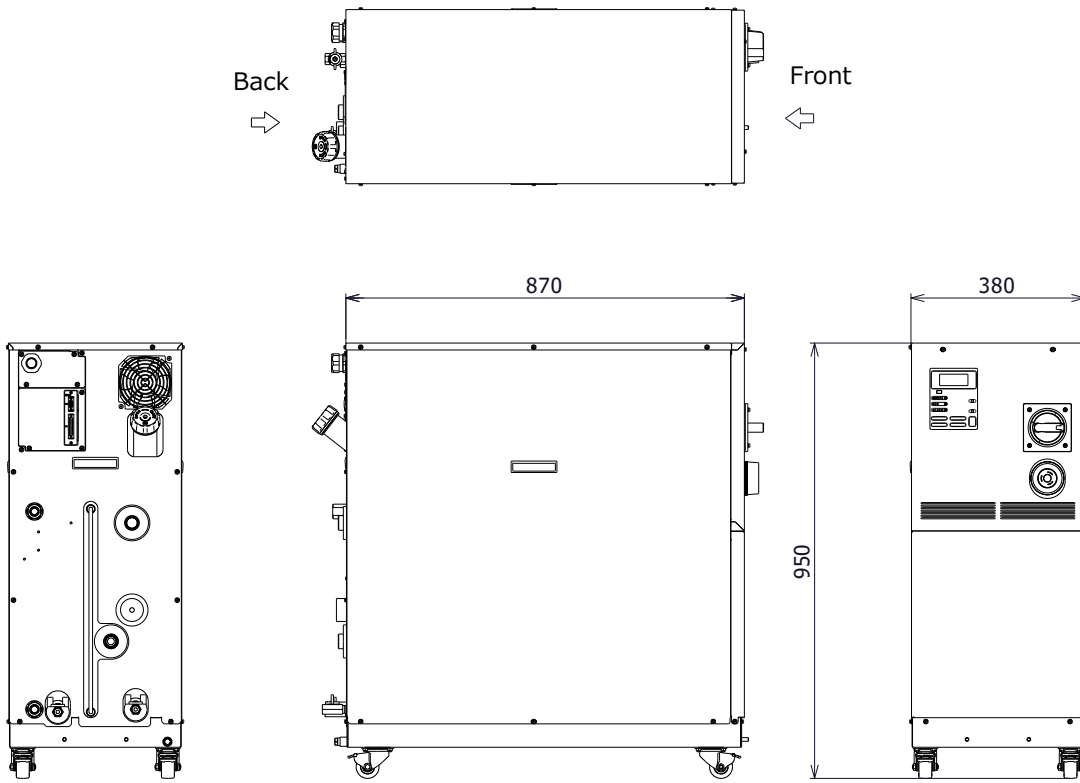

Figure 8-10 Outer Dimensions

8.3 Flow Chart

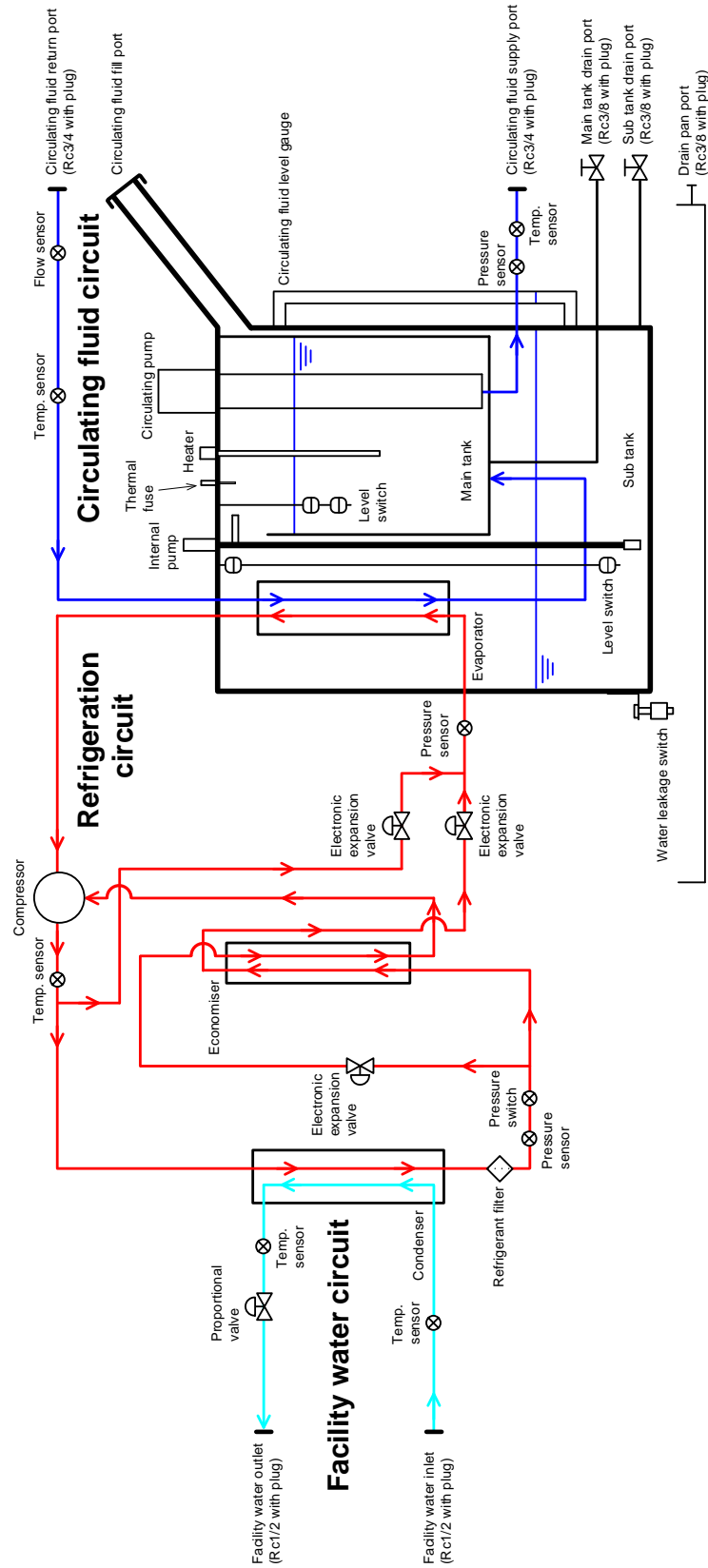

Figure 8-11 Flow Chart

8.4 Offset Function

Potential deviations in temperature between this product and customer system may be of concern depending on the installation environment. The offset function falls into three types (MODE1 to 3), which are assigned to calibrate deviations in temperature.

See the following descriptions for the offset function. See section 5.3.16 "Initial Setting screen 1"(page5-18), for setting.

TEMP PV value, which is displayed on the Status screen, is output as circulating fluid temperature data in terms of communication.

- **When MODE1 is selected**

This mode is used to exercise temperature control to allow the supply temperature of the circulating fluid to be "TEMP SP value + OFFSET value".

TEMP PV value denotes the supply temperature of the circulating fluid.

E.g.: TEMP SP value: +20 deg C, OFFSET value: +2 deg C

→ Circulating fluid supply temp.: +22 deg C, TEMP PV: +22 deg C

- **When MODE2 is selected**

This mode is used to exercise temperature control to allow the supply temperature of the circulating fluid to be "TEMP SP value".

TEMP PV value denotes "Circulating fluid supply temp. value + OFFSET value".

E.g.: TEMP SP value: +20 deg C, OFFSET value: +2 deg C

→ Circulating fluid supply temp.: +20 deg C, TEMP PV: +22 deg C

- **When MODE3 is selected**

This mode is used to exercise temperature control to allow the supply temperature of the circulating fluid to be "TEMP SP value + OFFSET value".

TEMP PV value denotes "Circulating fluid supply temp. value - OFFSET value".

E.g.: TEMP SP value: +20 deg C, OFFSET value: +2 deg C

→ Circulating fluid supply temp.: +20 deg C, TEMP PV: +20 deg C

- **When OFF is selected**

If no mode is selected, temperature control is conducted to allow the supply temperature of the circulating fluid to be "TEMP SP value".

8.4.1 Example of offset function

When the supply temperature of the circulating fluid is at 30deg C, heat is dissipated by 1deg C to allow the circulating fluid in customer system to be 29deg C. Under the above condition, the following process is to be performed with the utilization of MODEs 1 to 3.

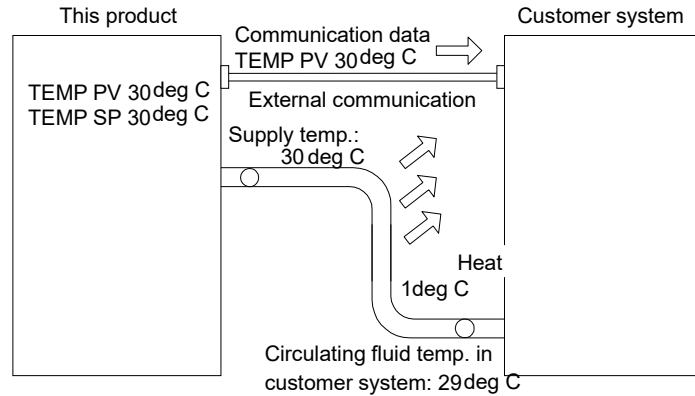

Figure 8-12 Example of Offset Function

■ When MODE1 is selected

This mode enables this product to exercise temperature control to obtain 31deg C (TEMP SP value +OFFSET value), with OFFSET value set at 1deg C. Once the supply temperature of the circulating fluid becomes 31deg C, 1deg C-thermal dissipation is assured to allow the circulating fluid in customer system to be 30deg C. TEMP SP value is obtained for customer system. Note that "31deg C" is recorded in TEMP PV and communication data.

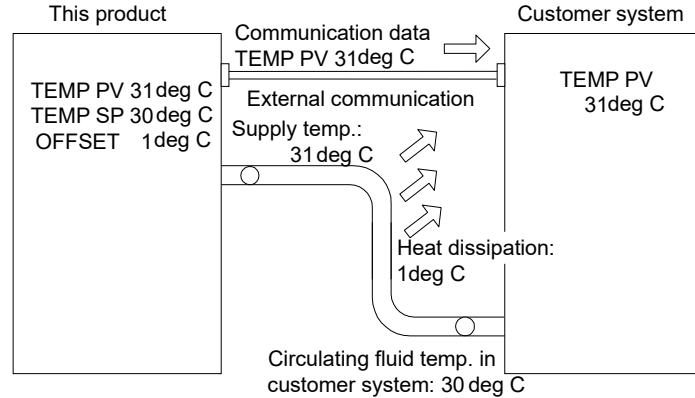

Figure 8-13 When MODE1 is selected

■ **When MODE2 is selected**

With OFFSET value set at -1deg C, TEMP PV and communication data express “29deg C” (circulating fluid supply temp. value + OFFSET value) that agrees with the temperature of the circulating fluid in customer system.

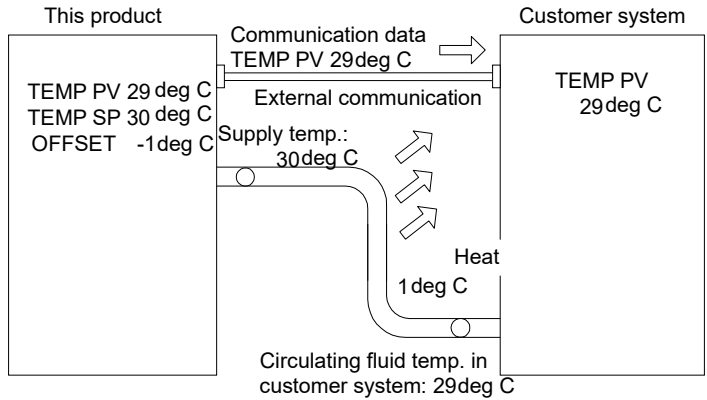

Figure 8-14 When MODE2 is selected

■ **When MODE3 is selected**

This mode enables this product to exercise temperature control to obtain 31deg C (TEMP SP value +OFFSET value), with OFFSET value set at 1deg C. Once the supply temperature of the circulating fluid becomes 31deg C, 1deg C-thermal dissipation is assured to allow the circulating fluid in customer system to be 30deg C. TEMP SP value is obtained for customer system. TEMP PV and communication data also express “30deg C” (circulating fluid supply temp. value - OFFSET value) that agrees with the temperature of the circulating fluid in customer system.

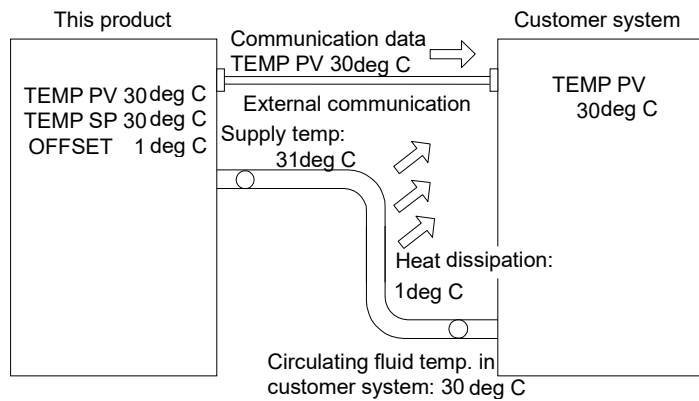

Figure 8-15 When MODE3 is selected

8.5 BAND/READY function

Set BAND to TEMP SP value and it notifies TEMP PV value when it reaches within BAND range by the operation display panel or the communication.

See section “Chapter 5 System Operation 5.3.21 Initial Setting screen 6” on page 5-23, for the procedure of the setting.

- **When the setting is ON**

This allows the setting of the BAND, READY TIME, and communication output.

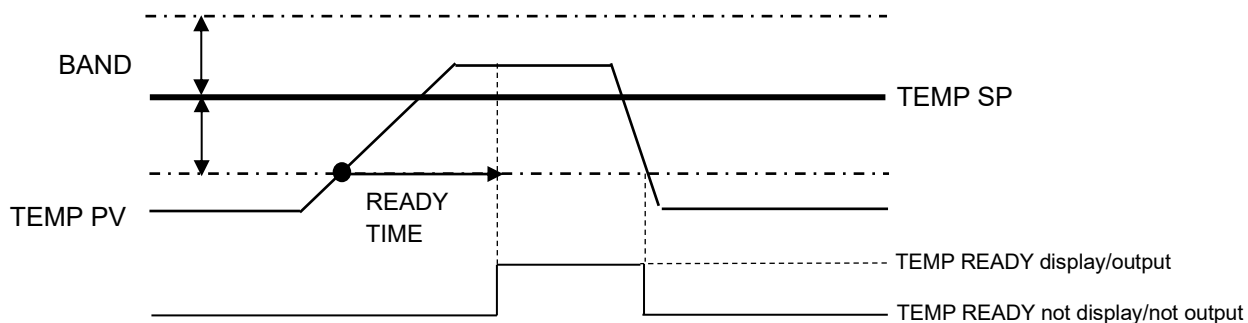

Figure 8-16 BAND/READY function

- **Examples of Setting**

TEMP SP : 20deg C

BAND : 2deg C

READY TIME : 60sec.

“TEMP READY” is displayed on the operation display panel 60-sec. after TEMP PV value becomes 18 deg C to start output by communication.

The necessary condition is that TEMP PV value after 60-sec. is 20+/-2.0 deg C or less. See “5.3.4 Status screen 3” on page 5-7 for the details of display position.

- **When the setting is OFF**

BAND/READY function becomes invalid.

8.6 Anchor Bolt Mounting Position

Lock the brakes on casters and attach the anti-quake bracket (optional: HRZ-TK002) to secure this product.

⚠ CAUTION

! Anti-quake bracket is an optional accessory, which is required for the installation of this product (HRZ-TK002). It is your responsibility to prepare anchor bolts suitable for your floor material. **M12-anchor bolts (4 pcs.) are required.**

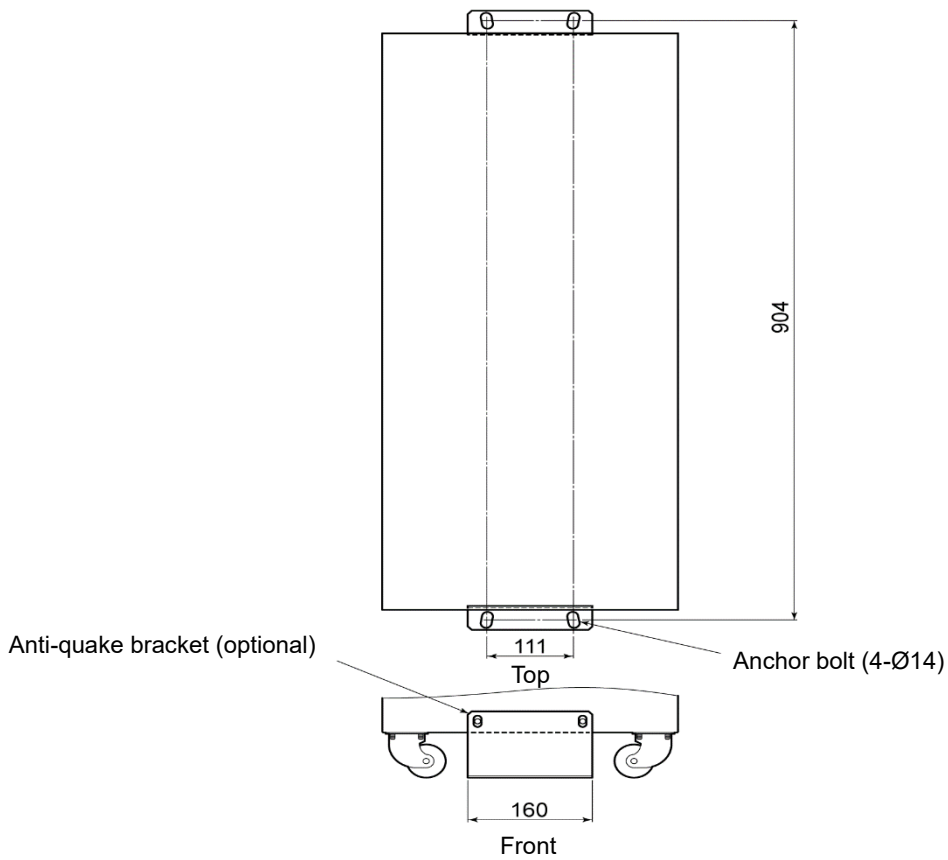

Unit: mm

Figure 8-17 Anchor Bolt Mounting Position

8.7 Compliance

This product conforms to the following standards.

Table 8-7 Compliance

CE Marking	EMC Directive	2014/30/EU
	Machinery Directive	2006/42/EC
	RoHS Directive	2011/65/EU
SEMI	S2, S8, F47	
UL	UL60335-2-40	

SMC® 8.8 Thermo Chiller Daily Inspection Sheet

Model: _____
Serial No. _____

To confirm daily inspection item on the Thermo Chiller, See "Table 7-2 Daily Inspection" in "7.2.1 Daily inspection" of "Chapter 7.

Your name	Date	Installation		Leakage		Fluid Level	Operation display panel		Circulating fluid temp.	Refrigerant press.	Circulating fluid outlet press.	Circulating fluid flowrate	Operating condition	Facility water			Circulating fluid supply part cap	Judgment	
		Temp.	Humidity	Evacuating fluid	Cooling water		Display	Function						Temp.	Flowrate	IN press.			Looseness
After installation (initial value)		°C	%	Yes/No	Yes/No	IN/OUT of range	Display	Function	°C	MPa	MPa	L/min	Yes/No	Temp.	Flowrate	IN press.	Looseness	Yes/No	

Chapter 9 Limited warranty and Disclaimer/ Compliance Requirements

The product used is subject to the following “Limited warranty and Disclaimer” and “Compliance Requirements”. Read and accept them before using the product.

1. Period

The warranty period of the product is 1 year in service or 1.5 years after the product is delivered, whichever is first.

2. Scope

For any failure reported within the warranty period which is clearly our responsibility, replacement parts will be provided. In that case, removed parts shall become the property of SMC.

This guarantee applies only to our product independently, and not to any other damage incurred due to the failure of the product.

3. Content

1. We guarantee that the product will operate normally if it is installed under maintenance and control in accordance with the Operation Manual, and operated under the conditions specified in the catalog or contracted separately.
2. We guarantee that the product does not have any defects in components, materials or assembly.
3. We guarantee that the product complies with the outline dimensions provided.
4. The following situations are out of scope of this warranty.
 - (1) The product was incorrectly installed or connected with other equipment.
 - (2) The product was under insufficient maintenance and control or incorrectly handled.
 - (3) The product was operated outside of the specifications.
 - (4) The product was modified or altered in construction.
 - (5) The failure was a secondary failure of the product caused by the failure of equipment connected to the product.
 - (6) The failure was caused by a natural disaster such as an earthquake, typhoon, or flood, or by an accident or fire.
 - (7) The failure was caused by operation different from that shown in the Operation Manual or outside of the specifications.
 - (8) The checks and maintenance specified (daily checks and regular checks) were not performed.
 - (9) The failure was caused by the use of circulating fluid or facility water other than those specified.
 - (10) The failure occurred naturally over time (such as discoloration of a painted or plated face).
 - (11) The failure does not affect the functioning of the product (such as new sounds, noises and vibrations).
 - (12) The failure was due to the “Installation Environment” specified in the Operation Manual.
 - (13) The failure was caused by the customer disregarding “6. Request to customers”.

4. Agreement

If there is any doubt about anything specified in “2. Scope” and “3. Content”, it shall be resolved by agreement between the customer and SMC.

5. Disclaimer

- (1) Expenses for daily and regular checks
- (2) Expenses for repairs performed by other companies
- (3) Expenses for transfer, installation and removal of the product
- (4) Expenses for replacement of parts other than those in this product, or for the supply of liquids
- (5) Inconvenience and loss due to product failure (such as telephone bills, compensation for workplace closure, and commercial losses)
- (6) Expenses and compensation not covered in “2. Scope”.

6. Request to customers

Proper use and maintenance are essential to assure safe use of this product. Be sure to satisfy the following preconditions. Please note that we may refuse to carry out warranted repair if these preconditions have been disregarded.

- (1) Use the product following the instructions for handling described in the Operation Manual.
- (2) Perform checks and maintenance (daily checks and regular checks) specified in the Operation Manual and Maintenance Manual.
- (3) Record the check and maintenance results on the daily check sheet attached to the Operation Manual and Maintenance Manual.

7. Request for Warranted Repair

For warranted repair, please contact the supplier you purchased this product from.

Warranted repair shall be on a request basis.

Repair shall be provided free of charge in accordance with the warranty period, preconditions and terms defined above. Therefore, a fee will be charged for any repairs if a failure is detected after the end of the warranty period.

Revision history
Rev.2: Mar. 2025

SMC Corporation

Tel: + 81 3 5207 8249 Fax: +81 3 5298 5362

URL <https://www.smcworld.com>

Note: Specifications are subject to change without prior notice and any obligation on the part of the manufacturer.
© SMC Corporation All Rights Reserved