



Operation Manual

Original Instructions

Thermo-Chiller

- HRZ002-WS-F* *HRZ002-W1S-F* *HRZ002-W2S-F*
- HRZ004-WS-F* *HRZ004-W1S-F* *HRZ004-W2S-F*
- HRZ008-WS-F* *HRZ008-W1S-F* *HRZ008-W2S-F*
- HRZ008-L-F* *HRZ008-L1-F*
- HRZ010-WS-F* *HRZ010-W1S-F* *HRZ010-W2S-F*

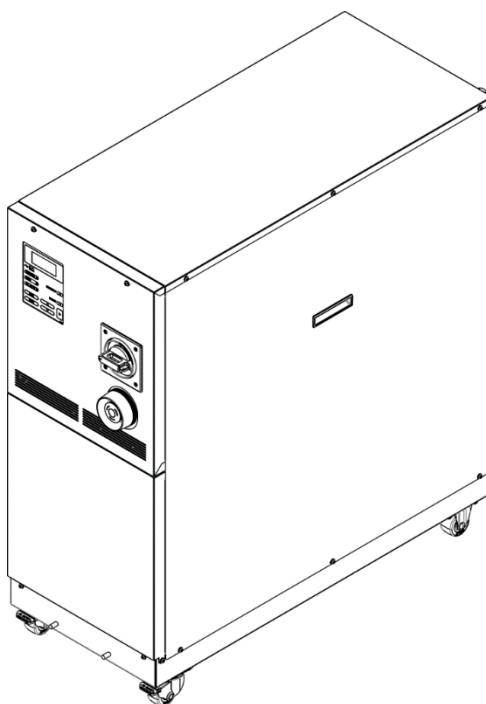

Save This Manual Carefully for Use at Any Time

To the Customers

Thank you for purchasing our THERMO CHILLER HRZ Series (hereinafter called “This system”).

For the long-term, safe use of this system, be sure to read and understand this manual thoroughly before performing operation of this system.

- Warnings and precautions defined in this manual shall be observed.
- This manual provides the explanations of the installation and operation of this system. Only those who have thorough understanding of the fundamental operating procedure or have basic knowledge and skills of handling industrial equipment for the installation and operation of this system are qualified to perform installation and operation.
- The contents of this manual and related documents supplied with this system shall be neither regarded as a provision of the contract nor utilized to correct or modify the existing agreements, commitments and relations.
- Copying, duplicating or transferring any part of or whole contents of this manual without the prior written consent of SMC Corporation is strictly prohibited.
- The Service Manual is supplied in addition to this manual and provides the explanations of the inspection, troubleshooting, and in-depth remedies of this system. The Service Manual is intended for service personnel that completed service training SMC provides. Only those who fall under the above condition are allowed to perform maintenance and repair of this system with the use of the Service Manual.

Note: The contents of this manual are subject to change without

Table of Contents

Chapter 1 Safety	1-1
1.1 Before Using this System	1-1
1.2 Danger, Warning, and Caution Used in This Manual	1-2
1.2.1 Hazard Levels	1-2
1.2.2 Definitions of “Serious injury” and “Minor injury”	1-2
1.2.3 Symbols.....	1-3
1.3 Hazard Warning Label	1-4
1.3.1 Type of hazard warning label	1-4
1.3.2 Location of hazard warning label	1-5
1.4 Location of Model Label	1-7
1.5 Safety Measures	1-8
1.5.1 Safety Precautions	1-8
1.5.2 Safety Interlock system	1-9
1.5.3 Lockout/Tagout	1-10
1.5.4 Protective equipment.....	1-12
1.6 Emergency Measures	1-13
1.6.1 Emergency off [EMO] switch	1-13
1.7 Waste Disposal	1-15
1.7.1 Disposal of refrigerant and compressor oil.....	1-15
1.7.2 Circulating fluid disposal.....	1-16
1.7.3 System disposal	1-16
1.7.4 Label.....	1-16
1.8 Material Safety Data Sheet (SDS)	1-16
1.8.1 Galden® HT135	1-17
1.8.2 Fluorinert™ FC-3283.....	1-29
1.8.3 Galden® HT200	1-38
1.8.4 Fluorinert™ FC-40.....	1-50
1.8.5 Ethylene glycol aqueous solution 60%.....	1-58
1.8.6 Refrigerant R410A.....	1-64
1.8.7 Refrigerant R448A.....	1-76
Chapter 2 Name of Each Section	2-1
2.1 Name of Each Section (1)	2-1
2.2 Name of Each Section (2)	2-2
Chapter 3 Transporting and Installation	3-1
3.1 Transporting	3-1
3.1.1 Transporting with forklift	3-2
3.1.2 Transporting with caster	3-3

Table of Contents

- 3.2 Installation..... 3-3**
 - 3.2.1 Installation conditions 3-4
 - 3.2.2 Installation location and maintenance work area 3-5
- 3.3 Procedure for Installation..... 3-6**
 - 3.3.1 Installation..... 3-6
 - 3.3.2 Procedure for system securing (1) 3-6
 - 3.3.3 Procedure for system securing (2) 3-7
 - 3.3.4 Wiring installation..... 3-8
 - 3.3.5 Procedures for wiring installation..... 3-11
 - 3.3.6 Installation of circulating fluid and facility water piping 3-15
- Chapter 4 System Startup and Shutdown 4-1**
 - 4.1 Pre-check..... 4-1**
 - 4.1.1 Installation condition 4-1
 - 4.1.2 Cable connection 4-1
 - 4.1.3 Installation of circulating fluid and facility water piping 4-1
 - 4.1.4 Operating signal from your system 4-1
 - 4.1.5 Check emergency off [EMO] switch 4-1
 - 4.2 Opening of Facility water Valve 4-1**
 - 4.3 Supply of Circulating Fluid..... 4-2**
 - 4.3.1 Preparation of circulating fluid 4-2
 - 4.3.2 Supply of circulating fluid 4-3
 - 4.4 Requirement for System Startup 4-4**
 - 4.4.1 Turning ON power..... 4-4
 - 4.4.2 Circulating fluid temperature setting 4-5
 - 4.5 System Startup and Shutdown 4-5**
 - 4.5.1 System startup..... 4-5
 - 4.5.2 System shutdown 4-5
- Chapter 5 System Operation..... 5-1**
 - 5.1 Operation Display Panel..... 5-1**
 - 5.2 Flow Chart of Operation Screen..... 5-2**
 - 5.3 Operation Screen 5-4**
 - 5.3.1 Model Indication screen..... 5-4
 - 5.3.2 Status screen 1 5-5
 - 5.3.3 Status screen 2 5-6
 - 5.3.4 Status screen 3 5-7
 - 5.3.5 Status screen 4 5-8
 - 5.3.6 Alarm Display screen 5-9
 - 5.3.7 Menu screen 5-9
 - 5.3.8 Setting screen 5-10

5.3.9	Control Setting screen 1	5-11
5.3.10	Control Setting screen 2	5-13
5.3.11	Control Setting screen 3-1	5-14
5.3.12	Control Setting screen 3-2	5-15
5.3.13	Alarm Setting screen 1	5-16
5.3.14	Alarm Setting screen 2	5-17
5.3.15	Alarm Setting screen 3	5-18
5.3.16	Initial Setting screen 1	5-19
5.3.17	Initial Setting screen 2	5-20
5.3.18	Initial Setting screen 3	5-21
5.3.19	Initial Setting screen 4	5-22
5.3.20	Initial Setting screen 5	5-23
5.3.21	Initial Setting screen 6	5-24
5.3.22	Initial Setting screen 7	5-25
5.3.23	Initial Setting screen 8	5-26
5.3.24	Mode Selection screen	5-27
5.3.25	Maintenance screen 1	5-28
5.3.26	Maintenance screen 2	5-29
5.3.27	Maintenance screen 3	5-30
5.3.28	Maintenance screen 4	5-31
5.3.29	Maintenance screen 5	5-32
5.3.30	Maintenance screen 6	5-33
5.3.31	Maintenance screen 7	5-34
5.3.32	Maintenance screen 8	5-35
5.3.33	System Information screen	5-36
5.4	Examples of System Operation	5-37
5.4.1	Example 1: Circulating fluid set temperature is changed from 20.0 deg C to 34.1 deg C	5-37
5.4.2	Example 2: Communication mode is switched from "LOCAL" to "SER REMOTE"	5-39
5.4.3	Example 3: PUMP IV is switched from "FLOW" to "FREQ"	5-40
Chapter 6	Error Message and Troubleshooting	6-1
6.1	Error Message	6-1
6.2	Troubleshooting	6-2
Chapter 7	System Maintenance	7-1
7.1	Water Quality Management	7-1
7.2	Inspection and Cleaning	7-2
7.2.1	Daily inspection	7-2
7.2.2	Quarterly inspection	7-3
7.3	Storage	7-3
7.3.1	Draining of circulating fluid out of tank	7-4

Table of Contents

7.3.2 Draining of facility water..... 7-5

7.4 Periodic Replacement Parts..... 7-6

Chapter 8 Appendix..... 8-1

8.1 Specification 8-1

8.1.1 System specification 8-1

8.1.2 Cooling capacity 8-6

8.1.3 Heating capacity 8-9

8.1.4 Pump Performance Curve 8-12

8.1.5 Refrigerant with GWP reference..... 8-15

8.1.6 Communication specification 8-16

8.1.7 Alarm signal selection..... 8-19

8.2 Outer Dimensions 8-20

8.2.1 Part 1 8-20

8.2.2 Part 2 8-20

8.3 Flow Chart..... 8-21

8.3.1 Part 1 8-21

8.3.2 Part 2 8-22

8.4 Offset Function 8-23

8.4.1 Example of offset function 8-24

8.5 BAND/READY function 8-26

8.6 Anchor Bolt Mounting Position 8-27

8.6.1 Part 1 8-27

8.6.2 Part 2 8-28

8.7 Compliance 8-29

8.8 Thermo Chiller Daily Inspection Sheet..... 8-30

Chapter 9 Product Warranty 9-1

Chapter 1 Safety



Be sure to read and understand the important precautions defined in this manual thoroughly prior to system use.

1.1 Before Using this System

- This "Safety" chapter describes the safety-related items that users should be aware of upon handling this system.
- This system, which is operated under high voltage, is outfitted with the parts that cause a rise or drop in temperature and rotating parts when it is in action. All personnel who work with or around this system are required to thoroughly read and understand the safety-related items in this manual prior to working with or around this system.
- This manual is not intended to be used as a manual for comprehensive safety and hygiene education. Such a manual should be provided by a safety training manager.
- The product is operated at high voltage and contains components which become hot and rotate. If a component needs to be replaced or repaired, contact a specialized vendor for parts and service.
- A safety manager is responsible for observing safety standards. Operators and maintainers, however, are to have individual responsibilities for complying with the safety standard in his/her daily work.
- Operators and maintainers must individually take account of safety and assure a proper working area and working environment.
- The relevant personnel must receive proper safety education prior to work training on this system. Otherwise, personnel may be exposed to hazards. Never conduct work training without giving proper consideration to safety.
- Do not use the materials that rust or corrode for the circulating fluid and facility water circuits. Using the materials that tend to rust or corrode may cause clogs or/and leakages of the circulating fluid and facility water circuits. In case of using these kind of materials, consider and carry out some prevention against the rusting or corrosion on the customer side.
- Save this manual at a designated place for reference when necessary.

1.2 Danger, Warning, and Caution Used in This Manual

1.2.1 Hazard Levels

This system is designed with its first priority being the safety of workers and the prevention of system damage. This manual classifies the risks into the following three categories according to the severity and level of the hazard; Danger, Warning, and Caution. Read the statements carefully, thoroughly understand them before operating this system.

DANGER, WARNING and CAUTION signs are in order according to hazard severity (DANGER > WARNING > CAUTION). See below for the details.

DANGER

"DANGER" denotes that there is an imminent hazard which will cause serious personal injury or death during operation.

WARNING

"WARNING" denotes that there is a hazard which may cause serious personal injury or death during operation.

CAUTION

"CAUTION" denotes that there is a hazard which may cause minor personal injury during operation.

CAUTION

"CAUTION" without an exclamation symbol denotes that there is a hazard which may cause damage or failure of this system, facility, or devices.

[Tips]

Tips are provided when there is information personnel are required to be aware of for system operation and maintenance. If the task carries useful information, the relevant tips are given as well.

1.2.2 Definitions of “Serious injury” and “Minor injury”

■ “Serious injury”

This term describes injuries such as loss of eyesight, wound, burns, frostbite, electric shock, fracture, and toxication that leave aftereffects, and/or injury requiring hospitalization and/or prolonged staying in a hospital.

■ “Minor injury”

This term describes injuries that do not require hospitalization or prolonged staying in a hospital (injuries other than “serious injuries” described above).

1.2.3 Symbols

This manual provides the following symbols in addition to “Danger”, “Warning”, and “Caution” to present the warning details in easy-to-understand manner.

■ Symbol of electrical hazard

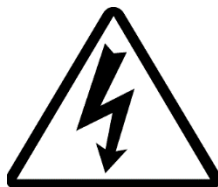

This symbol warns you of potential electrical shock.

■ Symbol of heat hazard



This symbol warns you of potential burns.

■ Symbol of low temperature hazard



This symbol warns you of potential frostbite.

■ Symbol of “Don’ts”



This symbol denotes “Don’t” item which you must not do in operation of this system.

■ Symbol of “Required Action”



This symbol denotes the “obligation” items which you must follow in operation of this system.

1.3 Hazard Warning Label

The hazard warning labels are applied to the sections of this system where potential hazards are present during system operation and maintenance.

The hazard warning labels are in appropriate sizes and colors to get attention of the operator. They contain symbols in addition to the descriptions of warnings.

1.3.1 Type of hazard warning label

The hazard warning labels affixed on this system are listed below.

■ Labels of high voltage hazard

[High voltage hazard]

This warning label is affixed on the part isolated with the cover panel of the system panel in which high voltage is applied.
 Do not remove cover panels that are not designated in this manual.



Figure 1-1 Hazard warning label No. 1



Figure 1-2 Hazard warning label No.2

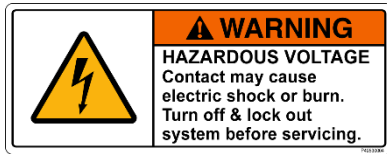

Figure 1-3 Hazard warning label No.3

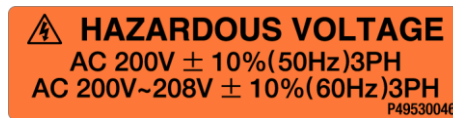

Figure 1-4 Hazard warning label No.4

■ Labels of hot/cold surface hazard

[Hot/cold surface hazard]

This warning label is affixed on the surface that is at high or low temperatures carrying potential burns (or frostbite) if touched. Residual heat may cause burns despite the power being turned OFF. Be sure of the surface reaching room temperature before work.



Figure 1-5 Hazard warning label No.5

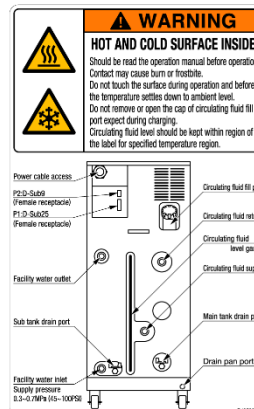



Figure 1-6 Hazard warning label No.6

1.3.2 Location of hazard warning label

⚠ WARNING

 Do not peel off or deface the hazard warning labels.

⚠ WARNING

 • Confirm the locations of the hazard warning labels.
• Read the contents of the hazard warning labels carefully and keep them in mind.

⚠ WARNING

 Users are NOT allowed to change the locations of the hazard warning labels. Make sure to affix a new label to exactly the same location of the replaced label upon replacement of the peeled off or worn out label.

■ High voltage hazard

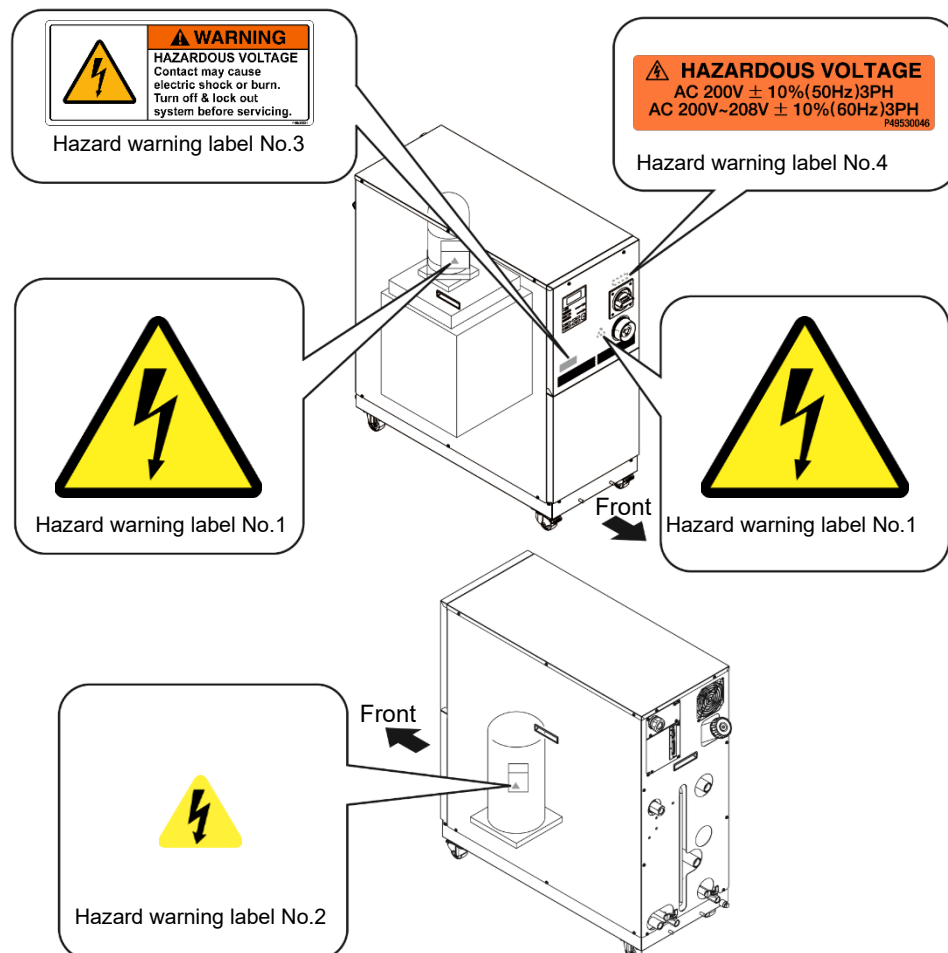

Figure 1-7 High Voltage Hazard

■ Hot/cold surface hazard

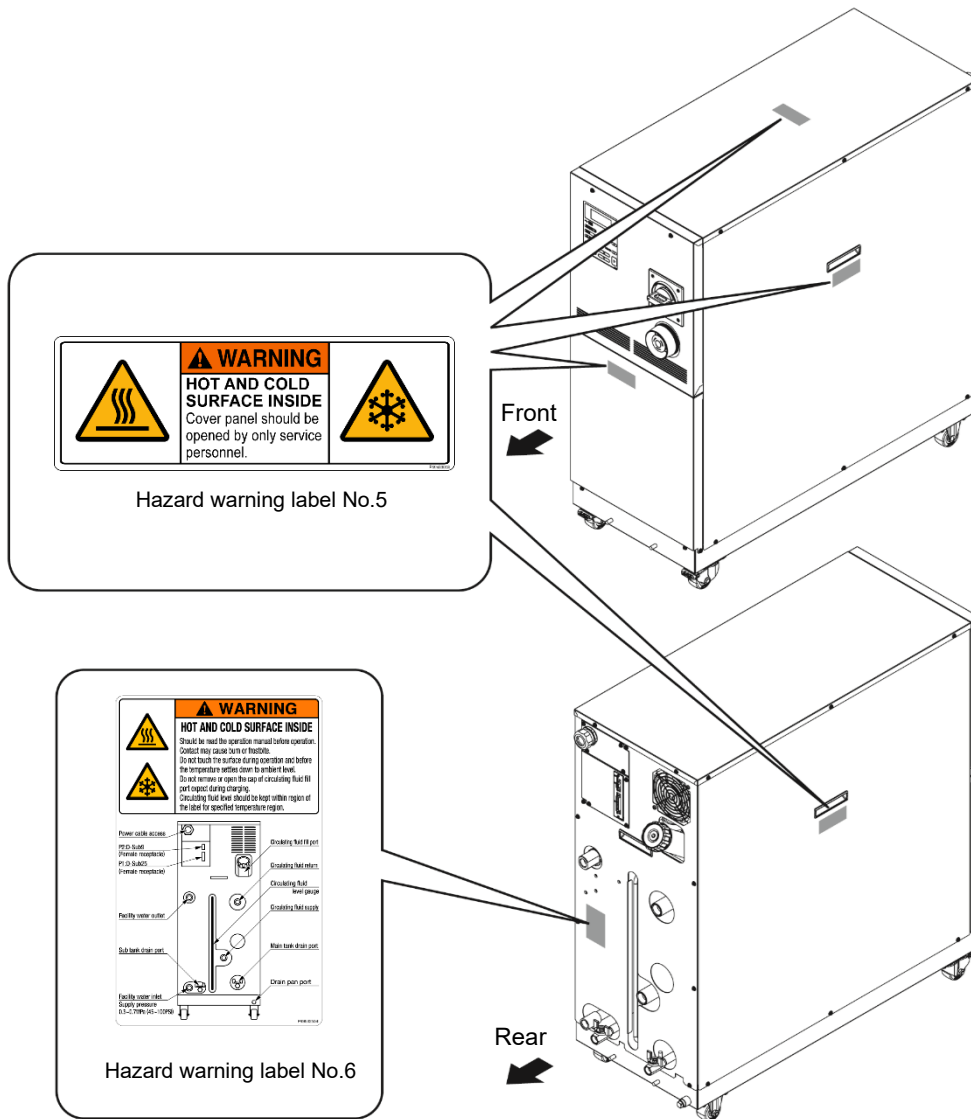

Figure 1-8 Hot/Cold Surface Hazard

1.4 Location of Model Label

Information about the product, such as Serial No. and Model No. can be found on the product label. This information is needed when contacting an SMC sales distributor.

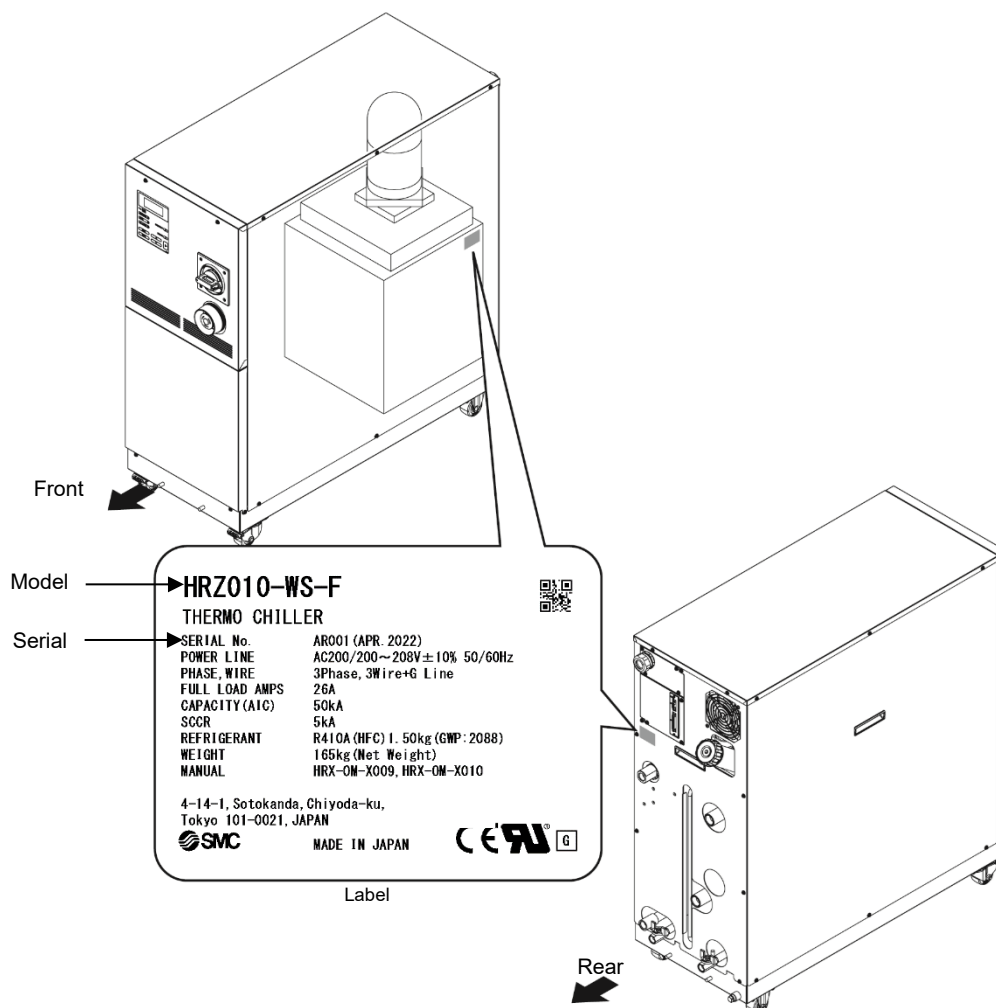

Figure 1-9 Location of Model Label

1.5 Safety Measures

1.5.1 Safety Precautions

While this system is protected by various safety measures including the safety interlocks, the following basic safety precautions should be observed to assure further safe operations.

WARNING



Follow the following instructions upon operation of this system. Failure to follow the instructions can lead to personal injury or hazardous accidents.

- Read and understand this manual thoroughly before operation of this system.
- Before operating the system during maintenance, inform all personnel who are working in the vicinity of the system to alert them of your action.
- Use appropriate tools and follow proper procedures.
- See “1.5.4 Protective equipment” on page 1-12 to wear protective equipment properly.
- Refer to your safety manual for emergency evacuation.
- Use assistance to carry object over 20 kg.
- Check that all parts and screws are returned to the pre-work conditions at the end of work.
- Do not work when intoxicated or feeling ill. Accidents may occur if disregarded.
- Do not remove a panel unless permitted in this manual.
- Do not handle this product by any means other than specified in this Operation Manual.

1.5.2 Safety Interlock system

■ Safety Interlock system

The function of the safety interlock system is not only protect personnel by restricting operation that may cause damage to this system or the facility around it but also eliminate the danger relating to safety. This system is outfitted with several interlock functions that are activated when improper operation or hazardous conditions occur. System operation shall be terminated when a safety interlock is activated.

An alarm message is displayed on the LCD screen when a safety interlock is activated. See “Chapter 6 Error Message and Troubleshooting” on page 6-1 for details on the alarms and remedies or see section “Troubleshooting” in a separate volume of the “Service Manual”.

■ Front panel

System repair may require the removal of the front panel.
The breaker handle operation is available only with the front panel attached.

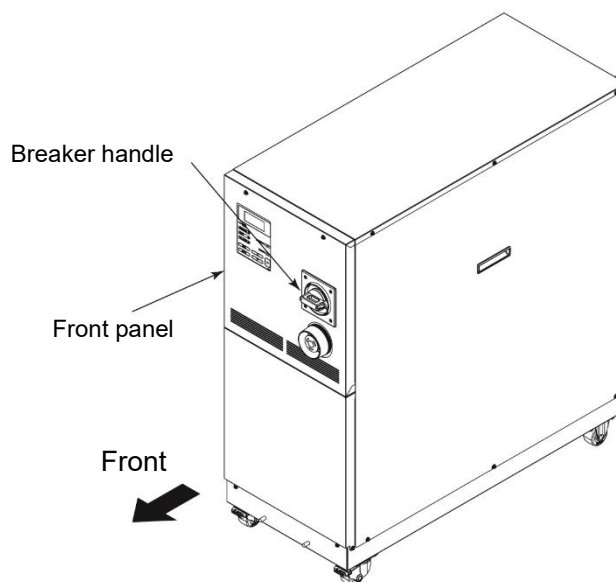

Figure 1-10 Front Panel

1.5.3 Lockout/Tagout

■ Summary

Lockout in this system disables the main breaker operation to prevent electric shocks.
Tagout, to be placed on a locked out main breaker, to prevent improper breaker operation (ON) conducted by other personnel.
See “■ Lockout procedure” in the following pages for practical lockout/tagout.

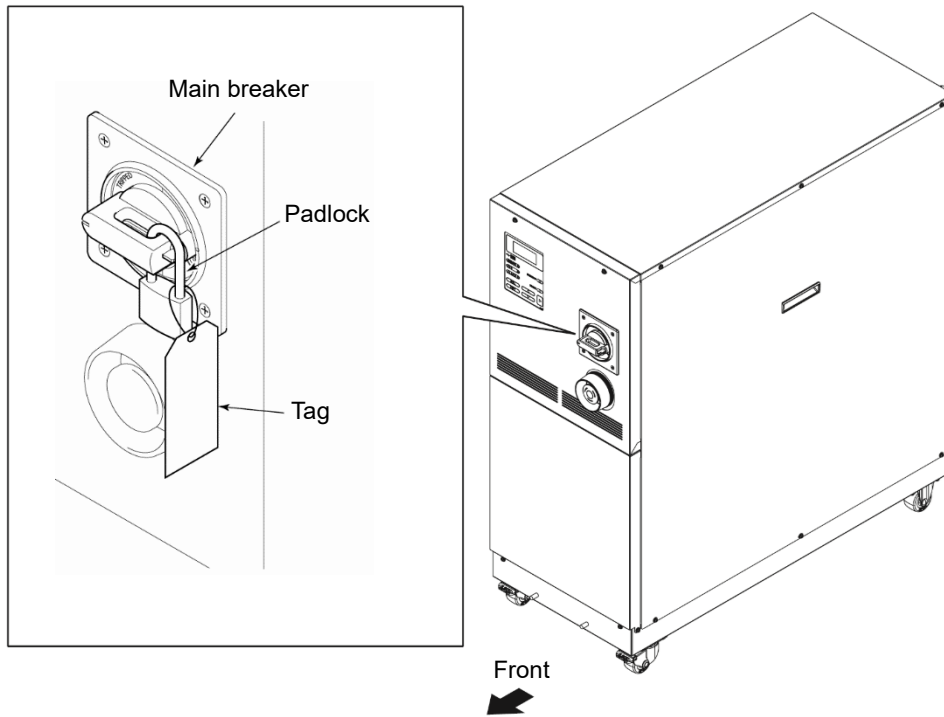

Figure 1-11 Lockout/Tagout

⚠ WARNING



- Those who engage in service of this system should build an awareness of the importance of lockout. Thorough understanding of the procedures defined in this manual are required for system service.
- Lockout is allowed only when the system come to a full stop.
- A supervisor should be appointed to direct all personnel if multiple workers engage in system service.
The supervisor is to perform lockout based on a full understanding of overall process conditions.
- Not only all personnel but new personnel that engage in service of this system should build an awareness of the importance of lockout and obtain thorough understanding of the lockout procedure.
- Any personnel working in an area with high voltage should be assigned with padlocks and tags. The key for the padlock is kept under the responsibility of the supervisor, and lockout release is performed upon completion of work.

■ Lockout procedure

⚠ WARNING



All service personnel must observe the restrictions applied during lockout and are required to perform lockout in accordance with this procedure. No service personnel is allowed to start, energize, or use the locked out system.

1. Turn the breaker handle to 'OFF O'.

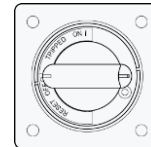

Figure 1-12 Breaker Handle at 'OFF O'

2. Turn the breaker handle to 'RESET'.

- Hold the breaker handle with hand.
The handle turns back to 'OFF O' if released.

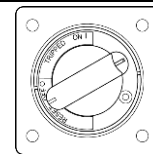

Figure 1-13 Breaker Handle at 'RESET'

3. Push the lock pushing part of the breaker handle, and turn the breaker handle to 'OFF O'.

- The lock mechanism part is to remain opened.

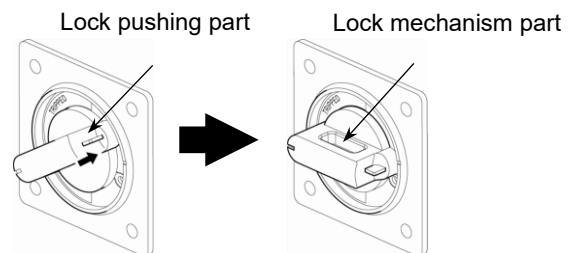

Figure 1-14 Pushing of Lock Mechanism Part

4. Lock the lock mechanism part with the padlock.

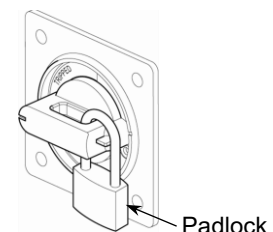

Figure 1-15 Breaker Lock

■ Releasing lockout

1. Remove the padlock from the lock mechanism part.

2. Turn the breaker handle to 'RESET'.



The lock mechanism part is closed.

- The handle turns back to 'OFF O' if released.

1.5.4 Protective equipment

This manual defines protective equipment according to work type.

Wear proper protective equipment as shown below, according to work type.

 WARNING	
	Read and understand the relevant operation manual thoroughly prior to use of protective equipment.

■ **For system transportation, installation and removal**

- Protective footwear
- Protective gloves
- Hard hat

■ **For handling circulating fluid**

- Protective footwear
- Protective gloves
- Protective mask
- Protective apron
- Protective goggles

■ **For system operation**

- Protective footwear
- Protective gloves

1.6 Emergency Measures

1.6.1 Emergency off [EMO] switch

Press the red emergency off [EMO] switch on the front of the system only if the need to shut off the power arises due to emergency such as natural disaster, fire, earthquake or personal injury.

The emergency off [EMO] switch is a large, red mushroom-shaped push button labeled with 'EMO' on it. The system comes to a halt if this button is pressed.

When press the emergency off [EMO] switch, the control power for this system is shut off to bring the system to a stop. The main breaker of this system, however, is designed not to trip, which enables the motor circuit to remain partially energized. "8.1.6Communication specification" in Chapter 8 Appendix on page 8-16 to view the circuit diagram and see how the EMO switch is interconnected to the system.

Restart of this system is enabled only when this button is reset manually.

■ Location of emergency off [EMO] switch

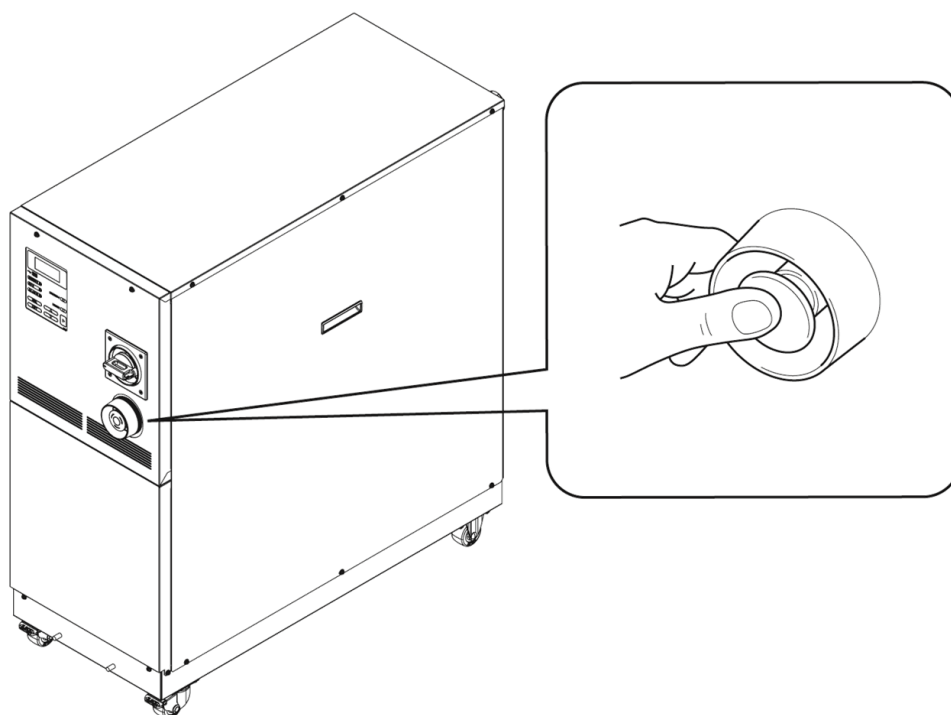



Figure 1-16 Location of Emergency Off [EMO] Switch

■ Reset of emergency off [EMO] switch

⚠ WARNING

 **No automatic recovery is applied to the emergency off [EMO] switch. Always eliminate the cause of activating the EMO before resetting. Potential serious accidents may occur if disregarded.**

1. Before restarting, always make sure that the cause of the emergency off condition (The reason why the EMO switch was activated) has been eliminated from the power supplies, the system and peripheral equipment.

-
2. With the cause completely eliminated, turn the emergency off [EMO] switch clockwise to reset.

The EMO button returns to its original position.

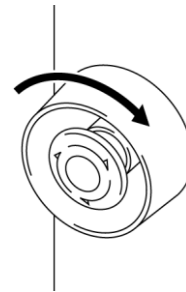



Figure 1-17 Emergency Off [EMO] Switch

⚠ WARNING

 **When the system is in remote mode, the remote mode is retained despite the power outage. Thus the system operation is to resume as the start signal is issued from your system.**

-
3. The screen then changes from the “Model Indication screen” to “Status screen 1” as power is being restored to the system.

1.7 Waste Disposal

1.7.1 Disposal of refrigerant and compressor oil

HFC- refrigerant and compressor oil are present in this system. When recovering the refrigerant or compressor oil, the precautions provided below should thoroughly be read and understood in advance. If you have any questions or concerns, contact the system supplier.

WARNING



Only service personnel or those who are qualified are allowed to open the panel of this system.

WARNING



Do not dispose of the compressor oil as domestic garbage. Incineration is permitted only at an authorized incinerator.

WARNING



Disposal of the compressor oil must be in accordance with regulations and rules of local authorities.

WARNING



The release of refrigerant into the air is prohibited by law. Recover the refrigerant with the “refrigerant recovery system”, and request the specialized waste disposal agency for disposal of the recovered refrigerant.

WARNING



Only personnel with proper licensing, who have adequate knowledge and experiences with not only this system but associated equipment are allowed to implement the recovery of the refrigerant and compressor oil.

[Tips]

For the type and quantity of the refrigerant, See “Location of Model Label” on page 1-7.

1.7.2 Circulating fluid disposal

As to the disposal of a circulating fluid (ethylene glycol solution, fluorinated fluid), consign the specialized industrial waste disposal agency with the contents detailed.

1.7.3 System disposal

As to the disposal of this system, consign the specialized industrial waste disposal agency in accordance with local laws and regulations.

1.7.4 Label

Label described below which is attached to the top panel of product is that required by Japanese law, and the content of this label is applicable in Japan only.

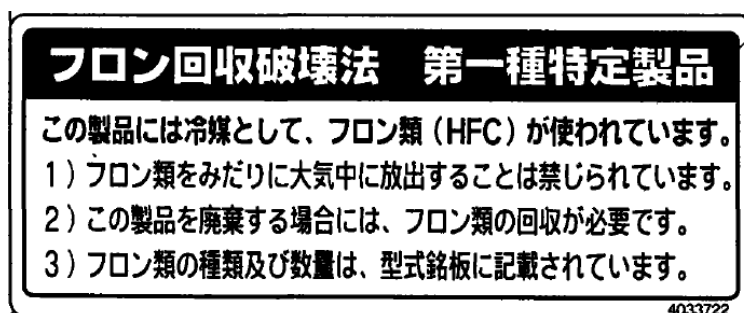

Contents of description of this label is shown as follows.

Fluorocarbon Collection and Destruction Law in Japan

This product uses Fluorocarbon (HFC) as a refrigerant.

1. It is strictly forbidden to emit Fluorocarbon to the atmosphere.
2. When disposing this product, Fluorocarbon must be collected in an appropriate manner.
3. This kind of Fluorocarbon and the amount used in this product is printed on the name label.

1.8 Material Safety Data Sheet (SDS)

Any chemicals used by the user must be accompanied by an SDS.

⚠ WARNING



【About Contents】

- Contents documented here are based on references, information and data available so far. Information given regarding physical/chemical properties, hazard and toxicity here gives no guarantee.
- Also, be noted that cautions are for normal handling. Carry out sufficient safety, hygiene, and environmental measures for special handling.
- Note the items described as “no documentation” mean our study on those items is not completed yet.

1.8.1 Galden® HT135

SAFETY DATA SHEET

GALDEN® HT135

Revision Date 2015-09-29

SECTION 1: Identification of the substance/mixture and of the company/undertaking

1.1 Product identifier

- Trade name GALDEN® HT135

1.2 Relevant identified uses of the substance or mixture and uses advised against

Uses of the Substance/Mixture

- Heat transfer medium
- For industrial use only.

1.3 Details of the supplier of the safety data sheet

Company

SOLVAY SPECIALTY POLYMERS JAPAN K.K.
7TH FL, ATAGO GREEN HILLS MORI TOWER
ATAGO 2-5-1, MINATO-KU
105-6207, TOKYO
JAPAN
Tel: +81-3-54254300 / 4330
Fax: +81-3-54254321

E-mail address

sds.solvay@solvay.com

1.4 Emergency telephone number

- +81 345 789 341 [Carechem 24]

SECTION 2: Hazards identification

2.1 Classification of the substance or mixture

Classification (JIS Z 7252) and Hazard communication (JIS Z 7253) based on GHS.

- Not classified as hazardous product according to JIS Z 7252.

2.2 Label elements

Classification (JIS Z 7252) and Hazard communication (JIS Z 7253) based on GHS.

- No GHS labelling required according to JIS Z 7253.

2.3 Other hazards which do not result in classification

- Thermal decomposition can lead to release of toxic and corrosive gases.

SECTION 3: Composition/information on ingredients

3.1 Substance

- Chemical nature Perfluorinated polyethers

P03000018312
Version : 1.08 / JP (EN)
www.solvay.com

1 / 12



SAFETY DATA SHEET

GALDEN® HT135

Revision Date 2015-09-29

Information on Components and Impurities

Chemical Name	CAS-No.	Number on official gazette	Concentration [%]
Perfluorinated polyether	*****	*****	> 99.9

3.2 Mixture

- Not applicable, this product is a substance.

SECTION 4: First aid measures

4.1 Description of first aid measures

In case of inhalation

- Move to fresh air in case of accidental inhalation of fumes from overheating or combustion.
- Oxygen or artificial respiration if needed.

In case of skin contact

- Wash off with soap and water.

In case of eye contact

- Rinse immediately with plenty of water, also under the eyelids, for at least 15 minutes.
- If eye irritation persists, consult a specialist.

In case of ingestion

- Drink 1 or 2 glasses of water.
- Do NOT induce vomiting.
- If symptoms persist, call a physician.

4.2 Most important symptoms and effects, both acute and delayed

In case of inhalation**Effects**

- No known effect.

In case of skin contact**Effects**

- Effects of skin contacts may include:
- Redness

In case of eye contact**Effects**

- Contact with eyes may cause irritation.
- Redness

In case of ingestion**Symptoms**

- Ingestion may provoke the following symptoms:
- Nausea
- Vomiting
- Diarrhoea

4.3 Indication of any immediate medical attention and special treatment needed

Notes to physician

- None

P03000018312
Version : 1.08 / JP (EN)
www.solvay.com



2 / 12

SAFETY DATA SHEET

GALDEN® HT135

Revision Date 2015-09-29

SECTION 5: Firefighting measures

5.1 Extinguishing media

Suitable extinguishing media

- Water
- powder
- Foam
- Dry chemical
- Carbon dioxide (CO₂)

Unsuitable extinguishing media

- None

5.2 Special hazards arising from the substance or mixture

- The product is not flammable.
- Not explosive
- In case of fire hazardous decomposition products may be produced such as: Gaseous hydrogen fluoride (HF), Fluorophosgene

5.3 Advice for firefighters

Special protective equipment for firefighters

- Wear self-contained breathing apparatus and protective suit.
- When intervention in close proximity wear acid resistant over suit.

Further information

- Evacuate personnel to safe areas.
- Approach from upwind.
- Protect intervention team with a water spray as they approach the fire.
- Keep containers and surroundings cool with water spray.
- Keep product and empty container away from heat and sources of ignition.

SECTION 6: Accidental release measures

6.1 Personal precautions, protective equipment and emergency procedures

Advice for non-emergency personnel

- Prevent further leakage or spillage if safe to do so.

Advice for emergency responders

- Ensure adequate ventilation.
- Material can create slippery conditions.
- Sweep up to prevent slipping hazard.
- Keep away from open flames, hot surfaces and sources of ignition.

6.2 Environmental precautions

- Should not be released into the environment.
- Do not flush into surface water or sanitary sewer system.

6.3 Methods and materials for containment and cleaning up

- Soak up with inert absorbent material.
- Suitable material for picking up.
- Dry sand
- Earth
- Shovel into suitable container for disposal.

6.4 Reference to other sections

P03000018312
Version : 1.08 / JP (EN)

www.solvay.com

3 / 12



SAFETY DATA SHEET

GALDEN® HT135

Revision Date 2015-09-29

- Refer to protective measures listed in sections 7 and 8.

SECTION 7: Handling and storage**7.1 Precautions for safe handling**

- Ensure adequate ventilation.
- Use personal protective equipment.
- Keep away from heat and sources of ignition.
- To avoid thermal decomposition, do not overheat.
- Take measures to prevent the build up of electrostatic charge.
- Clean and dry piping circuits and equipment before any operations.
- Ensure all equipment is electrically grounded before beginning transfer operations.

Hygiene measures

- Ensure that eyewash stations and safety showers are close to the workstation location.
- When using do not eat, drink or smoke.
- Wash hands before breaks and at the end of workday.
- Handle in accordance with good industrial hygiene and safety practice.

7.2 Conditions for safe storage, including any incompatibilities**Technical measures/Storage conditions**

- Keep away from heat and sources of ignition.
- Keep in properly labelled containers.
- Keep away from combustible material.
- Keep away from incompatible products
- Provide tight electrical equipment well protected against corrosion.
- Refer to protective measures listed in sections 7 and 8.

Packaging material**Suitable material**

- Plastic materials.
- glass

7.3 Specific end use(s)

- Contact your supplier for additional information

SECTION 8: Exposure controls/personal protection**8.1 Control parameters**

- We are not aware of any national exposure limit.

P03000018312
Version : 1.08 / JP (EN)
www.solvay.com

4 / 12



SAFETY DATA SHEET

GALDEN® HT135

Revision Date 2015-09-29

Threshold limit values of by-products from thermal decomposition:

Components with official national occupational exposure limits

Components	Value type	Value	Basis
hydrogen fluoride	ACL	0.5 ppm	Japan. Administrative Control Levels

Components with other national occupational exposure limits

Components	Value type	Value	Basis
hydrogen fluoride	OEL-C	3 ppm 2.5 mg/m3	Japan. The Japan Society for Occupational Health. Recommendation of Occupational Exposure Limits

Components with other occupational exposure limits

Components	Value type	Value	Basis
hydrogen fluoride	TWA	0.5 ppm	USA. ACGIH Threshold Limit Values (TLV)
		Danger of cutaneous absorption Expressed as :Fluorine	
hydrogen fluoride	C	2 ppm	USA. ACGIH Threshold Limit Values (TLV)
		Danger of cutaneous absorption Expressed as :Fluorine	
carbonyl difluoride	TWA	2 ppm	USA. ACGIH Threshold Limit Values (TLV)
carbonyl difluoride	STEL	5 ppm	USA. ACGIH Threshold Limit Values (TLV)

Biological Exposure Indices

Components	Value type	Value	Basis
hydrogen fluoride	BEI	2 mg/l Fluoride Urine Prior to shift (16 hours after exposure ceases)	ACGIH - Biological Exposure Indices (BEI)
hydrogen fluoride	BEI	3 mg/l Fluoride Urine End of shift (As soon as possible after exposure ceases)	ACGIH - Biological Exposure Indices (BEI)

P03000018312
Version : 1.08 / JP (EN)
www.solvay.com

5 / 12



SAFETY DATA SHEET

GALDEN® HT135

Revision Date 2015-09-29

8.2 Exposure controls

Control measures**Engineering measures**

- Provide local ventilation appropriate to the product decomposition risk (see section 10).
- Refer to protective measures listed in sections 7 and 8.
- Apply technical measures to comply with the occupational exposure limits.

Individual protection measures**Respiratory protection**

- In case of decomposition (see section 10), use an air breathing apparatus with face mask.
- Use only respiratory protection that conforms to international/ national standards.

Hand protection

- Wear protective gloves.

Suitable material

- Nitrile rubber
- PVC
- Neoprene gloves
- butyl-rubber

- Take note of the information given by the producer concerning permeability and break through times, and of special workplace conditions (mechanical strain, duration of contact).

Eye protection

- Tightly fitting safety goggles

Skin and body protection

- Wear work overall and safety shoes.

Hygiene measures

- Ensure that eyewash stations and safety showers are close to the workstation location.
- When using do not eat, drink or smoke.
- Wash hands before breaks and at the end of workday.
- Handle in accordance with good industrial hygiene and safety practice.

Environmental exposure controls

- Dispose of rinse water in accordance with local and national regulations.

SECTION 9: Physical and chemical properties

9.1 Information on basic physical and chemical properties

Appearance	Physical state: liquid
	Colour: colourless
Odour	odourless
Odour Threshold	no data available
pH	no data available
Melting point/range	Not applicable
Boiling point/boiling range	135 °C
Flash point	The product is not flammable.
Evaporation rate (Butylacetate = 1)	no data available
Flammability (liquids)	The product is not flammable.
Flammability/Explosive limit	no data available

P03000018312
Version : 1.08 / JP (EN)
www.solvay.com

6 / 12



SAFETY DATA SHEET

GALDEN® HT135

Revision Date 2015-09-29

<u>Auto-ignition temperature</u>	no data available
<u>Vapour pressure</u>	ca. 7.73 hPa
<u>Vapour density</u>	no data available
<u>Density</u>	1.72 g/cm ³ (25 °C)
<u>Solubility</u>	<u>Water solubility</u> : insoluble
	<u>Solubility in other solvents</u> : Fluorinated solvents : insoluble
<u>Partition coefficient: n-octanol/water</u>	no data available
<u>Thermal decomposition</u>	> 290 °C
<u>Viscosity</u>	<u>Viscosity_dynamic</u> : ca. 1.72 mPa.s
<u>Explosive properties</u>	Not explosive
<u>Oxidizing properties</u>	Not considered as oxidizing

9.2 Other information

<u>Molecular weight</u>	610 Da Polymer Molar Mass
-------------------------	------------------------------

SECTION 10: Stability and reactivity

10.1 Reactivity

- No dangerous reaction known under conditions of normal use.

10.2 Chemical stability

- Stable under recommended storage conditions.
- Metals promote and lower decomposition temperature

10.3 Possibility of hazardous reactions

- No dangerous reaction known under conditions of normal use.

10.4 Conditions to avoid

- Avoid to use in presence of high voltage electric arc and in absence of oxygen.
- Keep away from flames.
- To avoid thermal decomposition, do not overheat.

10.5 Incompatible materials

- Alkali metals
- Lewis acids (Friedel-Crafts) above 100°C
- Aluminum and magnesium in powder form above 200°C

10.6 Hazardous decomposition products

- Gaseous hydrogen fluoride (HF).
- Fluorophosgene

P03000018312
Version : 1.08 / JP (EN)

www.solvay.com

7 / 12



SAFETY DATA SHEET

GALDEN® HT135

Revision Date 2015-09-29

SECTION 11: Toxicological information**11.1 Information on toxicological effects****Acute toxicity****Acute oral toxicity**

LD50 : > 15,000 mg/kg - Rat , male and female
 Method: OECD Test Guideline 401
 Test substance: Molecular weight ~ 650
 Not classified as hazardous for acute oral toxicity according to GHS.
 No effect observed at this dose or concentration

Acute inhalation toxicity

LC50 - 4 h (vapour) : > 66.6 mg/l - Rat , male and female
 Method: OECD Test Guideline 403
 Test substance: Molecular weight ~ 650
 Not classified as hazardous for acute inhalation toxicity according to GHS.
 no observed effect

Acute dermal toxicity

LD50 : > 5,000 mg/kg - Rat , male and female
 Method: OECD Test Guideline 402
 Test substance: Molecular weight ~ 650
 Not classified as hazardous for acute dermal toxicity according to GHS.
 No effect observed at this dose or concentration
 no data available

Acute toxicity (other routes of administration)

no data available

Skin corrosion/irritation

Rabbit
 Not classified as irritating to skin
 Method: OECD Test Guideline 404
 Test substance: Molecular weight ~ 650
 2 Weeks - Rabbit
 No skin irritation
 Method: Repeated dermal application test.
 Test substance: Molecular weight ~ 650

Serious eye damage/eye irritation

Rabbit
 Not classified as irritating to eyes
 Method: OECD Test Guideline 405
 Test substance: Molecular weight ~ 650
 Unpublished internal reports

Respiratory or skin sensitisation

Buehler Test - Guinea pig
 Does not cause skin sensitisation.
 Method: OECD Test Guideline 406
 Test substance: Molecular weight ~ 650
 Unpublished internal reports

P03000018312
 Version : 1.08 / JP (EN)

www.solvay.com

8 / 12



SAFETY DATA SHEET

GALDEN® HT135

Revision Date 2015-09-29

Mutagenicity

Genotoxicity in vitro

Ames test
with and without metabolic activation

negative
Method: OECD Test Guideline 471
Test substance: Molecular weight ~ 650
Chromosome aberration test in vitro
with and without metabolic activation

negative
Method: OECD Test Guideline 473
Test substance: Molecular weight ~ 650

Genotoxicity in vivo

In vivo micronucleus test - Rat
male
Oral
Method: OECD Test Guideline 474
Test substance: Molecular weight ~ 650

negative

Carcinogenicity

no data available

Toxicity for reproduction and development

Toxicity to reproduction/Fertility no data available
Developmental Toxicity/Teratogenicity no data available

STOT

STOT - single exposure

The substance or mixture is not classified as specific target organ toxicant, single exposure according to GHS criteria.

STOT - repeated exposure

no data available

CMR effects

Mutagenicity

The product is considered to be non-mutagenic based on an overall assessment of the data from animal and/or in vitro testing.

Aspiration toxicity

no data available

Further information

Description of possible hazardous to health effects is based on experience and/or toxicological characteristics of several components.
Thermal decomposition can lead to release of toxic and corrosive gases.
The exposure to decomposition products causes severe irritation of eyes, skin and mucous membranes.

P03000018312
Version : 1.08 / JP (EN)
www.solvay.com

9 / 12



SAFETY DATA SHEET

GALDEN® HT135

Revision Date 2015-09-29

SECTION 12: Ecological information**12.1 Toxicity****Aquatic Compartment****Acute toxicity to fish**

By analogy
No toxicity at the limit of solubility

Acute toxicity to daphnia and other aquatic invertebrates.

By analogy
No toxicity at the limit of solubility

12.2 Persistence and degradability**Degradability assessment**

The product is not considered to be rapidly degradable in the environment

12.3 Bioaccumulative potential

no data available

12.4 Mobility in soil

no data available

12.5 Results of PBT and vPvB assessment

no data available

12.6 Other adverse effects

no data available

Ecotoxicity assessment**Acute aquatic toxicity**

No toxicity at the limit of solubility

Remarks

Ecological injuries are not known or expected under normal use.

SECTION 13: Disposal considerations**13.1 Waste treatment methods****Product Disposal**

- Can be incinerated, when in compliance with local regulations.
- The incinerator must be equipped with a system for the neutralisation or recovery of HF.
- Dispose of in accordance with local regulations.

Advice on cleaning and disposal of packaging

- Empty containers can be landfilled, when in accordance with the local regulations.

SECTION 14: Transport information**Local regulation**

not regulated

International transport regulations

P03000018312
Version : 1.08 / JP (EN)
www.solvay.com



10 / 12

SAFETY DATA SHEET

GALDEN® HT135

Revision Date 2015-09-29

IMDG
not regulated

IATA
not regulated

Note: The above regulatory prescriptions are those valid on the date of publication of this sheet. Given the possible evolution of transport regulations for hazardous materials, it would be advisable to check their validity with your sales office.

SECTION 15: Regulatory information

15.1 Safety, health and environmental regulations/legislation specific for the substance or mixture

ISHL Substances Subject to be Notified Names	Not relevant
Poisonous and Deleterious Substances Control Law	Not relevant
Act on Confirmation, etc. of Release Amounts of Specific Chemical Substances in the Environment and Promotion of Improvements to the Management Thereof	Not relevant

Notification status

Inventory Information	Status
United States TSCA Inventory	- Listed on Inventory
Canadian Domestic Substances List (DSL)	- Listed on Inventory
Australia Inventory of Chemical Substances (AICS)	- Listed on Inventory
Korea. Korean Existing Chemicals Inventory (KECI)	- Listed on Inventory
China. Inventory of Existing Chemical Substances in China (IECSC)	- Listed on Inventory
Japan. ISHL - Inventory of Chemical Substances	- Listed on Inventory
Japan. CSCL - Inventory of Existing and New Chemical Substances	- Listed on Inventory
Philippines Inventory of Chemicals and Chemical Substances (PICCS)	- Listed on Inventory
New Zealand. Inventory of Chemical Substances	- Listed on Inventory
Taiwan. Chemical Substance Inventory (TCSI)	- Listed on Inventory
EU. European Registration, Evaluation, Authorisation and Restriction of Chemical (REACH)	- If product is purchased from Solvay in Europe it is in compliance with REACH, if not please contact the supplier.

SECTION 16: Other information

P03000018312
Version : 1.08 / JP (EN)

www.solvay.com

11 / 12



SAFETY DATA SHEET

GALDEN® HT135

Revision Date 2015-09-29

Key or legend to abbreviations and acronyms used in the safety data sheet

- ACL	Administrative Control level
- C	Ceiling limit
- OEL-C	Occupational Exposure Limit-Ceiling
- STEL	Short-term exposure limit
- TWA	8-hour, time-weighted average

The information provided in this Safety Data Sheet is correct to the best of our knowledge, information and belief at the date of its publication. Such information is only given as a guidance to help the user handle, use, process, store, transport, dispose and release the product in satisfactory safety conditions and is not to be considered as a warranty or quality specification. It should be used in conjunction with technical sheets but do not replace them. Thus, the information only relates to the designated specific product and may not be applicable if such product is used in combination with other materials or in any other manufacturing process, unless otherwise specifically indicated. It does not release the user from ensuring he is in conformity with all regulations linked to its activity.

P03000018312
Version : 1.08 / JP (EN)

www.solvay.com

12 / 12



1.8.2 Fluorinert™ FC-3283

3M™ Fluorinert™ Electronic Liquid FC-3283 09/06/16



Safety Data Sheet

Copyright, 2016, 3M Company.

All rights reserved. Copying and/or downloading of this information for the purpose of properly utilizing 3M products is allowed provided that: (1) the information is copied in full with no changes unless prior written agreement is obtained from 3M, and (2) neither the copy nor the original is resold or otherwise distributed with the intention of earning a profit thereon.

Document Group:	06-4521-8	Version Number:	31.04
Issue Date:	09/06/16	Supersedes Date:	10/13/15

SECTION 1: Identification

1.1. Product identifier

3M™ Fluorinert™ Electronic Liquid FC-3283

Product Identification Numbers

98-0212-2908-7, 98-0212-4878-0, 98-0212-4879-8, 98-0212-4880-6, HB-0042-0654-4, ZF-0002-1344-5, ZF-0002-1345-2, ZF-0002-1356-9

1.2. Recommended use and restrictions on use

Recommended use

For Industrial Use Only. Not Intended for Use as a Medical Device or Drug., Testing Fluid or Heat Transfer Fluid for Electronics

Restrictions on use

Fluorinert™ Electronic Liquids are used in a wide variety of applications, including but not limited to precision cleaning of medical devices and as lubricant deposition solvents for medical devices. When the product is used for applications where the finished device is implanted into the human body, no residual Fluorinert solvent may remain on the parts. It is highly recommended that the supporting test results and protocol be cited during FDA registration.

3M Electronics Markets Materials Division (EMMD) will not knowingly sample, support, or sell its products for incorporation in medical and pharmaceutical products and applications in which the 3M product will be temporarily or permanently implanted into humans or animals. The customer is responsible for evaluating and determining that a 3M EMMD product is suitable and appropriate for its particular use and intended application. The conditions of evaluation, selection, and use of a 3M product can vary widely and affect the use and intended application of a 3M product. Because many of these conditions are uniquely within the user's knowledge and control, it is essential that the user evaluate and determine whether the 3M product is suitable and appropriate for a particular use and intended application, and complies with all local applicable laws, regulations, standards, and guidance.

1.3. Supplier's details

MANUFACTURER:	3M
DIVISION:	Electronics Materials Solutions Division
ADDRESS:	3M Center, St. Paul, MN 55144-1000, USA
Telephone:	1-888-3M HELPS (1-888-364-3577)

1.4. Emergency telephone number

1-800-364-3577 or (651) 737-6501 (24 hours)

SECTION 2: Hazard identification

3M™ Fluorinert™ Electronic Liquid FC-3283 09/06/16
--

2.1. Hazard classification

Not classified as hazardous according to OSHA Hazard Communication Standard, 29 CFR 1910.1200.

2.2. Label elements**Signal word**

Not applicable.

Symbols

Not applicable.

Pictograms

Not applicable.

2.3. Hazards not otherwise classified

None.

SECTION 3: Composition/information on ingredients

Ingredient	C.A.S. No.	% by Wt
Perfluoro compounds (primarily compounds with 9 carbons)	86508-42-1	100

SECTION 4: First aid measures**4.1. Description of first aid measures****Inhalation:**

No need for first aid is anticipated.

Skin Contact:

Wash with soap and water. If signs/symptoms develop, get medical attention.

Eye Contact:

Flush with large amounts of water. Remove contact lenses if easy to do. Continue rinsing. If signs/symptoms persist, get medical attention.

If Swallowed:

Rinse mouth. If you feel unwell, get medical attention.

4.2. Most important symptoms and effects, both acute and delayed

See Section 11.1. Information on toxicological effects.

4.3. Indication of any immediate medical attention and special treatment required

Not applicable

SECTION 5: Fire-fighting measures**5.1. Suitable extinguishing media**

Material will not burn. Use a fire fighting agent suitable for the surrounding fire.

5.2. Special hazards arising from the substance or mixture

Exposure to extreme heat can give rise to thermal decomposition.

3M™ Fluorinert™ Electronic Liquid FC-3283 09/06/16

Hazardous Decomposition or By-Products

<u>Substance</u>	<u>Condition</u>
Carbon monoxide	During Combustion
Carbon dioxide	During Combustion

5.3. Special protective actions for fire-fighters

When fire fighting conditions are severe and total thermal decomposition of the product is possible, wear full protective clothing, including helmet, self-contained, positive pressure or pressure demand breathing apparatus, bunker coat and pants, bands around arms, waist and legs, face mask, and protective covering for exposed areas of the head.

SECTION 6: Accidental release measures

6.1. Personal precautions, protective equipment and emergency procedures

Evacuate area. Ventilate the area with fresh air. For large spill, or spills in confined spaces, provide mechanical ventilation to disperse or exhaust vapors, in accordance with good industrial hygiene practice. Refer to other sections of this SDS for information regarding physical and health hazards, respiratory protection, ventilation, and personal protective equipment.

6.2. Environmental precautions

Avoid release to the environment. For larger spills, cover drains and build dikes to prevent entry into sewer systems or bodies of water.

6.3. Methods and material for containment and cleaning up

Contain spill. Working from around the edges of the spill inward, cover with bentonite, vermiculite, or commercially available inorganic absorbent material. Mix in sufficient absorbent until it appears dry. Remember, adding an absorbent material does not remove a physical, health, or environmental hazard. Collect as much of the spilled material as possible. Place in a closed container approved for transportation by appropriate authorities. Clean up residue with an appropriate solvent selected by a qualified and authorized person. Ventilate the area with fresh air. Read and follow safety precautions on the solvent label and SDS. Seal the container. Dispose of collected material as soon as possible.

SECTION 7: Handling and storage

7.1. Precautions for safe handling

Do not breathe thermal decomposition products. Avoid skin contact with hot material. For industrial or professional use only. Store work clothes separately from other clothing, food and tobacco products. Do not eat, drink or smoke when using this product. Wash thoroughly after handling. No smoking: Smoking while using this product can result in contamination of the tobacco and/or smoke and lead to the formation of hazardous decomposition products.

7.2. Conditions for safe storage including any incompatibilities

Store away from heat.

SECTION 8: Exposure controls/personal protection

8.1. Control parameters

Occupational exposure limits

No occupational exposure limit values exist for any of the components listed in Section 3 of this SDS.

8.2. Exposure controls

8.2.1. Engineering controls

Provide appropriate local exhaust when product is heated.

8.2.2. Personal protective equipment (PPE)

3M™ Fluorinert™ Electronic Liquid FC-3283 09/06/16
--

Eye/face protection

None required.

Skin/hand protection

Select and use gloves and/or protective clothing approved to relevant local standards to prevent skin contact based on the results of an exposure assessment. Selection should be based on use factors such as exposure levels, concentration of the substance or mixture, frequency and duration, physical challenges such as temperature extremes, and other use conditions. Consult with your glove and/or protective clothing manufacturer for selection of appropriate compatible gloves/protective clothing. Note: Nitrile gloves may be worn over polymer laminate gloves to improve dexterity.

Gloves made from the following material(s) are recommended: Polymer laminate

Respiratory protection

During heating:

Use a positive pressure supplied-air respirator if there is a potential for over exposure from an uncontrolled release, exposure levels are not known, or under any other circumstances where air-purifying respirators may not provide adequate protection.

Thermal hazards

Wear heat insulating gloves when handling hot material to prevent thermal burns.

SECTION 9: Physical and chemical properties
--

9.1. Information on basic physical and chemical properties

General Physical Form:	Liquid
Specific Physical Form:	Liquid
Odor, Color, Grade:	Colorless, odorless liquid.
Odor threshold	<i>No Data Available</i>
pH	<i>Not Applicable</i>
Melting point	<i>Not Applicable</i>
Boiling Point	123 - 133 °C
Flash Point	No flash point
Evaporation rate	< 1 [<i>Ref Std: BUOAC=1</i>]
Flammability (solid, gas)	Not Applicable
Flammable Limits(LEL)	None detected
Flammable Limits(UEL)	None detected
Vapor Pressure	14 mmHg [<i>@ 23 °C</i>]
Vapor Density	18 [<i>@ 23 °C</i>] [<i>Ref Std: AIR=1</i>]
Density	1.8 g/ml
Specific Gravity	1.8 [<i>Ref Std: WATER=1</i>]
Solubility in Water	Nil
Solubility- non-water	<i>No Data Available</i>
Partition coefficient: n-octanol/ water	<i>No Data Available</i>
Autoignition temperature	<i>No Data Available</i>
Decomposition temperature	<i>Not Applicable</i>
Viscosity	0.7 centistoke [<i>@ 25 °C</i>]
Molecular weight	<i>No Data Available</i>
Volatile Organic Compounds	[<i>Details: Exempt</i>]
Percent volatile	100 %
VOC Less H ₂ O & Exempt Solvents	[<i>Details: Exempt</i>]

SECTION 10: Stability and reactivity

10.1. Reactivity

3M™ Fluorinert™ Electronic Liquid FC-3283 09/06/16

This material may be reactive with certain agents under certain conditions - see the remaining headings in this section.

10.2. Chemical stability

Stable.

10.3. Possibility of hazardous reactions

Hazardous polymerization will not occur.

10.4. Conditions to avoid

Heat

10.5. Incompatible materials

Finely divided active metals
Alkali and alkaline earth metals

10.6. Hazardous decomposition products

<u>Substance</u>	<u>Condition</u>
Hydrogen Fluoride	At Elevated Temperatures - greater than 200 °C
Perfluoroisobutylene (PFIB)	At Elevated Temperatures - greater than 200 °C

Refer to section 5.2 for hazardous decomposition products during combustion.

If the product is exposed to extreme condition of heat from misuse or equipment failure, toxic decomposition products that include hydrogen fluoride and perfluoroisobutylene can occur.

SECTION 11: Toxicological information

The information below may not be consistent with the material classification in Section 2 if specific ingredient classifications are mandated by a competent authority. In addition, toxicological data on ingredients may not be reflected in the material classification and/or the signs and symptoms of exposure, because an ingredient may be present below the threshold for labeling, an ingredient may not be available for exposure, or the data may not be relevant to the material as a whole.

11.1. Information on Toxicological effects

Signs and Symptoms of Exposure

Based on test data and/or information on the components, this material may produce the following health effects:

Inhalation:

No known health effects.

Skin Contact:

Contact with the skin during product use is not expected to result in significant irritation.

Eye Contact:

Contact with the eyes during product use is not expected to result in significant irritation.

Ingestion:

May be harmful if swallowed.

Additional Information:

A Material Toxicity Summary Sheet (MTSS) has been developed for this product. Please contact the address listed on the first

3M™ Fluorinert™ Electronic Liquid FC-3283 09/06/16

page of this MSDS to obtain a copy of the MTSS for this product.

Toxicological Data

If a component is disclosed in section 3 but does not appear in a table below, either no data are available for that endpoint or the data are not sufficient for classification.

Acute Toxicity

Name	Route	Species	Value
Perfluoro compounds (primarily compounds with 9 carbons)	Dermal		LD50 estimated to be > 5,000 mg/kg
Perfluoro compounds (primarily compounds with 9 carbons)	Inhalation-Vapor (4 hours)	Rat	LC50 > 41 mg/l
Perfluoro compounds (primarily compounds with 9 carbons)	Ingestion	Rat	LD50 > 5,000 mg/kg

ATE = acute toxicity estimate

Skin Corrosion/Irritation

Name	Species	Value
Perfluoro compounds (primarily compounds with 9 carbons)	Rabbit	No significant irritation

Serious Eye Damage/Irritation

Name	Species	Value
Perfluoro compounds (primarily compounds with 9 carbons)	Rabbit	No significant irritation

Skin Sensitization

For the component/components, either no data are currently available or the data are not sufficient for classification.

Respiratory Sensitization

For the component/components, either no data are currently available or the data are not sufficient for classification.

Germ Cell Mutagenicity

Name	Route	Value
Perfluoro compounds (primarily compounds with 9 carbons)	In Vitro	Not mutagenic

Carcinogenicity

For the component/components, either no data are currently available or the data are not sufficient for classification.

Reproductive Toxicity

Reproductive and/or Developmental Effects

For the component/components, either no data are currently available or the data are not sufficient for classification.

Target Organ(s)

Specific Target Organ Toxicity - single exposure

For the component/components, either no data are currently available or the data are not sufficient for classification.

Specific Target Organ Toxicity - repeated exposure

Name	Route	Target Organ(s)	Value	Species	Test Result	Exposure Duration
Perfluoro compounds (primarily compounds with 9 carbons)	Inhalation	heart endocrine system bone, teeth, nails, and/or hair hematopoietic system liver immune system nervous system	All data are negative	Rat	NOAEL 49,821 ppm	13 weeks

3M™ Fluorinert™ Electronic Liquid FC-3283 09/06/16

		eyes kidney and/or bladder respiratory system				
Perfluoro compounds (primarily compounds with 9 carbons)	Ingestion	heart endocrine system hematopoietic system liver nervous system kidney and/or bladder respiratory system	All data are negative	Rat	NOAEL 2,000 mg/kg/day	28 days

Aspiration Hazard

For the component/components, either no data are currently available or the data are not sufficient for classification.

Please contact the address or phone number listed on the first page of the SDS for additional toxicological information on this material and/or its components.

SECTION 12: Ecological information

Ecotoxicological information

Please contact the address or phone number listed on the first page of the SDS for additional ecotoxicological information on this material and/or its components.

Chemical fate information

Please contact the address or phone number listed on the first page of the SDS for additional chemical fate information on this material and/or its components.

SECTION 13: Disposal considerations

13.1. Disposal methods

Dispose of contents/ container in accordance with the local/regional/national/international regulations.

Dispose of waste product in a permitted industrial waste facility. Combustion products will include HF. Facility must be capable of handling halogenated materials.

Empty drums/barrels/containers used for transporting and handling hazardous chemicals (chemical substances/mixtures/preparations classified as Hazardous as per applicable regulations) shall be considered, stored, treated & disposed of as hazardous wastes unless otherwise defined by applicable waste regulations. Consult with the respective regulating authorities to determine the available treatment and disposal facilities.

EPA Hazardous Waste Number (RCRA): Not regulated

SECTION 14: Transport Information

Not regulated per U.S. DOT, IATA or IMO.

These transportation classifications are provided as a customer service. As the shipper YOU remain responsible for complying with all applicable laws and regulations, including proper transportation classification and packaging. 3M transportation classifications are based on product formulation, packaging, 3M policies and 3M understanding of applicable current regulations. 3M does not guarantee the accuracy of this classification information. This information applies only to transportation classification and not the packaging, labeling, or marking requirements. The original 3M package is certified for U.S. ground shipment only. If you are shipping by air or ocean, the package may not meet applicable regulatory requirements.

SECTION 15: Regulatory information

3M™ Fluorinert™ Electronic Liquid FC-3283 09/06/16
--

15.1. US Federal Regulations

Contact 3M for more information.

311/312 Hazard Categories:

Fire Hazard - No Pressure Hazard - No Reactivity Hazard - No Immediate Hazard - Yes Delayed Hazard - No

15.2. State Regulations

Contact 3M for more information.

15.3. Chemical Inventories

The components of this material are in compliance with the provisions of Australia National Industrial Chemical Notification and Assessment Scheme (NICNAS). Certain restrictions may apply. Contact the selling division for additional information.

The components of this product are in compliance with the new substance notification requirements of CEPA.

The components of this material are in compliance with the China "Measures on Environmental Management of New Chemical Substance". Certain restrictions may apply. Contact the selling division for additional information.

The components of this material are in compliance with the provisions of Philippines RA 6969 requirements. Certain restrictions may apply. Contact the selling division for additional information.

The components of this product are in compliance with the chemical notification requirements of TSCA.

Contact 3M for more information.

15.4. International Regulations

Contact 3M for more information.

This SDS has been prepared to meet the U.S. OSHA Hazard Communication Standard, 29 CFR 1910.1200.

SECTION 16: Other information**NFPA Hazard Classification**

Health: 3 **Flammability:** 0 **Instability:** 0 **Special Hazards:** None

National Fire Protection Association (NFPA) hazard ratings are designed for use by emergency response personnel to address the hazards that are presented by short-term, acute exposure to a material under conditions of fire, spill, or similar emergencies. Hazard ratings are primarily based on the inherent physical and toxic properties of the material but also include the toxic properties of combustion or decomposition products that are known to be generated in significant quantities.

HMIS Hazard Classification

Health: 0 **Flammability:** 0 **Physical Hazard:** 0 **Personal Protection:** X - See PPE section.

Hazardous Material Identification System (HMIS® IV) hazard ratings are designed to inform employees of chemical hazards in the workplace. These ratings are based on the inherent properties of the material under expected conditions of normal use and are not intended for use in emergency situations. HMIS® IV ratings are to be used with a fully implemented HMIS® IV program. HMIS® is a registered mark of the American Coatings Association (ACA).

Document Group:	06-4521-8	Version Number:	31.04
Issue Date:	09/06/16	Supersedes Date:	10/13/15

Reason for Reissue

3M™ Fluorinert™ Electronic Liquid FC-3283 09/06/16

Conversion to GHS format SDS.

DISCLAIMER: The information in this Safety Data Sheet (SDS) is believed to be correct as of the date issued. 3M MAKES NO WARRANTIES, EXPRESSED OR IMPLIED, INCLUDING, BUT NOT LIMITED TO, ANY IMPLIED WARRANTY OF MERCHANTABILITY OR FITNESS FOR A PARTICULAR PURPOSE OR COURSE OF PERFORMANCE OR USAGE OF TRADE. User is responsible for determining whether the 3M product is fit for a particular purpose and suitable for user's method of use or application. Given the variety of factors that can affect the use and application of a 3M product, some of which are uniquely within the user's knowledge and control, it is essential that the user evaluate the 3M product to determine whether it is fit for a particular purpose and suitable for user's method of use or application.

3M provides information in electronic form as a service to its customers. Due to the remote possibility that electronic transfer may have resulted in errors, omissions or alterations in this information, 3M makes no representations as to its completeness or accuracy. In addition, information obtained from a database may not be as current as the information in the SDS available directly from 3M

3M USA SDSs are available at www.3M.com

1.8.3 Galden® HT200

SAFETY DATA SHEET

GALDEN® HT200

Revision Date 2015-09-29

SECTION 1: Identification of the substance/mixture and of the company/undertaking**1.1 Product identifier**

- Trade name GALDEN® HT200

1.2 Relevant identified uses of the substance or mixture and uses advised against**Uses of the Substance/Mixture**

- Heat transfer medium
- For industrial use only.

1.3 Details of the supplier of the safety data sheet**Company**

SOLVAY SPECIALTY POLYMERS JAPAN K.K.
7TH FL, ATAGO GREEN HILLS MORI TOWER
ATAGO 2-5-1, MINATO-KU
105-6207, TOKYO
JAPAN
Tel: +81-3-54254300 / 4330
Fax: +81-3-54254321

E-mail address

sds.solvay@solvay.com

1.4 Emergency telephone number

+81 345 789 341 [Carechem 24]

SECTION 2: Hazards identification**2.1 Classification of the substance or mixture****Classification (JIS Z 7252) and Hazard communication (JIS Z 7253) based on GHS.**

- Not classified as hazardous product according to JIS Z 7252.

2.2 Label elements**Classification (JIS Z 7252) and Hazard communication (JIS Z 7253) based on GHS.**

- No GHS labelling required according to JIS Z 7253.

2.3 Other hazards which do not result in classification

- Thermal decomposition can lead to release of toxic and corrosive gases.

SECTION 3: Composition/information on ingredients**3.1 Substance**

- Chemical nature Perfluorinated polyethers

P01000018311
Version : 1.09 / JP (EN)
www.solvay.com

1 / 12



SAFETY DATA SHEET

GALDEN® HT200

Revision Date 2015-09-29

Information on Components and Impurities

Chemical Name	CAS-No.	Number on official gazette	Concentration [%]
Perfluorinated polyether	*****	*****	> 99.9

3.2 Mixture

- Not applicable, this product is a substance.

SECTION 4: First aid measures

4.1 Description of first aid measures

In case of inhalation

- Move to fresh air in case of accidental inhalation of fumes from overheating or combustion.
- Oxygen or artificial respiration if needed.

In case of skin contact

- Wash off with soap and water.

In case of eye contact

- Rinse immediately with plenty of water, also under the eyelids, for at least 15 minutes.
- If eye irritation persists, consult a specialist.

In case of ingestion

- Drink 1 or 2 glasses of water.
- Do NOT induce vomiting.
- If symptoms persist, call a physician.

4.2 Most important symptoms and effects, both acute and delayed

In case of inhalation

Effects

- No known effect.

In case of skin contact

Effects

- Effects of skin contacts may include:
- Redness

In case of eye contact

Effects

- Contact with eyes may cause irritation.
- Redness

In case of ingestion

Symptoms

- Ingestion may provoke the following symptoms:
- Nausea
- Vomiting
- Diarrhoea

4.3 Indication of any immediate medical attention and special treatment needed

Notes to physician

- None

P01000018311
Version : 1.09 / JP (EN)
www.solvay.com



2 / 12

SAFETY DATA SHEET

GALDEN® HT200

Revision Date 2015-09-29

SECTION 5: Firefighting measures**5.1 Extinguishing media****Suitable extinguishing media**

- Water
- powder
- Foam
- Dry chemical
- Carbon dioxide (CO₂)

Unsuitable extinguishing media

- None

5.2 Special hazards arising from the substance or mixture

- The product is not flammable.
- Not explosive
- In case of fire hazardous decomposition products may be produced such as: Gaseous hydrogen fluoride (HF), Fluorophosgene

5.3 Advice for firefighters**Special protective equipment for firefighters**

- Wear self-contained breathing apparatus and protective suit.
- When intervention in close proximity wear acid resistant over suit.

Further information

- Evacuate personnel to safe areas.
- Approach from upwind.
- Protect intervention team with a water spray as they approach the fire.
- Keep containers and surroundings cool with water spray.
- Keep product and empty container away from heat and sources of ignition.

SECTION 6: Accidental release measures**6.1 Personal precautions, protective equipment and emergency procedures****Advice for non-emergency personnel**

- Prevent further leakage or spillage if safe to do so.

Advice for emergency responders

- Ensure adequate ventilation.
- Material can create slippery conditions.
- Sweep up to prevent slipping hazard.
- Keep away from open flames, hot surfaces and sources of ignition.

6.2 Environmental precautions

- Should not be released into the environment.
- Do not flush into surface water or sanitary sewer system.

6.3 Methods and materials for containment and cleaning up

- Soak up with inert absorbent material.
- Suitable material for picking up.
- Dry sand
- Earth
- Shovel into suitable container for disposal.

6.4 Reference to other sections

P01000018311
Version : 1.09 / JP (EN)

www.solvay.com

3 / 12



SAFETY DATA SHEET

GALDEN® HT200

Revision Date 2015-09-29

- Refer to protective measures listed in sections 7 and 8.

SECTION 7: Handling and storage

7.1 Precautions for safe handling

- Ensure adequate ventilation.
- Use personal protective equipment.
- Keep away from heat and sources of ignition.
- To avoid thermal decomposition, do not overheat.
- Take measures to prevent the build up of electrostatic charge.
- Clean and dry piping circuits and equipment before any operations.
- Ensure all equipment is electrically grounded before beginning transfer operations.

Hygiene measures

- Ensure that eyewash stations and safety showers are close to the workstation location.
- When using do not eat, drink or smoke.
- Wash hands before breaks and at the end of workday.
- Handle in accordance with good industrial hygiene and safety practice.

7.2 Conditions for safe storage, including any incompatibilities

Technical measures/Storage conditions

- Keep away from heat and sources of ignition.
- Keep in properly labelled containers.
- Keep away from combustible material.
- Keep away from incompatible products
- Provide tight electrical equipment well protected against corrosion.
- Refer to protective measures listed in sections 7 and 8.

Packaging material

Suitable material

- polyethylene containers

7.3 Specific end use(s)

- Contact your supplier for additional information

SECTION 8: Exposure controls/personal protection

8.1 Control parameters

- We are not aware of any national exposure limit.

P01000018311
Version : 1.09 / JP (EN)
www.solvay.com

4 / 12



SAFETY DATA SHEET

GALDEN® HT200

Revision Date 2015-09-29

Threshold limit values of by-products from thermal decomposition:**Components with official national occupational exposure limits**

Components	Value type	Value	Basis
hydrogen fluoride	ACL	0.5 ppm	Japan. Administrative Control Levels

Components with other national occupational exposure limits

Components	Value type	Value	Basis
hydrogen fluoride	OEL-C	3 ppm 2.5 mg/m3	Japan. The Japan Society for Occupational Health. Recommendation of Occupational Exposure Limits

Components with other occupational exposure limits

Components	Value type	Value	Basis
hydrogen fluoride	TWA	0.5 ppm	USA. ACGIH Threshold Limit Values (TLV)
		Danger of cutaneous absorption Expressed as :Fluorine	
hydrogen fluoride	C	2 ppm	USA. ACGIH Threshold Limit Values (TLV)
		Danger of cutaneous absorption Expressed as :Fluorine	
carbonyl difluoride	TWA	2 ppm	USA. ACGIH Threshold Limit Values (TLV)
carbonyl difluoride	STEL	5 ppm	USA. ACGIH Threshold Limit Values (TLV)

Biological Exposure Indices

Components	Value type	Value	Basis
hydrogen fluoride	BEI	2 mg/l Fluoride Urine Prior to shift (16 hours after exposure ceases)	ACGIH - Biological Exposure Indices (BEI)
hydrogen fluoride	BEI	3 mg/l Fluoride Urine End of shift (As soon as possible after exposure ceases)	ACGIH - Biological Exposure Indices (BEI)

P01000018311
Version : 1.09 / JP (EN)
www.solvay.com

5 / 12



SAFETY DATA SHEET

GALDEN® HT200

Revision Date 2015-09-29

8.2 Exposure controls

Control measures

Engineering measures

- Provide local ventilation appropriate to the product decomposition risk (see section 10).
- Refer to protective measures listed in sections 7 and 8.
- Apply technical measures to comply with the occupational exposure limits.

Individual protection measures

Respiratory protection

- In case of decomposition (see section 10), use an air breathing apparatus with face mask.
- Use only respiratory protection that conforms to international/ national standards.

Hand protection

- Wear protective gloves.

Suitable material

- Nitrile rubber
- PVC
- Neoprene gloves
- butyl-rubber

- Take note of the information given by the producer concerning permeability and break through times, and of special workplace conditions (mechanical strain, duration of contact).

Eye protection

- Tightly fitting safety goggles

Skin and body protection

- Wear work overall and safety shoes.

Hygiene measures

- Ensure that eyewash stations and safety showers are close to the workstation location.
- When using do not eat, drink or smoke.
- Wash hands before breaks and at the end of workday.
- Handle in accordance with good industrial hygiene and safety practice.

Environmental exposure controls

- Dispose of rinse water in accordance with local and national regulations.

SECTION 9: Physical and chemical properties

9.1 Information on basic physical and chemical properties

Appearance	Physical state: liquid
	Colour: colourless
Odour	odourless
Odour Threshold	no data available
pH	no data available
Melting point/range	Not applicable
Boiling point/boiling range	200 °C
Flash point	The product is not flammable.
Evaporation rate (Butylacetate = 1)	no data available
Flammability (liquids)	The product is not flammable.
Flammability/Explosive limit	no data available

P01000018311
Version : 1.09 / JP (EN)
www.solvay.com

6 / 12



SAFETY DATA SHEET

GALDEN® HT200

Revision Date 2015-09-29

<u>Auto-ignition temperature</u>	no data available
<u>Vapour pressure</u>	0.27 hPa
<u>Vapour density</u>	no data available
<u>Density</u>	1.79 g/cm ³
<u>Solubility</u>	<u>Water solubility</u> : insoluble
	<u>Solubility in other solvents</u> : Fluorinated solvents : soluble
<u>Partition coefficient: n-octanol/water</u>	no data available
<u>Thermal decomposition</u>	> 290 °C
<u>Viscosity</u>	<u>Viscosity, dynamic</u> : ca. 4.3 mPa.s
<u>Explosive properties</u>	Not explosive
<u>Oxidizing properties</u>	Not considered as oxidizing

9.2 Other information

<u>Molecular weight</u>	870 Da Polymer Molar Mass
-------------------------	------------------------------

SECTION 10: Stability and reactivity

10.1 Reactivity

- No dangerous reaction known under conditions of normal use.

10.2 Chemical stability

- Stable under recommended storage conditions.
- Metals promote and lower decomposition temperature

10.3 Possibility of hazardous reactions

- No dangerous reaction known under conditions of normal use.

10.4 Conditions to avoid

- Avoid to use in presence of high voltage electric arc and in absence of oxygen.
- Keep away from flames.
- To avoid thermal decomposition, do not overheat.

10.5 Incompatible materials

- Alkali metals
- Lewis acids (Friedel-Crafts) above 100°C
- Aluminum and magnesium in powder form above 200°C

10.6 Hazardous decomposition products

- Gaseous hydrogen fluoride (HF).
- Fluorophosgene

P01000018311
Version : 1.09 / JP (EN)
www.solvay.com

7 / 12



SAFETY DATA SHEET

GALDEN® HT200

Revision Date 2015-09-29

SECTION 11: Toxicological information

11.1 Information on toxicological effects

Acute toxicity

Acute oral toxicity

LD50 : > 15,000 mg/kg - Rat , male and female
Method: OECD Test Guideline 401
Test substance: Molecular weight ~ 650
Not classified as hazardous for acute oral toxicity according to GHS.
No effect observed at this dose or concentration

Acute inhalation toxicity

LC50 - 4 h (vapour) : > 66.6 mg/l - Rat , male and female
Method: OECD Test Guideline 403
Test substance: Molecular weight ~ 650
Not classified as hazardous for acute inhalation toxicity according to GHS.
no observed effect

Acute dermal toxicity

LD50 : > 5,000 mg/kg - Rat , male and female
Method: OECD Test Guideline 402
Test substance: Molecular weight ~ 650
Not classified as hazardous for acute dermal toxicity according to GHS.
No effect observed at this dose or concentration
no data available

Acute toxicity (other routes of administration)

no data available

Skin corrosion/irritation

Rabbit
Not classified as irritating to skin
Method: OECD Test Guideline 404
Test substance: Molecular weight ~ 650
2 Weeks - Rabbit
No skin irritation
Method: Repeated dermal application test.
Test substance: Molecular weight ~ 650

Serious eye damage/eye irritation

Rabbit
Not classified as irritating to eyes
Method: OECD Test Guideline 405
Test substance: Molecular weight ~ 650
Unpublished internal reports

Respiratory or skin sensitisation

Buehler Test - Guinea pig
Does not cause skin sensitisation.
Method: OECD Test Guideline 406
Test substance: Molecular weight ~ 650
Unpublished internal reports

P01000018311
Version : 1.09 / JP (EN)

www.solvay.com

8 / 12



SAFETY DATA SHEET

GALDEN® HT200

Revision Date 2015-09-29

Mutagenicity**Genotoxicity in vitro**Ames test
with and without metabolic activationnegative
Method: OECD Test Guideline 471
Test substance: Molecular weight ~ 650
Chromosome aberration test in vitro
with and without metabolic activationnegative
Method: OECD Test Guideline 473
Test substance: Molecular weight ~ 650**Genotoxicity in vivo**In vivo micronucleus test - Rat
male
Oral
Method: OECD Test Guideline 474
Test substance: Molecular weight ~ 650

negative

Carcinogenicity

no data available

Toxicity for reproduction and development**Toxicity to reproduction/Fertility** no data available
Developmental Toxicity/Teratogenicity no data available**STOT****STOT - single exposure**

The substance or mixture is not classified as specific target organ toxicant, single exposure according to GHS criteria.

STOT - repeated exposure

no data available

CMR effects**Mutagenicity**

The product is considered to be non-mutagenic based on an overall assessment of the data from animal and/or in vitro testing.

Aspiration toxicity

no data available

Further informationDescription of possible hazardous to health effects is based on experience and/or toxicological characteristics of several components.
Thermal decomposition can lead to release of toxic and corrosive gases.
The exposure to decomposition products causes severe irritation of eyes, skin and mucous membranes.

SAFETY DATA SHEET

GALDEN® HT200

Revision Date 2015-09-29

SECTION 12: Ecological information

12.1 Toxicity

Aquatic Compartment

Acute toxicity to fish

By analogy
No toxicity at the limit of solubility

Acute toxicity to daphnia and other aquatic invertebrates.

By analogy
No toxicity at the limit of solubility

12.2 Persistence and degradability

Degradability assessment

The product is not considered to be rapidly degradable in the environment

12.3 Bioaccumulative potential

no data available

12.4 Mobility in soil

no data available

12.5 Results of PBT and vPvB assessment

no data available

12.6 Other adverse effects

no data available

Ecotoxicity assessment

Acute aquatic toxicity

No toxicity at the limit of solubility

Remarks

Ecological injuries are not known or expected under normal use.

SECTION 13: Disposal considerations

13.1 Waste treatment methods

Product Disposal

- Can be incinerated, when in compliance with local regulations.
- The incinerator must be equipped with a system for the neutralisation or recovery of HF.
- Dispose of in accordance with local regulations.

Advice on cleaning and disposal of packaging

- Empty containers can be landfilled, when in accordance with the local regulations.

SECTION 14: Transport information

Local regulation

not regulated

International transport regulations

P01000018311
Version : 1.09 / JP (EN)

www.solvay.com

10 / 12



SAFETY DATA SHEET

GALDEN® HT200

Revision Date 2015-09-29

IMDG

not regulated

IATA

not regulated

Note: The above regulatory prescriptions are those valid on the date of publication of this sheet. Given the possible evolution of transport regulations for hazardous materials, it would be advisable to check their validity with your sales office.

SECTION 15: Regulatory information**15.1 Safety, health and environmental regulations/legislation specific for the substance or mixture**

ISHL Substances Subject to be Notified Names Not relevant

Poisonous and Deleterious Substances Control Law Not relevant

Act on Confirmation, etc. of Release Amounts of Specific Chemical Substances in the Environment and Promotion of Improvements to the Management Thereof Not relevant

Notification status

Inventory Information	Status
United States TSCA Inventory	- Listed on Inventory
Canadian Domestic Substances List (DSL)	- Listed on Inventory
Australia Inventory of Chemical Substances (AICS)	- Listed on Inventory
Korea. Korean Existing Chemicals Inventory (KECI)	- Listed on Inventory
China. Inventory of Existing Chemical Substances in China (IECSC)	- Listed on Inventory
Japan. ISHL - Inventory of Chemical Substances	- Listed on Inventory
Japan. CSCL - Inventory of Existing and New Chemical Substances	- Listed on Inventory
Philippines Inventory of Chemicals and Chemical Substances (PICCS)	- Listed on Inventory
New Zealand. Inventory of Chemical Substances	- Listed on Inventory
Taiwan. Chemical Substance Inventory (TCSI)	- Listed on Inventory
EU. European Registration, Evaluation, Authorisation and Restriction of Chemical (REACH)	- If product is purchased from Solvay in Europe it is in compliance with REACH, if not please contact the supplier.

SECTION 16: Other information

P01000018311
Version : 1.09 / JP (EN)
www.solvay.com

11 / 12



SAFETY DATA SHEET

GALDEN® HT200

Revision Date 2015-09-29

Key or legend to abbreviations and acronyms used in the safety data sheet

- | | |
|---------|-------------------------------------|
| - ACL | Administrative Control level |
| - C | Ceiling limit |
| - OEL-C | Occupational Exposure Limit-Ceiling |
| - STEL | Short-term exposure limit |
| - TWA | 8-hour, time-weighted average |

The information provided in this Safety Data Sheet is correct to the best of our knowledge, information and belief at the date of its publication. Such information is only given as a guidance to help the user handle, use, process, store, transport, dispose and release the product in satisfactory safety conditions and is not to be considered as a warranty or quality specification. It should be used in conjunction with technical sheets but do not replace them. Thus, the information only relates to the designated specific product and may not be applicable if such product is used in combination with other materials or in any other manufacturing process, unless otherwise specifically indicated. It does not release the user from ensuring he is in conformity with all regulations linked to its activity.

P01000018311
Version : 1.09 / JP (EN)
www.solvay.com

12 / 12



1.8.4 Fluorinert™ FC-40

3M™ Fluorinert™ Electronic Liquid FC-40 09/16/16
--



Safety Data Sheet

Copyright, 2016, 3M Company.

All rights reserved. Copying and/or downloading of this information for the purpose of properly utilizing 3M products is allowed provided that: (1) the information is copied in full with no changes unless prior written agreement is obtained from 3M, and (2) neither the copy nor the original is resold or otherwise distributed with the intention of earning a profit thereon.

Document Group:	10-3783-7	Version Number:	55.00
Issue Date:	09/16/16	Supersedes Date:	09/06/16

SECTION 1: Identification

1.1. Product identifier

3M™ Fluorinert™ Electronic Liquid FC-40

Product Identification Numbers

98-0204-0901-1, 98-0212-4881-4, 98-0212-4907-7

1.2. Recommended use and restrictions on use

Recommended use

For industrial use only. Not intended for use as a medical device or drug. Not for sale in Japan.

Restrictions on use

Fluorinert™ Electronic Liquids are used in a wide variety of applications, including but not limited to precision cleaning of medical devices and as lubricant deposition solvents for medical devices. When the product is used for applications where the finished device is implanted into the human body, no residual Fluorinert solvent may remain on the parts. It is highly recommended that the supporting test results and protocol be cited during FDA registration.

3M Electronics Markets Materials Division (EMMD) will not knowingly sample, support, or sell its products for incorporation in medical and pharmaceutical products and applications in which the 3M product will be temporarily or permanently implanted into humans or animals. The customer is responsible for evaluating and determining that a 3M EMMD product is suitable and appropriate for its particular use and intended application. The conditions of evaluation, selection, and use of a 3M product can vary widely and affect the use and intended application of a 3M product. Because many of these conditions are uniquely within the user's knowledge and control, it is essential that the user evaluate and determine whether the 3M product is suitable and appropriate for a particular use and intended application, and complies with all local applicable laws, regulations, standards, and guidance.

1.3. Supplier's details

MANUFACTURER:	3M
DIVISION:	Electronics Materials Solutions Division
ADDRESS:	3M Center, St. Paul, MN 55144-1000, USA
Telephone:	1-888-3M HELPS (1-888-364-3577)

1.4. Emergency telephone number

1-800-364-3577 or (651) 737-6501 (24 hours)

SECTION 2: Hazard identification

2.1. Hazard classification

3M™ Fluorinert™ Electronic Liquid FC-40 09/16/16

Not classified as hazardous according to OSHA Hazard Communication Standard, 29 CFR 1910.1200.

2.2. Label elements

Signal word
 Not applicable.

Symbols
 Not applicable.

Pictograms
 Not applicable.

2.3. Hazards not otherwise classified
 None.

SECTION 3: Composition/information on ingredients

Ingredient	C.A.S. No.	% by Wt
PERFLUORO COMPOUNDS, C5-18	86508-42-1	100

SECTION 4: First aid measures

4.1. Description of first aid measures

Inhalation:
 No need for first aid is anticipated.

Skin Contact:
 Wash with soap and water. If signs/symptoms develop, get medical attention.

Eye Contact:
 Flush with large amounts of water. Remove contact lenses if easy to do. Continue rinsing. If signs/symptoms persist, get medical attention.

If Swallowed:
 No need for first aid is anticipated.

4.2. Most important symptoms and effects, both acute and delayed
 See Section 11.1. Information on toxicological effects.

4.3. Indication of any immediate medical attention and special treatment required
 Not applicable

SECTION 5: Fire-fighting measures

5.1. Suitable extinguishing media
 Non-combustible. Use a fire fighting agent suitable for surrounding fire.

5.2. Special hazards arising from the substance or mixture
 Exposure to extreme heat can give rise to thermal decomposition.

Hazardous Decomposition or By-Products

<u>Substance</u>	<u>Condition</u>
Carbon monoxide	During Combustion

3M™ Fluorinert™ Electronic Liquid FC-40 09/16/16
--

Carbon dioxide

During Combustion

5.3. Special protective actions for fire-fighters

When fire fighting conditions are severe and total thermal decomposition of the product is possible, wear full protective clothing, including helmet, self-contained, positive pressure or pressure demand breathing apparatus, bunker coat and pants, bands around arms, waist and legs, face mask, and protective covering for exposed areas of the head.

SECTION 6: Accidental release measures**6.1. Personal precautions, protective equipment and emergency procedures**

Ventilate the area with fresh air. For large spill, or spills in confined spaces, provide mechanical ventilation to disperse or exhaust vapors, in accordance with good industrial hygiene practice.

6.2. Environmental precautions

Avoid release to the environment. For larger spills, cover drains and build dikes to prevent entry into sewer systems or bodies of water.

6.3. Methods and material for containment and cleaning up

Contain spill. Working from around the edges of the spill inward, cover with bentonite, vermiculite, or commercially available inorganic absorbent material. Mix in sufficient absorbent until it appears dry. Collect as much of the spilled material as possible. Place in a closed container approved for transportation by appropriate authorities. Clean up residue with an appropriate solvent selected by a qualified and authorized person. Ventilate the area with fresh air. Read and follow safety precautions on the solvent label and SDS. Seal the container. Dispose of collected material as soon as possible.

SECTION 7: Handling and storage**7.1. Precautions for safe handling**

Do not breathe thermal decomposition products. Avoid skin contact with hot material. For industrial or professional use only. Store work clothes separately from other clothing, food and tobacco products. No smoking: Smoking while using this product can result in contamination of the tobacco and/or smoke and lead to the formation of hazardous decomposition products.

7.2. Conditions for safe storage including any incompatibilities

Store away from heat.

SECTION 8: Exposure controls/personal protection**8.1. Control parameters****Occupational exposure limits**

No occupational exposure limit values exist for any of the components listed in Section 3 of this SDS.

8.2. Exposure controls**8.2.1. Engineering controls**

Provide appropriate local exhaust when product is heated.

8.2.2. Personal protective equipment (PPE)**Eye/face protection**

None required.

Skin/hand protection

3M™ Fluorinert™ Electronic Liquid FC-40 09/16/16

No chemical protective gloves are required.

Respiratory protection

Use a positive pressure supplied-air respirator if there is a potential for over exposure from an uncontrolled release, exposure levels are not known, or under any other circumstances where air-purifying respirators may not provide adequate protection. During heating:

Use a positive pressure supplied-air respirator if there is a potential for over exposure from an uncontrolled release, exposure levels are not known, or under any other circumstances where air-purifying respirators may not provide adequate protection.

Thermal hazards

Wear heat insulating gloves when handling hot material to prevent thermal burns.

SECTION 9: Physical and chemical properties

9.1. Information on basic physical and chemical properties

General Physical Form:	Liquid
Specific Physical Form:	Liquid
Odor, Color, Grade:	Colorless, odorless liquid.
Odor threshold	<i>No Data Available</i>
pH	<i>Not Applicable</i>
Melting point	<i>Not Applicable</i>
Boiling Point	158 - 173 °C
Flash Point	No flash point
Evaporation rate	< 1 [<i>Ref Std: BUOAC=1</i>]
Flammability (solid, gas)	Not Applicable
Flammable Limits(LEL)	None detected
Flammable Limits(UEL)	None detected
Vapor Pressure	3 mmHg [<i>@ 25 °C</i>]
Vapor Density	22.5 [<i>@ 25 °C</i>] [<i>Ref Std: AIR=1</i>]
Density	1.9 g/ml
Specific Gravity	1.9 [<i>Ref Std: WATER=1</i>]
Solubility in Water	Nil
Solubility- non-water	<i>No Data Available</i>
Partition coefficient: n-octanol/ water	<i>No Data Available</i>
Autoignition temperature	<i>No Data Available</i>
Decomposition temperature	<i>No Data Available</i>
Viscosity	2 centistoke [<i>@ 25 °C</i>]
Molecular weight	<i>No Data Available</i>
Volatile Organic Compounds	[<i>Details: Exempt</i>]
Percent volatile	100 %
VOC Less H2O & Exempt Solvents	[<i>Details: Exempt</i>]

SECTION 10: Stability and reactivity

10.1. Reactivity

This material may be reactive with certain agents under certain conditions - see the remaining headings in this section.

10.2. Chemical stability

Stable.

10.3. Possibility of hazardous reactions

Hazardous polymerization will not occur.

3M™ Fluorinert™ Electronic Liquid FC-40 09/16/16

10.4. Conditions to avoid
Heat

10.5. Incompatible materials
Finely divided active metals
Alkali and alkaline earth metals

10.6. Hazardous decomposition products

<u>Substance</u>	<u>Condition</u>
Hydrogen Fluoride	At Elevated Temperatures - greater than 200 °C
Perfluoroisobutylene (PFIB)	At Elevated Temperatures - greater than 200 °C

Refer to section 5.2 for hazardous decomposition products during combustion.

If the product is exposed to extreme condition of heat from misuse or equipment failure, toxic decomposition products that include hydrogen fluoride and perfluoroisobutylene can occur.

SECTION 11: Toxicological information

The information below may not be consistent with the material classification in Section 2 if specific ingredient classifications are mandated by a competent authority. In addition, toxicological data on ingredients may not be reflected in the material classification and/or the signs and symptoms of exposure, because an ingredient may be present below the threshold for labeling, an ingredient may not be available for exposure, or the data may not be relevant to the material as a whole.

11.1. Information on Toxicological effects

Signs and Symptoms of Exposure

Based on test data and/or information on the components, this material may produce the following health effects:

Inhalation:
No health effects are expected.

Skin Contact:
Contact with the skin during product use is not expected to result in significant irritation.

Eye Contact:
Contact with the eyes during product use is not expected to result in significant irritation.

Ingestion:
No known health effects.

Toxicological Data

If a component is disclosed in section 3 but does not appear in a table below, either no data are available for that endpoint or the data are not sufficient for classification.

Acute Toxicity

Name	Route	Species	Value
PERFLUORO COMPOUNDS, C5-18	Dermal		LD50 estimated to be > 5,000 mg/kg
PERFLUORO COMPOUNDS, C5-18	Inhalation-Vapor (4 hours)	Rat	LC50 > 41 mg/l
PERFLUORO COMPOUNDS, C5-18	Ingestion	Rat	LD50 > 5,000 mg/kg

3M™ Fluorinert™ Electronic Liquid FC-40 09/16/16

ATE = acute toxicity estimate

Skin Corrosion/Irritation

Name	Species	Value
PERFLUORO COMPOUNDS, C5-18	Rabbit	No significant irritation

Serious Eye Damage/Irritation

Name	Species	Value
PERFLUORO COMPOUNDS, C5-18	Rabbit	No significant irritation

Skin Sensitization

For the component/components, either no data are currently available or the data are not sufficient for classification.

Respiratory Sensitization

For the component/components, either no data are currently available or the data are not sufficient for classification.

Germ Cell Mutagenicity

Name	Route	Value
PERFLUORO COMPOUNDS, C5-18	In Vitro	Not mutagenic

Carcinogenicity

For the component/components, either no data are currently available or the data are not sufficient for classification.

Reproductive Toxicity

Reproductive and/or Developmental Effects

For the component/components, either no data are currently available or the data are not sufficient for classification.

Target Organ(s)

Specific Target Organ Toxicity - single exposure

For the component/components, either no data are currently available or the data are not sufficient for classification.

Specific Target Organ Toxicity - repeated exposure

Name	Route	Target Organ(s)	Value	Species	Test Result	Exposure Duration
PERFLUORO COMPOUNDS, C5-18	Inhalation	heart endocrine system bone, teeth, nails, and/or hair hematopoietic system liver immune system nervous system eyes kidney and/or bladder respiratory system	All data are negative	Rat	NOAEL 49,821 ppm	13 weeks
PERFLUORO COMPOUNDS, C5-18	Ingestion	heart endocrine system hematopoietic system liver nervous system kidney and/or bladder respiratory system	All data are negative	Rat	NOAEL 2,000 mg/kg/day	28 days

Aspiration Hazard

For the component/components, either no data are currently available or the data are not sufficient for classification.

3M™ Fluorinert™ Electronic Liquid FC-40 09/16/16

Please contact the address or phone number listed on the first page of the SDS for additional toxicological information on this material and/or its components.

SECTION 12: Ecological information

Ecotoxicological information

Please contact the address or phone number listed on the first page of the SDS for additional ecotoxicological information on this material and/or its components.

Chemical fate information

Please contact the address or phone number listed on the first page of the SDS for additional chemical fate information on this material and/or its components.

SECTION 13: Disposal considerations

13.1. Disposal methods

Dispose of contents/ container in accordance with the local/regional/national/international regulations.

Dispose of waste product in a permitted industrial waste facility. Combustion products will include HF. Facility must be capable of handling halogenated materials.

Empty and clean product containers may be disposed as non-hazardous waste. Consult your specific regulations and service providers to determine available options and requirements.

EPA Hazardous Waste Number (RCRA): Not regulated

SECTION 14: Transport Information

For Transport Information, please visit <http://3M.com/Transportinfo> or call 1-800-364-3577 or 651-737-6501.

SECTION 15: Regulatory information

15.1. US Federal Regulations

Contact 3M for more information.

311/312 Hazard Categories:

Fire Hazard - No Pressure Hazard - Yes Reactivity Hazard - No Immediate Hazard - No Delayed Hazard - No

15.2. State Regulations

Contact 3M for more information.

15.3. Chemical Inventories

The components of this material are in compliance with the provisions of Australia National Industrial Chemical Notification and Assessment Scheme (NICNAS). Certain restrictions may apply. Contact the selling division for additional information.

The components of this product are in compliance with the new substance notification requirements of CEPA.

The components of this material are in compliance with the China "Measures on Environmental Management of New Chemical Substance". Certain restrictions may apply. Contact the selling division for additional information.

The components of this material are in compliance with the provisions of the Korean Toxic Chemical Control Law. Certain

3M™ Fluorinert™ Electronic Liquid FC-40 09/16/16

restrictions may apply. Contact the selling division for additional information.

The components of this material are in compliance with the provisions of Philippines RA 6969 requirements. Certain restrictions may apply. Contact the selling division for additional information.

The components of this product are in compliance with the chemical notification requirements of TSCA.

Contact 3M for more information.

15.4. International Regulations

Contact 3M for more information.

This SDS has been prepared to meet the U.S. OSHA Hazard Communication Standard, 29 CFR 1910.1200.

SECTION 16: Other information

NFPA Hazard Classification

Health: 3 Flammability: 0 Instability: 0 Special Hazards: None

National Fire Protection Association (NFPA) hazard ratings are designed for use by emergency response personnel to address the hazards that are presented by short-term, acute exposure to a material under conditions of fire, spill, or similar emergencies. Hazard ratings are primarily based on the inherent physical and toxic properties of the material but also include the toxic properties of combustion or decomposition products that are known to be generated in significant quantities.

HMIS Hazard Classification

Health: 0 Flammability: 0 Physical Hazard: 0 Personal Protection: X - See PPE section.

Hazardous Material Identification System (HMIS® IV) hazard ratings are designed to inform employees of chemical hazards in the workplace. These ratings are based on the inherent properties of the material under expected conditions of normal use and are not intended for use in emergency situations. HMIS® IV ratings are to be used with a fully implemented HMIS® IV program. HMIS® is a registered mark of the American Coatings Association (ACA).

Document Group:	10-3783-7	Version Number:	55.00
Issue Date:	09/16/16	Supersedes Date:	09/06/16

DISCLAIMER: The information in this Safety Data Sheet (SDS) is believed to be correct as of the date issued. 3M MAKES NO WARRANTIES, EXPRESSED OR IMPLIED, INCLUDING, BUT NOT LIMITED TO, ANY IMPLIED WARRANTY OF MERCHANTABILITY OR FITNESS FOR A PARTICULAR PURPOSE OR COURSE OF PERFORMANCE OR USAGE OF TRADE. User is responsible for determining whether the 3M product is fit for a particular purpose and suitable for user's method of use or application. Given the variety of factors that can affect the use and application of a 3M product, some of which are uniquely within the user's knowledge and control, it is essential that the user evaluate the 3M product to determine whether it is fit for a particular purpose and suitable for user's method of use or application.

3M provides information in electronic form as a service to its customers. Due to the remote possibility that electronic transfer may have resulted in errors, omissions or alterations in this information, 3M makes no representations as to its completeness or accuracy. In addition, information obtained from a database may not be as current as the information in the SDS available directly from 3M

3M USA SDSs are available at www.3M.com

1.8.5 Ethylene glycol aqueous solution 60%

ETHYLENE GLYCOL, 60% Aqueous Solution 1/6

SAFETY DATA SHEET

INITIAL DATE	13 Oct. 2006
REVISION DATE	17 Sep. 2015
REVISION No.	4

SECTION 1 : [CHEMICAL PRODUCT AND COMPANY IDENTIFICATION]

SDS No. : SWB-0990-08E
 PRODUCT NAME : ETHYLENE GLYCOL, 60% Aqueous Solution
 PRODUCT NUMBER : HRZ-BR001
 MANUFACTURER : SHOWA WATER INDUSTRIES CO. LTD.
 ADDRESS : 764 Washinosu, Yorocho, Yorogun, Gifu, 503-1261 JAPAN
 DEPT. IN CHARGE : QUALITY ASSURANCE DEPARTMENT
 TELEPHONE : 81-584-32-3105
 FAX : 81-584-32-3107

SECTION 2 : [HAZARDS IDENTIFICATION]

MOST IMPORTANT HAZARDS :

HEALTH HAZARDS ; Harmful if swallowed. The product is irritating to the eyes and respiratory tract.
 The product may cause effects on the kidneys and central nervous system. This may result in renal failure and brain injury. Exposure could cause lowering of consciousness.

ENVIRONMENTAL EFFECTS ; Harmful to aquatic organisms.

PHYSICAL & CHEMICAL DANGERS ; Non-flammable.

SPECIAL HAZARDS : Causes damage to organs. Causes mild skin irritation and eye irritation.

OVERVIEW OF EMERGENCY EXPECTED : Gives off irritating or toxic gases on combustion.

GHS CLASSIFICATION :

Serious eye damage / Eye irritation ; Category 2B
 Specific target organ systemic toxicity (Single exposure) ; Category 1 *1)
 Specific target organ systemic toxicity (Repeated exposure) ; Category 1 *2)
 Hazardous to the aquatic environment (acute) ; Category 3

*1) central nervous system, kidney, heart, respiratory organs

*2) central nervous system, heart, respiratory organs

※Classification according to 「Japanese Industrial Standard (JIS Z 7252:2014)」.

※Hazards which are not indicated in above summary are [Not classified], [Not applicable] or [Classification not possible].

GHS LABEL ELEMENTS :

PICTOGRAM ;



SIGNAL WORD ; Danger

HAZARD STATEMENT :

Causes eye irritation.

Causes damage to organs (central nervous system, kidneys, heart, respiratory organs).

Causes damage to organs (central nervous system, heart, respiratory organs) through prolonged or

SHOWA WATER INDUSTRIES CO.,LTD.

repeated exposure.

Harmful to aquatic life.

PRECAUTIONARY STATEMENT :

A SAFETY MEASURE ;

Wash hands thoroughly after handling.

Do not breathe mist/vapours.

Do not eat, drink or smoke when using this product.

Avoid release to the environment.

FIRST-AID MEASURES ;

IF IN EYES : Rinse cautiously with water for several minutes. Remove contact lenses, if present and easy to do. Continue rinsing. If eye irritation persists, get medical advice/attention.

If eye irritation persists, get medical advice/attention.

IF EXPOSED OR CONCERNED : Get medical advice/attention.

Get medical advice/attention if you feel unwell.

STORAGE ;

Keep locked up.

DISPOSAL ;

Dispose of contents/container in accordance with local/regional/national/international regulations.

SECTION 3 : [COMPOSITION / INFORMATION ON INGREDIENTS]

SUBSTANCE OR MIXTURE : Substance

Chemical Name	Concentration (mass%)	CAS No.	MITI No. *3)	EINECS
ETHYLENE GLYCOL	59~61	107-21-1	2-230	203-473-3
WATER	39~41	7732-18-5	—	231-791-2

*3) MITI No. ; Japanese Ministry of International Trade and Industry registration number

SECTION 4 : [FIRST AID MEASURES]

INHALATION : If large amounts of mist/vapours has been inhaled, immediately remove the exposed person to fresh air and keep quiet. Get medical advice/attention if you feel unwell.

SKIN CONTACT : Remove contaminated clothes. Rinse skin with plenty of water and then wash skin with soap. Consult a doctor if there is a change in appearance or if there is pain.

EYE CONTACT : Firstly, rinse with plenty of water for at least 15 minutes (remove contact lenses if easily possible), then refer for medical advice/attention.

INGESTION : Rinse mouth with water and drink plenty of water. Induce vomiting. Immediately take a medical advice/attention. Never give anything by mouth to an unconscious person.

THE EXPECTED ACUTE AND TARDIVE SYMPTON : No information about product.

◆ETHYLENE GLYCOL

Inhalation : Cough. Dizziness. Headache.

Skin : Dry skin.

Eyes : Redness. Pain.

Ingestion : Abdominal pain. Dullness. Nausea. Unconsciousness. Vomiting.

THE MOST IMPORTANT SYMPTOMS AND EFFECTS : No information.

PROTECTION FOR FIRST-AIDS : Use of suitable protective equipment.

SPECIAL NOTES FOR DOCTORS : No information.

SECTION 5 : [FIRE-FIGHTING MEASURES]

SUITABLE EXTINGUISHING MEDIA :

Not flammable. But may cause flammability due to heating.

Water spray, Carbon dioxide, Foam, Dry chemical, Dry sand, etc

UNSUITABLE EXTINGUISHING MEDIA : No information.**SPECIFIC HAZARDS WITH REGARD TO FIRE-FIGHTING :**

This product may give off irritating or toxic gases in a fire.

SPECIFIC METHODS OF FIRE-FIGHTING :

Prohibit the entrance except the person concerned.

Move container from fire area if it can be done without risk.

Keep fire-exposed containers cool by spraying with water.

The fire-fighting should be performed from the windward side, with suitable respiratory protective device, if necessary.

PROTECTION FOR FIREFIGHTERS :

Fighters should wear protective clothing, respirator, rubber boots and fireproof clothing.

SECTION 6 : [ACCIDENTAL RELEASE MEASURES]

PERSONAL PRECAUTIONS / PROTECTIVE EQUIPMENT AND EMERGENCY PROCEDURES :

Rope off the leakage place to prohibit the entry of person.

Wear appropriate personal protective equipments (Refer to section 8) when clean up working, and avoid contact.

Work from the windward side.

In the case of indoor, open the windows/doors and ventilate it enough.

ENVIRONMENTAL PRECAUTIONS :

Take precautions to minimize effect on environment. Particularly ensure that the product is not directly discharged to the ground or to the water drainage gutters, rivers or lakes.

METHODS FOR CLEANING UP :

Collect by absorbing into dry sand, waste or other materials.

In case of large spills, to prevent effluent with sandbags, and recovered as much as possible by using pumps.

Return spilled liquid to a sealable container and move to a safe location.

Wash away with plenty of water.

Dispose of contaminated waste material in accordance with relevant regulations.

PREVENTION OF SECONDARY HAZARDS :

Immediately remove all ignition sources. (No open flames, no sparks and no smoking.)

SECTION 7 : [HANDLING AND STORAGE]

HANDLING :

TECHNICAL MEASURES ; Use personal protective equipments as required. See section 8.

LOCAL EXHAUST VENTILATION / GENERAL VENTILATION ;

Install local exhaust ventilation and general ventilation system. See section 8.

PRECAUTIONS FOR SAFE HANDLING ;

Handle in a well-ventilated place. Reseal container after each use.

Handle it carefully not to be scattered.

Wash hands, face, mouth and eyes thoroughly after handling.

Do not eat, drink, or smoke during work.

EVASION OF THE CONTACT ; Refer to section 10.

STORAGE :

STORAGE CONDITIONS ;

- Protect from sunlight. Store in a well-ventilated place. Keep cool.
- Storage facilities should be built by a fireproof construction.
- Keep away from strong oxidants, strong bases and strong acids.
- Keep out of reach of children and store locked up.

CONTAINER MATERIAL ;

- Keep container tightly closed. Use containers without breakage, corrosion and leakage.

SECTION 8 : [EXPOSURE CONTROLS / PERSONAL PROTECTION]

MANAGEMENT CONCENTRATION : No information.

OCCUPATIONAL EXPOSURE LIMITS : No information.

< Reference value > Ethylene glycol (aerosol only) ; Ceiling 100mg/m³ - ACGIH(2011)

EQUIPMENT MEASURES :

- When handling in the factory, install local exhaust ventilation and general ventilation system.
- Take measures to prevent the build-up of electrostatic charge, and ensuring all facilities are electrically grounded/earthed.
- Install eye washers and safety showers in worksites where the product is handled, and display them clearly.

PROTECTIVE EQUIPMENTS :

- RESPIRATORY PROTECTION : Respiratory protection mask if necessary.
- HAND PROTECTION : Impervious protective gloves.
(Nitrile gloves, Neoprene gloves, etc.)
- EYE PROTECTION : Safety glasses with side-shields, Goggles, Face protection.
- SKIN PROTECTION : Protective clothing, Safety boots, Safety helmets.

HYGIENE MEASURES : Wash hands thoroughly after handling.

Take off contaminated clothing and wash before reuse.

SECTION 9 : [PHYSICAL AND CHEMICAL PROPERTIES]

APPEARANCE : Colorless liquid.

ODOR : Little

pH : 5.5 ~ 7.5

FLASH POINT : None.

DENSITY : 1,070 ~ 1,090 kg/m³ (20°C)

SOLUBILITY (water) : Miscible.

SECTION 10 : [STABILITY AND REACTIVITY]

CHEMICAL STABILITY : Stable at the normal temperature.

POSSIBILITY OF HAZARDOUS REACTIONS :

No dangerous reaction known under conditions of normal use.

CONDITIONS TO AVOID : High temperature and direct sunlight.

MATERIALS TO AVOID : Strong oxidants, strong acids and strong bases.

HAZARDOUS DECOMPOSITION PRODUCTS : May give off irritating or toxic gases on heating.

SECTION 11 : [TOXICOLOGICAL INFORMATION]

◆PRODUCT

No information.

◆ETHYLENE GLYCOL

ACUTE TOXICITY (oral) : Based on the rat LD₅₀ (oral route) of 4,000 ~ 10,200mg/kg.

SKIN CORROSION / IRRITATION :

Based on the description in the report on rabbit and guinea pig skin irritation tests : "mild dermal irritation in rabbits and guinea pigs."

SERIOUS EYE DAMAGE / EYE IRRITATION :

Based on the description in the report on rabbit eye irritation tests : Short term exposure to ethylene glycol (liquid or vapour) causes conjunctival irritation with no permanent damage to the cornea.

SPECIFIC TARGET ORGAN TOXICITY (SINGLE EXPOSURE) :

Based on the human evidence including : "consciousness disorder, convulsions and stupor (after 34 days of accidental ingestion) ; an increase in urea nitrogen, creatinine and uric acid concentrations (blood examination) ; albuminuria, hematuria and nephropathy (urine examination) ; degeneration of convoluted tubules (renal biopsy) ; mild pulmonary congestion." "acute effects are observed in four stages : effects on the central nervous system (after 0.5~12 hours of exposure) ; effects on the heart-lung system (after 12~36 hours of exposure) ; nephropathy in specimens surviving from Stage 1 and 2 (exposure to ethylene glycol) ; degeneration of the central nervous system".

SPECIFIC TARGET ORGAN TOXICITY (REPEATED EXPOSURE) :

Based on human evidence including "loss of consciousness and nystagmus," "mild headache and backache, upper respiratory tract irritation", and the evidence from animal studies including "inflammatory degeneration of the lung and heart".

SECTION 12 : [ECOLOGICAL INFORMATION]

◆PRODUCT

No information.

◆ETHYLENE GLYCOL

ECOTOXICITY : Harmful to aquatic life. Fishes (Rainbow trout) ; 96-hour LC₅₀=47mg/L

PERSISTENCE / DEGRADABILITY : Readily biodegradable.

BIOACCUMULATION : No information.

MOBILITY IN THE SOIL : No information.

HAZARDOUS TO THE OZONE LAYER : Can not be classified because the substance is not listed in the Annex to the Montreal Protocol.

SECTION 13 : [DISPOSAL CONSIDERATIONS]

RESIDUES :

Disposal methods must be in compliance with all regulations.

This product or used the waste must be entrusted with processing in industrial waste disposer.

CONTAMINATED CONTAINER AND PACKAGING :

Discard container after using up the contents.

Dispose of the container in accordance with local/regional/national/international regulations.

SECTION 14 : [TRANSPORT INFORMATION]

UN NO. (NAME AND DESCRIPTION) : Not applicable.

UN HAZARD CLASS : Not applicable.

UN PACK GROUP : Not applicable.

SPECIFIC PRECAUTIONARY TRANSPORT MEASURES AND CONDITIONS :

When transporting, protect from direct sunlight and take on cargo without breakage of container and leakage. Follow all regulations in your country.

ETHYLENE GLYCOL, 60% Aqueous Solution 6/6

SECTION 15 : [REGULATORY INFORMATION]

TSCA : All components listed.

SECTION 16 : [OTHER INFORMATION]

This information is based upon technical information (Japanese Safety Data Sheet) believed to be reliable. But hazard identification and toxicological information are not comprehensive. So be careful enough about handling.

The data on this sheet relates only to the specific product designated herein. Manufacturer assumes no legal responsibility for the use of these data.

SHOWA WATER INDUSTRIES CO.,LTD.

1.8.6 Refrigerant R410A

SAFETY DATA SHEET



Genetron® AZ-20 (R-410A)

00000009881

Version 1.0 0

Issuing date 02/27/2012

Revision Date 02/27/2012

Print Date 01/30/2014

1. IDENTIFICATION OF THE SUBSTANCE/MIXTURE AND OF THE COMPANY/UNDERTAKING

Product information

Trade name	:	Genetron® AZ-20 (R-410A)
Number	:	00000009881
Recommended use of the chemical and restrictions on use	:	Refrigerant
Company	:	Honeywell Japan Inc. New Pier Takeshiba South Tower 20F, 1-16-1 Minato-ku 1050022 Tokyo, 13 JP
For further information, please contact:	:	800-522-8001 +1-973-455-6300 (Monday-Friday, 9:00am-5:00pm)
In case of emergency call	:	Medical: 1-800-498-5701 or +1-651-523-0309 Transportation: 1-800-424-9300 or +1-703-527-3887 In Japan: +(81)-345209637 (24 hours/day, 7 days/week)

2. HAZARDS IDENTIFICATION

Classification of the substance or mixture

Classification of the substance or mixture	:	Gases under pressure, Liquefied gas Specific target organ toxicity - single exposure, Category 3
--	---	---

GHS Label elements, including precautionary statements

Symbol(s)	:	
Signal word	:	Warning
Hazard statements	:	Contains gas under pressure; may explode if heated. May cause drowsiness and dizziness.
Precautionary statements	:	Prevention: Avoid breathing dust/ fume/ gas/ mist/ vapours/ spray. Use only outdoors or in a well-ventilated area. Response: IF INHALED: Remove victim to fresh air and keep at rest in a

1/12

Genetron® AZ-20 (R-410A)

00000009881

Version 1.0 0

Issuing date 02/27/2012

Revision Date 02/27/2012

Print Date 01/30/2014

position comfortable for breathing.
Call a POISON CENTER or doctor/ physician if you feel unwell.

Storage:

Store in a well-ventilated place. Keep container tightly closed.
Store locked up.
Protect from sunlight. Store in a well-ventilated place.

Disposal:

Dispose of contents/ container to an approved waste disposal plant.

Other hazards which do not result in classification : Causes asphyxiation in high concentrations. The victim will not realize that he/she is suffocating.
May cause cardiac arrhythmia.
May cause frostbite.
May irritate skin.
May irritate eyes.

3. COMPOSITION/INFORMATION ON INGREDIENTS

Chemical nature : Substance

Chemical Name	CAS-No.	Concentration
Pentafluoroethane	354-33-6	50.00 %
Pentafluoroethane		
Difluoromethane	75-10-5	50.00 %
Difluoromethane		

4. FIRST AID MEASURES

Inhalation : Move to fresh air.
If breathing is irregular or stopped, administer artificial respiration.
Use oxygen as required, provided a qualified operator is present.
Call a physician.
Do not give drugs from adrenaline-ephedrine group.

Skin contact : After contact with skin, wash immediately with plenty of water.
If there is evidence of frostbite, bathe (do not rub) with lukewarm (not hot) water. If water is not available, cover with a clean, soft cloth or similar covering.
If symptoms persist, call a physician.

Eye contact : Rinse immediately with plenty of water, also under the eyelids, for at least 15 minutes.
In case of frostbite water should be lukewarm, not hot.

2/12

Genetron® AZ-20 (R-410A)**00000009881**

Version 1.0 0

Issuing date 02/27/2012

Revision Date 02/27/2012

Print Date 01/30/2014

- If symptoms persist, call a physician.
- Ingestion : Unlikely route of exposure.
As this product is a gas, refer to the inhalation section.
Do not induce vomiting without medical advice.
Call a physician immediately.
- Notes to physician : Because of the possible disturbances of cardiac rhythm, catecholamine drugs, such as epinephrine, should be used with special caution and only in situations of emergency life support. Treatment of overexposure should be directed at the control of symptoms and the clinical conditions.
Treat frost-bitten areas as needed.

5. FIREFIGHTING MEASURES

- Suitable extinguishing media : The product is not flammable.
Use water spray, alcohol-resistant foam, dry chemical or carbon dioxide.
Use extinguishing measures that are appropriate to local circumstances and the surrounding environment.
- Specific hazards during firefighting : Contents under pressure.
This product is not flammable at ambient temperatures and atmospheric pressure.
However, this material can ignite when mixed with air under pressure and exposed to strong ignition sources.
Container may rupture on heating.
Cool closed containers exposed to fire with water spray.
Do not allow run-off from fire fighting to enter drains or water courses.
Vapours are heavier than air and can cause suffocation by reducing oxygen available for breathing.
In case of fire hazardous decomposition products may be produced such as:
Hydrogen halides
Hydrogen fluoride
Carbon monoxide
Carbon dioxide (CO₂)
Carbonyl halides
- Special protective equipment for firefighters : In the event of fire and/or explosion do not breathe fumes.
Wear self-contained breathing apparatus and protective suit.
No unprotected exposed skin areas.

6. ACCIDENTAL RELEASE MEASURES

- Personal precautions, protective equipment and emergency procedures : Immediately evacuate personnel to safe areas.
Keep people away from and upwind of spill/leak.
Wear personal protective equipment. Unprotected persons

Genetron® AZ-20 (R-410A)

00000009881

Version 1.0 0

Issuing date 02/27/2012

Revision Date 02/27/2012

Print Date 01/30/2014

must be kept away.
Remove all sources of ignition.
Avoid skin contact with leaking liquid (danger of frostbite).
Ventilate the area.
After release, disperses into the air.
Vapours are heavier than air and can cause suffocation by reducing oxygen available for breathing.
Avoid accumulation of vapours in low areas.
Unprotected personnel should not return until air has been tested and determined safe.
Ensure that the oxygen content is $\geq 19.5\%$.

Environmental precautions : Prevent further leakage or spillage if safe to do so.
The product evaporates readily.

Methods and materials for containment and cleaning up : Ventilate the area.

7. HANDLING AND STORAGE

Handling

Precautions for safe handling : Handle with care.
Avoid inhalation of vapour or mist.
Do not get in eyes, on skin, or on clothing.
Wear personal protective equipment.
Use only in well-ventilated areas.
Pressurized container. Protect from sunlight and do not expose to temperatures exceeding 50 °C.
Follow all standard safety precautions for handling and use of compressed gas cylinders.
Use authorized cylinders only.
Protect cylinders from physical damage.
Do not puncture or drop cylinders, expose them to open flame or excessive heat.
Do not pierce or burn, even after use. Do not spray on a naked flame or any incandescent material.
Do not remove screw cap until immediately ready for use.
Always replace cap after use.

Advice on protection against fire and explosion : The product is not flammable.
Can form a combustible mixture with air at pressures above atmospheric pressure.

Storage

Conditions for safe storage, including any incompatibilities : Pressurized container: protect from sunlight and do not expose to temperatures exceeding 50 °C. Do not pierce or burn, even after use.
Keep containers tightly closed in a dry, cool and well-ventilated place.
Storage rooms must be properly ventilated.
Ensure adequate ventilation, especially in confined areas.

Genetron® AZ-20 (R-410A)

00000009881

Version 1.0 0 Issuing date 02/27/2012 Revision Date 02/27/2012 Print Date 01/30/2014

Protect cylinders from physical damage.
Store away from incompatible substances.

Advice on common storage :

8. EXPOSURE CONTROLS/PERSONAL PROTECTION

Components with workplace control parameters—

Components	CAS-No.	Value	Control parameters	Update	Basis
Difluoromethane Difluoromethane	75-10-5	TWA : time weighted average	(1,000 ppm)	1994	Limit established by Honeywell International Inc.
		TWA : time weighted average	2,200 mg/m3 (1,000 ppm)	2007	US. Workplace Environmental Exposure Level (WEEL) Guides
Pentafluoroethane Pentafluoroethane	354-33-6	TWA : time weighted average	(1,000 ppm)		Limit established by Honeywell International Inc.
		TWA : time weighted average	4,900 mg/m3 (1,000 ppm)	2007	US. Workplace Environmental Exposure Level (WEEL) Guides

Appropriate engineering controls

General room ventilation is adequate for storage and handling.
Perform filling operations only at stations with exhaust ventilation facilities.

Individual protection measures, such as personal protective equipment

Respiratory protection : In case of insufficient ventilation, wear suitable respiratory equipment.
Wear a positive-pressure supplied-air respirator.
Vapours are heavier than air and can cause suffocation by reducing oxygen available for breathing.
For rescue and maintenance work in storage tanks use self-contained breathing apparatus.

Genetron® AZ-20 (R-410A)

00000009881

Version 1.0 0 Issuing date 02/27/2012 Revision Date 02/27/2012 Print Date 01/30/2014

Hand protection	: Leather gloves In case of contact through splashing: Protective gloves Neoprene gloves Polyvinyl alcohol or nitrile- butyl-rubber gloves
Eye protection	: Wear as appropriate: Safety glasses with side-shields If splashes are likely to occur, wear: Goggles or face shield, giving complete protection to eyes
Skin and body protection	: Avoid skin contact with leaking liquid (danger of frostbite). Wear cold insulating gloves/ face shield/ eye protection.
Hygiene measures	: Handle in accordance with good industrial hygiene and safety practice. Ensure adequate ventilation, especially in confined areas. Avoid contact with skin, eyes and clothing. Remove and wash contaminated clothing before re-use. Keep working clothes separately.
Protective measures	: Do not breathe vapour. Avoid contact with skin, eyes and clothing. Ensure that eyewash stations and safety showers are close to the workstation location.

9. PHYSICAL AND CHEMICAL PROPERTIES

Physical state	: Liquefied gas
Colour	: colourless
Odour	: weak
pH	: Note: neutral
Boiling point/boiling range	: -48.5 °C
Flash point	: Note: not applicable
Evaporation rate	: > 1 Method: Compared to CCl ₄ .
lower flammability limit	: Note: None
upper flammability limit	: Note: None

Genetron® AZ-20 (R-410A)**00000009881**

Version 1.0 0

Issuing date 02/27/2012

Revision Date 02/27/2012

Print Date 01/30/2014

Vapour pressure	:	14,844 hPa at 21.1 °C(70.0 °F)
		33,798 hPa at 54.4 °C(129.9 °F)
Vapour density	:	3 Note: (Air = 1.0)
Density	:	1.08 g/cm ³ at 21.1 °C
Water solubility	:	1.5 g/l
Partition coefficient: n-octanol/water	:	log Pow: 1.48 Test substance: Ethane, pentafluoro- (HFC-125)
		log Pow: 0.21 Test substance: Difluoromethane (HFC-32)
Ignition temperature	:	> 750 °C
Decomposition temperature	:	> 250 °C
Ozone depletion potential (ODP)	:	0

10. STABILITY AND REACTIVITY

Chemical stability	:	Stable under normal conditions. Hazardous polymerisation does not occur. Stable under normal conditions.
Possibility of hazardous reactions	:	Hazardous polymerisation does not occur.
Conditions to avoid	:	Pressurized container. Protect from sunlight and do not expose to temperatures exceeding 50 °C. Decomposes under high temperature. Some risk may be expected of corrosive and toxic decomposition products. Can form a combustible mixture with air at pressures above atmospheric pressure.

Genetron® AZ-20 (R-410A)

000000009881

Version 1.0 0

Issuing date 02/27/2012

Revision Date 02/27/2012

Print Date 01/30/2014

Do not mix with oxygen or air above atmospheric pressure.

Incompatible materials to avoid	: Finely divided aluminium Potassium Calcium Powdered metals Aluminium Magnesium Zinc
Hazardous decomposition products	: In case of fire hazardous decomposition products may be produced such as: Hydrogen fluoride Carbonyl halides Carbon monoxide Carbon dioxide (CO ₂)

11. TOXICOLOGICAL INFORMATION

Acute inhalation toxicity Pentafluoroethane	: > 769000 ppm Exposure time: 4 h Species: rat
Difluoromethane	: LC50: > 520000 ppm Exposure time: 4 h Species: rat
Sensitisation Pentafluoroethane	: Cardiac sensitization Species: dogs Note: No-observed-effect level 75 000 ppm Lowest observable effect level 100 000 ppm
Difluoromethane	: Cardiac sensitization Species: dogs Note: No-observed-effect level >350 000 ppm
Repeated dose toxicity Pentafluoroethane	: Species: rat Application Route: Inhalation Exposure time: (4 Weeks) NOEL: 50000 ppm Subchronic toxicity
Difluoromethane	: Species: rat

8/12

Genetron® AZ-20 (R-410A)**00000009881**

Version 1.0 0

Issuing date 02/27/2012

Revision Date 02/27/2012

Print Date 01/30/2014

Application Route: Inhalation
 Exposure time: (90 d)
 NOEL: 50000 ppm
 Subchronic toxicity

Germ cell mutagenicity
 Pentafluoroethane

: Test Method: Ames test
 Result: negative

Difluoromethane

: Test Method: Ames test
 Result: negative

: Cell type: Human lymphocytes
 Result: negative

: Cell type: Chinese Hamster Ovary Cells
 Result: negative

: Cell type: Human lymphocytes
 Result: negative

Method: Mutagenicity (in vitro mammalian cytogenetic test)

: Test Method: Chromosome aberration test in vitro
 Result: negative

Germ cell mutagenicity
 Difluoromethane

: Species: mouse
 Cell type: Bone marrow
 Method: Mutagenicity (micronucleus test)
 Result: negative

Teratogenicity
 Pentafluoroethane

: Species: rabbit
 Application Route: Inhalation exposure
 NOEL, Teratog: 50,000 ppm
 NOEL, Maternal: 50,000 ppm
 Note: Did not show teratogenic effects in animal experiments.

Species: rat
 Application Route: Inhalation exposure
 NOEL, Teratog: 50,000 ppm
 NOEL, Maternal: 50,000 ppm
 Note: Did not show teratogenic effects in animal experiments.

Difluoromethane

: Species: rat
 Dose: NOEL - 50,000 ppm
 Note: Did not show teratogenic effects in animal experiments.

Species: rabbit
 Dose: NOEL - 50,000 ppm
 Note: Did not show teratogenic effects in animal experiments.

Genetron® AZ-20 (R-410A)

00000009881

Version 1.0 0

Issuing date 02/27/2012

Revision Date 02/27/2012

Print Date 01/30/2014

Further information

Acute toxicity

: Vapours are heavier than air and can cause suffocation by reducing oxygen available for breathing. Rapid evaporation of the liquid may cause frostbite. May cause cardiac arrhythmia.

12. ECOLOGICAL INFORMATION

Biodegradability

Pentafluoroethane

: Result: Not readily biodegradable.
Value: 5 %
Method: OECD 301 D

Difluoromethane

: Note: Minimal

Other adverse effects

Additional ecological information

: We have no quantitative data concerning the ecological effects of this product.

13. DISPOSAL CONSIDERATIONS

Disposal methods

: In accordance with local and national regulations.

14. TRANSPORT INFORMATION

IATA

UN/ID No.

: UN 3163

Description of the goods

: Liquefied gas, n.o.s.
(Pentafluoroethane, Difluoromethane)

Class

: 2.2

Labels

: 2.2

Packing instruction (cargo aircraft)

: 200

Packing instruction (passenger aircraft)

: 200

IMDG

UN/ID No.

: UN 3163

10/12

Genetron® AZ-20 (R-410A)**00000009881**

Version 1.0 0

Issuing date 02/27/2012

Revision Date 02/27/2012

Print Date 01/30/2014

Description of the goods : LIQUEFIED GAS, N.O.S.
(PENTAFLUOROETHANE, DIFLUOROMETHANE)
Class : 2.2
Labels : 2.2
EmS Number 1 : F-C
EmS Number 2 : S-V
Marine pollutant : no

15. REGULATORY INFORMATION**National regulatory information**

High Pressure Gas Law : Gases
JP HPG

Vessel Safety Law Japan : Gases
JP VSL

Aviation Law Japan : Gases
JP AVL

Other international regulations**Notification status**

1907/2006 (EU) : This mixture contains only ingredients which have been subject to a pre-registration according to Regulation (EC) No. 1907/2006 (REACH).

US. Toxic Substances : On TSCA Inventory
Control Act

Australia. Industrial Chemical : On the inventory, or in compliance with the inventory
(Notification and Assessment) Act

Canada. Canadian : All components of this product are on the Canadian DSL list.
Environmental Protection Act
(CEPA). Domestic
Substances List (DSL).
(Can. Gaz. Part II, Vol. 144)

Japan. Kashin-Hou Law List : On the inventory, or in compliance with the inventory

Korea. Existing Chemicals : On the inventory, or in compliance with the inventory
Inventory (KECI)

Philippines. The Toxic : On the inventory, or in compliance with the inventory
Substances and Hazardous
and Nuclear Waste Control

Genetron® AZ-20 (R-410A)

000000009881

Version 1.0 0

Issuing date 02/27/2012

Revision Date 02/27/2012

Print Date 01/30/2014

Act

China. Inventory of Existing Chemical Substances : On the inventory, or in compliance with the inventory

NZIOC - New Zealand : On the inventory, or in compliance with the inventory

16. OTHER INFORMATION

	HMIS III	NFPA
Health hazard	: 1	2
Flammability	: 1	1
Physical Hazard	: 0	
Instability	:	0

Further information

none

1.8.7 Refrigerant R448A

Honeywell Solstice® N40 Refrigerant (R-448A)

000000017419

Version 4.0

Revision Date 18.08.2020

Supersedes 3

SECTION 1: Identification of the substance/mixture and of the company/undertaking

1.1. Product identifier

Product name : Honeywell Solstice® N40 Refrigerant (R-448A)
SDS-number : 000000017419
Type of product : Mixture
Remarks : SDS according to Art. 31 of Regulation (EC) 1907/2006.

1.2. Relevant identified uses of the substance or mixture and uses advised against

Use of the Substance/Mixture : Refrigerant

Uses advised against : none

1.3. Details of the supplier of the safety data sheet

Company : Honeywell Fluorine Products Europe B.V.
Stationsplein Zuid-West 961
1117 CE Schiphol-Oost
Netherlands
Honeywell International, Inc.
115 Tabor Road
Morris Plains, NJ 07950-2546
USA
Telephone : +32 16 391 211
Telefax :
For further information,
please contact: : PMTEU Product Stewardship:
SafetyDataSheet@Honeywell.com

1.4. Emergency telephone number

Emergency telephone number : +1-703-527-3887 (ChemTrec-Transport)
+1-303-389-1414 (Medical)

Country based Poison Control Center : see chapter 15.1

SECTION 2: Hazards identification

2.1. Classification of the substance or mixture

REGULATION (EC) No 1272/2008

Gases under pressure Liquefied gas
H280 Contains gas under pressure; may explode if heated.

Honeywell Solstice® N40 Refrigerant (R-448A)

000000017419

Version 4.0

Revision Date 18.08.2020

Supersedes 3

2.2. Label elements

REGULATION (EC) No 1272/2008

Hazard pictograms	:		
Signal word	:	Warning	
Hazard statements	:	H280	Contains gas under pressure; may explode if heated.
Precautionary statements	:	P410 + P403	Protect from sunlight. Store in a well-ventilated place.

2.3. Other hazards

High vapour concentrations can cause headaches, dizziness, drowsiness, and nausea, and may lead to unconsciousness. May cause cardiac arrhythmia.

SECTION 3: Composition/information on ingredients

3.1. Substance

Not applicable

3.2. Mixture

Chemical name	CAS-No. Index-No. REACH Registration Number EC-No.	Classification 1272/2008	Concentration	Remarks
Difluoromethane	75-10-5 01-2119471312-47 200-839-4	Flam. Gas 1B; H221 Press. Gas ; H280	26 %	1*
Pentafluoroethane	354-33-6 01-2119485636-25 206-557-8	Press. Gas ; H280	26 %	1*
Norflurane	811-97-2 01-2119459374-33 212-377-0	Press. Gas ; H280	21 %	1*
2,3,3,3-Tetrafluoroprop-1-ene	754-12-1 01-0000019665-61 468-710-7	Press. Gas Liquefied gas; H280 Flam. Gas 1B; H221	20 %	1*

Page 2 / 15

Honeywell Solstice® N40 Refrigerant (R-448A)

000000017419

Version 4.0

Revision Date 18.08.2020

Supersedes 3

trans-1,3,3,3-Tetrafluoroprop-1-ene	29118-24-9 01-0000019758-54 471-480-0	Press. Gas ; H280	7 %	1*
-------------------------------------	---	-------------------	-----	----

1* - For specific concentration limits see Annexes of 1272/2008

Remaining components of this product are non-hazardous and/or are present at concentrations below reportable limits.

Occupational Exposure Limit(s), if available, are listed in Section 8.

For the full text of the H-Statements mentioned in this Section, see Section 16.

SECTION 4: First aid measures**4.1 Description of first aid measures***General advice:*

First aider needs to protect himself. Move out of dangerous area. Take off all contaminated clothing immediately.

Inhalation:

Remove to fresh air. Artificial respiration and/or oxygen may be necessary. Call a physician immediately.

Skin contact:

Rapid evaporation of the liquid may cause frostbite. In case of contact with liquid, thaw frosted parts with water, then remove clothing carefully. Wash with plenty of water. Consult a physician. Take off contaminated clothing and shoes immediately. Wash contaminated clothing before re-use.

Eye contact:

Remove contact lenses. Rinse immediately with plenty of water, also under the eyelids, for at least 15 minutes.

Ingestion:

Ingestion is unlikely because of the physical properties and is not expected to be hazardous. As this product is a gas, refer to the inhalation section.

4.2. Most important symptoms and effects, both acute and delayed

No data available

4.3. Indication of any immediate medical attention and special treatment needed

Do not give adrenaline or similar drugs.

See Section 11 for more detailed information on health effects and symptoms.

Honeywell Solstice® N40 Refrigerant (R-448A)

000000017419

Version 4.0

Revision Date 18.08.2020

Supersedes 3

SECTION 5: Firefighting measures

5.1. Extinguishing media

Suitable extinguishing media:

The product is not flammable.

Use water spray, alcohol-resistant foam, dry chemical or carbon dioxide.

Extinguishing media which shall not be used for safety reasons:

High volume water jet

5.2. Special hazards arising from the substance or mixture

No data available

5.3. Advice for firefighters

Wear full protective clothing and self-contained breathing apparatus.

Use extinguishing measures that are appropriate to local circumstances and the surrounding environment. In the event of fire, cool tanks with water spray.

SECTION 6: Accidental release measures

6.1. Personal precautions, protective equipment and emergency procedures

Immediately contact emergency personnel. Wear personal protective equipment. Unprotected persons must be kept away. Ensure adequate ventilation. In case of insufficient ventilation wear suitable respiratory equipment. Ensure that the oxygen content is $\geq 19.5\%$.

6.2. Environmental precautions

Prevent further leakage or spillage if safe to do so. The product evaporates readily.

6.3. Methods and materials for containment and cleaning up

Ventilate the area.

6.4. Reference to other sections

For personal protection see section 8.

SECTION 7: Handling and storage

7.1. Precautions for safe handling

Advice on safe handling:

Honeywell Solstice® N40 Refrigerant (R-448A)

000000017419

Version 4.0

Revision Date 18.08.2020

Supersedes 3

Open drum carefully as content may be under pressure. The product should only be used in areas from which all naked lights and other sources of ignition have been excluded. Pressurized container. Protect from sunlight and do not expose to temperatures exceeding 50 °C. Do not pierce or burn, even after use. Do not spray on a naked flame or any incandescent material. Do not use in areas without adequate ventilation. Contaminated equipment (brushes, rags) must be cleaned immediately with water.

Advice on protection against fire and explosion:

The product is not flammable. Can form a combustible mixture with air at pressures above atmospheric pressure.

Hygiene measures:

Handle in accordance with good industrial hygiene and safety practice. Ensure adequate ventilation, especially in confined areas. Avoid contact with skin, eyes and clothing. Remove and wash contaminated clothing before re-use. Keep working clothes separately.

7.2. Conditions for safe storage, including any incompatibilities*Further information on storage conditions:*

Store in original container. Keep away from direct sunlight. Keep containers tightly closed in a cool, well-ventilated place.

7.3. Specific end use(s)

no additional data available

SECTION 8: Exposure controls/personal protection**8.1. Control parameters***Occupational exposure limits:*

Components	Basis / Value type	Value / Form of exposure	Exceeding Factor	Remarks
Difluoromethane	HONEYWELL TWA	2.200 mg/m ³ 1.000 ppm		We are not aware of any national exposure limit.
Pentafluoroethane	HONEYWELL TWA	1.000 ppm		We are not aware of any national exposure limit.
Norflurane	HONEYWELL TWA	1.000 ppm		
Norflurane	EH40 WEL TWA	4.240 mg/m ³ 1.000 ppm		

Honeywell Solstice® N40 Refrigerant (R-448A)

000000017419

Version 4.0

Revision Date 18.08.2020

Supersedes 3

2,3,3,3-Tetrafluoroprop-1-ene	WEEL TWA	500 ppm		
2,3,3,3-Tetrafluoroprop-1-ene	HONEYWELL TWA	500 ppm		
trans-1,3,3,3-Tetrafluoroprop-1-ene	HONEYWELL TWA	800 ppm		We are not aware of any national exposure limit.

TWA - Time weighted average

DNEL/ PNEC-Values

Component	End-use/impact	Exposure duration	Value	Exposure routes	Remarks
Difluoromethane	Workers / Long-term systemic effects		7035 mg/m3	Inhalation	
Difluoromethane	Consumers / Long-term systemic effects		750 mg/m3	Inhalation	
Pentafluoroethane	Workers / Long-term systemic effects		16444 mg/m3	Inhalation	
Pentafluoroethane	Consumers / Long-term systemic effects		1753 mg/m3	Inhalation	
Norflurane	Workers / Long-term systemic effects		13936 mg/m3	Inhalation	
Norflurane	Consumers / Long-term systemic effects		2476 mg/m3	Inhalation	
2,3,3,3-Tetrafluoroprop-1-ene	Workers / Long-term systemic effects		950 mg/m3	Inhalation	
2,3,3,3-Tetrafluoroprop-1-ene	Consumers / Long-term systemic effects		113,1 mg/m3	Inhalation	
2,3,3,3-Tetrafluoroprop-1-ene	Consumers / Acute systemic effects		186400 mg/m3	Inhalation	

Page 6 / 15

Honeywell Solstice® N40 Refrigerant (R-448A)

000000017419

Version 4.0

Revision Date 18.08.2020

Supersedes 3

trans-1,3,3,3-Tetrafluoroprop-1-ene	Workers / Long-term systemic effects		3902 mg/m3	Inhalation	
trans-1,3,3,3-Tetrafluoroprop-1-ene	Consumers / Long-term systemic effects		830 mg/m3	Inhalation	

Component	Environmental compartment / Value	Remarks
Difluoromethane	Fresh water: 0,142 mg/l	Assessment factor: 1000
Difluoromethane	Fresh water sediment: 0,534 mg/kg dw	
Pentafluoroethane	Fresh water: 0,1 mg/l	Assessment factor: 1000
Pentafluoroethane	Fresh water sediment: 0,6 mg/kg dw	
Norflurane	Fresh water: 0,1 mg/l	Assessment factor: 1000
Norflurane	Marine water: 0,01 mg/l	Assessment factor: 10000
Norflurane	Fresh water sediment: 0,75 mg/kg	Assessment factor: 100
Norflurane	Sewage treatment plant: 73 mg/l	Assessment factor: 10
2,3,3,3-Tetrafluoroprop-1-ene	Fresh water: 0,1 mg/l	
2,3,3,3-Tetrafluoroprop-1-ene	Marine water: 0,01 mg/l	
2,3,3,3-Tetrafluoroprop-1-ene	Fresh water sediment: 1,77 mg/kg	
2,3,3,3-Tetrafluoroprop-1-ene	Marine sediment: 0,178 mg/kg	
2,3,3,3-Tetrafluoroprop-1-ene	Soil: 1,54 mg/kg	
trans-1,3,3,3-Tetrafluoroprop-1-ene	Fresh water: 0,1 mg/l	Assessment factor: 1000

8.2. Exposure controls**Occupational exposure controls**

The Personal Protective Equipment must be in accordance with EN standards: respirator EN 136, 140, 149; safety glasses EN 166; protective suit: EN 340, 463, 468, 943-1, 943-2; gloves EN 374, 511;

Honeywell Solstice® N40 Refrigerant (R-448A)

000000017419

Version 4.0

Revision Date 18.08.2020

Supersedes 3

safety shoes EN-ISO 20345.

Personal protective equipment

Respiratory protection:

In case of insufficient ventilation wear suitable respiratory equipment.

Self-contained breathing apparatus (EN 133)

Hand protection:

Protective gloves against cold

(EN 511)

Gloves must be inspected prior to use.

Replace when worn.

Eye protection:

Safety glasses with side-shields conforming to EN166

Face-shield

Skin and body protection:

Protective footwear

Environmental exposure controls

Handle in accordance with local environmental regulations and good industrial practices.

SECTION 9: Physical and chemical properties

9.1. Information on basic physical and chemical properties

Form	: Liquefied gas
Colour	: clear colourless
Odour	: slight ether-like
Melting point/range	: No data available
Boiling point/boiling range	: -45,9 - -39,8 °C
Flash point	: Not applicable
Auto-ignition temperature	: 628 °C
Vapour pressure	: 1.120 kPa at 21,1 °C
Vapour pressure	: 2.588 kPa

Page 8 / 15

Honeywell Solstice® N40 Refrigerant (R-448A)

000000017419

Version 4.0

Revision Date 18.08.2020

Supersedes 3

	at 54,4 °C
Density	: 1,11 g/cm ³
pH	: neutral
Water solubility	: No data available
Partition coefficient: n-octanol/water	: No data available
Relative vapour density	: 2,98 (Air = 1.0)

9.2 Other Information

no additional data available

SECTION 10: Stability and reactivity**10.1. Reactivity**

Stable under normal conditions.
Hazardous polymerisation does not occur.

10.2. Chemical stability

No data available

10.3. Possibility of hazardous reactions

No data available

10.4. Conditions to avoid

Heating will cause pressure rise with risk of bursting
Pressurized container. Protect from sunlight and do not expose to temperatures exceeding 50 °C.
Do not pierce or burn, even after use. Do not spray on a naked flame or any incandescent material.

10.5. Incompatible materials

oxidising substances
Possible incompatibility with alkali sensitive materials.
Powdered metals

10.6. Hazardous decomposition products

Page 9 / 15

Honeywell Solstice® N40 Refrigerant (R-448A)

000000017419

Version 4.0

Revision Date 18.08.2020

Supersedes 3

Halogenated compounds
Hydrogen fluoride
Carbonyl halides
Carbon oxides

SECTION 11: Toxicological information

11.1. Information on toxicological effects

Acute oral toxicity:
Not applicable

Acute dermal toxicity:
No data available

Acute inhalation toxicity:
LC50
Species: Rat
Value: > 520000 ppm
Exposure time: 4 h
Test substance: Difluoromethane (HFC-32)

LC50
Species: Rat
Value: > 769000 ppm
Exposure time: 4 h
Test substance: Ethane, pentafluoro- (HFC-125)

LC50
Species: Rat
Value: > 500000 ppm
Exposure time: 4 h
Test substance: 1,1,1,2-tetrafluoroethane (HFC-134a)

LC50
Species: Rat
Value: > 400000 ppm
Exposure time: 4 h
Test substance: 2,3,3,3-Tetrafluoroprop-1-ene

Skin irritation:
No data available

Eye irritation:
No data available

Respiratory or skin sensitisation:
No data available

Honeywell Solstice® N40 Refrigerant (R-448A)

000000017419

Version 4.0

Revision Date 18.08.2020

Supersedes 3

Aspiration hazard:

No data available

Other information:

May cause cardiac arrhythmia.

Difluoromethane. (HFC-32): Cardiac sensitisation threshold (dog): 350000 ppm.

Ethane, pentafluoro- (HFC-125): Cardiac sensitisation threshold (dog): 75000 ppm.

1,1,1,2-tetrafluoroethane (HFC-134a): Cardiac sensitisation threshold (dog): 80000 ppm.

SECTION 12: Ecological information**12.1. Toxicity***Toxicity to fish:*

LC50

Species: Cyprinus carpio (Carp)

Value: > 197 mg/l

Exposure time: 96 h

Test substance: 2,3,3,3-Tetrafluoroprop-1-ene

Toxicity to aquatic plants:

EC50

Species: Scenedesmus capricornutum (fresh water algae)

Value: > 100 mg/l

Test substance: 2,3,3,3-Tetrafluoroprop-1-ene

Toxicity to aquatic invertebrates:

EC50

Species: Daphnia magna (Water flea)

Value: > 83 mg/l

Exposure time: 48 h

Test substance: 2,3,3,3-Tetrafluoroprop-1-ene

12.2. Persistence and degradability*Biodegradability:*

Result: Not readily biodegradable.

Test substance: 2,3,3,3-Tetrafluoroprop-1-ene

Biodegradability:

Biodegradation: 5 %

Result: Not readily biodegradable.

Test substance: Ethane, pentafluoro- (HFC-125)

12.3. Bioaccumulative potential

Page 11 / 15

Honeywell Solstice® N40 Refrigerant (R-448A)

000000017419

Version 4.0

Revision Date 18.08.2020

Supersedes 3

No data available

12.4. Mobility in soil

No data available

12.5. Results of PBT and vPvB assessment

No data available

12.6. Other adverse effects

No data available

SECTION 13: Disposal considerations

13.1. Waste treatment methods

Product:

Dispose according to legal requirements.

Packaging:

Legal requirements are to be considered in regard of reuse or disposal of used packaging materials

Further information:

Provisions relating to waste:
EC Directive 2006/12/EC; 2008/98/EEC
Regulation No. 1013/2006

For personal protection see section 8.

SECTION 14: Transport information

ADR/RID

UN Number	:	3163
Description of the goods	:	LIQUEFIED GAS, N.O.S. (PENTAFLUOROETHANE, DIFLUOROMETHANE, 1,1,1,2- TETRAFLUOROETHANE)
Class	:	2
Classification Code	:	2A
Hazard Identification Number	:	20
ADR/RID-Labels	:	2.2
Environmentally hazardous	:	no

IATA

UN Number	:	3163
Description of the goods	:	Liquefied gas, n.o.s.

Page 12 / 15

Honeywell Solstice® N40 Refrigerant (R-448A)

000000017419

Version 4.0

Revision Date 18.08.2020

Supersedes 3

(Pentafluoroethane, Difluoromethane, 1,1,1,2-Tetrafluoroethane)

Class : 2.2
Hazard Labels : 2.2

IMDG

UN Number : 3163
Description of the goods : LIQUEFIED GAS, N.O.S.
(PENTAFLUOROETHANE, DIFLUOROMETHANE, 1,1,1,2-TETRAFLUOROETHANE)

Class : 2.2
Hazard Labels : 2.2
EmS Number : F-C, S-V
Marine pollutant : no

SECTION 15: Regulatory information**15.1 Safety, health and environmental regulations/legislation specific for the substance or mixture****Poison Control Center**

Country	Phone Number
Austria	+4314064343
Belgium	070 245245
Bulgaria	(+35929154233
Croatia	(+3851)23-48-342
Cyprus	+357 2240 5611
Czech Republic	+420224919293; +420224915402
Denmark	82121212
Estonia	16662; (+372)6269390
Finland	9471977
France	+33(0)145425959
Greece	+30 210 779 3777
Hungary	(+36-80)201-199
Iceland	5432222
Ireland	+353(1)8092166
Italy	0382 24444
Germany	Berlin : 030/19240
	Bonn : 0228/19240

Country	Phone Number
Liechtenstein	+41 442515151
Lithuania	+370532362052
Luxembourg	070245245; (+352)80002-5500
Malta	+356 2395 2000
Netherlands	030-2748888
Norway	22591300
Poland	+48 42 25 38 400
Portugal	808250143
Romania	+40 21 318 3606
Slovakia (NTIC)	+421 2 54 774 166
Slovenia	+386 1 400 6051
Spain	+34915620420
Sweden	112 (begär Giftinformation);+46104566786
Switzerland	145
United Kingdom	(+44) 844 892 0111

Honeywell Solstice® N40 Refrigerant (R-448A)

000000017419

Version 4.0

Revision Date 18.08.2020

Supersedes 3

	Erfurt : 0361/730730
	Freiburg : 0761/19240
	Göttingen : 0551/19240
	Homburg : 06841/19240
	Mainz : 06131/19240
	Munich : 089/19240
Latvia	+37167042473

Other inventory information

US. Toxic Substances Control Act
 On TSCA Inventory

Australia. Industrial Chemical (Notification and Assessment) Act
 On the inventory, or in compliance with the inventory

Canada. Canadian Environmental Protection Act (CEPA). Domestic Substances List (DSL)
 All components of this product are on the Canadian DSL

Japan. Kashin-Hou Law List
 On the inventory, or in compliance with the inventory

Korea. Existing Chemicals Inventory (KECI)
 On the inventory, or in compliance with the inventory

Philippines. The Toxic Substances and Hazardous and Nuclear Waste Control Act
 Not in compliance with the inventory

China. Inventory of Existing Chemical Substances (IECSC)
 On the inventory, or in compliance with the inventory

New Zealand. Inventory of Chemicals (NZIoC), as published by ERMA New Zealand
 On the inventory, or in compliance with the inventory

15.2 Chemical safety assessment

A Chemical Safety Assessment has not been carried out.

SECTION 16: Other information

Text of H-statements referred to under heading 3

Difluoromethane	:	H221	Flammable gas.
		H280	Contains gas under pressure; may explode

Page 14 / 15

Honeywell Solstice® N40 Refrigerant (R-448A)

000000017419

Version 4.0

Revision Date 18.08.2020

Supersedes 3

if heated.

Pentafluoroethane	:	H280	Contains gas under pressure; may explode if heated.
Norflurane	:	H280	Contains gas under pressure; may explode if heated.
2,3,3,3-Tetrafluoroprop-1-ene	:	H221 H280	Flammable gas. Contains gas under pressure; may explode if heated.
trans-1,3,3,3-Tetrafluoroprop-1-ene	:	H280	Contains gas under pressure; may explode if heated.

Further information

All directives and regulations refer to amended versions.

Vertical lines in the left hand margin indicate a relevant amendment from the previous version.

Abbreviations:

EC European Community

CAS Chemical Abstracts Service

DNEL Derived no effect level

PNEC Predicted no effect level

vPvB Very persistent and very bioaccumulative substance

PBT Persistent, bioaccumulative und toxic substance

The information provided in this Safety Data Sheet is correct to the best of our knowledge, information and belief at the date of its publication. The information given is designed only as a guidance for safe handling, use, processing, storage, transportation, disposal and release and is not to be considered a warranty or quality specification. The information relates only to the specific material designated and may not be valid for such material used in combination with any other materials or in any process, unless specified in the text. Final determination of suitability of any material is the sole responsibility of the user.

This information should not constitute a guarantee for any specific product properties.

Chapter 2 Name of Each Section

2.1 Name of Each Section (1)

HRZ***-WS-F HRZ***-W1S-F HRZ***-W2S-F

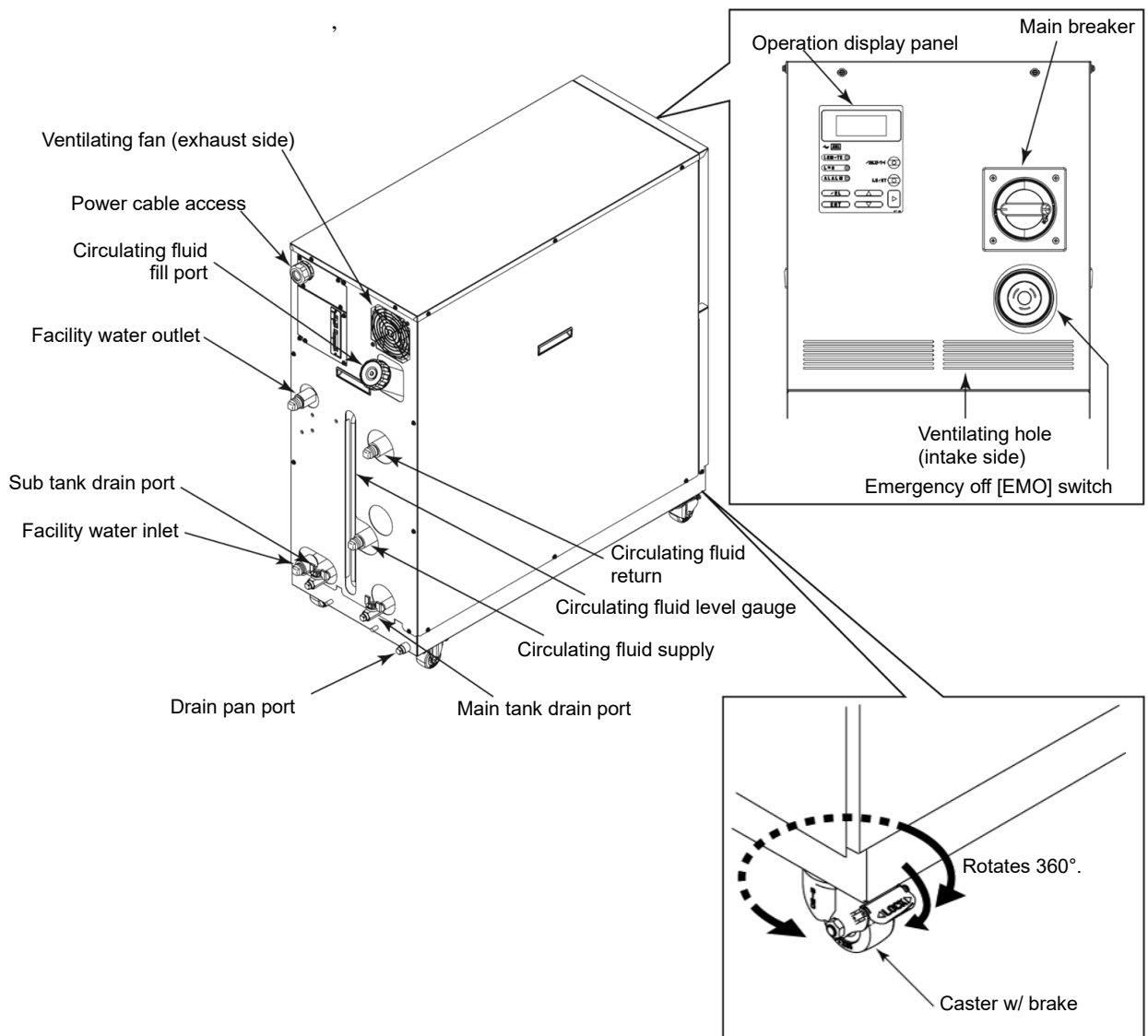

Figure 2-1 Name of Each Section (1)

[Tips]

The front casters (2 pcs.) have built-in brakes. The disengagement of the brakes is required when transporting the system.

2.2 Name of Each Section (2)

HRZ008-L-F HRZ008-L1-F

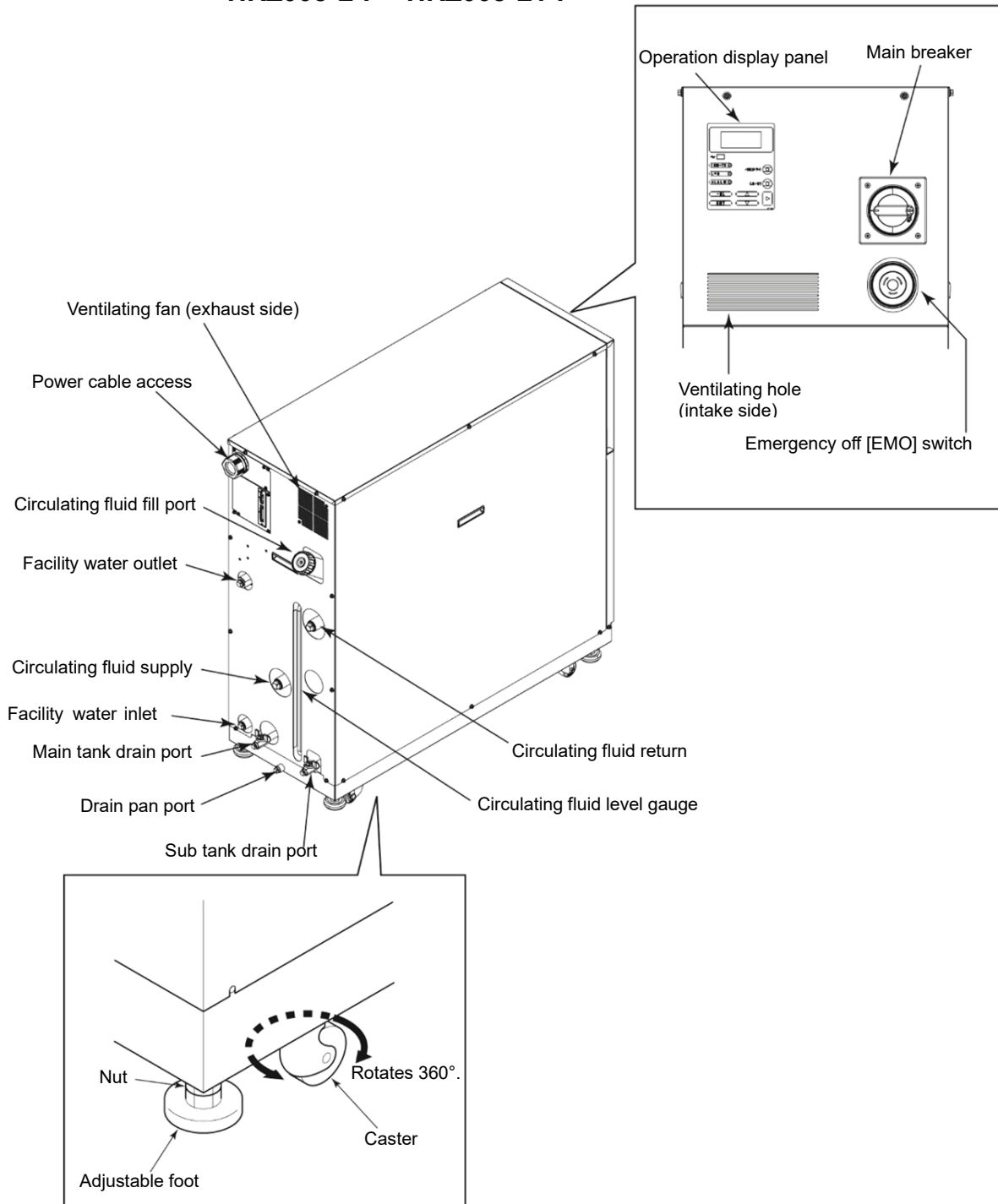

Figure 2-2 Name of Each Section (2)

CAUTION



When transporting the system with the casters, raise the adjustable feet (4 pcs.) to the highest position and lock them with the nuts. The adjustable foot at the lower position may cause damage to this system and personal injury through contact with the floor or steps during system transport.

Chapter 3 Transporting and Installation

⚠ WARNING



Proper procedure must be followed when using this system. Exercise caution to assure personnel safety during the installation, operation, maintenance, and inspection of the system.

⚠ WARNING



Only personnel, who have adequate knowledge and experiences with not only this system but associated equipment are allowed to perform transport, installation, and maintenance involving potential hazardous task.

3.1 Transporting

This system is heavy, which poses potential danger at transportation. When transporting this system, the following safety precautions should be observed to prevent system damage and breakdown.

⚠ WARNING



For transporting with the forklift, be sure to insert the fork into a designated position, referring to “3.1.1 Transporting with forklift” on page 3-2.

CAUTION



Do not set this system on its side during transportation. Oil in the compressor drains into the refrigerant pipe, which causes lubricant shortages leading to damage to the compressor.

CAUTION



Drain the remaining fluid out of the pipe as much as possible. The remaining fluid may spill if disregarded.

CAUTION



Exercise caution not to damage the panel and piping with the forklift when transporting the system.

3.1.1 Transporting with forklift

⚠ WARNING



- Do not set this system on its side for transportation. Potential damage to this system carrying danger of personnel injury if disregarded.
- Do not insert the fork from the back as well as front.

⚠ WARNING



- This system is heavy, and requires a forklift to safely move it.
- Forklift insertion positions are on either left or right side of this system. Always insert the forks all the way through. Be careful not to hit the casters and adjustable feet.

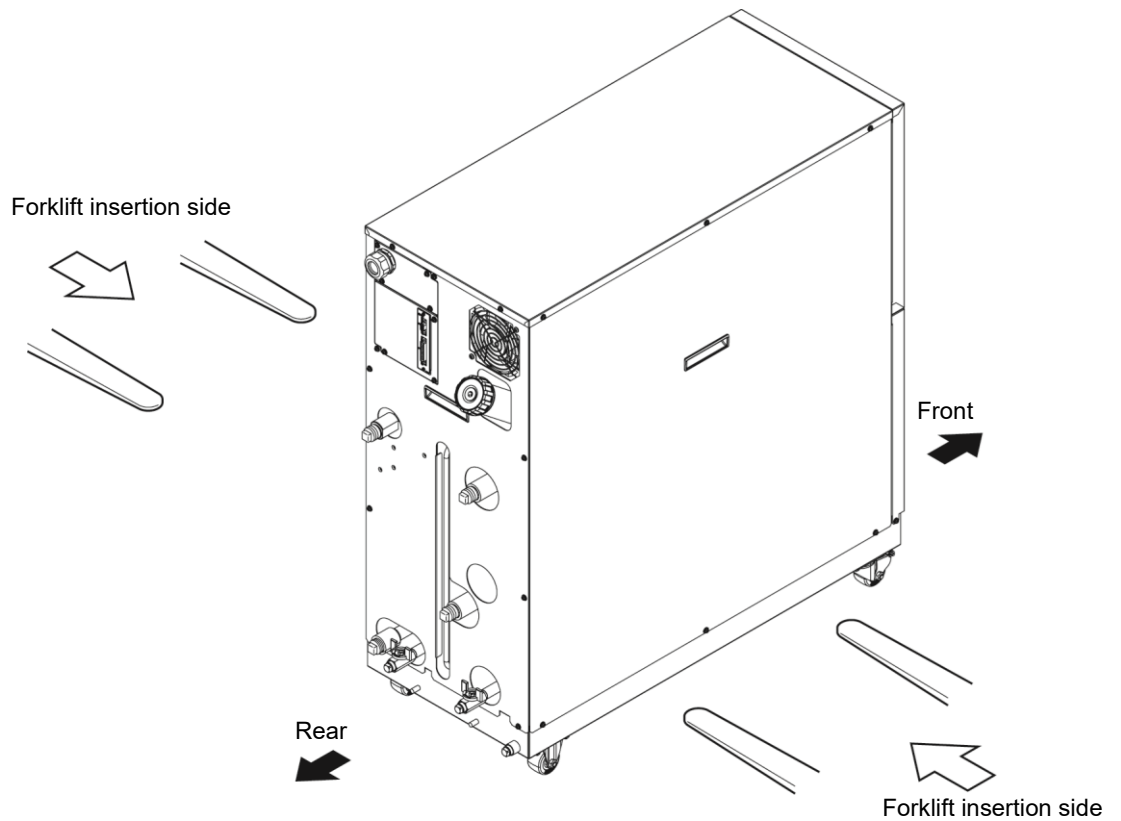

Figure 3-1 Transport with Forklift

3.1.2 Transporting with caster

WARNING



This system is heavy, which requires assistance for this work. Exercise caution and look out for sloped surfaces such as ramps, etc.

CAUTION



Do not grab piping on the back of this system or panel handles when transporting with the casters. Potential damage to piping and panels may occur if disregarded.

3.2 Installation

WARNING



System installation should be kept from areas with the potential of flammable gas leak. Ignition may occur if leaked gas is collected around the system.

WARNING



This system is NOT designed for outside use. Potential electric shock, fire and system damage may occur if exposed to rain, water and dust.

CAUTION



This system is to be installed on a level floor that can withstand the weight of this system. Potential water leak and personal injury due to system tipping over may occur if disregarded.

3.2.1 Installation conditions

System installation is not allowed outside or in the conditions described below. Potential system malfunction and damage may occur if disregarded.

Clean room specifications are not applied to this unit. The pump and ventilating fan installed in this unit generate particles.

- Location that is exposed to water vapor, salt water, and oil
- Location that is exposed to dust and powder
- Location that is exposed to corrosive gas, solvent, and flammable gas
- Location that is exposed to direct sun light or radiant heat
- Location where ambient temperature is out of the following range:
 - In operation 10 to 35 deg C
 - In storage 0 to 50 deg C(with no water or circulating fluid in piping)
- Location where relative humidity is out of the following range:
 - In operation 30 to 70%
 - In storage 15 to 85%
- Location that is subjected to abrupt changes in temperature
- Location that is subjected to intense electromagnetic noise (intense electric field, intense magnetic field, or surges)
- Location that is subjected to static electricity, or condition that discharges static electricity to the system
- Location that is subjected to strong high frequencies
- Location that is subjected to potential lightning damage
- Location with altitudes of 1000m or higher
- Location that is affected by strong vibrations or impacts
- Condition that applies external force or weight causing the system deformation
- Condition with no adequate space for maintenance as required in the installation site.

3.2.2 Installation location and maintenance work area

This system does not have ventilating hole on the both right and left sides. Although this can be installed directly contacting to walls or devices, installation with maintenance space is recommended. (See "Figure3-2)

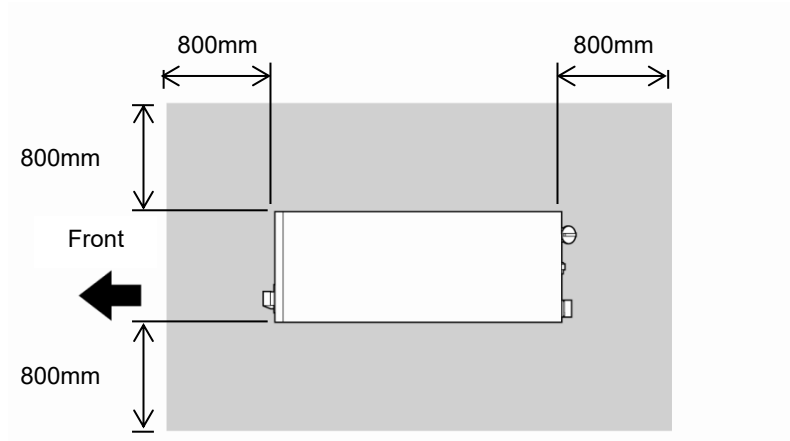

Figure 3-2 Recommended Installation Location

To save space, this system can be installed to allow access only in front and back for daily operation and inspection. For maintenance and repair work, additional access space is required for the left and right side of the system. We recommend a separate repair area, without taking space from installation site, to accommodate the needed extra space.

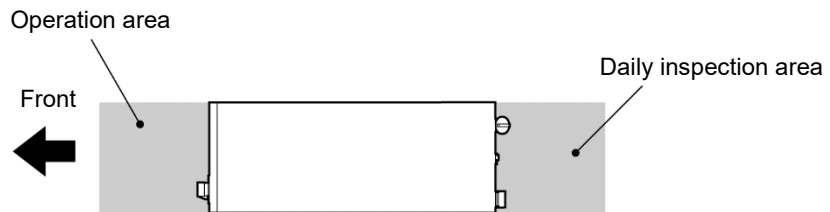

Figure 3-3 Installation Location

3.3 Procedure for Installation

CAUTION

- Anti-seismic bracket is an optional part (except for HRZ008-L-F, HRZ008-L1-F), which is required for the installation of this system (HRZ-TK002).
- Preparation of anchor bolts suitable for floor material is your responsibility. M8-anchor bolts (8 pcs.) are required for HRZ008-L-F and HRZ008-L1-F, and M12-anchor bolts (4 pcs.) for other models. See "Appendix 8.6 Anchor Bolt Mounting Position" on page 8-27.

3.3.1 Installation

- System installation should be on a vibration-free stable level plane.
- See "Appendix 8.2 Outer Dimensions" in Chapter 8 on page 8-20 for the dimensions of this system.

3.3.2 Procedure for system securing (1)

HRZ*-WS-F HRZ***-W1S-F HRZ***-W2S-F**

1. Transfer this system to the installation site.

2. Lock the brakes on casters (2 pcs. on the front).

3. Using a 13-mm open end wrench, attach the anti-seismic brackets to the front and back.

CAUTION

Drain pan port is assigned to the bottom on the back of this system. Exercise caution not to damage the drain pan port when attaching the anti-seismic bracket.

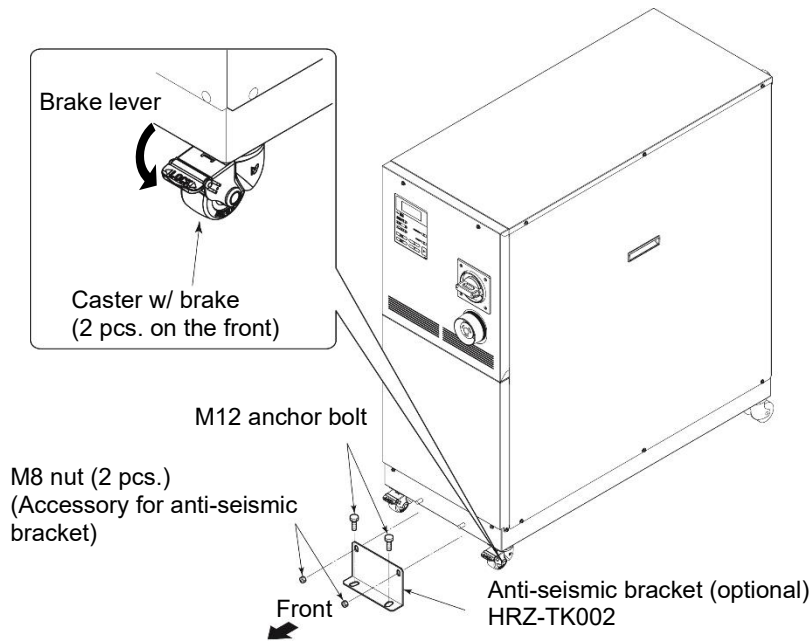

Figure 3-4 Anti-seismic Bracket Attachment

3.3.3 Procedure for system securing (2)

HRZ008-L-F HRZ008-L1-F

Adjust and secure the adjustable feet of this system to secure the anti-seismic bracket.

1. Transfer this system to the installation site.

2. Adjust the adjustable foot with a 24-mm open end wrench.

- Level the system (using a leveler) by adjusting the adjustable feet.
- All adjustable feet (4 pcs.) must touch the floor completely.
- Casters need not be touching the floor.

3. Attach the anti-seismic bracket to the adjustable foot, and tighten the nut (upper) of the adjustable foot to lock it.

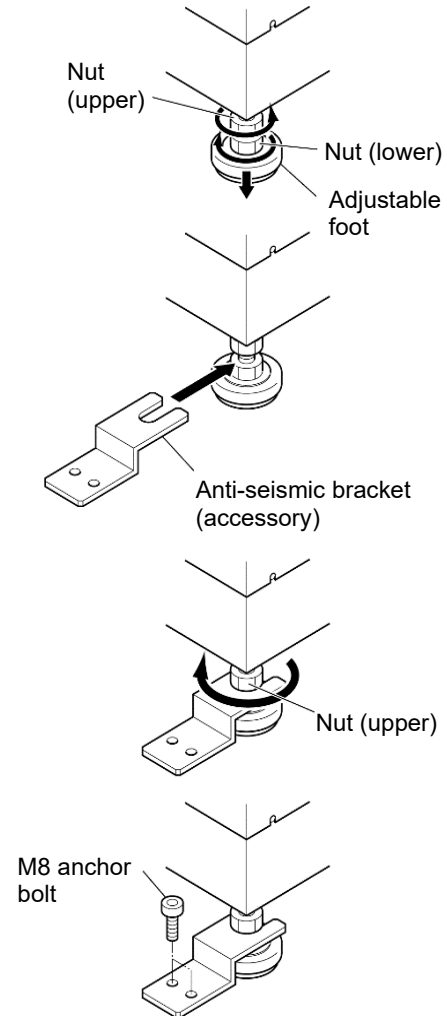



Figure 3-5 Anti-seismic Bracket Attachment

4. Secure the anti-seismic bracket with the anchor bolts. Repeat procedures for additional brackets.

3.3.4 Wiring installation

⚠ WARNING



- Only designated personnel are allowed to install wiring.
- Be sure to turn OFF the power prior to wiring to assure safety. Do not do any wiring when the system is energized.
- The system wiring requires not only a thorough connection with the designated cable but also securing to prevent loose connection. Poor connection and securing may cause electric shock, heat spots, fire or communication errors.
- Be sure to supply the power to this system according to specifications.
- Supply pure AC power. Potential malfunction may occur if a rectified AC with voltage rise (dv/dt) at zero crossing exceeds 40V /200μ sec.
- Always establish a connection to a ground for safety.
- Be sure that no ground connection is made to a water pipe, gas pipe and lighting rod.

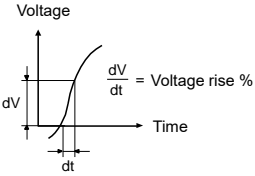

■ Power cable

The power cables are to be prepared under your responsibility, referring to the following table.

Table 3-1 Power Cable and Main Breaker (This System)

Item		HRZ002-WS-F HRZ002-W1S-F HRZ002-W2S-F	HRZ004-WS-F HRZ004-W1S-F HRZ004-W2S-F HRZ008-WS-F HRZ008-W1S-F HRZ008-W2S-F	HRZ008-L-F HRZ008-L1-F	HRZ010-WS-F HRZ010-W1S-F HRZ010-W2S-F	
Power cable	Size (recommended)	10AWG×4-conductor	10AWG×4-conductor	4AWG×4-conductor	10AWG×4-conductor	
	Crimp contact (recommended)	Breaker	R5.5-5	R5.5-5	R22-8	R5.5-8
		Earth bar	R5.5-8	R5.5-8	R22-8	R5.5-8
	Torque (recommended)	Breaker	2.5N•m (1.84 ft-lbf)	2.5N•m (1.84 ft-lbf)	6N•m (4.43 ft-lbf)	6N•m (4.43 ft-lbf)
Earth bar		12.5N•m (9.22 ft-lbf)	12.5N•m (9.22 ft-lbf)	12.5N•m (9.22 ft-lbf)	12.5N•m (9.22 ft-lbf)	
Main breaker (This System)		20A	30A	60A	30A	

■ Communication connector

The communication connectors are to be prepared under your responsibility, referring to the following table.

Table 3-2 Communication Connector

Connector	Type (for your system)
Contact signal (P1 connector)	D-Sub 25-pin (male)
Serial RS-485 (P2 connector)	D-Sub 9-pin (male)

■ Selection of the breaker for the customer's equipment (primary side)

⚠ CAUTION



This product is equipped with the breaker which has different operating characteristics depending on each model. For the customer's equipment (primary side), use the breaker whose operating time is equal to or longer than the breaker of this product. If the breaker with shorter operating time is connected, the customer's equipment could be cut off due to the inrush current of the motor of this product.

HRZ002-WS-F HRZ002-W1S-F HRZ002-W2S-F
 HRZ004-WS-F HRZ004-W1S-F HRZ004-W2S-F
 HRZ008-WS-F HRZ008-W1S-F HRZ008-W2S-F

HRZ010-WS-F HRZ010-W1S-F HRZ010-W2S-F

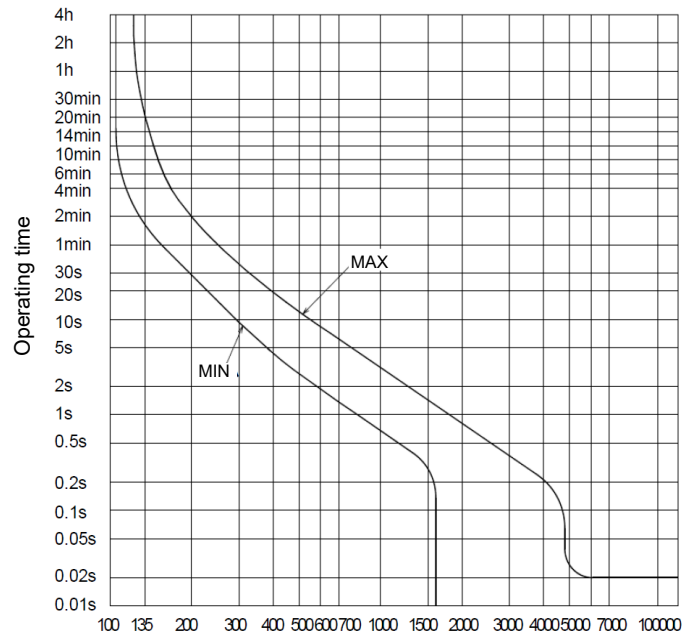
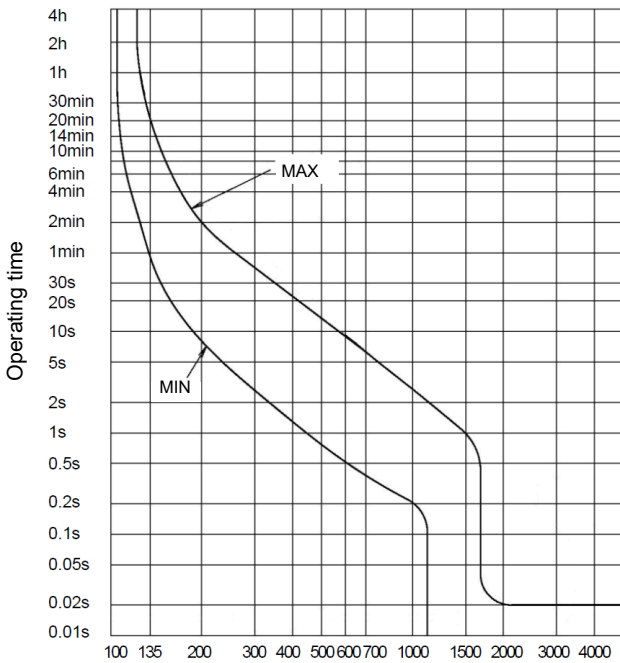

Current (% to the capacity of the main breaker of this product)

Figure 3-6 Breaker operating characteristics curve

HRZ008-L-F HRZ008-L1-F

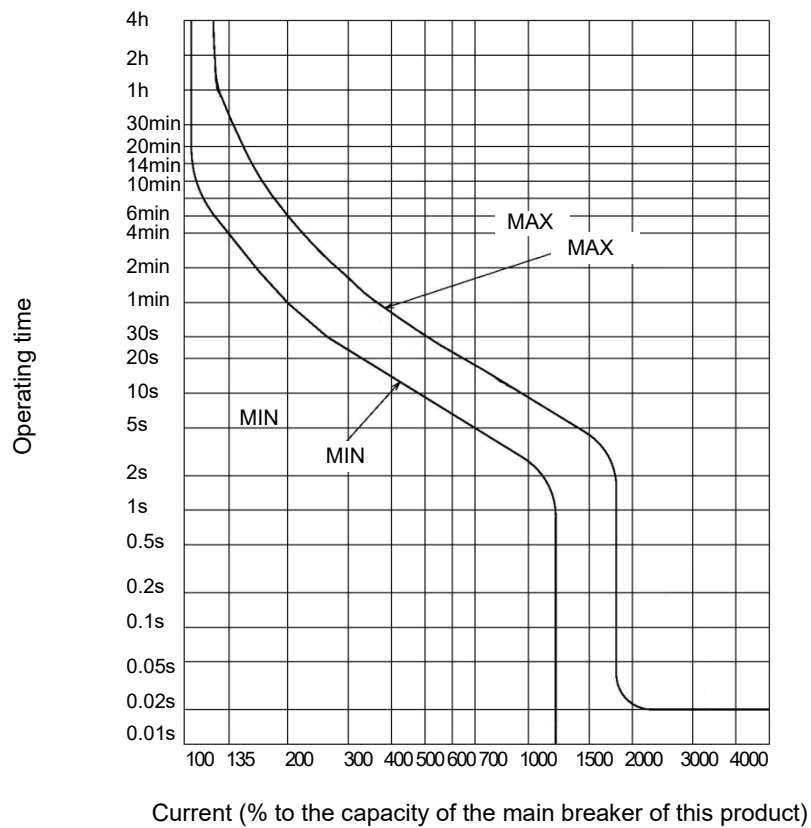

Figure 3-8 Breaker operating characteristics curve

3.3.5 Procedures for wiring installation

⚠ WARNING



Be sure to turn OFF the factory side (primary side) power before connection to this system.
Use the assigned procedure to perform lockout/tagout (Page 1-10).

1. Turn OFF the power breaker on customer side (primary side), and then use the assigned procedures to perform lockout/tagout.

[Tips]

Connection of the power cable with this system must be established first.
Do not connect the cable with the factory side at this point.

2. Turn OFF the main breaker of this system.

3. Undo the screws (2 pcs.) to remove the front panel.

Be sure to use a Phillips screwdriver.

4. Undo the screws (2 pcs.) or press claw to remove the breaker cover.

Be sure to use a Phillips screwdriver.

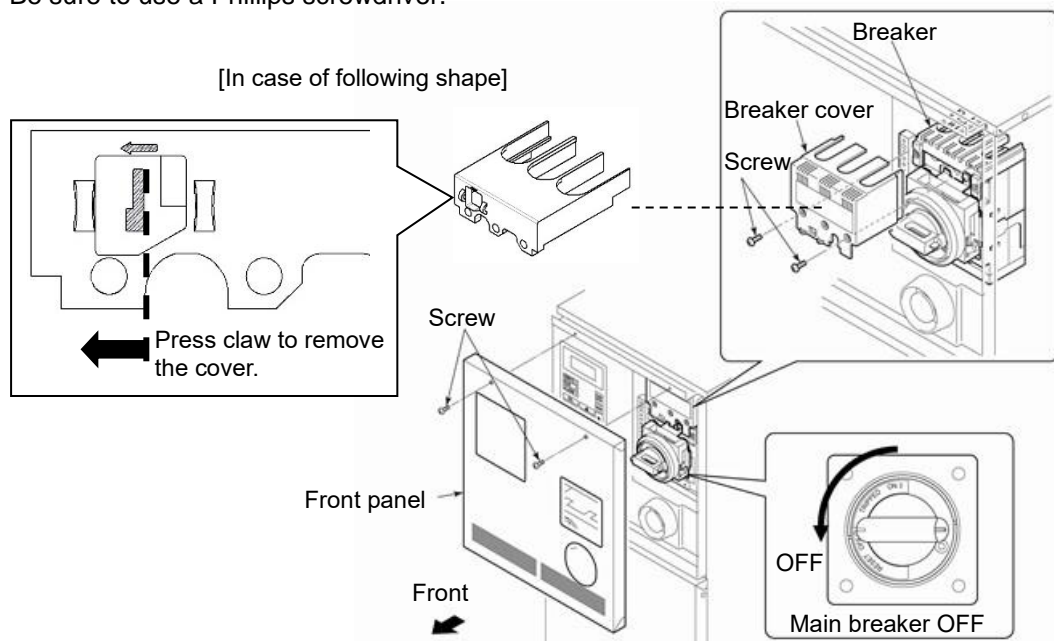

Figure 3-9 Main Breaker OFF and Removal of Front Panel/Breaker Cover

[Tips]

Make sure the breaker is at the 'OFF' position.
Otherwise, the removal of the front panel is not possible.

5. Loosen the cap at power cable access (strain relief) and insert the power cable.

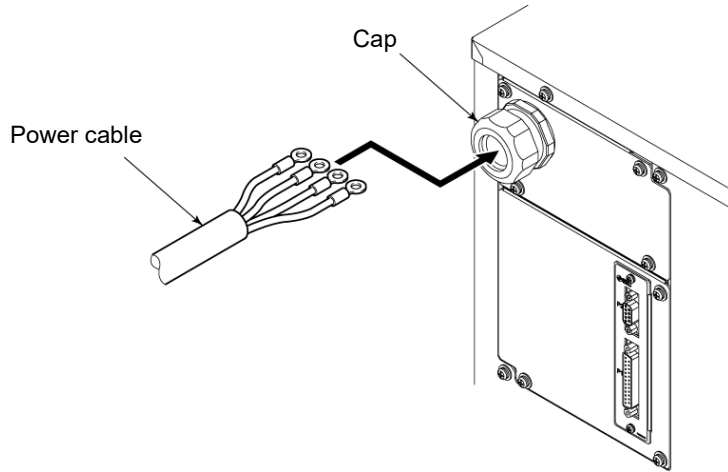

Figure 3-10 Power cable insertion

CAUTION



Correct phase rotation is required when attach the power cable to the breaker terminal.

CAUTION



Do not drop a screw or washer in the electrical unit when attaching the breaker cover and terminal.
Do not leave it in the unit if dropped in. Potential failure may occur if the power is turned ON without removing it.

[Tips]

See "Table 3-1 Power Cable and Main Breaker (This System)" on page 3-8 for the recommended cable size and crimp contact.

6. Connect the power cables to the breaker terminal.

Be sure to use a Phillips screwdriver. See Table 3-1 on Page 3-8 for recommended torque.

7. Connect the grounding terminal (M8) of the power cable to the earth bar.

Be sure to use a 13-mm open end wrench.

Recommended torque: 12.5 N•m (9.22 ft-lbf)

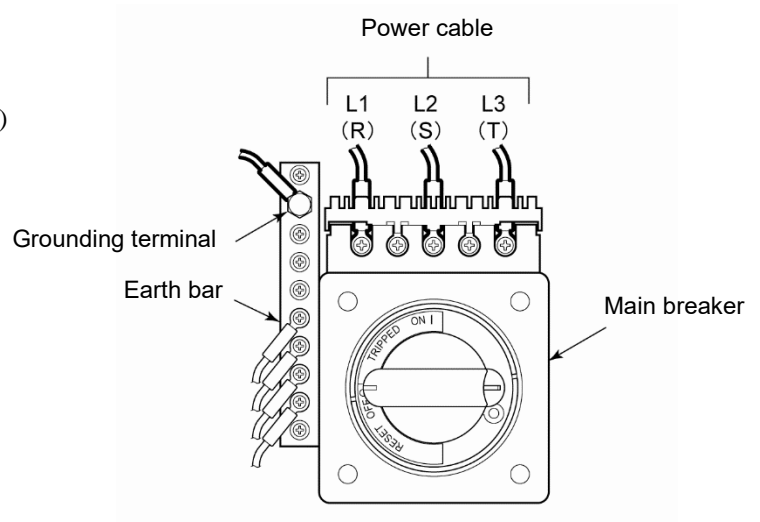

Figure 3-11 Connection of Power Cable and Grounding Terminal

[Tips]

See "Table 3-1 Power Cable and Main Breaker (This System)" on page 3-8 for torque value.

8. Attach the breaker cover to the breaker.

9. Attach the front panel.

10. Connect the power cable to the power breaker on customer side (primary side).

11. Connect the communication cables with P1 and P2.

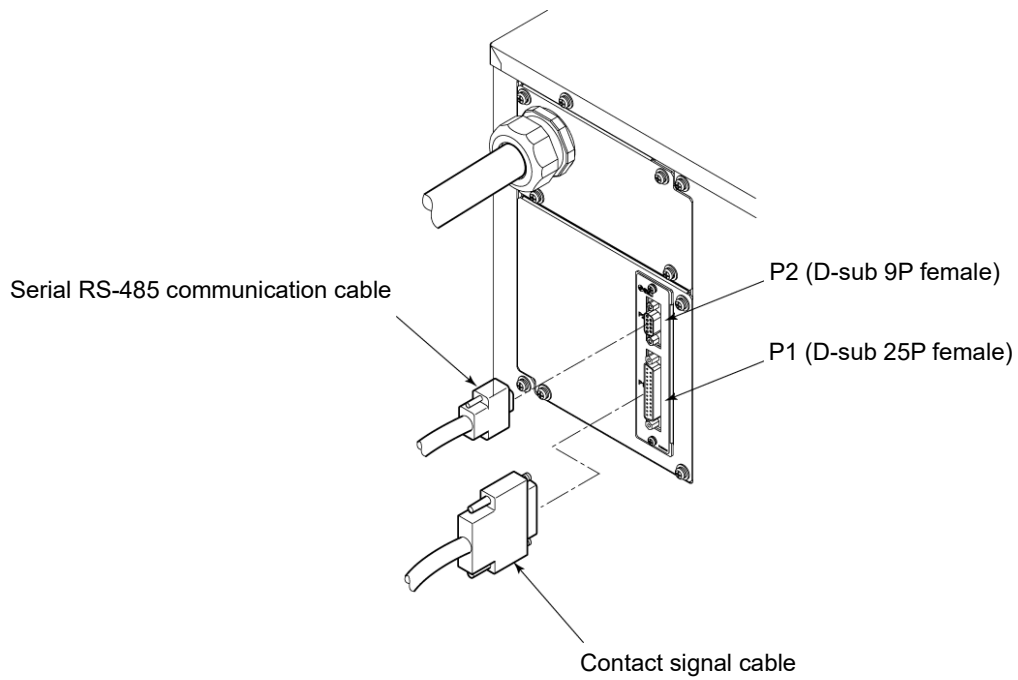

Figure 3-12 Signal line mounting

3.3.6 Installation of circulating fluid and facility water piping

⚠ CAUTION



- Regarding the circulating fluid and facility water pipings, consider carefully the suitability for operating pressure, temperature circulating fluid and facility water. If the operating performance is not sufficient, the pipings may burst during operation. Also, the use of corrosive materials such as aluminum or iron for fluid contact parts, such as piping, may not only lead to clogging or leakage in the circulating fluid and facility water circuits but also refrigerant leakage and other unexpected problems. Provide protection against corrosion when you use the product.
- Always insulate external circulating piping. Potential insufficient cooling performance due to heat absorption from the pipe surface and potential insufficient heating performance caused by thermal radiation if disregarded.
- When using fluorinated liquid as the circulating fluid, do not use pipe tape. Liquid leakage may occur around the pipe tape. For sealant, we recommend that you use the following sealant: SMC Part No., HRZ-S0003 (Silicone sealant)
- Use clean pipes and pipe fittings, free of particles, oil and moisture. Apply air blow to the parts before using. The presence of particles, oil or moisture in the circulating fluid circuit causes insufficient cooling, system failure attributed to moisture freeze when entering the system, or foaming of the circulating fluid in the tank.
- The total capacity of circulating fluid required by external piping should remain under the capacity of the sub tank. Potential problem of tank overflow, when pump stop, may occur if disregarded. See “Appendix 8.1.1 System specification” in Chapter 8 for the capacity of the sub tank.
- Be sure to choose a circulating fluid pipe capable of letting the fluid flow at rated flow rate or better. See “Pump performance” defined in “Appendix 8.1.1 System specification” for the flow rate rating.
- Have a drip pan available in case of a fluid leak.
- Do not return the circulating fluid to the unit by installing a pump in the user system.
- Make sure of the locations of ports for the circulating fluid supply, return, facility water inlet, outlet and their corresponding connections are correct.
- Secure the piping connector section with a pipe wrench, and provide proper tightening to the pipe. See Figure on page 3-13.
- Do not give an impact when the piping connector section is fixed or tightened. It may damage the piping or cause leakage.
- The flow rate of the facility water is automatically adjusted depending on using conditions. The facility water outlet temperature can be up to 60 deg.C

■ Pipe diameter

Table 3-3 Pipe Diameter

Pipe	Diameter	Recommended torque (Material: SS* vs SS)
Facility water inlet	Rc1/2	28 to 30N·m (20.7 to 22.1ft-lbf)
Facility water outlet	Rc1/2	28 to 30N·m (20.7 to 22.1ft-lbf)
Circulating fluid supply	Rc3/4	28 to 30N·m (20.7 to 22.1ft-lbf)
Circulating fluid return	Rc3/4	28 to 30N·m (20.7 to 22.1ft-lbf)
Main tank drain port	Rc3/8 (with valve)	Piping not necessary
Sub tank drain port	Rc3/8 (with valve)	Piping not necessary
Drain pan port	Rc3/8	Piping not necessary

*: SS Stainless steel

■ **Procedure for piping installation**

Secure the pipe coupling section with a pipe wrench, and provide proper tightening to the pipe.

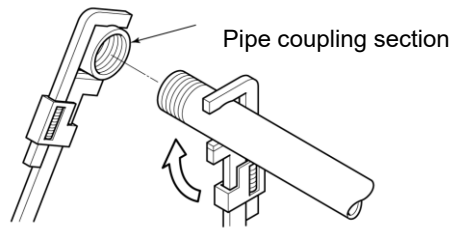

Figure 3-13 Pipe Tightening

■ **Recommended piping installation**

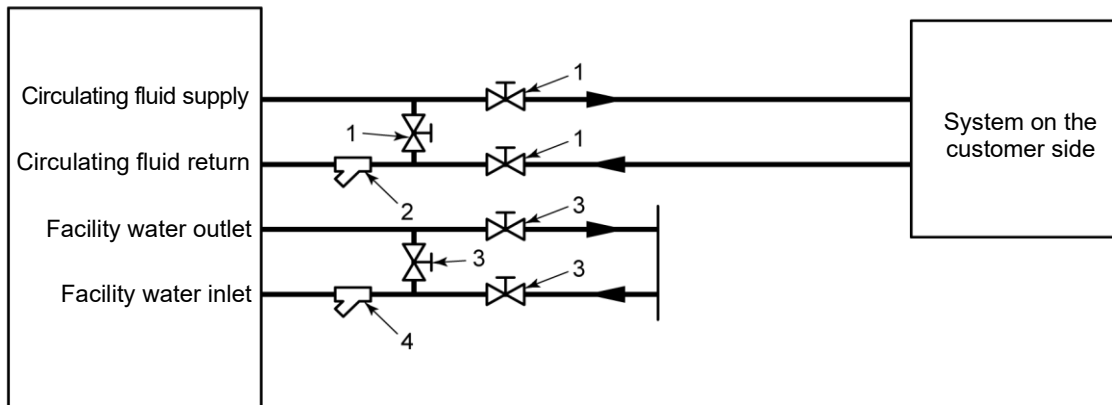

Figure 3-14 Recommended Piping Installation

Table 3-4 Recommended Pipe

No.	Name	Size	Material
1	Valve	Rc3/4	Stainless steel
2	Y-strainer (100µm)	Rc3/4	Stainless steel
3	Valve	Rc1/2	Stainless steel
4	Y-strainer (5µm)	Rc1/2	Stainless steel

CAUTION



No thermal insulator is assigned to facility water circuit. In order to avoid dew condensation of facility water circuit, retain the facility water temperature inside the range in Table 3-5 correspond to installation conditions. Otherwise please insulate the facility water piping by customer.

Table 3-5 Facility water temperature range

Installation conditions		Facility water temperature range(deg C)
Ambient temperature(deg C)	Relative humidity(%)	
35	70	29 to 30
	60	27 to 30
	50	24 to 30
	40	20 to 30
	30	15 to 30
30	70	24 to 30
	60	22 to 30
	50	19 to 30
	40	15 to 30
	30	11 to 30
25	70	20 to 30
	60	17 to 30
	50	14 to 30
	40	11 to 30
	30	10 to 30
20	70	15 to 30
	60	13 to 30
	50	10 to 30
	40	
	30	
15	70	10 to 30
	60	
	50	
	40	
	30	
10	70	10 to 30
	60	
	50	
	40	
	30	

Chapter 4 System Startup and Shutdown

⚠ CAUTION



Only personnel, who have adequate knowledge of and experiences with not only this system but associated equipment, are allowed to implement system startup and shutdown.

4.1 Pre-check

Check the following items prior to starting up the system.

4.1.1 Installation condition

- Make sure that the system is installed in a horizontal position.
- No heavy object is placed on this system. This system should not be applied with an undue force such as caused by piping installation.
- Re-check the items defined in “3.2 Installation” on page 3-3.

4.1.2 Cable connection

Make sure proper connection of the power cable, ground, and communication cables.

4.1.3 Installation of circulating fluid and facility water piping

Make sure that circulating fluid and facility water piping are installed properly.

4.1.4 Operating signal from your system

Make sure that no remote signal is being issued from your system. System startup takes effect upon power-ON if this system receives a remote signal and it is in remote mode.

4.1.5 Check emergency off [EMO] switch

Make sure of the location of the emergency off [EMO] switch before operating the system. See section 1.6.1 “Emergency off [EMO] switch” in Chapter 1 “Safety” for details.

4.2 Opening of Facility water Valve

CAUTION



Check that the facility water complies with not only the water quality standard defined in section 7.1 “Water Quality Management” on page 7-1 but the requirements provided in “8.1.1 System specification” in Chapter 8 Appendix on page 8-1.

Open the facility water valve for water supply.

[Tips]

This system is outfitted with a water regulating valve inside.
Facility water may not flow upon system startup which is normal.

4.3 Supply of Circulating Fluid

CAUTION

 Circulating fluids to use vary with system models. See section 8.1.1 “System specification” in Chapter 8 for the designated circulating fluid for a specific model.

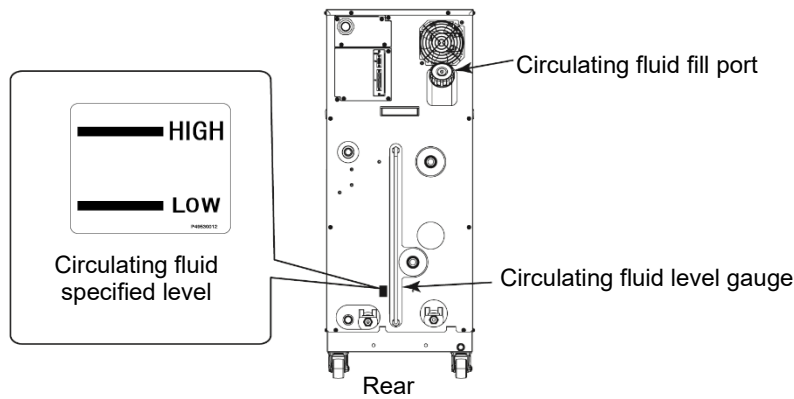

Figure 4-1 Circulating Fluid Fill Port and Circulating Fluid Level Gauge

4.3.1 Preparation of circulating fluid

■ When the circulating fluid is a 60% ethylene glycol aqueous solution

Always check the concentration of the circulating fluid.

CAUTION

- Low concentration EG in the circulating fluid may cause system failure due to it being frozen in the system.
- High concentration EG in the circulating fluid may cause circulating pump overload, which triggers “Return Low Flow FLT”.
- Potential cooling error may occur if the circulating fluid varies in concentration.

■ When the circulating fluid is a fluorinated fluid

CAUTION

Make sure of no oil, moisture, and other foreign materials contaminate the circulating fluid. Potential cooling error or system failure, due to contaminant freezes internally, may occur if disregarded.

■ When the circulating fluid is water

CAUTION

Attention should be taken on water quality. Ensure water quality is within specified range, and other foreign materials contaminate the circulating fluid. Potential cooling error or system failure, due to contaminant freezes internally, may occur if disregarded.

4.3.2 Supply of circulating fluid

Remove the circulating fluid fill cap, and fill the circulating fluid until it reaches its specified level.

The circulating fluid specified level is a range between “HIGH” and “LOW” in Figure 4-1.

Be sure to tighten the cap until it clicks after fluid supply.

If the circulating fluid is supplied over the specified level, follow the procedure provided in section 7.3.1 “Draining of circulating fluid out of tank” on page 7-4 to drain excess fluid until it reaches the specified level.

[Tips]

Level between “HIGH” and “LOW” represent liquid level in normal running condition. Immediately as you start filling up the chiller, the internal transferring pump start pumping fluid from the Sub Tank into the Main Tank. Thus the fluid level in the level gauge will start to drop.

During initial priming of the external piping, addition fluid is needed. See section 8.1.1 “System specification” on page 8-1 for Sub Tank and Main Tank capacity.

WARNING



Circulating fluid must be supplied to be in the range between “HIGH” and “LOW”. Potential overflow of hot circulating fluid may occur due to excessive volume.

Total fluid volume use to fill up the system including initial priming should not exceed combined volume of Sub Tank and Main Tank. If level is below the “LOW” mark, this system will trigger an alarm.

CAUTION



When supplying the circulating fluid, make sure that the fluid inside this system has dropped to room temperature for the prevention of burns.

CAUTION



To prevent moisture, which is formed by condensation of a flowed air, from finding its way into the tank, ensure the circulating fluid at room temperature when supplying the fluid.

Be sure to tighten the cap until it clicks after fluid supply. Potential circulating fluid vaporization or moisture intrusion due to condensation of flowed air may occur if disregarded.

4.4 Requirement for System Startup

4.4.1 Turning ON power

1. Make sure that the main breaker for this system is OFF, and release lockout/tagout of the power breaker on customer side (primary side). Then, turn ON the power.

2. Turn ON the main breaker of this system.

The “Model Indication screen” and “System Information screen” are displayed in sequence on the LCD screen. The screen will change to the “Status screen 1” in approx. 20 seconds, and the system is ready to run.

[Tips]

It is normal if the “System Information screen” is not displayed. See section 5.3.33 “System Information screen” in “Chapter 5 System Operation” on page 5-36 for details.

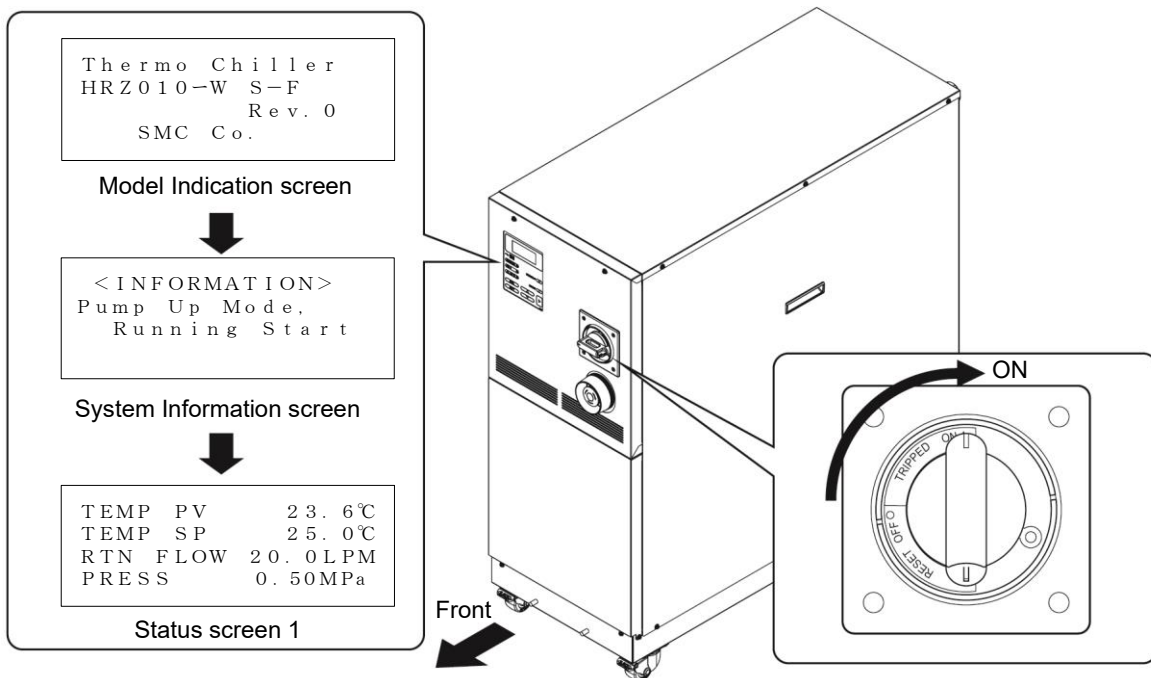

Figure 4-2 Main Breaker at 'ON'

⚠ WARNING

Press the emergency off [EMO] switch immediately upon occurrence of abnormal conditions. Be sure to turn OFF the main breaker afterwards.

4.4.2 Circulating fluid temperature setting

From the “Setting screen” on the LCD screen, set the circulating fluid at any temperature. See section 5.4 “Examples of System Operation” in “Chapter 5 System Operation” on page 5-37 for operating procedure.

[Tips]

See section 8.1.1 “System specification” in “Chapter 8 Appendix” on page 8-1 for the setting range of circulating fluid temperature.

4.5 System Startup and Shutdown

4.5.1 System startup

Press the [START/STOP] key on the operation display panel.

The [RUN] lamp on the operation display panel comes on, and the “System Information screen” is flashing. The screen then change to the “Status screen 1”, which initiates system operation.

[Tips]

It is normal if the “System Information screen” is not displayed. See section 5.3.33 “System Information screen” in “Chapter 5 System Operation” on page 5-36 for details.

4.5.2 System shutdown

Press the [START/STOP] key on the operation display panel.

The “System Information screen” is flashing on the LCD screen, and the [RUN] lamp comes on. The compressor comes to a halt approx, 20 seconds after circulating pump stop for protection of the compressor. The screen is returned to the “Setting screen 1”, which prompts the [RUN] lamp to go out.

[Tips]

See section 5.3.33 “System Information screen” in “Chapter 5 System Operation” on page 5-36 for details on the System Information screen.

CAUTION



Internal equipment may remain at elevated or lowered in temperature immediately after system shutdown. Potential burns or frostbite may happen if your skin comes in contact with these surfaces. Further work is allowed only when the system reaches room temperature.

CAUTION



Emergency off [EMO] switch and main breaker (OFF) should not be used for system shutdown unless it is an emergency.

Chapter 5 System Operation

5.1 Operation Display Panel

Use the operation display panel located in front of the system for the basic operations.

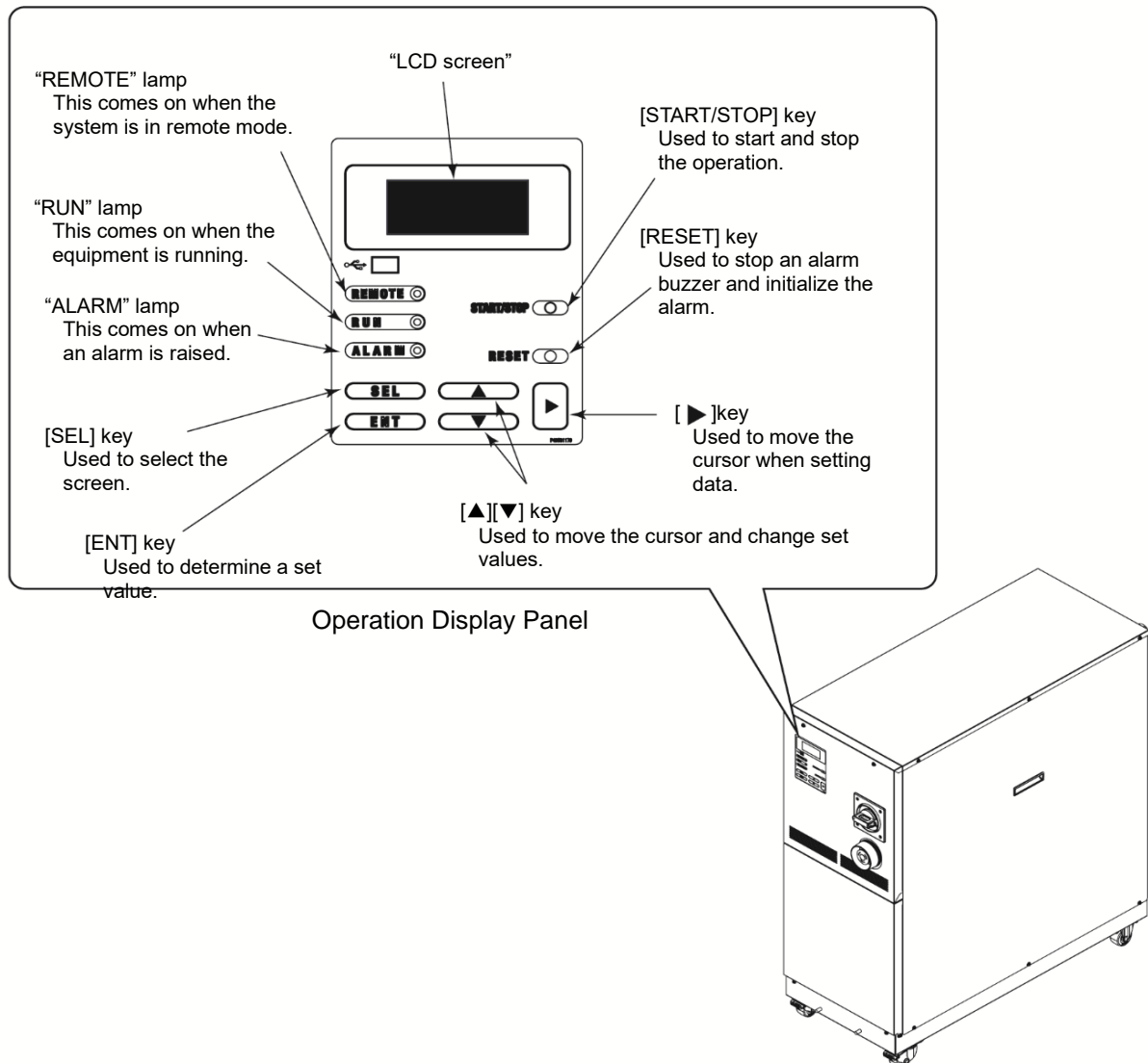

Figure 5-1 Operation Display Panel

CAUTION

Be sure to use your fingers only to operate the Operation Display Panel. Using sharp object will damage the panel.

5.2 Flow Chart of Operation Screen

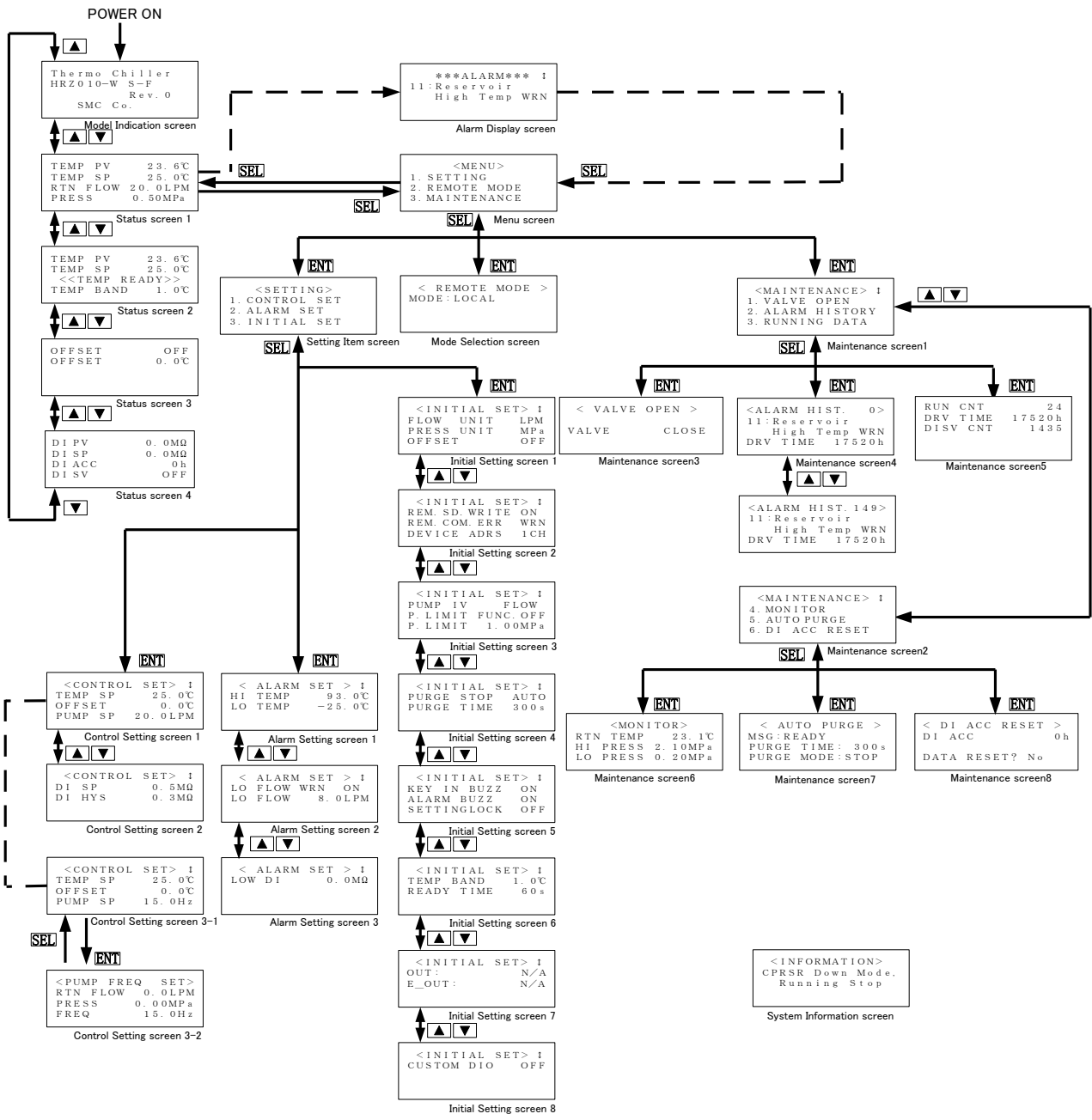

Figure 5-2 Flow Chart of Operation Screen

[Tips]

1. After the menu screen, pressing the [SEL] key can make the screen return to the previous page.
2. For the items which are set numerically can be set by minimum unit of displayed value.
3. The contents displayed on the screen may change depending on the options or settings. Please refer to the description page of each screen.

Table 5-1 Descriptions of Operation Screens

Screen	Descriptions	Reference
Model Indication screen	Displays the model and revision No. of this system.	Page 5-4
Status screen 1 to 4	Displays the operating condition of this system.	Page 5-5 to 5-8
Alarm Display screen	The alarm number and alarm message are displayed in the event of an error in this system. Not displayed if no error.	Page 5-9
Menu screen	Allows setting screen selection	Page 5-9
Setting screen	Allows switching to "Control Setting screen", "Alarm Setting screen" and "Initial Setting screen".	Page 5-10
Control screen 1, 2, 3-1, 3-2	Allows the setting of pump frequency, pressure or flow rate by pump inverter.	Page 5-11 to 5-15
Alarm Setting screen 1 to 3	Allows the setting of set values for the alarm of temperature and flow rate.	Page 5-16 to 5-18
Initial Setting screen 1 to 8	Allows the setting of set values.	Page 5-19 to 5-26
Mode Selection screen	Allows communication mode selection.	Page 5-27
Maintenance screen 1 to 8	Not used during system operation. Not allowed to use unless otherwise specified.	Page 5-28 to 5-35
System Information screen	Displays the status of system startup and shutdown.	Page 5-36

5.3 Operation Screen

5.3.1 Model Indication screen

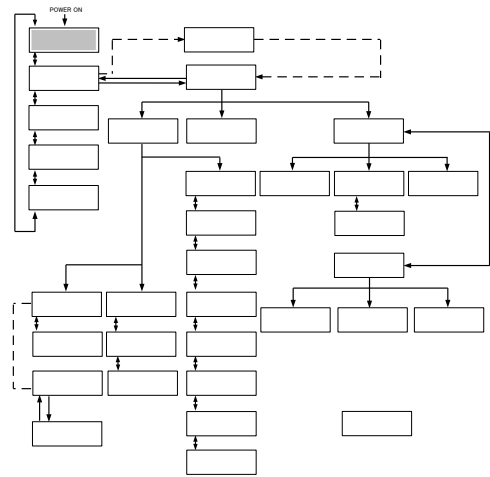
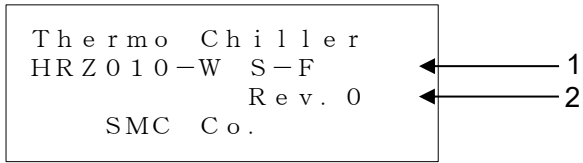

Figure 5-3 Model Indication Screen

The “Model Indication screen” is displayed upon power-ON of this system.
 This screen remains ON for approx. 5 seconds and is automatically switched to the “Status screen 1”.
 The “Alarm Display screen” is displayed if error occurs in this system.

Table 5-2 Model Indication screen

No.	Item	Descriptions
1	-	System model
2	-	System revision No.

5.3.2 Status screen 1

TEMP PV	23.6°C	← 1
TEMP SP	25.0°C	← 2
RTN FLOW	20.0 LPM	← 3
PRESS	0.50 MPa	← 4

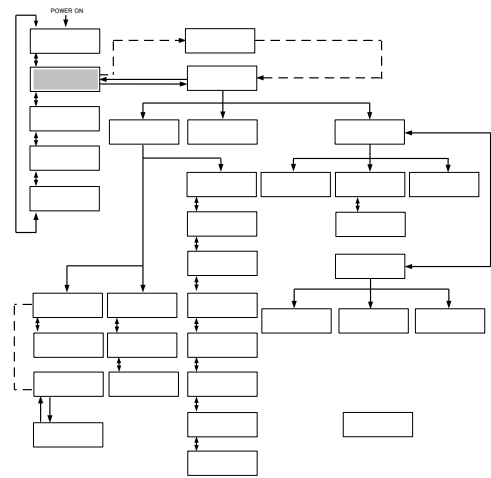

Figure 5-4 Status screen 1

Table 5-3 Status screen 1

No.	Item	Descriptions
1	TEMP PV	Discharge temperature of the circulating fluid (A value derived according to the offset*1 if applied)
2	TEMP SP	Set value of circulating fluid discharge temperature
3	RTN FLOW	Return flow rate of the circulating fluid
4	PRESS	Discharge pressure of the circulating fluid

[Tips]

See “Appendix 8.4 Offset Function” in Chapter 8 on page 8-23 for details on offset (*1).

Unit of RTN FLOW and PRESS can be selected on “Initial Setting screen 1”. See “5.3.16 Initial Setting screen 1” (page 5-19) for details.

5.3.3 Status screen 2

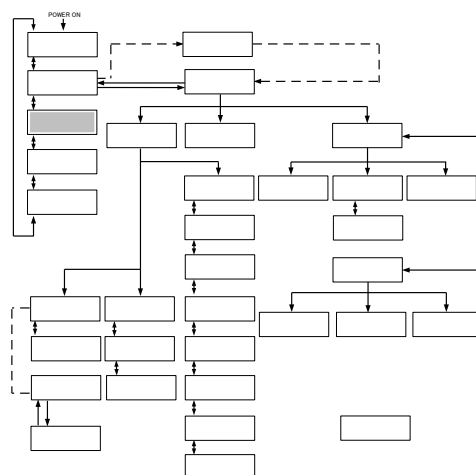
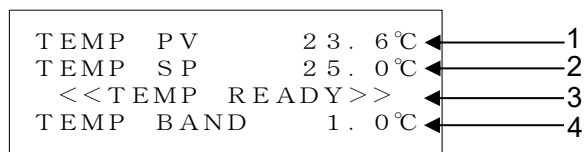

Figure 5-5 Status screen 2

Table 5-4 Status screen 2

No.	Item	Descriptions
1	TEMP PV	Discharge temperature of the circulating fluid
2	TEMP SP	Set circulating fluid temperature
3	<<TEMP READY>>	Displays the BAND/READY [Displayed when set value conditions are satisfied] *1
4	TEMP BAND	Set value of BAND range*1

[Tips]

See “Appendix 8.5 BAND/READ” in Chapter 8 on page 8-26 on offset features (*1).

5.3.4 Status screen 3

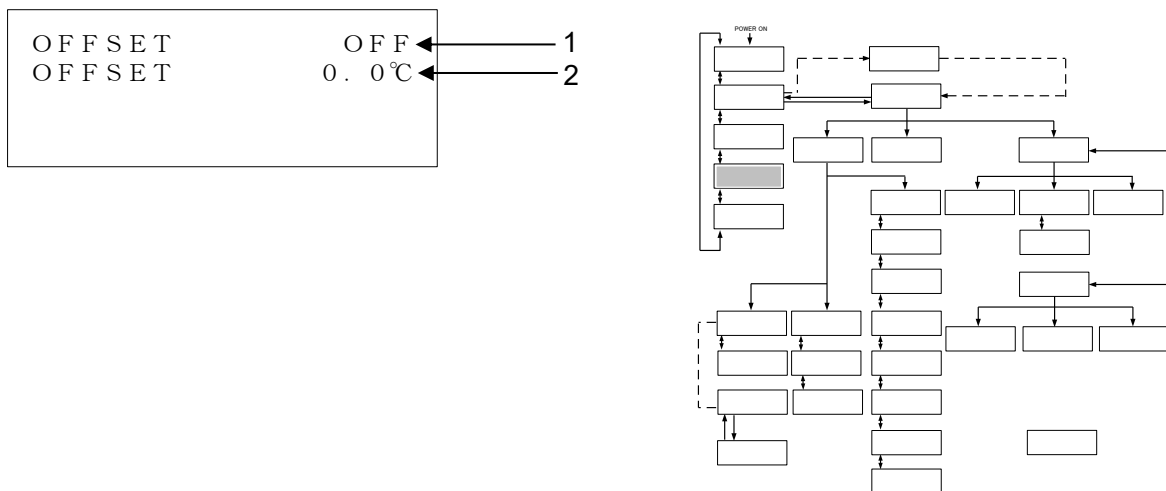

Figure 5-6 Status screen 3

Table 5-5 Status screen 3

No.	Item	Descriptions
1	OFFSET	The current offset mode ^{*1}
2	OFFSET	Set offset ^{*1}

[Tips]

See “Appendix 8.4 Offset Function” in Chapter 8 on page 8-23 on offset features (*1).

5.3.5 Status screen 4

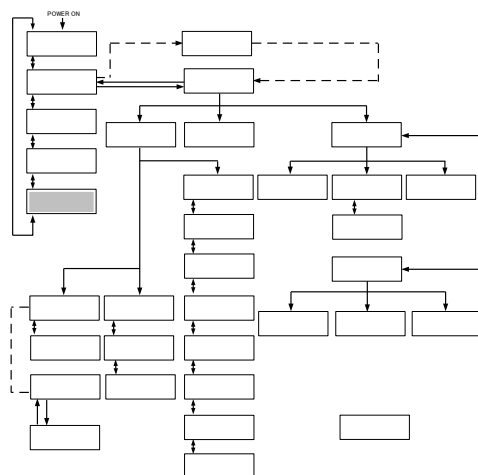
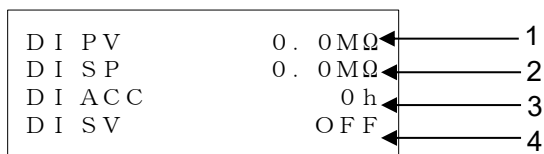

Figure 5-7 Status screen 4

Table 5-6 Status screen 4

No.	Item	Descriptions
1	DI PV	Circulating fluid electric resistivity.
2	DI SP	Set value of circulating fluid electric resistivity.
3	DI ACC	Accumulated time that the solenoid valve in DI circuit is activated.
4	DI SV	Open/close status of solenoid valve in DI circuit.

[Tips]

It is displayed only if the DI Control Kit (optional) is provided.

5.3.6 Alarm Display screen

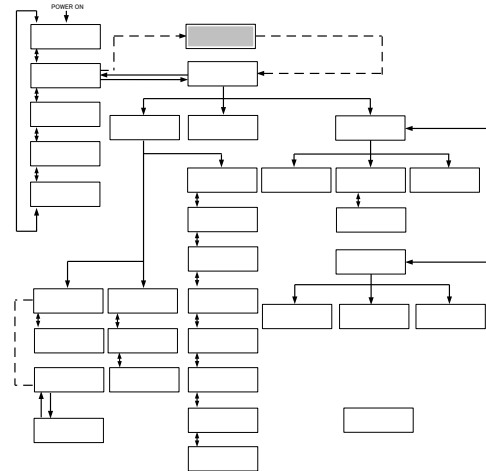
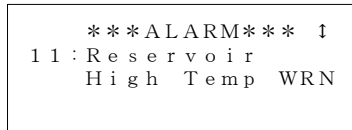

Figure 5-8 Alarm Display screen

In the event of an error in this system, the current screen is switched to the “Alarm Display screen” to display the relevant alarm code, and message.
The “Alarm Display screen” is displayed only if an error is raised.
See section 6.2 “Troubleshooting” in “Chapter 6 Error Message and Troubleshooting” on page 6-2 for alarm numbers and messages.

5.3.7 Menu screen

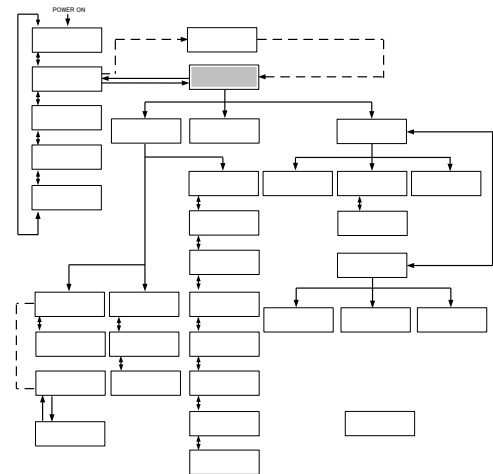
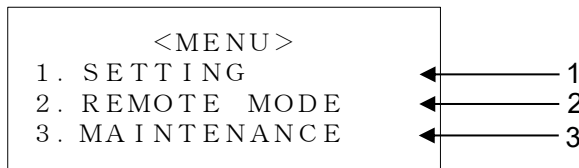

Figure 5-9 Menu screen

Table 5-7 Menu screen

No.	Item	Descriptions
1	SETTING	Switches to the “Setting screen” with the press of the [ENT] key.
2	REMOTE MODE	Switches to the “Mode Selection screen” with the press of the [ENT] key.
3	MAINTENANCE	Switches to the “Initial Setting screen 1” with the press of the [ENT] key.

[Tips]

[▲] or [▼] key is used for selecting “Item.”

5.3.8 Setting screen

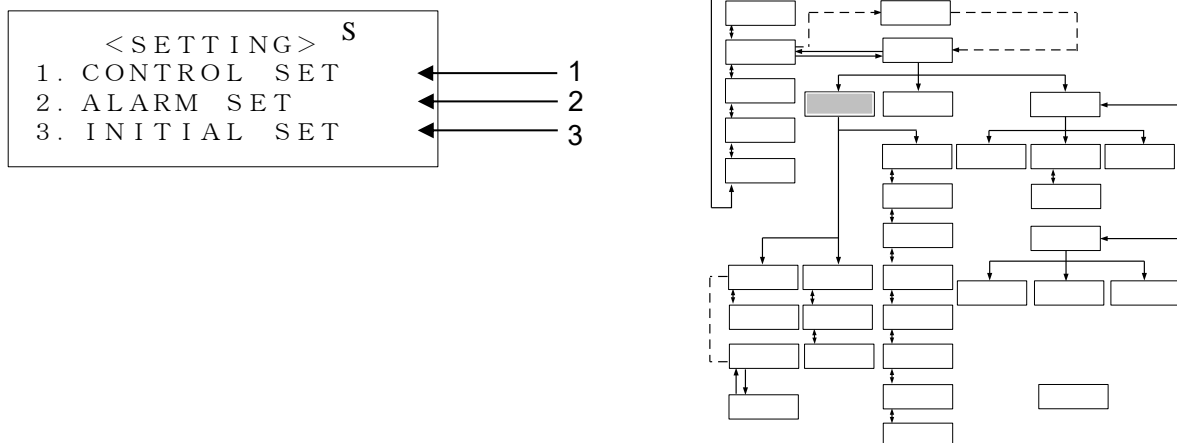

Figure 5-10 Setting screen

Table 5-8 Setting screen

No.	Item	Descriptions
1	CONTROL SET	Switches to the "Control Setting screen 1" with the press of the [ENT] key.
2	ALARM SET	Switches to the "Alarm Setting screen 1" with the press of the [ENT] key.
3	INITIAL SET	Switches to the "Initial Setting screen 1" with the press of the [ENT] key.

[Tips]

[▲] or [▼] key is used for selecting "Item."

5.3.9 Control Setting screen 1

This screen is displayed if the PUMP IV is set to PRESS or FLOW on the Initial Setting screen 3. If PUMP IV is set to FREQ, this screen is not displayed and 5.3.11 Control Setting screen 3-1 (page 5-14) is displayed.

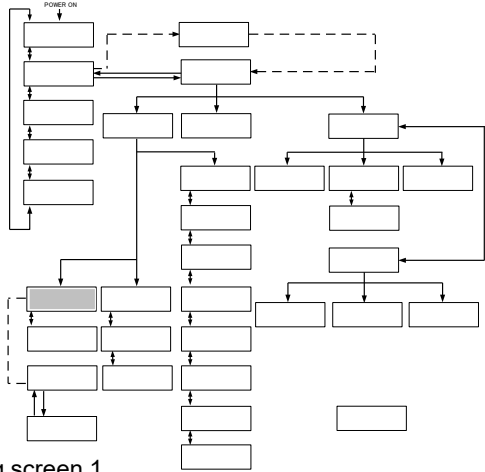
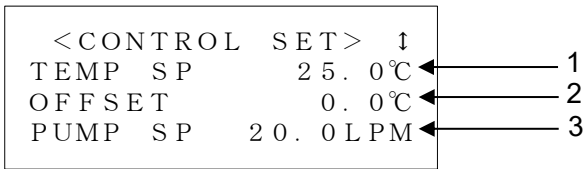

Figure 5-11 Control Setting screen 1

Table 5-9 Control Setting screen 1

No.	Item	Descriptions	Setting Range	Factory Default
1	TEMP SP	Allows the setting of circulating fluid discharge temperature.	HRZ002-WS/W1S-F : -10.0 to 90.0 deg C HRZ004/008/010-WS/W1S-F : -20.0 to 90.0 deg C HRZ***-W2S-F : 10.0 to 60.0 deg C HRZ008-L/L1-F : -20.0 to 40.0 deg C	25.0 deg C
2	OFFSET	Allows the setting of OFFSET value*1	-20.0 to 20.0 deg C	0.0 deg C
3	PUMP SP	Allows the setting of circulating fluid flow rate. (When PUMP IV on "Initial Setting screen 3" is set to FLOW.)	HRZ***-WS/W1S/W2S-F : 10.0 to 40.0LPM/2.6~10.6GPM HRZ008-L-F : 15.0 to 40.0LPM/4.0~10.6GPM HRZ008-L1-F : 10.0 to 40.0LPM/2.6~10.6GPM	HRZ***-WS/W1S/W2S-F : 20.0LPM/5.3GPM HRZ008-L-F : 30.0LPM/7.9GPM HRZ008-L1-F : 20.0LPM/5.3GPM
		Allows the setting of circulating fluid discharge pressure. (When PUMP IV on "Initial Setting screen 3" is set to PRESS.)	0.10 to 1.00MPa 15~145PSI	0.10MPa 15PSI

[Tips]

In the case of using Offset Function, select any one of MODE 1 to 3 on No.3 of "Initial Setting screen 1". See "Chapter 8 8.4 Offset Function" (page 8-23) for details.(*1).

[▲] or [▼] key is used for selecting "Item." And pressing [ENT] key enabling changing the set point.

Unit of PUMP SP can be selected on “Initial Setting screen 1”. See “5.3.16 Initial Setting screen 1” (page 5-19) for details.

5.3.10 Control Setting screen 2

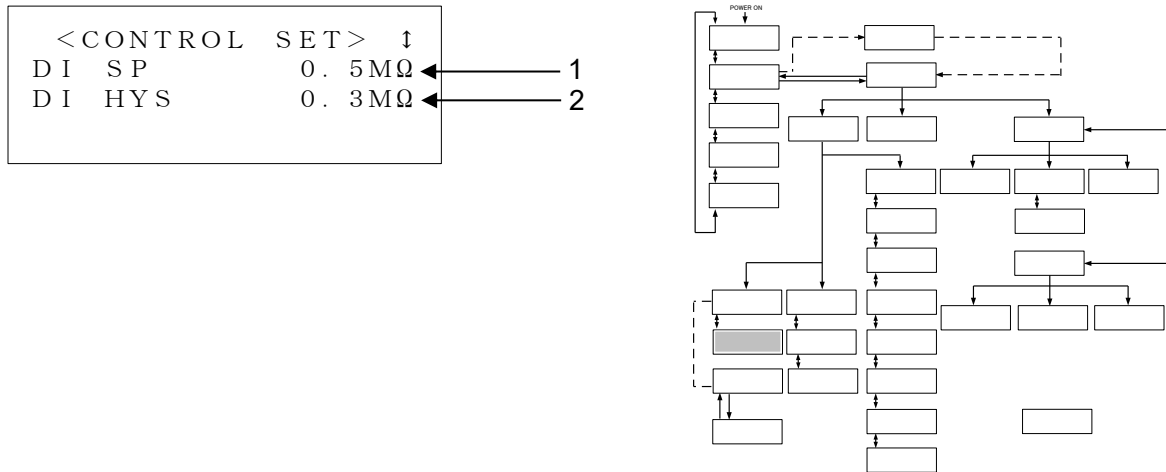

Figure 5-12 Control Setting screen 2

Table 5-10 Control Setting screen 2

No.	Item	Descriptions	Setting Range	Factory Default
1	DI SP	Allows the setting of circulating fluid electric resistivity.	0.0 to 2.0MΩ	0.5MΩ
2	DI HYS	Allows the setting of hysteresis for circulating fluid electric resistivity. (See Figure about hysteresis.)	0.0 to 0.9MΩ	0.3MΩ

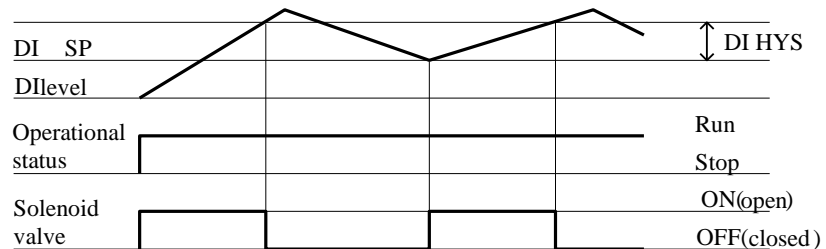

Figure 5-13 DI Hysteresis setting (DI HYS)

[Tips]

It is displayed only if the DI Control Kit (optional) is provided.

[▲] or [▼] key is used for selecting “Item.” and move to the other Control Setting screens. And pressing [ENT] key enabling changing the set point.

5.3.11 Control Setting screen 3-1

This screen is displayed if the PUMP IV is set to FREQ on the Initial Setting screen 3.

If PUMP IV is set to PRESS or FLOW, this screen will not be displayed and 5.3.9 Control Setting screen 1 (page 5-11) will be displayed.

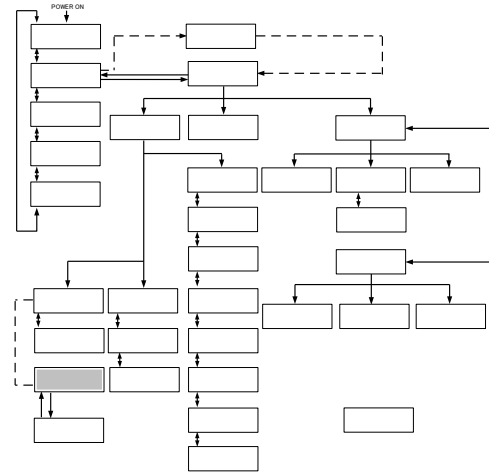
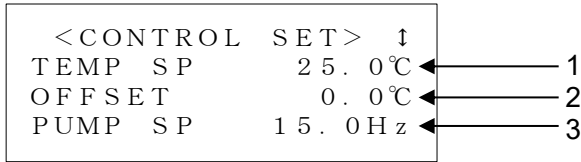

Figure 5-14 Control Setting screen3-1

Table 5-11 Control Setting screen3-1

No.	Item	Descriptions	Setting Range	Factory Default
1	TEMP SP	Allows the setting of circulating fluid discharge temperature.	HRZ002-WS/W1S-F : -10.0 to 90.0 deg C HRZ004/008/010-WS/W1S-F : -20.0 to 90.0 deg C HRZ***-W2S-F : 10.0 to 60.0 deg C HRZ008-L/L1-F : -20.0 to 40.0 deg C	25.0 deg C
2	OFFSET	Allows the setting of OFFSET value*1	-20.0 to 20.0 deg C	0.0 deg C
3	PUMP SP	Switched to the "Control Setting screen 3-2".(Pump frequency setting screen.)	-	-

[Tips]

In the case of using Offset Function, select any one of MODE 1 to 3 on No.3 of "Initial Setting screen 1". See "Chapter 8 8.4Offset Function" (page 8-23) for details (*1).

[▲] or [▼] key is used for selecting "Item." And pressing [ENT] key enabling to change the set point of TEMP SP and OFFSET.

5.3.12 Control Setting screen 3-2

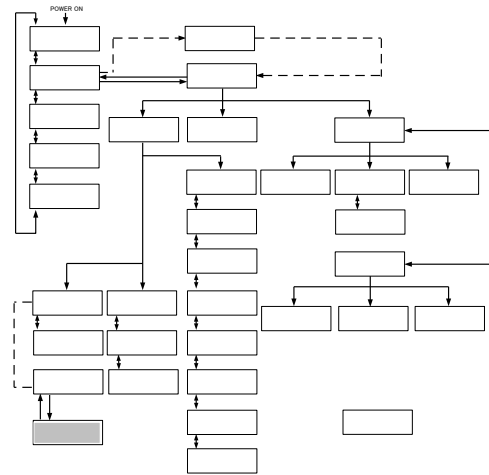
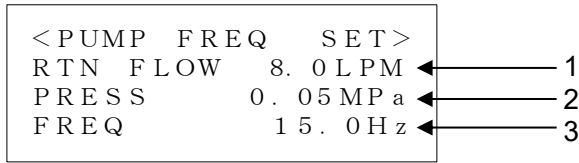

Figure 5-15 Control Setting screen 3-2

Table 5-12 Control Setting screen 3-2

No.	Item	Descriptions	Setting Range	Factory Default
1	RTN FLOW	Return flow rate of circulating fluid.	-	-
2	PRESS	Discharge pressure of circulating fluid.	-	-
3	FREQ	Allows the setting of pump frequency. (“Control Setting screen 3-2” is displayed only if PUMP IV on “Initial Setting screen 3” is set to FREQ.)	15.0 to 60.0Hz	15.0Hz

[Tips]

Pressing [ENT] key enabling to change the set point of FREQ.

Unit of RTN FLOW and PRESS can be selected on “Initial Setting screen 1”. See “5.3.16 Initial Setting screen 1”(page 5-19) for details.

5.3.13 Alarm Setting screen 1

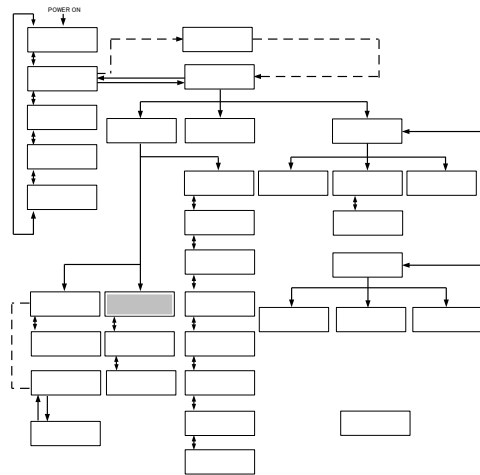
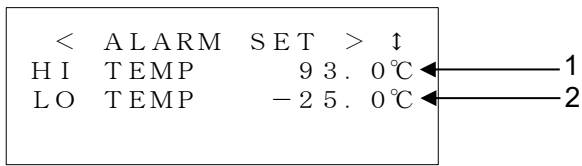

Figure 5-16 Alarm Setting screen 1

Table 5-13 Alarm Setting screen 1

No.	Item	Descriptions	Setting Range	Factory Default
1	HI TEMP	Allows the setting of temperature to generate "11:Reservoir High Temp. WRN". Alarm is raised when circulating fluid temperature exceeds the set value.	HRZ002-WS/W1S-F : -10.0 to 93.0 deg C HRZ004/008/010-WS/W1S-F : -20.0 to 93.0 deg C HRZ***-W2S-F : 10.0 to 63.0 deg C HRZ008-L/L1-F : -20.0 to 45 deg C	HRZ***-WS/W1S-F : 93.0 deg C HRZ***-W2S-F : 63.0 deg C HRZ008-L/L1-F : 45.0 deg C
2	LO TEMP	Allows the setting of temperature to generate "32:Reservoir Low Temp. WRN". Alarm is raised when circulating fluid temperature falls below the set value.	HRZ002-WS/W1S-F : -15.0 to 90.0 deg C HRZ004/008/010-WS/W1S-F : -25.0 to 90.0 deg C HRZ***-W2S-F : 5.0 to 60.0 deg C HRZ008-L/L1-F : -25.0 to 40.0 deg C	HRZ002-WS/W1S-F : -15.0°C HRZ004/008/010-WS/W1S-F : -25.0°C HRZ***-W2S-F : 5.0°C HRZ008-L/L1-F : -25.0°C

[Tips]

[▲] or [▼] key is used for selecting "Item" and move to other Alarm Setting screens. And pressing the [ENT] key enabling to change the set value.

5.3.14 Alarm Setting screen 2

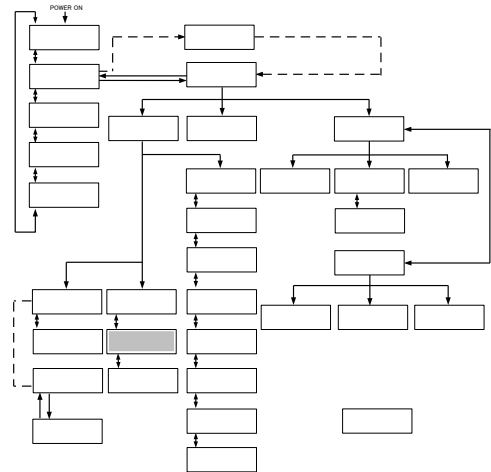
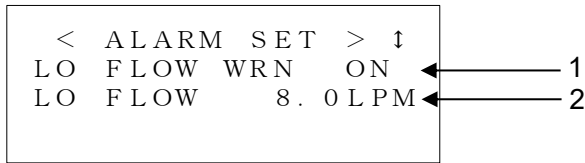

Figure 5-17 Alarm Setting screen2

Table 5-14 Alarm Setting screen 2

No.	Item	Descriptions	Setting Range	Factory Default
1	LO FLOW WRN	Allows the setting of "13:Return Low Flow WRN" (valid:ON/invalid:OFF). Alarm is not raised if invalid:OFF is selected.	OFF,ON	ON
2	LO FLOW	Allows the setting of flow rate to generate "13:Return Low Flow WRN". Alarm is raised when circulating fluid flow rate falls below the set value.	HRZ***-WS/W1S/W2S-F : 8.0 to 40.0LPM 2.1~10.6GPM HRZ008-L/L-F : 15.0~40.0LPM 4.0~10.6GPM HRZ008-L1-F : 8.0~40.0LPM 2.1~10.6GPM	HRZ***-WS/W1S/W2S-F : 8.0LPM 2.1GPM HRZ008-L/L-F : 15.0LPM 4.0GPM HRZ008-L1-F : 8.0LPM 2.1GPM

[Tips]

[▲] or [▼] key is used for selecting "Item" and move to other Alarm Setting screens. And pressing the [ENT] key enabling to change the set value.

5.3.15 Alarm Setting screen 3

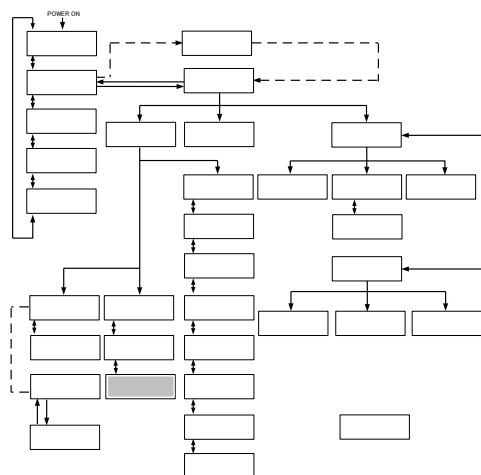
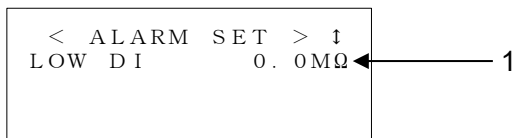

Figure 5-18 Alarm Setting screen 3

Table 5-15 Alarm Setting screen 3

No.	Item	Descriptions	Setting Range	Factory Default
1	LOW DI	Allows the setting of DI value to generate "24:DI Low Level WRN". Alarm is raised when DI value falls below the set value. Alarm is cancelled if the set value is 0.	0.0 to 2.0MΩ	0.0MΩ

[Tips]

It is displayed only if the DI Control Kit (optional) is provided.

[▲] or [▼] key is used for selecting "Item" and move to other Alarm Setting screens. And pressing the [ENT] key enabling to change the set value.

5.3.16 Initial Setting screen 1

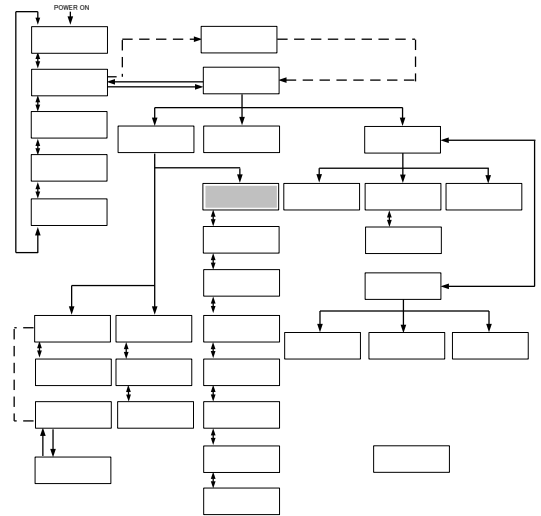
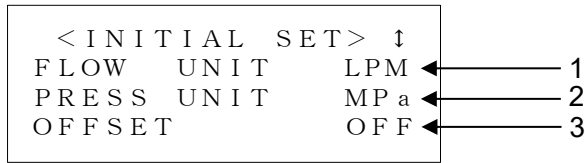

Figure 5-19 Initial Setting screen 1

Table 5-16 Initial Setting screen 1

No.	Item	Descriptions	Setting Range	Factory Default
1	FLOW UNIT	Allows the selection of the unit of flow rate.	LPM,GPM	LPM
2	PRESS UNIT	Allows the selection of the unit of pressure.	MPa,PSI	MPa
3	OFFSET	Allows the selection of Offset MODE.	MODE1 to 3,OFF	OFF

[Tips]

[▲] or [▼] key is used for selecting “Item” and move to other Initial Setting screens. And pressing the [ENT] key enabling to select the setting.

5.3.17 Initial Setting screen 2

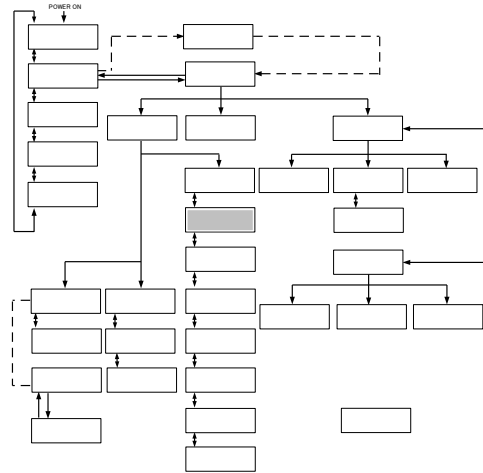
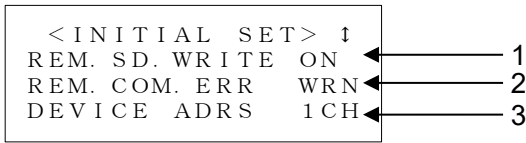

Figure 5-20 Initial Setting screen 2

Table 5-17 Initial Setting screen 2

No.	Item	Descriptions	Setting Range	Factory Default
1	REM.SD.WRITE	Store the TEMP SP and FLOW SP value with serial communication. TEMP SP and FLOW SP will be set to stored value after re-turn ON the main breaker.	OFF,ON	ON
2	REM.COM.ERR	Allows the selection of system condition when serial communication error occurs (WRN : Stop, FLT : Continued).	WRN,FLT	WRN
3	DEVICE ADRS*1	Allows the setting of the device address for serial communication.	1 to 32CH	1

[Tips]

[▲] or [▼] key is used for selecting “Item” and move to other Initial Setting screens. And pressing the [ENT] key enabling to select the setting.

*1 For HRZ010-W*S-F and HRZ008-L*-F, “SLAVE ADRS” is displayed.

5.3.18 Initial Setting screen 3

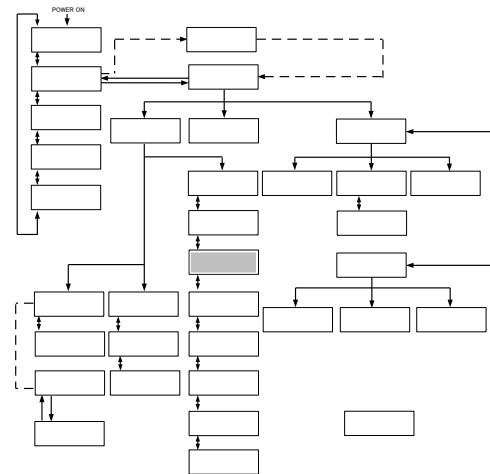
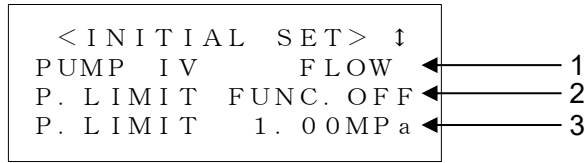

Figure 5-21 Initial Setting screen 3

Table 5-18 Initial Setting screen 3

No.	Item	Descriptions	Setting Range	Factory Default
1	PUMP IV	Allows the selection of the controlled object for pump operation. FREQ : Pump frequency control. FLOW : Circulating fluid Flow rate control. PRESS : Pump discharge pressure control.	FREQ FLOW PRESS	FLOW
2	P.LIMIT FUNC.	Allows the setting of pump discharge pressure upper limit function (Valid : ON, Invalid : OFF).	OFF,ON	OFF
3	P.LIMIT	Allows the setting of pump discharge pressure upper limit value. This function enables the pump discharge pressure not to exceed the upper limit value to protect your system.	0.10 to 1.00MPa 15~145PSI	1.00MPa 145PSI

[Tips]

[▲] or [▼] key is used for selecting “Item” and move to other Initial Setting screens. And pressing the [ENT] key enabling to select the setting or set value.

5.3.19 Initial Setting screen 4

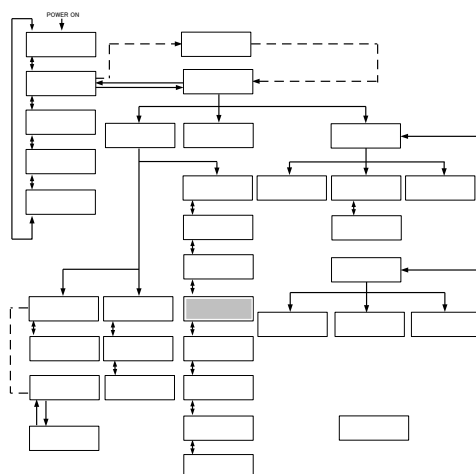

Figure 5-22 Initial Setting screen 4

Table 5-19 Initial Setting screen 4

No.	Item	Descriptions	Setting Range	Factory Default
1	PURGE STOP	Allows the selection of automatic collection stop mode. AUTO: Collection operation stops automatically when clection finished normally. TIME : Collection continues for the setting time.	AUTO,TIME	AUTO
2	PURGE TIME	When "AUTO" mode, allows the setting for the time to raise "TIME OUT". When "TIME" mode, allows the setting of the time to continue collection operation.	1 to 600sec	300s

[Tips]

It is displayed only if the Circulating Fluid Automatic Collector (optional) is provided.

[▲] or [▼] key is used for selecting "Item" and move to other Initial Setting screens. And pressing the [ENT] key enabling to select the setting.

5.3.20 Initial Setting screen 5

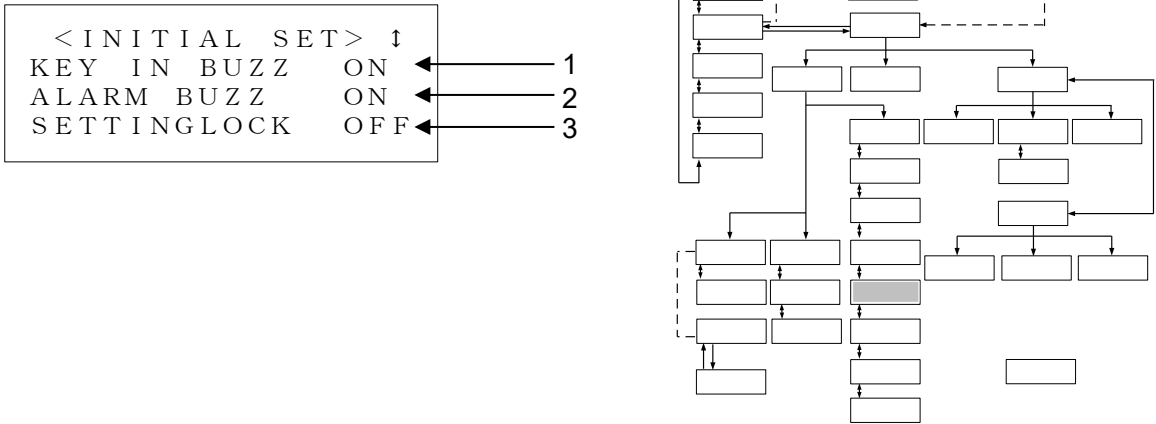

Figure 5-23 Initial Setting screen 5

Table 5-20 Initial Setting screen 5

No.	Item	Descriptions	Setting Range	Factory Default
1	KEY IN BUZZ	Allows the setting of buzzer during key input (Valid : ON, Invalid : OFF).	OFF,ON	ON
2	ALARM BUZZ	Allows the setting of alarm buzzer (Valid : ON, Invalid : OFF).	OFF,ON	ON
3	SETTINGLOCK	<p>Allow the selection of "SETTINGLOCK" function.</p> <p>This function enables to restrict the input from operation display panel to prevent from unintended change of setting value from operation touch panel.</p> <ul style="list-style-type: none"> •ALL : <ul style="list-style-type: none"> •When communication mode is "LOCAL", only following operations are possible. •START/STOP. •Setting of "SETTINGLOCK" function. •When communication mode is "DIO/SEREMOTE", only following operations are possible. •Setting of "SETTINGLOCK" function. <ul style="list-style-type: none"> •REM : <ul style="list-style-type: none"> •When communication mode is "LOCAL", normal operation is possible. •When communication mode is "DIO/SER REMOTE", only following operations are possible. •Setting of communication mode. •Setting of "SETTINGLOCK" function. •OFF : "SETTINGLOCK" function is invalid. 	OFF REM ALL	OFF

[Tips]

[▲] or [▼] key is used for selecting "Item" and move to other Initial Setting screens. And pressing the [ENT] key enabling to select the setting.

5.3.21 Initial Setting screen 6

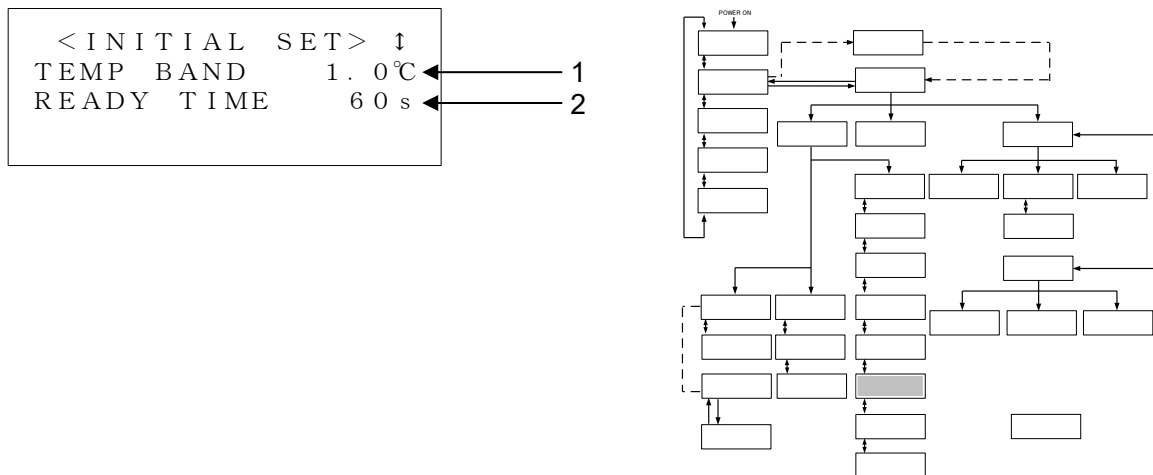

Figure 5-24 Initial Setting screen 6

Table 5-21 Initial Setting screen 6

No.	Item	Descriptions	Setting Range	Factory Default
1	TEMP BAND	Allows the setting of band range to TEMP PV.	1.0 to 99.9 deg C	1.0 deg C
2	READY TIME	Allows the setting of time from when TEMP PV reaches the BAND range to when “TEMP READY” is displayed on operation display panel and Ready signal is output.	1 to 999s	60s

[Tips]

[▲] or [▼] key is used for selecting “Item” and move to other Initial Setting screens. And pressing the [ENT] key enabling to select the set value.

5.3.22 Initial Setting screen 7

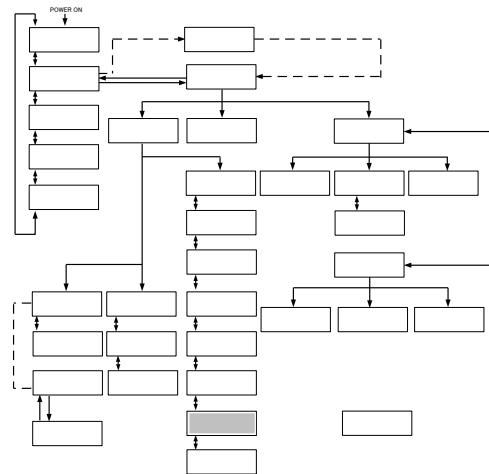
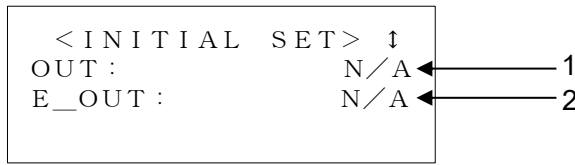

Figure 5-25 Initial Setting screen 7

Table 5-22 Initial Setting screen 7

No.	Item	Descriptions	Setting Range	Factory Default
1	OUT	Allows the selection of alarm signals for contact signal.(See"Chapter 8 8.1.7 Alarm signal selection"(page 8-19) for details.)	N/A ALARM01 to 32	N/A
2	E_OUT	Allows the selection either TEMP READY or AUTO PURGE signal.(Output for pin No. 8 of "Chapter 8 8.1.6Communication specification Table 8-7 Contact Signal "(page 8-16). See communication specification for details.	N/A TEMP READY*1 AUTO PURGE	N/A

[Tips]

See "Chapter 8 8.5 BAND/READY function"(page 8-26) for TEMP BAND, READY TIME (*1).

[▲] or [▼] key is used for selecting "Item" and move to other Initial Setting screens. And pressing the [ENT] key enabling to select the setting or set value.

5.3.23 Initial Setting screen 8

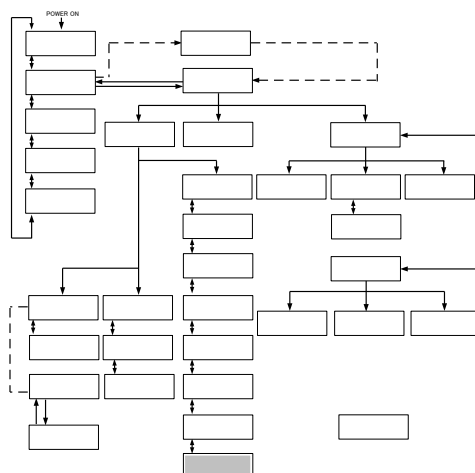

Figure 5-26 Initial Setting screen 8

Table 5-23 Initial Setting screen 8

No.	Item	Descriptions	Setting Range	Factory Default
1	CUSTOM DIO	Allows the setting for DIO signal customize (valid:ON/invalid:OFF). See "Communication Specifications" for details.	OFF,ON	OFF

[Tips]

Press the [ENT] key to make the setting changeable. Select the operation mode with the [▲] or [▼] key.

5.3.24 Mode Selection screen

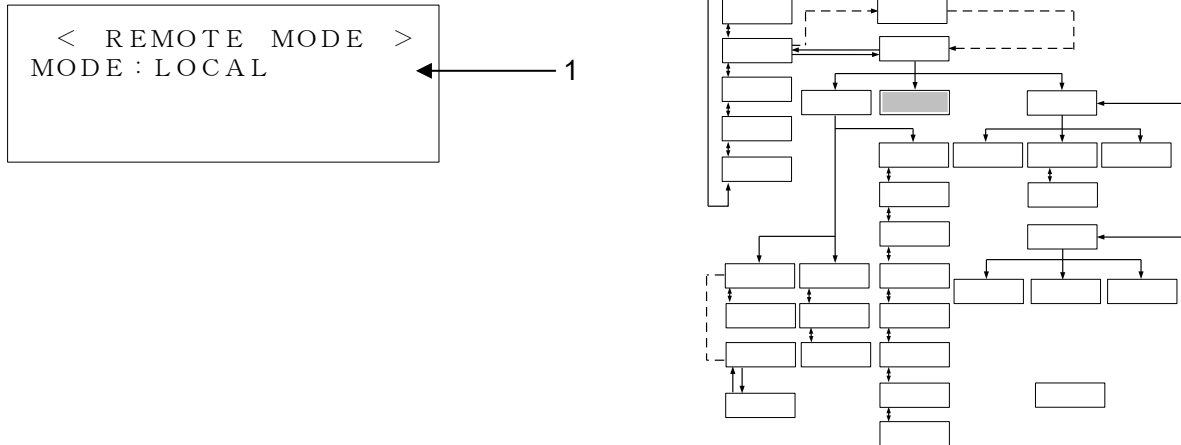

Figure 5-27 Mode Selection screen

Table 5-24 Mode Selection screen

No.	Item	Descriptions	Setting Range	Factory Default
1	MODE	<p>Allows the selection of communication mode.</p> <p>LOCAL : System start/stop and TEMP SP value setting are available only from the operation display panel.</p> <p>DIO REMOTE : System start/stop is allowed only through contact signal. When Analog Communication option is provided, TEMP SP value setting is available through analog signal.</p> <p>SER REMOTE : System start/stop and TEMP SP value setting are available only through serial RS-485 communication.</p> <p>DNET REMOTE^{*1} : System start/stop and TEMP SP value setting are available only through Device Net communication.</p>	<p>LOCAL</p> <p>DIO REMOTE</p> <p>SER REMOTE</p> <p>DNET REMOTE^{*1}</p>	<p>LOCAL</p>

[Tips]

It is displayed only if the Device Net Communication (optional) is provided (*1).

[▲] or [▼] key is used for selecting “Item” And pressing the [ENT] key enabling to select the setting.

5.3.25 Maintenance screen 1

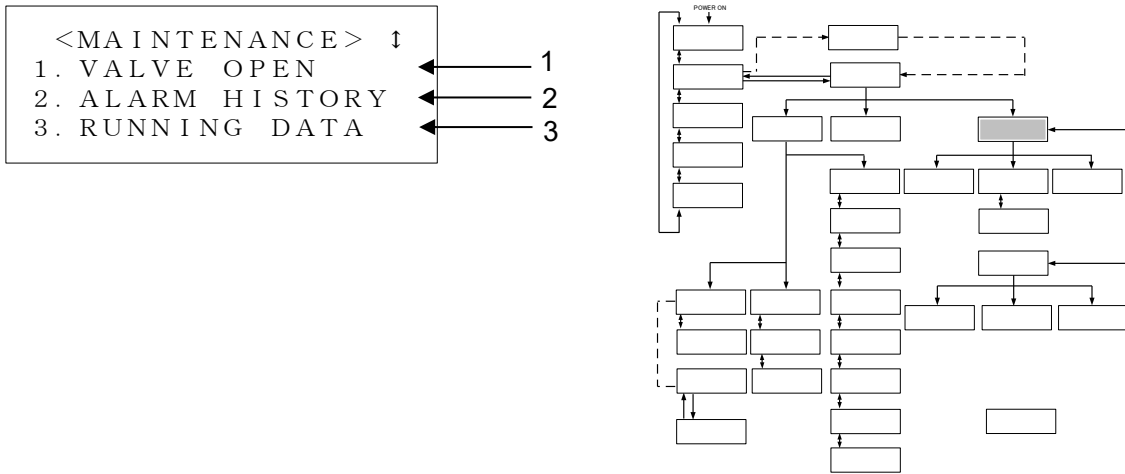

Figure 5-28 Maintenance screen 1

Table 5-25 Maintenance screen 1

No.	Item	Descriptions
1	VALVE OPEN	Switches to the “Maintenance Item screen 3” with the press of the [ENT] key.
2	ALARM HISTORY	Switches to the “Maintenance Item screen 4” with the press of the [ENT] key.
3	RUNNING DATA	Switches to the “Maintenance Item screen 5” with the press of the [ENT] key.

[Tips]

[▲] or [▼] key is used for selecting “Item” and move to other Maintenance screens. And pressing the [ENT] key enabling to change the setting or set value.

5.3.26 Maintenance screen 2

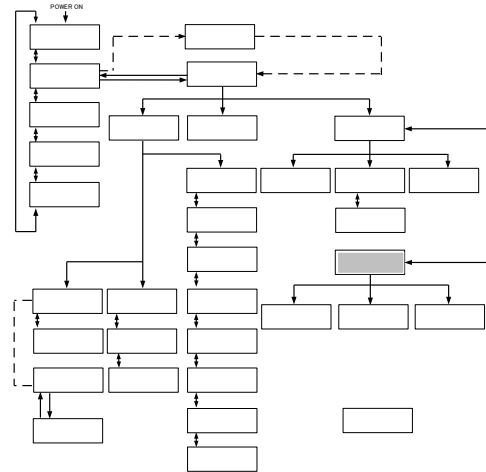

Figure 5-29 Maintenance screen 2

Table 5-26 Maintenance screen 2

No.	Item	Descriptions
1	MONITOR	Switches to the “Maintenance Item screen 6” with the press of the [ENT] key.
2	AUTO PURGE*1	Switches to the “Maintenance Item screen 7” with the press of the [ENT] key.
3	DI ACC RESET*2	Switches to the “Maintenance Item screen 8” with the press of the [ENT] key.

[Tips]

It is displayed only if the Circulating Fluid Automatic Collector (optional) is provided (*1).

It is displayed only if the DI Control Kit (optional) is provided (*2).

[▲] or [▼] key is used for selecting “Item.” and move to other Maintenance screens. And pressing the [ENT] key enabling to change the setting or set value.

5.3.27 Maintenance screen 3

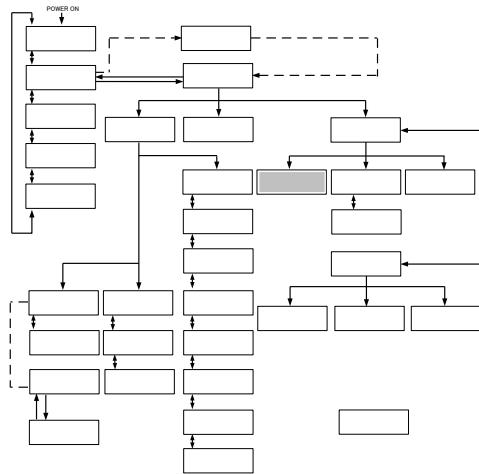
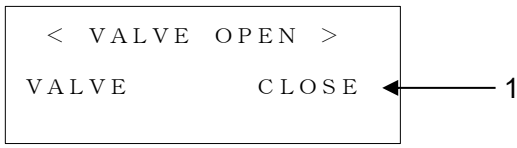

Figure 5-30 Maintenance screen 3

Table 5-27 Maintenance screen 3

No.	Item	Descriptions
1	VALVE	The solenoid valve for DI circuit is opened forcefully.
		The solenoid valve for DI circuit is closed forcefully.

[Tips]

It is displayed only if the DI Control Kit (optional) is provided.
 For other options, "N/A" is displayed on the screen.
 If you move the screen from "Maintenance screen 3",
 The forced operation of the solenoid valve will be canceled.

5.3.28 Maintenance screen 4

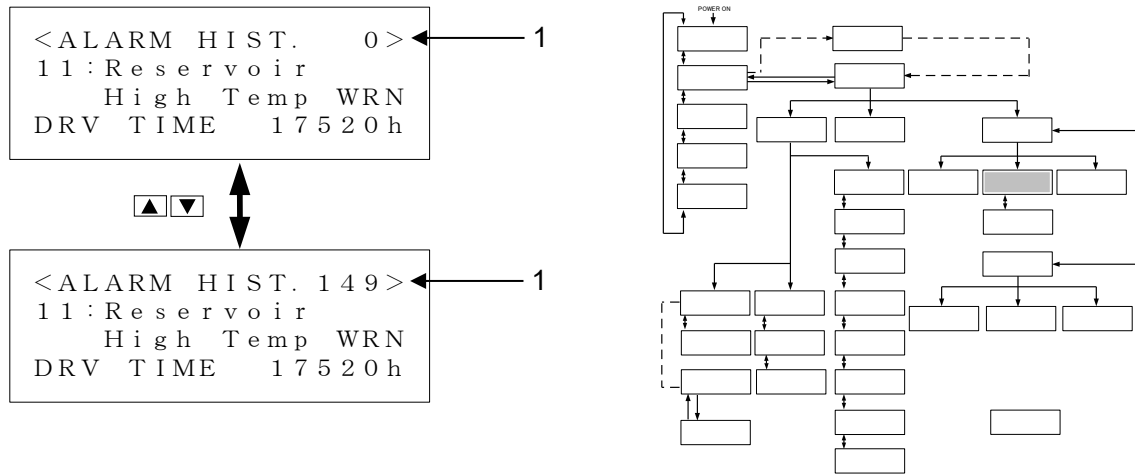

Figure 5-31 Maintenance screen 4

Table 5-28 Maintenance screen 4

No.	Item	Descriptions
1	ALARM HIST	Data recording stores up to 150 pieces of alarm history data. If there are 150 or more pieces of data, the alarm history data is to be deleted in order of longest stores.

5.3.29 Maintenance screen 5

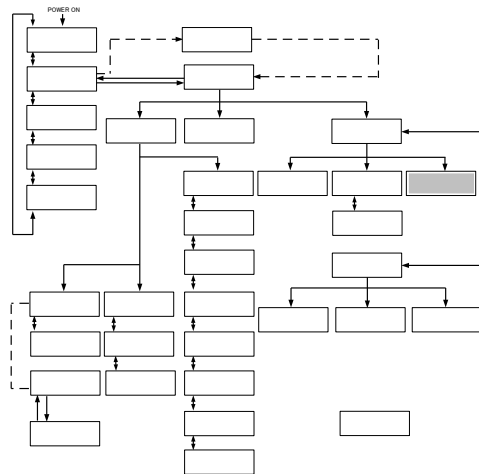
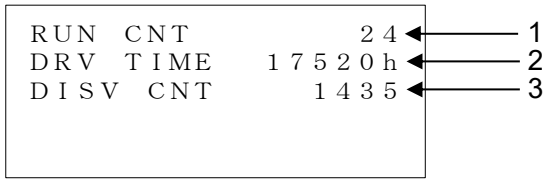

Figure 5-32 Maintenance screen 5

Table 5-29 Maintenance screen 5

No.	Item	Descriptions
1	RUN CNT	Number of times of operation on the system.
2	DRV TIME	Operating time on the system.
3	DISV CNT*1	Number of times that the solenoid valve for DI circuit is activated.

[Tips]

*1 It is displayed only if the DI Control Kit (optional) is provided.
 For other options, "N/A" is displayed on the screen.
 If you move the screen from "Maintenance screen 3",
 The forced operation of the solenoid valve will be canceled.

5.3.30 Maintenance screen 6

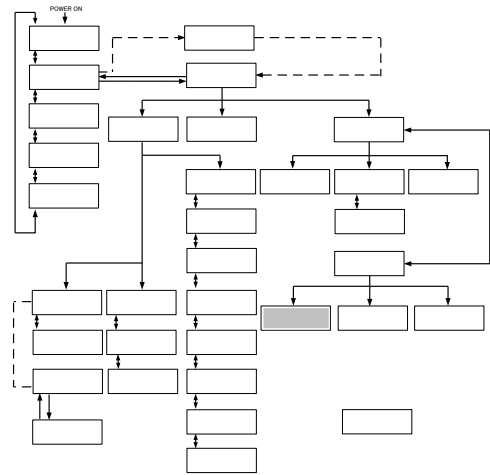
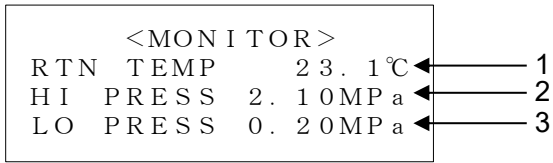

Figure 5-33 Maintenance screen 6

Table 5-30 Maintenance screen 6

No.	Item	Descriptions
1	RTN TEMP	Return temperature of circulating fluid.
2	HI PRESS	High pressure of refrigerant circuit.
3	LOW PRESS	Low pressure of refrigerant circuit.

5.3.31 Maintenance screen 7

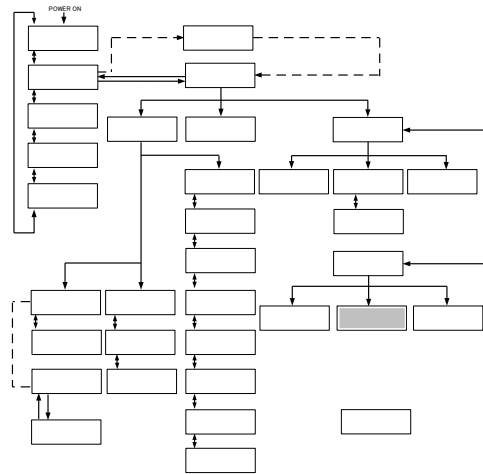

Figure 5-34 Maintenance screen 7

When MSG is “READY”, Start/Stop of circulating fluid automatic collection is available.

Table 5-31 Maintenance screen 7

No.	Item	Descriptions
1	MSG	Indicates the status of circulating fluid automatic collection. READY : Ready to collect. PURGE START : During collection. FINISH : Collection finished normally. TIME OUT : Collecting time exceeds setting value. IN RUNNING : This system during operation. ALARM : Alarm raised to this system. TEMP OUT : Circulating fluid temp. is out of range for starting collection.
2	PURGE TIME	Setting value of PURGE TIME.
3	PURGE MODE	Start/Stop circulating fluid automatic collection. After pressing [ENT] key, pressing either [▲] or [▼] key to select Start/Stop. Then automatic collection Start/Stop is available after pressing [ENT] key to fix the setting. START : Start collection. STOP : Stop collection.

[Tips]

It is displayed only if the Circulating Fluid Automatic Collector (optional) is provided.

5.3.32 Maintenance screen 8

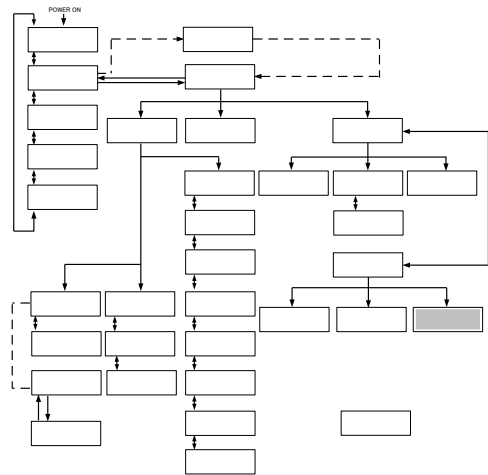
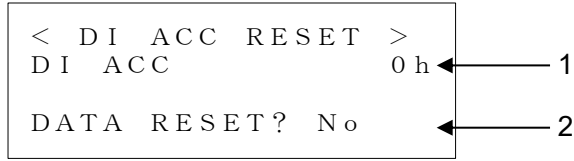

Figure 5-35 Maintenance screen 8

Table 5-32 Maintenance screen 8

No.	Item	Descriptions
1	DI ACC	Accumulated time that the solenoid valve for DI circuit is activated.
2	DATA RESET?	Allows to reset DI ACC. After pressing [ENT] key, pressing either [▲] or [▼] key to select Yes/No. Then Reset/Not reset DI ACC after pressing [ENT] key to fix the setting. Yes : Reset DI ACC. No : Not reset DI ACC.

[Tips]

It is displayed only if the DI Control Kit (optional) is provided.

5.3.33 System Information screen

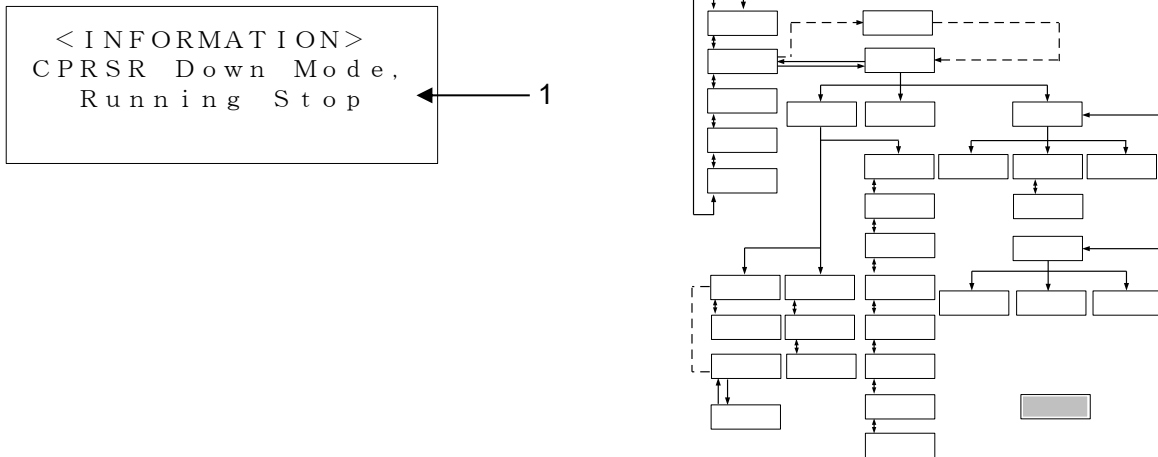

Figure 5-36 System Information screen

The “System Information screen”, as shown above, may be displayed upon system Start/Stop.

Table 5-33 System Information screen

No.	Item	Descriptions
1	INITIALIZE MODE (CONTROL VALVE) (RESERVOIR)	Operation preparation mode after turn-On the main breaker. System operation is disabled if this message is displayed. CONTROL VALVE : Positioning of the electronic expansion valve is performed. RESERVOIR : The circulating fluid flows in this system through the internal pump.
	Pump Up Mode Running Start	If your piping is supplied with an insufficient amount of the circulating fluid at system startup, the circulating pump in this system activated (repeating ON/OFF) to replenish piping with the circulating fluid. Continuous operation is initiated once piping is replenished with the fluid.
	CPRSR Down Mode. Running Stop	Compressor operation remains for approx. 20 seconds after circulating pump stop for the protection of the compressor at the time of system shutdown.

5.4 Examples of System Operation

5.4.1 Example 1: Circulating fluid set temperature is changed from 20.0 deg C to 34.1 deg C.

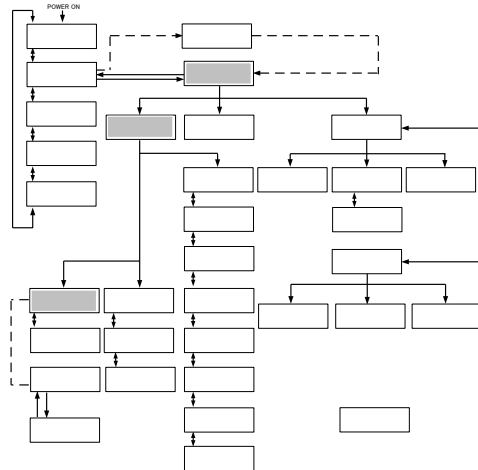

Figure 5-37 Change of Set Temperature from 20 deg C to 34.1 deg C

1. Press the [SEL] key to display the "Menu screen".

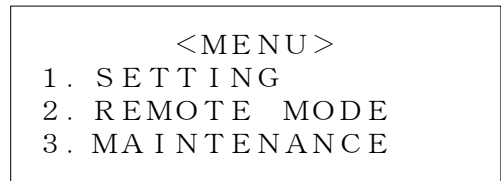

Figure 5-38 Menu screen

2. With the use of the arrow keys ([▲], [▼]), move the cursor to "1. SETTING" and press the [ENT] key.

The "Setting screen" is displayed.



Figure 5-39 Setting screen

3. With the use of the arrow keys ([▲], [▼]), move the cursor to "1. CONTROL SET" and press the [ENT] key.

The "Control Setting screen 1" is displayed.

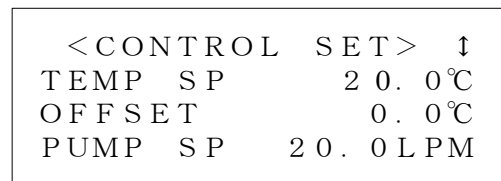

Figure 5-40 Control setting screen1

4. Press the [ENT] key.

The cursor is now appear on the current value for TEMP SP, which enables change of the temperature set value.

```
<CONTROL SET> ↑  
TEMP SP      █20.0°C  
OFFSET       0.0°C  
PUMP SP      20.0LPM
```

Figure 5-41 Control Setting screen 1 : Cursor Display

5. Use the arrow keys ([▲], [▼], [▶]) to change the temperature to 34.1 deg C.

[▲] key: Used to add one value on which the cursor is placed.

[▼] key: Used to subtract one value on which the cursor is placed.

[▶] key: Used to move the cursor to the right.

```
<CONTROL SET> ↑  
TEMP SP      34.█°C  
OFFSET       0.0°C  
PUMP SP      20.0LPM
```

Figure 5-42 Control Setting screen 1 : Change of set value

6. Press the [SEL] key to display the “Menu screen 1”.

```
<CONTROL SET> ↑  
TEMP SP      34.1°C  
OFFSET       0.0°C  
PUMP SP      20.0LPM
```

Figure 5-43 Control Setting screen 1 : Setting Confirmation

5.4.2 Example 2: Communication mode is switched from “LOCAL” to “SER REMOTE”.

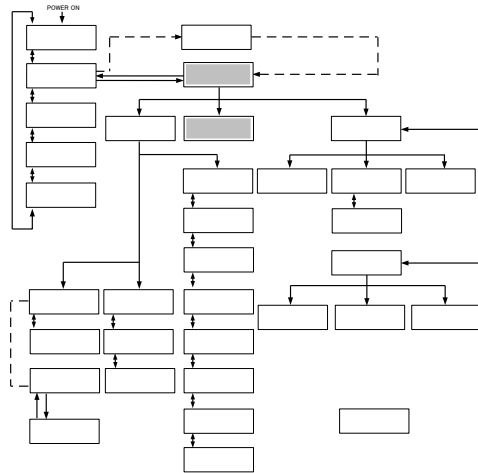

Figure 5-44 Switching of communication mode from “LOCAL” to “SER REMOTE”

1. Press the [SEL] key to display the “Menu screen”.

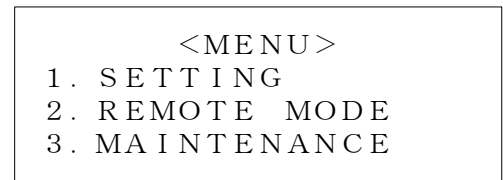

Figure 5-45 Menu screen

2. With the use of the arrow keys ([▲], [▼]), move the cursor to “2. REMOTE MODE” and press the [ENT] key.

The “Mode Selection screen” is displayed.



Figure 5-46 Mode Selection screen

3. Press the [ENT] key

The name of current mode “LOCAL” flashes and enable to switch the setting.



Figure 5-47 Mode Selection screen

4. Use the arrow keys ([▲], [▼]), to select “SER REMOTE”.

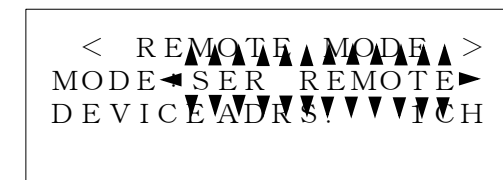

Figure 5-48 Mode Selection screen

5. Press the [ENT]key.

5.4.3 Example 3: PUMP IV is switched from “FLOW” to “FREQ”.

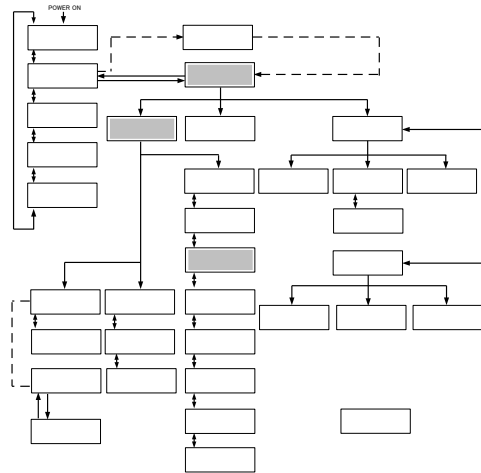

Figure 5-49 Switching of pump operation from FLOW to FREQ

1. Press the [SEL] key to display the “Menu screen”.

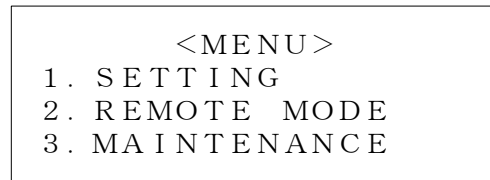

Figure 5-50 Menu screen

2. With the use of the arrow keys ([▲], [▼]), move the cursor to “1.SETTING” and press the [ENT] key.

The “Setting screen” is displayed.



Figure 5-51 Setting screen

3. With the use of the arrow keys ([▲], [▼]), move the cursor to “3.INITIAL SET” and press the [ENT] key.

The “Initial setting screen 1” is displayed.

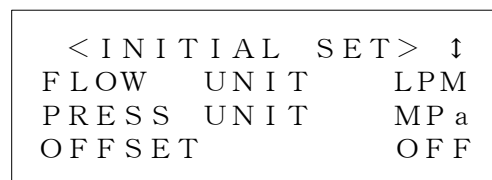

Figure 5-52 Initial Setting screen 1

4. With the use of the arrow keys ([▲],[▼]), Move the cursor to “Initial Setting screen 3”.

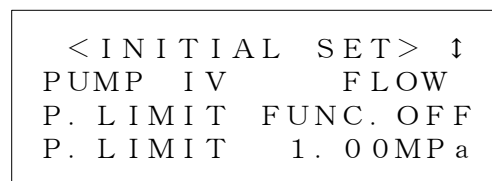

Figure 5-53 Initial Setting screen 3

- 5.** With the use of the arrow keys([▲],[▼]), move the cursor to“PUMP IV”and press the [ENT]key. The name of current setting “FLOW” flashes and enable to switch the setting.

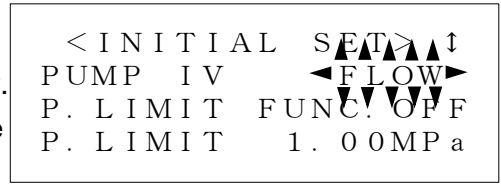

Figure 5-54 Initial Setting screen 3

- 6.** With the use of the arrow keys([▲],[▼]), to select “FREQ”



Figure 5-55 Initial Setting screen 3

- 7.** Press the [ENT] key.

Chapter 6 Error Message and Troubleshooting

6.1 Error Message

The following are to be performed in the event of an error in this system.

- The “ALARM” lamp comes on.
- Alarm buzzer comes on.
- The “Alarm Display screen” is displayed on the LCD screen.
- Error signal is issued through external communication.
(See section 8.1.6 “Communication specification” in Chapter 8 Appendix for details.) on page 8-16
- This system is brought to a stop forcefully according to error types.

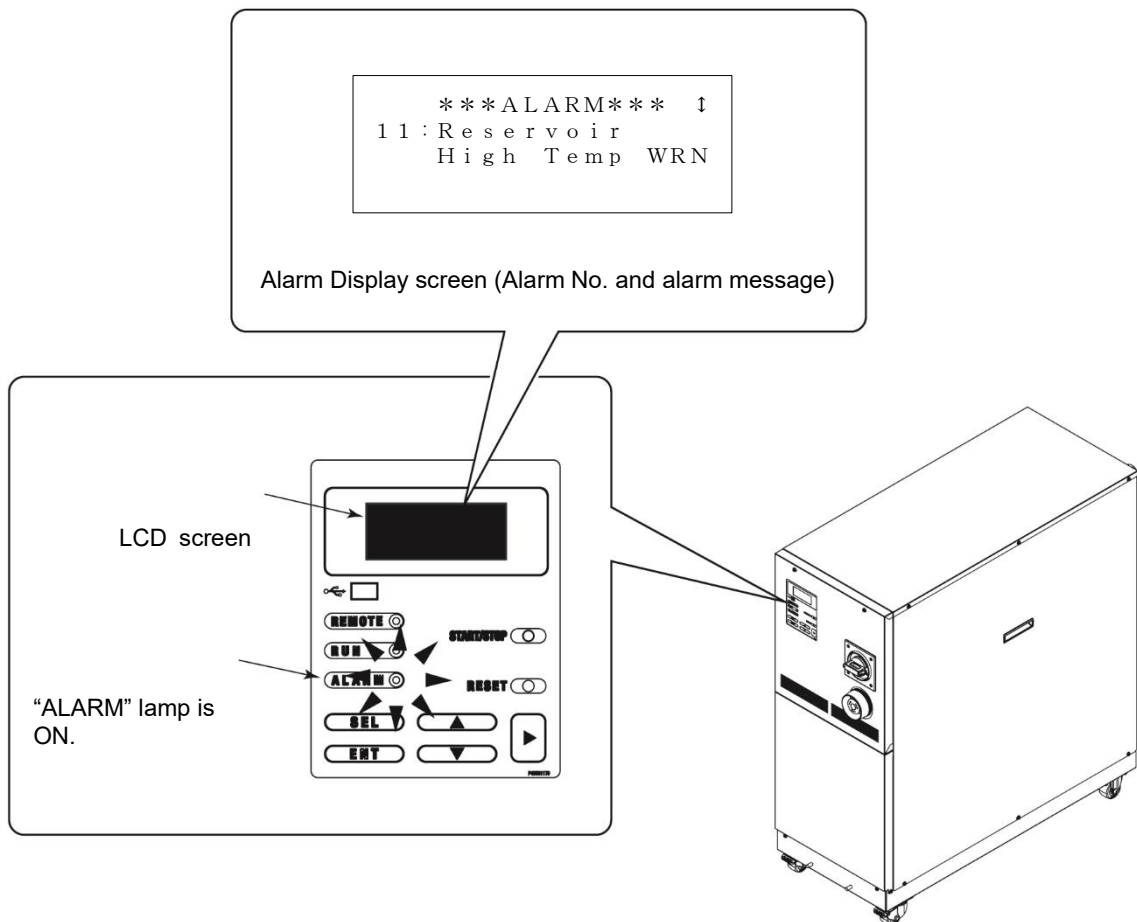

Figure 6-1 Error Occurrence

6.2 Troubleshooting

The procedure for error recovery varies with alarm types.

- Alarm Code.01 to 21,24,25,28,29,32:
Eliminate the error cause. Press the [RESET] key on the operation display panel or power cycle the main breaker to enable error recovery to take effect.
*Alarm code 02 and 16 are alarms only for HRZ008-L/L1-F.
*Alarm code 28 is an alarm only for HRZ010-W*S-F.
- Alarm Code.22:
Eliminate the error cause, and power cycle the main breaker to enable error recovery to take effect.
- Alarm Code.23:
Automatic error recovery is implemented upon elimination of the error.
- Alarm Code.24:
This is an alarm for accessories (optional).
No alarm of this type is issued if the system is outfitted with no accessories.

Table 6-1 Troubleshooting (1/3)

Code	Error message	System condition	Cause	Remedies
01	Water Leak Detect FLT	Stop	The fluid is pooled at the base of this system.	Check for fluid leak.
02	Incorrect Phase Error FLT	Stop	The power phase rotation is wrong.	Check that a proper connection is established between the power cable and main breaker of this system.
03	RFGT High Press FLT	Stop	The pressure of the refrigerant circuit exceeded the specified value. <Specified value> HRZ***-WS/W1S/W2S-F: 3.0MPa HRZ008-L/L1-F:2.4MPa	Check that facility water is being supplied to this system.
04	CPRSR Overheat FLT	Stop	The temperature in the compressor was excessive. <Specified value> HRZ***-WS/W1S/W2S-F: 110 deg C HRZ008-L/L1-F:110 deg C	Check that facility water is being supplied to this system.
05	Reservoir Low Level FLT	Stop	An insufficient amount of the circulating fluid is observed in the tank.	Replenish the circulating fluid.
06	Reservoir Low Level WRN	Continued	An insufficient amount of the circulating fluid is observed in the tank.	Replenish the circulating fluid.
07	Reservoir High Level WRN	Continued	An excessive amount of the circulating fluid is observed in the tank.	Drain the circulating fluid.
08	Temp. Fuse Cutout FLT	Stop	The circulating fluid tank was raised in temperature. <Specified value> Thermal fuse cutout temperature : 98 deg C	Check the load specification. Replacement of the thermal fuse is required. Call the supplier for service.
09	Reservoir High Temp. FLT	Stop	The temperature of the circulating fluid exceeded the specified value. <Specified value> HRZ***-WS/W1S-F : 95 deg C HRZ***-W2S-F : 65 deg C HRZ008-L/L1-F : 50 deg C	Check the load specification.

Table 6-1 Troubleshooting (2/3)

Code	Error message	System condition	Cause	Remedies
10	Return High Temp WRN	Continued	The temperature of the circulating fluid exceeded the specified value. <Specified value> HRZ***-WS-F : 110 deg C HRZ***-W1S-F:100 deg C HRZ***-W2S-F:80 deg C HRZ008-L/L1-F :60 deg C	Check the circulating fluid flow rate, load specification.
11	Reservoir High Temp. WRN	Continued	The temperature of the circulating fluid exceeded your set value. <Setting range> HRZ002-WS/W1S-F : -10.0 to 93.0 deg C HRZ004/008/010-WS/W1S-F : -20.0 to 93.0 deg C HRZ***-W2S-F : 10.0 to 63.0 deg C HRZ008-L/L1-F : -20.0 to 45.0 deg C <Factory default> HRZ***-WS/W1S-F :93.0 deg C HRZ***-W2S-F :63.0 deg C HRZ008-L/L1-F :45.0 deg C	Reset the setting temperature.
12	Return Low Flow FLT	Stop	The flow rate of the circulating fluid falls below specified value. <Specified value> 6L/min	<ul style="list-style-type: none"> • Check that the external valve is opened. • Prepare a thicker external pipe or install bypass piping.
13	Return Low Flow WRN	Continued	The flow rate of the circulating fluid falls below your set value. <Specified value> HRZ***-WS/W1S/W2S-F : 8.0~40.0L/min (2.1~10.6GPM) HRZ008-L-F : 15.0~40.0L/min (4.0~10.6GPM) HRZ008-L1-F : 8.0~40.0L/min (2.1~10.6GPM) <Factory default> HRZ***-WS/W1S/W2S-F : 8.0L/min (2.1GPM) HRZ008-L-F : 15.0L/min (4.0GPM) HRZ008-L1-F : 8.0L/min (2.1GPM)	Reset the setting flow rate.
16	CPRSR Breaker Trip FLT	Stop	The breaker for the compressor power line was tripped.	Check that the power supply to this system is compliant with the specification.
19	FAN Motor Stop WRN	Continued	The ventilating fan came to a stop.	Check that the air vent on the back of the system is not blocked off.
20	Internal Pump Time Out WRN	Continued	The internal pump was under conditions of continuous operation over a specified time. <Specified time>10min	Check for fluid leak from circulating fluid piping in your system.
21	Controller Error FLT	Stop	An error was detected in the control system.	Contact the system supplier for request of inspection and repair.

Chapter 6 Error Message and Troubleshooting

Table 6-1 Troubleshooting (3/3)

Code	Error message	System condition	Cause	Remedies
22	Memory Data Error FLT	Stop	An error was detected in data stored in the controller of this system.	<ul style="list-style-type: none"> Re-turn ON the main breaker to recover from the error. Contact the system supplier for request of inspection and repair.
23	Communication Error	0001	An interruption of serial communication occurred in this system.	Contact the system supplier for request of inspection and repair.
		8000	An interruption of serial communication occurred between this system and your system.	Check for disconnection of the communication connector from this system.
24	DI Low Level WRN	Continued	The DI level of the re-circulating liquid lowered than the your set value (Optional). <Setting range> 0.0 to 2.0MΩ <Factory default> 0.0MΩ	<ul style="list-style-type: none"> Lower the setting for resistivity. Replacement of the DI filter is required
25	Pump Inverter Error FLT	Stop	An error was detected in the inverter for circulating pump.	Contact the system supplier for request of inspection and repair.
28	CPRSR INV Error FLT	Stop	An error was detected in the inverter for compressor.	Contact the system supplier for request of inspection and repair.
29	RFGT Low Press FLT	Stop	The refrigerant pressure falls below the specified value. <Specified value> 0.1MPa	Contact the system supplier for request of inspection and repair.
32	Reservoir Low Temp. WRN	Continued	The temperature of the circulating fluid falls your set value. <Setting range> HRZ002-WS/W1S-F: -15.0 to 90.0 deg C HRZ004/008/010-WS/W1S-F: -25.0 to 90.0 deg C HRZ***-W2S-F: 5.0 to 60.0 deg C HRZ008-L/L1-F: -25.0 to 40.0 deg C <Factory default> HRZ002-WS/W1S-F: -15.0 deg C HRZ004/008/010-WS/W1S-F: -25.0 deg C HRZ***-W2S-F: 5.0 deg C HRZ008-L/L1-F: -25.0 deg C	Reset the setting temperature.

Chapter 7 System Maintenance

7.1 Water Quality Management

⚠ CAUTION



Only designated circulating fluid is permitted to use for this system. Potential system failure and fluid leak may occur if disregarded, which results in electric shock, ground fault, and freeze. Be sure to use fresh water (tap water) compliant with water quality standards in the table below for ethylene glycol aqueous solution and facility water.

Table 7-1 Water Quality Standards for Fresh Water (Tap Water)

	Substance	Facility water spec.	Circulating water spec.
Standards	pH (25 deg C)	6.5 to 8.2	6.0 to 8.0
	Electrical conductivity (25 deg C) (µs/cm) *Circulating fluid 1 to 500	100 to 800	0.5 to 300
	Chloride ion (mgCl ⁻ /L)	Max. 200	Max.50
	Sulfate ion (mgSO ₄ ²⁻ /L)	Max.200	Max.50
	Acid consumption (pH4.8) (mgCaCO ₃ /L)	Max.100	Max.50
	Total hardness (mgCaCO ₃ /L)	Max.200	Max.70
	Calcium hardness (mgCaCO ₃ /L)	Max.150	Max.50
	Ionic silica (mgSiO ₂ /L)	Max.50	Max.30
	Iron (mgFe/L)	Max.1.0	Max.0.3
	Copper (mgCu/L)	Max.0.3	Max.0.1
	Sulfide ion (mgS ²⁻ /L)	Not be detected	
	Ammonium ion (mgNH ₄ ⁺ /L)	Max.1.0	Max.0.1
	Residual chlorine (mgCl/L)	Max.0.3	Max.0.3
	Free carbon dioxide (mgCO ₂ /L)	Max.4.0	Max.4.0
	Filtering (µm)	Max.5	

* According to the Water quality guideline for refrigeration air-conditioning equipment: JRA-GL-02-1994

⚠ CAUTION



If the periodic inspection finds a nonconforming substance in the facility water, clean the facility water circuit and recheck the quality of the facility water.

7.2 Inspection and Cleaning

⚠ WARNING



- Do not touch any electrical parts with wet hands. Keep wet hands away from electrical parts. Potential electric shock can occur if disregarded.
- Keep this system from water. Potential electric shock or fire can occur if disregarded.

⚠ WARNING



If the inspection and cleaning require the removal of the panel, be sure to re-attach the panel upon completion. Potential personal injury or electric shock may occur if operated with the panel opened or removed.

7.2.1 Daily inspection

Table 7-2 Daily Inspection

Inspection item	Inspection method	
Installation condition	Check of the condition of system installation	No heavy object is placed on this system. This system should not be subjected to external force.
		Temperature and humidity fall within the specified range.
Fluid leak	Check of the piping connector section	No leak of facility water and circulating fluid from the piping connector section
Fluid level	Reading of the level of the circulating fluid	Level falls within the circulating fluid specified level between “High” and “Low”.
Operation display panel	Display check	Clarity of letters and numbers on the LCD display should be assured.
	Function check	[RUN] lamp is ON.
Circulating fluid temperature	Confirm the reading on the LCD screen	Temperature should be within setpoint.
Refrigerant pressure	Reading of the refrigerant pressure gauge	Value of “HI PRESS” in “Maintenance screen 6 (page 5-33) ” should be in the following range. HRZ010-W*S-F : 0.5 to 2.5 MPa HRZ008-L/L1-F : 0.5 to 2.0 MPa
Discharge pressure of circulating fluid	Confirm the reading on the LCD screen	Reading should not have deviated much from last inspection.
Circulating fluid flow rate	Confirm the reading on the LCD screen	Reading should not have deviated much from last inspection.
Operating condition	Operating condition check	No abnormal noise, vibration, odor and smoke
Facility water	Check of the facility water	Temperature, flow rate and pressure fall within the specified range.
Circulating fluid supply port cap	Check by providing manual tightening	No looseness

7.2.2 Quarterly inspection



⚠ WARNING	
	<p>Quarterly inspection requires an advance lockout/tagout of this system. See section 1.5.3 “Lockout/Tagout” in “Chapter 1 Safety” for details on page 1-10.</p>

Table 7-3 Quarterly Inspection

Inspection item	Inspection method
Circulating fluid	Circulating fluid is to be drained for check. Fluid should be free of particles, moisture ^{*1} and foreign substances.
	For ethylene glycol solution, confirm that the concentration falls within the specified range.
	Recommended to replace the water.
Facility water	Facility water quality should fall within the standards specified.
Ventilation hole and electrical parts	No particles and dust should be present.

CAUTION	
	<p>Moisture trapped in the fluorinated fluid (*1) freezes in the heat exchanger element and piping, which may lead to system failure.</p>

7.3 Storage

The following should be performed for system long-term storage.

- 1.** Drain the circulating fluid. See section 7.3.1 “Draining of circulating fluid out of tank” for details on page 7-4.
- 2.** Drain the facility water. See section 7.3.2 “Draining of facility water” for details on page 7-5.
- 3.** Cover the system with a plastic sheet for storage.

7.3.1 Draining of circulating fluid out of tank

CAUTION



- Use the clean container for circulating fluid recovery. Reuse of the recovered circulating fluid with contaminated will cause insufficient cooling and system failure
- Be sure to wait until the circulating fluid obtains room temperature for its draining. Potential burns and dew intrusion may occur if disregarded.

1. Prepare the container for circulating fluid recovery at the back of this system.

2. Connect the drain hoses to the main and sub tank drain ports each. Insert the tip of the hose into the container.

- Prepare a drain hose (Rc3/8-diameter) on your responsibility.

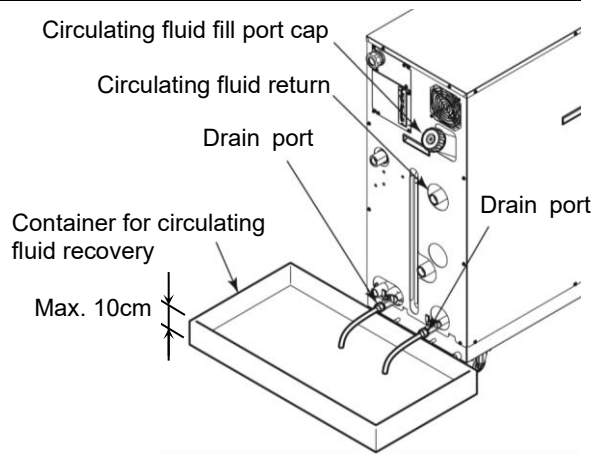



Figure 7-1 Container for Circulating Fluid Recovery

3. Remove the cap of the circulating fluid fill port.

4. Open the valves of the main and sub tank drain ports to drain the circulating fluid.

5. Apply air purge from the the circulating fluid return to push the circulating fluid remaining in the heat exchange back in the tank and drain it.

CAUTION



If the recovered circulating fluid is contaminated by foreign substances, completely remove them. Do not reuse contaminated fluid. Potential insufficient cooling, system failure and froth in the circulating fluid may occur if disregarded.

CAUTION



Recovered circulating fluid must be sealed in a container to prevent contamination from moisture or foreign substances. Stored in a cool, dark place. Keep it from flame.

6. Upon completion of fluid draining, close the valves of the main and sub tank drain ports.

7. Add plugs to seal off ports on the rear of this system.

- See section 7.3.2 “Draining of facility water” for plug attachment.

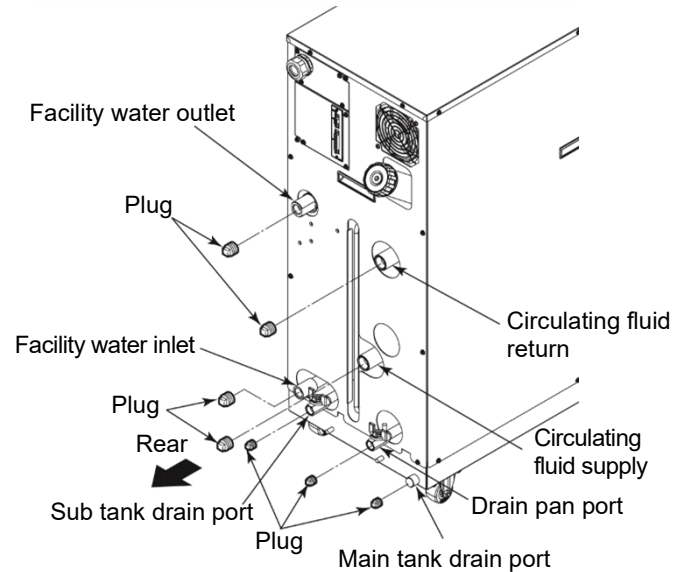

Figure 7-2 Plug Attachment

7.3.2 Draining of facility water

⚠ CAUTION



Be sure to drain the facility water only when it is at room temperature. Trapped fluid inside the system can still be hot. Potential burns can occur if disregarded.

1. Place the drain pan underneath the piping connections on the rear of this system.

- A 7L-capacity or bigger drain pan is required.

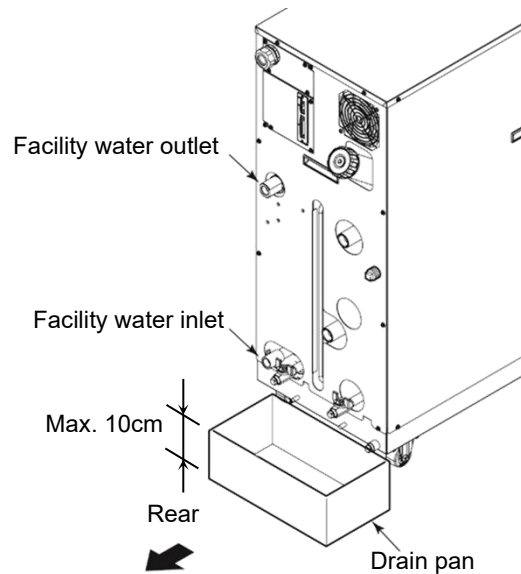

Figure 7-3 Drain Pan Attachment

- 2.** Remove facility water piping.
 - Remove the joints such as unions if present.
-

- 3.** Drain the facility water using the facility water inlet port.

7.4 Periodic Replacement Parts

Replacement of consumables listed in the following table is recommended. Contact the system supplier for request of part replacement.

Table 7-4 Periodic Replacement Part List

Part	Recommended replacement cycle
Internal pump	Every 3 yrs
Circulating pump	Every 3 yrs
Ventilating fan	Every 3 yrs
Inverter Coolong Fan	Every 3 yrs

* Note: A replacement cycle may vary with your usage condition.

Chapter 8 Appendix

8.1 Specification

8.1.1 System specification

■ Specification for fluorinated fluid (wide temperature)

Table 8-1 Specification for Fluorinated Fluid (wide temperature)

Model		HRZ002-WS-F	HRZ004-WS-F	HRZ008-WS-F	HRZ010-WS-F	
Cooling method		Water cooled refrigerant				
Cooling capacity ^{*1} (50Hz/60Hz)	kW	2.0	4.0	8.0	10.0	
Operating temperature range	deg C	-10 to 90	-20 to 90			
Temperature stability	deg C	±0.1 ^{*2}				
Circulating fluid		Galden [®] HT135 ^{*3} Fluorinert [™] FC-3283 ^{*3} (-20 to 40 deg C) Galden [®] HT200 ^{*3} Fluorinert [™] FC-40 ^{*3} (20 to 90 deg C)				
		(No intrusion of foreign body)				
Refrigerant		R410A(HFC,GWP2088) ^{*11}				
Quantity of refrigerant	kg	1.5				
Pump capacity ^{*4}	MPa	0.65 (At 20L/min) (94[PSIG] At 5.3 [gal/min])			0.72 (At 20L/min) (104[PSIG] At 5.3 [gal/min])	
Main Tank capacity ^{*5}	L	Approx.15 (4 [gal])				
Sub Tank capacity ^{*6}	L	Approx.16 (4.2 [gal])				
Circulating fluid port		Rc 3/4				
Facility water		deg C /MPa	10 to 30 / 0.3 to 0.7 (45 to 100 [PSIG])			
Facility water required flow rate	Rated condition ^{*9}	L/min	4	7	14	15
	Temp. changing condition ^{*10}		10	12	15	15
Facility water port		Rc 1/2				
Power supply		3-phase 50/60Hz AC200/200 to 208V±10%				
Breaker size	A	20	30			
Dimensions ^{*7}	mm	W380×D870×H950 (W14.96xD34.25xH37.40[inch])				
Weight ^{*8}	kg	165 (364 [lbs])				
Communication		Serial RS-485 (Dsub-9pin) , Contact signal (Dsub-25pin)				

*1: The capacity is derived under the conditions that the circulating fluid temp is 20 deg C, the facility water temp. is 25 deg C and that the circulating fluid flow rate is obtained at a specified flow rate of pump capacity.

*2: This is a system output temperature, with flow rate defined in pump capacity secured, when stabilized with no disturbance. Its upper limit may be violated if an insufficient amount of the circulating fluid is present or a disturbance to flow rate is observed.

*3: Galden[®] is a registered trademark of Solvay Solexis, and Fluorinert[™] is a trademark of U.S. 3M.

*4: The capacity is derived at the Outlet of this system when the circulating fluid temp. is at 20 deg C and maximum frequency operation by inverter.

*5: This is a minimum amount of the fluid for operation of the Thermo Chiller outfitted with internal piping and heat exchanger in this system. Circulating fluid temp.: 20deg C

*6: For circulating fluid containment during line purge back or back flow. This is the volume of free space in Sub-Tank when fluid level is at "High" level. Main-Tank capacity is excluded.

*7: This is the dimensions of panels, which is derived without protrusions such as a breaker handle.

*8: This is the mass of the system when it contains no circulating fluid.

*9: The required flow rate when the cooling capacity load is applied under the condition in *1.

*10: Temporarily required flow rate when set temperature is changed under the facility water temp.25 deg C.

*11: The value of IPCC (Intergovernmental Panel on Climate Change) Forth Assignment Report : Climate Change 2007 (AR4).

■ Specification for ethylene glycol solution (wide temperature)

Table 8-2 Specification for ethylene glycol solution (wide temperature)

Model		HRZ002-W1S-F	HRZ004-W1S-F	HRZ008-W1S-F	HRZ010-W1S-F
Cooling method		Water cooled refrigerant			
Cooling capacity ^{*1} (50Hz/60Hz)	kW	2.0	4.0	8.0	10.0
Operating temperature range	deg C	-10 to 90	-20 to 90		
Temperature stability	deg C	±0.1 ^{*2}			
Circulating fluid		Ethylene glycol aqueous solution 60% ^{*3}			
		(No intrusion of foreign body)			
Refrigerant		R410A(HFC,GWP2088) ^{**11}			
Quantity of refrigerant	kg	1.5			
Pump capacity ^{*4}	MPa	0.40 (At 20L/min) (58 [PSIG] At 5.3 [gal/min])			
Main Tank capacity ^{*5}	L	Approx.15 (4 [gal])			
Sub Tank capacity ^{*6}	L	Approx.16 (4.2 [gal])			
Circulating fluid port		Rc 3/4			
Facility water	deg C /MPa	10 to 30 / 0.3 to 0.7 (45 to 100 [PSIG])			
Facility water required flow rate	Rated condition ^{*9}	4	6	14	15
	Temp. changing condition ^{*10}	10	12	15	15
Facility water port		Rc 1/2			
Power supply		3-phase 50/60Hz AC200/200 to 208V±10%			
Breaker size	A	20	30		
Dimensions ^{*7}	mm	W380×D870×H950 (W14.96×D34.25×H37.40[inch])			
Weight ^{*8}	kg	165 (364 [lbs])			
Communication		Serial RS-485 (Dsub-9pin) , Contact signal (Dsub-25pin)			

*1: The capacity is derived under the conditions that the circulating fluid temp is 20 deg C, the facility water temp. is 25 deg C and that the circulating fluid flow rate is obtained at a specified flow rate of pump capacity.

*2: This is a system output temperature, with flow rate defined in pump capacity secured, when stabilized with no disturbance. Its upper limit may be violated if an insufficient amount of the circulating fluid is present or a disturbance to flow rate is observed.

*3: Pure ethylene glycol needs dilution with fresh water before use.
Ethylene glycol with additives such as preservatives is NOT available. It not only deteriorates the performance, but also lead to cause failure.

*4: The capacity is derived at the Outlet of this system when the circulating fluid temp. is at 20 deg C and maximum frequency operation by inverter.

*5: This is a minimum amount of the fluid for operation of the Thermo Chiller outfitted with internal piping and heat exchanger in this system. Circulating fluid temp.: 20 deg C

*6: For circulating fluid containment during line purge back or back flow. This is the volume of free space in Sub-Tank when fluid level is at "High" level. Main-Tank capacity is excluded.

*7: This is the dimensions of panels, which is derived without protrusions such as a breaker handle.

*8: This is the mass of the system when it contains no circulating fluid.

*9: The required flow rate when the cooling capacity load is applied under the condition in *1.

*10: Temporarily required flow rate when set temperature is changed under the facility water temp.25 deg C.

*11: The value of IPCC (Intergovernmental Panel on Climate Change) Forth Assignment Report : Climate Change 2007 (AR4).

■ Specification for water (wide temperature)

Table 8-3 Specification for water (wide temperature)

Model		HRZ002-W2S-F	HRZ004-W2S-F	HRZ008-W2S-F	HRZ010-W2S-F
Cooling method		Water cooled refrigerant			
Cooling capacity ^{*1} (50Hz/60Hz)	kW	2.0	4.0	8.0	10.0
Operating temperature range	deg C	10 to 60			
Temperature stability	deg C	±0.1 ^{*2}			
Circulating fluid		Pure water / DI water ^{*3} (No intrusion of foreign body)			
Refrigerant		R410A(HFC,GWP2088) ^{**11}			
Quantity of refrigerant	kg	1.5			
Pump capacity ^{*4}	MPa	0.38 (At 20L/min) (55 [PSIG] At 5.3 [gal/min])			
Main Tank capacity ^{*5}	L	Approx.15 (4 [gal])			
Sub Tank capacity ^{*6}	L	Approx.16 (4.2 [gal])			
Circulating fluid port		Rc 3/4			
Facility water	deg C /MPa	10 to 30 / 0.3 to 0.7 (45 to 100 [PSIG])			
Facility water required flow rate	Rated condition ^{*9}	4	7	14	15
	Temp. changing condition ^{**10}	10	12	15	15
Facility water port		Rc 1/2			
Power supply		3-phase 50/60Hz AC200/200 to 208V±10%			
Breaker size	A	20	30		
Dimensions ^{*7}	mm	W380×D870×H950 (W14.96×D34.25×H37.40[inch])			
Weight ^{*8}	kg	165 (364 [lbs])			
Communication		Serial RS-485 (Dsub-9pin) , Contact signal (Dsub-25pin)			

- *1: The capacity is derived under the conditions that the circulating fluid temp is 20 deg C, the facility water temp. is 25 deg C and that the circulating fluid flow rate is obtained at a specified flow rate of pump capacity.
- *2: This is a system output temperature, with flow rate defined in pump capacity secured, when stabilized with no disturbance. Its upper limit may be violated if an insufficient amount of the circulating fluid is present or a disturbance to flow rate is observed.
- *3: Water quality of The Japan Refrigeration and Air Conditioning Industry Association (JRA GL-02-1994/Recirculating fluid of Cooling water system) shall be satisfied (See "7.1 Water Quality Management")
Additives such as preservative is NOT available. It not only deteriorates the performance, but also lead to cause failure.
- *4: The capacity is derived at the Outlet of this system when the circulating fluid temp. is at 20 deg C and maximum frequency operation by inverter.
- *5: This is a minimum amount of the fluid for operation of the Thermo Chiller outfitted with internal piping and heat exchanger in this system. Circulating fluid temp.: 20 deg C
- *6: For circulating fluid containment during line purge back or back flow. This is the volume of free space in Sub-Tank when fluid level is at "High" level. Main-Tank capacity is excluded.
- *7: This is the dimensions of panels, which is derived without protrusions such as a breaker handle.
- *8: This is the mass of the system when it contains no circulating fluid.
- *9: The required flow rate when the cooling capacity load is applied under the condition in *1.
- *10: Temporarily required flow rate when set temperature is changed under the facility water temp.25 deg C.
- *11: The value of IPCC (Intergovernmental Panel on Climate Change) Forth Assignment Report : Climate Change 2007 (AR4).

■ Specification for fluorinated fluid (low temperature)

Table 8-4 Specification for Fluorinated Fluid (Low Temperature)

Model		HRZ008-L-F
Cooling method		Water cooled refrigerant
Cooling capacity* ¹ (50Hz/60Hz)	kW	8.0 (At -10 deg C)
Operating temperature range	deg C	-20 to 40
Temperature stability	deg C	±0.1* ²
Circulating fluid		Galden® HT135* ³ Fluorinert™ FC-3283* ³
		(No intrusion of foreign body)
Refrigerant		R448A(HFC/HFO,GWP1387)* ¹⁰
Quantity of refrigerant	kg	2
Pump capacity* ⁴ (50Hz/60Hz)	MPa	Max.0.95(At 30l/min) (138 [PSIG] At 8 [gal/min]) with flow control function by VFD
Main Tank capacity* ⁵	L	Approx.22 (5.8 [gal])
Sub Tank capacity* ⁶	L	Approx.17 (4.5 [gal])
Circulating fluid port		Rc 3/4
Facility water	deg C /MPa	10 to 25 / 0.3 to 0.7 (45 to 100 [PSIG])
Required flow of facility water* ⁹ (50Hz/60Hz)	L/min	18 / 23 (4.8 / 6.0 [gal/min])
Facility water port		Rc 1/2
Power supply		3-phase 50/60Hz AC200/200 to 208V±10%
Main breaker size	A	60
Dimensions* ⁷	mm	W415×D1080×H1075 (W16.34xD42.52xH42.32 [inch])
Weight * ⁸	kg	236 (520 [lbs])
Communication		Serial RS-485 (Dsub-9pin), Contact signal (Dsub-25pin)

*1: The capacity is derived under the conditions that the facility water temp. is 25 deg C and that the circulating fluid flow rate is obtained at a specified flow rate of pump capacity. Applied to 50 / 60Hz.

*2: This is a system output temperature, with flow rate defined in pump capacity secured, when stabilized with no disturbance. Its upper limit may be violated if an insufficient amount of the circulating fluid is present or a disturbance to flow rate is observed.

*3: Galden® is a registered trademark of Solvay Solexis, and Fluorinert™ is a trademark of U.S. 3M.

*4: The capacity is derived at the Outlet of this system when the circulating fluid temp. is at 20 deg C.

*5: This is a minimum amount of the fluid for operation of the Thermo Chiller outfitted with internal piping and heat exchanger in this system. Circulating fluid temp.: 20 deg C

*6: For circulating fluid containment during line purge back or back flow. This is the volume of free space in Sub-Tank When fluid level is at "High" level. Main-Tank capacity is excluded.

*7: This is the dimensions of panels, which is derived without protrusions such as a breaker handle.

*8: This is the mass of the system when it contains no circulating fluid.

*9: Facility water temp. is 25 deg C. There is required flow when adding load described on cooling capacity.

*10: The value of IPCC (Intergovernmental Panel on Climate Change) Forth Assignment Report : Climate Change 2007 (AR4).

■ Specification for ethylene glycol solution (low temperature)

Table 8-5 Specification for Ethylene Glycol Aqueous Solution (Low Temperature)

Model		HRZ008-L1-F
Cooling method		Water cooled refrigerant
Cooling capacity ^{*1} (50Hz/60Hz)	kW	8.0 (At -10 deg C)
Operating temperature range	deg C	-20 to 40
Temperature stability	deg C	±0.1 ^{*2}
Circulating fluid		Ethylene glycol solution 60% ^{*3} (No intrusion of foreign body)
Refrigerant		R448A(HFC/HFO,GWP1387) ^{*10}
Quantity of refrigerant	kg	2
Pump capacity ^{*4} (50Hz/60Hz)	MPa	Max.0.40 (At 20L/min) (58 [PSIG] At 5.3 [gal/min]) with flow control function by VFD
Main Tank capacity ^{*5}	L	Approx.22 (5.8 [gal])
Sub Tank capacity ^{*6}	L	Approx.17 (4.5 [gal])
Circulating fluid port		Rc 3/4
Facility water	deg C /MPa	10 to 25 / 0.3 to 0.7 (45 to 100 [PSIG])
Required flow of facility water ^{*9} (50Hz/60Hz)	L/min	18 / 23 (4.8 / 6.0 [gal/min])
Facility water port		Rc 1/2
Power supply		3-phase 50/60Hz AC200/200 to 208V±10%
Main breaker size	A	60
Dimensions ^{*7}	mm	W415xD1080xH1075 (W16.34xD42.52xH42.32 [inch])
Weight ^{*8}	kg	236 (520 [lbs])
Communication		Serial RS-485 (Dsub-9pin) , Contact signal (Dsub-25pin)

*1: The capacity is derived under the conditions that the facility water temp. is 25 deg C and that the circulating fluid flow rate is obtained at a specified flow rate of pump capacity. Applied to 50 / 60Hz.

*2: This is a system output temperature, with flow rate defined in pump capacity secured, when stabilized with no disturbance. Its upper limit may be violated if an insufficient amount of the circulating fluid is present or a disturbance to flow rate is observed.

*3: Pure ethylene glycol needs dilution with fresh water before use.
Ethylene glycol with additives such as preservatives is NOT available.

*4: The capacity is derived at the Outlet of this system when the circulating fluid temp. is at 20 deg C.

*5: This is a minimum amount of the fluid for operation of the Thermo Chiller outfitted with internal piping and heat exchanger in this system. Circulating fluid temp.: 20 deg C

*6: For circulating fluid containment during line purge back or back flow. This is the volume of free space in Sub-Tank When fluid level is at "High" level. Main-Tank capacity is excluded.

*7: This is the dimensions of panels, which is derived without protrusions such as a breaker handle.

*8: This is the mass of the system when it contains no circulating fluid.

*9: Facility water temp. is 25 deg C. There is required flow when adding load described on cooling capacity.

*10: The value of IPCC (Intergovernmental Panel on Climate Change) Forth Assignment Report : Climate Change 2007 (AR4).

8.1.2 Cooling capacity

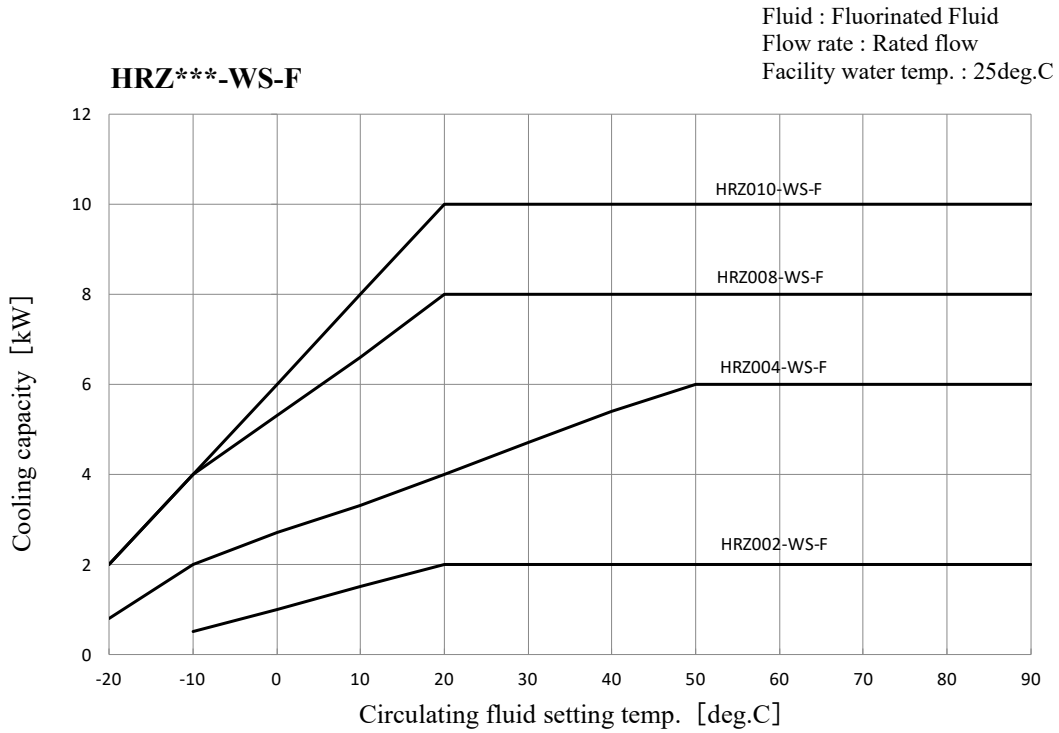

Figure 8-1 Cooling capacity (HRZ***-WS-F)
 *Common to 50/60Hz

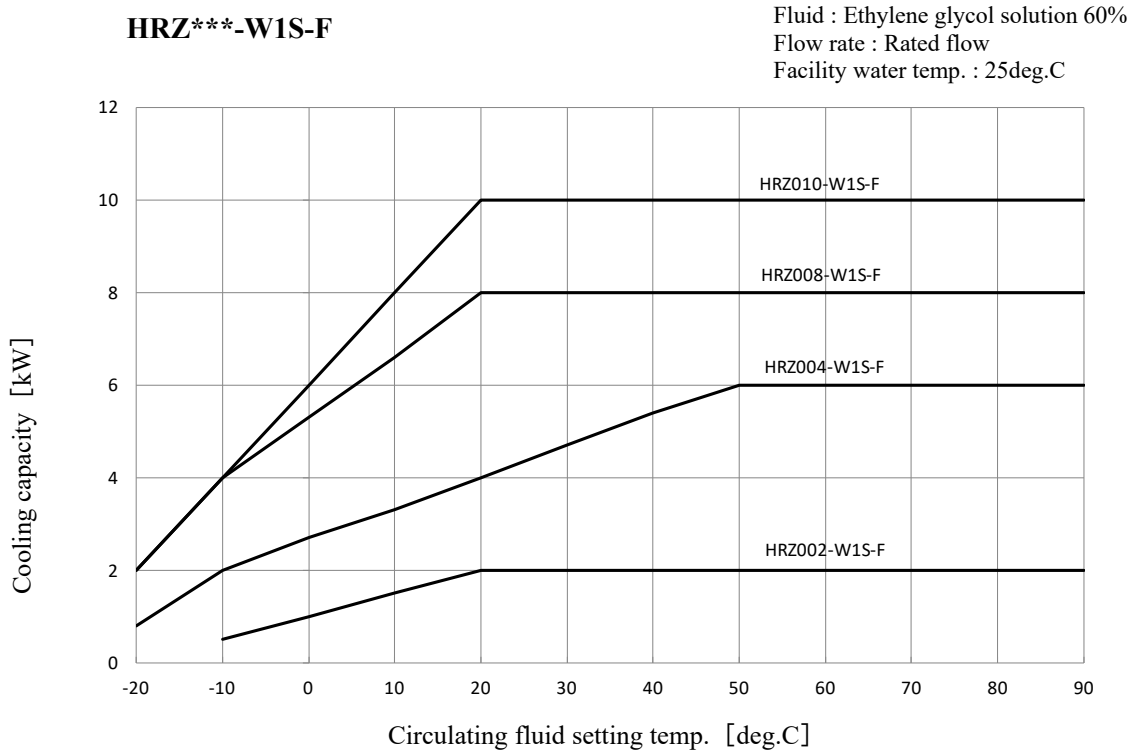

Figure 8-2 Cooling capacity (HRZ***-W1S-F)
 *Common to 50/60Hz

HRZ*-W2S-F**

Fluid : Water
 Flow rate : Rated flow
 Facility water temp. : 25deg.C

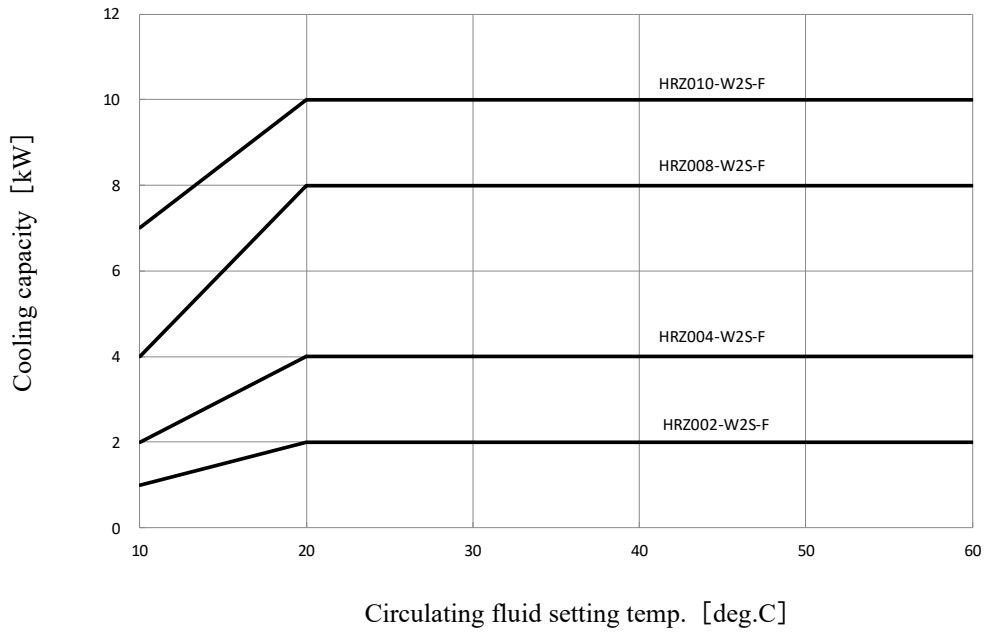

Figure 8-3 Cooling capacity (HRZ***-W2S-F)
 *Common to 50/60Hz

HRZ008-L-F

Fluid : Fluorinated Fluid
 Flow rate : Rated flow
 Facility water temp. : 25deg. C

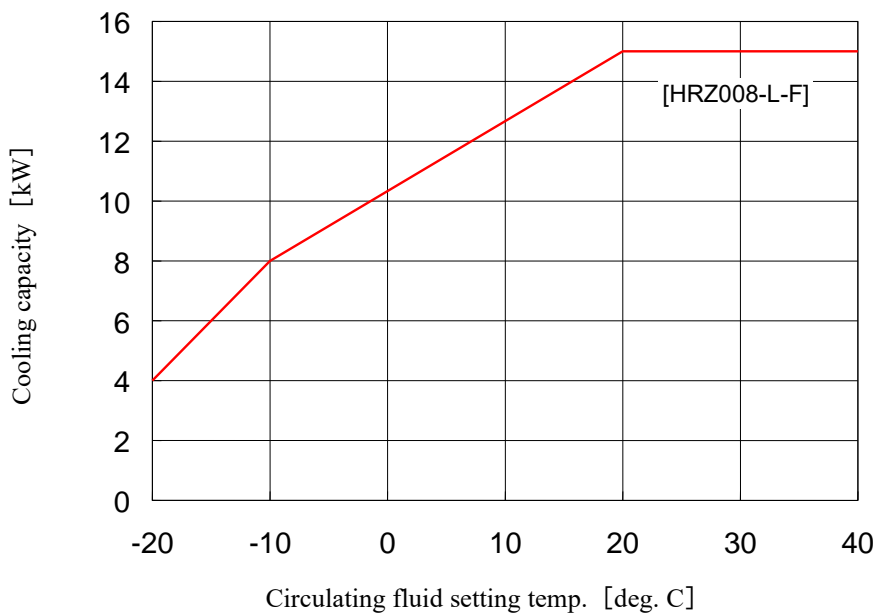

Fig. 8-4 Cooling capacity (HRZ008-L-F)
 *Common to 50/60Hz

HRZ008-L1-F

Fluid : Ethylene glycol solution 60%
Flow rate : Rated flow
Facility water temp. : 25deg. C

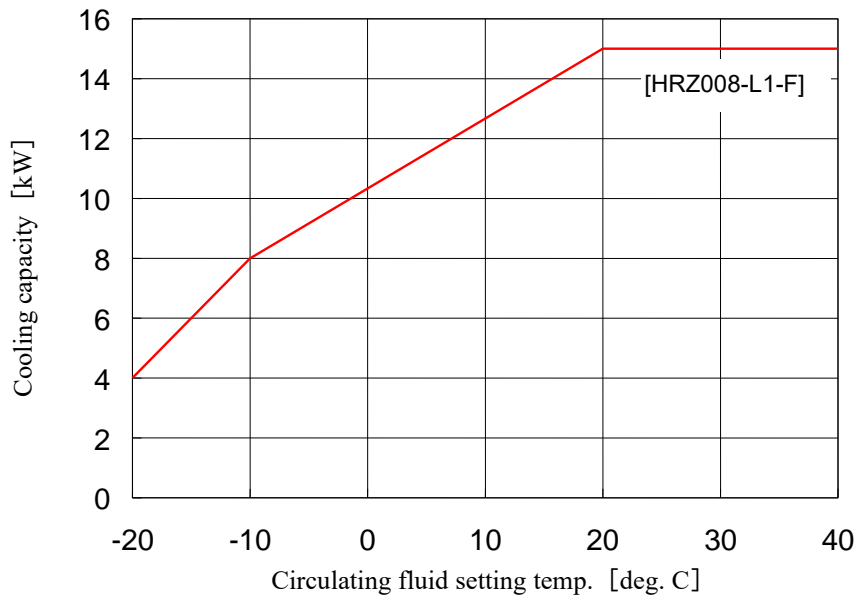

Fig. 8-5 Cooling capacity (HRZ008-L1-F)
*Common to 50/60Hz

8.1.3 Heating capacity

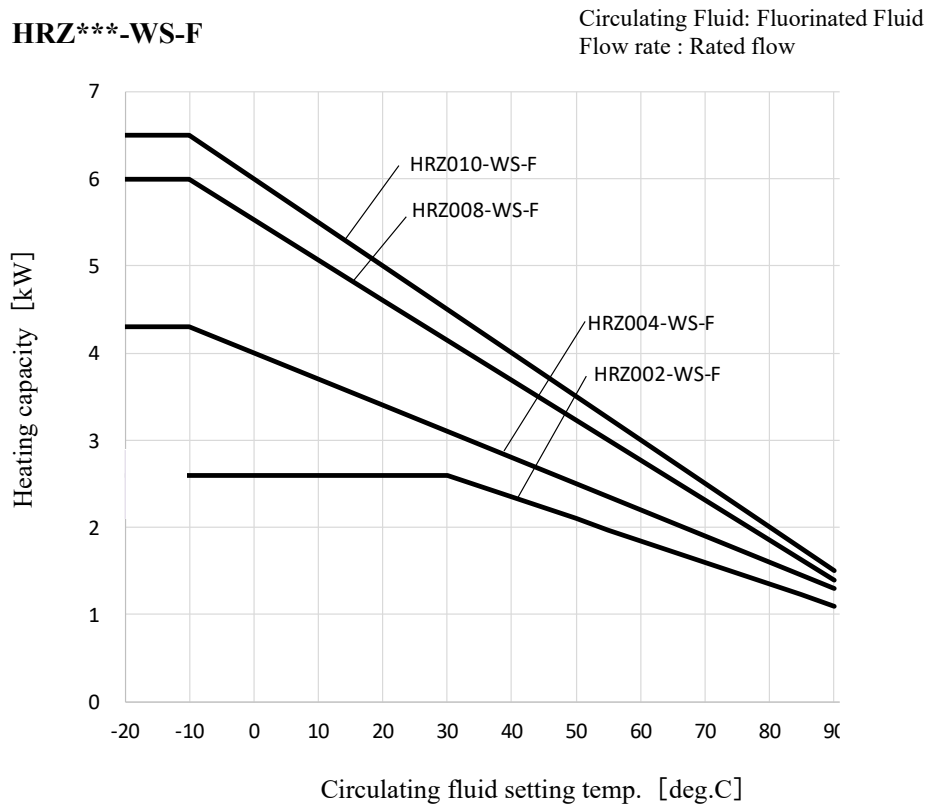

Fig. 8-6 Heating capacity (HRZ***-WS-F)
*When pump inverter is operating at frequency of 60Hz (maximum).

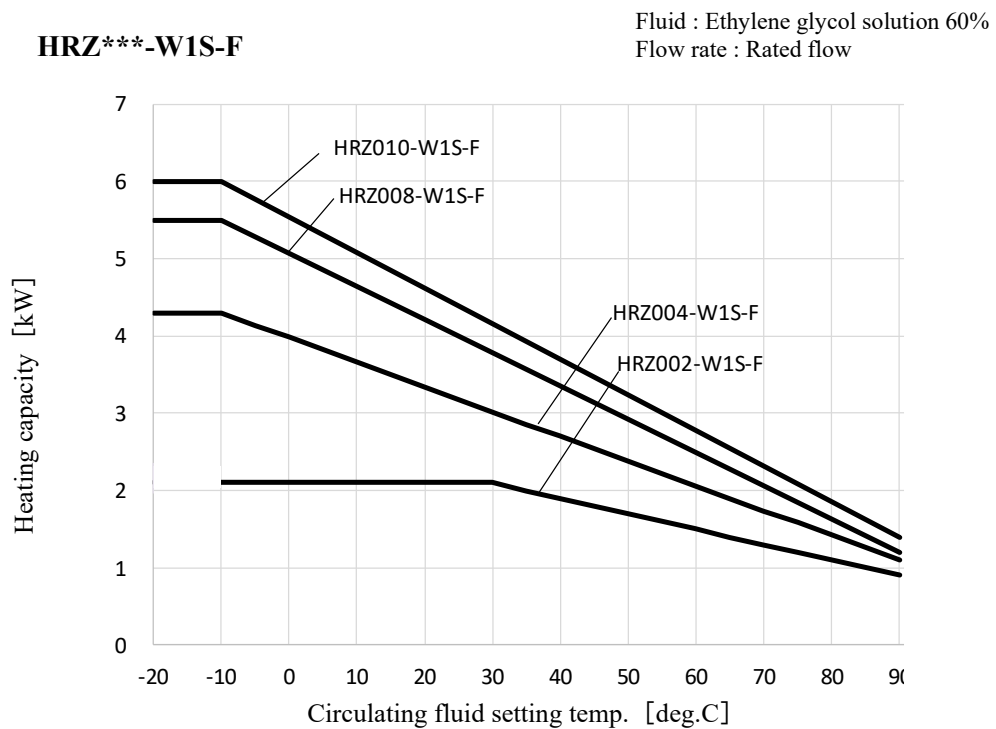

Fig. 8-7 Heating capacity (HRZ***-W1S-F)
* When pump inverter is operating at frequency of 60Hz (maximum).

HRZ***-W2S-F

Fluid : Water
Flow rate : Rated flow

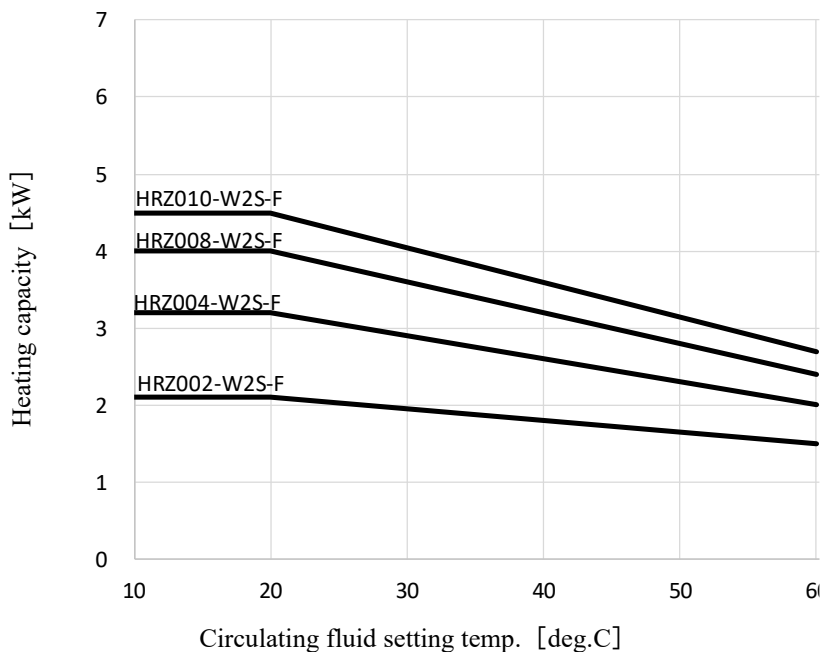

Fig. 8-8 Heating capacity (HRZ***-W2S-F)

* When pump inverter is operating at frequency of 60Hz (maximum).

HRZ008-L-F

Circulating Fluid: Fluorinated Fluid
Flow rate : Rated flow

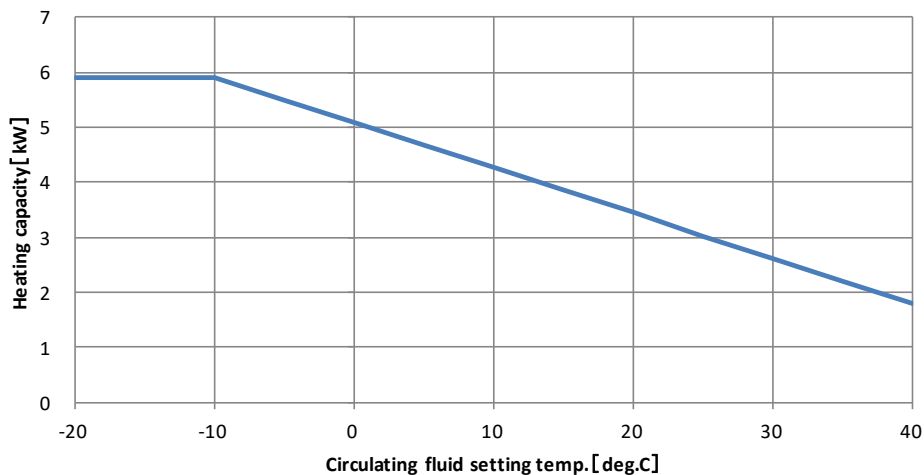

Fig. 8-9 Heating capacity (HRZ008-L-F)

* When pump inverter is operating at frequency of 60Hz (maximum).

HRZ008-L1-F

Fluid : Ethylene glycol solution 60%
Flow rate : Rated flow

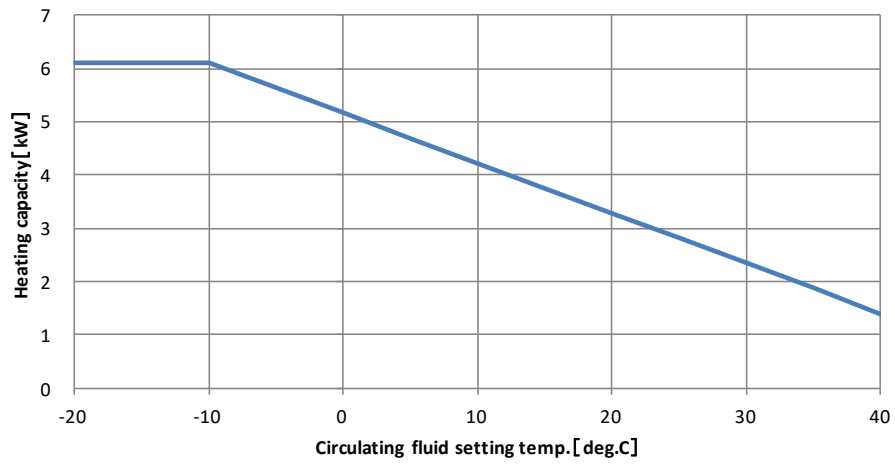

Fig. 8-10 Heating capacity (HRZ008-L1-F)
* When pump inverter is operating at frequency of 60Hz (maximum).

8.1.4 Pump Performance Curve

HRZ*-WS-F**

Circulating Fluid: Fluorinated Fluid
 Operating Temperature: 20 deg.C
 At maximum frequency operation by inverter

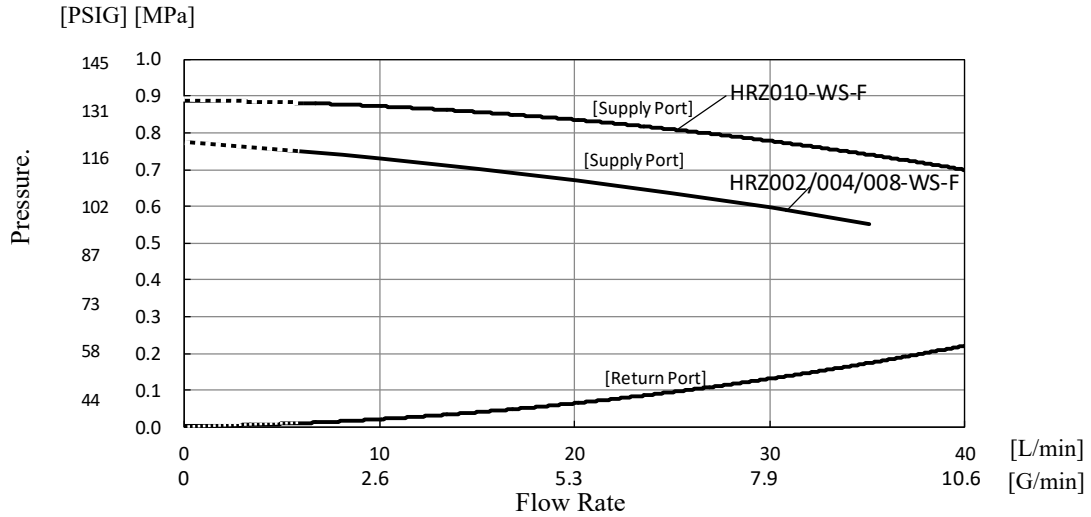

Figure 8-11 Pump Performance Curve (HRZ***-WS-F)
 When circulating fluid flow rate lowers 6L/min (1.6G/min), an alarm will occur and operation can't be performed.

HRZ*-W1S-F**

Circulating Fluid: Ethylene glycol solution 60%
 Operating Temperature: 20 deg.C
 At maximum frequency operation by inverter

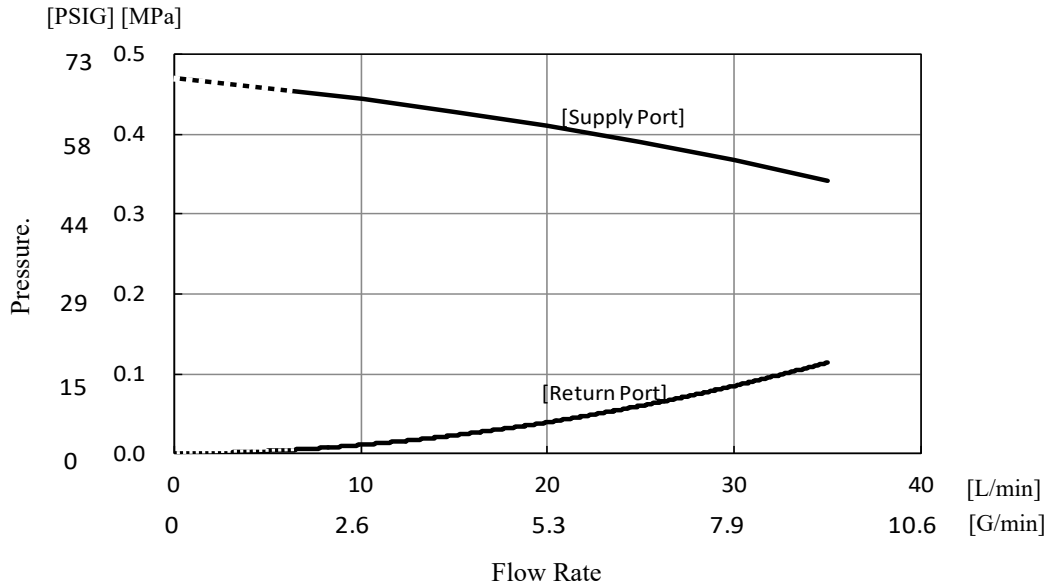

Figure 8-12 Pump Performance Curve (HRZ***-W1S-F)
 When circulating fluid flow rate lowers 6L/min (1.6G/min), an alarm will occur and operation can't be performed.

HRZ*-W2S-F**

Circulating Fluid: Water
 Operating Temperature: 20 deg.C
 At maximum frequency operation by inverter

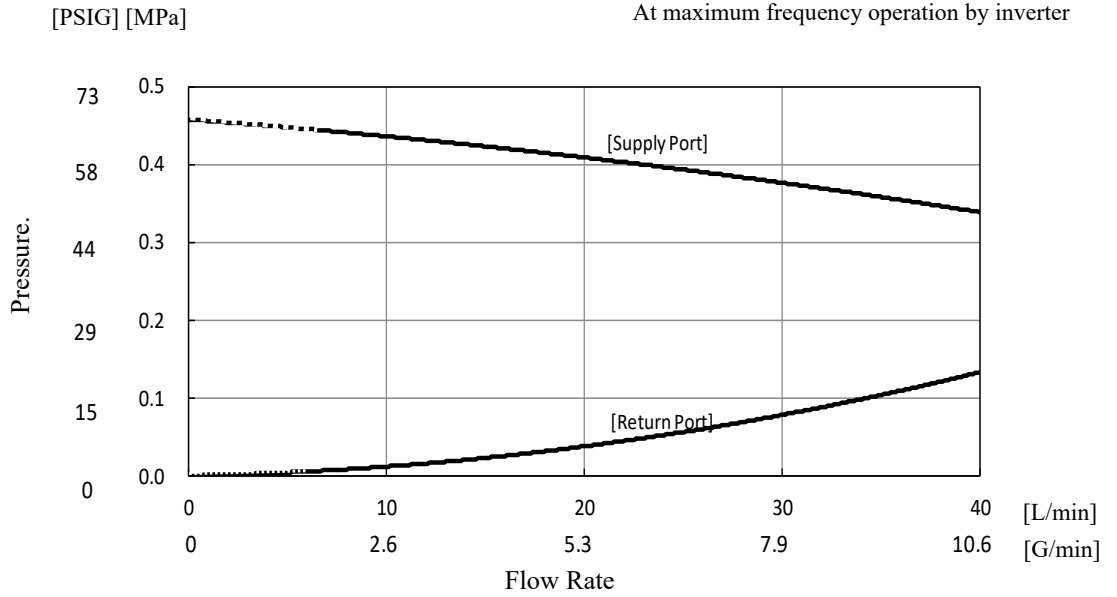

Figure 8-13 Pump Performance Curve (HRZ***-W2S-F)
 When circulating fluid flow rate lowers 6L/min (1.6G/min), an alarm will occur and operation can't be performed.

HRZ008-L-F

Circulating Fluid: Fluorinated Fluid
 Operating Temperature: 20 deg C
 At maximum frequency operation by inverter

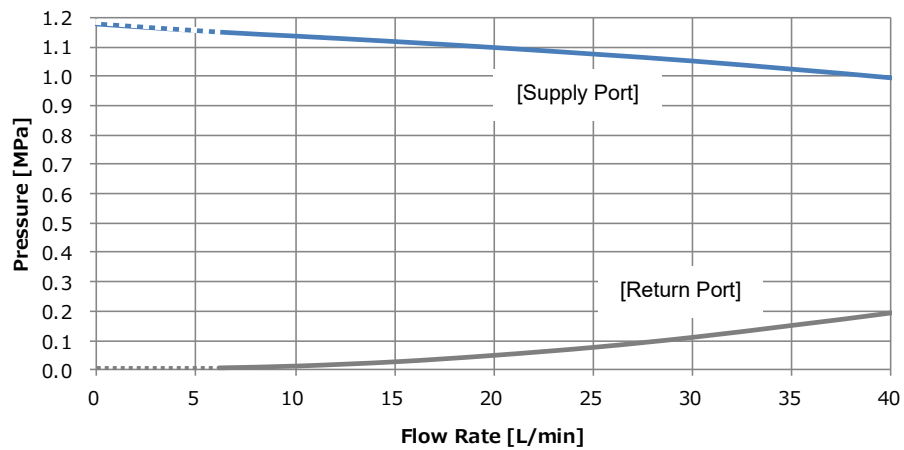

Fig. 8-14 Pump Performance Curve (HRZ008-L-F)
 When circulating fluid flow rate lowers 6L/min (1.6G/min), an alarm will occur and operation can't be performed.

HRZ008-L1-F

Circulating Fluid: Ethylene glycol solution 60%
Operating Temperature: 20 deg C
At maximum frequency operation by inverter

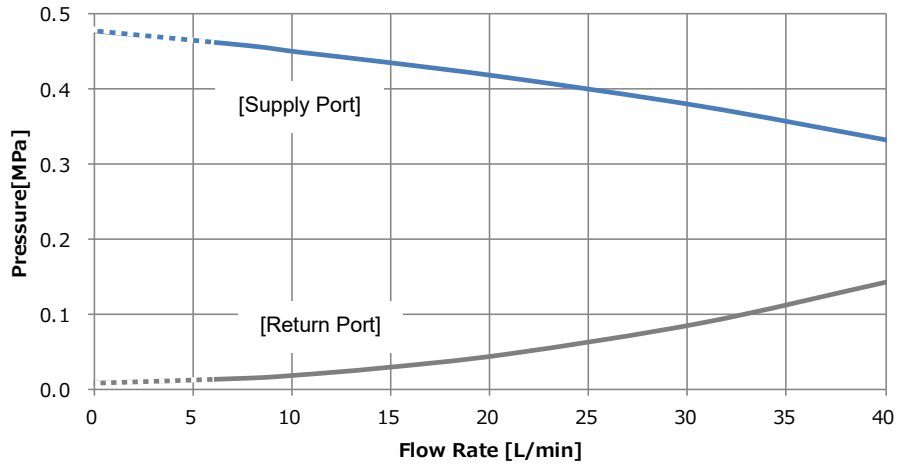

Fig. 8-15 Pump Performance Curve (HRZ008-L1-F)

When circulating fluid flow rate lowers 6L/min (1.6G/min), an alarm will occur and operation can't be performed.

8.1.5 Refrigerant with GWP reference

Table 8-6 Refrigerant with GWP reference

Refrigerant	Global Warming Potential (GWP)	
	Regulation (EU) No 517/2014 (Based on the IPCC AR4)	Revised Fluorocarbons Recovery and Destruction Law (Japanese law)
R134a	1,430	1,430
R404A	3,922	3,920
R407C	1,774	1,770
R410A	2,088	2,090
R448A	1,387	1,387

Note:

1. This product is hermetically sealed and contains fluorinated greenhouse gases.
2. See specification table for refrigerant used in the product.

8.1.6 Communication specification

This section provides the general outline of communications utilized in this system.

For detail specification, we provide a separate system manual “Communication Specification”, which is available through your local distributor.

■ Contact signal

Table 8-7 Contact Signal

Item		Specification																																																																																																		
Connector No.		P1																																																																																																		
Connector type (this system)		D-sub25P female connector(M2.6x0.45)																																																																																																		
Input signal	Insulation type	Photocoupler																																																																																																		
	Rated input voltage	DC24V																																																																																																		
	Used voltage range	DC 21.6V to 26.4V																																																																																																		
	Rated input current	5mA TYP																																																																																																		
	Input impedance	4.7kΩ																																																																																																		
Contact output signal (Other than Pin No. 5-18)	Rated load voltage	Max. AC48V / Max. DC30V																																																																																																		
	Max. load current	Max. AC/DC 800mA (Pin No. 15 is common to output signals. Total used load current should be at or below 800mA)																																																																																																		
Contact output signal (Pin No. 5-18)	Rated load voltage	Max. AC48V / Max. DC30V																																																																																																		
	Max. load current	AC/DC 800mA (resistance load)																																																																																																		
Contact output signal (EMO signal)	Rated load voltage	Max. AC48V / Max. DC30V																																																																																																		
	Max. load current	AC/DC 800mA (resistance load, inductive load)																																																																																																		
Analog input signal ^{*2}	Input voltage range	-10 to +10V																																																																																																		
	Input impedance	1MΩ																																																																																																		
	Input accuracy	±0.2% F.S. or less																																																																																																		
Analog output signal ^{*2}	Output voltage range	-10 to +10V																																																																																																		
	Max. output current	10mA																																																																																																		
	Output accuracy	±0.2% F.S. or less																																																																																																		
Circuit block diagram																																																																																																				
	<table border="1"> <thead> <tr> <th rowspan="2">Pin No</th> <th rowspan="2">I/O</th> <th colspan="2">ITEM</th> </tr> <tr> <th>Standard specification</th> <th>CUSTOM DIO</th> </tr> </thead> <tbody> <tr> <td>1</td> <td>Output</td> <td>DC+24V output</td> <td>DC+24V output</td> </tr> <tr> <td>2</td> <td>Input</td> <td>Input signal COM</td> <td>Input signal COM</td> </tr> <tr> <td>14</td> <td>Output</td> <td>24COM</td> <td>24COM</td> </tr> <tr> <td>3</td> <td>Input</td> <td>Run/Stop signal</td> <td>Run/Stop signal 1</td> </tr> <tr> <td>16</td> <td>Input</td> <td>-</td> <td>Run/Stop signal 2</td> </tr> <tr> <td>4</td> <td>Input</td> <td>AUTO PURGE signal^{*1}</td> <td>DIO REMOTE signal 1 AUTO PURGE signal^{*1}</td> </tr> <tr> <td>17</td> <td>Input</td> <td>-</td> <td>DIO REMOTE signal 2</td> </tr> <tr> <td>6</td> <td>Output</td> <td>Run status signal</td> <td>OUT1</td> </tr> <tr> <td>19</td> <td>Output</td> <td>Warning signal</td> <td>OUT2</td> </tr> <tr> <td>7</td> <td>Output</td> <td>Fault signal</td> <td>OUT3</td> </tr> <tr> <td>20</td> <td>Output</td> <td>Remote signal</td> <td>OUT4</td> </tr> <tr> <td>8</td> <td>Output</td> <td>TEMP READY signal AUTO PURGE status signal</td> <td>OUT5</td> </tr> <tr> <td>15</td> <td>Input</td> <td>Output signal COM</td> <td>Output signal COM</td> </tr> <tr> <td>5</td> <td>Output</td> <td></td> <td></td> </tr> <tr> <td>18</td> <td>Output</td> <td>Alarm signal</td> <td>OUT6</td> </tr> <tr> <td>11</td> <td>Output</td> <td>Temp.PV Analog Output^{*2}</td> <td>Temp.PV Analog Output^{*2}</td> </tr> <tr> <td>23</td> <td>Output</td> <td>[-100 to 100deg C:-10 to 10V]</td> <td>[-100 to 100deg C:-10 to 10V]</td> </tr> <tr> <td>10</td> <td>Output</td> <td>DI PV Analog Output^{*3}</td> <td>DI PV Analog Output^{*3}</td> </tr> <tr> <td>22</td> <td>Output</td> <td>[0 to 20 MΩ:0 to 10V]</td> <td>[0 to 20 MΩ:0 to 10V]</td> </tr> <tr> <td>12</td> <td>Input</td> <td>Temp.SP Analog Input^{*3}</td> <td>Temp.SP Analog Input^{*3}</td> </tr> <tr> <td>24</td> <td>Input</td> <td>[-100 to 100 deg C:-10 to 10V]</td> <td>[-100 to 100 deg C:-10 to 10V]</td> </tr> <tr> <td>13</td> <td>Output</td> <td>EMO signal</td> <td>EMO signal</td> </tr> <tr> <td>25</td> <td>Output</td> <td></td> <td></td> </tr> </tbody> </table>		Pin No	I/O	ITEM		Standard specification	CUSTOM DIO	1	Output	DC+24V output	DC+24V output	2	Input	Input signal COM	Input signal COM	14	Output	24COM	24COM	3	Input	Run/Stop signal	Run/Stop signal 1	16	Input	-	Run/Stop signal 2	4	Input	AUTO PURGE signal ^{*1}	DIO REMOTE signal 1 AUTO PURGE signal ^{*1}	17	Input	-	DIO REMOTE signal 2	6	Output	Run status signal	OUT1	19	Output	Warning signal	OUT2	7	Output	Fault signal	OUT3	20	Output	Remote signal	OUT4	8	Output	TEMP READY signal AUTO PURGE status signal	OUT5	15	Input	Output signal COM	Output signal COM	5	Output			18	Output	Alarm signal	OUT6	11	Output	Temp.PV Analog Output ^{*2}	Temp.PV Analog Output ^{*2}	23	Output	[-100 to 100deg C:-10 to 10V]	[-100 to 100deg C:-10 to 10V]	10	Output	DI PV Analog Output ^{*3}	DI PV Analog Output ^{*3}	22	Output	[0 to 20 MΩ:0 to 10V]	[0 to 20 MΩ:0 to 10V]	12	Input	Temp.SP Analog Input ^{*3}	Temp.SP Analog Input ^{*3}	24	Input	[-100 to 100 deg C:-10 to 10V]	[-100 to 100 deg C:-10 to 10V]	13	Output	EMO signal	EMO signal	25	Output		
	Pin No	I/O			ITEM																																																																																															
			Standard specification	CUSTOM DIO																																																																																																
	1	Output	DC+24V output	DC+24V output																																																																																																
	2	Input	Input signal COM	Input signal COM																																																																																																
	14	Output	24COM	24COM																																																																																																
	3	Input	Run/Stop signal	Run/Stop signal 1																																																																																																
	16	Input	-	Run/Stop signal 2																																																																																																
	4	Input	AUTO PURGE signal ^{*1}	DIO REMOTE signal 1 AUTO PURGE signal ^{*1}																																																																																																
	17	Input	-	DIO REMOTE signal 2																																																																																																
	6	Output	Run status signal	OUT1																																																																																																
	19	Output	Warning signal	OUT2																																																																																																
	7	Output	Fault signal	OUT3																																																																																																
	20	Output	Remote signal	OUT4																																																																																																
	8	Output	TEMP READY signal AUTO PURGE status signal	OUT5																																																																																																
	15	Input	Output signal COM	Output signal COM																																																																																																
	5	Output																																																																																																		
	18	Output	Alarm signal	OUT6																																																																																																
	11	Output	Temp.PV Analog Output ^{*2}	Temp.PV Analog Output ^{*2}																																																																																																
	23	Output	[-100 to 100deg C:-10 to 10V]	[-100 to 100deg C:-10 to 10V]																																																																																																
	10	Output	DI PV Analog Output ^{*3}	DI PV Analog Output ^{*3}																																																																																																
	22	Output	[0 to 20 MΩ:0 to 10V]	[0 to 20 MΩ:0 to 10V]																																																																																																
	12	Input	Temp.SP Analog Input ^{*3}	Temp.SP Analog Input ^{*3}																																																																																																
	24	Input	[-100 to 100 deg C:-10 to 10V]	[-100 to 100 deg C:-10 to 10V]																																																																																																
13	Output	EMO signal	EMO signal																																																																																																	
25	Output																																																																																																			
<p>*1: The recovery signal can be input only when the circulating fluid automatic collection function (optional) is used, and it does not serve as the DIO REMOTE signal.</p> <p>*2 :Valid if Analog Communication (optional) is provided.</p> <p>*3 :Valid if DI Control Kit (optional) is provided.</p>																																																																																																				

■ **Serial RS-485**

Table 8-8 Serial RS-485

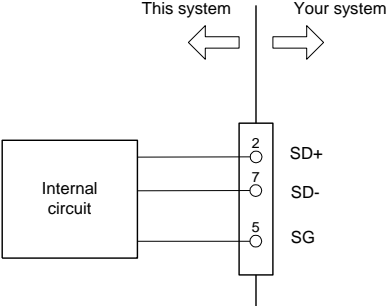
Item	Specification
Connector No.	P2
Connector type (this system)	D-sub9P female connector
Standard	EIA RS485
Protocol	Modicon Modbus
Circuit block diagram	 <p>The diagram shows an 'Internal circuit' box connected to a vertical P2 connector. The connector has three pins labeled 2, 7, and 5. Pin 2 is labeled 'SD+', pin 7 is labeled 'SD-', and pin 5 is labeled 'SG'. Above the connector, a vertical line is labeled 'This system' and 'Your system' with arrows pointing left and right, indicating bidirectional communication.</p>

8.1.7 Alarm signal selection

User can designate one alarm signal for contact signal. See section 5.3.22 Initial Setting screen 7 “page 5-25” for signal selecting.

The following table presents the setting-alarm relationship. The alarm signal is turned OFF if the designated alarm detected. (Alarm signal is ON if no alarm is detected.)

Table 8-9 Alarm signal selection

Setting	Alarm	Alarm
N/A	Alarm signal remains ON (closed) under normal circumstances.	-
ALARM01	Water Leak Detect FLT	01
ALARM03	RFGT High Press FLT	03
ALARM04	CPRSR Overheat FLT	04
ALARM05	Reservoir Low Level FLT	05
ALARM06	Reservoir Low Level WRN	06
ALARM07	Reservoir High Level WRN	07
ALARM08	Temp. Fuse Cutout FLT	08
ALARM09	Reservoir High Temp. FLT	09
ALARM10	Return High Temp. WRN	10
ALARM11	Reservoir High Temp. WRN	11
ALARM12	Return Low Flow FLT	12
ALARM13	Return Low Flow WRN	13
ALARM19	FAN Motor Stop WRN	19
ALARM20	Internal Pump Time Out WRN	20
ALARM21	Controller Error FLT	21
ALARM22	Memory Data Error FLT	22
ALARM23	Communication Error	23
ALARM24*1	DI Low Level WRN	24
ALARM25	Pump Inverter Error FLT	25
ALARM28*2	CPRSR Inverter Error FLT	28
ALARM29	RFGT Low Press FLT	29
ALARM32	Reservoir Low Temp. WRN	32

● Example

With parameter “OUT” on the Initial Setting screen set to “Alarm1”, alarm “Water Leak Detect FLT” is detected, the alarm contact signal is switched to OFF (open).

*1 : Alarm 24 is alarm assigned to accessories (optional).

2 : Alarm 28 is not assigned for HRZ008-L-F, the alarm signal always remains ON (closed).

8.2 Outer Dimensions

8.2.1 Part 1

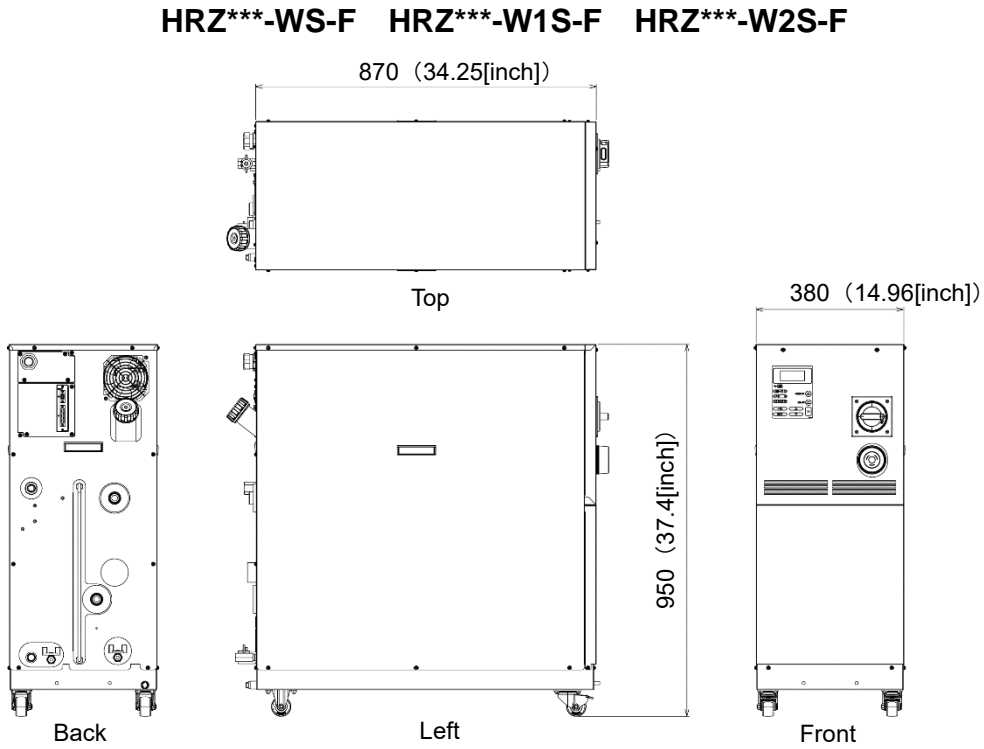

Figure 8-16 Outer Dimensions

8.2.2 Part 2

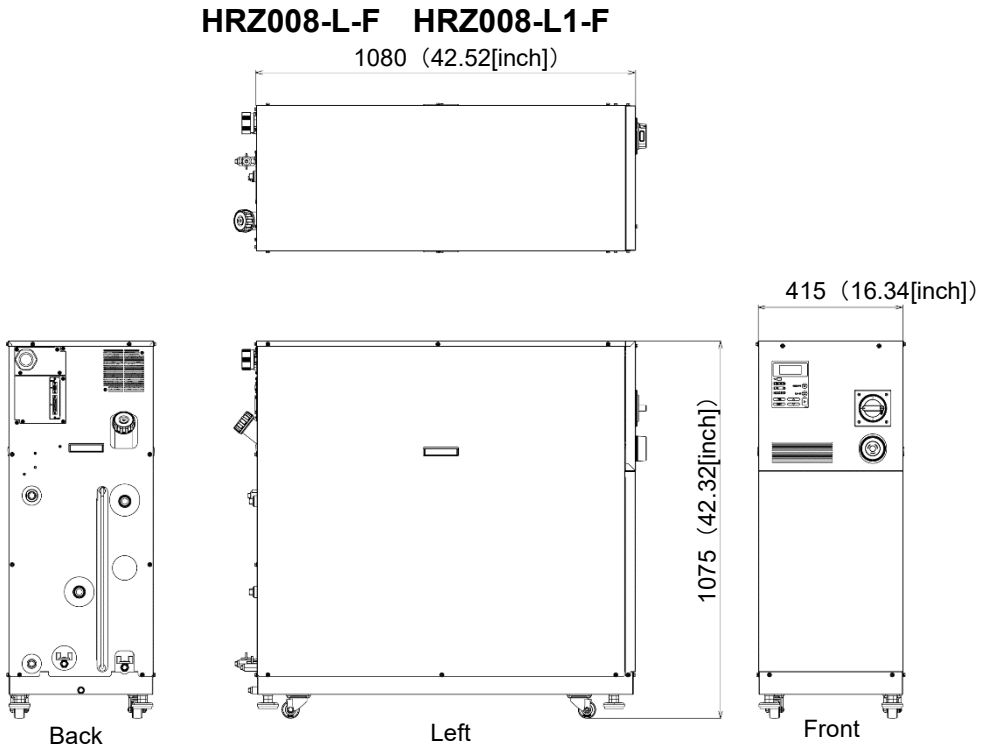

Figure 8-17 Outer Dimensions

8.3 Flow Chart

8.3.1 Part 1

HRZ***-WS-F HRZ***-W1S-F HRZ***-W2S-F

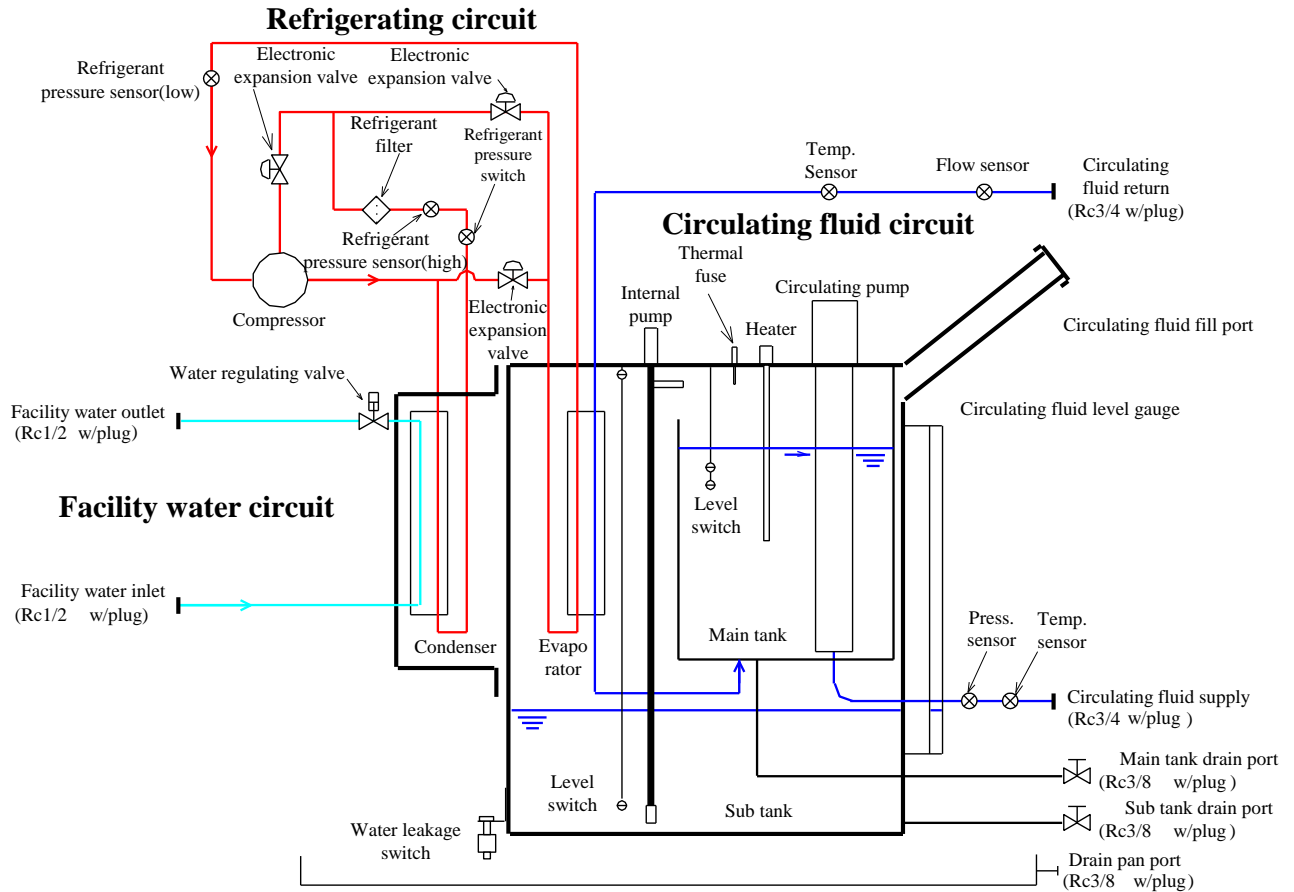

Figure 8-18 Flow Chart

8.3.2 Part 2

HRZ008-L-F HRZ008-L1-F

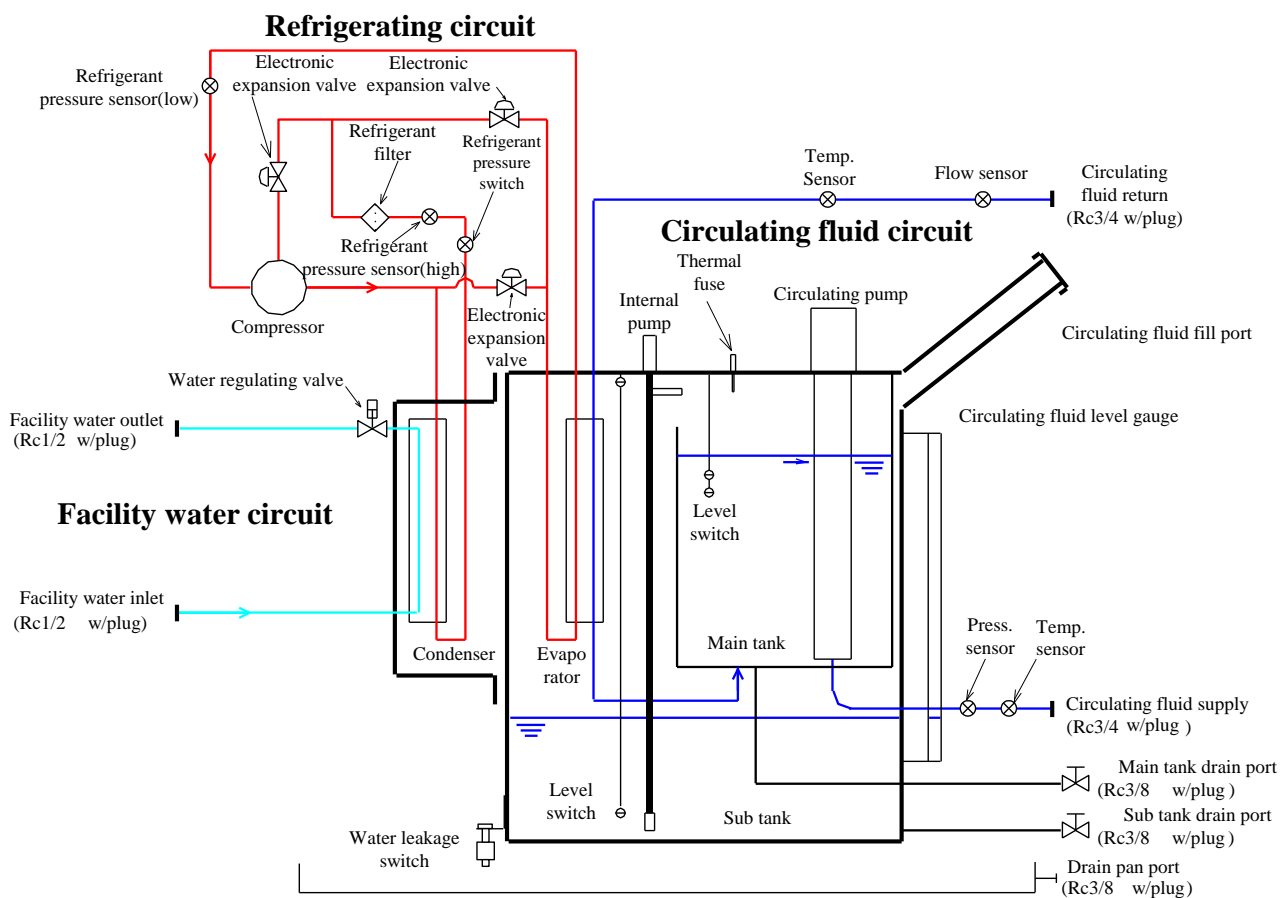

Figure 8-19 Flow Chart

8.4 Offset Function

Potential deviations in temperature between this system and your system may be concerned depending on the installation environment. The offset function falling into three types (MODE1 to 3) is assigned to calibrate deviations in temperature. See the following descriptions for the offset function. See section 5.3.16“Initial Setting screen 1”page5-19” for setting.

TEMP PV value, which is displayed on the Status screen, is output as circulating fluid temperature data in terms of communication.

● When MODE1 is selected

This mode is used to exercise temperature control to allow the discharge temperature of the circulating fluid to be “TEMP SP value + OFFSET value”. TEMP PV value denotes the discharge temperature of the circulating fluid.

E.g.: TEMP SP value: +20 deg C, OFFSET value: +2 deg C
→ Circulating fluid discharge temp.: +22 deg C, TEMP PV: +22 deg C

● When MODE2 is selected

This mode is used to exercise temperature control to allow the discharge temperature of the circulating fluid to be “TEMP SP value”. TEMP PV value denotes “Circulating fluid discharge temp. value + OFFSET value”.

E.g.: TEMP SP value: +20 deg C, OFFSET value: +2 deg C
→ Circulating fluid discharge temp.: +20 deg C, TEMP PV: +22 deg C

● When MODE3 is selected

This mode is used to exercise temperature control to allow the discharge temperature of the circulating fluid to be “TEMP SP value + OFFSET value”. TEMP PV value denotes “Circulating fluid discharge temp. value - OFFSET value”.

E.g.: TEMP SP value: +20 deg C, OFFSET value: +2 deg C
→ Circulating fluid discharge temp.: +20 deg C, TEMP PV: +20 deg C

● When OFF is selected

If no mode is selected, temperature control is conducted to allow the discharge temperature of the circulating fluid to be “TEMP SP value”.

8.4.1 Example of offset function

When the discharge temperature of the circulating fluid is at 30deg C, heat is dissipated by 1deg C to allow the circulating fluid in your system to be 29deg C. Under the above condition, the following process is to be performed with the utilization of MODEs 1 to 3.

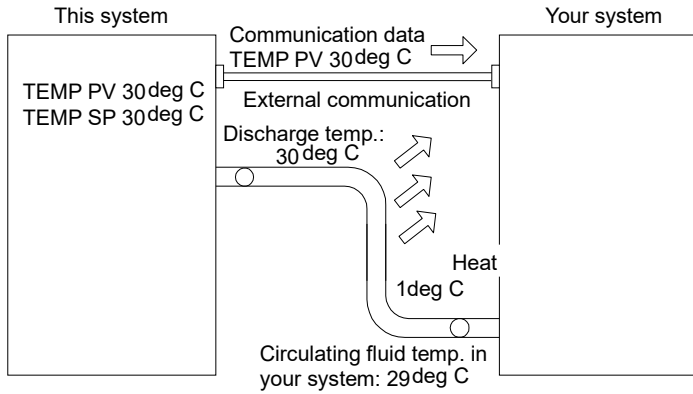

Figure 8-20 Example of Offset Function

■ When MODE1 is selected

This mode enables this system to exercise temperature control to obtain 31deg C (TEMP SP value +OFFSET value), with OFFSET value set at 1deg C. Once the discharge temperature of the circulating fluid becomes 31deg C, 1deg C-thermal dissipation is assured to allow the circulating fluid in your system to be 30deg C. TEMP SP value is obtained for your system.

Note that “31deg C” is recorded in TEMP PV and communication data.

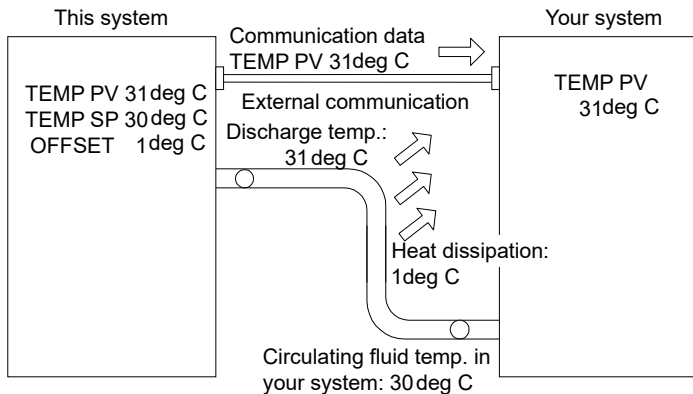

Figure 8-21 When MODE1 is selected

■ **When MODE2 is selected**

With OFFSET value set at -1deg C, TEMP PV and communication data express “29deg C” (circulating fluid discharge temp. value + OFFSET value) that agrees with the temperature of the circulating fluid in your system.

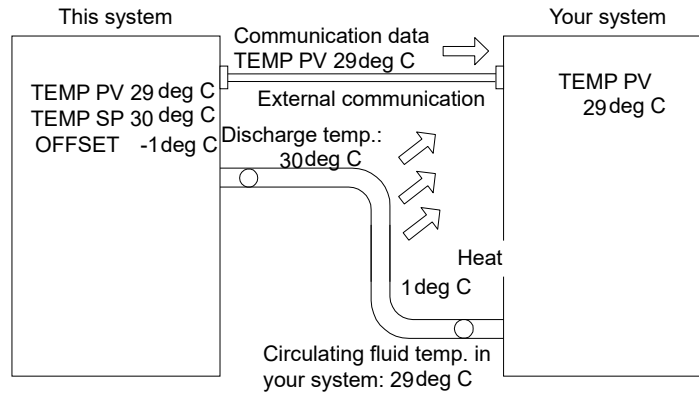

Figure 8-22 When MODE2 is selected

■ **When MODE3 is selected**

This mode enables this system to exercise temperature control to obtain 31deg C (TEMP SP value +OFFSET value), with OFFSET value set at 1deg C. Once the discharge temperature of the circulating fluid becomes 31deg C, 1deg C-thermal dissipation is assured to allow the circulating fluid in your system to be 30deg C. TEMP SP value is obtained for your system. TEMP PV and communication data also express “30deg C” (circulating fluid discharge temp. value - OFFSET value) that agrees with the temperature of the circulating fluid in your system.

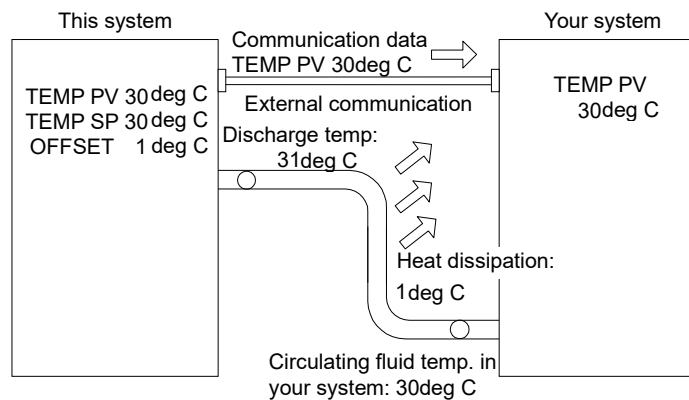

Figure 8-23 When MODE3 is selected

8.5 BAND/READY function

Sets BAND to TEMP SP value, and notifies TEMP PV value reaches within BAND range by the operation display panel or the communication.

See section “Chapter 5 System Operation 5.3.21 Initial Setting screen 6” on page 5-24, for the procedure of the setting.

● When the setting is ON

Allows the setting of the BAND and REDY TIME. Allows the setting of the communication output.

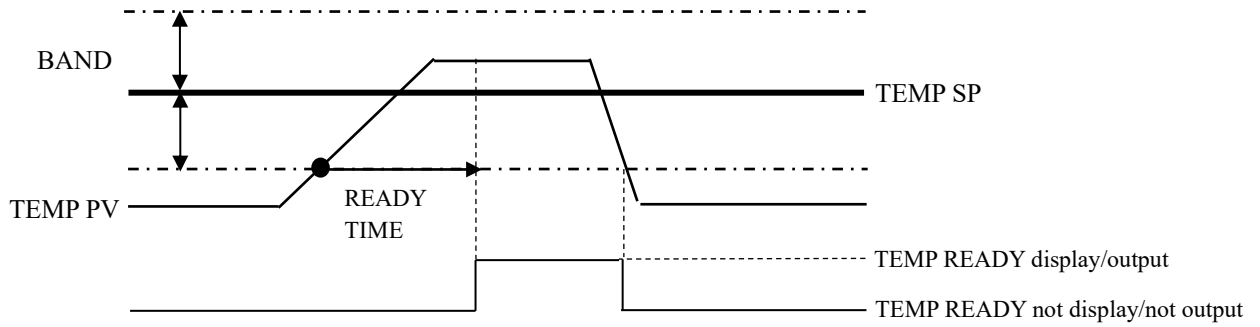

Figure 8-24 BAND/READY function

● Examples of Setting

TEMP SP : 20deg C

BAND : 2deg C

READY TIME : 60sec.

”TEMP READY” is displayed on the operation display panel 60-sec. after TEMP PV value becomes 18 deg C to start output by communication. Necessary condition is that TEMP PV value after 60-sec. is 20+/-2.0 deg C or less. See “5.3.4 Status screen 3” on page 5-7 for the details of display position.

● When the setting is OFF

BAND/READY function becomes invalid.

8.6 Anchor Bolt Mounting Position

8.6.1 Part 1

HRZ***-WS-F HRZ***-W1S-F HRZ***-W2S-F

Lock the brakes on casters (2 pcs. on the front), and attach the anti-seismic bracket (optional: HRZ-TK002) to secure this system.

⚠ CAUTION



- Anti-seismic bracket is an optional accessory, which is required for the installation of this system (HRZ-TK002).
- It is your responsibility to prepare anchor bolts suitable for your floor material. M12-anchor bolts (4 pcs.) are required.

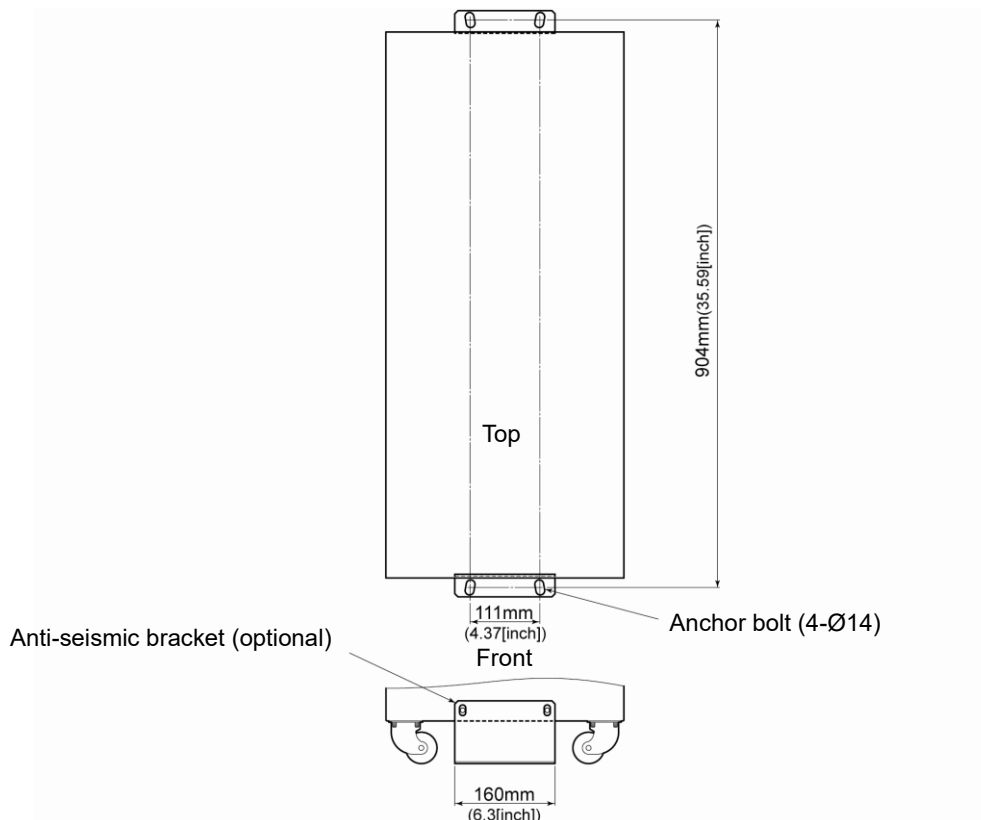



Figure 8-25 Anchor Bolt Mounting Position

8.6.2 Part 2

HRZ008-L-F HRZ008-L1-F

Adjust and secure the adjuster foot of this system to secure the anti-seismic bracket.

⚠ CAUTION



- Anti-seismic bracket is an accessory, which is required for the installation of this system.
- It is your responsibility to prepare anchor bolts suitable for your floor material. M8-anchor bolts (8 pcs.) are required.

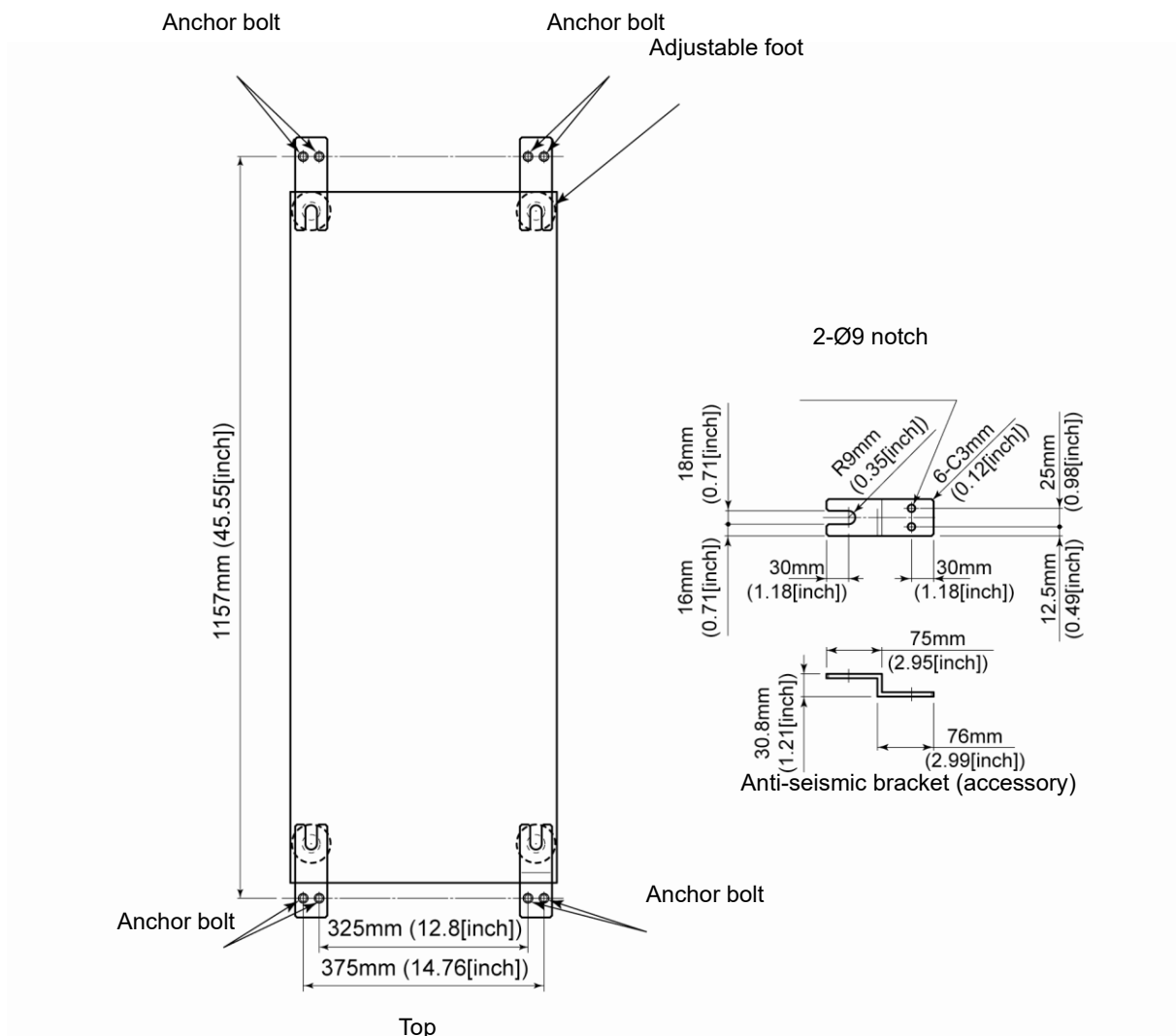

Figure 8-26 Anchor Bolt Mounting Position

8.7 Compliance

This system conforms to the following standards.

Table 8-10 Compliance

CE Marking	EMC Directive	2014/30/EU
	Machinery Directive	2006/42/EC
	RoHS Directive	2011/65/EU
SEMI	S2,S8,F47	
UL	E229305 / UL1995	



Model:
Serial No.

To confirm daily inspection item on the Thermo Chiller, See "Table 7-2 Daily Inspection" in "7.2.1 Daily inspection" of "Chapter 7."

Your name	Date	Installation		Leakage		Fluid Level	Operation display panel		Circulating fluid temp.	Refrigerant press.	Circulating fluid outlet press.	Circulating fluid flowrate	Operating condition	Facility water		Circulating fluid supply port cap	Judgment
		Temp. °C	Humidity %	Circulating fluid	Cooling water		Display	Function						Temp. °C	Flowrate L/min		
After installation (initial value)																	

Chapter 9 Product Warranty

1. Warranty

If a failure is observed in our Thermo Chiller, repair shall be provided in accordance with the warranty period and preconditions defined below at SMC's option.

Repair involves the inspection and/or replacement and/or modification of a defective part.
Removed parts shall become the possession of SMC.

2. Warranty period

The warranty period of the product is 1 year in service or 1.5 years after the product is delivered, whichever is first.

3. Warranty exemption

SMC's liability under this warranty shall not be available for the following troubles and damages.

- (1) Troubles or damage caused by the neglect of our designated inspection (daily inspection, periodic inspection).
- (2) Troubles or damages caused by mishandling such as using improper operating procedure and using with our specifications violated.
- (3) Troubles or damages caused by unauthorized modification.
- (4) Troubles or damages caused by the use of a not-designated circulating fluid and facility water.
- (5) Troubles or damages caused by wearing out such as fading on the coated or plated surface.
- (6) Sensory phenomena that are considered no effect on the functions (such as noise, vibration).
- (7) Troubles or damages caused by natural disaster such as earthquake, typhoon, water, inevitable events and fire.
- (8) Troubles or damages occurred under the installation conditions defined in the Operation Manual.
- (9) Troubles or damages that are not compliant with the "5. Warranty preconditions".

4. Escape clause

- (1) Expenses of daily inspection and periodic inspection.
- (2) Expenses of repair consigned with neither SMC nor our authorized service station.
- (3) Expenses of transport, installation, and removal of this system.
- (4) Expenses of removal of non-genuine parts and replenishment of non-genuine fluids.
- (5) Unavailability and loss due to this system being disabled.
(such as telephone bill, leave compensation, commercial loss)
- (6) Expenses and compensation for terms other than provided in "1. Warranty".

5. Warranty precondition

Proper use and inspection of this system is required to assure safe use of this system. System warranty shall satisfy the following preconditions. Please take note that warranted repair shall not be available if these preconditions are disregarded.

- (1) System operation shall be conducted by following operating procedure defined in the Operation Manual.
- (2) Daily and periodic inspections designated in the Operation Manual shall be made as scheduled.
- (3) Inspection record shall be entered in the Daily Inspection Sheet provided in the Operation Manual.

6. Request for warranted repair

As to warranted repair, please contact the supplier you purchased this system from for service.
Warranted repair shall be on request basis.

Unrequited repair shall be provided in accordance with the warranty period, preconditions and terms defined above. Therefore, the repair service shall be available on a chargeable basis if a failure is detected after the warranty period.

Revision
Rev.F : May.2023

SMC Corporation

4-14-1, Sotokanda, Chiyoda-ku, Tokyo 101-0021 JAPAN

Tel: + 81 3 5207 8249 Fax: +81 3 5298 5362

URL <https://www.smcworld.com>

Note: Specifications are subject to change without prior notice and any obligation on the part of the manufacturer.
© 2023 SMC Corporation All Rights Reserved