



# Operation Manual

## Installation • Operation

Original Instructions  
Thermo-chiller

**HRLE Series**    **CE**    **UK**  
**CA**

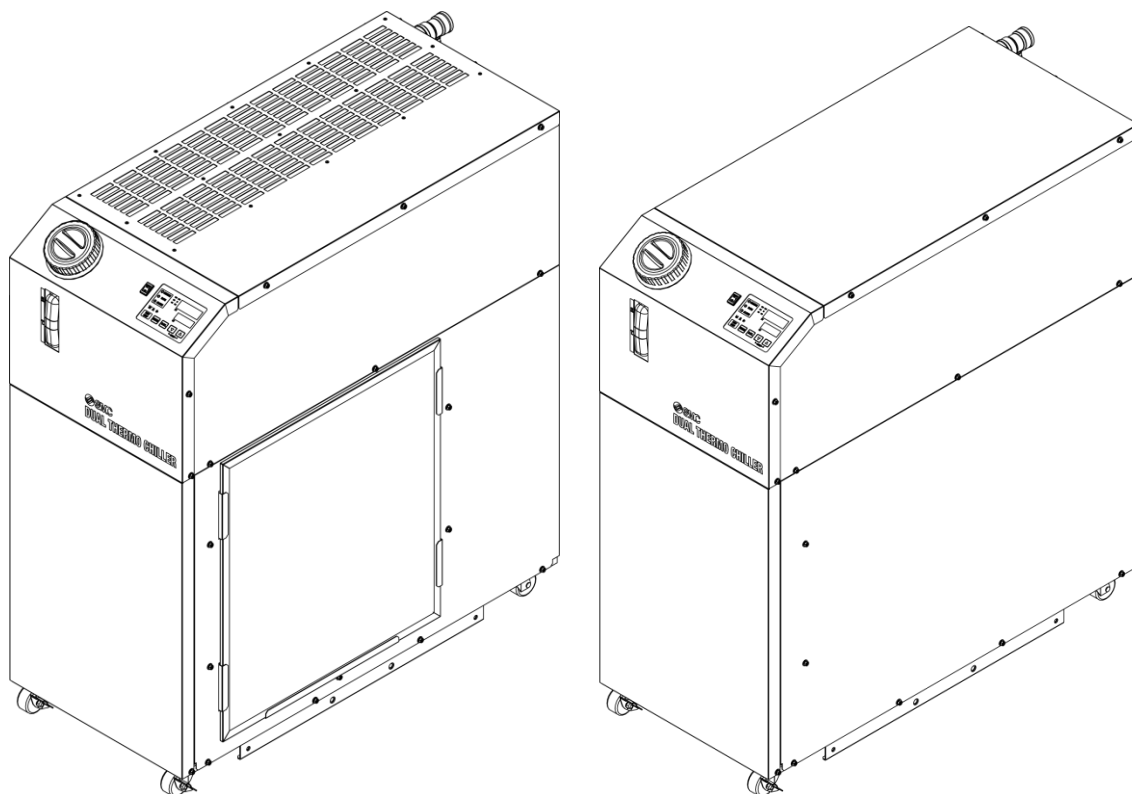

# SMC Corporation

Keep this manual available whenever necessary

## To Users,

Thank you for purchasing SMC's Thermo-chiller (hereinafter referred to as the "product").

For safety and long life of the product, be sure to read this Operation Manual (hereinafter referred to as the "manual") and clearly understand the contents.

- Be sure to follow all instructions marked with "Warning" or "Caution" in this manual.
- This manual is intended to explain the installation and operation of the product. Only people who understand the basic operation of the product through this manual or who install and operate industrial machinery and have basic knowledge and ability to handle such equipment are allowed to work on the product.
- This manual and other documents included with the product do not constitute a contract, and will not affect any existing agreements or commitments.
- It is strictly prohibited to copy this manual entirely or partially for use by a third party without prior permission from SMC.

**Note: The contents of this operation manual are subject to change without prior notice.**

# Contents

<b>Chapter 1</b>	<b>Safety Instructions .....</b>	<b>1-1</b>
1.1	Before Using This System.....	1-1
1.2	Before Reading this Manual .....	1-1
1.3	Hazards.....	1-2
1.3.1	Level of hazard .....	1-2
1.3.2	Definition of "Serious injury" and "Minor injury" .....	1-2
1.3.3	Types of hazard labels .....	1-3
1.3.4	Locations of Hazard Labels.....	1-4
1.4	Product Label.....	1-5
1.5	Safety Measures .....	1-6
1.5.1	Safety instructions for use .....	1-6
1.5.2	Personal protective equipment.....	1-8
1.6	Emergency Measures .....	1-9
1.7	Waste Disposal.....	1-9
1.7.1	Disposal of refrigerant and compressor oil.....	1-9
1.7.2	Disposal of the product.....	1-9
1.8	Safety Data Sheet (SDS) .....	1-10
<b>Chapter 2</b>	<b>Names and Functions of Parts .....</b>	<b>2-1</b>
2.1	Name of Each Part.....	2-1
2.1.1	HRLE050-A-20-*(In case of Air-cooled refrigeration) .....	2-1
2.1.2	HRLE050-W-20-*(In case of Water-cooled refrigeration) .....	2-2
2.1.3	HRLE090-A-20/40-*(In case of Air-cooled refrigeration) .....	2-3
2.1.4	HRLE090-W-20/40-*(In case of Water-cooled refrigeration) .....	2-4
2.2	Function of Each Part.....	2-5
2.3	Operation Panel .....	2-5
<b>Chapter 3</b>	<b>Transport and Set Up .....</b>	<b>3-1</b>
3.1	Transport .....	3-1
3.1.1	Transportation using a forklift and slinging.....	3-2
3.1.2	Transportation using casters .....	3-3
3.2	Installation .....	3-4
3.2.1	Environment .....	3-4
3.2.2	Location .....	3-5
3.2.3	Installation and maintenance space.....	3-7
3.3	Installation Procedure .....	3-8
3.3.1	Installation procedure .....	3-8
3.3.2	Electrical wiring .....	3-11
3.3.3	Preparation and wiring of power supply cable .....	3-12
3.3.4	Preparation and wiring of communication cable .....	3-18
3.4	Piping.....	3-25

3.5	Circulating Fluid Supply.....	3-27
<b>Chapter 4</b>	<b>Starting the Product.....</b>	<b>4-1</b>
4.1	Before Starting .....	4-1
4.2	Preparation for Start.....	4-2
4.2.1	Power supply .....	4-2
4.2.2	Setting of circulating fluid temperature .....	4-2
4.3	Operation Start and Stop .....	4-3
4.3.1	Starting the Product .....	4-3
4.3.2	Stopping the product.....	4-4
4.4	Check Items during Startup .....	4-4
4.5	Adjustment of Circulating Fluid Flow Rate .....	4-5
<b>Chapter 5</b>	<b>Display and Setting of Various Functions .....</b>	<b>5-1</b>
5.1	List of Functions .....	5-1
5.2	Function.....	5-2
5.2.1	Key operations.....	5-2
5.2.2	List of display and setting .....	5-4
5.3	Main Menu.....	5-7
5.3.1	Main menu .....	5-7
5.3.2	Setting the circulating fluid discharge temperature .....	5-7
5.3.3	Setting the CH1 circulating fluid discharge pressure (When selecting Option P) .....	5-8
5.4	Alarm Menu .....	5-9
5.4.1	Alarm menu .....	5-9
5.4.2	Items shown on the alarm menu .....	5-9
5.5	Monitor Menu .....	5-10
5.5.1	Monitor menu .....	5-10
5.6	Setting Menu.....	5-11
5.6.1	Setting menu.....	5-11
5.6.2	Key-lock setting .....	5-12
5.6.3	Key click sound setting .....	5-12
5.6.4	Band width setting for the TEMP READY signal .....	5-12
5.6.5	Setting of time for TEMP READY signal for out of range .....	5-13
5.6.6	Anti-freezing function setting .....	5-13
5.6.7	Fan output upper limit.....	5-13
5.6.8	Electric conductivity function setting.....	5-14
5.6.9	Reset the setting.....	5-14
5.6.10	Reset of the accumulated operating time of the dust-proof filter.....	5-14
5.7	Alarm Setting Menu .....	5-15
5.7.1	Alarm setting menu.....	5-15
5.7.2	Alarm sound setting .....	5-15
5.7.3	Discharge pressure rise alarm (AL08) switching .....	5-16
5.7.4	Threshold for discharge pressure rise alarm (AL08) setting .....	5-16
5.7.5	Discharge pressure drop alarm (AL09) switching .....	5-16
5.7.6	Threshold for discharge pressure drop alarm (AL09) setting.....	5-16

<b>5.8</b>	<b>Communication Setting Menu</b> .....	<b>5-17</b>
5.8.1	Communication setting menu.....	5-17
5.8.2	Communication status display .....	5-18
5.8.3	Operation mode switching.....	5-19
5.8.4	Serial communication protocol switching .....	5-19
5.8.5	Serial communication termination resistance switching.....	5-19
5.8.6	Serial communication device address setting .....	5-19
5.8.7	Serial communication switching the communication speed.....	5-20
5.8.8	Serial communication alarm switching .....	5-20
5.8.9	Serial communication alarm detection time setting.....	5-20
5.8.10	Switching the signal type of the contact input .....	5-20
5.8.11	Switching the signal form of the contact input.....	5-21
5.8.12	Contact type switching of contact input.....	5-21
5.8.13	Alarm switching for contact input .....	5-21
5.8.14	Delay time setting for contact input .....	5-21
5.8.15	OFF detection time setting for contact input .....	5-22
5.8.16	Switching the signal type of contact output.....	5-22
5.8.17	Contact type switching of contact output.....	5-23
5.8.18	Selective alarm setting for contact output .....	5-23
<b>5.9</b>	<b>Electric conductivity Control Function</b> .....	<b>5-24</b>
5.9.1	Electric conductivity .....	5-25
5.9.2	Electric conductivity control method setting .....	5-25
5.9.3	Electric conductivity setting .....	5-25
5.9.4	Electric conductivity hysteresis setting.....	5-25
5.9.5	Threshold for Electric conductivity rise alarm (AL34) setting .....	5-26
5.9.6	Accumulated operating time of the DI filter .....	5-26
5.9.7	Reset of the accumulated operating time of the DI filter .....	5-26
<b>5.10</b>	<b>Anti-freezing Function</b> .....	<b>5-27</b>
<b>Chapter 6</b>	<b>Option</b> .....	<b>6-1</b>
<b>6.1</b>	<b>Option List</b> .....	<b>6-1</b>
<b>6.2</b>	<b>Option C [With inverter for compressor]</b> .....	<b>6-1</b>
<b>6.3</b>	<b>Option M [Deionized water (Pure water) piping]</b> .....	<b>6-1</b>
<b>6.4</b>	<b>Option P [With inverter for pump]</b> .....	<b>6-2</b>
<b>Chapter 7</b>	<b>Alarm Notification and Troubleshooting</b> .....	<b>7-1</b>
<b>7.1</b>	<b>Alarm Notification</b> .....	<b>7-1</b>
<b>7.2</b>	<b>Alarm Sound Stop</b> .....	<b>7-3</b>
<b>7.3</b>	<b>Troubleshooting</b> .....	<b>7-4</b>
7.3.1	Alarm details, causes, and troubleshooting .....	7-4
7.3.2	How to reset the refrigerant high pressure switch (When AL65 occurred) .....	7-6
<b>7.4</b>	<b>Other Errors</b> .....	<b>7-8</b>
<b>Chapter 8</b>	<b>Control, Inspection and Cleaning</b> .....	<b>8-1</b>
<b>8.1</b>	<b>Water Quality Management</b> .....	<b>8-1</b>
<b>8.2</b>	<b>Inspection and Cleaning</b> .....	<b>8-2</b>

**Contents**

---

- 8.2.1 Daily check ..... 8-2
- 8.2.2 Monthly check ..... 8-3
- 8.2.3 3-month inspections ..... 8-4
- 8.2.4 6-month inspections ..... 8-5
- 8.2.5 Inspection during winter season ..... 8-6
- 8.3 Consumables ..... 8-6**
- 8.4 Operation Stop for an Extended Period of Time ..... 8-7**
  - 8.4.1 Discharge of the circulating fluid ..... 8-7
  - 8.4.2 Drain of the facility water ..... 8-8
- Chapter 9 Documents ..... 9-1**
  - 9.1 Specifications ..... 9-1**
    - 9.1.1 HRLE050-A-20-\* ..... 9-1
    - 9.1.2 HRLE090-A-20-\* ..... 9-2
    - 9.1.3 HRLE050-W-20-\* ..... 9-3
    - 9.1.4 HRLE090-W-20-\* ..... 9-4
    - 9.1.5 HRLE090-A-40-\* ..... 9-5
    - 9.1.6 HRLE090-W-40-\* ..... 9-6
  - 9.2 Refrigerant and GWP Value ..... 9-7**
  - 9.3 Dimensions ..... 9-8**
    - 9.3.1 HRLE050-A-20-\* ..... 9-8
    - 9.3.2 HRLE050-W-20-\* ..... 9-9
    - 9.3.3 HRLE090-A-20/40-\* ..... 9-10
    - 9.3.4 HRLE090-W-20/40-\* ..... 9-11
  - 9.4 Flow Diagram ..... 9-12**
    - 9.4.1 HRLE050-A-20-\*,HRLE090-A-20/40-\* ..... 9-12
    - 9.4.2 HRLE050-W-20-\*,HRLE090-W-20/40-\* ..... 9-12
  - 9.5 Cooling Capacity ..... 9-13**
    - 9.5.1 HRLE050-A-20-\* ..... 9-13
    - 9.5.2 HRLE050-W-20-\* ..... 9-13
    - 9.5.3 HRLE090-A-20/40-\* ..... 9-14
    - 9.5.4 HRLE090-W-20/40-\* ..... 9-14
  - 9.6 Pump Capacity ..... 9-15**
  - 9.7 Heating capacity ..... 9-16**
  - 9.8 Required facility water flow ..... 9-18**
  - 9.9 Sample DoC ..... 9-19**
  - 9.10 Standards ..... 9-21**
  - 9.11 Daily check sheet ..... 9-22**
- Chapter 10 Limited warranty and Disclaimer/ Compliance Requirements ..... 10-1**

# Chapter 1 Safety Instructions



**Before using the product, be sure to read and understand all the important actions highlighted in this manual.**

## 1.1 Before Using This System

- This "Safety" chapter describes the safety-related items that users should be aware of upon handling this system.
- The product is a circulating fluid temperature controller. SMC does not take any responsibility for any problems that may arise from using the product for other purposes.
- This product is not designed for a clean room. It generates dust from the internal components such as pump and fan motor.
- This system, which is operated under high voltage, is outfitted with the parts that cause a rise or drop in temperature and rotating parts when it is in action. All personnel who work with or around this system are required to thoroughly read and understand the safety-related items in this manual prior to working with or around this system.

If a component needs to be replaced or repaired, contact a specialized vendor for parts and service.

- The relevant personnel must receive proper safety education prior to work training on this system. Otherwise, personnel may be exposed to hazards. Never conduct work training without giving proper consideration to safety.
- This manual is not intended to be used as a manual for comprehensive safety and hygiene education. Such a manual should be provided by a safety training manager.
- A safety manager is responsible for observing safety standards. Operators and maintainers, however, are to have individual responsibilities for complying with the safety standard in his/her daily work.
- Operators and maintainers must individually take account of safety and assure a proper working area and working environment.
- This appliance is not intended for use by persons (including children) with reduced physical, sensory or mental capabilities, or lack of experience and knowledge, unless they have been given supervision or instruction concerning use of the appliance by a person responsible for their safety.
- Save this manual at a designated place for reference when necessary.

## 1.2 Before Reading this Manual

This manual contains symbols to help identify important actions for when installing, operating, or maintaining the product.



**This symbol indicates actions that must be followed.**



**This symbol indicates prohibited actions.**

## 1.3 Hazards

### 1.3.1 Level of hazard

The instructions given in this manual aim to ensure that the product is operated in a safe and correct way. This will prevent injury to operators and damage to the product. These instructions are grouped into three categories, "Danger", "Warning" and "Caution", which indicate the level of hazard, damage, and also the degree of emergency. Content with these symbols are important instructions concerning safety. Note where these symbols are, read them, and fully comprehend the cautions and warnings before handling the product.

"DANGER", "WARNING" and "CAUTION" symbols are in order of severity (DANGER > WARNING > CAUTION). The meanings of these symbols are as follows.

#### **DANGER**

"DANGER": Hazard that **WILL** cause serious personal injury or death during operation.

#### **WARNING**

"WARNING": Hazard that **could** cause serious personal injury or death during operation.

#### **CAUTION**

"CAUTION": Hazard that **MAY** cause minor personal injury during operation.

#### **CAUTION**

"CAUTION without exclamation point": Hazard that **MAY** cause damage or failure of the product, facility, devices, etc.

#### **[Tips]**

Tips are provided when there is information personnel are required to be aware of for system operation and maintenance. If the task carries useful information, the relevant tips are given as well.

### 1.3.2 Definition of "Serious injury" and "Minor injury"

#### "Serious injury"

This term describes injuries such as burns, electric shock, fractures, and poisoning that result in after effects such as loss of eyesight, and that require long-term treatment or hospitalization.

#### "Minor injury"

This term describes injuries that do not need long-term treatment or hospitalization. (Anything else not included in "Serious injury".)



### 1.3.3 Types of hazard labels

The product has various potential hazards and they are marked with warning labels. Be sure to read this section before starting any work on the product.

#### ■ Warning related to electricity

<b>⚠ WARNING</b>	
	<p>This symbol stands for a possible risk of electric shock.</p> <p>The product is operated at high voltage and contains uncovered live terminals inside.</p> <ul style="list-style-type: none"><li>● DO NOT operate the product without cover panels fitted.</li><li>● DO NOT work inside this product unless you have been trained to do so.</li></ul>

#### ■ Warning related to high temperatures

<b>⚠ WARNING</b>	
	<p>This symbol stands for a possible risk of hot surface and burns.</p> <p>The product has surfaces that can reach high temperatures during operation. Even after the power is turned off, there can still be residual heat in the product.</p> <ul style="list-style-type: none"><li>● DO NOT operate the product without cover panels fitted.</li><li>● DO NOT start working inside the product until the temperature has decreased sufficiently.</li></ul>

#### ■ Warning related to rotating objects

<b>⚠ WARNING</b>	
	<p>This symbol stands for a possible risk of cutting fingers or hand, or entanglement by rotating fan.</p> <p>The product contains a cooling fan that rotates during operation of the product.</p> <p>The fan can start and stop intermittently and without warning.</p> <ul style="list-style-type: none"><li>● DO NOT operate the product without cover panels fitted.</li></ul>

#### ■ Warning related to other general dangers

<b>⚠ WARNING</b>	
	<p>This symbol stands for general danger.</p> <p><b>Hazards Inside</b></p> <ul style="list-style-type: none"><li>Hot Surfaces Inside – See Hot Surface symbol</li><li>Rotating Fan Inside – See Rotating Fan symbol</li><li>Pressurized Sytem Inside – The product contains pressurised fluid systems.</li></ul> <ul style="list-style-type: none"><li>● DO NOT operate the product without cover panels fitted.</li></ul>

### 1.3.4 Locations of Hazard Labels

There are various warning labels on the product to show the potential hazards.( Air-cooled refrigeration only)

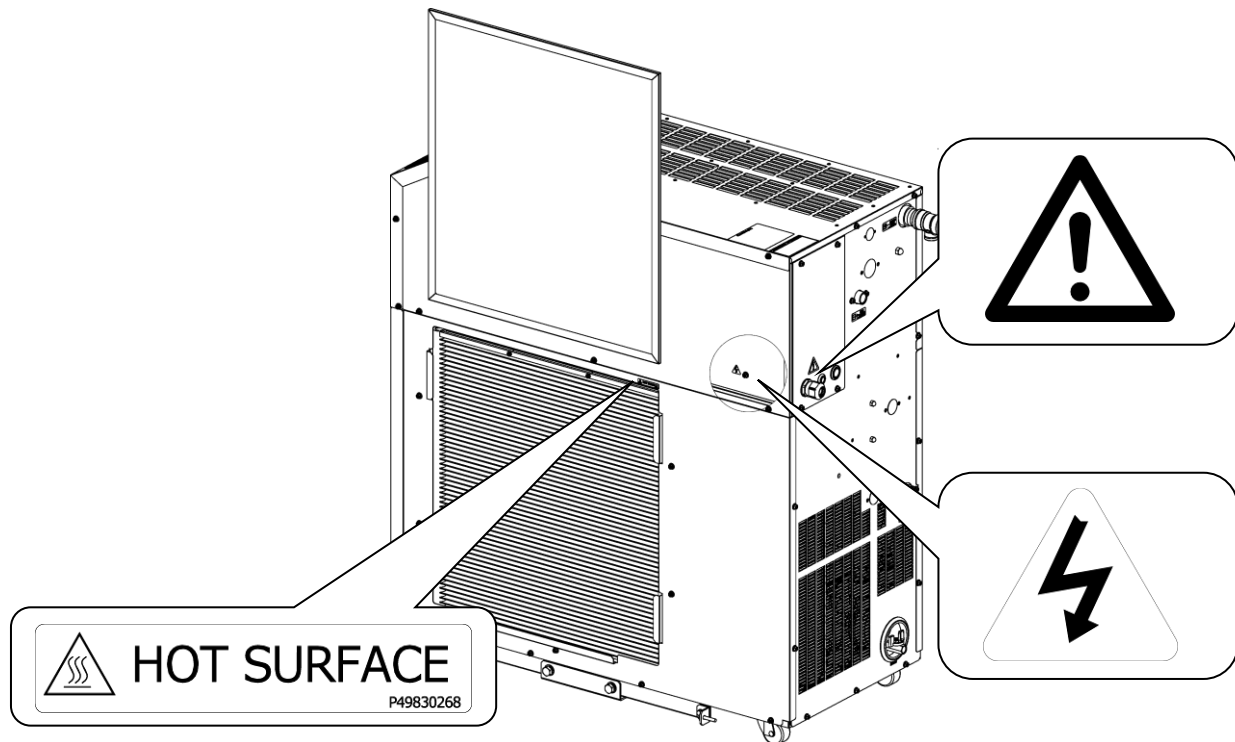

Fig. 1-1 Warning label position(1/2)

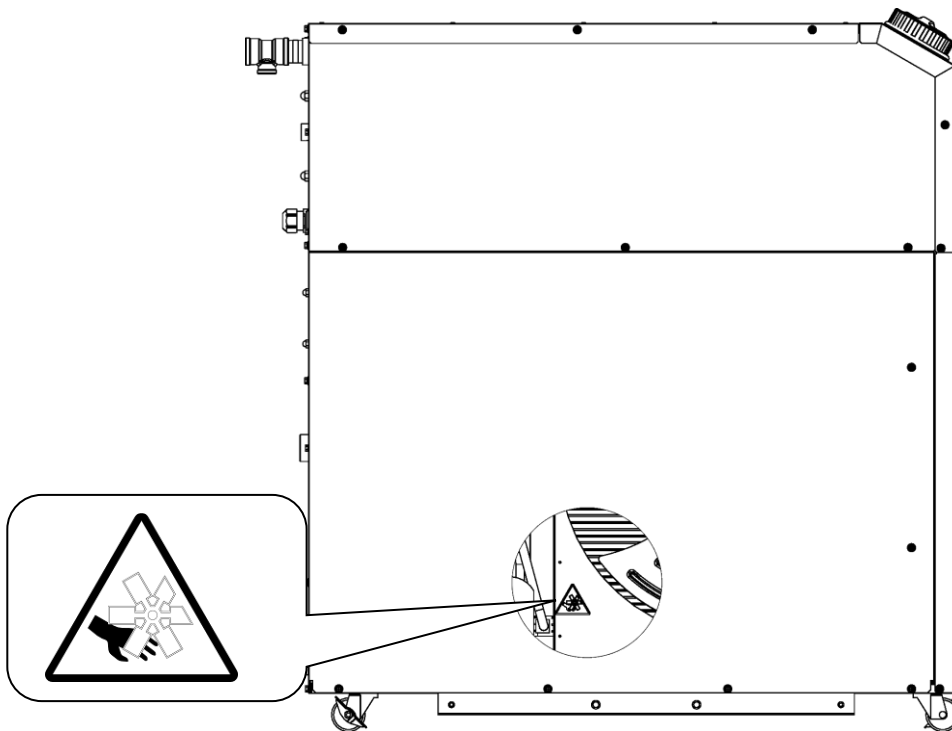
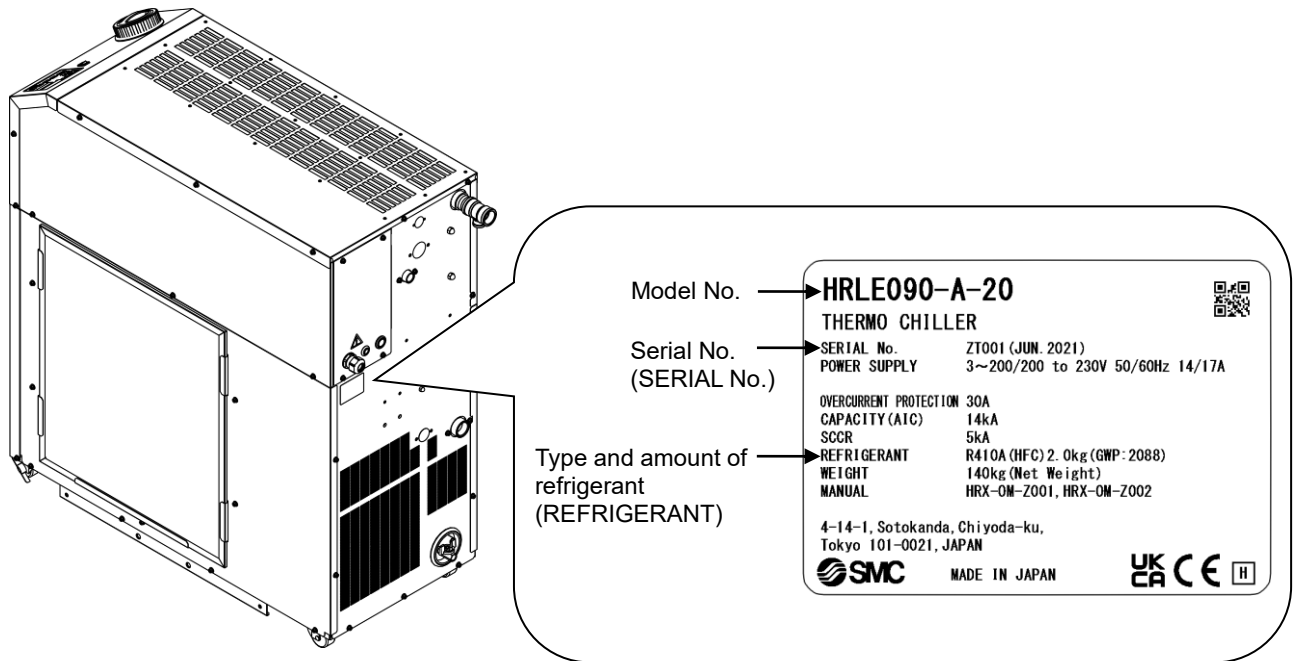

Fig. 1-2 Warning label position(2/2)

## 1.4 Product Label

The product's Model No. and Serial No. are needed when contacting a SMC sales distributor. The Model No. and Serial No. can be found on the product label.



### How to read the serial number Zo 001 (January 2021)

Z			o			001
Year	Symbol	Remarks	Month	Symbol	Remarks	Serial No.
2021	Z	Repeated from A to Z in alphabetical order (i, o, y are small characters).	1	o	Repeated from A to Z in alphabetical order with o assigned for January and Z for December (i, o, y are small characters).	-
2022	A		2	P		
2023	B		3	Q		
↓	↓		↓	↓		

Fig. 1-3 Position of the product label

## 1.5 Safety Measures

### 1.5.1 Safety instructions for use

#### **WARNING**



**Follow the instructions below when using the product. Failure to follow the instructions may cause an accident or injury.**

- Read and understand this manual carefully before using the product.
- In operating the product during maintenance, be sure to inform all workers nearby.
- Before starting maintenance of the product, be sure to lock out and tag out the breaker of the user's power supply.
- Use only the correct tools and procedure when using the product.
- Use personal protective equipment correctly as specified in "1.5.2 Personal protective equipment".
- Check that all parts and screws are correctly and securely restored to their original positions after finishing your work.
- Avoid working while intoxicated or sick, which might cause an accident.
- Do not remove the panels except for the cases permitted in this manual.
- Do not remove the panels during operation.
- Do not handle this product in any way other than that specified in this Operation Manual. Doing so can result in damage to the product or fire.

## **WARNING**



1. The compatibility of the product is the responsibility of the person who designs the equipment or decides its specifications. Since the product specified here is used under various operating conditions, its compatibility with specific equipment must be decided by the person who designs the equipment or decides its specifications based on necessary analysis and test results. The expected performance and safety assurance of the equipment will be the responsibility of the person who has determined its compatibility with the product. This person should also continuously review all specifications of the product referring to its latest catalog information, with a view to giving due consideration to any possibility of equipment failure when configuring the equipment.

2. Only personnel with appropriate training should operate machinery and equipment. The product specified here may become unsafe if handled incorrectly. The assembly, operation and maintenance of machines or equipment including our products must be performed by an operator who is appropriately trained and experienced.

3. Our products cannot be used beyond their specifications. Our products are not developed, designed, and manufactured to be used under the following conditions or environments. Use under such conditions or environments is not covered.

**A:** Conditions and environments outside of the given specifications, or use outdoors or in a place exposed to direct sunlight.

**B:** Use for nuclear power, railways, aviation, space equipment, ships, vehicles, military application, equipment affecting human life, body, and property, fuel equipment, entertainment equipment, emergency shut-off circuits, press clutches, brake circuits, safety equipment, etc., and use for applications that do not conform to standard specifications such as catalogs and operation manuals.

**C:** Use for interlock circuits, except for use with double interlock such as installing a mechanical protection function in case of failure. Please periodically inspect the product to confirm that the product is operating properly.

## **CAUTION**



We develop, design, and manufacture our products to be used for automatic control equipment, and provide them for peaceful use in manufacturing business.

Use in non-manufacturing business is not covered.

Products we manufacture and sell cannot be used for the purpose of transactions or certification specified in the Measurement Act.

The new Measurement Act prohibits use of any unit other than SI units in Japan.

## 1.5.2 Personal protective equipment

This manual specifies personal protective equipment for each task.

### ■ Transport, Installing, and Uninstalling

#### CAUTION



Always use safety shoes, protective gloves, and a helmet when operating the product.

### ■ Handling of circulating fluid

#### CAUTION



Always use safety shoes, protective gloves, mask, apron, and eye protection when handling the circulating fluid.

### ■ Operation

#### CAUTION



Always use safety shoes, protective gloves, and a helmet when operating the product.

## 1.6 Emergency Measures

When emergency conditions such as natural disaster, fire, earthquake and injury occur, shut off the breaker of the user's power supply that supplies power to the product.

### **WARNING**



**Even when the power supply switch is turned off, some of the internal circuits are still energized unless the user's power supply is shut off. Be sure to shut off the breaker of the user's power supply.**

## 1.7 Waste Disposal

### 1.7.1 Disposal of refrigerant and compressor oil

- The product uses a hydrofluorocarbon refrigerant (HFC) and compressor oil. Comply with the laws and regulations in each country for the disposal of refrigerant and compressor oil.
- The type and quantity of refrigerant is described on the product label. See "1.4 Product Label".
- If these fluids need to be recovered, carefully read and understand the instructions below. If there are any unclear points, contact an SMC's sales distributor.

### **WARNING**



- **Only maintenance personnel or qualified people are allowed to open the cover panels of the product.**
- **Do not mix the compressor oil with domestic waste for disposal. Also, waste disposal must only be conducted by specific facilities that have a permit for that purpose.**

### **WARNING**



- **Comply with the laws and regulations in each country for the disposal of refrigerant and compressor oil.**
- **It is strictly prohibited by law to emit fluorocarbons into the atmosphere. Refrigerant should be collected with special equipment. Then, contact a refrigerant recovery company to dispose of the collected refrigerant.**
- **Only people who have sufficient knowledge and experience with the product and its accessories are allowed to recover the refrigerant and compressor oil.**

### 1.7.2 Disposal of the product

The disposal of the product must be handled by a specialized industrial waste disposal agency in accordance with local laws and regulations.

## 1.8 Safety Data Sheet (SDS)

If the safety data sheets of chemicals used in this product are needed, contact an SMC's sales distributor.

Any chemicals used by the user must be accompanied by an SDS.



# Chapter 2 Names and Functions of Parts

## 2.1 Name of Each Part

### 2.1.1 HRLE050-A-20-\*(In case of Air-cooled refrigeration)

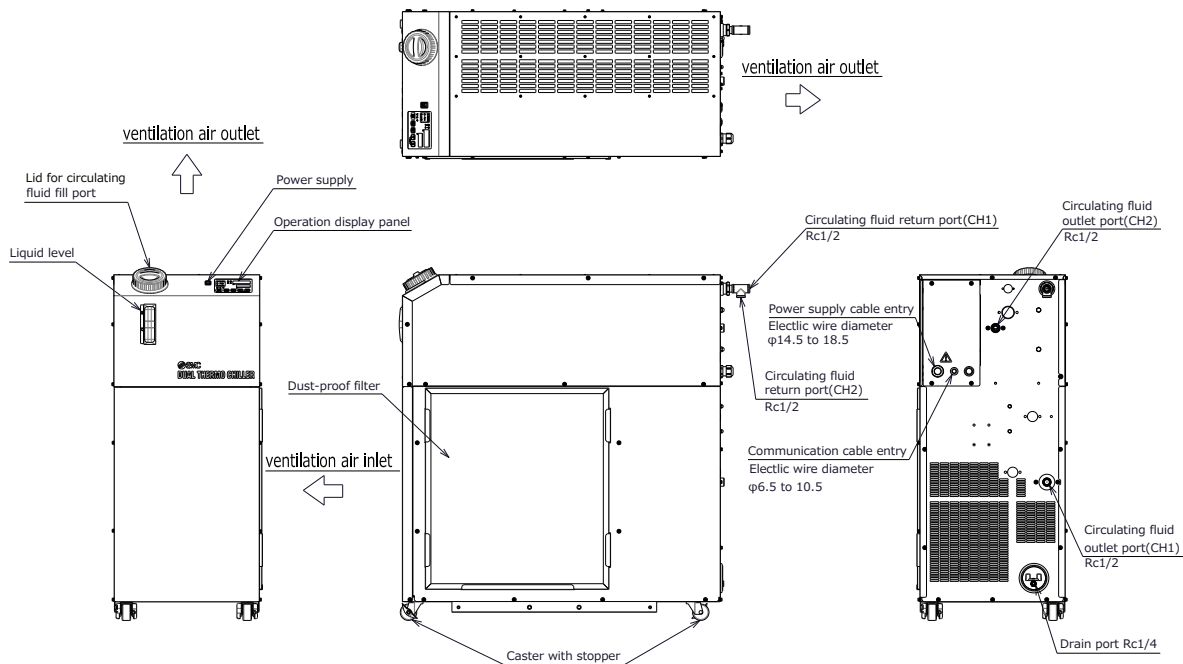

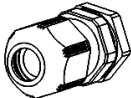
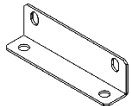

Fig. 2-1 Name of each part

Table 2-1 Accessories

①	Operation Manual	2 copy (English 1 pc. / Japanese 1 pc.)	
②	Cable accessory *Use this function when using the communication function.	1 pc.	
③	Anchor brackets *The anchor bolts are not attached.	2 pcs.	

## 2.1.2 HRLE050-W-20-\*(In case of Water-cooled refrigeration)

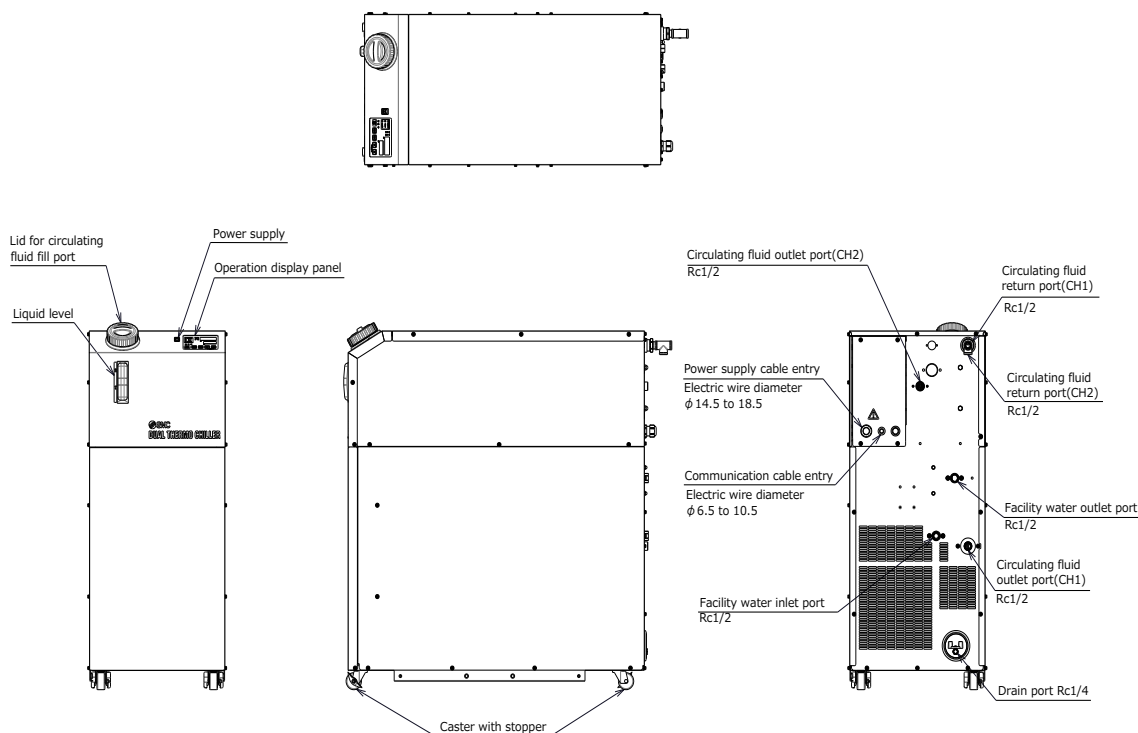

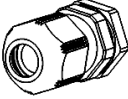
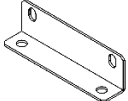

Fig. 2-2 Name of each part

Table 2-2 Accessories

①	Operation Manual	2 copy (English 1 pc. / Japanese 1 pc.)	
②	Cable accessory *Use this function when using the communication function.	1 pc.	
③	Anchor brackets *The anchor bolts are not attached.	2 pcs.	

### 2.1.3 HRLE090-A-20/40-\*(In case of Air-cooled refrigeration)

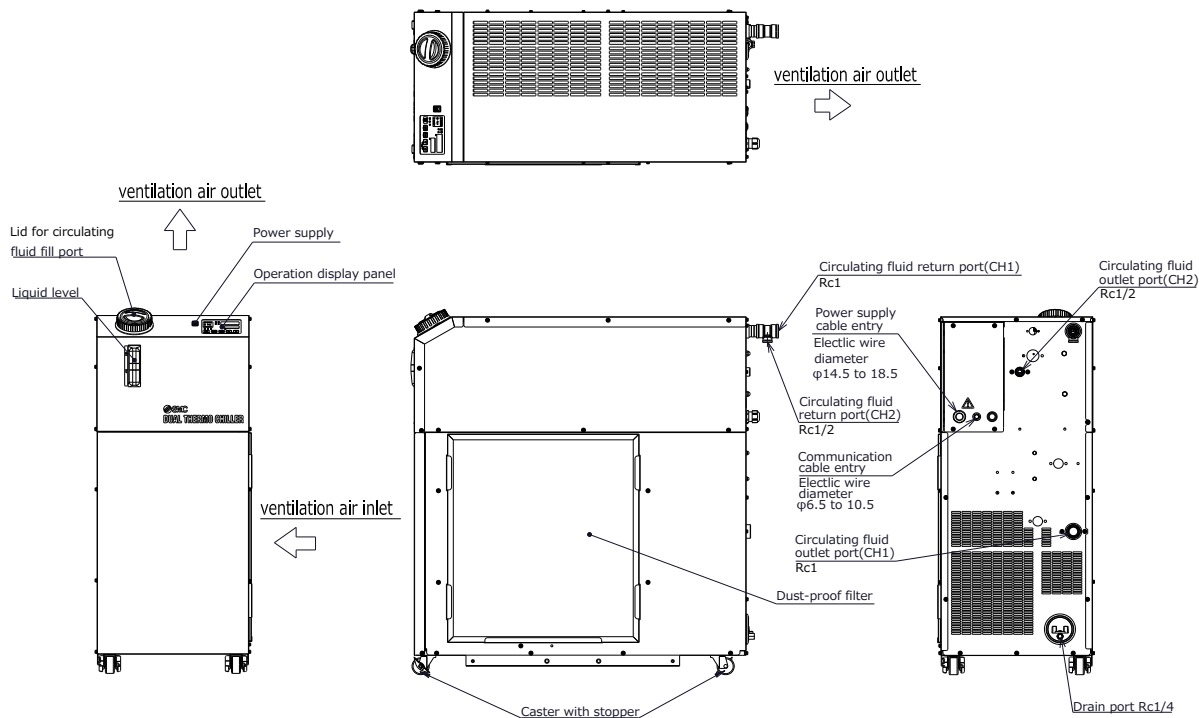

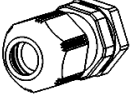
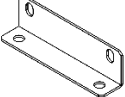

Fig. 2-3 Name of each part

Table 2-3 Accessories

①	Operation Manual	2 copy (English 1 pc. / Japanese 1 pc.)	
②	Cable accessory *Use this function when using the communication function.	1 pc.	
③	Anchor brackets *The anchor bolts are not attached.	2 pcs.	

### 2.1.4 HRLE090-W-20/40-\*(In case of Water-cooled refrigeration)

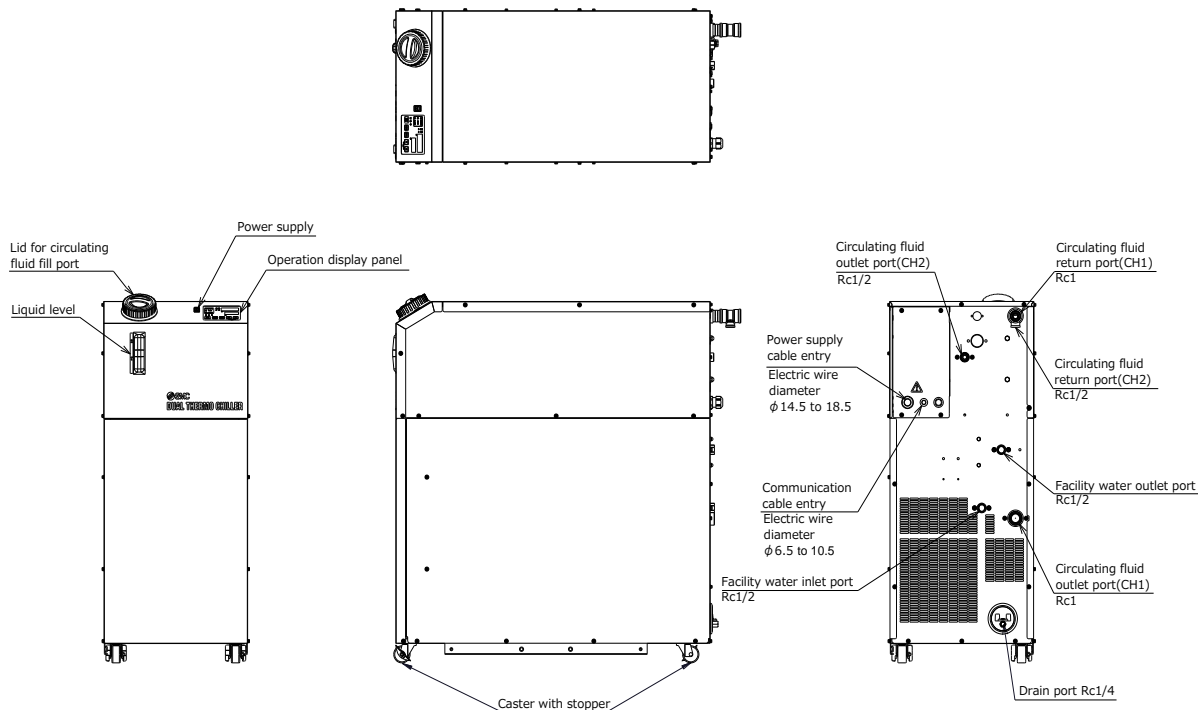

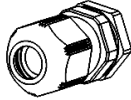
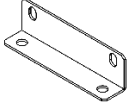

Fig. 2-4 Name of each part

Table 2-4 Accessories

①	Operation Manual	2 copy (English 1 pc. / Japanese 1 pc.)	
②	Cable accessory *Use this function when using the communication function.	1 pc.	
③	Anchor brackets *The anchor bolts are not attached.	2 pcs.	

## 2.2 Function of Each Part

The function of each part is as follows.

Table 2-5 Function of each part

Name	Function
Power supply switch	Power ON / OFF of the product.
Operation display panel	Runs and stops the product and performs settings such as for the circulating fluid temperature. For details, refer to "2.3 Operation Panel".
Fluid level gauge	Indicates the circulating fluid level of the tank. Confirm the level is between "H" and "L". For details, refer to "3.5 Circulating Fluid Supply".
Product Label	Shows the product information such as model number and serial number. For details, refer to "1.4 Product Label".
Circulating fluid outlet port	The circulating fluid is discharged from the outlet port.
Circulating fluid return port	The circulating fluid returns to the return port.
Drain port	This drain port is for draining the circulating fluid in the tank and pump.
Dust-proof filter	Inserted to prevent dust or contamination from getting directly on the Air-cooled condensers. Clean the filter periodically. For details, refer to "0 Monthly check".
Power cable entry	Insert the power cable into the power cable entry and connect it to the breaker. For details, refer to "3.3.2 Electrical wiring" and "3.3.3 Preparation and wiring of power supply cable".
Communication cable entry	Insert the communication cable into the communication cable entry and connect it to the communication terminal. Refer to "3.3.4 Preparation and wiring of communication cable".
Communication terminal	
Facility water inlet port	Supply facility water to inlet port.
Facility water outlet port	Facility water out from outlet port and return to customer's facility water system.

## 2.3 Operation Panel

The operation display panel on the front of the product controls the basic operation of the product.

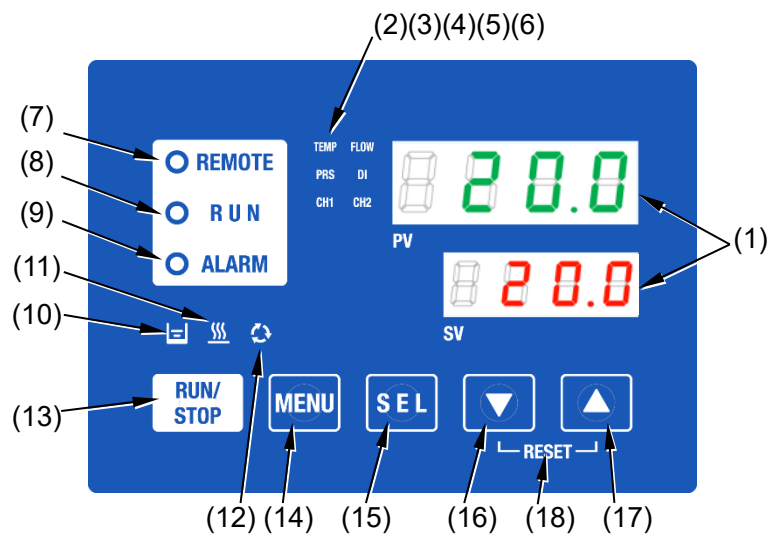





Fig. 2-5 Operating panel

Table 2-6 Operation panel

No.	Name	Function		Reference page
(1)	Digital display (7 segments, 4 digits)	PV Upper line	Displays the temperature and pressure of the circulating fluid, alarm codes and other menu items (codes).	Chapter 5.3
		SV Lower line	Displays the set temperature of the circulating fluid and the set values of other menu items.	
(2)	[TEMP] light	Turns ON when the temperature is indicated by (1). The indicated value is in (°C).		Chapter 5.3
(3)	[PRS] light	Turns ON when the pressure is indicated by (1). The indicated value is in (MPa).		Chapter 5.3
(4)	[FLOW] light	Not used in this product.		-
(5)	[DI] light	Turns ON when Electric conductivity is indicated by (1). The indicated value is in (µS/cm).		Chapter 5.3
(6)	[CH1/CH2] light	Turns on the CH that is digitally displayed.		Chapter 5.3
(7)	[REMOTE] light	Allows remote operation (start and stop) via the communication function. Turns ON when operation mode is set to DIO or SERIAL.		Chapter 5.8
(8)	[RUN] light	Turns ON when the product is started and in operation. Turns OFF when the product is stopped. Blinks during stand-by for stop or during anti-freezing operation		Chapter 4.3
(9)	[ALARM] light	Blinks with an alarm sound if an alarm should occur.		Chapter 5.4
(10)	[  ] light	Turns ON when the fluid level lowers below the "L" (low) level.		Chapter 3.5
(11)	[  ] light	Turns ON when the anti-freezing function is enabled. The [RUN] light (8) blinks during anti-freezing operation.		Chapter 5.6
(12)	[  ] light	Not used in this product.		-
(13)	[RUN/STOP] key	Makes the product start or stop.		Chapter 4.3
(14)	[MENU] key	Goes from the main menu (display screen showing circulating fluid temperature, pressure, etc.) to the other menus (entry of setting values and monitor screens).		Chapter 5.2
(15)	[SEL] key	Changes the items in a menu and enters the value of a setting.		
(16)	[▼] key	Decreases the set value.		-
(17)	[▲] key	Increases the set value.		
(18)	[RESET] key	Press the [▼] and [▲] keys simultaneously. This will stop the alarm sound and turn OFF the "ALARM" light.		Chapter 7.3

## Chapter 3 Transport and Set Up

### **WARNING**



- Only people who have sufficient knowledge and experience with the product and system are allowed to transport and set up the product.

### 3.1 Transport

The product is heavy and poses a danger when being transported. To prevent damage to the product, be sure to follow the instructions shown below for transport.

### **WARNING**



- When moving the product with a forklift, insert the fork into the right positions by referring to "3.1.1 Transportation using a forklift and slinging".
- Moving by forklift or slinging should be done by licensed persons.

### **CAUTION**



Never lay the product on its side.  
The compressor oil will leak into the refrigerant piping, which may cause failure of the compressor because of the lack of lubricating oil.

### **CAUTION**



- When the product is carried by using a forklift, make sure that the fork does not damage the cover panel or piping port.

### **CAUTION**



- Drain as much of the residual fluid from the piping as possible. The residual fluid may spill.

### 3.1.1 Transportation using a forklift and slinging

#### **⚠ WARNING**



- This is a heavy product. (Weight: About 140kg)
- Moving the Thermo-chiller by forklift or slinging should be done by licensed persons.

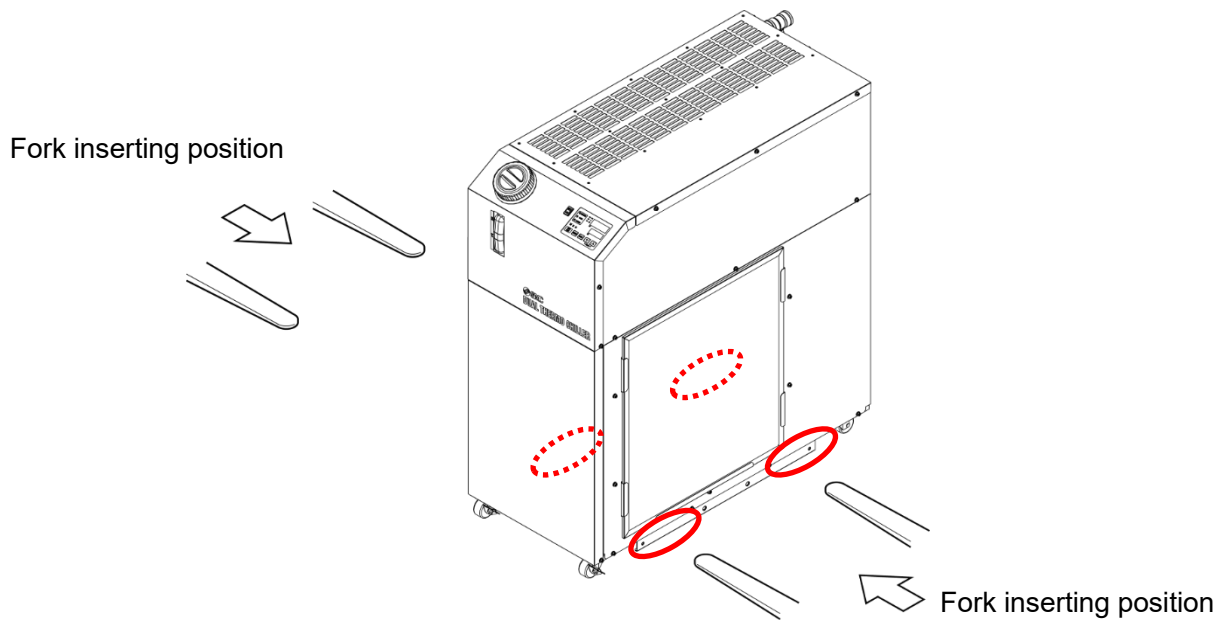

Fig. 3-1 Fork inserting and slinging positions

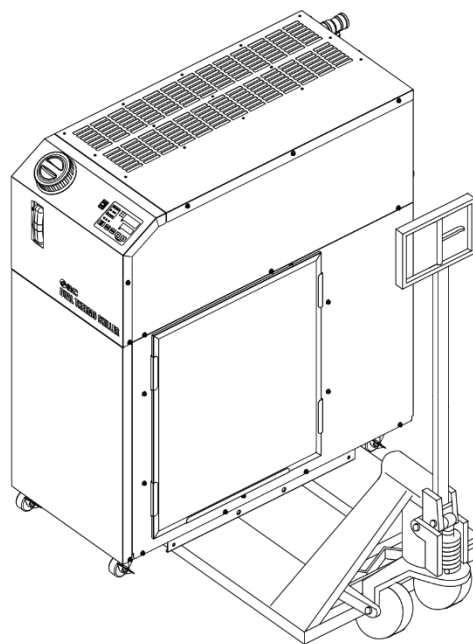

Fig. 3-2 Transport by handlift



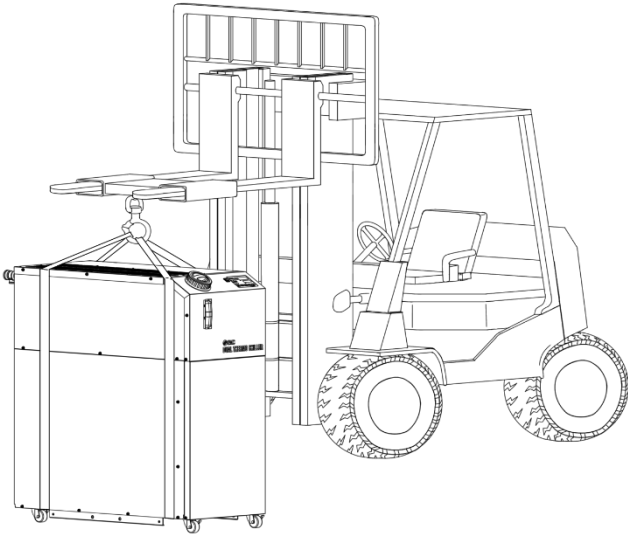

Fig. 3-3 Fork slinging position

### 3.1.2 Transportation using casters

**WARNING**



- This is a heavy product. (Weight: About 140kg)
- Moving the product on casters should be done by at least 2 people. Use special caution during transportation when the floor is on an incline.

**CAUTION**



Release the caster lock and push the corner of the product. Do not grip the piping or the handles of the panel, as it may cause damage to the product.

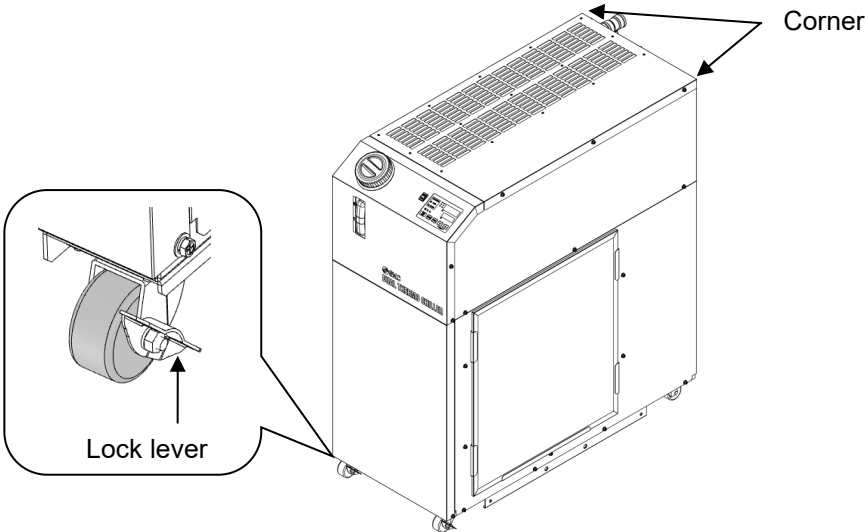



Fig. 3-4 Transportation using casters

## 3.2 Installation

<b>⚠ WARNING</b>	
	<ul style="list-style-type: none"> <li>● Do not set up the product in places possibly exposed to leakage of flammable gas. Should any flammable gas get near the product, the product may cause a fire.</li> </ul>

<b>CAUTION</b>	
	<ul style="list-style-type: none"> <li>● Keep the product upright on a rigid and flat floor which can support the weight of the product, and take measures to prevent the product from tipping over. Improper installation may cause water leakage, tipping, damage to the product or injure the operator.</li> <li>● Keep the ambient temperature of the product between 2 to 45 °C. Operation outside of this ambient temperature range may cause a malfunction of the product. Operating the product in an ambient temperature of 45 °C or higher may reduce the heat discharging efficiency of the heat exchanger and the safety device may trigger, resulting in the product stopping.</li> <li>● The installer/end user is responsible for carrying out an acoustic noise risk assessment on the equipment after installation and taking appropriate measures as required.</li> </ul>

### 3.2.1 Environment

The product must be operated or stored in the following conditions. Potential malfunction or damage to the product may occur if these instructions are disregarded.

This product is not designed for clean room usage. The pump and ventilating fan inside the product generate particles.

- (1) Locations where there is not liquid that exceeds the conditions required for the degrees of protection IPX4 may splash on the product.
- (2) Locations where the product is not subject to dust, salt water, oil, steam, etc.
- (3) Locations where there are no particles or dust.
- (4) Locations where there are no corrosive gases, solvents or combustible gases. (The product is not explosion-proof.)
- (5) Locations that are not exposed to direct sunlight or heat radiation.
- (6) Locations where the ambient temperature is between 2 to 45 °C during operation.  
Places with an ambient humidity of 30-70%.
- (7) Locations where the ambient temperature is between 0 to 50 °C while the product is stored. (with no water or circulating fluid in the piping)
- (8) Locations where the temperature does not change substantially.
- (9) When water droplets form due to condensation, measures should be taken by the user.

- (10) Locations not subject to strong electromagnetic noise. (No intense electric fields, intense magnetic fields, or surges)
- (11) Locations not subject to static electric sparks, or places where static electricity cannot discharge to the product.
- (12) Locations where high frequencies are not generated.
- (13) Locations where damage does not occur due to lightning (surges).
- (14) Locations where the product will not be affected by strong vibrations or impacts.
- (15) Locations where a force strong enough to deform the product is not applied.
- (16) Locations where the product is not affected by exhaust air or exhaust heat from other equipment.
- (17) Locations where generated particles/heat from the product do not affect the surrounding environment or equipment.
- (18) Locations with adequate space for maintenance as required.  
(For the space for maintenance, refer to the Operation Manual.)

**■ Thermo-chiller installation at a high altitude of 1000 meters or more**

Because of the lower air density, the heat radiation efficiencies of the devices in the product will be lower at altitudes of 1000 m or higher. For this reason, the maximum ambient temperature for operation of the Thermo-chiller and the cooling capacity will be reduced.

For product installation at an altitude of 1000 meters or more, select a Thermo-chiller with the applicable capacity, referring to the table below.

- (1) Max. ambient temp.: Use the product in a lower ambient temperature than the described value at each altitude.
- (2) Cooling capacity correction coefficient: Coefficient used to calculate the cooling capacity at each altitude.

For product operation at an altitude of 1800 meters, "the cooling capacity at an altitude of 1800 meters" = "Cooling capacity at an altitude of 1000 meters" x 0.8.

Altitude [m]	(1) Max. ambient temp. [°C]	(2) Cooling capacity correction coefficient
Less than 1000 m	45	1.00
1000 m or more - Less than 1500 m	42	0.85
1500 m or more - Less than 2000 m	38	0.80
2000 m or more - Less than 2500 m	35	0.75
2500 m or more - Less than 3000 m	32	0.70

**3.2.2 Location**

<b>CAUTION</b>	
	<ul style="list-style-type: none"> <li>● Install the product only in a location that may be subject to any of the conditions in "3.2.1 Environment".</li> </ul>

<b>CAUTION</b>	
	<p><b>This product exhausts heat using the fan mounted to this product. If the product is operated with insufficient air ventilation, the internal temperature can exceed 45 °C, which can cause overloaded operation, which will affect the performance and life of the product. To prevent this, ensure that suitable ventilation is available (see below).</b></p>

**■ Installation of multiple products**

Keep sufficient space between products so that the air vented from one product will not be taken in by other products.

**■ Ventilation**

- ① For a facility having a large installation area (that can vent the air naturally):  
Make an air outlet in a wall at a high level and an air inlet in a wall at a low level to allow for adequate airflow.
- ② For a facility having a small installation area (that cannot vent the air naturally):  
Make a forced air exhaust vent in a wall at a high level and an air inlet in a wall at a low level.
- ③ Using a duct to exhaust the air:  
If the indoor site cannot accept the exhausted air from the product or it is air conditioned, ventilate by installing a duct on the ventilation air outlet of the product. Do not fasten the duct directly onto the ventilation air outlet of the product. Install it at least the duct's diameter away from the outlet.  
Use a fan for the duct for which the ventilation resistance of the duct has been considered.
- ④ Do not install it in an enclosed location.

Table 3-1 Amount of heat radiation and required ventilation

Model No.	Heat radiation kW	Required amount of ventilation [m <sup>3</sup> /min]	
		Differential temp. of 3 °C between the inside and outside of the installation area	Differential temp. of 6 °C between the inside and outside of the installation area
HRLE050-A-20-*	Approximately 10	140	70
HRLE090-A-20/40-*	Approximately 18	305	155

**CAUTION**



**The Water-cooled product radiates heat to the facility water. It is necessary to supply the facility water. Please prepare the facility water system that satisfies the heat radiation and the facility water specifications below.**

**■ Required facility water system**

Table 3-2 Heat radiation

Model	Heat radiation kW	Facility water specifications
HRLE050-W-20-*	Approx. 10	Refer to [9.1 Specifications].
HRLE090-W-*-*	Approx. 20	

**■ Installation environment specifications**

- Sound noise HRLE050-A-20 : 62/64 dB(A)
- HRLE050-W-20 : 62/64 dB(A)
- HRLE090-A-20 : 65 dB(A)
- HRLE090-A-40 : 67 dB(A)
- HRLE090-W-20/40 : 65 dB(A)

\* 1 m from the front surface, 1 m high from the floor, rated condition.

### 3.2.3 Installation and maintenance space

It is recommended to keep the space around the product shown in Fig. 3-3

**⚠ CAUTION**

**!** Make sure there is enough space for ventilation of the product. Otherwise it may cause a lack of cooling capacity or stoppage of the product. Ensure there is enough space for maintenance.

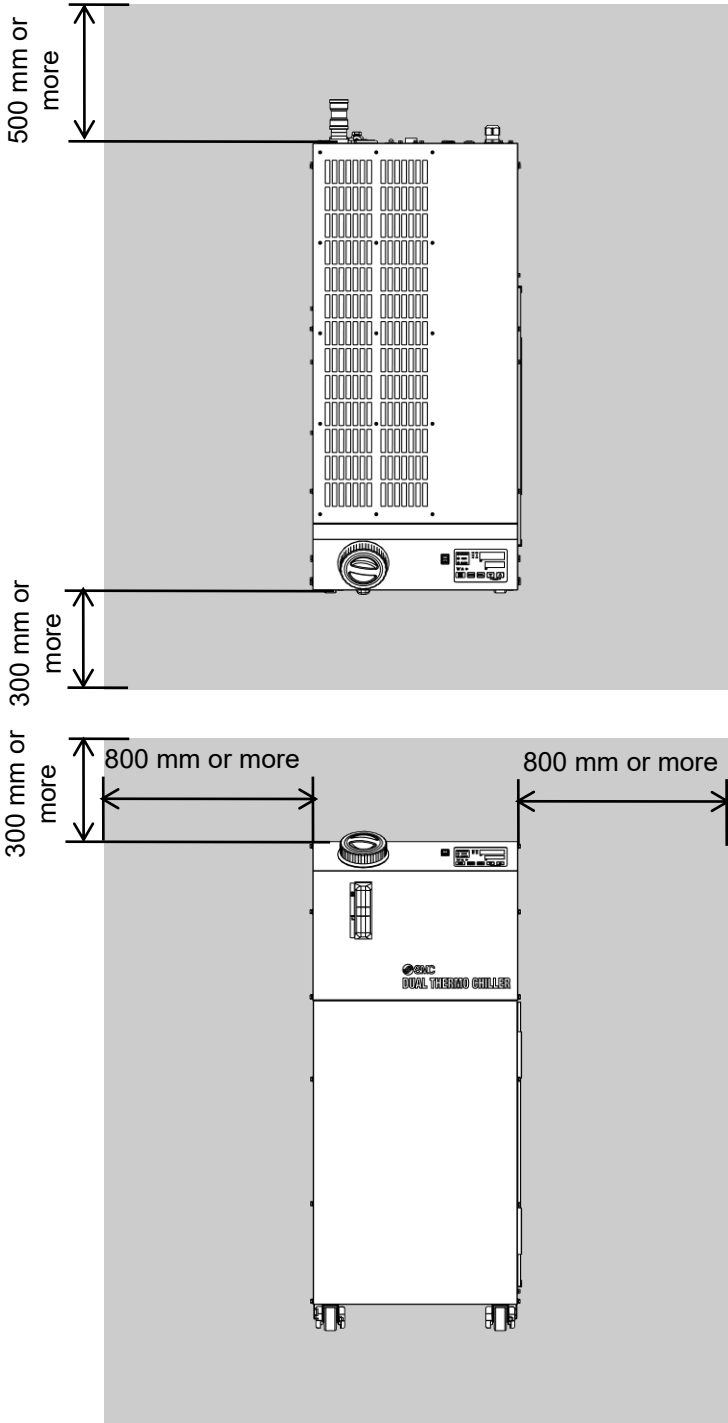

Fig. 3-5 Installation space

## 3.3 Installation Procedure

### 3.3.1 Installation procedure

#### **⚠ CAUTION**



Install the product on a level, vibration-free floor. Prepare M10 anchor bolts that are suitable for the material of the floor that the product will be installed on. Drive the anchor bolts in at least two places on the left and right sides of the product (four places in total). Refer to "9.3 Dimensions" for the dimensions for the positions of the anchor bolts.

#### ■ How to mount the product

**1.** Move the product to the installation area.

---

**2.** Lock all casters.

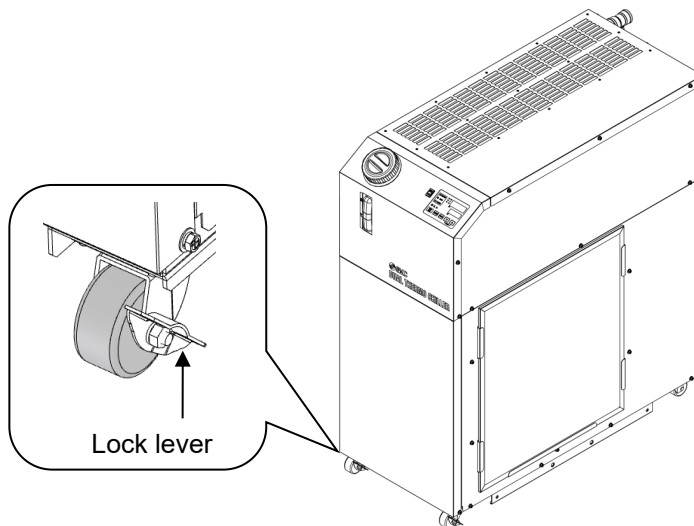

Fig. 3-6 Installation procedures

## ■ Fixture

Use the fixtures and holding screws currently used for holding the product to the wooden box to secure the product to the floor using anchor bolts.

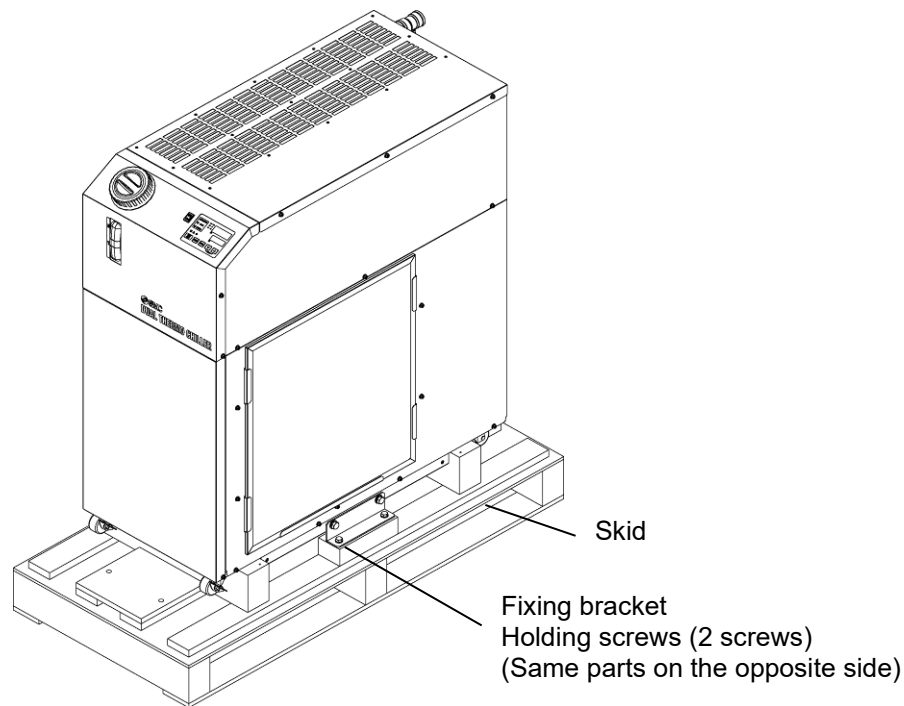

Fig. 3-7 Fixtures and holding screws

1. Install anchor bolts on a level floor with the dimensions below.

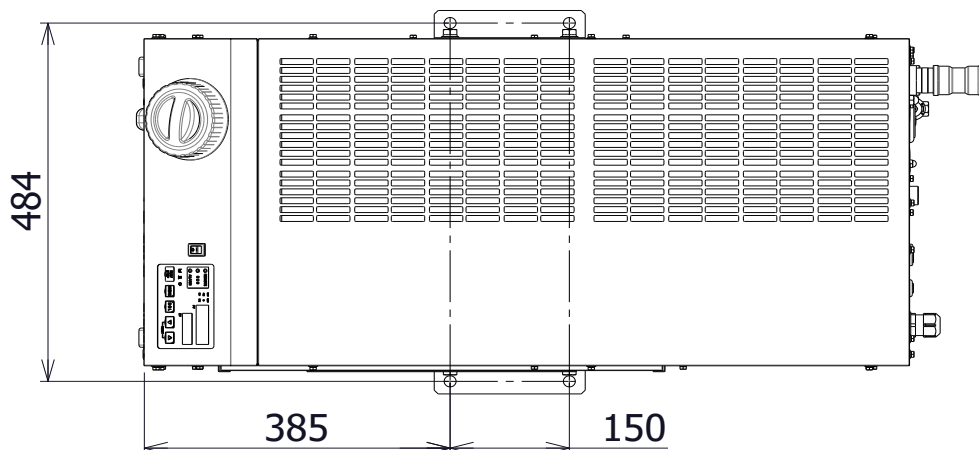

Fig. 3-8 Installation of anchor bolts

2. Set the fixtures from the top of the anchor bolts.

3. Set hexagon screws to the anchor bolts and screw the holding screws into the product to secure the product to the floor. The fixtures are mounted to the left and right surface of the product (2 places).

**[Note]**

SMC Foundations bolt set "IDF-AB500" (Stainless Steel M10 x 50 mm) is applicable. Please order separately.

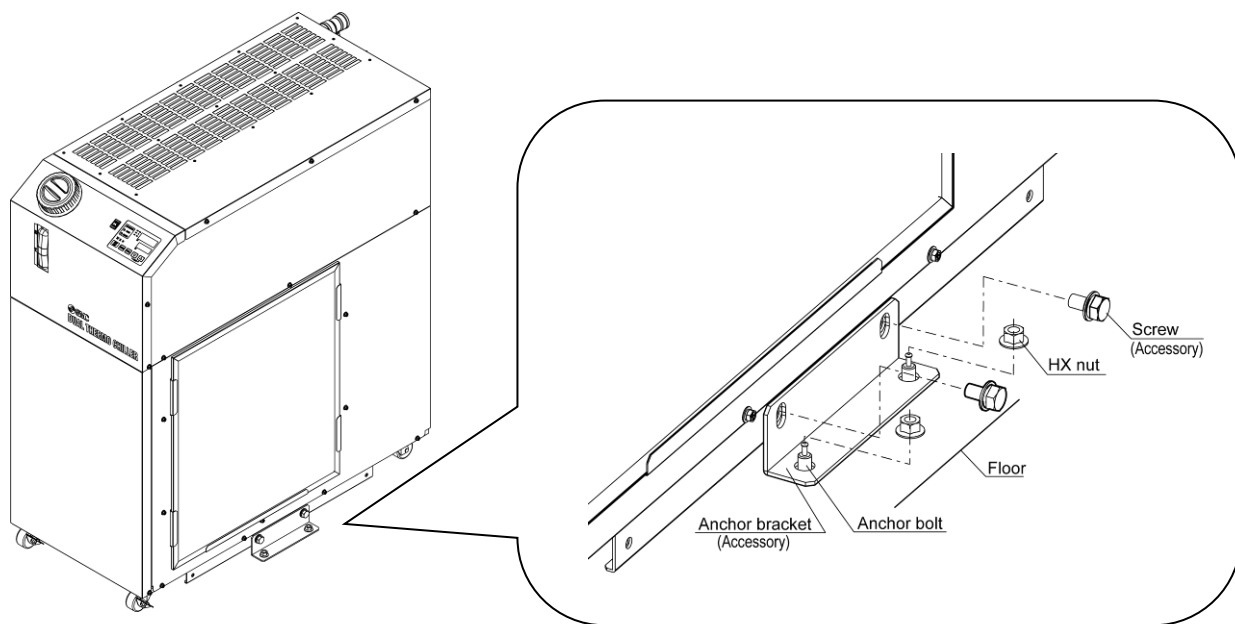

Fig. 3-9 Securing to the floor



### 3.3.2 Electrical wiring

#### **⚠ WARNING**



- Do not modify the internal electrical wiring of the product. Incorrect wiring may cause electric shock or fire. Also, modifying the internal wiring will void the product's warranty.
- NEVER connect the ground to a water line, gas pipe or lightning conductor.

#### **⚠ WARNING**



- The electrical facilities should be installed and wired in accordance with local laws and regulations of each country by a person who has knowledge and experience.
- Be sure to shut off the user's power supply before any wiring work. Wiring with the product energized is strictly prohibited.
- The wiring must be conducted using cables complying with " Table 3-3" and be firmly secured to the product to prevent the external force of the cables from being applied to the terminals. Incomplete wiring, or improper securing of wiring, may cause electric shock or excessive heat and fire.
- Ensure that an earth leakage breaker is used in the power supply of the product. See " Table 3-3".
- Use a power supply suitable for the specifications of the product. Use a power supply of overvoltage category 3 (IEC60664-1).
- Be sure to connect the ground connection.
- Ensure that a lock out facility is available on the power supply.
- Each product must have its own separate connection to the power supply. Mixing wiring with other equipment is risky and may cause electric shock or fire. Never attempt to do this.
- Ensure that no harmonics are superimposed on the power supply. (Do not use an inverter, etc.)
- Supply a steady power supply which is not affected by surges or distortion.  
In particular, if the voltage rise rate ( $dv/dt$ ) at zero crossing exceeds 40 V/200  $\mu$ sec, it may cause a malfunction.

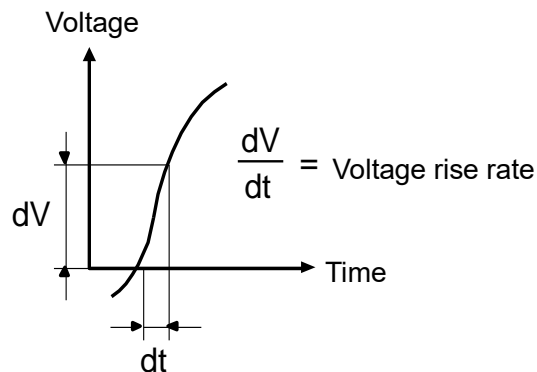

**■ Power supply specifications, power supply cable and earth leakage breaker**

Prepare the power supply shown in the following table. For the connection between the product and power supply, use the power supply cable and earth leakage breaker shown below. An earth leakage breaker must be mounted to a position where the breaker is easily accessible and close to the Thermo-chiller.

Table 3-3 Power supply cable and earth leakage (Recommended)

Model	Power supply voltage Specifications	Terminal block screw diameter	Recommended crimp terminal	Cable qty. x size	Earth leakage breaker	
					Rated current [A]	Sensitivity of leak current [mA]
HRLE050-※-20	Single phase AC200 to 230V(50/60Hz)	M5	R5.5-5	3 cores x 5.5 mm <sup>2</sup> (3 cores x AWG10) * including ground	30	30
HRLE090-※-20	3 phase 200VAC(50Hz) 3 phase 200 to 230VAC(60Hz)	M5	R5.5-5	4 cores x 5.5 mm <sup>2</sup> (4 cores x AWG10) * including ground	30	
HRLE090-※-40	3 phase 380 to 415VAC(50Hz/60Hz) 3 phase 460 to 480VAC(60Hz)	M8	R5.5-8		20	

\* Cable specifications are examples for when using the product at a continuous allowable operating temperature of 70 °C, with an operating voltage of 600 V and two kinds of plastic insulated wires at an ambient temperature of 30 °C. Please select the proper size cables according to the actual condition.

**■ Grounding**

Be sure to ground the product (PE). Do not share the ground with equipment that generates strong noise or high frequencies. Grounding class: D-class grounding (with a ground resistance of 100 Ω or less)

**3.3.3 Preparation and wiring of power supply cable**

**⚠ WARNING**



- **The electrical facilities should be installed and wired in accordance with local laws and regulations of each country by a person who has knowledge and experience.**
- **Check the power supply.**  
Operation with voltages, capacities and frequencies other than the specified values can cause fire and electric shock.
- **Wire with an applicable cable size and terminals. Forced mounting with a cable or terminals of an unsuitable size may result in heat generation or fire.**

**⚠ WARNING**



**Be sure to lock out and tag out the breaker of the facility power supply (user's power supply) before wirin.**

**⚠ WARNING**



Be sure to connect the power supply cable from the product side first, and then connect the breaker of the facility power supply (the user's power supply facility).

**⚠ CAUTION**



When the panel is removed or mounted, be sure to wear protective gloves to prevent injury with the edge of the panel.

**CAUTION**

**【HRLE050-\*-20】**

A breaker that has the operating characteristic shown below is installed. Please use a breaker that has the same or longer operating time for the customer side (upstream side). If it has a shorter operating time, there is a possibility of accidental breaker trip due to the internal motors' inrush currents of this product.

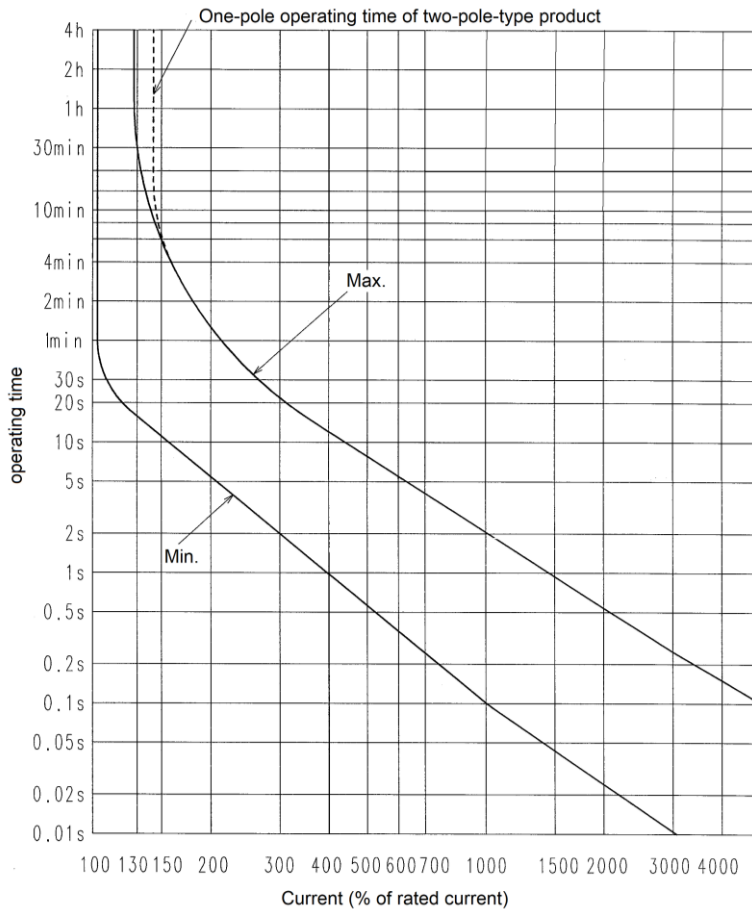

Operating characteristics of the breaker

### CAUTION

**【HRLE090-\*-20】**

A breaker that has the operating characteristic shown below is installed. Please use a breaker that has the same or longer operating time for the customer side (upstream side). If it has a shorter operating time, there is a possibility of accidental breaker trip due to the internal motors' inrush currents of this product.

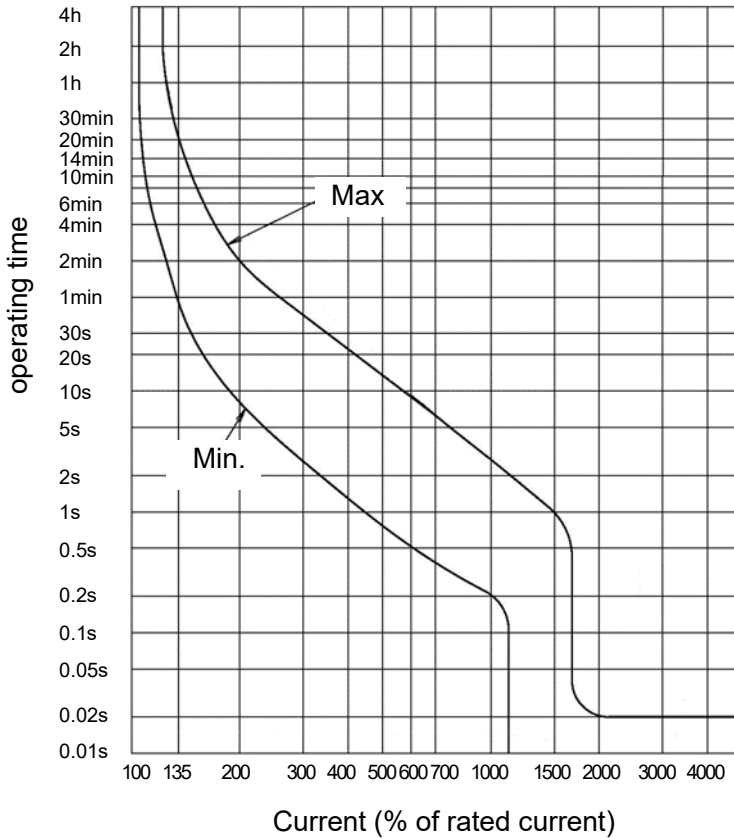

Operating characteristics of the breaker

■ Power supply cable wiring

- 1. Remove the 4 screws to allow removal of the power supply terminal cover on the back of the product.

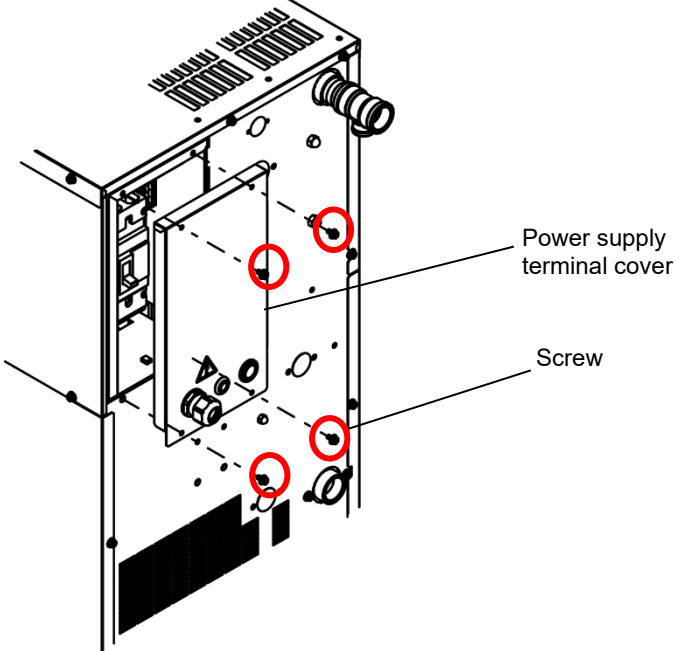

Fig. 3-10 Removal of power supply terminal cover

- 2. Insert the power supply cable and ground cable through the power supply cable entry of the power supply terminal cover (cable accessory).

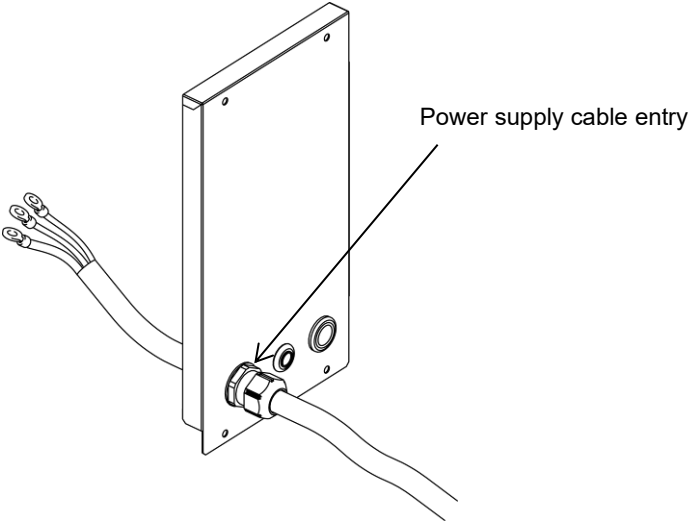
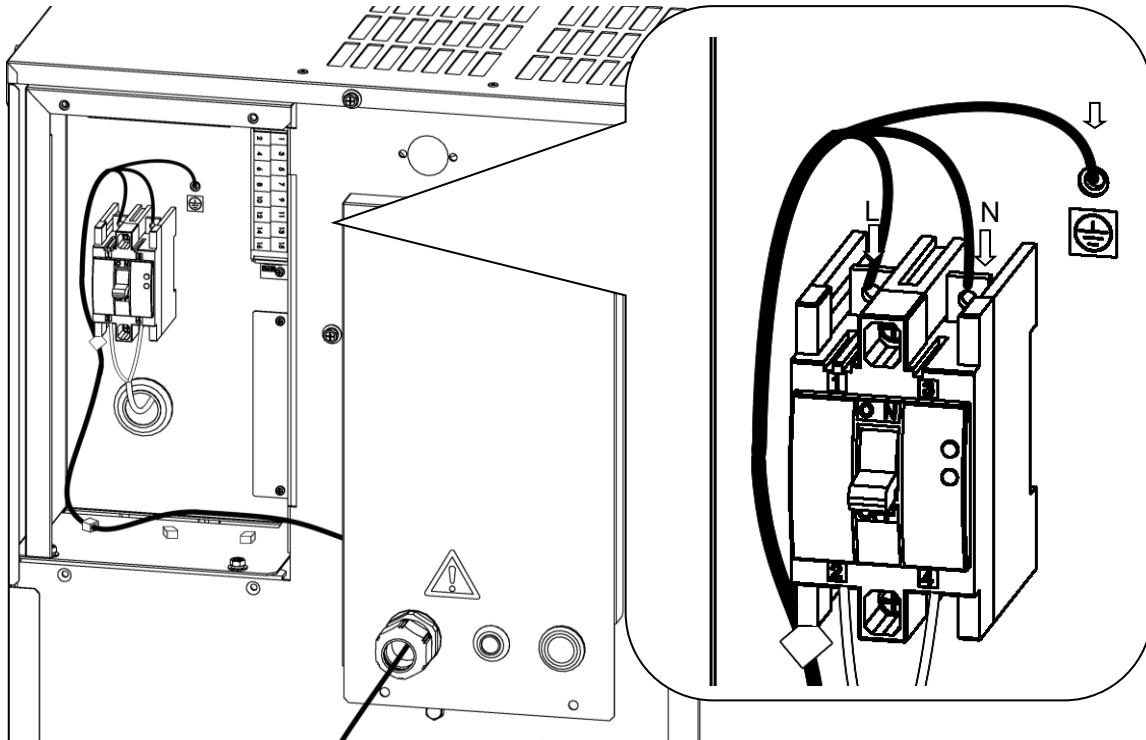

Fig. 3-11 Power supply cable entry

- 3.** Connect the power supply cable and ground wire as shown in the figure below.  
【HRLE050 200V】



【HRLE090 200V】

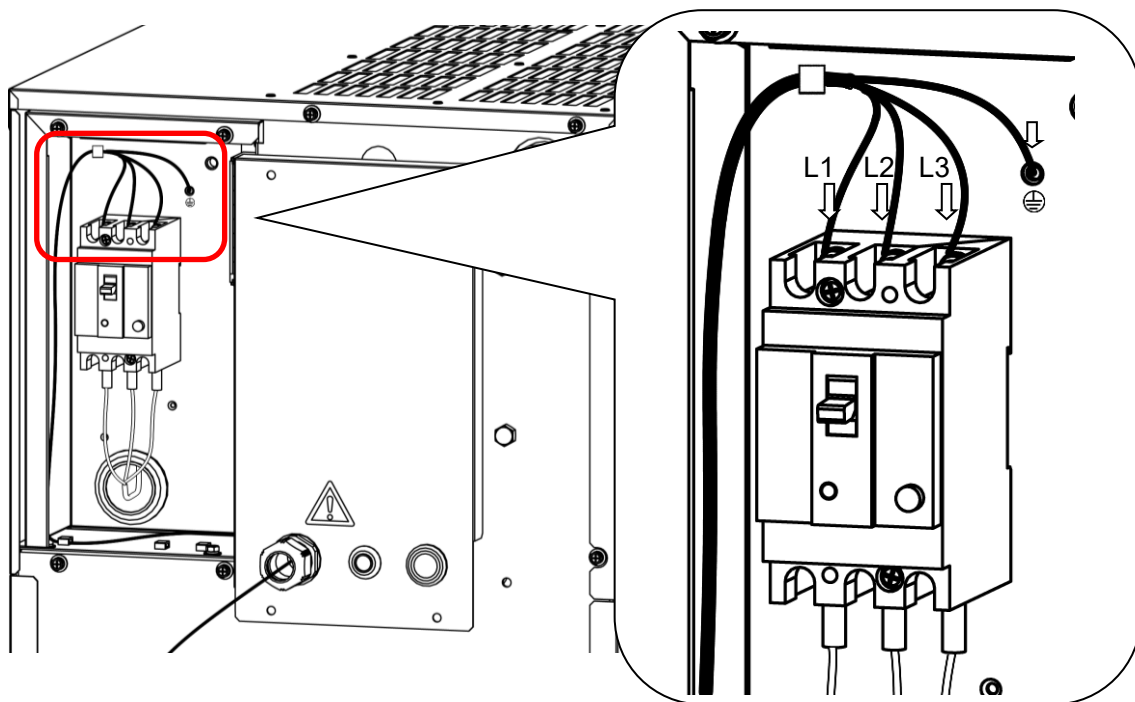

Fig. 3-12 Cable wiring (200V)

【400V】

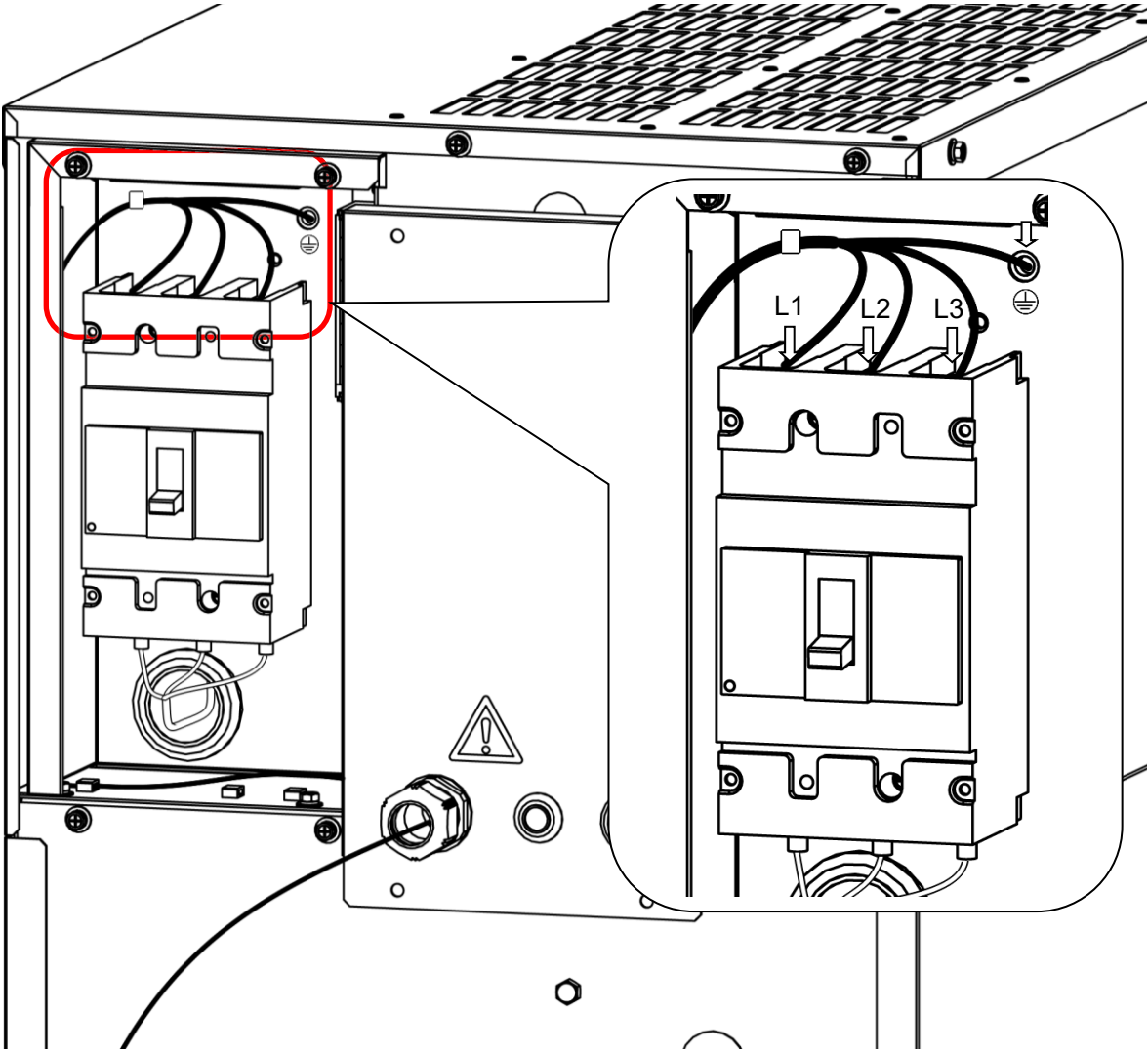

Fig. 3-13 Cable wiring (400V)

### 3.3.4 Preparation and wiring of communication cable

#### **WARNING**



Be sure to turn OFF the breaker of the facility power supply (the user's power supply facility) before wiring.

#### **CAUTION**

- Use the specified cables and terminals.
- Use an output contact for RUN/STOP and remote input signals (e.g., external switches) that has a sufficiently large capacity.

#### ■ Contact input/output

The product has a contact input/output communication function as shown below.

##### [Contact output]

- **Operation signal output:** Operation status signal is output.
- **TEMP READY signal output:** The signal is output when the Thermo-chiller's circulating fluid temperature is within the set range.

\* For the setting of the TEMP READY signal, refer to "5.6.4 Band width setting for the TEMP READY signal" and "5.6.5 Time setting for the TEMP READY signal for out of range".

- **Alarm signal output:** Outputs the signal when an alarm is generated.

##### [Contact input]

- **Run/stop signal input:** Switches the run/stop of the Thermo-chiller.
- **Energy saving mode input:** Switches between the high precision mode and energy saving mode.

\* In the energy saving mode, power consumption is reduced by stopping the refrigerant circuit while the load is low. Temperature stability: CH1: +0 to 5.0°C, CH2: ±5°C

Other functions, please refer to "Chapter 5 Display and Setting of Various Functions"

#### ■ Serial Communications

##### [Writing]

- **Writer RUN / STOP instructions:** Switches the RUN / STOP of the thermo-chiller.
- **Circulating fluid set temperature writing:** Changes the circulating fluid set

##### [Read]

- Reads the current temperature of the circulating fluid
- Reads the circulating fluid discharge pressure
- Reads alarm occurrence information
- Reads the status of this product



## ■ Communication cable and terminal block

This product uses the connector shown below as the connector for contact input/output communication.

Prepare a suitable connector cable.

Table 3-4 Communication cable and terminal block (Recommended)

Terminal specifications		Cable specifications
Terminal block screw diameter	Recommended crimp terminal	
M4	Y-shape crimped terminal 0.3Y-4N	0.3mm <sup>2</sup> (AWG22) Shielded cable

Table 3-5 Pin numbers

PIN No.	Application	Classification	Initial value (default setting)
1	COM of contact input signal	Input	-
2	Contact input signal 1	Input	Run/Stop signal
3	Contact input signal 2	Input	External switch signal
4	(None)	-	-
5	RS-485 Communication	SD+	-
6	RS-485 Communication	SD-	-
7	RS-485 Communication	SG	-
8	(None)	-	-
9	Contact output signal 1	Output	Operation status (A contact) (normally open)
10	COM of contact output signal 1	Output	-
11	Contact output signal 2	Output	Alarm signal (B contact) (normally close)
12	COM of contact output signal 2	Output	-
13	Contact output signal 3	Output	TEMP READY signal (A contact) (normally open)
14	COM of contact output signal 3	Output	-
15	24 VDC input	Output	-
16	24 COM input	Output	-

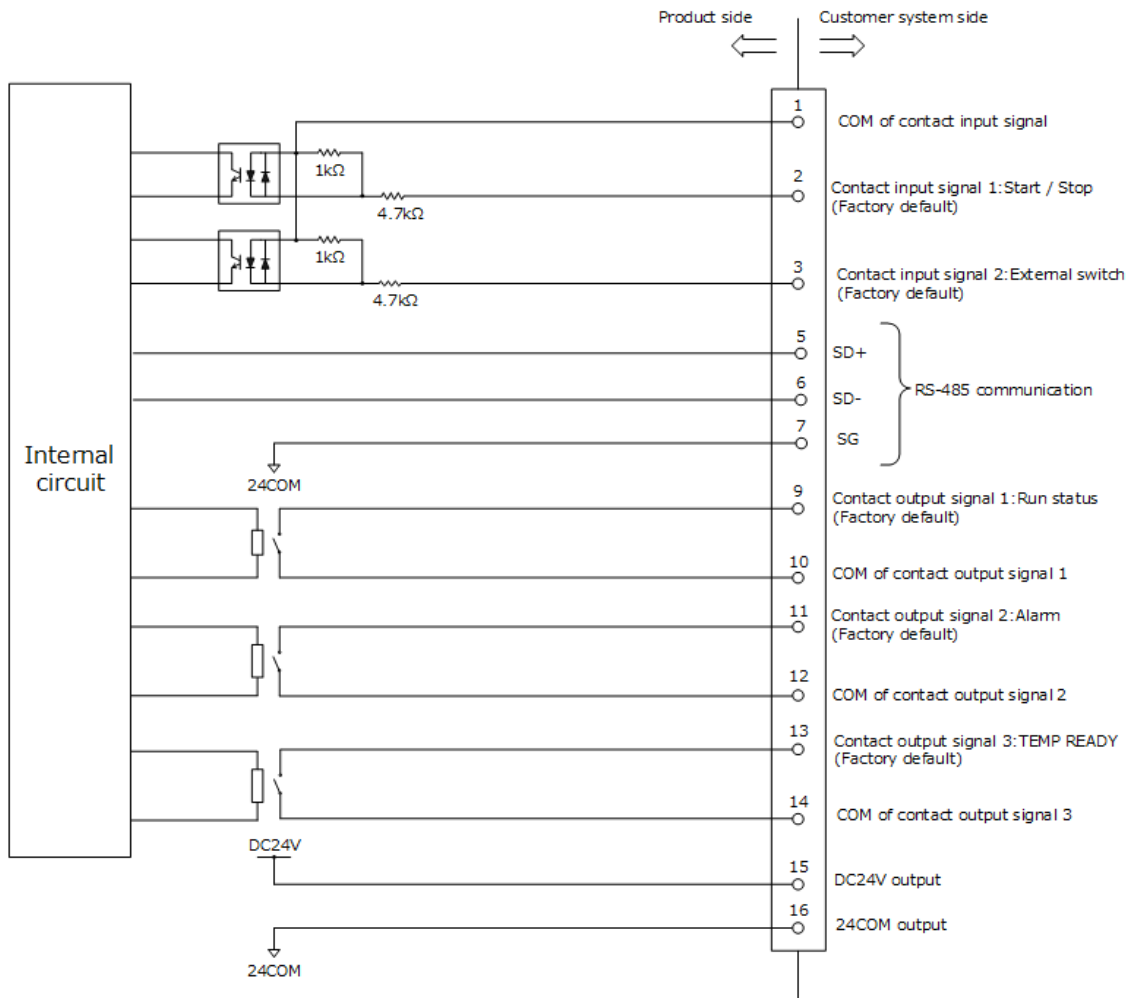

Fig. 3-14 Connector connection example

## ■ Contact input / output

Table 3-6 Contact input/output communication specifications

Items		Specifications	
Contact input signal 1,2	Insulation method	Photo coupler	
	Rated input voltage	24 VDC	
	Operating voltage range	21.6 VDC to 26.4 VDC	
	Rated input current	5 mA TYP	
	Input impedance	4.7 kΩ	
Contact output signal 1,2,3	Rated load voltage	48 VAC or less / 30 VDC or less	
	Maximum load current	AC/DC 500 Ma (Resistance load)	
	Minimum load current	5 VDC 10 mA	
24VDC output voltage	24VDC±10% 200mA MAX <sup>*1</sup> (Cannot be used for inductive loads.)		

\*1 Make sure that the total load current is 500mA or less. When using the power supply of this product, make sure that the total load current is 200mA or less.

\*2 Refer to 5.8 Communication Setting Menu

## ■ Serial communication

This product can remotely control the start / stop of operation, set and read the circulating fluid temperature, and read the status of this product and alarm status by serial communication.

Refer to Operation Manual Communication Function for more details.

### **WARNING**



**Be sure to turn OFF the breaker of the facility power supply (the user's power supply facility) before wiring.**

- Connecting to PC

RS-485 cannot be directly connected to a normal PC. Use a RS-485 converter which is available on the market.

Be sure to follow the wiring procedure shown below for connecting multiple thermo-chillers.

- Configuration of connection

One thermo-chiller for one host computer, or multiple thermo-chillers for one host computer.

(32 thermo-chillers can be connected at maximum.)

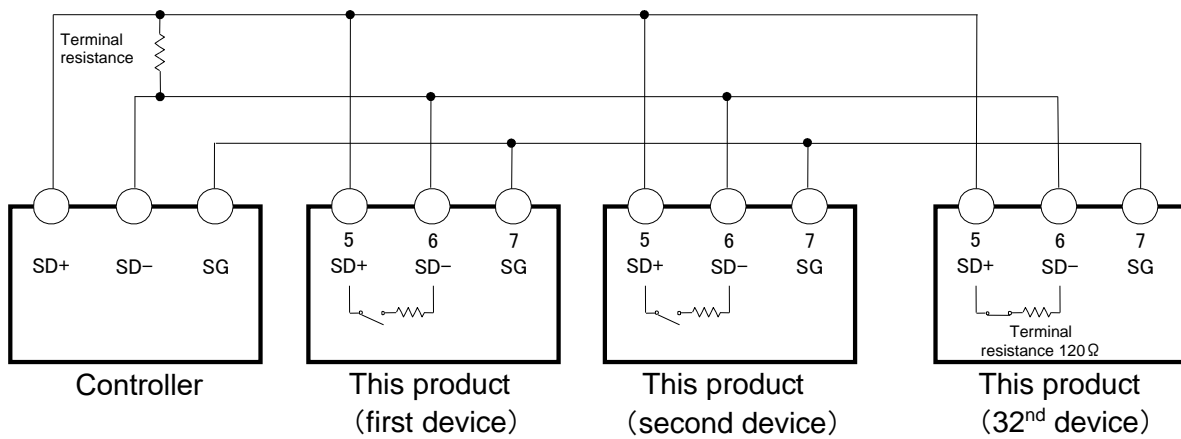

**Do not connect any wire to other PIN numbers.**

Fig. 3-15 Connection of RS-485

**[Tips]**

Both ends of the communication connection (the end nodes) need to be connected to the host computer.

With or without the terminating resistor of this product can be set by the operation display panel. Refer to “5.8.5 Serial communication termination resistance switching”.

■ **Communication cable wiring**

- 1.** Remove the grommet of the power terminal cover, install the cable accessory(accessory).
- 2.** Connect the communication cable to the terminal block.

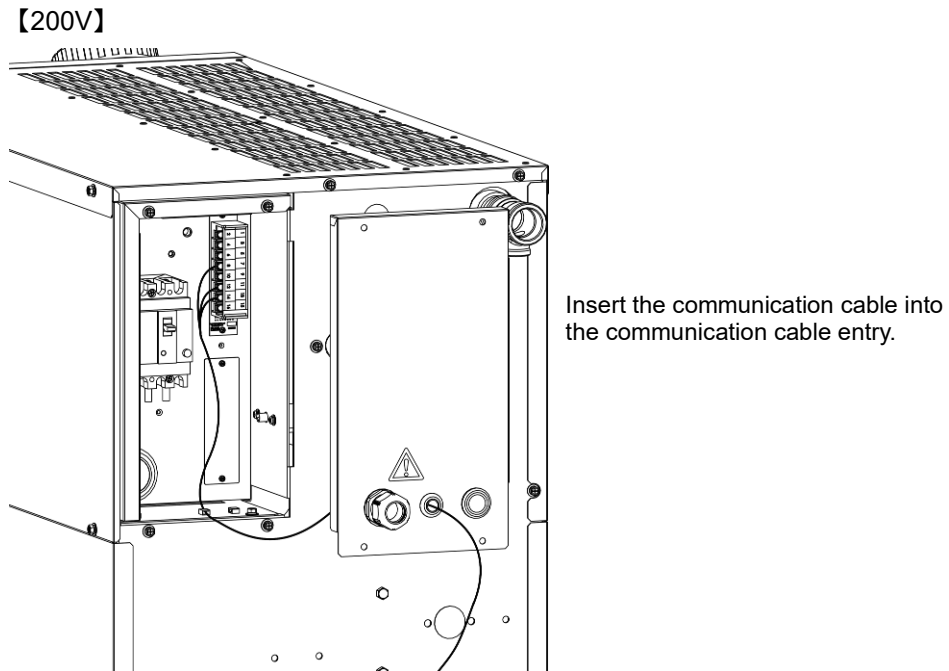

Fig. 3-16 Wiring for cable communication (200V)

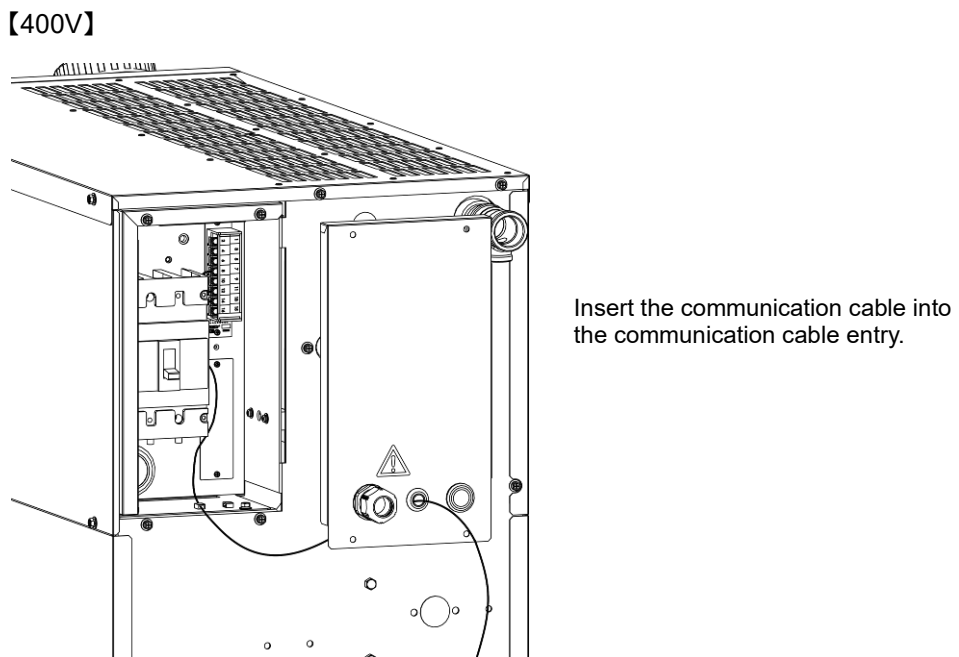

Fig. 3-17 Wiring for cable communication (400V)

**3.** Turn on the breaker switch located on the back of the product.

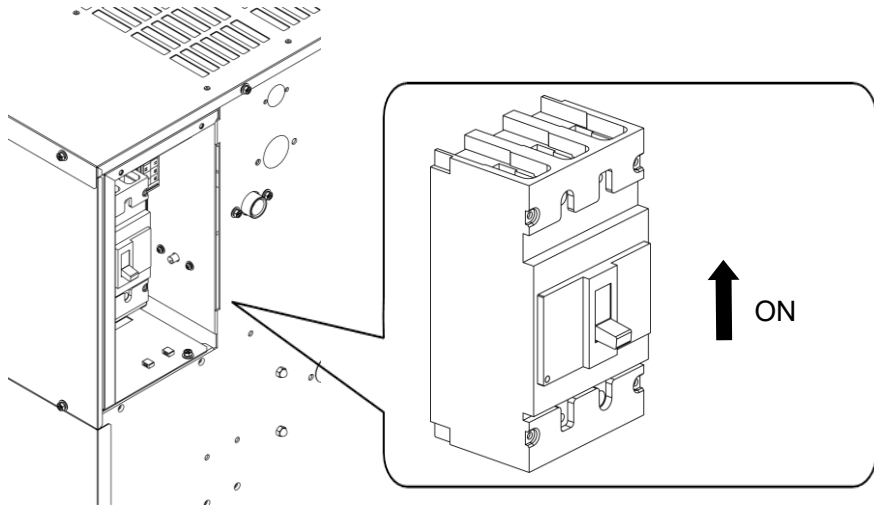

Fig. 3-18 Powered

**4.** Attach the power supply terminal cover using 4 screws.

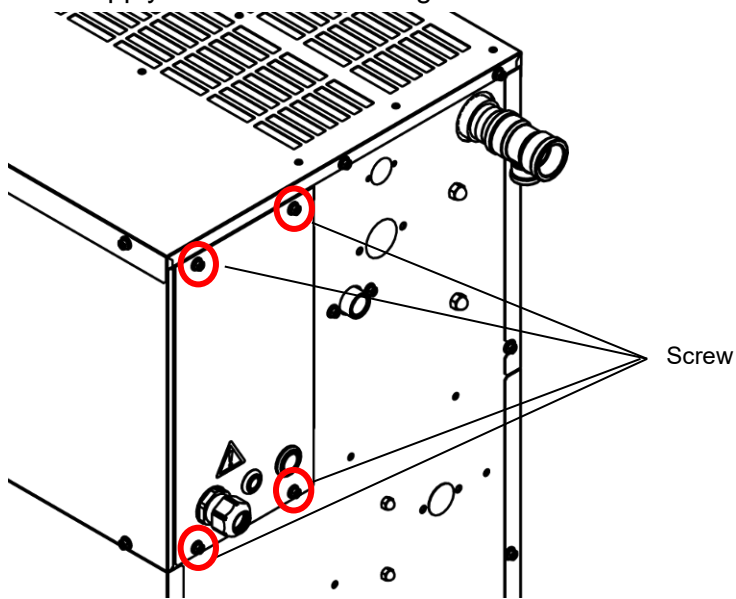

Fig. 3-19 Mounting of power supply terminal cover

## 3.4 Piping

### CAUTION



- Connect piping firmly. Incorrect piping might cause leakage of supplied or drained fluid getting the area wet, causing malfunction of the product or other facilities.
- Use caution to not allow dust and foreign matter to enter the water circuit, etc. during piping work.
- During piping work, residual liquid may drip from the circulating fluid circuit. Prepare a basin close to the piping connection to catch the residual liquid.
- Securely connect the piping at the piping port with a pipe wrench when tightening.
- The piping should be selected with due consideration of pressure and temperature.
- Incorrect piping can burst while in service.
- Use non-corrosive materials for parts that come in contact with circulating fluid. Using materials, such as aluminum or iron, that tend to rust or corrode for parts that come in contact with fluid may not only cause clogs in the circulating fluid circuits and leakage of the circulating fluid, but also leakage of refrigerant (CFC), causing unexpected problems. When using these kinds of materials, the customer needs to implement some preventive measures against rust and corrosion.
- Do not generate a rapid change in pressure with a water hammer, etc. Internal parts of the chiller and/or the piping may be damaged.
- Facility water temperature of the facility water outlet port might rise up to approx.60deg.C.

### ■ Port size

Table 3-7 Piping port size

Name	Port size	Recommended tightening torque	Recommended piping specifications
Circulating fluid outlet/ return port (CH1) *1	Rc1	36 to 38 N·m	1.0 MPa or more
Circulating fluid outlet/ return port (CH1) *2	Rc1/2	28 to 30 N·m	1.0 MPa or more
Circulating fluid outlet/ return port (CH2)	Rc1/2	28 to 30 N·m	1.0 MPa or more
Drain port	Rc1/4	8 to 12 N·m	-
Facility water inlet *3	Rc1/2	28 to 30N·m	1.0MPa or more. (Supply puressure : 0.3 to 0.5MPa)
Facility water outlet *3	Rc1/2	28 to 30N·m	
Automatic water-fill port *4	Rc3/8	22 to 24N·m	1.0MPa or more (Automatic water-fill pressure 0.2 to 0.5MPa)
Overflow port *4	Rc3/4	28 to 30N·m	of piping 19mm or more

\*1 : HRLE090 only.

\*2 : HRLE050 only.

\*3 : Water-cooled refrigeration only.

\*4 : For HRL-JK001 [Automatic fluid filling]

■ **How to connect piping**

When connecting drain piping, fix the ball valve with a wrench.

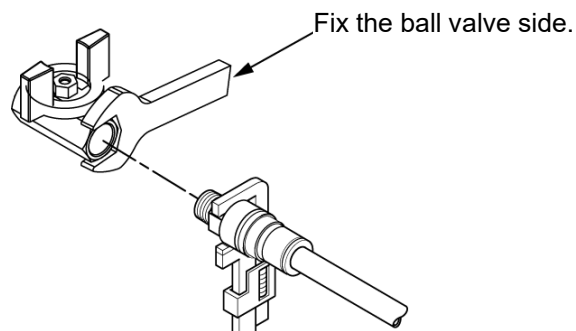

Fig. 3-20 Piping connection (Example)

**CAUTION**



**If you don't hold the ball valve of the drain port with a wrench, the ball valve may rotate, causing a fluid leak or malfunction of the product. Be sure to hold the ball valve of the drain port.**



## 3.5 Circulating Fluid Supply

Turn the tank lid counterclockwise to open. Supply the circulating fluid up to the "H" mark on the fluid level indicator. Use tap water or a 15% aqueous solution of ethylene glycol. About the water quality SMC recommends, please refer to "8.1 Water Quality Management".

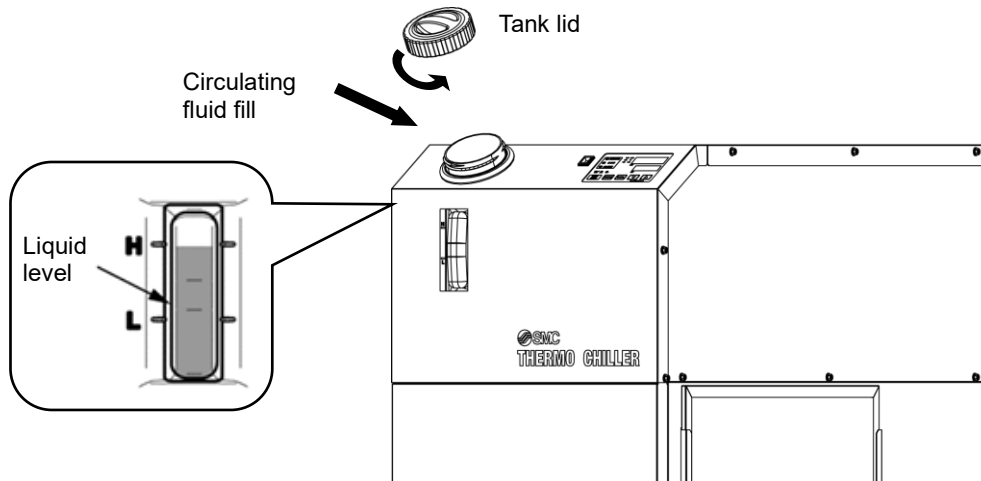

Fig. 3-21 Adding circulating fluid

### CAUTION



- When clear water is used, refer to "8.1 Water Quality Management".
- When deionized water is used, the conductivity should be  $0.4 \mu\text{S}/\text{cm}$  or higher (Electrical resistivity:  $2.5 \text{ M}\Omega \cdot \text{cm}$  or lower).
- Check that the drain port is closed with the valve to prevent the supplied circulating fluid from draining out.
- Supply recirculating fluid up to the "H" mark of the tank. Operation will stop when the fluid level falls lower than "L".



## Chapter 4 Starting the Product

### CAUTION



Only people who have sufficient knowledge and experience with the product and its accessories are allowed to start and stop the product.

### 4.1 Before Starting

Check the following points before starting the product.

#### ■ Installation state

- Check that the product is installed horizontally.
- Check that there are no heavy objects on the product, and the external piping is not applying excessive force to the product.

#### ■ Connection of cables

- Check that the power, ground, and communication signal cables (to be supplied by the user) are correctly connected.

#### ■ Circulating fluid piping

- Check that the circulating fluid piping is correctly connected to the inlet and outlet.

#### ■ Fluid level gauge

- Confirm that the fluid level is between the "H" and "L" levels of the fluid level gauge.

#### ■ Facility water piping (For Water-cooled refrigeration)

- Check proper connection of piping at the facility water inlet and outlet.
- Check that the facility water source is in operation.
- Check that the facility water circuit is not shut off by valves.

### CAUTION



- Supply facility water within the specified "8.1 Water Quality Management" and "9.1 Specifications".

#### [Tips]

In case of Water-cooled refrigeration, it has water regulation valve in facility water circuit. Facility water might not flow if this product stopping.

## 4.2 Preparation for Start

### 4.2.1 Power supply

1. Turn ON the breaker of the user's power supply.  
(Make sure that the breaker on the back of the product is turned on.)

2. Turn on the power supply switch on the front surface.

When the product is switched ON correctly, the operation panel display operates as shown below:

- The initial screen (HELLO screen) is displayed on the operation display panel. Then, the display changes to the main screen which shows the circulating fluid outlet temperature.  
\* When an alarm is generated, the alarm screen appears.
- The current circulating fluid temperature is displayed as PV on the digital display.
- The set circulating fluid temperature is displayed as SV on the digital display.

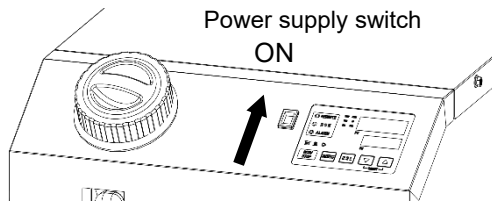

Fig. 4-1 Power supply

### 4.2.2 Setting of circulating fluid temperature

Press the [▼] or [▲] key on the operation panel to change the SV to the required value.

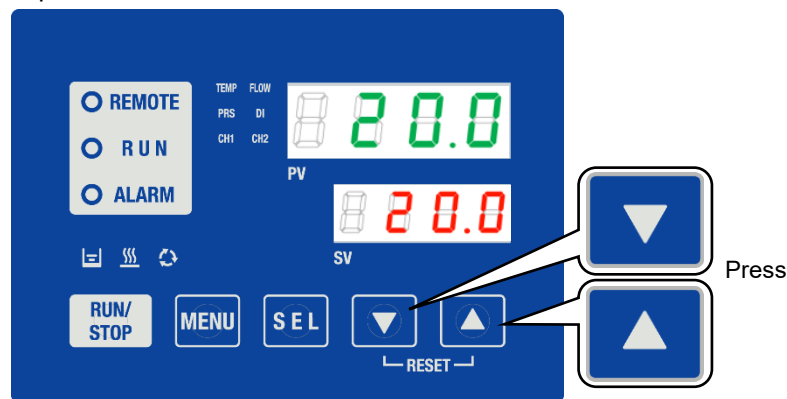



Fig. 4-2 Setting the circulating fluid temperature

## 4.3 Operation Start and Stop

### 4.3.1 Starting the Product

**⚠ CAUTION**

 • Allow at least 5 minutes before restarting the product.

Before starting, check the items specified in "4.1 Before Starting".

If any of the alarm lights remain ON, refer to "Chapter 7 Alarm Notification and Troubleshooting" and reset the alarm.

Press the [RUN/STOP] key on the operation panel.

The [RUN] light (green) turns ON and the product starts running.

The circulating fluid discharge temperature (PV) is controlled at the set temperature (SV)

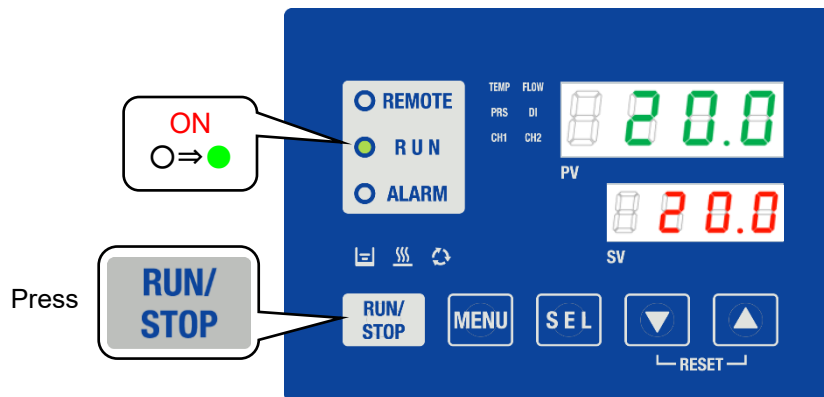

Fig. 4-3 Starting the product

**CAUTION**

If an alarm is generated, refer to "7.3 Troubleshooting".

### 4.3.2 Stopping the product

1. Press the [RUN/STOP] key on the operation panel.

The [RUN] light on the operation panel blinks green, and continues operation to prepare to stop. After approximately 20 seconds, the [RUN] light turns OFF and the operation stops completely.

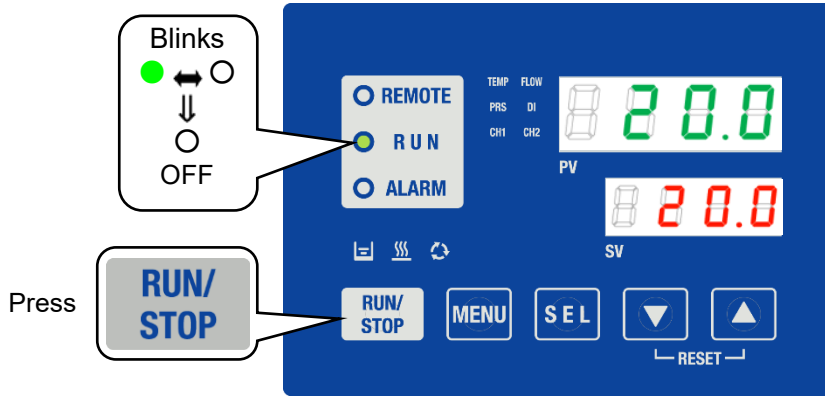

Fig. 4-4 Starting the product

2. Turn off the power supply switch. Turn OFF the user's power supply (power supply breaker) as needed.

#### CAUTION



Do not turn OFF the breaker before the Thermo-chiller stops operation completely except in an emergency. It may damage the product

### 4.4 Check Items during Startup

Check the following items after starting the product.

#### WARNING



When an abnormality is found, press the [STOP] key to stop the product, and then turn OFF the power supply switch and the breaker of the user's power supply.

- Confirm that there is leakage from the piping.
- Confirm that no circulating fluid is discharged from the drain port.
- Confirm that the circulating fluid pressure is within the specification range.
- Confirm that the fluid level shown by the fluid level gauge is within the specification range.

## 4.5 Adjustment of Circulating Fluid Flow Rate

When the circulating fluid flow rate is smaller than the minimum required, the product may be unable to maintain its performance, making it impossible for the compressor to operate. Refer to "Fig. 3-20 Piping connection (Example)", and adjust the flow rate with the manual valve to the required pressure or flow rate while monitoring the pressure or flow rate.

Ball Valve Set : HRL-BB001(for HRLE090), HRL-BB002(for HRLE050), is available. Please order separately.

### **[Note]**

Regarding the minimum required flow rate, refer to "9.1 Specifications".

When below the minimum flow rate, Bypass Piping Set : HRL-BP001,HRL-BP002 is available. Please order separately.

### **CAUTION**



**If the valve is located in the circulating fluid line, do not fully close the valve (flow rate: 0 L/min). The pump may get damaged.**





# Chapter 5 Display and Setting of Various Functions

## ⚠ WARNING



Carefully read and understand this manual before changing the settings.

## 5.1 List of Functions

The product can have the displays and settings shown in "Table 5-1 List of Functions".

Table 5-1 List of Functions

No.	Function	Outline	Reference page
1	Main menu	Displays the current temperature and set temperature of the circulating fluid, discharge pressure of the circulating fluid, and Electric conductivity of the circulating fluid. It also allows the circulating fluid temperature to be changed.	Chapter 5.3
2	Alarm menu	Displays the alarm number when an alarm is generated. Displays the current alarm only.	Chapter 5.4
3	Monitor menu	As part of the daily check, temperature, pressure, Electric conductivity, and accumulated operating time can be checked. Use this menu for your daily check.	Chapter 5.5
4	Setting menu	Key-lock, key operation sound, upper limit of fan output control, with or without Electric conductivity control function <sup>*1</sup> , TEMP READY signal, anti-freezing operation, etc. can be set. Various settings and the accumulated operating time of the dust-proof filter can be reset.	Chapter 5.6
5	Alarm setting menu	Depending on the alarm type, FLT (operation stops) and WRN (operation continues) can be switched and alarm settings can be changed.	Chapter 5.7
6	Communication setting menu	Enables/disables contact input / output.	Chapter 5.8
7	Electric conductivity control menu <sup>*1</sup>	This function controls the electrical conductivity of the circulating fluid flowing through the DI filter by a solenoid valve by setting the set value of the circulating fluid electrical conductivity and the hysteresis.	Chapter 5.9

\*1: Displayed only when the Electric conductivity control function is enabled. Please use the optional accessory HRL-DI001, DI002.

# 5.2 Function

## 5.2.1 Key operations

Fig. 5-1 Key operations (1/2) and Fig. 5-2 Key operations (2/2) show the key operations of the product.

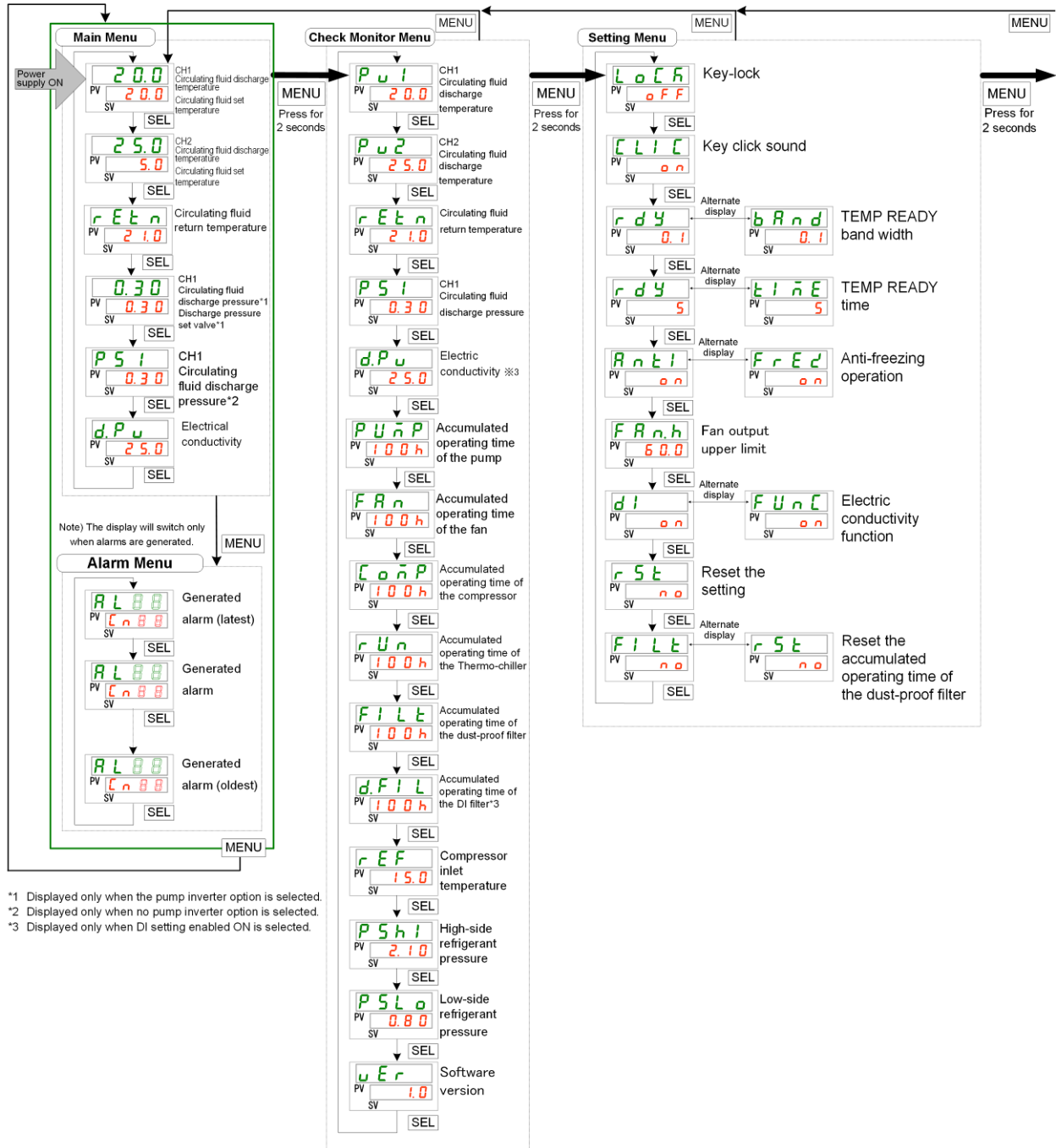
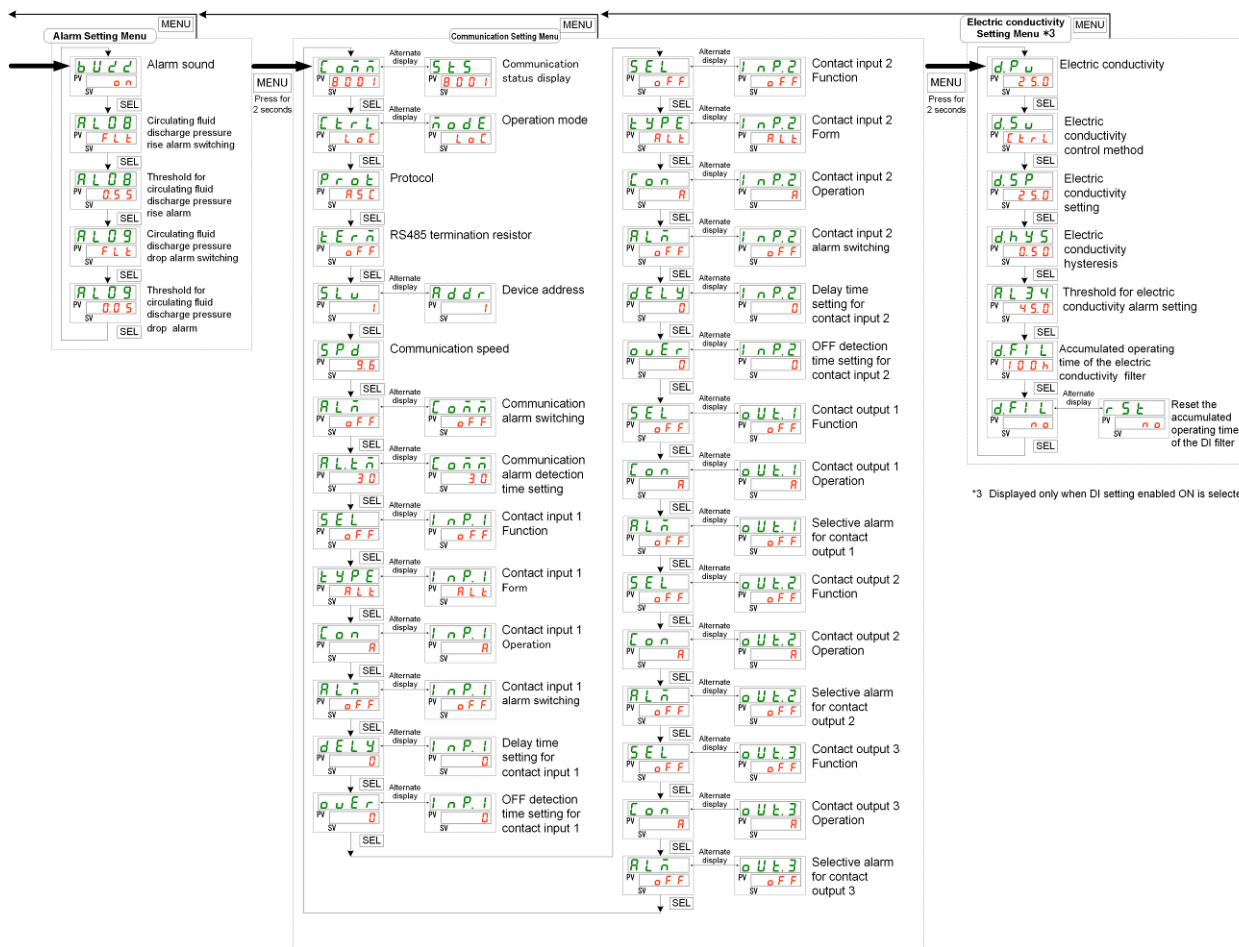

Fig. 5-1 Key operations (1/2)



\*3 Displayed only when DI setting enabled ON is selected.

Fig. 5-2 Key operations (2/2)

## 5.2.2 List of display and setting

The product can have the display and settings shown in Table 5-2 List of display and setting.

Table 5-2 List of display and setting

Display	Item	Setting range	Initial value	Unit	Category	Reference page		
CH1 temperature	CH1 circulating fluid temperature			°C	Main menu	Chapter 5.3		
	CH1 circulating fluid set temperature	15.0 to 25.0	20.0	°C				
CH2 temperature	CH2 circulating fluid temperature			°C				
	CH2 circulating fluid set temperature	0.0 to 15.0	5.0	°C				
r E t n	Circulating fluid return temperature			°C				
P S I	CH1 circulating fluid discharge pressure*1			MPa				
0.30	CH1 circulating fluid set discharge pressure	0.1 to 0.5	0.3	MPa				
d.P u	Electric conductivity*3			µS/cm				
AL 88	Alarm No.						Alarm display	Chapter 5.4
P u 1	CH1 circulating fluid discharge port temperature			°C			Monitor menu	Chapter 5.5
P u 2	CH2 circulating fluid discharge port temperature			°C				
r E t n	Circulating fluid return temperature			°C				
P S I	CH1 circulating fluid discharge pressure			MPa				
d.P u	Electric conductivity*3			µS/cm				
P U n P	Accumulated operating time of the pump			Hour				
F R n	Accumulated operating time of the fan*4			Hour				
C o n P	Accumulated operating time of the compressor			Hour				
r U n	Accumulated operating time of the Thermo-chiller			Hour				
F I L t	Accumulated operating time of the dust-proof filter*4			Hour				
d.F I L	Accumulated operating time of the DI filter*3			Hour				
r E F	Compressor inlet temperature			°C				
P S h i	High-side refrigerant pressure			MPa				
P S L o	Low-side refrigerant pressure			MPa				
u E r	Software version							
L o c k	Key-lock	OFF/ON	OFF		Setting menu	Chapter 5.6		
E L I C	Key operation sound	OFF/ON	ON					
r d y ⇨ b R n d	TEMP READY bandwidth	0.1 to 10.0	1.0	°C				
r d y ⇨ t i n E	TEMP READY time	0 to 60	5	s				
A n t i ⇨ F r E e d	Anti-freezing operation	OFF/ON	OFF					
F R n h	Fan output upper limit*4	40.0 to 100.0	60	%				
d i ⇨ F U n C	Electric conductivity function	OFF/ON	OFF					
r S t	Reset the setting	YES/NO	NO					
F I L t ⇨ r S t	Reset the accumulated operating time of the dust-proof filter*4	YES/NO	NO					

Display	Item	Setting range	Initial value	Unit	Category	Reference page
<b>bU22</b>	Alarm sound	OFF/ON	ON	/	Alarm setting menu	Chapter 5.7
<b>AL08</b>	Discharge pressure rise alarm switching	FLT/WRN	FLT	/		
<b>AL08</b>	Threshold for discharge pressure rise alarm	0.05 to 0.56	0.55	MPa		
<b>AL09</b>	Discharge pressure drop alarm switching	FLT/WRN	FLT	/		
<b>AL09</b>	Threshold for discharge pressure drop alarm	0.05 to 0.56	0.05	MPa		
<b>Coññ</b> ⇨ <b>5t5</b>	Communication status display	/	/	/	Communication Setting Menu	Chapter 5.8
<b>CtrL</b> ⇨ <b>ñode</b>	Operation mode switching	LOC/DIO/SER	LOC	/		
<b>Prot</b>	Serial communication protocol switching	ASC/RTU	ASC	/		
<b>tErñ</b>	Serial communication termination resistor switching	OFF/ON	OFF	/		
<b>Addr</b>	Serial communication device address setting	1~32	1	s		
<b>SPd</b>	Serial communication switching the communication speed	9.6/19.2	19.2	kbps		
<b>ALñ</b> ⇨ <b>Coññ</b>	Serial communication alarm switching	OFF/WRN/FLT	OFF,	/		
<b>ALtñ</b> ⇨ <b>Coññ</b>	Serial communication alarm detection time setting	0~600	30	s		
<b>SEL</b> ⇨ <b>InP.1</b>	Switching the signal type of the contact input 1	OFF/RN.ST/ RUN/SW/	RN.ST	/		
<b>tYPE</b> ⇨ <b>InP.1</b>	Switching the signal form of the contact input 1	ALT/MT	ALT	/		
<b>Con</b> ⇨ <b>InP.1</b>	Contact type switching of contact input 1	A/B	A	/		
<b>ALñ</b> ⇨ <b>InP.1</b>	Alarm switching for contact input 1	OFF/WRN/FLT	OFF	/		
<b>dELY</b> ⇨ <b>InP.1</b>	Delay time setting for contact input 1	0~600	0	s		
<b>ouEr</b> ⇨ <b>InP.1</b>	OFF detection time setting for contact input 1	0~10	0	s		
<b>SEL</b> ⇨ <b>InP.2</b>	Switching the signal type of the contact input 2	OFF/ SW/ STOP/ECO	SW	/		
<b>tYPE</b> ⇨ <b>InP.2</b>	Switching the signal form of the contact input 2	ALT/MT	ALT	/		
<b>Con</b> ⇨ <b>InP.2</b>	Contact type switching of contact input 2	A/B	A	/		
<b>ALñ</b> ⇨ <b>InP.2</b>	Alarm switching for contact input 2	OFF/WRN/FLT	OFF	/		
<b>dELY</b> ⇨ <b>InP.2</b>	Delay time setting for contact input 2	0~600	0	s		
<b>ouEr</b> ⇨ <b>InP.2</b>	OFF detection time setting for contact input 2	0~10	0	s		
<b>SEL</b> ⇨ <b>ouEt.1</b>	Switching the signal type of contact output 1	OFF/RUN/ RMT/FLT/ WRN/ALM/ RDY/FREZ/ SW1/SW2/ A.SEL	RUN	/		
<b>Con</b> ⇨ <b>ouEt.1</b>	Contact type switching of contact output 1	A/B	A	/		
<b>ALñ</b> ⇨ <b>ouEt.1</b>	Selective alarm setting for contact output 1	1~66	1	/		

Display	Item	Setting range	Initial value	Unit	Category	Reference page
SEL → OUT.2	Switching the signal type of contact output 2	OFF/RUN/ RMT/FLT/ WRN/ALM/ RDY/FREZ/ SW1/SW2/ A.SEL	ALM		Communication Setting Menu	Chapter 5.8
Con → OUT.2	Contact type switching of contact output 2	A/B	B			
ALn → OUT.2	Selective alarm setting for contact output 2	1~66	1			
SEL → OUT.3	Switching the signal type of contact output 3	OFF/RUN/ RMT/FLT/ WRN/ALM/ RDY/FREZ/ SW1/SW2/ A.SEL	RDY			
Con → OUT.3	Contact type switching of contact output 3	A/B	A			
ALn → OUT.3	Selective alarm setting for contact output 3	1~66	1			
d.5u	Electric conductivity Control method	CTRL / CLSE / OPEN	CTRL		DI Setting menu <sup>*3</sup>	Chapter5.9
d.5P	Electric conductivity set value	0.5 to 45.0	25.0	μS/cm		
d.h95	Electric conductivity hysteresis	0.1 to 10.0	0.5	μS/cm		
AL34	Threshold for Electric conductivity rise alarm	0.4 to 46.0	45.0	μS/cm		
d.FILL → r.5t	Reset the accumulated operating time of the DI filter	YES/NO	NO			

\*1: Not displayed when Option P is set.

\*2: Displayed only when Option P is set.

\*3: Displayed only when the Electric conductivity control function is enabled.

\*4: Displayed only when the Water-cooled refrigeration.





## 5.3 Main Menu

### 5.3.1 Main menu

Displays the current temperature and the set temperature of the circulating fluid. The main display allows the set temperature to be changed.

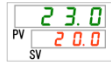
The table below explains the items displayed on the main menu. In the menu, you can go to the next item by pressing the [SEL] key.

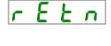
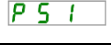
Table 5-3 Main menu items

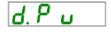
Item	Unit	Lit light	Display	Description
CH1 circulating fluid discharge temperature	°C	TEMP CH1		(Upper space) Displays the current temperature at the CH1 circulating fluid discharge port. (Lower space) Displays the CH1 circulating fluid set temperature. (Setting range: 15.0 to 25.0°C)
CH2 circulating fluid discharge temperature	°C	TEMP CH2		(Upper space) Displays the current temperature at the CH2 circulating fluid discharge port. (Lower space) Displays the CH2 circulating fluid set temperature. (Setting range: 0.0 to 15.0°C) * Set the CH2 temperature by specifying how much higher it should be than CH1 (in °C).
Circulating fluid return temperature	°C	TEMP		Displays the temperature of the circulating fluid returning to this product. It is the temperature after CH1 and CH2 have merged.
CH1 circulating fluid discharge pressure*1	MPa	PRS CH1		Displays the pressure at the CH1 circulating fluid discharge port.
Circulating fluid set discharge pressure*2	MPa	PRS CH1		(Upper space) Displays the current pressure at the CH1 circulating fluid discharge port. (Lower space) Displays the CH1 circulating fluid set discharge pressure. (Setting range: 0.10 to 0.50MPa)
Electric conductivity*3	μS/cm	DI		Displays the Electric conductivity of the circulating fluid in the tank of this product.

\*1: Not displayed when Option P is set.

\*2: Displayed only when Option P is set.

\*3: Displayed only when the Electric conductivity control function is enabled. Please use the optional accessory HRL-DI001,DI002.

### 5.3.2 Setting the circulating fluid discharge temperature

1. Press the [SEL] key to display the CH1 circulating fluid discharge temperature on the digital display.

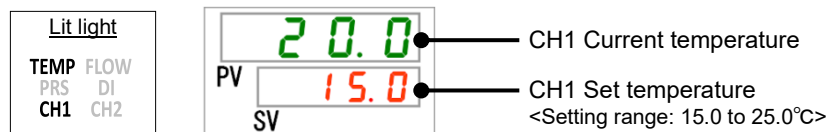

2. Change the set temperature with the [▼] or [▲] button.

After changing the value, set it by pressing the [SEL] button.

\* The setting blinks while it is being changed.

\* If the [SEL] button is not pressed, the value is set to the changed value after 3 seconds.

3. Press the [SEL] key to display the CH2 circulating fluid discharge temperature on the digital display.

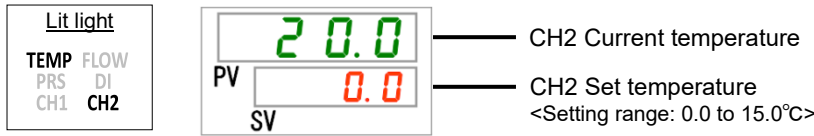

The setting of CH2 cannot be lower than that of CH1. That is why the CH2 set temperature must be set by specifying how much higher it should be than CH1 (in °C).  
(Example: When the CH1 set temperature is 20.0°C and the CH2 set temperature is 5.0°C, CH2 is controlled at 25.0°C.)

---

4. Change the set temperature with the [▼] or [▲] button.  
After changing the value, set it by pressing the [SEL] button.  
\* The setting blinks while it is being changed.  
\* If the [SEL] button is not pressed, the value is set to the changed value after 3 seconds.

### 5.3.3 Setting the CH1 circulating fluid discharge pressure (When selecting Option P)

1. Press the [SEL] key to display the CH1 circulating fluid discharge pressure on the digital display.

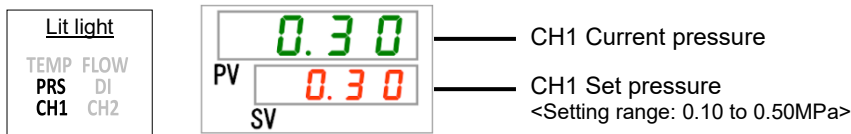

2. Change the set pressure with the [▼] or [▲] button.  
After changing the value, set it by pressing the [SEL] button.  
\* The setting blinks while it is being changed.  
\* If the [SEL] button is not pressed, the value is set to the changed value after 3 seconds.



## 5.4 Alarm Menu

### 5.4.1 Alarm menu

The alarm menu appears when an alarm has been generated.

\* The alarm menu is not accessible when no alarm has been generated.

\* Refer to "Chapter 7 Alarm Notification and Troubleshooting" for details of the alarms.

### 5.4.2 Items shown on the alarm menu

The alarm menu appears when an alarm has been generated. When multiple alarms have been generated, the latest alarm is shown on the display.

Each time the [SEL] button is pressed, the alarms are displayed in order, starting from the latest one.

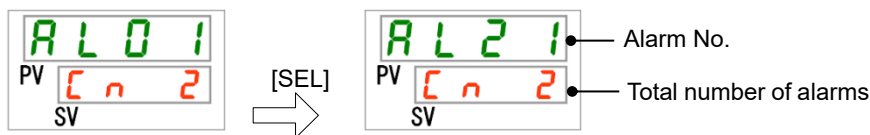

The main display is shown when the alarm is reset.



The main display is shown when the [MENU] button is pressed after an alarm has been generated.



The alarm menu is shown when the [MENU] button is pressed again.

## 5.5 Monitor Menu

### 5.5.1 Monitor menu

As part of the daily check, temperature, pressure, Electric conductivity, and accumulated operating time can be checked. Use this menu for your daily check.

When the "MENU" key is pressed and held (2 seconds) while the Main Menu screen is displayed, the display is changed to the "Monitor Menu".

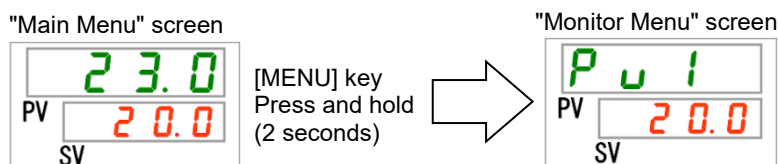

The table below explains the items in the monitor menu. In the menu, you can go to the next item by pressing the [SEL] key.

Press the [MENU] key once to return to the Main Menu.

Table 5-4 Monitor menu items

Item	Unit	Lit light	Display	Description
CH1 circulating fluid discharge port temperature	°C	TEMP, CH1	P u 1	Displays the temperature at the CH1 circulating fluid discharge port.
CH2 circulating fluid discharge port temperature	°C	TEMP, CH2	P u 2	Displays the temperature at the CH2 circulating fluid discharge port.
Circulating fluid return temperature	°C	TEMP	r E t n	Displays the temperature of the circulating fluid returning to this product. It is the temperature after CH1 and CH2 have merged.
CH1 circulating fluid discharge pressure	MPa	PRS, CH1	P S 1	Displays the pressure at the CH1 circulating fluid discharge port.
Electric conductivity *1	µS/cm	DI	d.P u	Displays the Electric conductivity of the circulating fluid in the tank.
Accumulated operating time of the pump	Hour		P U n P	Displays the accumulated operating time of the pump.
Accumulated operating time of the fan *2	Hour		F A n	Displays the accumulated operating time of the fan motor.
Accumulated operating time of the compressor	Hour		C o m P	Displays the accumulated operating time of the compressor.
Accumulated operating time of the Thermo-chiller	Hour		r U n	Displays the accumulated operating time of the Thermo-chiller.
Accumulated operating time of the dust-proof filter *2	Hour		F I L T	Displays the accumulated operating time of the dust-proof filter.
Accumulated operating time of the DI filter *1	Hour		d.F I L	Displays the accumulated operating time of the DI filter.
Compressor inlet temperature	°C	TEMP	r E F	Displays the refrigerant temperature at the compressor inlet port.
High-side refrigerant pressure	MPa	PRS	P S h I	Displays the pressure on the higher pressure side of the refrigerant circuit.
Low-side refrigerant pressure	MPa	PRS	P S L o	Displays the pressure on the lower pressure side of the refrigerant circuit.
Software version	-		u E r	Display the version of the software of this product.

\*1: Displayed only when the Electric conductivity control function is enabled.

\*2: Not displayed when Water-cooled refrigeration is selected.

Table 5-5 Time display

Accumulated time	Displayed value
0 h to 999 h	0 h to 999 h
1,000 h to 999,999 h	-----1 ⇨ 000 h to 999 ⇨ 999 h

## 5.6 Setting Menu

### 5.6.1 Setting menu

Items other than temperatures and alarms can be set.

When the "MENU" key is pressed and held (2 seconds) while the Monitor Menu screen is displayed, the display is changed to the "Setting Menu".

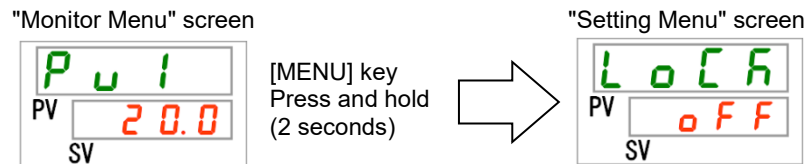

The table below explains the items in the setting menu. In the menu, you can go to the next item by pressing the [SEL] key.

Press the [MENU] key once to return to the Main Menu.

Table 5-6 Setting menu items

Item	Lit light	Display	Reference page
Key-lock setting	/	L o C k	Chapter 5.6.2
Button click sound setting	/	C L I C	Chapter 5.6.3
TEMP READY signal band width	TEMP, CH1	r d y ⇨ b A n d	Chapter 5.6.4
Time setting for TEMP READY signal for out of range	CH1	r d y ⇨ t i m e	Chapter 5.6.5
Anti-freezing function setting	/	A n t i ⇨ F r e e z	Chapter 5.6.6
Fan output upper limit*1	/	F A n . h	Chapter 5.6.7
Electric conductivity function setting	/	d l ⇨ F U n C	Chapter 5.6.8
Reset the setting	/	r S e t	Chapter 5.6.9
Reset of the accumulated operating time of the dust-proof filter*1	/	F I L T ⇨ r S e t	Chapter 5.6.10

\*1: Not displayed when Water-cooled refrigeration is selected.

### 5.6.2 Key-lock setting

A function to prevent settings from being changed by mistake. Operation can be started/stopped by operating the [RUN/STOP] key even when the key-lock has been enabled.

The initial value is "OFF: Key-lock disabled".

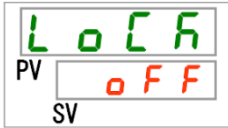

— OFF: Key-lock disabled / ON: Key-lock enabled  
 Make a selection with the [▲] [▼] keys and press the [SEL] key to apply the setting.

If you try to change a setting with the "▲" or "▼" key while the button-lock function is enabled, "LoCk" will be displayed for 1 second, and you cannot change the setting.

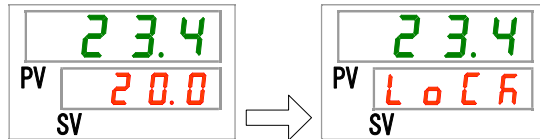

### 5.6.3 Key click sound setting

The operation sound of the keys when the keys are used can be turned ON and OFF.

The initial value is "ON: Key operation sound enabled".



— OFF: Key operation sound disabled / ON: Key operation sound enabled  
 Make a selection with the [▲] [▼] keys and press the [SEL] key to apply the setting.

### 5.6.4 Band width setting for the TEMP READY signal

This function sets a TEMP READY signal band width for the circulating fluid temperature (range between the upper and lower limit temperatures) to notify the user via contact output and serial communication that the circulating fluid temperature has reached the signal band width in the temperature range set by the user.

You can set this value in the range of ± "0.1 to 10.0°C". Setting this to 1.0°C means a temperature range of ±1.0°C.

The initial value is "1.0" (±1.0°C).

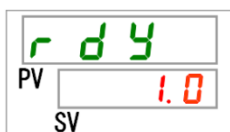

— RDY and BAND are displayed alternately.  
 — Change the set temperature with the [▼] or [▲] button. After changing the value, set it by pressing the [SEL] button.  
 \* The setting blinks while it is being changed.  
 \* If the [SEL] button is not pressed, the value is set to the changed value after 3 seconds.

## 5.6.5 Setting of time for TEMP READY signal for out of range

You can set how many seconds after the circulating fluid temperature has gone out of the set TEMP READY signal band width (range between the upper and lower limit temperatures), the TEMP READY signal is turned OFF.

You can set this value in the range of "0 to 60 seconds". If you set this to 10 seconds, the TEMP READY signal is turned OFF 10 seconds after the circulating fluid temperature has gone out of the set TEMP READY signal range.

The initial value is "5 seconds".

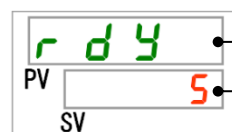

RDY and TEMP are displayed alternately.

Change the set temperature with the [▼] or [▲] button. After changing the value, set it by pressing the [SEL] key.

\* The setting blinks while it is being changed.

\* If the [SEL] button is not pressed, the value is set to the changed value after 3 seconds.

## 5.6.6 Anti-freezing function setting

This function prevents the circulating fluid from freezing while operation of the product is stopped in the winter season with heat generated by automatically operating the pump.

The default is "OFF: Anti-freezing operation disabled".



ANTI and FREZ are displayed alternately.

OFF: Anti-freezing function disable / ON: Anti-freezing function enabled. Make a selection with the [▲] [▼] keys and press the [SEL] key to apply the setting.

For the anti-freezing function, refer to "5.10 Anti-freezing function".

## 5.6.7 Fan output upper limit

The upper limit of the fan output can be changed in the range of "40.0 to 100%"

The initial value is "60.0%(HRLE090)", "100%(HRLE050)".



Change the value with the [▼] or [▲] button. After changing the value, set it by pressing the [SEL] key.

\* The setting blinks while it is being changed.

\* If the [SEL] button is not pressed, the value is set to the changed value after 3 seconds.

### 5.6.8 Electric conductivity function setting

Enables / Disables the function of Electric conductivity control.

Controls the value of the Electric conductivity when using the optional accessory HRL-DI001,DI002.

The initial value is "OFF: Electric conductivity function disabled".

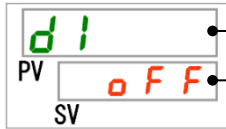

DI and FANC are displayed alternately.  
OFF: Electric conductivity control disabled / ON: Electric conductivity control enable  
Make a selection with the [▲] [▼] keys and press the [SEL] key to apply the setting.

### 5.6.9 Reset the setting

Resets the values set by the user to the default values.

Accumulated operating time of the Thermo-chiller, accumulated operating time of the dust-proof filter and accumulated operating time of the DI filter are not reset.



Select "YES" with the [▲] [▼] keys and press the [SEL] key to reset the set value. This then returns to NO automatically.

**CAUTION**



**Applies to all settings. Use caution when operating this function. It is recommended to record the setting data before resetting.**

### 5.6.10 Reset of the accumulated operating time of the dust-proof filter

Resets the accumulated operating time of the dust-proof filter.

When the operating time of the dust-proof filter is reset, the accumulated operating time becomes "0 hours".



FILT and RST are displayed alternately.  
Select "YES" with the [▲] [▼] keys and press the [SEL] key to reset the set value. This then returns to NO automatically.

## 5.7 Alarm Setting Menu

### 5.7.1 Alarm setting menu

For some alarms, operation when an alarm is generated and alarm thresholds can be changed.

When the "MENU" key is pressed and held (2 seconds) while the "Setting Menu" screen is displayed, the screen is changed to the "Alarm Setting Menu".

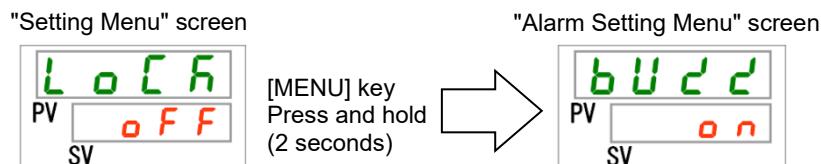

The table below explains the items in the alarm setting menu. In the menu, you can go to the next item by pressing the [SEL] key.

Press the [MENU] key once to return to the Main Menu.

Table 5-7 Alarm setting menu items

Item	Lit light	Display	Reference page
Alarm Sound Setting		bUcC	Chapter 5.7.2
Discharge pressure rise alarm switching		AL08	Chapter 5.7.3
Threshold for discharge pressure rise alarm setting	PRS	AL08	Chapter 5.7.4
Discharge pressure drop alarm switching		AL09	Chapter 5.7.5
Threshold for discharge pressure drop alarm setting	PRS	AL09	Chapter 5.7.6

### 5.7.2 Alarm sound setting

This sets whether a warning sound is made or not when an alarm is generated.

The initial value is "ON: Alarm sound enabled".

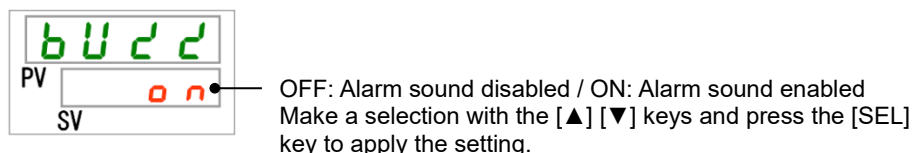

### 5.7.3 Discharge pressure rise alarm (AL08) switching

Switches operation of this product when a circulating fluid discharge pressure rise alarm is generated.

The default value is "FLT: Operation stop".

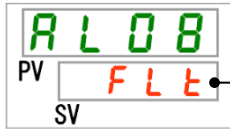

WRN: Continue operation / FLT: Stop operation  
Make a selection with the [▲] [▼] keys and press the [SEL] key to apply the setting.

### 5.7.4 Threshold for discharge pressure rise alarm (AL08) setting

The threshold of the circulating fluid discharge pressure rise alarm can be set in the range of "0.05 to 0.56 MPa".

The default value is "0.55 MPa".

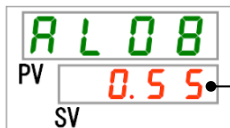

Change the set temperature with the [▼] or [▲] key.  
After changing the value, set it by pressing the [SEL] key.  
\* The setting blinks while it is being changed.  
\* If the [SEL] button is not pressed, the value is set to the changed value after 3 seconds.

### 5.7.5 Discharge pressure drop alarm (AL09) switching

Switches operation of this product when a circulating fluid discharge pressure drop alarm is generated.

The default value is "FLT: Operation stop".

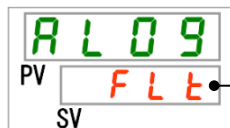

WRN: Continue operation / FLT: Stop operation  
Make a selection with the [▲] [▼] keys and press the [SEL] key to apply the setting.

### 5.7.6 Threshold for discharge pressure drop alarm (AL09) setting

The threshold of the circulating fluid discharge pressure drop alarm can be set in the range of "0.05 to 0.56 MPa".

The default value is "0.05 MPa".



Change the set temperature with the [▼] or [▲] key.  
After changing the value, set it by pressing the [SEL] key.  
\* The setting blinks while it is being changed.  
\* If the [SEL] button is not pressed, the value is set to the changed value after 3 seconds.



## 5.8 Communication Setting Menu

### 5.8.1 Communication setting menu

Communication functions can be set.

When the "MENU" key is pressed and held (2 seconds) while the "Alarm Setting Menu" screen is displayed, the screen is changed to the "Communication Setting Menu".

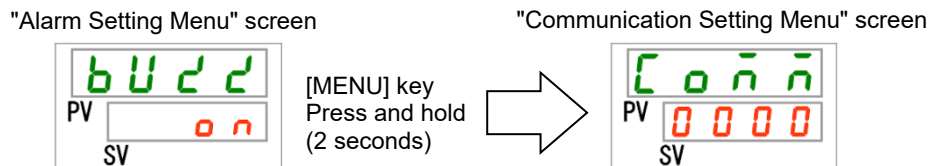

Press the [MENU] key once to return to the Main Menu.

Table 5-8 Communication setting menu items

Item	Lit light	Display	Reference page
Communication status display		Coññ ⇌ StS	Chapter 5.8.2
Operation mode switching		Ctrl ⇌ ñode	Chapter 5.8.3
Serial communication protocol switching		Prot	Chapter 5.8.4
Serial communication termination resistor switching		Terñ	Chapter 5.8.5
Serial communication device address setting		Addr	Chapter 5.8.6
Serial communication switching the communication speed		SPd	Chapter 5.8.7
Serial communication alarm switching		ALñ ⇌ Coññ	Chapter 5.8.8
Serial communication alarm detection time setting		AL.tñ ⇌ Coññ	Chapter 5.8.9
Switching the signal type of the contact input 1		SEL ⇌ InP.1	Chapter 5.8.10
Switching the signal form of the contact input		TYPE ⇌ InP.1	Chapter 5.8.11
Contact type switching of contact input 1		Con ⇌ InP.1	Chapter 5.8.12
External switching for contact input 1		ALñ ⇌ InP.1	Chapter 5.8.13
Delay time setting for contact input 1		dELY ⇌ InP.1	Chapter 5.8.14
OFF detection time setting for contact input 1		oUEr ⇌ InP.1	Chapter 5.8.15
Switching the signal type of the contact input 2		SEL ⇌ InP.2	Chapter 5.8.10
Switching the signal form of the contact input 2		TYPE ⇌ InP.2	Chapter 5.8.11
Contact type switching of contact input 2		Con ⇌ InP.2	Chapter 5.8.12
External switching for contact input 2		ALñ ⇌ InP.2	Chapter 5.8.13
Delay time setting for contact input 2		dELY ⇌ InP.2	Chapter 5.8.14

Item	Lit light	Display	Reference page
OFF detection time setting for contact input 2	/	o u E r ⇒ I n P . 2	Chapter 5.8.15
Switching the signal type of contact output 1	/	S E L ⇒ o U t . 1	Chapter 5.8.16
Contact type switching for contact output 2	/	C o n ⇒ o U t . 1	Chapter 5.8.17
Selective alarm setting for contact output 1	/	A L ā ⇒ o U t . 1	Chapter 5.8.18
Switching the signal type of contact output 2	/	S E L ⇒ o U t . 2	Chapter 5.8.16
Contact type switching for contact output 2	/	C o n ⇒ o U t . 2	Chapter 5.8.17
Selective alarm setting for contact output 2	/	A L ā ⇒ o U t . 2	Chapter 5.8.18
Switching the signal type of contact output 3	/	S E L ⇒ o U t . 3	Chapter 5.8.16
Contact type switching for contact output 3	/	C o n ⇒ o U t . 3	Chapter 5.8.17
Selective alarm setting for contact output 3	/	A L ā ⇒ o U t . 3	Chapter 5.8.18

### 5.8.2 Communication status display

It is a function to display the status of serial communication. Slave address mismatch or register map of this product display relevant contents for communication nonconformities, such as accessing outside the area.

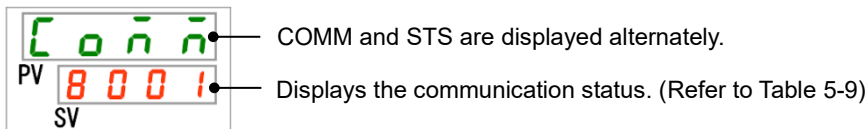

Table 5-9 Communication status

Communication setting	Contents
8001	Normal message
4801	An abnormal number of data has been sent from the customer device.
4401	This product is trying to access to the outside address of the register map that support.Or trying to write to read-only address.
4201	Function code that this product does not support is being sent from the customer's equipment.
0081	The slave addresses set for this product and customer's device are different.
0041	CRC does not match in the RTU settings.
0021	LRC does not match in the ASCII settings.
00XX	Mismatched communication settings(Baud Rate, parity, number of data bits, etc.)or very short message intervals from customer equipment.
0000	Bad wiring or no message sent from customer equipment.

### 5.8.3 Operation mode switching

Switches the operation mode.

The initial value is "LOC: LOCAL operation".



LOC: LOCAL operation / DIO: DIO operation / SER: SERIAL operation  
Make a selection with the [▲] [▼] keys and press the [SEL] key to apply the setting.

Table 5-10 Operation mode

Operation mode	Description	Contents	Display
LOCAL	Run / Stop and circulating fluid temperature setting are possible with the touch panel.	Set the operation mode to "LOCAL".	Displayed as "LOC"
DIO	Run / Stop by contact input. Circulating fluid temperature setting is done at the operation display panel.	Set the operation mode to "DIO".	Displayed as "DIO"
SERIAL	Run / Stop and circulating fluid temperature setting are possible with the serial communication(RS-485)	Set the operation mode to "SERIAL".	Displayed as "SER"

### 5.8.4 Serial communication protocol switching

Switches the protocol for serial communication.

The initial value is "ASC:ASCII mode".

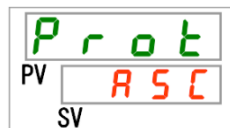

ASC:ASC II mode / RTU:RTU mode  
Make a selection with the [▲] [▼] keys and press the [SEL] key to apply the setting.

### 5.8.5 Serial communication termination resistance switching

Switches the terminal resistance for serial communication.

The initial value is "OFF: No terminal resistance".



OFF: No terminal / ON: With terminal  
Make a selection with the [▲] [▼] keys and press the [SEL] key to apply the setting.

### 5.8.6 Serial communication device address setting

The device address for serial communication can be set in the range of "1 to 32".

The initial value is "1".

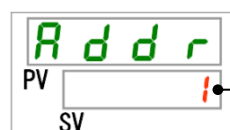

Change the set device address with the [▼] or [▲] key.  
After changing the value, set it by pressing the [SEL] key.  
\* The setting blinks while it is being changed.  
\* If the [SEL] button is not pressed, the value is set to the changed value after 3 seconds.

### 5.8.7 Serial communication switching the communication speed

Switches the communication speed for serial communication.

The initial value is "19.2: 19200bps".

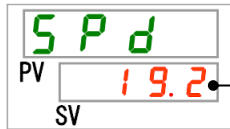

9.6: 9600bps / 19.2: 19200bps  
Make a selection with the [▲] [▼] keys and press the [SEL] key to apply the setting.

### 5.8.8 Serial communication alarm switching

This function is used to switch the Switch's operation when an alarm corresponding to AL19 occurs.

The initial value is "WRN: Continued operation".



OFF: Disable / WRN: Continued operation / FLT: Stop operation  
Make a selection with the [▲] [▼] keys and press the [SEL] key to apply the setting.

### 5.8.9 Serial communication alarm detection time setting

The time from the detection of a communication alarm until the alarm is generated can be set in the range of "0 to 600s".

The initial value is "30s".

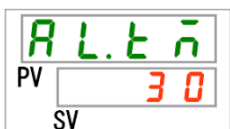

Change the set detection time with the [▼] or [▲] key.  
After changing the value, set it by pressing the [SEL] key.  
\* The setting blinks while it is being changed.  
\* If the [SEL] button is not pressed, the value is set to the changed value after 3 seconds.

### 5.8.10 Switching the signal type of the contact input

Switches the signal type of the contact input.

The initial value is " contact input 1: RN.ST, contact input 2: SW".



OFF: Disable / RN.ST: Run/Stop (Contact input 1 only)  
RUN: Operation (contact input 1 only) / SW: External switch signal  
STOP: Stop (contact input 2 only)  
ECO: Energy saving mode (contact input 2 only)  
Make a selection with the [▲] [▼] keys and press the [SEL] key to apply the setting.

### 5.8.11 Switching the signal form of the contact input

This function switches the signal form of the contact input.

The initial value is "ALT: Alternate".

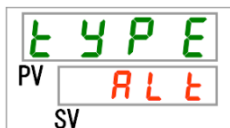

ALT: Alternate / MT: Momentary  
Make a selection with the [▲] [▼] keys and press the [SEL] key to apply the setting.

### 5.8.12 Contact type switching of contact input

Switches the contact type of the contact input.

The initial value is "A: Contact A (normally open)".



A: Contact A (normally open) / B: Contact B (normally closed)  
Make a selection with the [▲] [▼] keys and press the [SEL] key to apply the setting.

### 5.8.13 Alarm switching for contact input

Switches the operation of the Switch when an external switch signal is assigned to the contact input.

The initial value is "OFF: Disable".

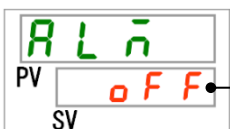

OFF: Disable / WRN: Continued operation / FLT: Stop operation  
Make a selection with the [▲] [▼] keys and press the [SEL] key to apply the setting.

### 5.8.14 Delay time setting for contact input

The external switch signal is read after the "delay" time has elapsed from the start of operation. The time can be set in the range of "0 to 300s".

The initial value is "0s".



Change the set delay time with the [▼] or [▲] key.  
After changing the value, set it by pressing the [SEL] key.  
\* The setting blinks while it is being changed.  
\* If the [SEL] button is not pressed, the value is set to the changed value after 3 seconds.

### 5.8.15 OFF detection time setting for contact input

After the external switch signal is turned on, the product receives the ON signal after the "OFF detection" time has elapsed. That time can be set in the range of "0 to 10s".

The initial value is "0s".



Change the set OFF detection time with the [▼] or [▲] key. After changing the value, set it by pressing the [SEL] key.

\* The setting blinks while it is being changed.

\* If the [SEL] button is not pressed, the value is set to the changed value after 3 seconds.

### 5.8.16 Switching the signal type of contact output

Switches the signal type of the contact input.

The initial value is "RUN: Operation status signal (output 1) / ALM: Alarm status signal (output 2) / RDY: TEMP READY status signal (output 3)".



Refer to Table 5-11.

Make a selection with the [▲] [▼] keys and press the [SEL] key to apply the setting.

Table 5-11 Signal types of contact outputs 1, 2, and 3

Indication	Type	Contact type	Description
OFF	Disable	A	Normally : open
		B	Normally : open
RUN	Operation status signal	A	Run : close
		B	Run : open
RMT	Remote operation	A	The time of remote operation : close
		B	The time of remote operation : open
FLT	Operation stop [FLT] alarm status signal	A	The time of alarm : close
		B	The time of alarm : open
WRN	Continued operation [WRN] alarm status signal	A	The time of alarm : close
		B	The time of alarm : open
ALM	[FLT+WRN] alarm status signal	A	The time of alarm : close
		B	The time of alarm : open
RDY	TEMP READY status signal	A	TEMP READY status : close
		B	TEMP READY status : open
FREZ	Anti-freezing setting status signal	A	Enabled : close
		B	Enabled : open
SW1	Pass through signal of the contact input 1	A	Outputs the input signal as it is.
		B	Invert the input signal and output.
SW2	Pass through signal of the contact input 2	A	Outputs the input signal as it is.
		B	Invert the input signal and output.
A.SEL	Selected alarm status signal	A	Selected alarm occurrence : close
		B	Selected alarm occurrence : open

### 5.8.17 Contact type switching of contact output

Switches the contact type of the contact output.

The initial value is " A: A contact (normally open)(output 1,3) / B: B contact (normally closed) (output 2)".



A: A Contact (normally open) / B: B Contact (normally closed)  
Make a selection with the [▲] [▼] keys and press the [SEL] key to apply the setting.

### 5.8.18 Selective alarm setting for contact output

When the selected alarm status signal is selected as the signal type for contact output, the alarm No. to be selected can be set in the range of "1 to 66".

The initial value is "1 : AL01".



Change the set OFF detection time with the [▼] or [▲] key.  
After changing the value, set it by pressing the [SEL] key.

\* The setting blinks while it is being changed.

\* If the [SEL] button is not pressed, the value is set to the changed value after 3 seconds.

## 5.9 Electric conductivity Control Function

This function controls the Electric conductivity by causing the circulating fluid to flow into the DI filter by using a solenoid valve based on the input of the Electric conductivity setting value and hysteresis. The measurement range and setting range are shown below.

Measurement range of Electric conductivity	0.1 to 48.0 $\mu\text{S}/\text{cm}$
Setting value range of Electric conductivity	0.5 to 45.0 $\mu\text{S}/\text{cm}$
Setting range of Electric conductivity hysteresis	0.1 to 10.0 $\mu\text{S}/\text{cm}$

\*Default values are: "Set Electric conductivity: 25.0  $\mu\text{S}/\text{cm}$ ", "Hysteresis: 0.5  $\mu\text{S}/\text{cm}$ ".

[Operation example of Electric conductivity control]

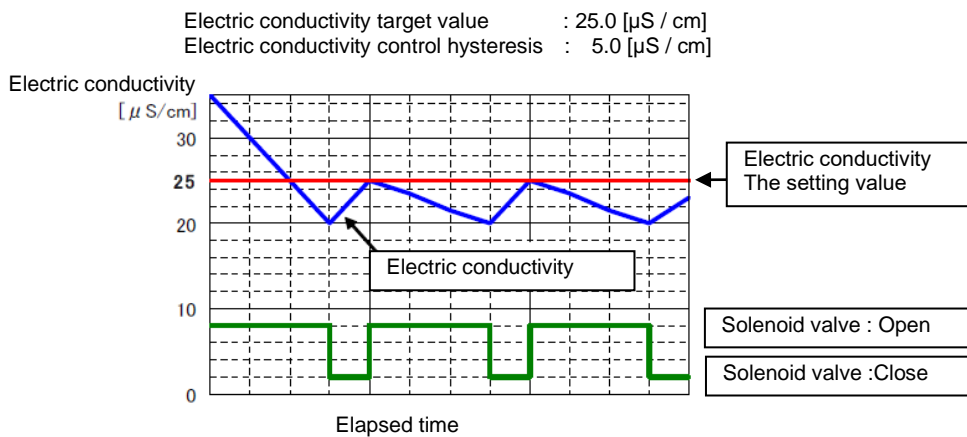

The solenoid valve for Electric conductivity control can be set to always open/always closed.

Item	Selected method	Solenoid valve operation
Electric conductivity control method	CTRL	Solenoid valve opens/closes to control Electric conductivity.
	OPEN	Solenoid valve is always open.
	CLSE	Solenoid valve is always closed.

\* Default is "CTRL".

Table 5-12 Electric conductivity setting menu items

Item	Lit light	Display	Reference page
Electric conductivity	/	d.P u	Chapter 5.9.1
Electric conductivity control method setting	DI	d.5 u	Chapter 5.9.2
Electric conductivity setting	DI	d.5 P	Chapter 5.9.3
Electric conductivity hysteresis setting	DI	d.h Y S	Chapter 5.9.4
Threshold for Electric conductivity rise alarm setting	/	AL 3 4	Chapter 5.9.5
Accumulated operating time of the DI filter	/	d.F I L	Chapter 5.9.6
Reset the accumulated operating time of the DI filter	/	d.F I L = r S t	Chapter 5.9.7



### 5.9.1 Electric conductivity

Display the electrical conductivity of the circulating fluid.

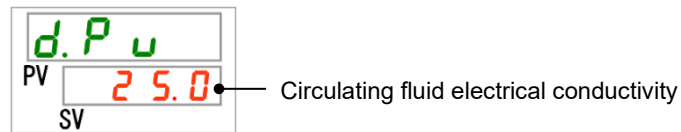

### 5.9.2 Electric conductivity control method setting

A solenoid valve can be used to flow the circulating liquid to the DI filter to control the Electric conductivity.

This solenoid valve can also be set to Normally OPEN / Normally CLOSE.

The initial value is "CTRL: Electric conductivity Control".

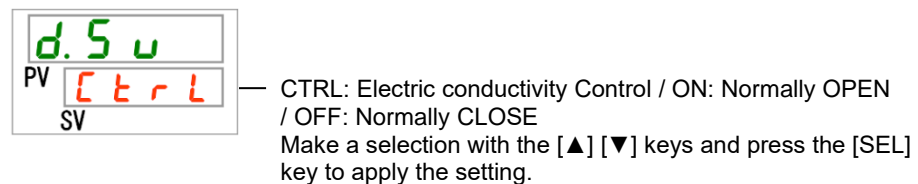

### 5.9.3 Electric conductivity setting

The setting value of the Electric conductivity can be set in the range of "0.5 to 45.0  $\mu\text{S}/\text{cm}$ ".

The initial value is "25.0  $\mu\text{S}/\text{cm}$ ".

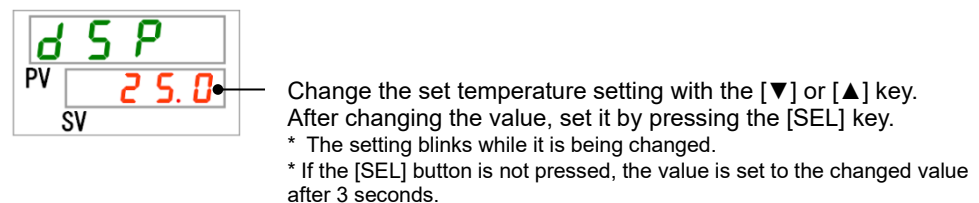

### 5.9.4 Electric conductivity hysteresis setting

Electric conductivity control hysteresis can be set in the range of "0.1 to 10.0  $\mu\text{S}/\text{cm}$ ".

The initial value is "0.5  $\mu\text{S}/\text{cm}$ ".

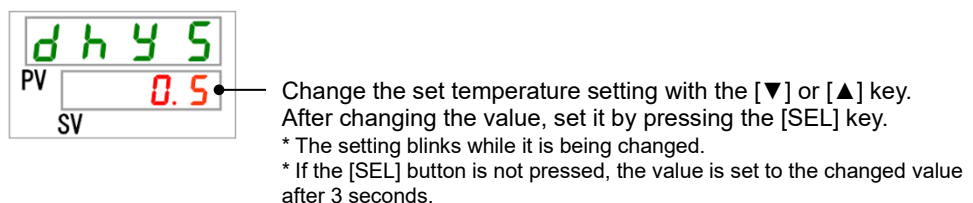

For an image of the Electric conductivity control by hysteresis, please refer to "5.9 Electric conductivity Control Function".

### 5.9.5 Threshold for Electric conductivity rise alarm (AL34) setting

The threshold of the circulating fluid Electric conductivity rise alarm can be set in the range of 0.4 to 46.0  $\mu\text{S}/\text{cm}$ .

The initial value is 45.0  $\mu\text{S}/\text{cm}$

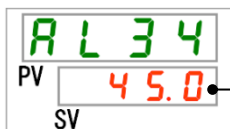

Change the set temperature with the [▼] or [▲] key.  
 After changing the value, set it by pressing the [SEL] key.  
 \* The setting blinks while it is being changed.  
 \* If the [SEL] button is not pressed, the value is set to the changed value after 3 seconds.

### 5.9.6 Accumulated operating time of the DI filter

Accumulated operating time of the DI filter.

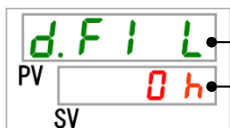

D.FIL and RST are displayed alternately.  
 Refer to Table 5-5

### 5.9.7 Reset of the accumulated operating time of the DI filter

Resets the accumulated operating time of the DI filter.

When the operating time of the DI filter is reset, the accumulated operating time becomes "0 hours".



D.FIL and RST are displayed alternately.  
 Select "YES" with the [▲] [▼] keys and press the [SEL] key to reset the set value. This then returns to NO automatically.

## 5.10 Anti-freezing Function

### CAUTION



**Keep the power supply ON for this function. This function does not operate when the power is OFF.**

This function prevents the circulating fluid from freezing while operation of the product is stopped in the winter season with heat generated by automatically operating the pump. When there is a possibility of the circulating fluid freezing due to changes in the installation or operating environment (e.g., season, weather), set this function ON in advance.

- When the circulating fluid temperature falls down to 3°C or less, the pump starts operation automatically.
- Heat generated by the pump operation warms up the circulating fluid.  
When the circulating fluid temperature reaches 5°C or higher, the pump stops operation automatically.
- Repeated automatic start/stop operation of the pump maintains the circulating fluid temperature within the range of 3°C to 5°C to prevent the circulating fluid from freezing.

The  lamp turns on when the anti-freezing function is enabled. The [RUN] lamp turns on during automatic operation of the pump. This function is set to OFF when the product is shipped from the factory.

### CAUTION



- **This function can be activated only when the power supply is ON and the Thermo-chiller is not operating.**
- **Fully open the valve or manual by-pass valve that is arranged by the user to allow the circulating fluid to circulate when the pump starts automatic operation.**
- **In extremely cold weather, the heat generated by the pump operation may not be enough to prevent freezing of the circulating fluid.**
- **During automatic operation, the pump does not stop operation even if the "RUN/STOP" key is pressed. To stop the pump, turn the power supply OFF or turn this function OFF.**



# Chapter 6 Option

## 6.1 Option List

The option must be specified when ordering the Thermo-chiller.(These options cannot be added after the purchase of the Thermo-chiller.) Options can be specified in any combination.

Symbol	Option	Description
C*1	With inverter for refrigerating machine	The cooling capacity of 60Hz can be obtained even in 50Hz area.
M	Deionized water (Pure water) piping	No copper-based materials are used in the wetted parts of the circulating fluid circuit.
P*1	With inverter for pump	Circulating fluid discharge pressure can be set. The pumping capacity at 60Hz can be obtained even in 50Hz areas.

\*1 : HRLE090 only.

## 6.2 Option C [With inverter for compressor]

By installing an inverter for the compressor, the cooling capacity can be increased to the same level as that of a 60 Hz region even in a 50 Hz region.

## 6.3 Option M [Deionized water (Pure water) piping]

No copper-based materials are used in the wetted parts of the circulating fluid circuit.

Wetted part materials are as follows.

Stainless (Include heat exchanger brazing), SiC, Carbon, FKM, PP, PE, POM, PVC, PA, EPDM, PTFE.

\*Serviceable conductivity: 0.4μS/cm or more. (Resistivity: 2.5MΩ·cm or less.)

## 6.4 Option P [With inverter for pump]

By installing an inverter for the pump, the pump capacity can be increased to the same level as that of a 60 Hz region even in a 50 Hz region.

In addition, the pressure can be set, and automatically controlled to any desired pressure without adjusting the valve opening.

Model No.: HRLE090- ※ -20/40

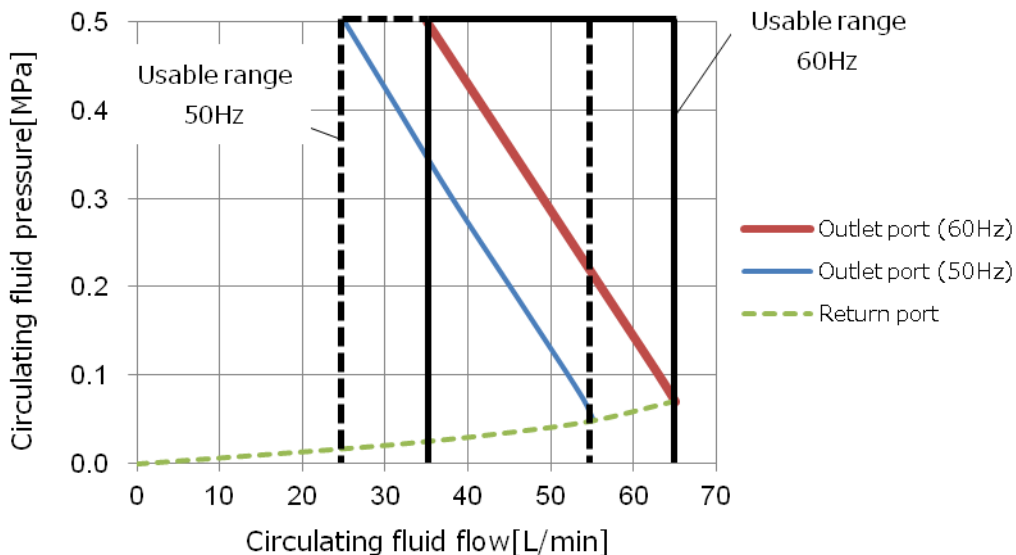

\* This pump capacity is flow rate of CH1 when flow rate of CH2 is 2L/min.

Fig. 6-1 Pump capacity diagram (standard product)

Model No.: HRLE090- ※ -20/40-P

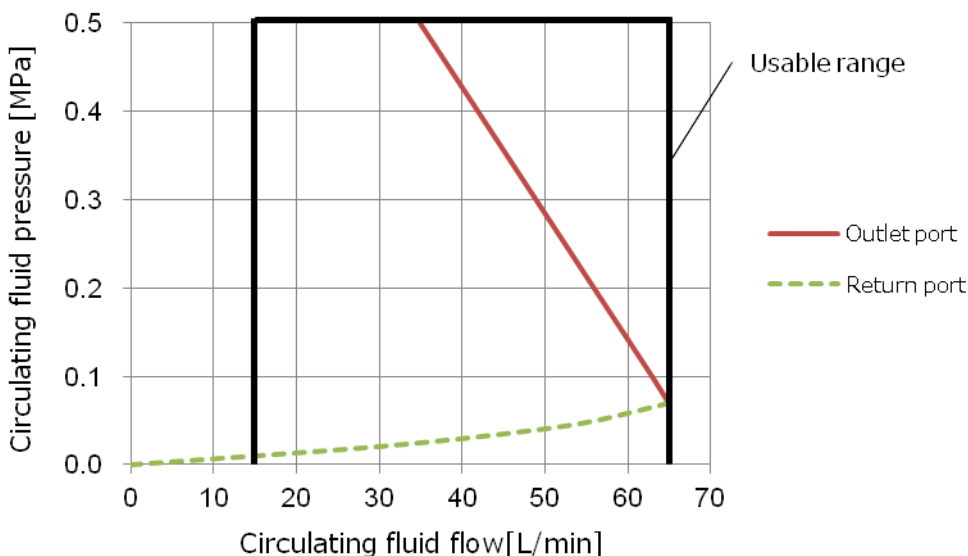

\* This pump capacity is flow rate of CH1 when flow rate of CH2 is 2L/min.

Fig. 6-2 Pump capacity diagram (Option P)

# Chapter 7 Alarm Notification and Troubleshooting

## 7.1 Alarm Notification

The product alerts the user in the order shown below when an alarm is generated.

- The [ALARM] light blinks.
- The alarm sound sounds.
- The alarm number is displayed in the PV window on the digital display.
- Contact signal of the contact input/output communication is output.
- You can read the alarm status using serial communication.
- This product has two types of operation depending on the alarm.

During operation of the product, some of the alarms stop its operation and some of them do not stop operation with an alarm.

Refer to "Table 7-1 Alarm codes and troubleshooting". When the operation stops due to an alarm, you cannot restart the operation until the alarm is reset.

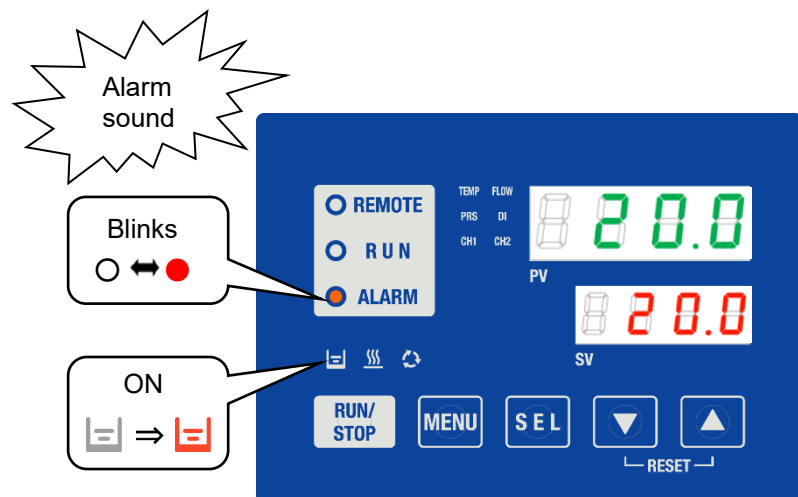

\* The [  ] light turns ON only when the "AL01 Low level in tank" alarm is generated.

When multiple alarms are generated, the alarm codes are displayed one by one by pressing the [SEL] key.

The total alarm number shown in the SV window on the digital display.

[Example of display]

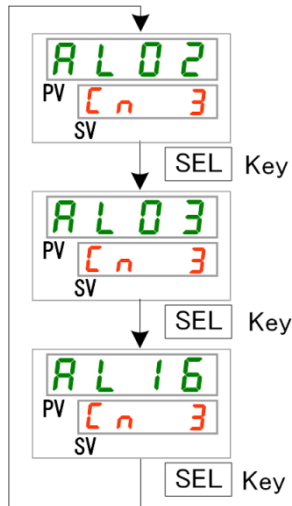

When alarms are generated in the order of AL16, AL03, and AL02:

The alarm code displayed on the operation panel is AL02, AL03 and AL16 are displayed by pressing the [SEL] key.



## 7.2 Alarm Sound Stop

An alarm sound

sounds to notify the user when an alarm is generated. How to stop the alarm sound is explained below.

- Confirm that the alarm display screen is shown.  
The alarm sound can be stopped only on this screen.
- Press the [▼] and [▲] buttons simultaneously.
- The alarm sound stops.

**Note**

- Alarm sounds can be set not to make sound. Refer to "5.7.2 Alarm sound setting"
- If this procedure is performed when the cause of the alarm has been eliminated before stopping the alarm sound, the alarm will be reset at the same time.

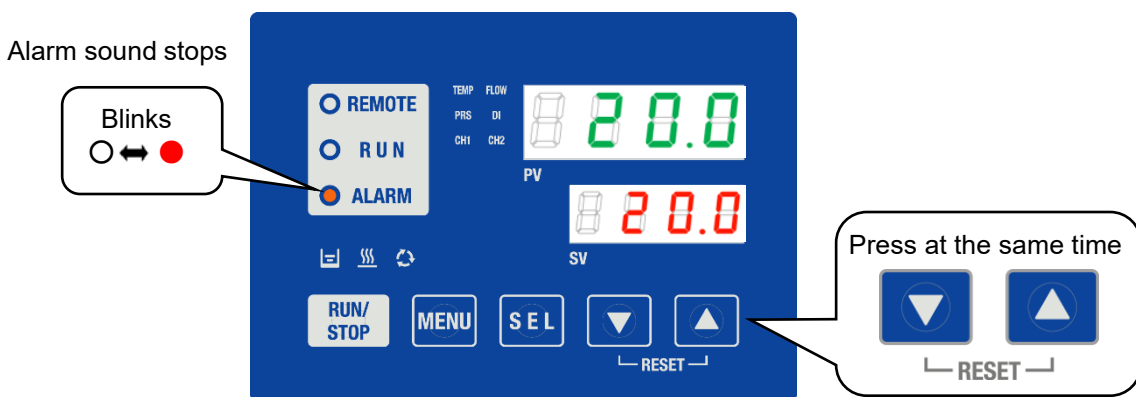

\* The [  ] light turns ON only when the "AL01 Low level in tank" alarm is generated.

## 7.3 Troubleshooting

### 7.3.1 Alarm details, causes, and troubleshooting

Troubleshooting method varies depending on which alarm has been generated. Refer to "Table 7-1 Alarm codes and troubleshooting" for handling.

This page explains how to reset the alarm after eliminating the cause of the alarm.

- Confirm that the alarm display screen is shown.
- Alarms can only be reset on this screen.
- Press the [▼] and [▲] buttons simultaneously.
- The alarm is reset.
- The [ALARM] light turns OFF.
- The operation panel displays the circulating fluid temperature and the set circulating fluid temperature.
- Contact signal output for contact input/output communication stops.
- (Refer to the Operation Manual Communication Function for details.)

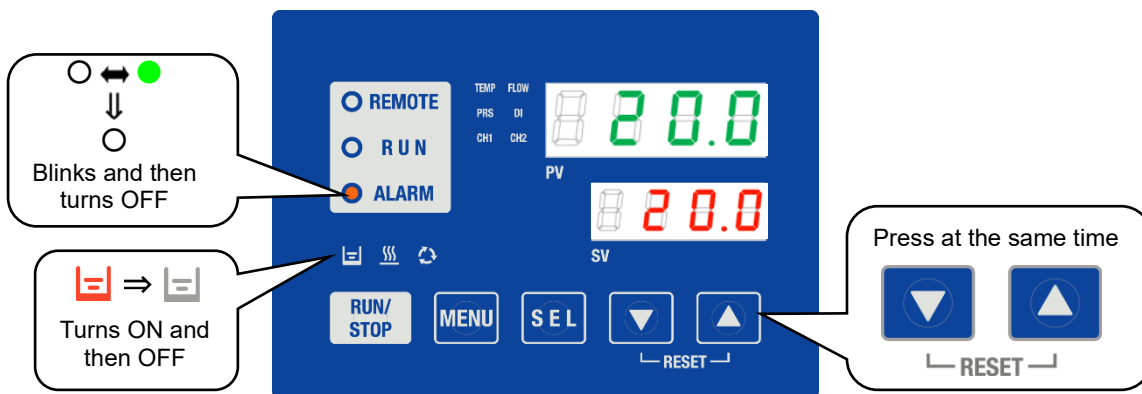

\* The [  ] light turns ON only when the "AL01 Low level in tank" alarm is generated.

Table 7-1 Alarm codes and troubleshooting

No.	Details	Operating conditions	Recovery	Possible causes	Countermeasures
AL01	Low level in tank	Stop	Manually	Low level in tank, broken wire in the liquid level sensor.	Check if there is a broken wire in the liquid level sensor, and add circulating fluid.
AL02	CH1 High circulating fluid temp.	Stop	Manually	High ambient temperature, high heat load.	Check the ambient temperature and heat load are within the specified ranges.
AL05	High circulating fluid return temp.	Stop	Manually	Circulating fluid not flowing, high heat load.	Check the circulating fluid flow and heat load are within the specified ranges.
AL06	High circulating fluid discharge pressure	Stop	Manually	Bent, pinched, clogged piping.	Check the user's piping for bends, pinching or clogging.
AL08	Circulating fluid discharge pressure rise	Stop <sup>(note1)</sup>	Manually	Bent, pinched, clogged piping.	Check the settings.
AL09	Circulating fluid discharge pressure drop	Stop <sup>(note1)</sup>	Manually	Failure of pump.	Check the pump is operating. Check the settings.
AL11	Low compressor suction temp.	Stop	Manually	Circulating fluid not flowing (low flow rate). Freezing in the circulating fluid in the heat exchanger.	Check the heat load circulating and fluid flow rate are within the specified ranges.
AL13	Abnormal high-side refrigerant pressure rise	Stop	Manually	High ambient temperature, high heat load. Clogging in the condenser or filter.	Check that the ambient temperature and heat load are within the specified ranges and that there is no clogging in the condenser and filter.
AL15	Refrigerant leakage	Stop	Manually	Refrigerant is leaking.	Ask for the service for the refrigerant circuite.
AL16	Abnormal low-side refrigerant pressure rise	Stop	Manually	High ambient temperature, high heat load.	Check the ambient temperature and heat load are within the specified ranges.
AL17	Abnormal low-side refrigerant pressure drop	Stop	Manually	Circulating fluid not flowing.	Check the circulating fluid flow is within the specified ranges.
AL18	Compressor running failure	Stop	Manually	Abnormality in the power supply (short circuit, voltage fluctuation, etc.). Failure of compressor.	Stop the chiller for 10 minutes, and then restart it. Check if the compressor operates. If it does not recover, ask for service to replace the compressor.
AL19	Communication error	Stop <sup>(note2)</sup>	Automatic	Error occurred in the communication.	Check the communication settings.
AL22	CH1 circulating fluid discharge temp. sensor failure	Stop	Manually	The temperature sensor is short-circuited or disconnected.	Ask for the service for the temperature sensor (PT1).
AL23	Circulating fluid return temp. sensor failure	Stop	Manually		Ask for the service for the temperature sensor (PT2).
AL24	Compressor suction temp. sensor failure	Stop	Manually		Ask for the service for the temperature sensor (TH2).
AL25	Circulating fluid discharge pressure sensor failure	Stop	Manually		Ask for the service for the pressure sensor (PS1).
AL26	Refrigerant circuit high pressure sensor failure	Stop	Manually	The pressure sensor is short-circuited or disconnected.	Ask for the service for the pressure sensor (PS2).
AL27	Refrigerant circuit low pressure sensor failure	Stop	Manually		Ask for the service for the pressure sensor (PS3).
AL31	Contact input 1 signal detection	Stop <sup>(note2)</sup>	Manually	Contact input has been detected.	Check the contact input.
AL32	Contact input 2 signal detection	Stop <sup>(note2)</sup>	Manually		If the error occurs again, ask for the service for the compressor.
AL34 <sup>(note3)</sup>	Electric conductivity rise	Operation continued	Automatic	Timing to replace the DI filter.	Replace the DI filter.
AL35 <sup>(note3)</sup>	Electric conductivity decrease	Operation continued	Automatic	Failure of solenoid valve.	Ask for the service for the solenoid valve.
AL36 <sup>(note3)</sup>	Electric conductivity sensor failure	Operation continued	Manually	Failure of DI sensor.	Ask for the service for the DI sensor.
AL37	Compressor discharge temp. sensor failure	Operation continued	Manually	The temperature sensor is short-circuited or disconnected.	Ask for the service for the temperature sensor (TH1).
AL38	Compressor discharge temp. rise	Stop	Manually	High ambient temperature, high heat load.	Check the ambient temperature and heat load are within the specified ranges.
AL43 <sup>(note4)</sup>	Fan failure	Stop	Manually	Failure of fan.	Ask for the service for the fan.
AL46 <sup>(note4)</sup>	Compressor inverter error	Stop	Manually	Error occurred in the compressor or inverter for compressor.	Ask for the service for the compressor/inverter of the compressor.
AL47 <sup>(note7)</sup>	Pump running failure	Stop	Manually	Error occurred in the pump.	Check the power supply is not error.(ground-fault, short-circuit, voltage fluctuation, abnormal phase voltage, open phase, surge, etc). Reset the thermal relay for the pump.
AL48 <sup>(note5)</sup>	Pump inverter error	Stop	Manually	Error occurred in the pump or inverter for pump.	Ask for the service for the pump/inverter of the pump.
AL50	CH2 Circulating fluid temp. is too high	Stop	Manually	High ambient temperature, high heat load.	Check the ambient temperature and heat load are within the specified ranges.
AL51	CH2 Circulating fluid discharge temp. sensor failure	Stop	Manually	The temperature sensor is short-circuited or disconnected.	Ask for the service for the temperature sensor (PT3).
AL52	Memory error 1	Stop	Restart	Abnormality in the power supply (short circuit, voltage fluctuation, etc.).	Check the power supply is not error.(ground-fault, short-circuit, voltage fluctuation, abnormal phase voltage, open phase, surge, etc), and restart the thermo chiller.
AL53	Memory error 2	Stop	Restart	Circuit board failure.	Check the power supply is not error.(ground-fault, short-circuit, voltage fluctuation, abnormal phase voltage, open phase, surge, etc), and restart the thermo chiller.
AL56 <sup>(note6)</sup>	Abnormal missing-phase / anti-phase	Stop	Manually	Error occurred in the power supply (miswiring).	Check the power supply is not error.(ground-fault, short-circuit, voltage fluctuation, abnormal phase voltage, open phase, surge, etc), and restart the thermo chiller.
AL57 <sup>(note4)</sup>	Compressor inverter communication error	Stop	Manually	Error occurred in the inverter for compressor.	Ask for the service for the inverter of the compressor.
AL58 <sup>(note5)</sup>	Pump inverter parameter error	Stop	Restart	Error occurred in the parameter of the inverter for pump.	Ask for the service for the inverter of the pump.
AL59 <sup>(note5)</sup>	Pump inverter communication error	Stop	Manually	Error occurred in the inverter for pump.	Ask for the service for the inverter of the pump.
AL62	Internal communication error	Stop	Restart	Abnormality in the power supply (short circuit, voltage fluctuation, etc.).	Check the power supply has no error.(ground-fault, short-circuit, voltage fluctuation, abnormal phase voltage, open phase, surge, etc) and restart the thermo chiller.
AL63	Abnormal high-side refrigerant pressure rise	Operation continued	Manually	High ambient temperature, high heat load. Clogging in the condenser or filter.	Check the ambient temperature and heat load are within the specified ranges.
AL64	Power supply failure	Stop	Restart	Error occurred in power supply.	Check the power supply and restart the thermo chiller.
AL65	Refrigerant high pressure switch operated	Stop	Manually	Failure of fan.	Ask for the service for the fan.
AL66 <sup>(note4)</sup>	Compressor inverter parameter error	Stop	Restart	Error occurred in the parameter of the inverter for compressor.	Ask for the service for the inverter of the compressor.

(Note 1) Initial value. User can change to Continued.  
 (Note 2) Initial value. User can change to Off or Continued.  
 (Note 3) Occurs only when the Electric conductivity control function is enabled.  
 (Note 4) Option C only. (HRLE090 only)  
 (Note 5) Option P only. (HRLE090 only)  
 (Note 6) Not generated for option C. (HRLE090 only)  
 (Note 7) Not generated for option P. (HRLE090 only)  
 (Note8) Not generated for Water-cooled refrigeration.

### 7.3.2 How to reset the refrigerant high pressure switch (When AL65 occurred)

#### **⚠ WARNING**



Be sure to lock out and tag out the breaker of the facility power supply (user's power supply) before removing the power supply terminal cover.

1. Turn off the power supply switch on the front surface.

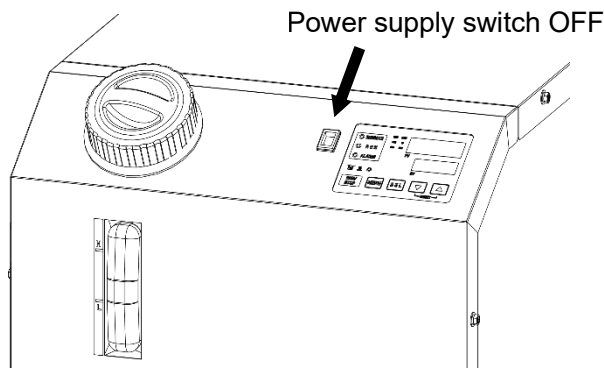

Fig. 7-1 Turn off

2. Turn OFF the earth leakage breaker of the user's power supply.

3. Remove the power supply terminal cover.

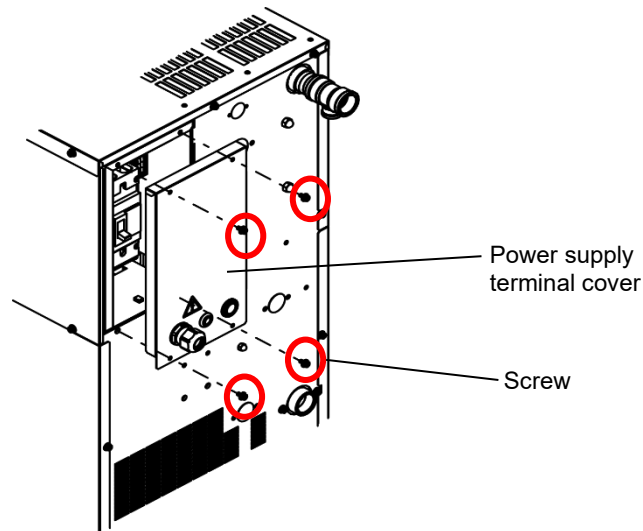

Fig. 7-2 Removing the power supply terminal cover

4. Turn off the breaker on the back side of the product.

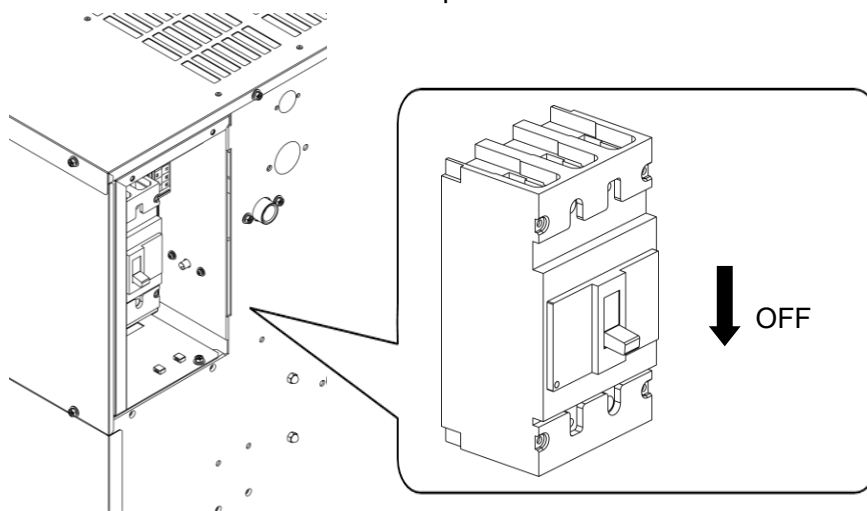

Fig. 7-3 Power supply shutoff

5. There is a high pressure switch reset button (red) as shown below. Press the red reset button to reset it.

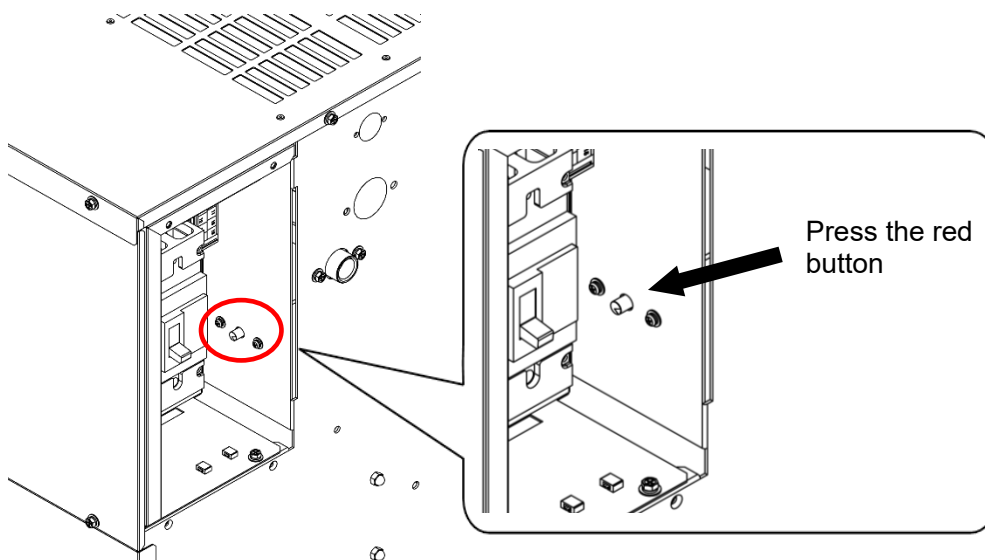

Fig. 7-4 High pressure switch reset

6. Performing the procedure in reverse, turn on the breaker on the back side of the product, mount the power supply terminal cover, turn on the user's power supply (power supply breaker), and turn on the power supply switch on the front surface.

**⚠ WARNING**

**Be sure to mount the power supply terminal cover before turning ON the breaker of the main power supply (the power supply of the user's facility), or it may cause an electric shock.**

## 7.4 Other Errors

### How to check other errors

Possible causes and countermeasures for failures with no alarm number display are shown in "Table 7-2".

Table 7-2 Possible causes and countermeasures for failures without an alarm number

Details of failure	Cause(s) of failure	Countermeasure
The operation panel displays nothing.	The breaker of the user's power supply or the product's power supply switch and breaker is not turned ON.	Turn on the power supply switch and breaker.
	The power supply switch or the breaker of the user's power supply or the product has failed.	Replace the breaker or the power supply switch.
	No power supply. (e.g., Breaker(s) in the power supply route have not been turned ON.)	Supply the power.
	The breaker for the user's facility or the product's breaker has tripped due to short-circuit or electricity leakage.	Repair the short-circuited part or the electricity leaking part.
The [RUN] light does not turn ON when the [RUN/STOP] button is pressed.	Communication setting has been turned ON.	Check if the communication setting has been turned ON.
	Failure of the [RUN] light	Replace the controller.
	Failure of the [RUN/STOP] button	Replace the controller.

\* Check the supply voltage with a tester.

# Chapter 8 Control, Inspection and Cleaning

## 8.1 Water Quality Management

### WARNING



Use specified circulating fluids only. If other fluids are used, they may damage the product or result in dangerous hazards.

When using tap water, SMC recommends the water quality shown in following table as reference.

In most areas, tap water can be used. However, if the tap water in the area is hard, there is a possibility of failure or performance decline due to limescale build-up. To soften the water and avoid problems, consider using water hardness filters.

Table 8-1 Water Quality Standard

	Item	Unit	Standard value	
			For circulating fluid	For facility water
Standard item	pH (25 °C)	-	6.0 to 8.0	6.5 to 8.2
	Electric conductance (at 25°C)	[μS/cm]	100 to 300	100 to 800
	Chloride ion	[mg/L]	50 or less	200 or less
	Sulphate ion	[mg/L]	50 or less	200 or less
	Acid consumption (at pH 4.8)	[mg/L]	50 or less	100 or less
	Total hardness	[mg/L]	70 or less	200 or less
	Calcium hardness	[mg/L]	50 or less	150 or less
Reference item	Ionic silica	[mg/L]	30 or less	50 or less
	Iron	[mg/L]	0.3 or less	1.0 or less
	Copper	[mg/L]	0.1 or less	0.3 or less
	Sulfide ion	[mg/L]	None should be detected	None should be detected
	Ammonium ion	[mg/L]	0.1 or less	1.0 or less
	Residual chlorine	[mg/L]	0.3 or less	0.3 or less
	Free carbon dioxide	[mg/L]	4.0 or less	4.0 or less

\* Quoted from the standard, "JRA-GL-02-1994", The Japan Refrigeration and Air Conditioning Industry Association.

### CAUTION



Replace the water in the tank if a problem is found in a regular inspection. Even if no problems are found, some of the water in the tank evaporates and the concentration of impurities in the circulating fluid increases. Replace the water in the tank once in every 3 months. Refer to section "8-2 Inspection and Cleaning" for regular inspection.

## 8.2 Inspection and Cleaning

**⚠ WARNING**



- Do not operate or change settings of this equipment with wet hands. Do not touch the electrical parts such as the power supply plug. It may cause an electric shock.
- Do not splash water directly on the product and do not wash it with water. It may cause an electric shock, fire, or etc.
- Do not touch the fins directly when cleaning the dust-proof filter. It may cause injury.

**⚠ WARNING**



- Shut off the power supply to this product before cleaning, maintenance or inspection, or it may cause electric shock, injury, burn, etc.
- When the panel has been removed for the purpose of inspection or cleaning, mount the panel after the work is completed. If the product is operated with the panel removed or open, it may cause injury or electric shock.

### 8.2.1 Daily check

Check the items listed below. If an abnormality is found, stop the operation of the product, turn the power supply OFF, and ask for service.

Table 8-2 Daily check items

Item	Content of check	
Installation conditions	Check the installation condition of the product.	<ul style="list-style-type: none"> <li>• Check that there is no heavy object on the product or excessive force being applied to the piping.</li> <li>• The temperature should be within the specification range of the product.</li> <li>• Make sure the ventilation grille is not obstructed. (Air-cooled refrigeration)</li> </ul>
Fluid leakage	Check the connected parts of the piping.	Check that there is no fluid leakage from the connected parts of the piping.
Amount of circulating fluid	Check the fluid level meter.	The fluid level should be between the "H" and "L" levels of the fluid level meter.
Operation panel	Check the indications on the display.	Numbers shown on the display should be clear and legible.
	Check the functionality.	Check that the buttons, [RUN/STOP], [MENU], [SEL], [▼], and [▲], operate correctly.
Circulating fluid temperature	Check on the operation panel.	There should be no problem for operation.
Circulating fluid discharge pressure	Check on the operation panel.	There should be no problem for operation.
Operating condition	Check the operating condition of the product.	<ul style="list-style-type: none"> <li>• There should be no abnormalities involving noise, vibration, smell, or generation of smoke.</li> <li>• There should be no active alarm signals.</li> </ul>
Ventilating condition (Air-cooled refrigeration)	Check the condition of the ventilation grille.	Make sure the ventilation grille is not obstructed.
Facility water (Water-cooled refrigeration)	Facility water condition	Temperature, puessure and flow rate are within the specified range of the product.



## 8.2.2 Monthly check

Table 8-3 Monthly check items

Item	Content of check	
Ventilating condition (Air-cooled refrigeration)	Clean the ventilation grille.	Make sure the ventilation grille is not clogged with dust, etc.

### ■ Clean the ventilation grille

#### CAUTION

**If the fins of the Air-cooled condenser become clogged with dust or debris, heat radiation performance declines. This will result in a reduction of the cooling performance, and may stop the operation if the safety device is triggered.**

Clean the dust-proof filters with a long-bristled brush or by blowing air to prevent the fins from being deformed or damaged.

### ■ Removal of the dust-proof filter

- 1.** A dust-proof filter is installed on the right side of the product.
- 
- 2.** Raise the dust-proof filter as shown below.  
Care should be taken not to deform or scratch the Air-cooled condenser (fins) while removing the filter.

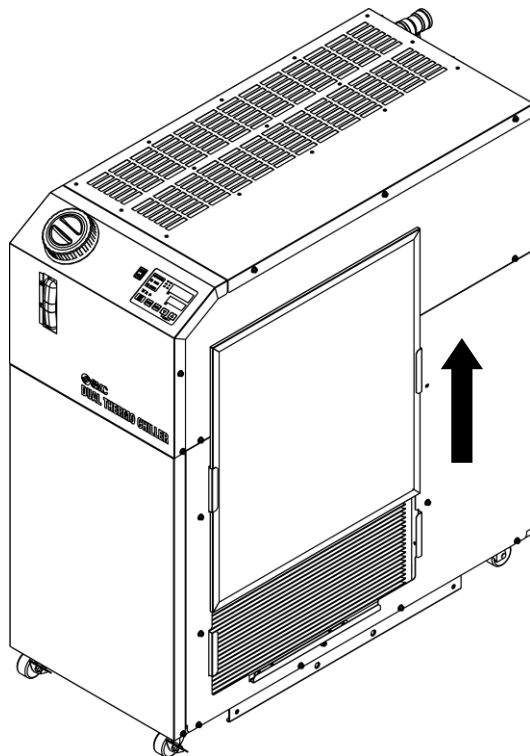

Fig. 8-1 Removal of the dust-proof filter

■ **Cleaning the dust-proof filter**

Clean the dust-proof filters with a long bristled brush or by blowing air.

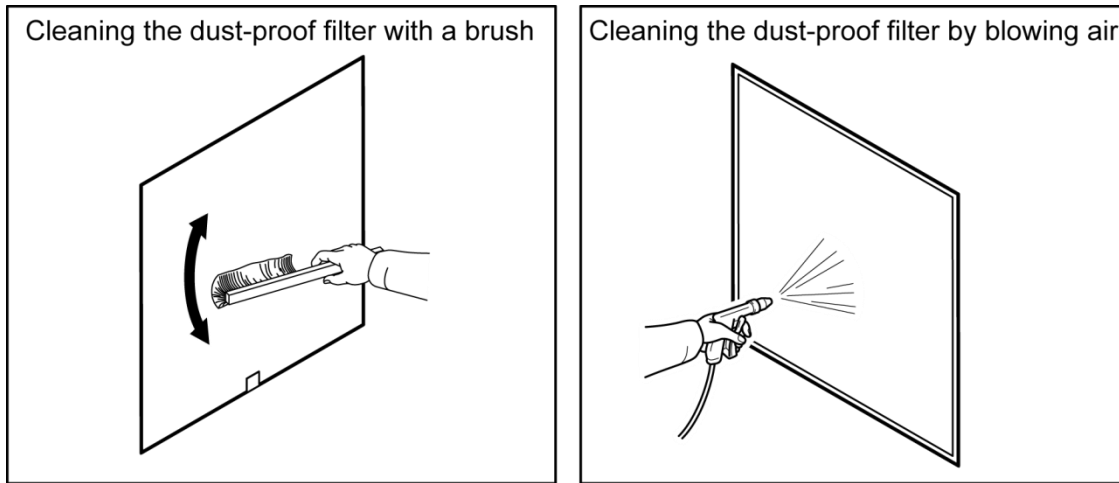

Fig. 8-2 Cleaning of the dust-proof filter

■ **Mounting the dust-proof filter**

Reassemble the filter in the reverse order to removal.

**8.2.3 3-month inspections**

Table 8-4 Content of 3-month inspections

Item	Content of check	
Power supply	Check the power supply voltage.	Make sure the supply voltage is within the specification range.
Circulating fluid	Replace the circulating water periodically.	<ul style="list-style-type: none"> <li>• Ensure that the water has not been contaminated and that there is no algae growth.</li> <li>• Circulating water inside the tank must be clean and there must not be foreign matter in it.</li> <li>• Check the water quality. (When using tap water)</li> </ul> <p>* About the water quality SMC recommends, please refer to "8.1Water Quality Management".</p> <p>* It is recommended to replace the circulating fluid every 3 months when periodic maintenance is performed.</p>

■ **Replacement of circulating fluid**

- Periodically replace the circulating fluid with new clear fluid, otherwise algae may grow or it may decompose. Replace the circulating fluid periodically depending on its condition.
- About the water quality SMC recommends for the circulating fluid, please refer to "8.1Water Quality Management".

■ **Replacement of facility water (For water cooled type)**

- Clean the customer's facility water system and replace facility water.
- About the water quality SMC recommends for the facility water, please refer to "8.18.1Water Quality Management".

## 8.2.4 6-month inspections

### ■ Check for water leakage from the pump

Remove the panel and inspect if there is abnormal leakage from the pump. If any leakage is found, the mechanical seal needs to be replaced. Order the mechanical seal described in "8.3 Consumables" as a service part.

#### CAUTION

- Leakage from the mechanical seal: It is impossible to prevent leakage from the mechanical seal completely because of its structure. The leakage is 3 cc/hr or less.
- The recommend life time of the mechanical seal before needing replacement is 6000 to 8000 hours.

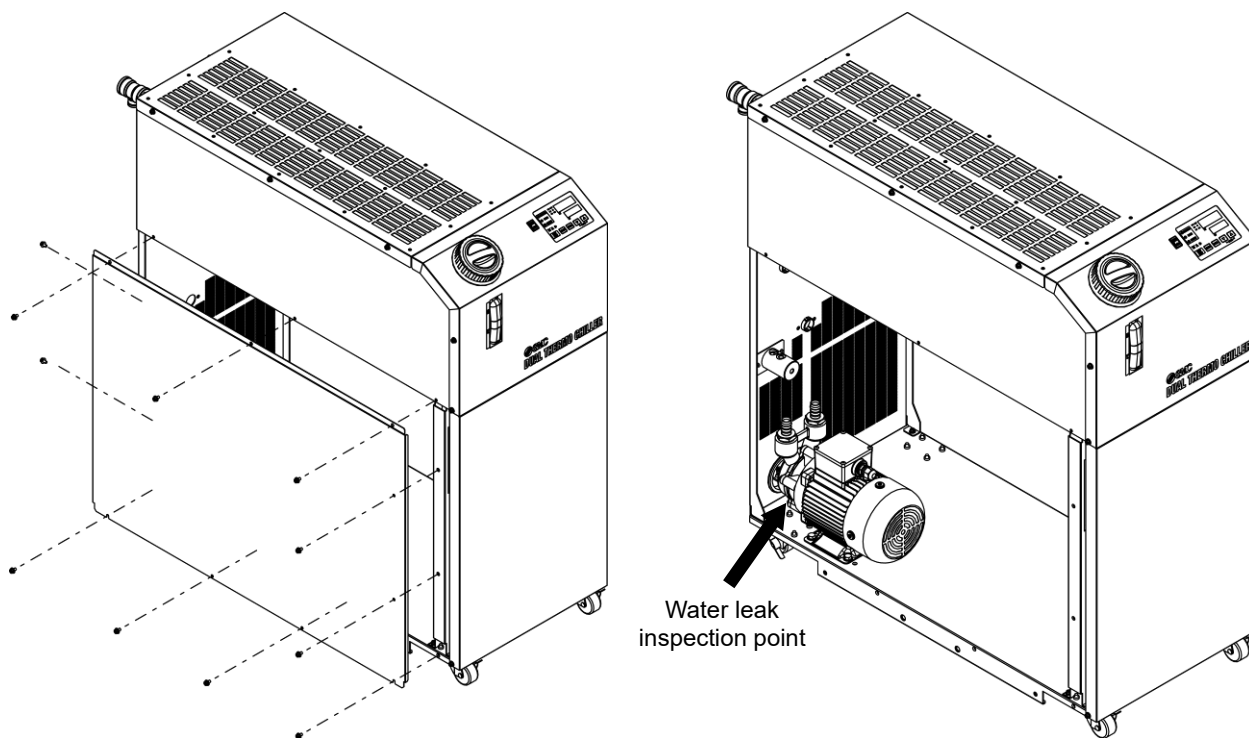

Fig. 8-3 Check for water leakage from the pump

## 8.2.5 Inspection during winter season

<b>CAUTION</b>	
	<b>Keep the power supply ON for this function. This function does not operate when the power is OFF.</b>

### ■ Anti-freezing function

This function prevents the circulating fluid from freezing while operation of the product is stopped in the winter season with heat generated by automatically operating the pump. When there is a possibility of the circulating fluid freezing due to changes in the installation or operating environment (e.g., season, weather), set this function ON in advance.

\* For more details, refer to "5.6.6 Anti-freezing function setting".

### ■ For freezing of the facility water

Please discharge the facility water from facility water circuit when there is fear of a freeze.

\*For the details, refer to "8.4.2 Drain of the facility water".

## 8.3 Consumables

Replace the parts shown in the table depending on the condition during inspection.

Table 8-5 Consumables

Part No.	Name	Qty.	Model No.		Remarks
			HRLE050	HRLE090	
IDF-S0535	Dust-proof filter	1	●	●	1 piece is used per unit
HRS-S0307	Mechanical seal set	1		●	1 set is used per unit
HRS-S0350	Mechanical seal set	1		●	1 set is used per unit (For option M)
HRR-DF001	DI filter	1	●	●	Please order when using HRL-DI001 and DI002.
HRS-S0211	Mechanical seal set	1	●		1 piece is used per unit

## 8.4 Operation Stop for an Extended Period of Time

If the product will not be operated for an extended period of time or there is a possibility of freezing in the winter time, take the measures according to the instructions shown below.

1. Turn OFF the earth leakage breaker of the user's power supply. (Turn off the power supply switch and the breaker in the panel.)
- 
2. Discharge all the circulating fluid completely from the product.  
Refer to "8.4.1  
Discharge of the circulating fluid" for how to discharge the circulating fluid.
- 
3. After discharging the circulating fluid, cover the product with a sheet before storing the product. (The sheet should be prepared by the user.)

### 8.4.1 Discharge of the circulating fluid

#### **WARNING**



- Before discharging the circulating fluid, stop the user's equipment and release the residual pressure.

#### **CAUTION**

- For relocation or long-term storage, drain as much of the residual liquid in the piping as possible. Residual liquid may drip during movement or installation.

1. Turn OFF the earth leakage breaker of the user's power supply.
- 
2. Open the ball valve at the drain port, and discharge the fluid.
- 
3. Confirm that all the circulating fluid has been discharged completely from the product and from the user's facility and piping, and then purge the circulating fluid port of the product with air.
- 
4. Close the ball valve after discharging the circulating fluid in the tank.

## 8.4.2 Drain of the facility water

### **⚠ WARNING**



- Stop the customer device and release the residual pressure before draining the facility water.

### **CAUTION**

- For relocation or long-term storage, drain the residual liquid in the piping as much as possible. Residual liquid may drip during movement or installation.

1. Shut off the breaker of the customer's power supply.
2. Stop supplying the facility water and make sure there is no pressure in the facility water piping.
3. Remove the facility water piping from the product.
4. Open the Left side panel then, open the air vent valve. The facility water in the product will be drained from the facility water inlet port.

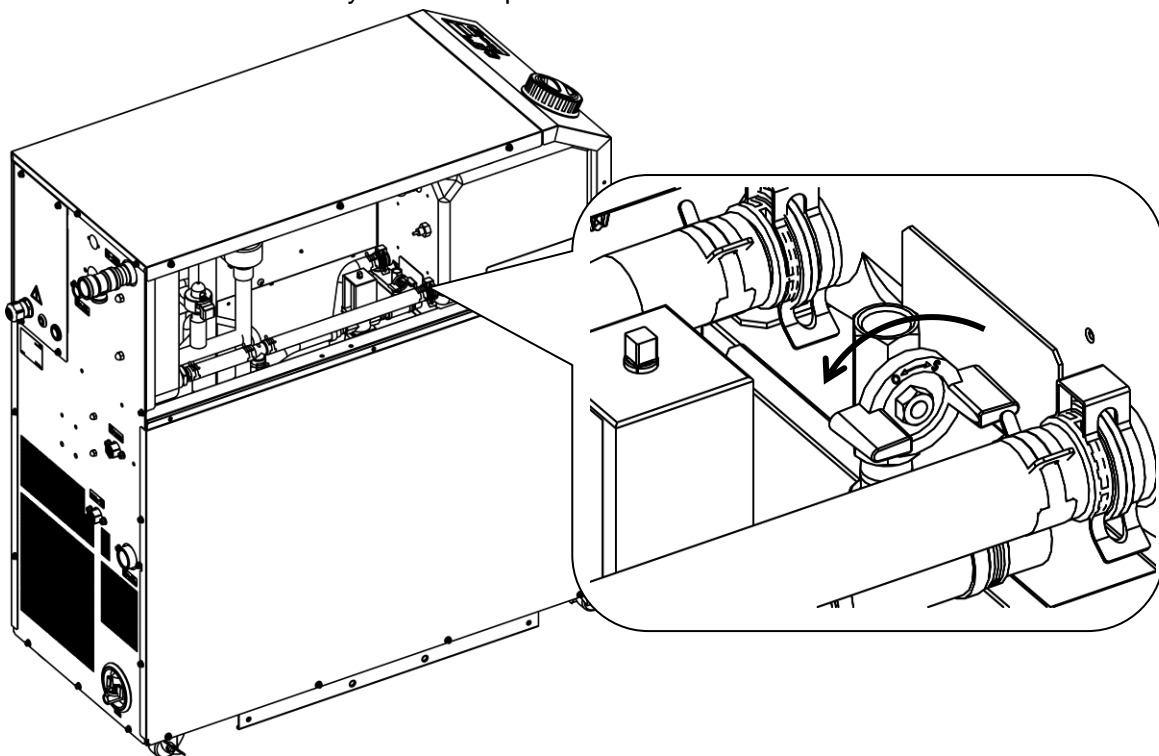

5. After draining, shut the air vent valve and close the Left side panel.

# Chapter 9 Documents

## 9.1 Specifications

### 9.1.1 HRLE050-A-20-\*

Table 9-1 Specifications [HRLE050-A-20-\*]

Model		HRLE050-A-20			
Cooling method		Air-cooled refrigeration			
Refrigerant		R410A(HFC)			
Quantity of refrigerant		kg	1.32		
Temperature control method		PID control			
Ambient temperature		°C	2 to 45		
Circulating fluid system	Circulating fluid <sup>(note1)</sup>		Tap water, Deionized(pure) water		
	Set temperature range		CH1 : 15 to 25, CH2 : CH1+0 to 15		
	Cooling capacity(Total of ch1 and 2) 50/60Hz <sup>(note2)</sup>		kW	4.8/5.8	
	Heating capacity(Total of ch1 and 2) 50/60Hz <sup>(note3)</sup>		kW	1.3/1.6	
	Temperature stability <sup>(note4)</sup>		°C	CH1 : ±0.1, CH2 : ±0.5	
	Pump capacity	Rated flow 50/60Hz <sup>(note5)</sup>		L/min	CH1 : 21/26, CH2 : 2/2
		Maximum flow rate 50/60Hz		L/min	29/38
		Maximum pump head 50/60Hz		m	34/50
	Minimum operating flow 50/60Hz <sup>(note6)</sup>		L/min	CH1 : 15/15, CH2 : 1/1	
	Tank capacity(Total of ch1 and 2)		L	Approx. 18	
	Fluid outlet, Fluid return port size		CH1 : Rc1/2, CH2 : Rc1/2		
	Drain port size		Rc1/4		
Fluid contact material		Stainless steel, Copper(Heat exchanger brazing), Bronze, Carbon, FKM, PP, PE, POM, PVC, PA, EPDM			
Fluid contact material(-M)		Stainless steel(Heat exchanger brazing), SiC, Carbon, FKM, PP, PE, POM, PVC, PA, EPDM, PTFE			
Electrical system	Power supply		Single-phase 200 to 230 VAC(50/60Hz) Allowable voltage range ±10%(No continuous voltage fluctuation)		
	Earth leakage breaker	Rated current	A	30	
		Sensitivity of leak current	mA	30	
	Rated operating current 50/60Hz		A	12.1/14.4	
Rated power consumption 50/60Hz		kW(kVA)	2.2/2.8(2.4/2.9)		
Communication function		Contact input/output, Serial RS-485			
Noise level <sup>(note7)</sup> 50/60Hz		dB(A)	62/64		
Accessory <sup>(note8)</sup>		Operation manual(for installation/operation) 2pcs. (English 1 pc./Japanese 1pc.), Anchor bolt brackets 2pcs.(including four M8 bolts), Cable accessory 1pc.(for communication cable)			
Weight <sup>(note9)</sup>		kg	114		

(Note1) Use fluid in condition below as the circulating fluid.

Tap water: please refer to "8.1Water Quality Management".

Deionized(pure) water : Electric conductance 0.4 µs/cm or more(Electrical resistivity 2.5MΩ/cm or less)

(Note2) (1)Ambient temp. : 25°C, (2)Circulating fluid : Tap water, (3)Circulating fluid temp. : CH1 : 20°C/CH2 : 25°C, (4)Circulating fluid rated flow, (5)Power supply : 200 VAC.

(Note3) (1)Ambient temp. : 25°C, (2)Circulating fluid : Tap water, (3)Circulating fluid rated flow, (4)Power supply : 200 VAC.

(Note4) (1)Ambient temp. : 25°C, (2)Circulating fluid : Tap water, (3)Circulating fluid temp. : CH1 : 20°C/CH2 : 25°C, (4)Circulating fluid rated flow, (5)Power supply : 200 VAC, (6)Piping length : Shortest, (7)Rated cooling load is applied.

(Note5) When circulating fluid outlet port pressure = 0.21/0.29MPa(50/60Hz)MPa.

(Note6) Fluid flow rate to maintain the cooling capacity. If the actual flow rate is lower than this, install a bypass piping.

(Note7) Front 1m/Height 1m.

(Note8) The anchor bolt fixing brackets(including four M8 bolts) are used for fixing to wooden skids when packaging the thermo-chiller. No anchor bolt is included.

(Note9) Weight when the circulating fluid is not included.

### 9.1.2 HRLE090-A-20-\*

Table 9-2 Specifications [HRLE090-A-20-\*

Model			HRLE090-A-20	
Cooling method			Air-cooled refrigeration	
Refrigerant			R410A(HFC)	
Quantity of refrigerant		kg	2	
Temperature control method			PID method	
Ambient temperature		°C	2 to 45	
Circulating fluid system	Circulating fluid <sup>(note1)</sup>		Tap water, Deionized(pure) water	
	Set temperature range		°C CH1 : 15 to 25, CH2 : CH1+0 to 15	
	Cooling capacity(Total of ch1 and 2) 50/60Hz <sup>(note2,10)</sup>		kW 8.0/9.5	
	Heating capacity(Total of ch1 and 2) 50/60Hz <sup>(note3)</sup>		kW 2.0/2.5	
	Temperature stability <sup>(note4)</sup>		°C CH1 : ±0.1, CH2 : ±0.5	
	Pump capacity	Rated flow 50/60Hz <sup>(note5,11)</sup>	L/min	CH1 : 25/35(0.5MPa), CH2 : 2/2(0.5MPa)
		Maximum flow rate 50/60Hz <sup>(note11)</sup>	L/min	55/65
		Maximum pump head	m	50
	Settable pressure range(-P)		MPa	0.1 to 0.5
	Minimum operating flow 50/60Hz <sup>(note6)</sup>		L/min	CH1 : 25/35(-P : 15), CH2 : 1/1
	Tank capacity(Total of ch1 and 2)		L	Approx. 18
	Fluid outlet, Fluid return port size			CH1 : Rc1, CH2 : Rc1/2
	Drain port size			Rc1/4
Fluid contact material			Stainless steel, Copper(Heat exchanger brazing), Bronze, Carbon, FKM, PP, PE, POM, PVC, PA, EPDM	
Fluid contact material(-M)			Stainless steel(Heat exchanger brazing), SiC, Carbon, FKM, PP, PE, POM, PVC, PA, EPDM, PTFE	
Electrical system	Power supply		3-phase 200 VAC(50Hz) Allowable voltage range ±10%(No continuous voltage fluctuation) 3-phase 200 to 230 VAC(60Hz) Allowable voltage range ±10%(No continuous voltage fluctuation)	
	Earth leakage breaker	Rated current	A 30	
		Sensitivity of leak current	mA 30	
	Rated operating current 50/60Hz		A 14/17	
	Rated power consumption 50/60Hz		kW(kVA) 4.3/5.3(4.9/5.8)	
Communication function			Contact input/output, Serial RS-485	
Noise level <sup>(note7)</sup>		dB(A)	65	
Accessory <sup>(note8)</sup>			Operation manual(for installation/operation) 2pcs. (English 1 pc./Japanese 1pc.), Anchor bolt brackets 2pcs.(including four M8 bolts), Cable accessory 1pc.(for communication cable)	
Weight <sup>(note9,12)</sup>		kg	140	

(Note1) Use fluid in condition below as the circulating fluid.

Tap water: please refer to "8.1Water Quality Management".

Deionized(pure) water : Electric conductance 0.4 μs/cm or more(Electrical resistivity 2.5MΩ/cm or less)

(Note2) (1)Ambient temp. : 32°C, (2)Circulating fluid : Tap water, (3)Circulating fluid temp. : CH1 : 20°C/CH2 : 25°C, (4)Circulating fluid rated flow, (5)Power supply : 200 VAC.

(Note3) (1)Ambient temp. : 32°C, (2)Circulating fluid : Tap water, (3)Circulating fluid rated flow, (4)Power supply : 200 VAC.

(Note4) (1)Ambient temp. : 32°C, (2)Circulating fluid : Tap water, (3)Circulating fluid temp. : CH1 : 20°C/CH2 : 25°C, (4)Circulating fluid rated flow, (5)Power supply : 200 VAC, (6)Piping length : Shortest, (7)Rated cooling load is applied.

(Note5) Circulating fluid temperature: CH1: 20°C/CH2: 25°C at the device outlet.

(Note6) Flow rate required to maintain cooling capacity.Install bypass piping if the flow rate is less than the minimum required flow rate.

(Note7) Front 1m/Height 1m.

(Note8) The anchor bolt fixing brackets(including four M8 bolts) are used for fixing to wooden skids when packaging the thermo-chiller.

No anchor bolt is included.

(Note9) Weight when the circulating fluid is not included.

(Note10) The capacity is 60Hz even in the 50Hz area when option C is selected.

(Note11) The capacity is 60Hz even in the 50Hz area when option P is selected.

(Note12) The weight will increase by 4kg when option C and P is selected.



### 9.1.3 HRLE050-W-20-\*

Table 9-3 Specifications [HRLE050-W-20-\*

Model		HRLE050-W-20		
Cooling method		Water-cooled refrigeration		
Refrigerant		R410A(HFC)		
Quantity of refrigerant		kg	1.2	
Temperature control method		PID control		
Ambient temperature		°C	2 to 45	
Circulating fluid system	Circulating fluid <sup>(note1)</sup>		Tap water, Deionized(pure) water	
	Set temperature range		°C CH1 : 15 to 25, CH2 : CH1+0 to 15	
	Cooling capacity(Total of ch1 and 2) 50/60Hz <sup>(note2)</sup>		kW 4.8/5.8	
	Heating capacity(Total of ch1 and 2) 50/60Hz <sup>(note3)</sup>		kW 1.2/1.5	
	Temperature stability <sup>(note4)</sup>		°C CH1 : ±0.1, CH2 : ±0.5	
	Pump capacity	Rated flow 50/60Hz <sup>(note5)</sup>	L/min	CH1 : 21/26, CH2 : 2/2
		Maximum flow rate 50/60Hz	L/min	29/38
		Maximum pump head 50/60Hz	m	34/50
	Minimum operating flow 50/60Hz <sup>(note6)</sup>		L/min	CH1 : 15/15, CH2 : 1/1
	Tank capacity(Total of ch1 and 2)		L	Approx. 18
Fluid outlet, Fluid return port size		CH1 : Rc1/2, CH2 : Rc1/2		
Drain port size		Rc1/4		
Fluid contact material		Stainless steel, Copper(Heat exchanger brazing), Bronze, Carbon, FKM, PP, PE, POM, PVC, PA, EPDM		
Fluid contact material(-M)		Stainless steel(Heat exchanger brazing), SiC, Carbon, FKM, PP, PE, POM, PVC, PA, EPDM, PTFE		
Facility water system	Temperature range		°C 5~40	
	Pressure range		MPa 0.3~0.5	
	Required flow 50/60Hz <sup>(note7)</sup>		L/min 16	
	Facility water pressure differential		MPa 0.3 or more	
	Facility water inlet/outlet		Rc1/2	
Fluid contact material		Stainless steel, Copper(Heat exchanger brazing), Brass, Carbon, PTFE, NBR, EPDM		
Electrical system	Power supply		Single-phase 200 to 230 VAC(50/60Hz) Allowable voltage range ±10%(No continuous voltage fluctuation)	
	Earth leakage breaker	Rated current	A 30	
		Sensitivity of leak current	mA 30	
	Rated operating current 50/60Hz		A 10.9/12.7	
Rated power consumption 50/60Hz		kW(kVA) 2.0/2.4(2.1/2.5)		
Communication function		Contact input/output, Serial RS-485		
Noise level <sup>(note8)</sup> 50/60Hz		dB(A)	62/64	
Accessory <sup>(note9)</sup>		Operation manual(for installation/operation) 2pcs. (English 1 pc./Japanese 1pc.), Anchor bolt brackets 2pcs.(including four M8 bolts), Cable accessory 1pc.(for communication cable)		
Weight <sup>(note10)</sup>		kg	107	

(Note1) Use fluid in condition below as the circulating fluid.

Tap water: please refer to "8.1Water Quality Management".

Deionized(pure) water : Electric conductance 0.4 μs/cm or more(Electrical resistivity 2.5MΩ/cm or less)

(Note2) (1)Facility water temp. : 25°C, (2)Circulating fluid : Tap water, (3)Circulating fluid temp. : CH1 : 20°C/CH2 : 25°C, (4)Circulating fluid rated flow, (5)Power supply : 200 VAC.

(Note3) (1)Facility water temp. : 25°C, (2)Circulating fluid : Tap water, (3)Circulating fluid rated flow, (4)Power supply : 200 VAC.

(Note4) (1)Facility water temp.: 25°C, (2)Circulating fluid : Tap water, (3)Circulating fluid temp. : CH1 : 20°C/CH2 : 25°C, (4)Circulating fluid rated flow, (5)Power supply : 200 VAC, (6)Piping length : Shortest, (7)Rated cooling load is applied.

(Note5) When circulating fluid outlet port pressure = 0.21/0.29MPa(50/60Hz)MPa.

(Note6) Fluid flow rate to maintain the cooling capacity. If the actual flow rate is lower than this, install a bypass piping.

(Note7) The flow rate required when the load described in the cooling capacity is applied at a circulating fluid temperature of 20°C, circulating fluid rated flow rate, and facility water temperature of 25°C.

(Note8) Front 1m/Height 1m.

(Note9) The anchor bolt fixing brackets(including four M8 bolts) are used for fixing to wooden skids when packaging the thermo-chiller. No anchor bolt is included.

(Note10) Weight when the circulating fluid is not included.

### 9.1.4 HRLE090-W-20-\*

Table 9-4 Specifications [HRLE090-W-20-\*

Model		HRLE090-W-20		
Cooling method		Water-cooled refrigeration		
Refrigerant		R410A(HFC)		
Quantity of refrigerant		kg	1.9	
Temperature control method		PID control		
Ambient temperature		°C	2 to 45	
Circulating fluid system	Circulating fluid <sup>(note1)</sup>		Tap water, Deionized(pure) water	
	Set temperature range		°C CH1 : 15 to 25, CH2 : CH1+0 to 15	
	Cooling capacity(Total of ch1 and 2) 50/60Hz <sup>(note2,10)</sup>		kW 9.5/11.0	
	Heating capacity(Total of ch1 and 2) 50/60Hz <sup>(note3)</sup>		kW 2.0/2.5	
	Temperature stability <sup>(note4)</sup>		°C CH1 : ±0.1, CH2 : ±0.5	
	Pump capacity	Rated flow 50/60Hz <sup>(note5,11)</sup>		L/min CH1 : 25/35(0.5MPa), CH2 : 2/2(0.5MPa)
		Maximum flow rate 50/60Hz <sup>(note11)</sup>		L/min 55/65
		Maximum pump head		m 50
	Settable pressure range(-P)		MPa 0.1 to 0.5	
	Minimum operating flow 50/60Hz <sup>(note6)</sup>		L/min CH1 : 25/35(-P : 15), CH2 : 1/1	
	Tank capacity(Total of ch1 and 2)		L Approx. 18	
	Fluid outlet, Fluid return port size		CH1 : Rc1, CH2 : Rc1/2	
	Drain port size		Rc1/4	
Fluid contact material		Stainless steel, Copper(Heat exchanger brazing), Bronze, Carbon, FKM, PP, PE, POM, PVC, PA, EPDM		
Fluid contact material(-M)		Stainless steel(Heat exchanger brazing), SiC, Carbon, FKM, PP, PE, POM, PVC, PA, EPDM, PTFE		
Facility water system	Temperature range		°C 5~40	
	Pressure range		MPa 0.3~0.5	
	Required flow 50/60Hz		L/min 25/25	
	Facility water pressure differential		MPa 0.3 or more	
	Facility water inlet/outlet		Rc1/2	
	Fluid contact material		Stainless steel, Copper(Heat exchanger brazing), Brass, Carbon, PTFE, NBR, EPDM	
Electrical system	Power supply		3-phase 200 VAC(50Hz) Allowable voltage range ±10%(No continuous voltage fluctuation) 3-phase 200 to 230 VAC(60Hz) Allowable voltage range ±10%(No continuous voltage fluctuation)	
	Earth leakage breaker	Rated current		A 30
		Sensitivity of leak current		mA 30
	Rated operating current 50/60Hz		A 13.5/14.4	
	Rated power consumption 50/60Hz		kW(kVA) 3.5/4.4(4.7/5.0)	
Communication function		Contact input/output, Serial RS-485		
Noise level <sup>(note7)</sup>		dB(A)	65	
Accessory <sup>(note8)</sup>		Operation manual(for installation/operation) 2pcs. (English 1 pc./Japanese 1pc.), Anchor bolt brackets 2pcs.(including four M8 bolts), Cable accessory 1pc.(for communication cable)		
Weight <sup>(note9,12)</sup>		kg	134	

- (Note1) Use fluid in condition below as the circulating fluid.  
 Tap water: please refer to "8.1Water Quality Management".  
 Deionized water : Electric conductance 0.4 μS/cm or higher (Electrical resistivity 2.5MΩ·cm or lower)
- (Note2) (1)Facility water temp. : 32°C, (2)Circulating fluid : Tap water, (3)Circulating fluid temp. : CH1:20°C/CH2:25°C,  
 (4)Circulating fluid rated flow:Rated flow, (5)Power supply : 200 VAC.
- (Note3) (1)Facility water temp. : 32°C, (2)Circulating fluid : Tap water, (3)Circulating fluid flow rate:Rated flow, (4)Power supply : 200 VAC.
- (Note4) (1)Facility water temp. : 32°C, (2)Circulating fluid : Tap water, (3)Circulating fluid temp. : CH1:20°C/CH2:25°C,  
 (4)Circulating fluid flow rate:Rated flow, (5)Power supply : 200 VAC, (6)Piping length : Shortest, (7)Load: Same as the cooling capacity.
- (Note5) Circulating fluid temperature: CH1: 20°C/CH2: 25°C at the device outlet.
- (Note6) Flow rate required to maintain cooling capacity.Install bypass piping if the flow rate is less than the minimum required flow rate.
- (Note7) Front 1m/Height 1m.
- (Note8) The anchor bolt fixing brackets(includes 4 M8 bolts) are used for securing the product to wooden skids when packaging the thermo-chiller.The anchor bolt is not included.
- (Note9) Weight when the circulating fluid is not included.
- (Note10) The capacity is 60Hz even in the 50Hz area when option C is selected.
- (Note11) The capacity is 60Hz even in the 50Hz area when option P is selected.
- (Note12) The weight will increase by 4kg when option C and P is selected.

## 9.1.5 HRLE090-A-40-\*

Table 9-5 Specifications [HRLE090-A-40-\*

Model		HRLE090-A-40		
Cooling method		Air-cooled refrigeration		
Refrigerant		R410A(HFC)		
Quantity of refrigerant		kg	2	
Temperature control method		PID method		
Ambient temperature		°C	2 to 45	
Circulating fluid system	Circulating fluid <sup>(note1)</sup>		Tap water, Deionized(pure) water	
	Set temperature range		°C CH1 : 15 to 25, CH2 : CH1+0 to 15	
	Cooling capacity(Total of ch1 and 2) 50/60Hz <sup>(note2,11)</sup>		kW 8.0/9.5	
	Heating capacity(Total of ch1 and 2) 50/60Hz <sup>(note3)</sup>		kW 2.0/2.5	
	Temperature stability <sup>(note4)</sup>		°C CH1 : ±0.1, CH2 : ±0.5	
	Pump capacity	Rated flow 50/60Hz <sup>(note5,12)</sup>		L/min CH1 : 25/35(0.5MPa), CH2 : 2/2(0.5MPa)
		Maximum flow rate 50/60Hz <sup>(note12)</sup>		L/min 55/65
		Maximum pump head		m 50
	Settable pressure range(-P)		MPa 0.1 to 0.5	
	Minimum operating flow 50/60Hz <sup>(note6)</sup>		L/min CH1 : 25/35(-P : 15), CH2 : 1/1	
	Tank capacity(Total of ch1 and 2)		L Approx. 18	
	Fluid outlet, Fluid return port size		CH1 : Rc1, CH2 : Rc1/2	
	Drain port size		Rc1/4	
Fluid contact material		Stainless steel, Copper(Heat exchanger brazing), Bronze, Carbon, FKM, PP, PE, POM, PVC, PA, EPDM		
Fluid contact material(-M)		Stainless steel(Heat exchanger brazing), SiC, Carbon, FKM, PP, PE, POM, PVC, PA, EPDM, PTFE		
Electrical system	Power supply		3-phase 380V to 415 VAC(50/60Hz) Allowable voltage range ±10%(No continuous voltage fluctuation) 3-phase 460 to 480 VAC(60Hz) Allowable voltage range +4%/-10% (Maximam voltage is 500V and no continuous voltage fluctuation)	
	Applicable Earth leakage breaker <sup>(note7)</sup>	Rated current	A 20	
		Sensitivity of leak current	mA 30	
	Rated operating current 50/60Hz		A 6.8/8.2	
	Rated power consumption 50/60Hz		kW(kVA) 4.3/5.3(4.9/5.8)	
Communication function		Contact input/output, Serial RS-485		
Noise level <sup>(note8)</sup>		dB(A) 67		
Accessory <sup>(note9)</sup>		Operation manual(for installation/operation)2pcs. (English 1 pc./Japanese 1pc.), Anchor bolt brackets 2pcs.(including four M8 bolts), Cable accessory 1pc.(for communication cable)		
Weight <sup>(note10,13)</sup>		kg 140		

(Note1) Use fluid in condition below as the circulating fluid.

Tap water: please refer to "8.1Water Quality Management".

Deionized(pure) water : Electric conductance 0.4 µs/cm or more(Electrical resistivity 2.5MΩ/cm or less)

(Note2) (1)Ambient temp. : 32°C, (2)Circulating fluid : Tap water, (3)Circulating fluid temp. : CH1 : 20°C/CH2 : 25°C, (4)Circulating fluid rated flow, (5)Power supply : 400 VAC.

(Note3) (1)Ambient temp. : 32°C, (2)Circulating fluid : Tap water, (3)Circulating fluid rated flow, (4)Power supply : 400 VAC.

(Note4) (1)Ambient temp. : 32°C, (2)Circulating fluid : Tap water, (3)Circulating fluid temp. : CH1 : 20°C/CH2 : 25°C, (4)Circulating fluid rated flow, (5)Power supply : 400 VAC, (6)Piping length : Shortest, (7)Rated cooling load is applied.

(Note5) Circulating fluid temperature: CH1: 20°C/CH2: 25°C at the device outlet.

(Note6) Flow rate required to maintain cooling capacity.Install bypass piping if the flow rate is less than the minimum required flow rate.

(Note7) To be prepared by the user.

(Note8) Front 1m/Height 1m.

(Note9) The anchor bolt fixing brackets(including four M8 bolts) are used for fixing to wooden skids when packaging the thermo-chiller. No anchor bolt is included.

(Note10) Weight when the circulating fluid is not included.

(Note11) The capacity is 60Hz even in the 50Hz area when option C is selected.

(Note12) The capacity is 60Hz even in the 50Hz area when option P is selected.

(Note13) The weight will increase by 4kg when option C and P is selected.

### 9.1.6 HRLE090-W-40-\*

Table 9-6 Specifications [HRLE090-W-40-\*

Model		HRLE090-W-40		
Cooling method		Water-cooled refrigeration		
Refrigerant		R410A(HFC)		
Quantity of refrigerant	kg	1.9		
Temperature control method		PID method		
Ambient temperature		℃		
Circulating fluid system	Circulating fluid <sup>(note1)</sup>		Tap water, Deionized(pure) water	
	Set temperature range		CH1 : 15 to 25, CH2 : CH1+0 to 15	
	Cooling capacity(Total of ch1 and 2) 50/60Hz <sup>(note2,11)</sup>		kW 9.5/11.0	
	Heating capacity(Total of ch1 and 2) 50/60Hz <sup>(note3)</sup>		kW 2.0/2.5	
	Temperature stability <sup>(note4)</sup>		℃ CH1 : ±0.1, CH2 : ±0.5	
	Pump capacity	Rated flow 50/60Hz <sup>(note5,12)</sup>		L/min CH1 : 25/35(0.5MPa), CH2 : 2/2(0.5MPa)
		Maximum flow rate 50/60Hz <sup>(note12)</sup>		L/min 55/65
		Maximum pump head		m 50
	Settable pressure range(-P)		MPa 0.1 to 0.5	
	Minimum operating flow 50/60Hz <sup>(note6)</sup>		L/min CH1 : 25/35(-P : 15), CH2 : 1/1	
	Tank capacity(Total of ch1 and 2)		L Approx. 18	
	Fluid outlet, Fluid return port size		CH1 : Rc1, CH2 : Rc1/2	
Drain port size		Rc1/4		
Fluid contact material		Stainless steel, Copper(Heat exchanger brazing), Bronze, Carbon, FKM, PP, PE, POM, PVC, PA, EPDM		
Fluid contact material(-M)		Stainless steel(Heat exchanger brazing), SiC, Carbon, FKM, PP, PE, POM, PVC, PA, EPDM, PTFE		
Facility water system	Temperature range		℃ 5~40	
	Pressure range		MPa 0.3~0.5	
	Required flow 50/60Hz		L/min 25/25	
	Facility water pressure differential		MPa 0.3 or more	
	Facility water inlet/outlet		Rc1/2	
	Fluid contact material		Stainless steel, Copper(Heat exchanger brazing), Brass, Carbon, PTFE, NBR, EPDM	
Electrical system	Power supply		3-phase 380 to 415 VAC(50/60Hz) Allowable voltage range ±10%(No continuous voltage fluctuation) 3-phase 460 to 480 VAC(60Hz) Allowable voltage range +4%/-10% (Maximum voltage is 500V and no continuous voltage fluctuation)	
	Applicable Earth leakage breaker <sup>(note7)</sup>	Rated current	A 20	
		Sensitivity of leak current	mA 30	
	Rated operating current 50/60Hz		A 6.7/7.1	
	Rated power consumption 50/60Hz		kW(kVA) 3.5/4.4(4.7/5.0)	
Communication function		Contact input/output, Serial RS-485		
Noise level <sup>(note8)</sup>		dB(A) 65		
Accessory <sup>(note9)</sup>		Operation manual(for installation/operation)2pcs. (English 1 pc./Japanese 1pc.), Anchor bolt brackets 2pcs.(including four M8 bolts), Cable accessory 1pc.(for communication cable)		
Weight <sup>(note10,13)</sup>		kg 134		

- (Note1) Use fluid in condition below as the circulating fluid.  
 Tap water: please refer to "8.1Water Quality Management".  
 Deionized water : Electric conductance 0.4 μS/cm or higher (Electrical resistivity 2.5MΩ·cm or lower)
- (Note2) (1)Facility water temp. : 32℃, (2)Circulating fluid : Tap water, (3)Circulating fluid temp. : CH1:20℃/CH2:25℃,  
 (4)Circulating fluid rated flow:Rated flow, (5)Power supply : 400 VAC.
- (Note3) (1)Facility water temp. : 32℃, (2)Circulating fluid : Tap water, (3)Circulating fluid flow rate:Rated flow, (4)Power supply : 400 VAC.
- (Note4) (1)Facility water temp. : 32℃, (2)Circulating fluid : Tap water, (3)Circulating fluid temp. : CH1:20℃/CH2:25℃,  
 (4)Circulating fluid flow rate:Rated flow, (5)Power supply : 400 VAC, (6)Piping length : Shortest, (7)Load: Same as the cooling capacity.
- (Note5) Circulating fluid temperature: CH1: 20℃/CH2: 25℃ at the device outlet.
- (Note6) Flow rate required to maintain cooling capacity.Install bypass piping if the flow rate is less than the minimum required flow rate. (Note7) To be prepared by the customer.
- (Note8) Front 1m/Height 1m.
- (Note9) The anchor bolt fixing brackets(includes 4 M8 bolts) are used for securing the product to wooden skids when packaging the thermo-chiller.The anchor bolt is not included.
- (Note10) Weight when the circulating fluid is not included.
- (Note11) The capacity is 60Hz even in the 50Hz area when option C is selected.
- (Note12) The capacity is 60Hz even in the 50Hz area when option P is selected.
- (Note13) The weight will increase by 4kg when option C and P is selected.

## 9.2 Refrigerant and GWP Value

Table 9-7 Refrigerant and GWP value

Refrigerant	Global Warming Potential (GWP)		
	Regulation (EU)2024/573 AIM Act 40 CFR Part 84	Fluorocarbon Emission Control Law (Japanese law)	
		Revised Fluorocarbons Recovery and Destruction Law	Calculated leakage amount, etc. Reporting Notification Factor
R134a	1,430	1,430	1,300
R404A	3,922	3,920	3,940
R407C	1,774	1,770	1,620
R410A	2,088	2,090	1,920
R448A	1,386	1,390	1,270
R454C	146	145	146

Notes:

1. The product contains a greenhouse gas.
2. Refer to the product specifications for the type of refrigerant.

# 9.3 Dimensions

## 9.3.1 HRLE050-A-20-\*

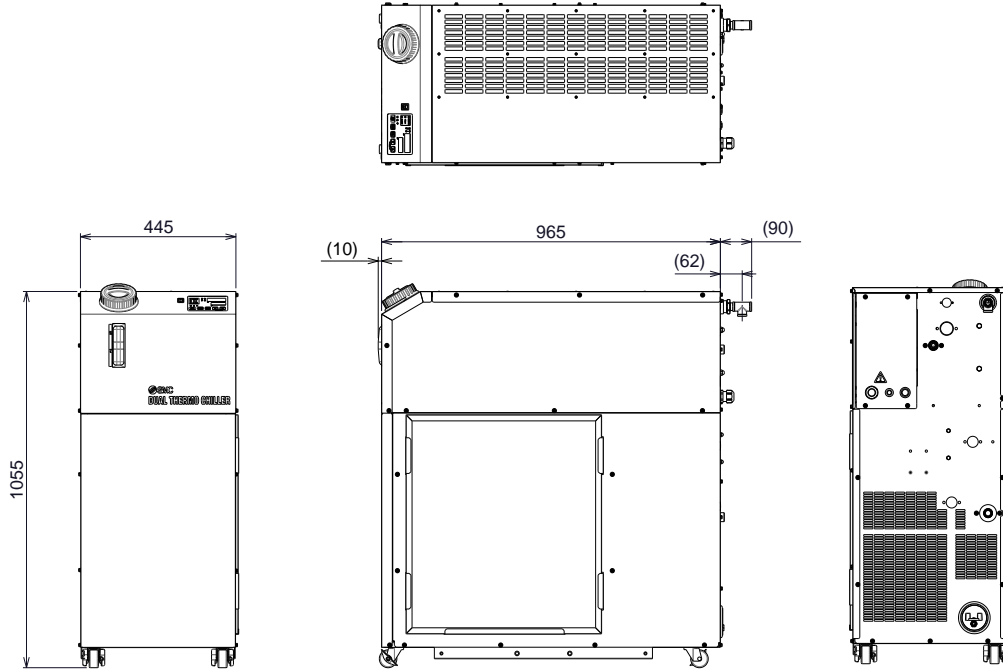

Unit:mm

Fig. 9-1 Dimensions

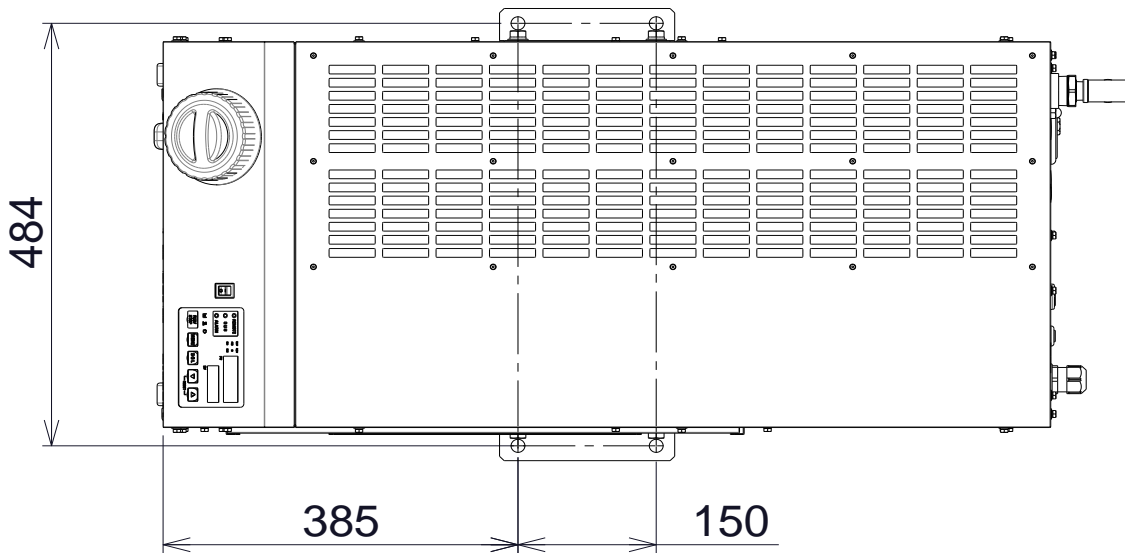

Fig. 9-2 Dimensions for the positions of the anchor bolts

### 9.3.2 HRLE050-W-20-\*

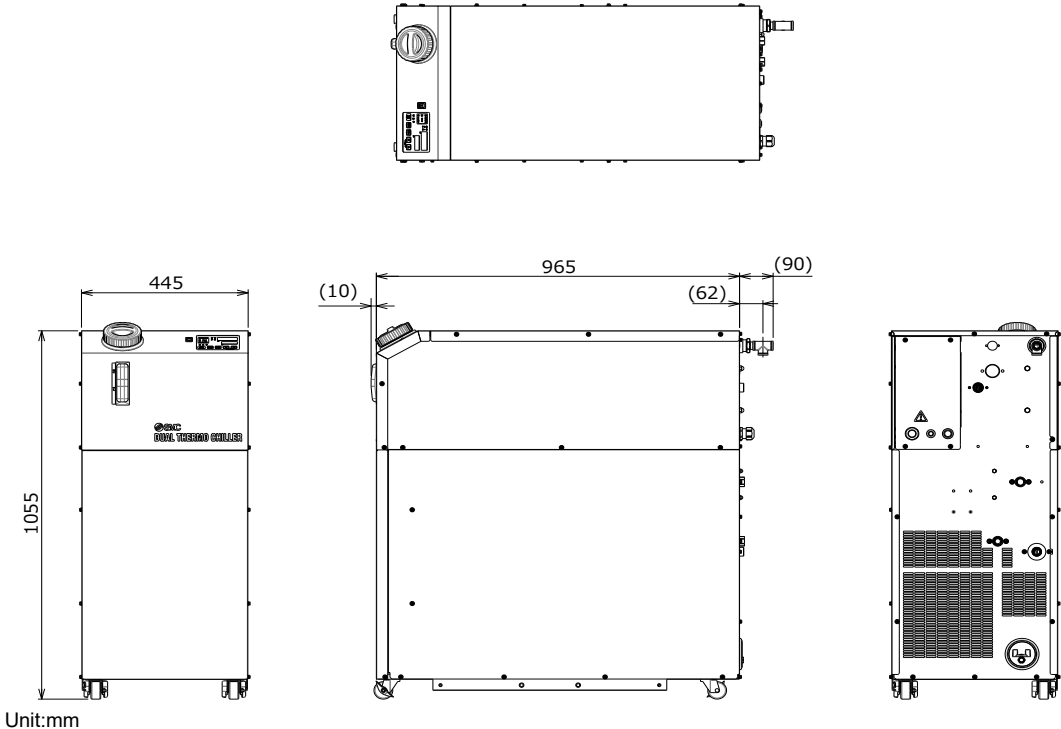

Fig. 9-3 Dimensions

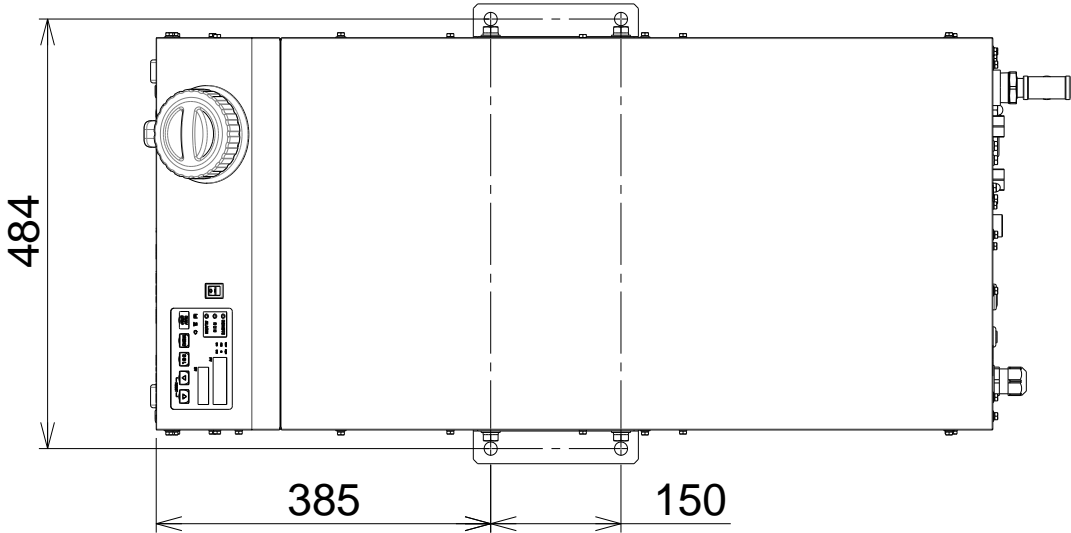

Fig. 9-4 Dimensions for the positions of the anchor bolts

### 9.3.3 HRLE090-A-20/40-\*

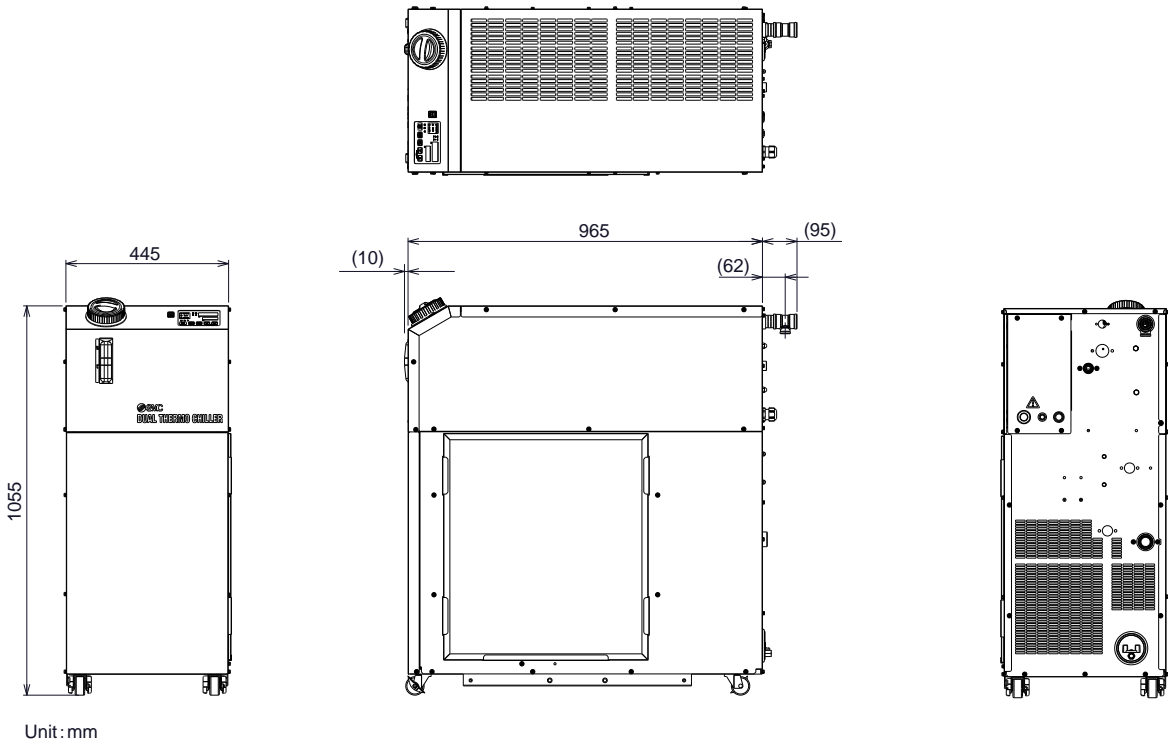

Fig. 9-5 Dimensions

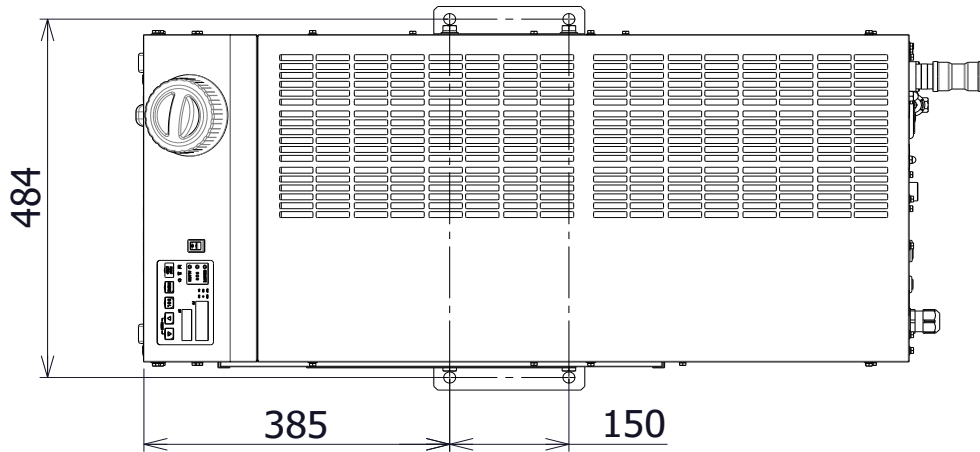

Fig. 9-6 Dimensions for the positions of the anchor bolts



### 9.3.4 HRLE090-W-20/40-\*

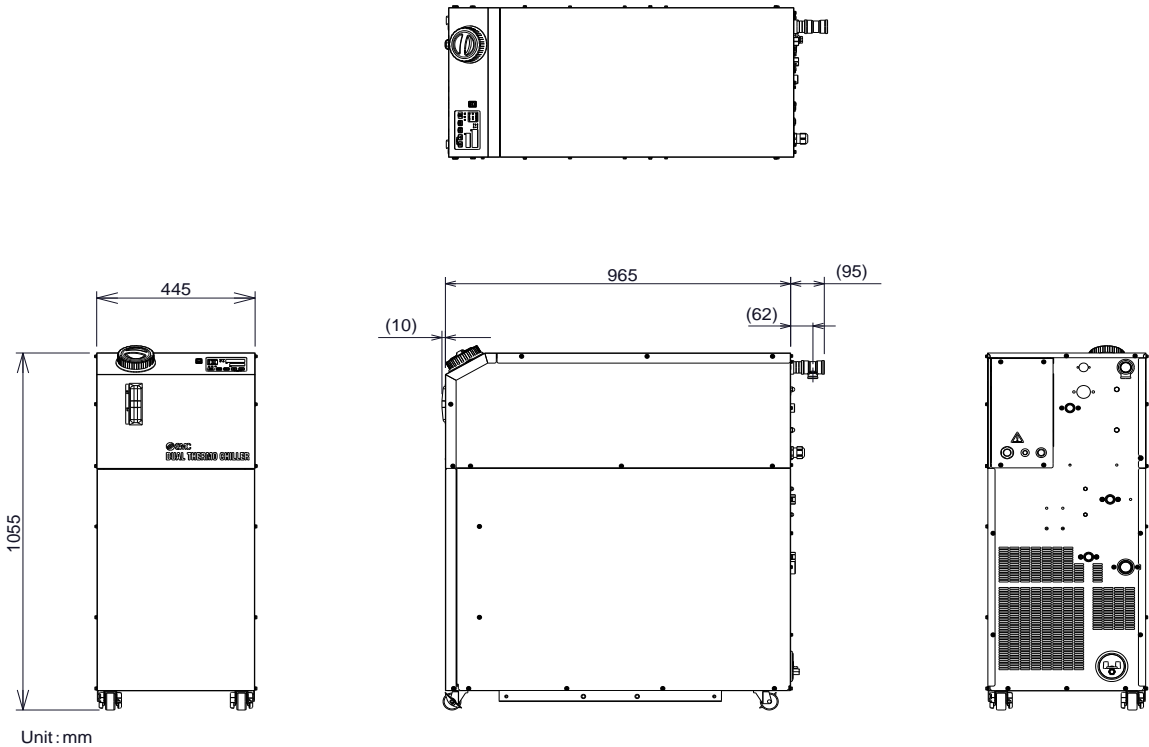

Fig. 9-7 Dimensions

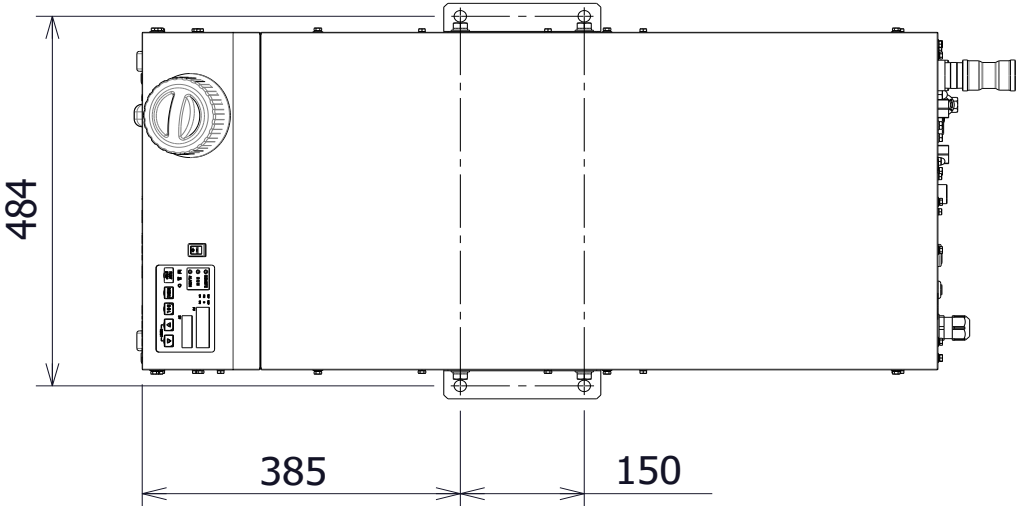

Fig. 9-8 Dimensions for the positions of the anchor bolts

## 9.4 Flow Diagram

### 9.4.1 HRLE050-A-20-\*,HRLE090-A-20/40-\*

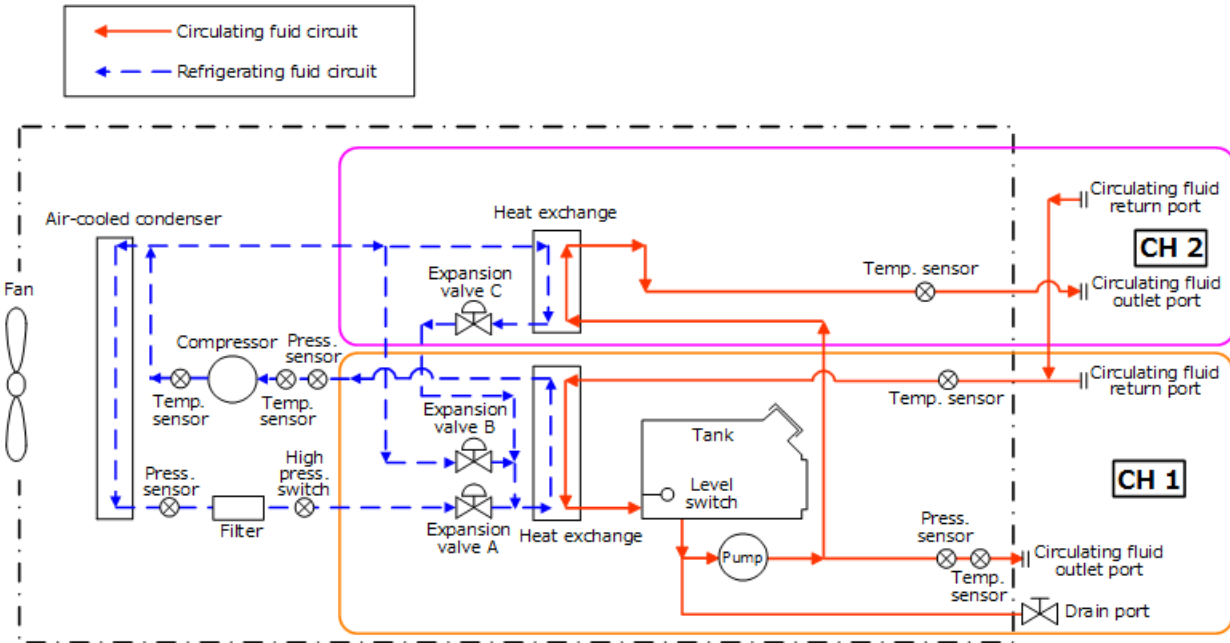

Fig. 9-9 Flow Diagram (HRLE090-A-20/40-※)

### 9.4.2 HRLE050-W-20-\*,HRLE090-W-20/40-\*

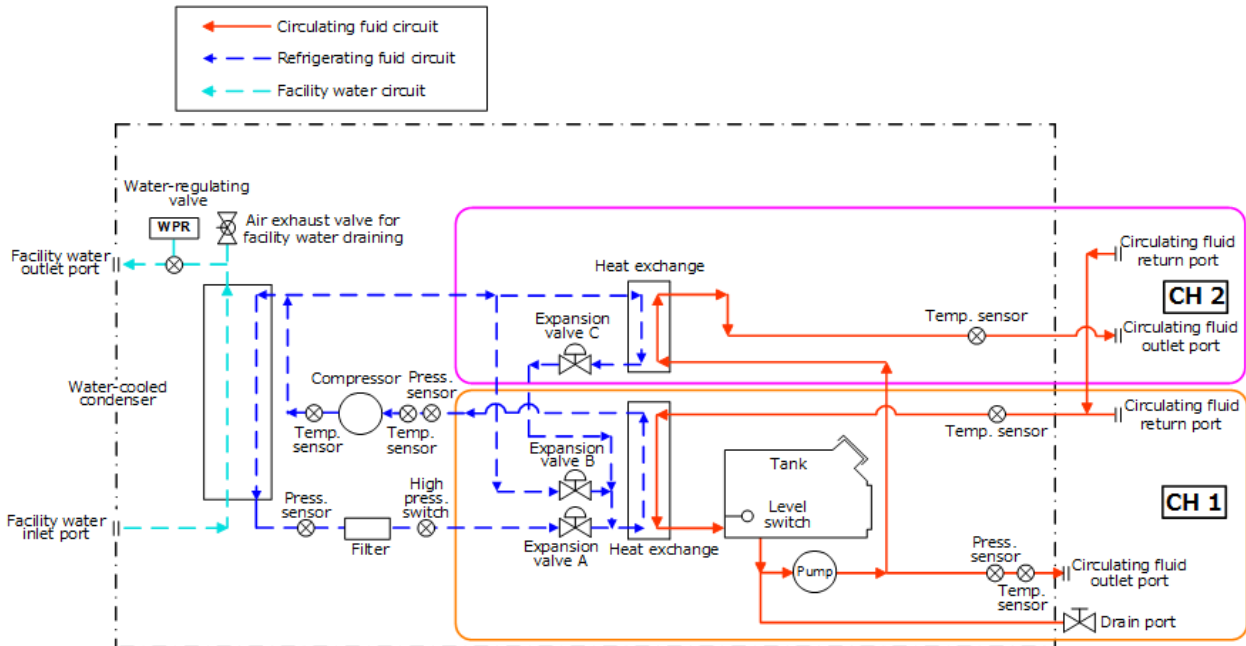

Fig. 9-10 Flow Diagram (HRLE090-W-20/40-※)

## 9.5 Cooling Capacity

### 9.5.1 HRLE050-A-20-\*

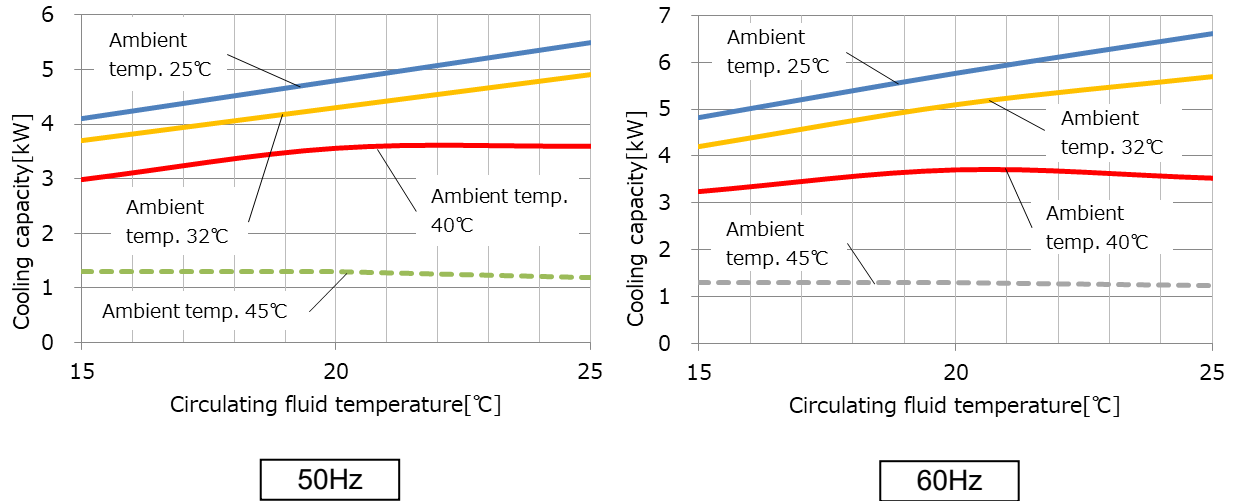

Fig. 9-11 Cooling Capacity

\* Cooling capacity is total of CH1 and CH2.

### 9.5.2 HRLE050-W-20-\*

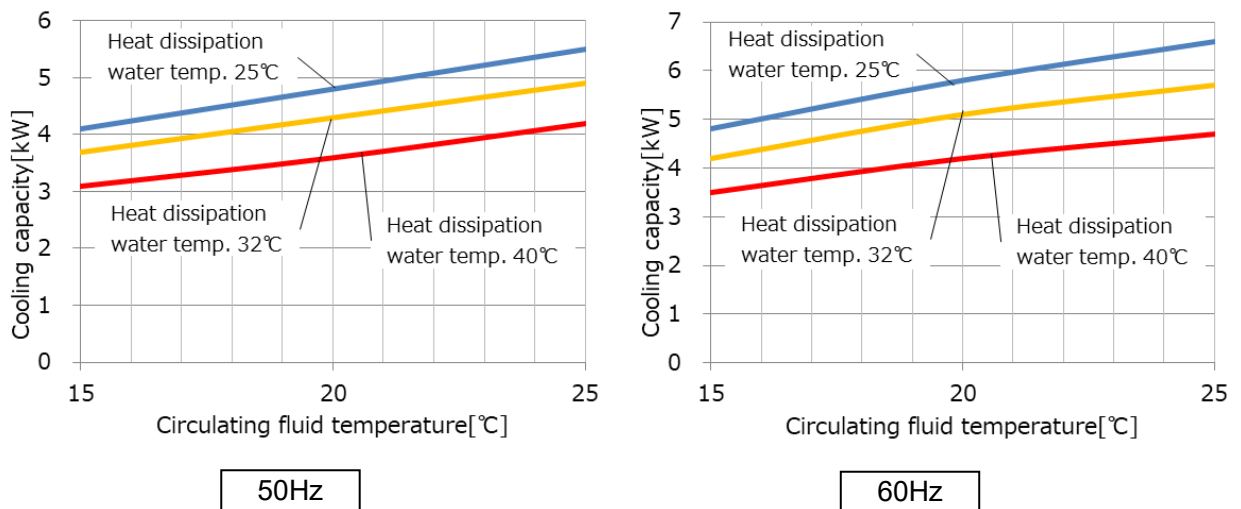

Fig. 9-12 Cooling Capacity

\* Cooling capacity is total of CH1 and CH2.

### 9.5.3 HRLE090-A-20/40-\*

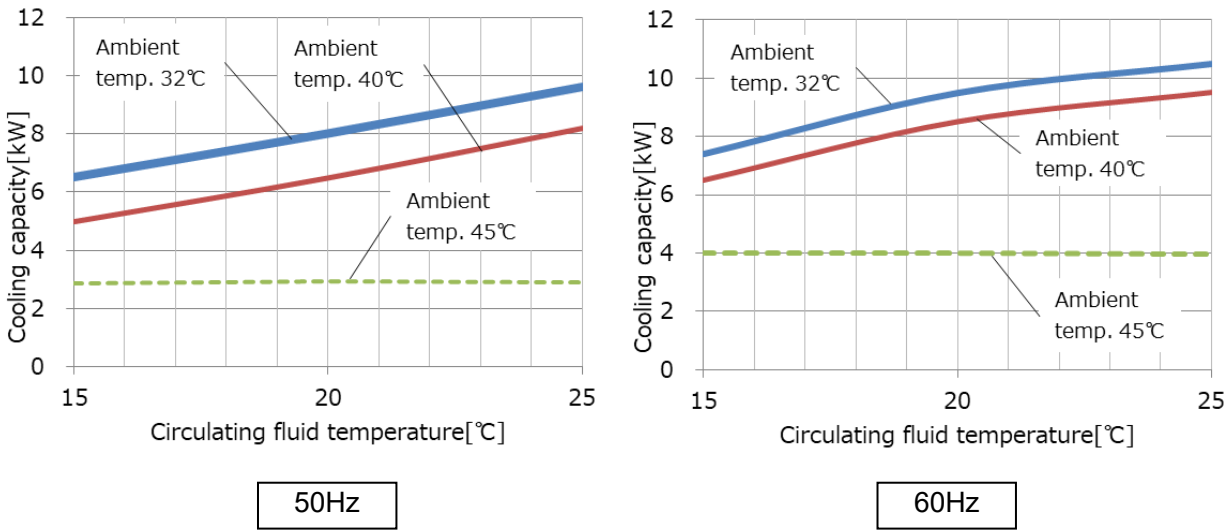

Fig. 9-13 Cooling Capacity

- \* Cooling capacity is total of CH1 and CH2.
- \* Cooling capacity at an ambient temperature of 32 °C is the value when the fan output is 60% (default setting).
- \* Cooling capacity at an ambient temperature of 40/45 °C is the value when the fan output is 100%.  
 (The noise increases by about 3 dB(A) from the rated conditions.)
- \* If you select option C, it is possible to power up the cooling capacity to the same capacity as the 60Hz area even in the 50Hz area.

### 9.5.4 HRLE090-W-20/40-\*

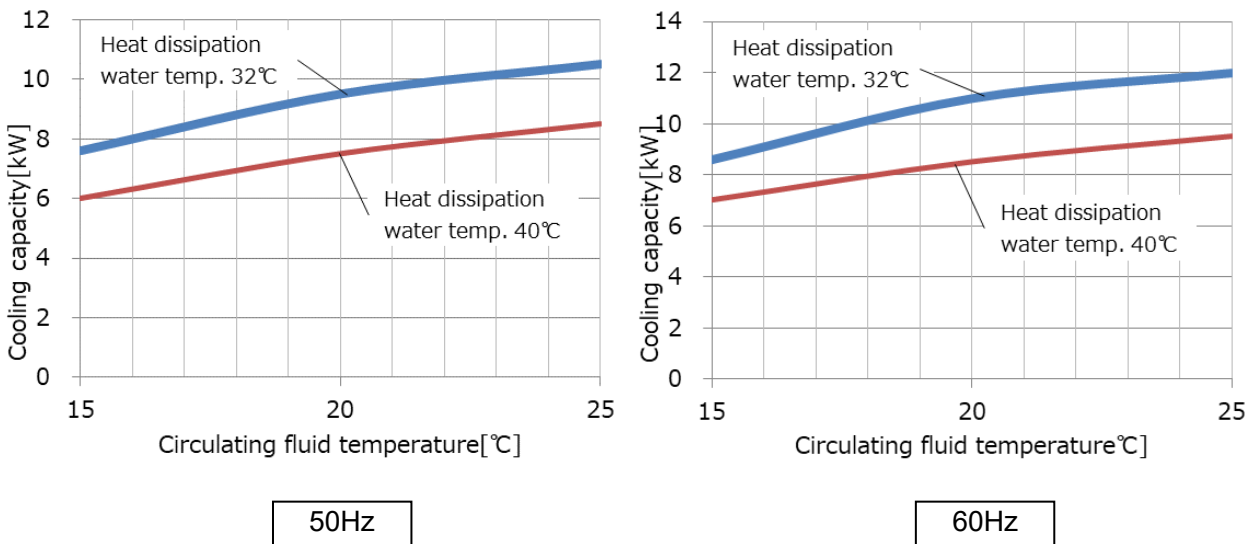
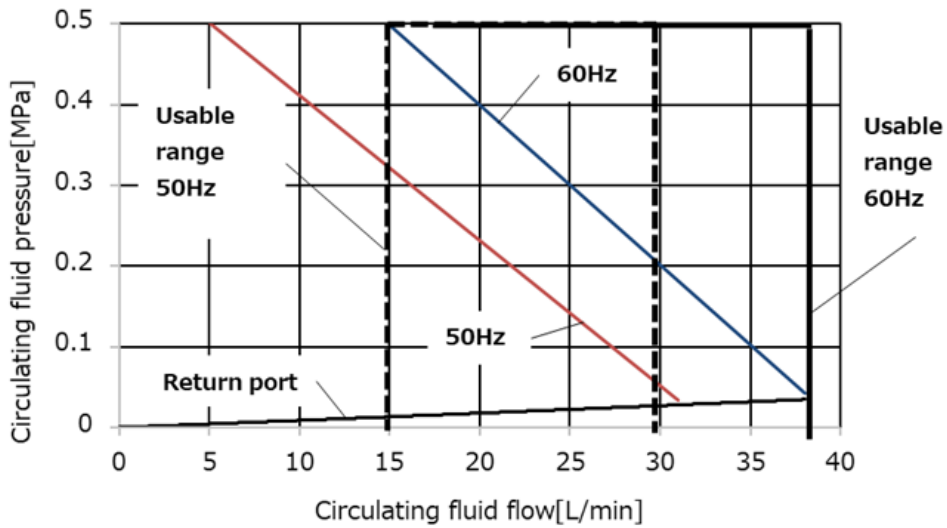

Fig. 9-14 Cooling Capacity

- \* If you select option C, it is possible to power up the cooling capacity to the same capacity as the 60Hz area even in the 50Hz area.

## 9.6 Pump Capacity

Model No. : HRLE050- ※ -20



\* This pump capacity is flow rate of CH1 when flow rate of CH2 is 2L/min.

Fig. 9-15 Pump capacity diagram

Model No. : HRLE090- ※ -20/40

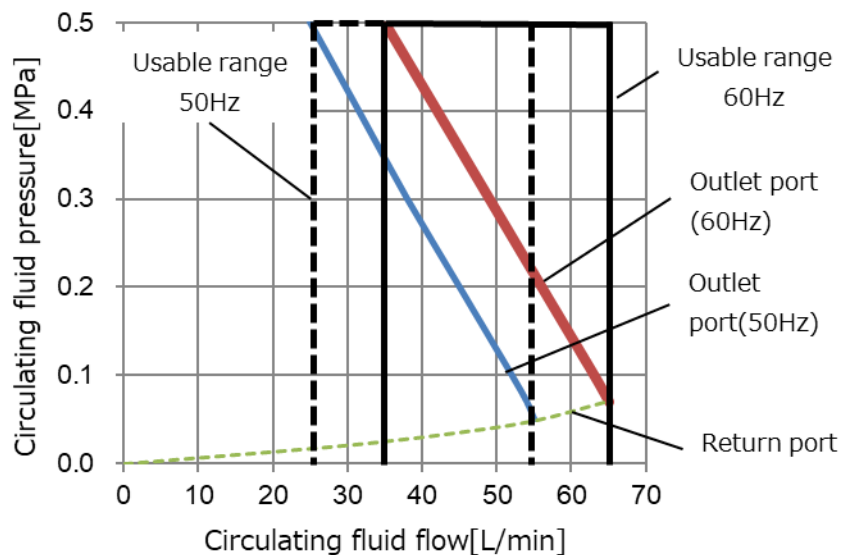

\* This pump capacity is flow rate of CH1 when flow rate of CH2 is 2L/min.

Fig. 9-16 Pump capacity diagram (standard product)

**Model No. : HRLE090- ※ -20/40-P**

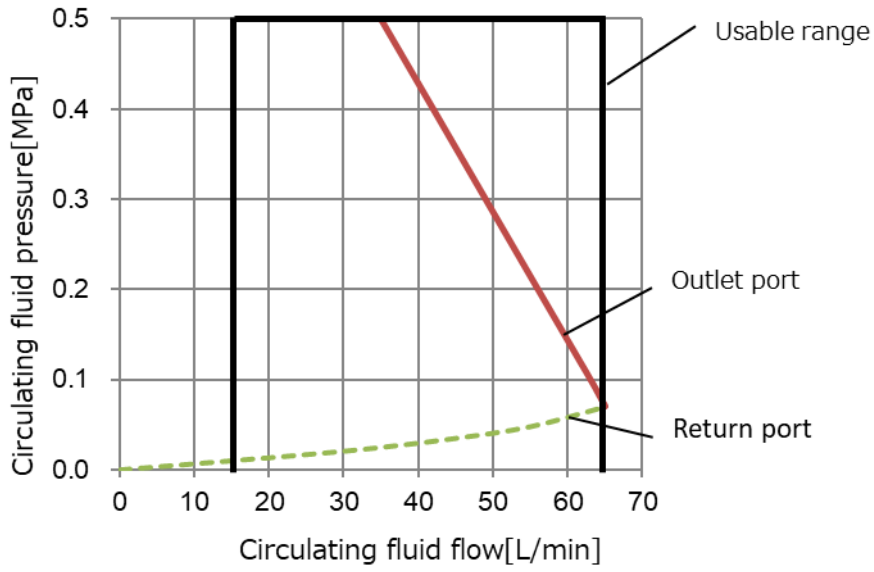

\* This pump capacity is flow rate of CH1 when flow rate of CH2 is 2L/min.

Fig. 9-17 Pump capacity diagram (Option P)

## 9.7 Heating capacity

**Model No. : HRLE050-A-20**

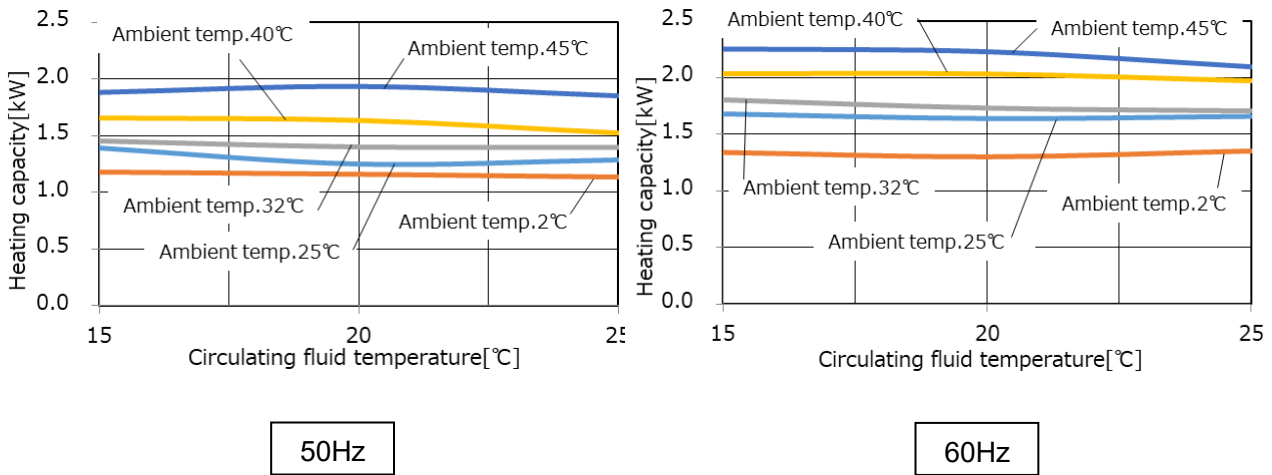

Fig. 9-18 Heating capacity(HRLE050-A-20)

**Model No. : HRLE050-W-20**

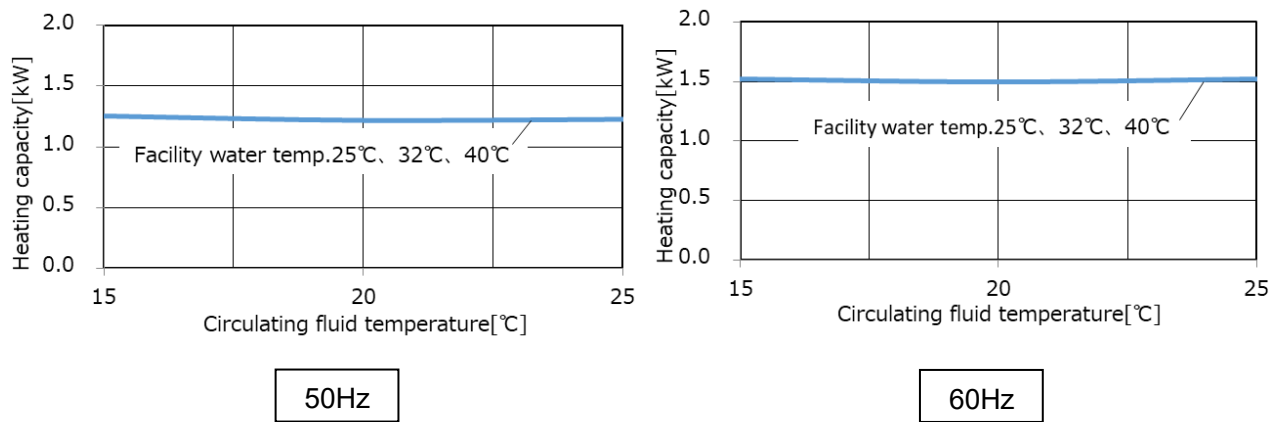

Fig. 9-19 Heating capacity(HRLE050-W-20)

**Model No. : HRLE090-A/W-\***

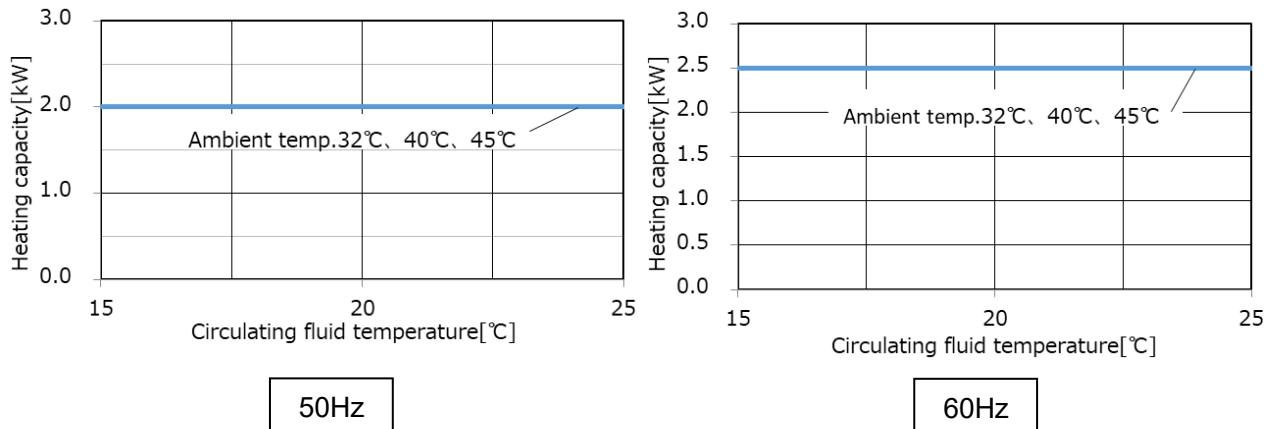
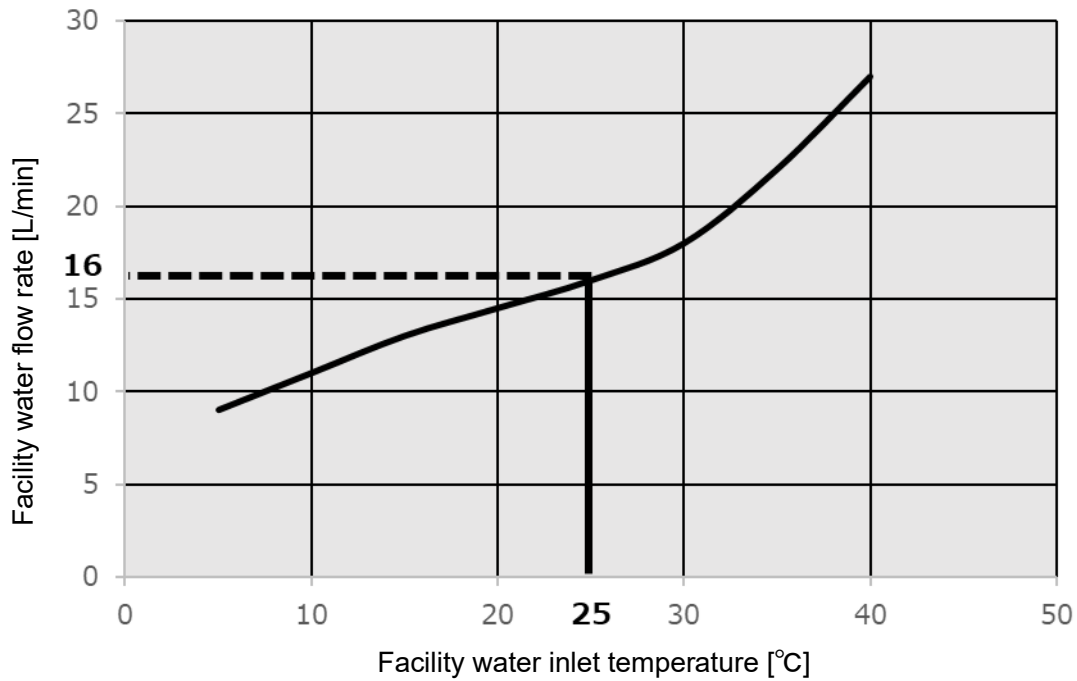

Fig. 9-20 Heating capacity(HRLE090-A/W-\*)

## 9.8 Required facility water flow

Model No.: HRLE050- W -20



This is the rated flow rate of the circulating fluid and the flow rate of radiated water required for the cooling capacity specifications shown in Fig. 9-14.

Fig. 9-21 Required facility water flow



## 9.9 Sample DoC.



Original declaration Doc. No. HRLE -TF1Z055UK

### UK DECLARATION OF CONFORMITY

**SMC Corporation**, 4-14-1, Sotokanda, Chiyoda-ku, Tokyo 101-0021, JAPAN, declares under its sole responsibility, that the following equipment:

**Thermo Chiller**

**HRLE Series**

**Serial No. ZT001 onwards Marked H**

is in conformity with relevant statutory regulations (including amendments) and has been demonstrated to fulfil the requirements with reference to the designated standards as listed below:

Statutory Instrument	Requirements	Designated Standards
Supply of Machinery (Safety) Regulations 2008	Schedule 2	EN ISO 12100:2010 EN 60204-1:2018
Electromagnetic Compatibility Regulations 2016	Schedule 1	EN 61000-6-2:2005 EN 61000-6-4:2007+A1:2011
The Restriction of the Use of Certain Hazardous Substances in Electrical and Electronic Equipment Regulations 2012	Schedule 2	EN IEC 63000:2018

The person authorised to compile the technical file is the person named at the address below:

Importer/Distributor contact details:



Vincent Avenue  
Milton Keynes  
MK8 0AN

[www.smc.eu](http://www.smc.eu), [www.smcworld.com](http://www.smcworld.com)

Tokyo, Date: \*\* Jun. 2021

\_\_\_\_\_  
Mitsuhiro Watanabe  
General Manager  
Product Development Division - 6  
4-2-2, Kinunodai, Tsukubamirai-shi,  
Ibaraki 300-2436, JAPAN



Original declaration Doc. No. HRLE - TF1Z055EU

## EU DECLARATION OF CONFORMITY

EC Декларация за съответствие	EU-vaatimusten mukaisuusvakuutus	EU-coformiteitsverklaring
EU Prohlášení o shodě	Déclaration UE de conformité	Deklaracja zgodności UE
EU-overensstemmelseserklæring	EU izjava o skladnosti	Declaração UE de conformidade
EU-Konformitätserklärung	EU-megfelelőségi nyilatkozat	Declarația de conformitate ue
Δήλωση συμμόρφωσης ΕΕ	Dichiarazione UE di conformità	Vyhlasenie o zhode EÚ
Declaración UE de conformidad	ES atitikties deklaracija	Izjava EU o skladnosti
ELi vastavusdeklaratsioon	ES atbilstības deklarācija	EU-försäkran om överensstämmelse

**SMC Corporation**, 4-14-1, Sotokanda, Chiyoda-ku, Tokyo 101-0021, JAPAN, declares under its sole responsibility, that the following equipment:

### Thermo Chiller

### HRLE Series

### Serial No. ZT001 onwards Marked H

is in conformity with the relevant Union harmonisation legislation and has been demonstrated to fulfil the requirements with reference to the harmonised standard(s) or applied standard(s) as listed below:

Directive	Requirements	Harmonised/applied standards
2006/42/EC [Machinery Directive]	Annex I	EN ISO 12100:2010 EN 60204-1:2018
2014/30/EU [EMC Directive]	Annex I	EN 61000-6-2:2005 EN 61000-6-4:2007+A1:2011
2011/65/EU <sup>(1)</sup> [RoHS Directive]	Annex II	EN IEC 63000:2018

<sup>(1)</sup> Including substances added by Commission Delegated Directive (EU) 2015/863.

Name and address of the person authorised to compile the technical file<sup>(2)</sup>:

Mr. G. Berakoetxea, Executive Officer, SMC European Zone,  
SMC España, S.A., Zuazobidea 14, 01015 Vitoria, Spain

Importer/Distributor contact details [www.SMC.eu](http://www.SMC.eu), [www.SMCworld.com](http://www.SMCworld.com)

Tokyo, Date: \*\* Jun.2021

Mitsuhiro Watanabe  
General Manager  
Product Development Division - 6

# 9.10 Standards

This product complies with the standards shown below.

Table 9-8 Standards

Standard	CE marking
	UKCA marking

 **Thermo-chiller Daily Check Sheet**

For how to check the daily inspection items of the thermo-chiller, refer to "Table 8-2 Daily check items" in "8.2.1 Daily inspection" of "Chapter 8 Model No. \_\_\_\_\_  
 Control, Inspection and Cleaning".  
 Be sure to enter the state at the start of operation immediately after installation. Serial No. \_\_\_\_\_

Date	Checked by	Installation conditions		Fluid leakage	Amount of fluid		Operation panel		Discharge temperature		Return temperature	Discharge pressure	Electric conductivity	Compressor inlet temperature	Refrigerant		Operating conditions		Result		
		Temperature	Humidity		Liquid level gauge display range	Inside/outside	Display	Operation	CH1	CH2					High pressure	Low pressure	Abnormal	Yes / No			
		°C	%	Yes / No					°C	°C	°C	MPa	Ms / cm	°C	MPa	MPa	Yes / No				
Immediately after installation (initial Value)																					

# Chapter 10 Limited warranty and Disclaimer/ Compliance Requirements

The product used is subject to the following "Limited warranty and Disclaimer" and "Compliance Requirements". Read and accept them before using the product.

## 1. Period of warranty

The warranty period of the product is 1 year in service or within 1.5 years after the product is delivered, whichever is earlier.

## 2. Scope of Warranty

For any failure reported within the warranty period which is clearly our responsibility, replacement parts will be provided.

The product or part that is replaced with a replacement will become SMC's property.

This warranty applies only to our product independently, and not to any other damage incurred due to the failure of the product.

## 3. Content of Warranty

1. We guarantee that the product will operate normally if it is installed in accordance with the Operation Manual by qualified personnel, and operated under the conditions specified in the catalog or contracted separately.
2. We guarantee that the product does not have any defects in components, materials or assembly.
3. We guarantee that the product complies with the outline dimensions provided.
4. The following cases are not covered by warranty.
  - ① The product has been improperly mounted or improperly connected to other machines.
  - ② The product was under insufficient maintenance and control or was incorrectly handled.
  - ③ The product was operated outside of the specifications.
  - ④ Modification or alteration of the structure of the product by the user.
  - ⑤ The failure was a secondary failure of the product caused by the failure of equipment connected to the product.
  - ⑥ Failure was caused by a natural disaster such as an earthquake, typhoon, flood damage, lightning, or fire.
  - ⑦ The failure was caused by operation different from that shown in the Operation Manual or exceeding the specification ranges.
  - ⑧ The checks and maintenance specified (daily checks and regular checks) were not performed.
  - ⑨ The failure was caused by the use of circulating fluid or facility water other than those specified.
  - ⑩ The failure occurred naturally over time (such as discoloration of a painted or plated face).
  - ⑪ The failure does not affect the ability of the product to function (such as new sounds, noises and vibrations).
  - ⑫ The failure was due to a failure to use the product in the environment specified in "Installation Environment" in the Operation Manual.
  - ⑬ The failure was caused by the customer disregarding "6. Request to customers".

## 4. Agreement

If there is any doubt about anything specified in the "2. Scope of Warranty" and "3. Content of Warranty", it shall be resolved by agreement between the customer and SMC.

## 5. Disclaimer

- ① Expenses for daily and regular checks
- ② Expenses for repairs performed by other companies
- ③ Expenses for transfer, installation and removal of the product
- ④ Expenses for replacement of parts other than those in this product, or for the supply of liquids
- ⑤ Inconvenience and loss due to product failure  
(such as telephone bills, compensation for workplace closure, and commercial losses)
- ⑥ Expenses and compensation not covered in "2. Scope of Warranty"

**6. Request to customers**

Proper use and maintenance are essential to assure safe use of this product. Be sure to satisfy the following preconditions. Please note that we may refuse to carry out warranted repair if these preconditions have been disregarded.

- (1) Use the product following the instructions for handling described in the Operation Manual.
- (2) Perform checks and maintenance (daily checks and regular checks) specified in the Operation Manual and Maintenance Manual.
- (3) Record the check results on the daily check sheet specified in the Operation Manual.

**7. Request for Warranted Repair**

For warranted repair, please contact the supplier you purchased this product from. Warranted repair shall be on a request basis.

Repair shall be provided free of charge in accordance with the warranty period, preconditions and terms defined above. Therefore, a fee will be charged for repairs of failures after the end of the warranty period.

**『Compliance Requirements』**

The use of SMC products with production equipment for the manufacture of weapons of mass destruction (WMD) or any other weapon is strictly prohibited. The exports of SMC products or technology from one country to another are governed by the relevant security laws and regulations of the countries involved in the transaction. Prior to the shipment of a SMC product to another country, assure that all local rules governing that export are known and followed.



Revision history
Rev.1 : Jul 2024

# SMC Corporation

Tel: + 81 3 5207 8249 Fax: +81 3 5298 5362

URL <https://www.smcworld.com>

---

Note: Specifications are subject to change without prior notice and any obligation on the part of the manufacturer.  
© SMC Corporation All Rights Reserved