



Operation Manual

Chemical Thermo-con

Model No.

HED003-W2^A_B¹³₁₉

HED003-C2^A_B (Temperature Controller)

HED003-HW¹³₁₉ (Heat Exchanger)

HED005-W2^A_B¹³₁₉

HED005-C2^A_B (Temperature Controller)

HED005-HW¹³₁₉ (Heat Exchanger)

HED007-W2^A_B¹³₁₉

HED007-C2^A_B (Temperature Controller)

HED007-HW¹³₁₉ (Heat Exchanger)

HED009-W2^A_B25

HED009-C2^A_B (Temperature Controller)

HED009-HW25 (Heat Exchanger)

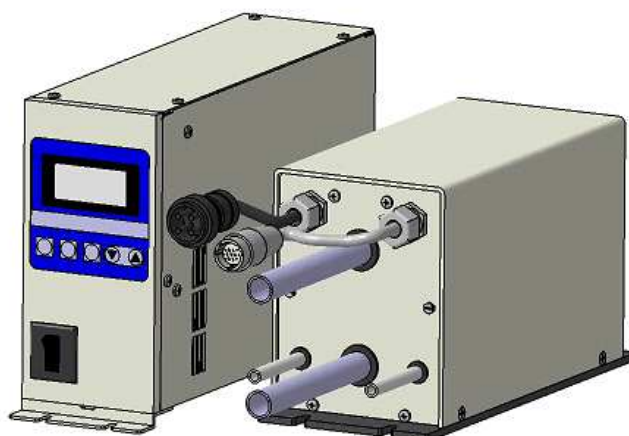

Keep this manual available whenever necessary.

Copying, duplicating or transferring any part or the entirety of this manual without the prior permission of SMC is strictly prohibited.

Preface

Thank you very much for purchasing SMC Chemical Thermo-con HED Series.

This manual is described for operation of this unit. Please use this manual for efficient and long use of this unit. Be sure to read this manual efficiently for your deep understanding of overview and safety of this unit before installation or carrying out the relevant operations of this unit. Especially, you need to follow the instructions about "Danger", "Warning" and "Caution".

Packaged items

Upon receipt of the ordered product, immediately check that the following components have been included.

Packaging content		
	Item	Qty.
1	Temperature Controller	1 pc
2	Heat Exchanger	1 pc
3	Power supply cable	1 pc
4	Operation Manual	1 pc

Warning and Precautions on Handling

- 1) Be sure to read this Warning and Precautions on Handling carefully.
- 2) This manual provides explanations of the installation and operation of this product. Only those who have a thorough understanding of the operating procedures and who have basic knowledge and skills in handling industrial equipment are qualified to perform installation and operation.
- 3) The contents of this manual and the related documents supplied with this product shall be neither regarded as a provision of the contract nor utilized to correct or modify the existing agreements, commitments and relations.
- 4) Copying, duplicating or transferring any part or the entirety of this manual without the prior permission of SMC is strictly prohibited.
- 5) This product has been developed for physical, chemical, and industrial facility applications. When it is used for applications that require the consideration additional safety precautions, e.g., for medical devices, investigate the safety needs for the application at the customer's site before use.

Note: The contents of this manual are subject to change without notice.

Contents

Chapter 1 Safety Instructions	1-1
1.1 Before using the Chemical Thermo-con	1-1
1.2 Safety training	1-1
1.3 Hazard Levels	1-2
1.3.1 Definitions of "Serious injury" and "Minor injury"	1-3
1.3.2 Symbols	1-3
1.4 Hazard Warning Labels	1-5
1.4.1 Location of hazard warning labels	1-6
1.5 Safety Measures	1-14
1.5.1 Precautions	1-14
1.5.2 Protective Equipment	1-15
1.5.3 Long-term Storage	1-16
1.5.4 Disposing of Product	1-16
1.5.5 Safety Interlock	1-16
Chapter 2 Description and Function of Each Part	2-1
2.1 Temperature Controller	2-1
2.2 Heat Exchanger	2-2
Chapter 3 Composition and Function of Product	3-1
3.1 Composition	3-1
3.1.1 Outline	3-1
3.2 Function	3-2
3.2.1 Auto tuning function	3-2
3.2.2 Off-set function	3-2
3.2.3 Learning control function	3-2
3.2.4 External sensor control function	3-3
3.2.5 Temperature sensor fine control function	3-3
3.2.6 Memorization of Set values function (Function that backs up with EEPROM)	3-3
3.2.7 Temperature Upper / Lower Limit Alarm Function	3-4
3.2.8 Communication Function	3-4
3.2.9 Remote ON/OFF function	3-5
3.2.10 Output cutoff Alarm Function	3-6
Chapter 4 Installation	4-1
4.1 Installation, Transport and Transfer	4-1
4.1.1 Transport and Transfer	4-1
4.1.2 Environment	4-1
4.1.3 Set-up in Clean Room	4-2
4.1.4 Installation	4-2
4.2 Piping	4-3
4.2.1 Preparation of Facility Water	4-4
4.2.2 Preparation of Recirculating Fluid	4-5

4.2.3	Purge	4-6
4.3	Wiring.....	4-7
4.3.1	Circuit Breaker (Ground Fault Circuit Interrupters).....	4-7
4.3.2	Power Supply.....	4-8
4.3.3	Grounding	4-8
4.3.4	Avoidance of Parallel Wiring.....	4-9
4.3.5	Incorrect Wiring.....	4-9
4.3.6	Prevention of electrostatic discharge.....	4-9
4.3.7	Removal of Cables	4-9
4.3.8	Connection of Various Types of Connectors and Power Supply Plugs	4-9
4.4	Installation.....	4-10
Chapter 5 Operation		5-1
5.1	Start of Operation	5-1
5.2	Setting of Values.....	5-1
5.3	Cautions for Operation Control.....	5-2
5.3.1	Indication and Setting when Output Cutoff Alarm Operates.....	5-2
5.4	Operation of Controller	5-3
5.4.1	Details of Operation and Display Panel.....	5-3
5.5	How to operate.....	5-4
5.5.1	Setting Mode, Level 1	5-5
5.5.2	Detail of setting mode level 1	5-6
5.5.3	Setting Mode, Level 2.....	5-9
5.5.4	Detail of setting mode level 2	5-10
5.5.5	Setting Mode, Level 3.....	5-13
5.5.6	Detail of setting mode level 3	5-13
Chapter 6 Alarms		6-1
6.1	How to Identify Alarm	6-1
6.2	Alarm indication.....	6-2
6.3	Content of Alarms.....	6-3
6.4	Troubleshooting.....	6-5
Chapter 7 Communication		7-1
7.1	Preparation for Communication.....	7-1
7.2	Specifications of communication method.....	7-2
7.3	Communication format.....	7-3
7.3.1	Control code used for communication	7-3
7.3.2	Command code list.....	7-3
7.3.3	Communication procedures and format	7-4
7.3.4	Calculation of Check Sum	7-6
7.4	Details of Communication Format	7-7
7.4.1	Setting of target temp. (without writing EEPROM)	7-7
7.4.2	Reading of target temp.	7-7
7.4.3	Reading of current temp. with internal sensor.....	7-8
7.4.4	Reading of current temp. with external sensor.....	7-8

7.4.5	Reading of alarm status	7-9
7.4.6	Reading of temp. average data.....	7-10
7.4.7	Setting of offset value (without writing EEPROM).....	7-11
7.4.8	Reading of offset value.....	7-11
7.4.9	Setting of control operation mode (without writing EEPROM)	7-12
7.4.10	Reading of control operation mode	7-12
7.4.11	Setting of PB range (without writing EEPROM)	7-13
7.4.12	Reading of PB range.....	7-13
7.4.13	Setting of ARW range (without writing EEPROM).....	7-14
7.4.14	Reading of ARW range.....	7-14
7.4.15	Setting of I constant (without writing EEPROM)	7-15
7.4.16	Reading of I constant	7-15
7.4.17	Setting of D constant (without writing EEPROM).....	7-16
7.4.18	Reading of D constant.....	7-16
7.4.19	Reading of output ratio	7-17
7.4.20	Setting of heating power upper limit value (without writing EEPROM)	7-18
7.4.21	Reading of heating power upper limit value.....	7-18
7.4.22	Setting of cooling power upper limit value (without writing EEPROM)	7-19
7.4.23	Reading of cooling power upper limit value	7-19
7.4.24	Saving of set values (Transfer of all data from RAM to EEPROM).....	7-20
Chapter 8 Check • Repair		8-1
8.1	Daily check	8-1
8.2	Check after seismic vibration and impact	8-1
8.3	Repair and maintenance	8-2
8.3.1	Heat Exchanger.....	8-2
8.3.2	Temperature Controller.....	8-2
Chapter 9 Appendix		9-1
9.1	How to order and manufacturing code indication	9-1
9.1.1	How to order	9-1
9.1.2	Manufacturing code indication	9-2
9.2	Specifications.....	9-3
9.2.1	Specification table	9-3
9.3	Outline Dimensions	9-5
9.3.1	HED003-C2* Temperature Controller.....	9-5
9.3.2	HED003-HW* Heat Exchanger	9-6
9.3.3	HED005-C2* Temperature Controller.....	9-7
9.3.4	HED005-HW* Heat Exchanger	9-8
9.3.5	HED007-C2* Temperature Controller.....	9-9
9.3.6	HED007-HW* Heat Exchanger	9-10
9.3.7	HED009-C2* Temperature Controller.....	9-11
9.3.8	HED009-HW* Heat Exchanger	9-12
9.4	Specifications of Connectors	9-13
9.4.1	Connector.....	9-13

Contents

9.4.2	Power supply cable.....	9-15
9.5	Performance Chart.....	9-16
9.5.1	Performance of HED003.....	9-16
9.5.2	Performance of HED005.....	9-17
9.5.3	Performance of HED007.....	9-18
9.5.4	Performance of HED009.....	9-19
9.5.5	Recirculating fluid Pressure Loss	9-20
9.5.6	Facility water Pressure Loss.....	9-22
9.6	Applicable Fluids	9-23
9.7	Calculation of Dew Point Temperature (from psychrometric chart)	9-24
9.8	Conforming Standards/Laws	9-25
9.8.1	Safety Standards	9-25
9.8.2	Cautions for Export.....	9-25

Chapter 1 Safety Instructions



Be sure to thoroughly read and understand the important precautions defined in this manual before using this product.

1.1 Before using the Chemical Thermo-con

This chapter is dedicated for your safety during your relation with the unit. The Chemical Thermo-con is operated under high voltage.

Therefore, not only those who operate the unit, but those who are in charge of service work related to the unit and who work nearby the unit should read carefully and thoroughly understand descriptions related to safety in this manual before starting the work.

1.2 Safety training

This manual is not a general manual for safety and hygiene education that safety and hygiene tutors are supposed to conduct.

Anyone working with or near this unit is requested to be fully trained in aspect of recognition of the danger inherent to the unit and the safety countermeasures.

A manager is responsible for strict compliance to the safety standard in whole system, but individual person in charge of operation and maintenance should take responsibility for that accompanying the daily work and should care for the safety of its working location and environment.

Operators and maintenance responsible should secure the safety of workshops and their environment before work.

The work training concerning the unit should take place after the sufficient tutorage on safety. The training must not be carried without consideration to safety.

1.3 Hazard Levels

This product is designed with the safety of workers and the prevention of system damage as its first priority. This manual classifies the risks into the following three categories according to the severity and level of the hazard: Danger, Warning, and Caution. Read these statements carefully, and ensure that you thoroughly understand them before operating this product.

DANGER, WARNING and CAUTION signs follow this order according to hazard severity (DANGER > WARNING > CAUTION). See below for details.

DANGER

"DANGER" denotes that there is an imminent hazard which will cause serious personal injury or death during operation.

WARNING

"WARNING" denotes that there is a hazard which may cause serious personal injury or death during operation.

CAUTION

"CAUTION" denotes that there is a hazard which may cause minor personal injury during operation.

CAUTION

"CAUTION" without an exclamation point denotes that there is a hazard which may cause damage to or the failure of the system, facility, or devices.

[Tips]

Tips are provided when there is information and content that personnel are required to be aware of and refer to for product operation and maintenance of this product.

1.3.1 Definitions of “Serious injury” and “Minor injury”

■ “Serious injury”

This term describes injuries such as the loss of eyesight, wounds, burns, frostbite, electric shock, fractures, and toxicity that leave aftereffects, and/or injury requiring hospitalization and/or a prolonged stay in a hospital.

■ “Minor injury”

This term describes injuries that do not require hospitalization or a prolonged stay in a hospital (injuries other than the “serious injuries” described above).

1.3.2 Symbols

This manual provides the following symbols in addition to “Danger”, “Warning”, and “Caution” to present warning details in an easy-to-understand manner.

■ Symbol of electrical hazard

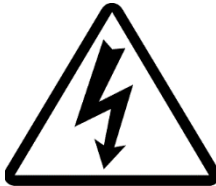

This symbol warns you of potential electrical shock.

■ Symbol of heat hazard



This symbol warns you of potential burns.

■ Symbol for corrosion



This symbol warns of chemical corrosion. When handling chemical fluids, read the SDS carefully and use appropriate protective equipment.

■ Symbol for inhalation



This symbol warns of chemical inhalation. When handling chemical fluids, read the SDS carefully and use appropriate protective equipment.

■ “Don’t” Symbol



This symbol denotes actions which you must not perform in the operation of this product.

■ “Do” Symbol









This symbol denotes actions which you must perform and items you must observe in the operation of this product.

1.4 Hazard Warning Labels

Hazard warning labels are applied to the sections of this system in which potential hazards are present during system operation and maintenance.

Hazard warning labels are presented in sizes and colors that will get the attention of the worker. They contain symbols in addition to the descriptions of warnings.

 WARNING	
	<ul style="list-style-type: none">• Do not peel off or deface the hazard warning labels.
 WARNING	
	<ul style="list-style-type: none">• Confirm the locations of the hazard warning labels.• Read the contents of the hazard warning labels carefully and keep them in mind.
 WARNING	
	<ul style="list-style-type: none">• Users are NOT allowed to change the locations of the hazard warning labels. If replacing a peeled off or worn out label, affix the new label to exactly the same location as the replaced label.

1.4.1 Location of hazard warning labels

■ HED003-C2^A_B (Temperature Controller)

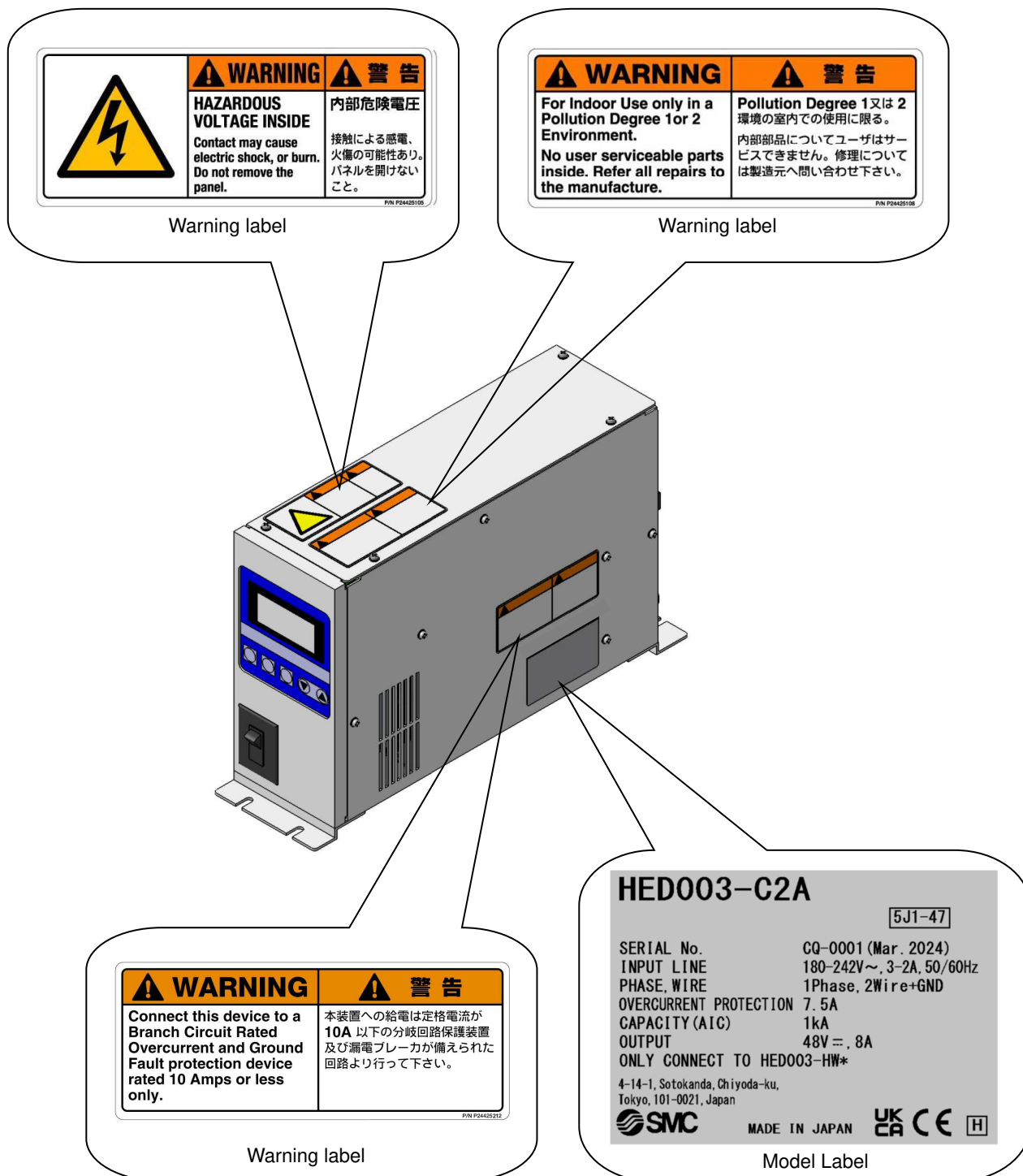

Fig. 1-1 Temperature controller

■ HED003-HW¹³₁₉ (Heat Exchanger)

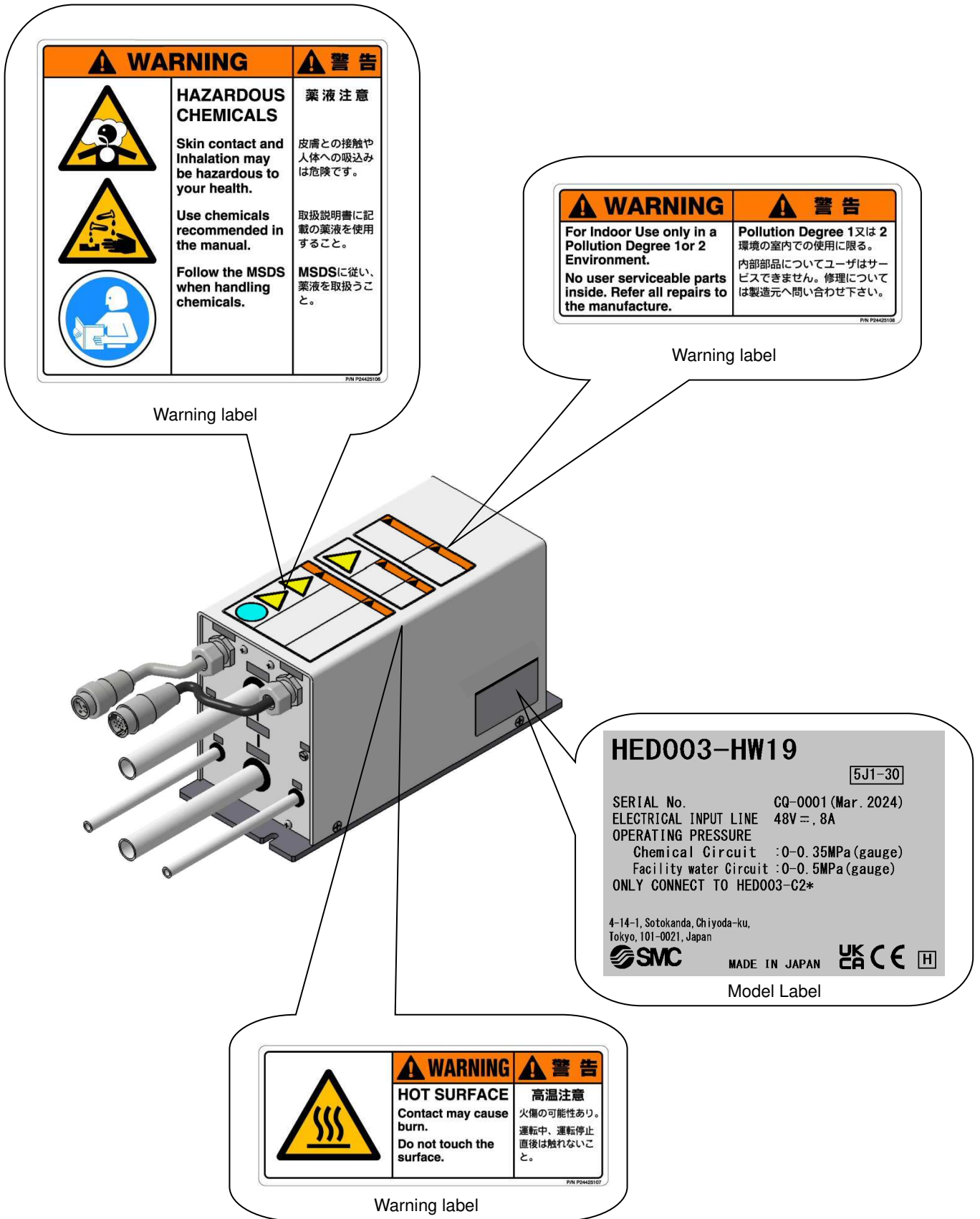

Fig. 1-2 Heat Exchanger

■ HED005-C2^A_B (Temperature Controller)

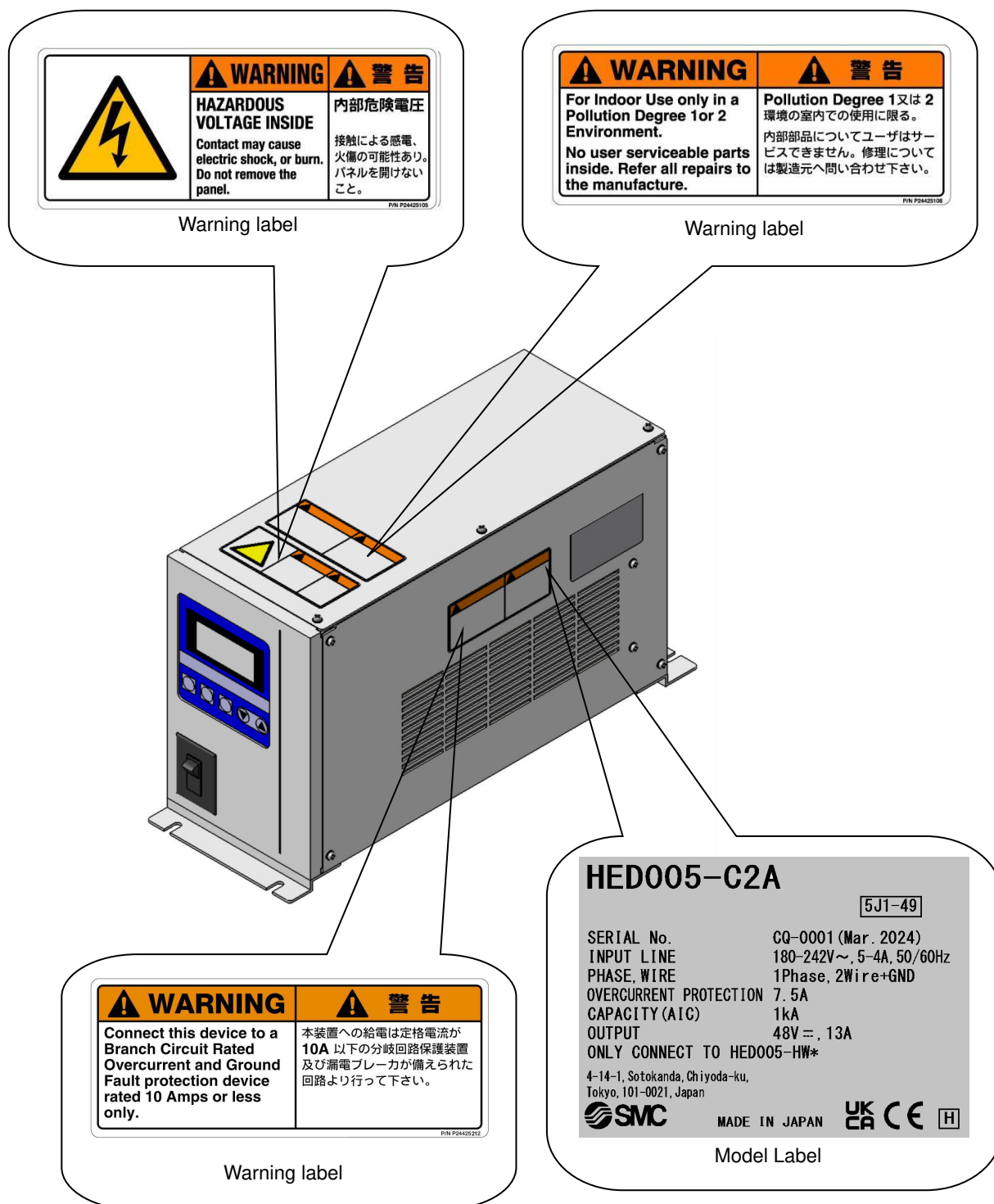

Fig. 1-3 Temperature controller

■ HED005-HW¹³₁₉ (Heat Exchanger)

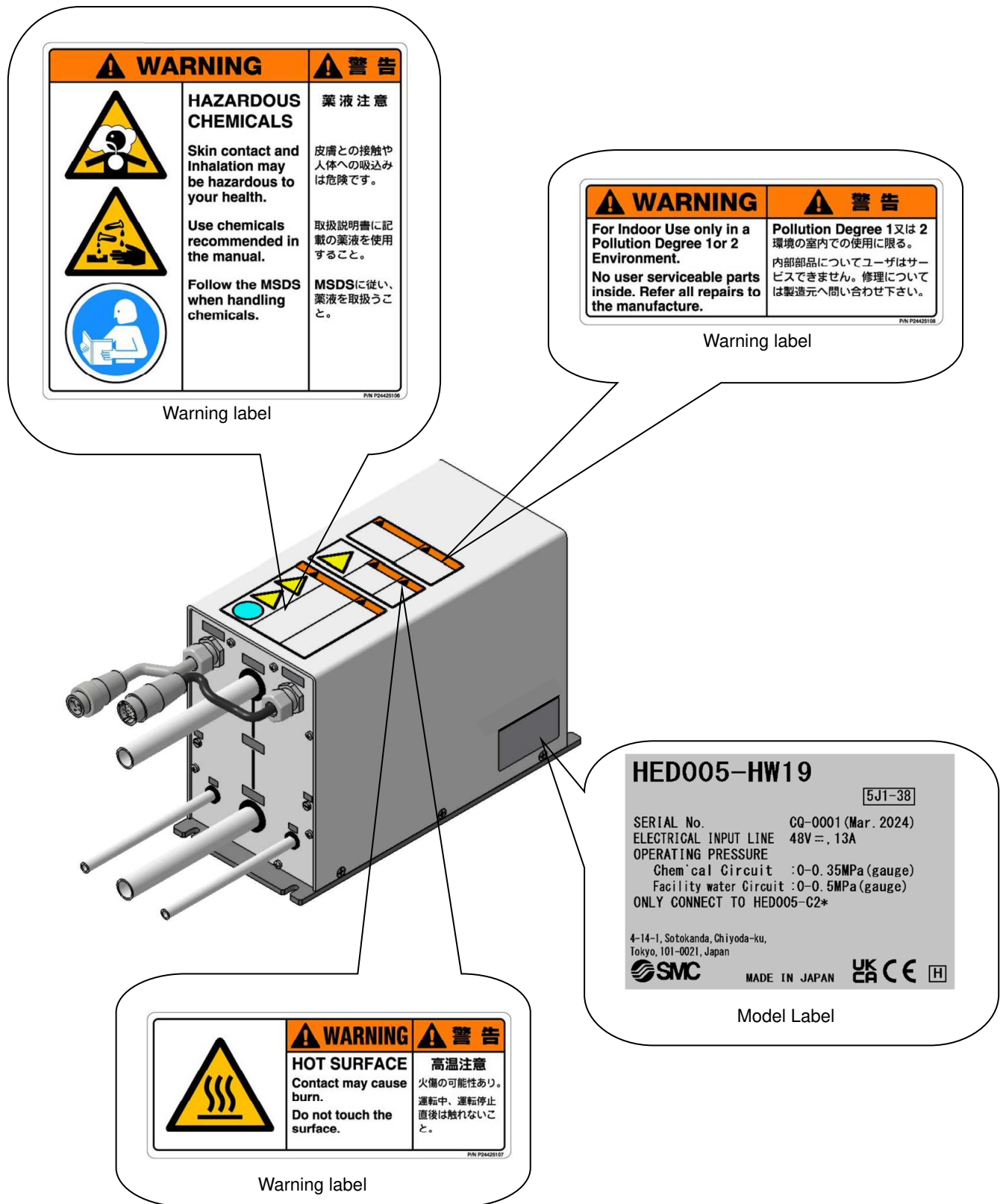

Fig. 1-4 Heat Exchanger

■ HED007-C2^A_B (Temperature Controller)

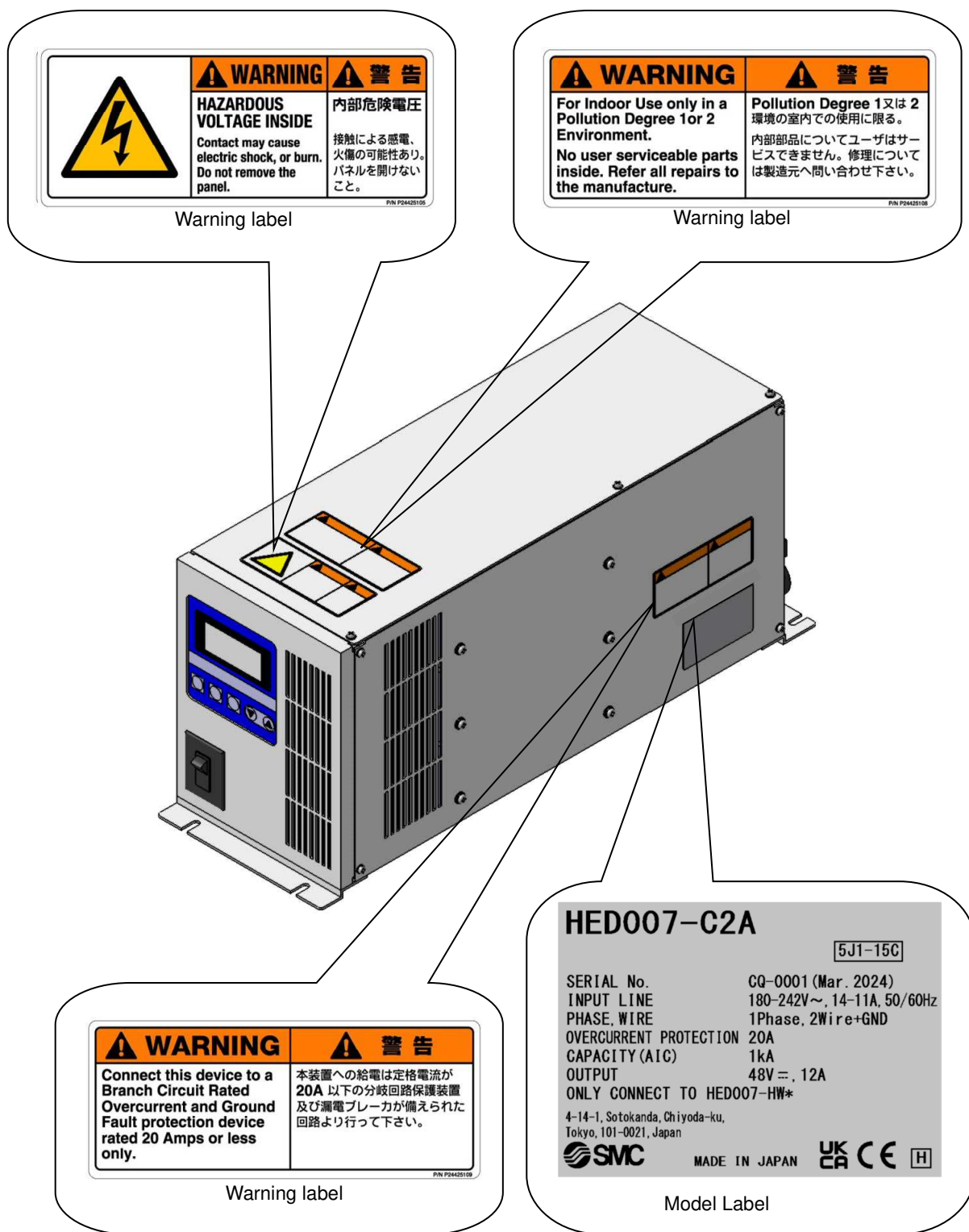
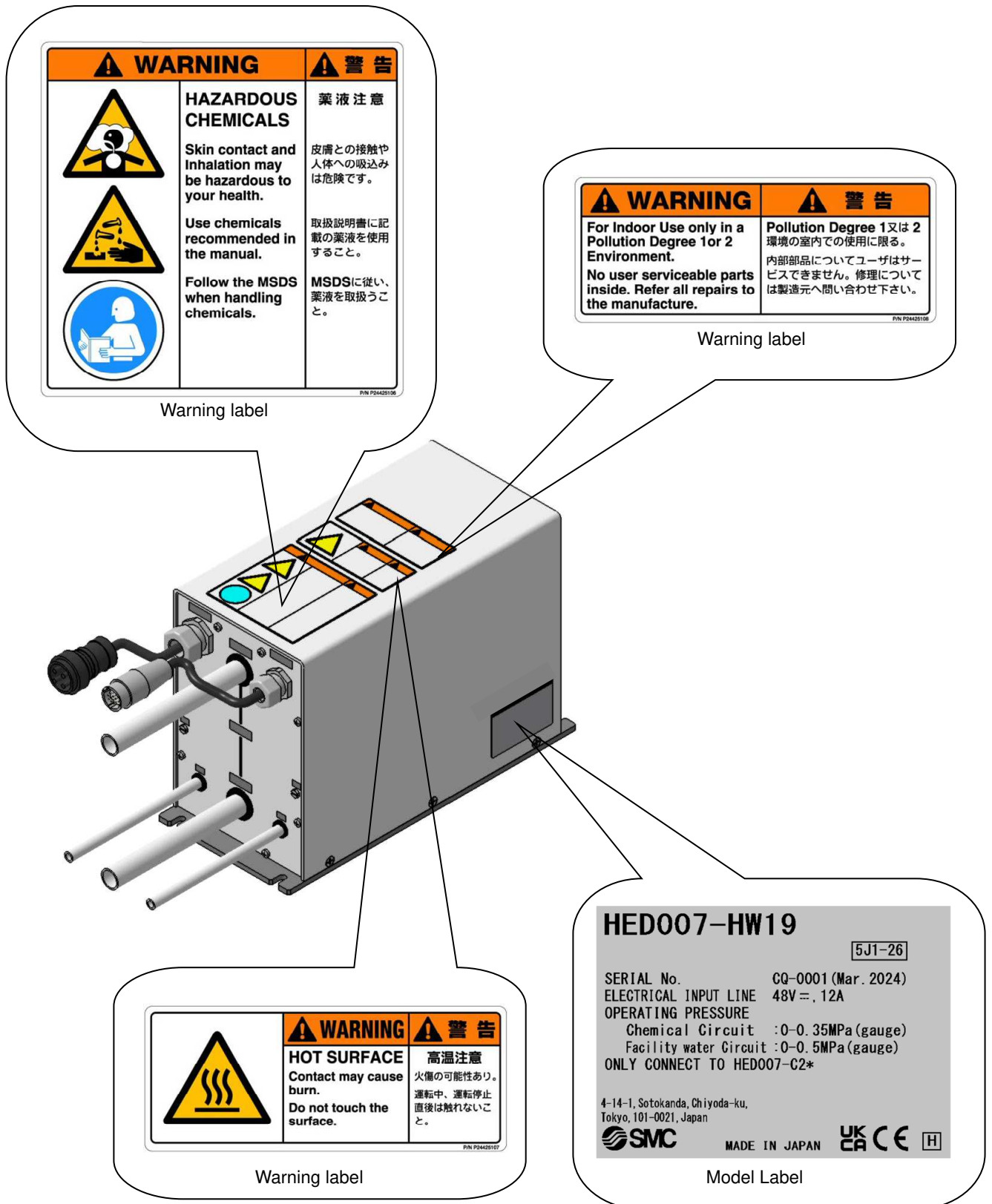

Fig. 1-5 Temperature controller

■ HED007-HW¹³₁₉ (Heat Exchanger)



WARNING		警告	
	HAZARDOUS CHEMICALS	薬液注意	
	Skin contact and Inhalation may be hazardous to your health.	皮膚との接触や人体への吸込みは危険です。	
	Use chemicals recommended in the manual.	取扱説明書に記載の薬液を使用すること。	
	Follow the MSDS when handling chemicals.	MSDSに従い、薬液を取扱うこと。	

Warning label

WARNING		警告	
For Indoor Use only in a Pollution Degree 1 or 2 Environment.		Pollution Degree 1又は2環境の室内での使用に限る。	
No user serviceable parts inside. Refer all repairs to the manufacture.		内部部品についてユーザはサービスできません。修理については製造元へ問い合わせ下さい。	

Warning label

	WARNING	警告
	HOT SURFACE	高温注意
Contact may cause burn.	火傷の可能性あり。	Do not touch the surface.
	運転中、運転停止直後は触れないこと。	

Warning label

HED007-HW19 5J1-26

SERIAL No. CQ-0001 (Mar. 2024)
 ELECTRICAL INPUT LINE 48V =, 12A
 OPERATING PRESSURE
 Chemical Circuit : 0-0.35MPa (gauge)
 Facility water Circuit : 0-0.5MPa (gauge)
ONLY CONNECT TO HED007-C2*

4-14-1, Sotokanda, Chiyoda-ku,
 Tokyo, 101-0021, Japan

MADE IN JAPAN

Model Label

Fig. 1-6 Heat Exchanger

■ HED009-HW25 (Heat Exchanger)

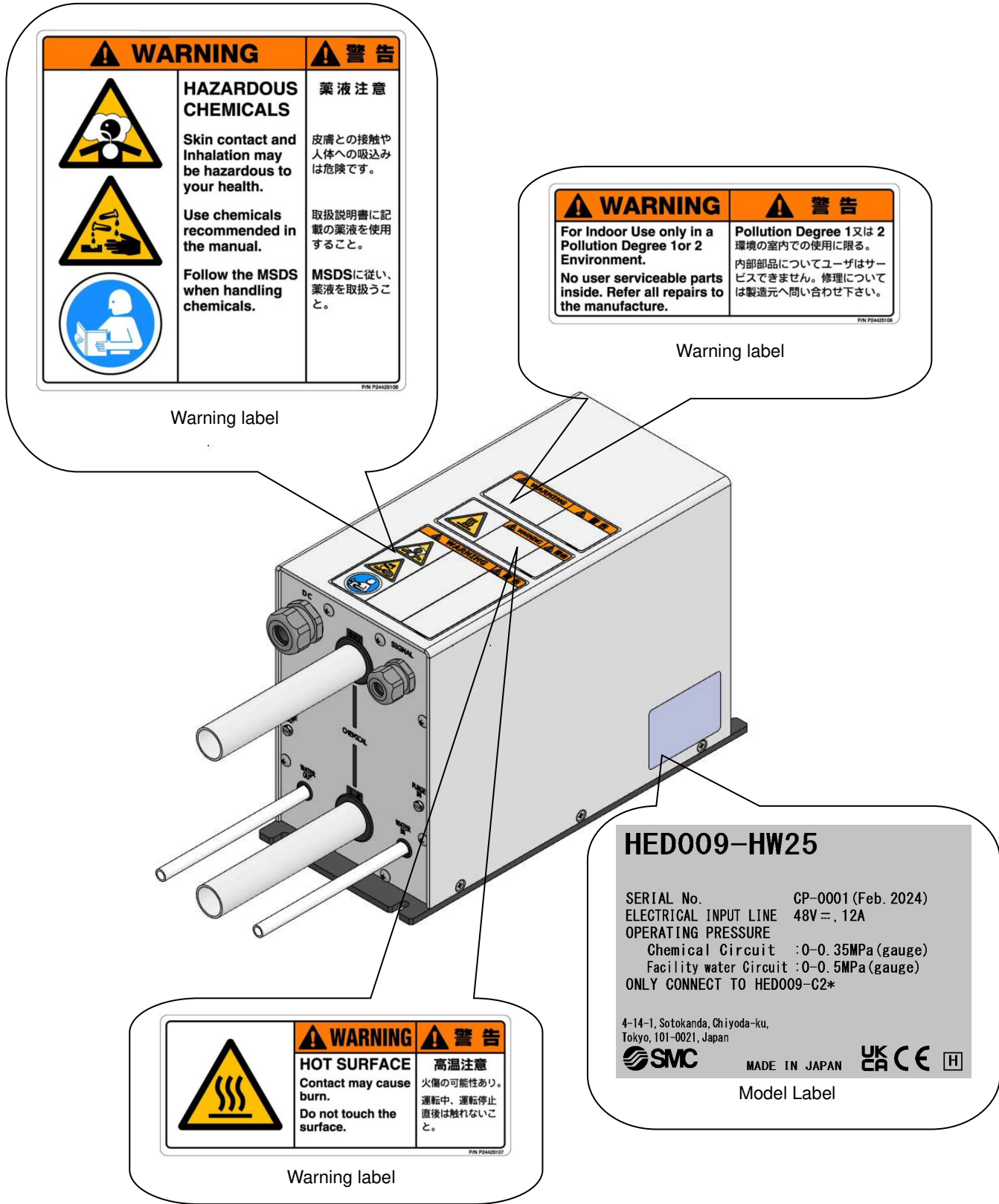

Fig. 1-8 Heat Exchanger

1.5 Safety Measures

1.5.1 Precautions

This product is designed with consideration for safety. However, misuse may result in electrical shock or other accidents.

Be sure to keep the following instructions in mind to prevent accidents.

⚠ WARNING



- Only operators that have sufficient knowledge and experience with electrical appliances and pneumatics should handle this product.
- Be sure that you understand how the chemical fluids use in this product affect the human body. Follow the SDS when handling chemical fluids.

⚠ WARNING



- Be sure that you understand how the chemical fluids use in this product affect the human body. Follow the SDS when handling chemical fluids.

⚠ WARNING



- Read the precautions described in this manual carefully and keep them strictly.

⚠ WARNING



- Perform checks on a regular basis. Perform checks on a regular basis to avoid unexpected operation failure. The checks should be performed by an operator who is trained and experienced for the product. The regular checks can also avoid unexpected breakdown of the product.

⚠ WARNING



- Stop operation immediately after any abnormal occurrence. If an abnormality (noise, odor, smoke, water leakage, etc.) occurs, stop this product (cutoff the power supply and stop the cooling water supply) and contact the sales distributor or branch for maintenance and repair.

Abnormal noise, odor, smoke or water leakage occurs;		<ol style="list-style-type: none">1) Cutoff power supply2) Stop water feed and supply3) Request repair
--	---	--

⚠ WARNING



- Do not disassemble or retrofit this product. The internal parts of this product cannot be retrofitted by the user. Contact the sales distributor or branch for all repairs. The user must not perform any repairs. A product repaired by the user cannot be guaranteed and carries the danger of causing electrical shock and other accidents.

CAUTION



- Margin of safe performance
Keep within the margin of safety in relation to cooling and heating capacity. Also, consider the safety margins of flow rate and drops in pressure because they are influenced by the piping conditions.

CAUTION



- Restarting power supply
When restarting the power supply, wait 3 sec or more after the indications on the display and operating panel disappear.

1.5.2 Protective Equipment

⚠ WARNING



- Wear protective equipment in order to maintain safety when installing and/or handling the product. When handling chemicals for the product especially, note the contents of the SDS and wear protective goggles, gloves, and a mask.



Protective goggles



Mask



Gloves



Safety shoes

Fig.1-1 Protective equipment

1.5.3 Long-term Storage

Cut off the power supply to the temperature controller. Drain the recirculating fluid from the heat exchanger, then flush the circuit with neutralizing agent and drain it. Drain the facility water from the heat exchanger.

1.5.4 Disposing of Product

When disposing of this product, be sure to use an industrial waste processing vendor that conforms to the “Law concerning disposal of waste and cleaning” and the “Ordinance defined by each municipal corporation”. Dispose of the recirculating fluid in the manner described in the SDS.

1.5.5 Safety Interlock

This is the function to protect personal, to restrict operation, which may cause damage to this unit or facility around, and to remove dangers related with safety and sanitation.

This unit has several interlock functions, which activates when danger operation or condition occurs to stop operation and make it safe.

Table 1-1 Interlock List

No.	Contents	Parts	Status of product after interlock works
1	Overheating of recirculating fluid circuit	Thermostat Circuit opened when 90°C or more is reached.	Control is stopped. Thermostat alarm “Error 14” occurs.
2	Overheating of facility water circuit	Thermostat Circuit opened when 60°C or more is reached.	
3	Liquid leakage	Leakage sensor	Control is stopped. Leak alarm “Error 22” occurs.

⚠ DANGER



During operation or maintenance of this unit, do not disable interlock function of each device. Otherwise it becomes improper and may cause unexpected personnel injury and damage this unit.

Chapter 2 Description and Function of Each Part

2.1 Temperature Controller

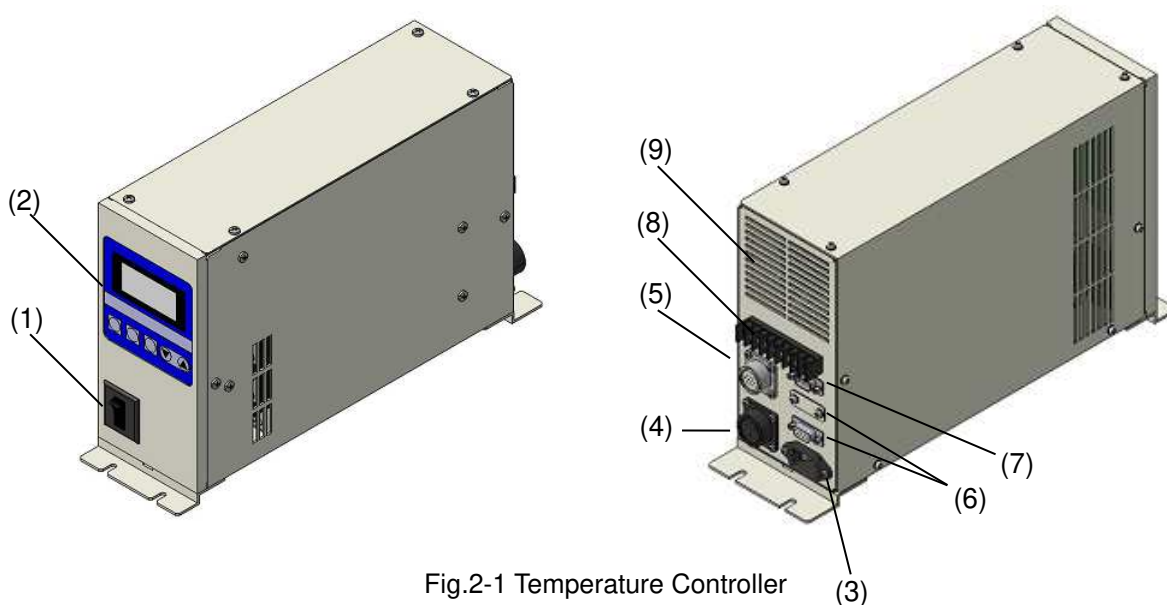

Fig.2-1 Temperature Controller

Table 2-1 Temperature Controller

No.	Name	Description
(1)	Circuit protector (Power switch)	Turns the power supply of the product on and off.
(2)	Display / operation panel	Various displays are shown and settings are input.
(3)	Power supply connector (AC)	Connector for the single phase AC (AC180 to 242V) power supply. A power supply cable is connected here.
(4)	DC Connector	Output DC power to Peltier device (Thermo-module). Which is connected from Heat Exchanger's DC cable.
(5)	Signal Connector	Connector for signal of control sensor and Thermostat etc. Which is connected from Heat Exchanger's signal cable.
(6)	Communication connector (RS-232C or RS-485)	Connector for communication with RS-485 or RS-232C. There are two connectors in RS-485 and one connector in RS-232C.
(7)	Alarm output connector (ALARM)	Connector for the upper/lower temperature limit alarm and output cut-off alarm. A relay contact is open or close when these alarms are output.
(8)	Terminal block (REMOTE ON/OFF and EXT. SENSOR)	To use learning control function and external sensor control function, external sensor is connected.
(9)	Fan (Outlet of air)	Fan for cooling the internal electric components of the controller. Air is sucked in from the controller side and discharged through the back via this fan.

2.2 Heat Exchanger

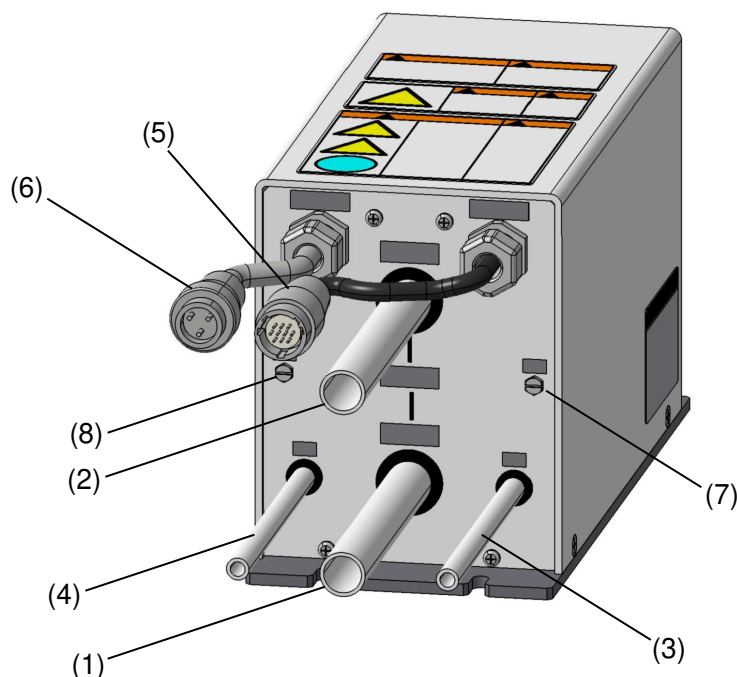

Fig.2-2 Heat Exchanger

Table 2-2 Heat Exchanger

No.	Name	Description
(1)	Recirculating fluid inlet (Chemical IN)	Inlet port of chemicals. PFA tube Port Size HED00*-HW13----- OD 1/2"×ID 3/8" HED00*-HW19----- OD 3/4"×ID 5/8" HED009-HW25----- OD 1" ×ID 7/8"
(2)	Recirculating fluid outlet (Chemical OUT)	Outlet port of chemicals. PFA tube Port Size HED00*-HW13----- OD 1/2"×ID 3/8" HED00*-HW19----- OD 3/4"×ID 5/8" HED009-HW25----- OD 1" ×ID 7/8"
(3)	Facility water inlet	Inlet port of facility water. FEP tube (port size OD 3/8"×ID 1/4")
(4)	Facility water outlet	Outlet port of facility water. FEP tube (port size OD 3/8"×ID 1/4")
(5)	Signal cable	Which is connected to temperature controller's Signal connector.
(6)	DC cable	Which is connected to temperature controller's DC connector.
(7)	Purge port (IN)	Inlet port of N ₂ or Dry air etc.
(8)	Purge port (OUT)	Outlet port of N ₂ or Dry air etc.

Chapter 3 Composition and Function of Product

3.1 Composition

It is structured from Heat exchanger: HED00*-HW* with built-in peltier device (Thermo-module) and Temperature controller: HED00*-C2* with built-in DC power for peltier device.

3.1.1 Outline

The Temperature Controller is used to control the temperature of the recirculating fluid flowing in the product. A temperature sensor placed inside of the Heat Exchanger (platinum resistive temperature detecting sensor) sends a signal to the Temperature Controller and the Temperature Controller adjusts the direction and time of the built-in DC power supply output depending on the deviation of the signal from the set temperature, which results in precise control of the recirculating fluid temperature.

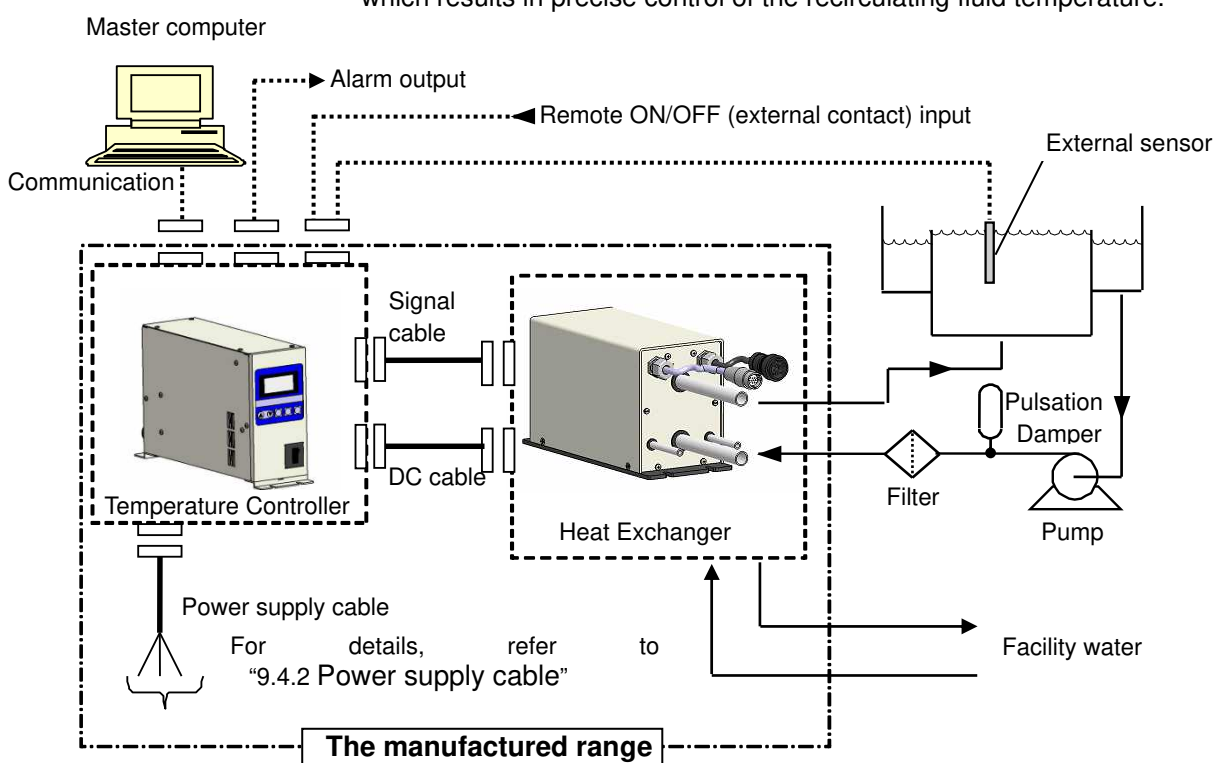

Fig. 3-1 Outline

Table3-1 Outline

Name	Model	Specification outline
Temperature Controller	HED00*-C2*	Temperature Controller with built-in DC power supply. Voltage: AC180V to 242V, single phase, 50/60Hz Ampere: HED003----- 3Amax. HED005----- 5Amax. HED007----- 14Amax. HED009----- 14Amax
Heat Exchanger	HED00*-HW*	Heat Exchanger controls temperature of recirculating fluid by control signal from Temperature Controller.

3.2 Function

3.2.1 Auto tuning function

This function automatically optimizes the PID values and others (proportional band, ARW value, integrating time, derivative time, cooling/heating gain ratio) necessary for control.

There are two types of auto tuning, “AT-1” using internal sensor and “AT-2” using external sensor. Either of them is used corresponding to the control operation mode selected in the Temperature Controller.

- AT-1; Performs auto tuning using the internal sensor of the Heat Exchanger when “normal control operation”, which is control operation mode using the internal sensor as a control sensor, is selected.
- AT-2; Performs auto tuning using external sensor when “external sensor control operation”, which is control operation mode using the external sensor as a control sensor, is selected. The external sensor needs to be prepared separately by the customer.

3.2.2 Off-set function

This function offsets the control temperature from the set temperature by a given value. It can be set in a range from -9.99 to 9.99°C. When the recirculating fluid is supplied from the product to the controlled object, the fluid is affected by the ambient temperature of piping on the way and will have constant temperature deviation at the position right before the object. In this case, the deviation is inputted as an offset value preliminarily to make the temperature of the recirculating fluid right before the object consistent with the set value.

3.2.3 Learning control function

This function sets a specific temperature sensor (mounted externally) to the temperature of the recirculating fluid right before controlled object, makes the product sample the temperature and offsets the sampled temperature to the set value with a given sampling frequency.

On the assumption that the recirculating fluid temperature lowers from a set temperature of 30°C by 0.2°C and reaches 29.8°C as shown on the following figure, when the learning control function is activated, the product increases the outlet temperature by 0.2°C to 30.2°C as shown by the dotted line, and offsets the temperature of the recirculating fluid right before controlled object to 30°C automatically.

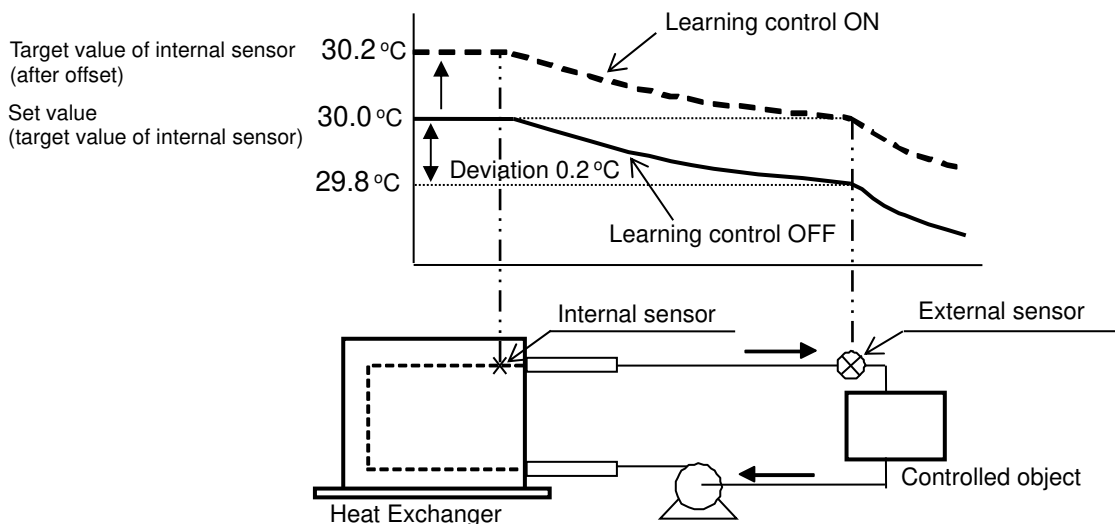

3.2.4 External sensor control function

This function uses the external temperature sensor as a control sensor and controls temperature directly. The offset function and upper and lower limit alarm will work in relation to the external sensor.

A specific external sensor needs to be prepared separately by the customer.

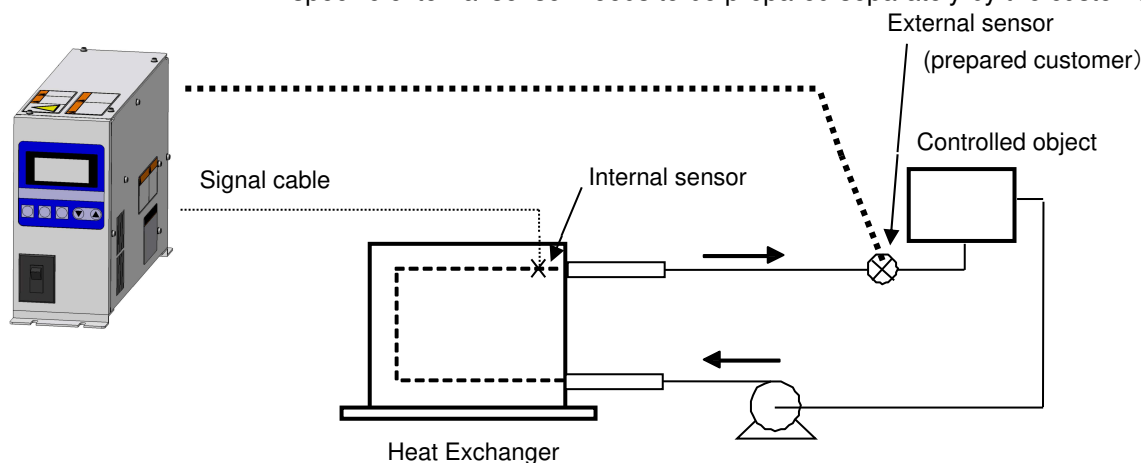

3.2.5 Temperature sensor fine control function

This function performs fine control of the temperature measured by the temperature sensor in a range of -9.99 to 9.99°C separately from offset function. The control sensor can be calibrated by inputting the difference (calibrated value) between temperature of standard and that of control sensor.

Internal sensor value for alarm includes the fine control value.

Internal sensor value for alarm = Internal sensor value – Fine control value

3.2.6 Memorization of Set values function (Function that backs up with EEPROM)

This function stores all set values inputted by the operation display panel into a nonvolatile memory EEPROM for backup. When the power supply is turned off once and restarted again, the product retains the conditions before the power supply is turned off and does not need to be set again.

If the memorization is performed by communication function, the set value is backed up into EEPROM only when the command “Saving of set values (Transfer of all data from RAM to EEPROM)” is used.

CAUTION



- The inputted data is written in EEPROM and memorized after the power supply is turned off. It should be noted that number of times that writing is possible is limited to approx. 1million.

3.2.7 Temperature Upper / Lower Limit Alarm Function

This function generates an alarm when the recirculating fluid temperature displaces from the set value over the upper or lower limit. When this alarm occurs, "WRN" is indicated on the LCD display and the temperature upper and lower limit connector receives an output through a relay contact. After the recirculating fluid temperature returns to within the upper and lower limit, the alarm goes off automatically. The upper and lower limits of the temperature can be set independently in a range of 0.1 to 10.0deg.C. Also, the temperature upper and lower limits will not occur until the product has reached the set temperature once after the power supply is turned on. This alarm can be set so that it is generated immediately after the power supply is turned on.

3.2.8 Communication Function

- HED00*-C2 **A** (Set part No: HED00*-W2 **A** *)

This product has a communication function conforming to communication protocol RS-485. The communication cable length is 500m in total. RS-485 enables one master computer to set and monitor operation conditions of up to 16 products.

- HED00*-W2**B*** (Set part No.: HED00*-W2 **B** *)

This product has a communication function conforming to communication protocol RS-232C. The communication cable length is 15m. RS-232C enables one master computer to set and monitor the operating conditions of only one product.

The communication contents are as follows.

- 1) Setting and reading of target temperature
- 2) Reading of current temperature (Internal sensor, External sensor)
- 3) Reading of alarm status
- 4) Setting and reading of off-set value
- 5) Setting and reading of control operation mode
- 6) Setting and reading of PB range
- 7) Setting and reading of ARW range
- 8) Setting and reading of I constant
- 9) Setting and reading of D constant
- 10) Reading of output ratio
- 11) Setting and reading of heating power upper limit
- 12) Setting and reading of cooling power upper limit
- 13) Saving of set values (Transfer of all data from RAM to EPROM)

3.2.9 Remote ON/OFF function

This function turns on and off the temperature control output of the product by switching the contact of an external device. It can restart temperature control by switching from "Remote OFF" to "Remote ON" without the power supply switch of the Temperature Controller turned on.

- Remote ON; Turns on the temperature control output of the product with external contact "Closed"
- Remote OFF; Turns off the temperature control output of the product with external contact "Open".

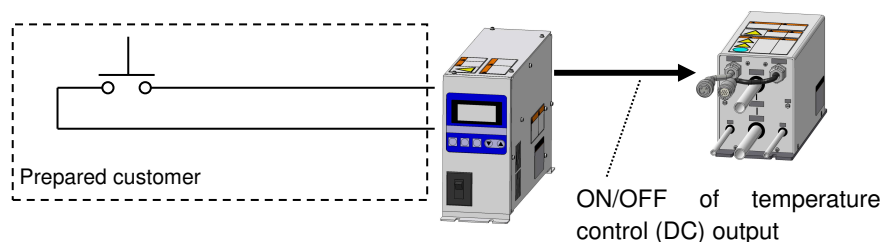

Before using this function, it is necessary to connect the terminals no. 1 and 2 of the terminal base at the back side of the Temperature Controller with the contact of the external device, which needs to be prepared separately by the customer. At the time of shipment from SMC's factory, a short piece is installed between the terminals no. 1 and 2 to make them short-circuited (Remote ON), and can be left if this function is not used.

MODE	External contact condition	Controller control status	Remarks
Remote ON	CLOSED	Ready to control	Default setting
Remote OFF	OPEN	Stopped for output	

When the circulating pump stops or the flow rate of recirculating fluids lowers, stop the temperature control of the product by using the remote OFF function.

CAUTION



- Be sure to avoid operation with the circulating pump stopped or with extremely small flow rate of recirculating fluid (7L/min or less for water). Otherwise, the product will repeat cooling and heating operation, which may shorten the life of the peltier device significantly, and it will become unable to control the temperature accurately. When the circulating pump is stopped, stop the temperature control of the product as well by using the remote ON/OFF function.

3.2.10 Output cutoff Alarm Function

This function performs a self-check function to cut off outputs to the peltier device, stop the operation (except for ERR 15 and ERR 18 whose operation is continued) and generates an alarm when a serious problem occurs. When the alarm occurs, "ERR" and the corresponding number are indicated on the LCD display and the output cutoff alarm connector receives an output through a relay contact. This alarm cannot be reset unless the power supply is turned off once and restarted again, for which a time interval of at least 3 sec. is required.

ERR 00: CPU Hung up

ERR 01: CPU Check Failure

ERR 03: Back-up Data Error

ERR 04: EEPROM Writing Error

ERR 05: EEPROM Input Over Times Error

ERR 11: DC Power Voltage Failure

ERR 12: Internal Sensor Value is High

ERR 13: Internal Sensor Value is Low

ERR 14: Thermostat Alarm

ERR 15: Output Failure Alarm (Abnormal output)

ERR 17: Cutoff/Short of Internal Sensor

ERR 18: Cutoff/Short of External Sensor

ERR 19: Auto-tuning Failure

ERR 21: Fan Alarm

ERR 22: Leak Alarm

Chapter 4 Installation

4.1 Installation, Transport and Transfer

CAUTION



- Pay special attention to keep safety of human body during installation and transportation of the unit.
- Only trained and experienced operators should perform installation, transportation and maintenance.

4.1.1 Transport and Transfer

*Avoid strong vibrations or impacts

This product is precise equipment and must not be subject to strong vibration or impact during transport and transfer.

4.1.2 Environment

The Chemical Thermo-con shall be installed on the following environments.

- 1) The installations, which allows the Chemical Thermo-con to become stable horizontally.
- 2) The installations without splashing water, salt water, oil, or various chemicals (including chemical mists), and particles or dust.
- 3) The installations without corrosive gas, an organic solvent and flammable gas. (Explosion proof is not provided.)
- 4) The installations with ambient temp. range of 10 to 35°C and humidity range of 35 to 80%. No condensation is allowed on the unit. The detail of due condensation is shown on "9.7 Calculation of Dew Point".
- 5) The installations without effect from noise source (such as discharging equipment, large relay and thyristor).
- 6) The installations with enough space between all cables of the Chemical Thermo-con and power line of other equipments.
- 7) The installations without strong electrical, magnetic emission or surge.
- 8) The installations, which allow power supply, ground to be made properly.
- 9) The installations without low molecular siloxane gas etc.
- 10) The installations, which doesn't interfere the suction and discharge port, required for refrigerant via fan. Do not install the unit in an enclosed container.
- 11) The installations with altitude of 1000m or less.

CAUTION



- Do not use or keep in outdoor, the place with the direct sunshine strikes and the radiation heats. That causes the breakdown.

4.1.3 Set-up in Clean Room

This product uses a fan and generates dust. When it is set up and operated in a clean room, take appropriate preliminary measures for dust.

⚠ CAUTION

!

- This product can be used in environments with contamination degree 1 or 2.

4.1.4 Installation

If the air inlet of Temperature controller and the outlet opening is not enough, the performance and product life might be degraded due to a decline of air flow. Install Chemical Thermo-con following condition. At the same time, when ambient temperature is in excess of 35°C, ventilate and exhaust air to prevent the ambient temperature from rising.

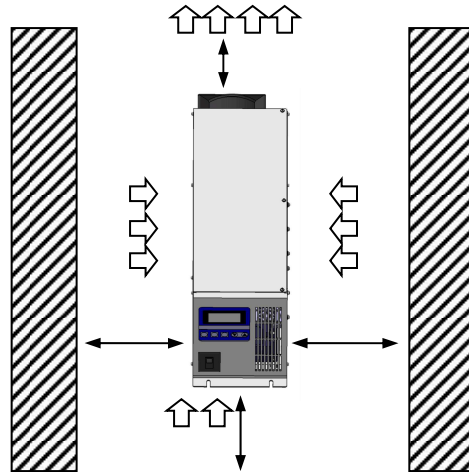

Fig. 4-1 Installation environment

⚠ WARNING

!

- Water drops may accumulate due to leakage of recirculating fluid or leakage of facility water due to failure, or condensation in piping. Install the product in an environment with drip pan, liquid leakage sensor and exhaust system installed. If leakage is detected, cut off the liquid recirculating circuit with hardware interlock, and cut off the power to this product. (Requirement of the safety guideline of SEMI)

⚠ WARNING

!

- For customer safety, observe the fluid temperature at the customer’s tool. Cut off the power to the product with a hardware interlock when abnormal temperature is detected. The observation temperature should be “the maximum set temperature +10 C” . (Requirement of the safety guideline of SEMI)

⚠ CAUTION

!

- Install this product with enough space for serviceman to handle this product safely and inspect periodically.

4.2 Piping

- The design of the system must be carried out by someone with sufficient knowledge and experience of this product and the equipment.

WARNING



- **Countermeasure for the liquid leakage**
Water drops may accumulate due to leakage of recirculating fluid or facility water due to failure, or condensation in the piping. Please take leakage into consideration when using this product. Depending on the type of chemical used (recirculating fluid) it may have a harmful effect on the surrounding equipment and the human body. It is the customer's responsibility to provide drip pan, liquid leakage sensor, exhaust system and emergency shut down system.

WARNING



- **Allow a margin in the length of piping.**
Check that the resin tube is long enough that no kink or collapse, and will not cause the fitting to come off, which will result in leakage. Fluid leakage can lead to a dangerous accident.

WARNING



- **Leakage Check**
The fluid leakage can cause dangerous accident. Be sure to check that the hose and tube do not come off and no leakage occurs from the fitting.

CAUTION



- **Avoid electrostatic discharge**
If a fluid with low conductivity, such as pure water is used as the recirculating fluid, static electricity generated by flow friction may damage the electrical part of the product and the temperature sensor. Consider measures to minimize static electricity from circulating fluid. Take measures to remove static electricity, for example using conductive PFA tubing or metal piping, and grounding as necessary.

CAUTION



- **Treatment before piping/tubing connection**
Remove foreign matter and scale from inside the piping/tubing by air blow (flushing) or washing.

CAUTION



- **Piping port**
When connecting facility water & recirculating line, do not mix up the ports of facility water side and recirculating fluid side, IN and OUT. Wrong set up can not make accurate temperature control, and also can damage the product.

⚠ CAUTION



- **Fitting connection**
 The fitting is not attached, and needs to be prepared separately by the customer. Select a fitting suitable for the material and dimensions of the tube. When connecting the fitting, use a specific tool specified by the fitting manufacturer.

4.2.1 Preparation of Facility Water

⚠ CAUTION



- **When using tap water as facility water, SMC recommends the water quality shown in the following table as reference.**

CAUTION



- **If there is possibility of foreign matters entering the product, install a filter (with 20 meshes or equivalent filtration).**

Table4-1 Quality standard for facility water (tap water)

	Item	Standard value
Quality item	pH (25°C)	6.5 to 8.2
	Electric conductivity (25°C) (µs/cm)	100 to 800
	Chloride ion (mgCl-/L)	200 or less
	Sulfate ion (mgSO ₄ ²⁻ /L)	200 or less
	Acid consumption (pH4.8) (mgCaCO ₃ /L)	100 or less
	Total hardness (mgCaCO ₃ /L)	200 or less
	Calcium hardness (mgCaCO ₃ /L)	150 or less
	Ion silica (mgSiO ₂ /L)	50 or less
	Iron (mgFe/L)	1.0 or less
	Copper (mgCu/L)	0.3 or less
	Sulfide ion (mgS ²⁻ /L)	None detected
	Ammonium ion (mgNH ₄ ⁺ /L)	1.0 or less
	Residual chlorine (mgCl/L)	0.3 or less
	Free carbon (mgCO ₂ /L)	4.0 or less

- Connect fittings to connecting ports “WATER IN” and “WATER OUT” of Heat Exchanger unit to connect input/output hoses of facility water.
- Temperature of facility water should be in the range of 10 to 35°C (No condensation). Notice that cooling and heating performance will be changed depending on facility water temperature. If the temperature of facility water is too low, it can cause condensation inside the Heat Exchanger. Supply facility water with a temperature over the atmospheric dew point to avoid the formation of condensation. Or take measure against condensation by performing N₂ purge. The detail of dew condensation is shown on “9.7 Calculation of Dew Point”.

- Flow rate should be **5-10L/min**.
When the flow rate of the facility water is not enough, cooling capacity will decline. Meanwhile, when the flow rate is extremely little, alarm (Err14) may occur and the temperature of the facility water might be extremely high. If resin tubing is used for piping under these circumstances, the tubing might get softened and exploded. Therefore, be sure to cool the facility water over time and flow the facility water with a proper flow rate.

⚠ CAUTION



- **Ensure to avoid cutting off facility water or operating with very little water flow less than 5L/min. Such situation may cause that cooling and heating capacity deteriorate significantly and the life of the peltier device may be shortened.**

⚠ CAUTION



- **The maximum operating pressure is 0.5MPa. Keep the pressure as low as possible to prevent water hammer.**

4.2.2 Preparation of Recirculating Fluid

- For the compatibility between the material of components and fluid, refer to "9.6 Applicable Fluids". For fluids other than those described on the check list, it is the customer's responsibility to determine whether the fluid is suitable by checking the compatibility between the fluid and wetted parts, or contact SMC separately.

[Wetted Material] PFA

- Connect fittings to connecting ports "CHEMICAL IN" and "CHEMICAL OUT" of Heat Exchanger unit to connect input/output tubing of recirculating fluid.
- When using pump which has liquid pulsation like bellows pump, circulate chemical liquid with lower pressure than the max. operating pressure (The max. operating pressure is 0.35MPa). And ensure to set pulsation damper before input tubing of Heat Exchanger to absorb fluid pulsation. Fluid pulsation will cause damages and liquid leakage in Heat Exchanger unit.
- The recommendation flow rate is **7 to 17L/min**. When operated with extremely small flow rate of recirculating fluid (7L/min for water), the product will repeat cooling and heating operation which may shorten the life of the peltier device significantly, and it will become unable to control the temperature accurately. Also, such extremely small flow rate can cause the thermostat alarm to be generated.

⚠ WARNING



- **This product is not designed to be explosion proof construction, and is not suitable for flammable fluids.**

⚠ WARNING



- The operating pressure range of recirculating fluid is 0 to 0.35MPa. In order to prevent product failure, install the Heat Exchanger at the discharge side of the circulating pump and avoid applying negative pressure. Also, even when used at positive pressure, take care that excessive pressure is not applied to the recirculating circuit by a clogged filter or fully closed valve, and keep the pressure as low as possible.

⚠ WARNING



- Correct any leakage of recirculating chemical fluid as well as any condition that drip fluid. Some recirculating chemical fluid has adverse effect on the human body and to other equipment. The user should install drip pan, liquid leak sensor, exhaust equipment, emergency stop device and others. If leakage is detected, cut off the liquid recirculating circuit with hardware interlock, and cut off the power to this product.

⚠ CAUTION



- Be sure to avoid operation with the circulating pump stopped or with extremely small flow rate of recirculating fluid (7L/min or less for water). Otherwise, the product will repeat cooling and heating operation, which may shorten the life of the peltier device significantly, and it will become unable to control the temperature accurately.
The appropriate flow rate is 7 to 17L/min.

4.2.3 Purge

- The product has purge supply / exhaust ports for prevention of condensation and internal build-up of corrosive gas. Purge should be applied if necessity.
<Examples of application>
 - Cooling operation at very low set temperature
 - When there is a possibility of condensation with low temp. facility water
 - When using a recirculating fluid which can generate corrosive gas
- Connect the fittings to the purge ports:[Purge IN] and [Purge OUT] on the front panel of the product. Purge ports are M5 screw female. (Recommended tightening torque: 0.5 to 0.65N·m)
- Use regulator for purge supply. Maximum purge pressure is 0.05MPa. Do not apply purge pressure over the maximum pressure.
- Purge flow rate should be 5 to 10L/min.
- The product cannot be sealed completely. Therefore all purge fluid may not come out from purge OUT port.

⚠ WARNING



- Purge should be applied for prevention of condensation and internal build-up of corrosive gas. Purge cannot be used for flammable fluids or harmful gases.

⚠ CAUTION



- Do not tighten the purge fitting to a torque of 0.65Nm or more. This can break M5 female thread

4.3 Wiring

4.3.1 Circuit Breaker (Ground Fault Circuit Interrupters)

- Chemical Thermo-con must be installed downstream of a Circuit Breaker. (UL 489 Listed and IEC 60947-2 Approved)

Current rating; HED003 ----- 10A or less

HED005 ----- 10A or less

HED007 ----- 20A or less

HED009 ----- 20A or less

⚠ WARNING



- Be sure to use a ring terminal suitable for the specifications of the power supply cable and a terminal block to connect them and supply power through the earth leakage breaker.

⚠ WARNING



- Terminate the power supply cable in a manner suitable to the specifications of the connected equipment. Do not use crimping after soldering.

4.3.2 Power Supply

The power supply shall be connected with attached power supply cable.

Confirm the power supply at factory has enough capacity and the voltage is within specified value beforehand (with reference to electrical specifications of the power supply). This unit is provided with the power supply cable. The power supply cable shall be connected properly in accordance with “9.4.2 Power supply cable”

Electrical specifications of the power supply

HED003 AC180-242V, 50/60Hz, 3A max. Single phase 2-wire type + GND (PE) line	HED005 AC180-242V, 50/60Hz, 5A max. Single phase 2-wire type + GND (PE) line	HED007 AC180-242V, 50/60Hz, 14A max. Single phase 2-wire type + GND (PE) line
HED009 AC180-242V, 50/60Hz, 14A max. Single phase 2-wire type + GND (PE) line		

⚠ CAUTION

 • This product is intended to be connected only to private low-voltage distribution systems. Do not connect to public low-voltage systems.

⚠ CAUTION

 • The cables attached to this product are designed specifically for the Chemical Thermo-con. Do not use them for other purposes. Also, never use other cables for this product.

⚠ CAUTION

 • Do not bend, pull or bind the power supply cable with a strong force. It may damage the power supply cord or potentially cause electric shock or fire.

4.3.3 Grounding

⚠ WARNING

 • The ground insulation class of this product is class I. Be sure to provide protective ground, which must be class D for Japan (ground resistance of 100ohm or less). Grounding can be provided via the PE line of the power supply cable. Do not use the same ground being used by equipment that generates strong electrical magnetic noise or high frequencies.

4.3.4 Avoidance of Parallel Wiring

Avoid parallel wiring or in-line wiring between the temperature sensor wire, communication line or signal line for alarm and power line or high-voltage line.

4.3.5 Incorrect Wiring

Incorrect wiring can damage the product or cause malfunction. Be sure to check wiring is connected properly.

4.3.6 Prevention of electrostatic discharge

⚠ CAUTION	
	<ul style="list-style-type: none">● Avoid electrostatic discharge If a fluid with low conductivity, such as pure water is used as the recirculating fluid, static electricity generated by flow friction may damage the electrical part of the product and the temperature sensor. Consider measures to minimize static electricity from circulating fluid. Take measures to remove static electricity, for example using conductive PFA tubing or metal piping, and grounding as necessary.

4.3.7 Removal of Cables

The worker must turn off the power supply before handling the cables.

4.3.8 Connection of Various Types of Connectors and Power Supply Plugs

- Ensure that the power source and the power supply of the product is turned off before connecting the various connector and power supply cable.
- When an external temperature sensor is connected, connect the sensor with a shield cable. Use a platinum resistance thermometer sensor. (Pt100ohm, 3-wiring type, class A, 2mA)
- If communications lines are used, connect the product and master computer with a twisted pair shielded cable to reduce the effects of noise.
- For alarm output, connect it with a twisted pair cable.
- The insulation class of this product is class I. Connect the power supply cable to a single phase power supply and ground. Be careful not to make a mistake such as connecting the power supply to ground. Frame ground is used as the PE ground of the power supply cable, and so needs a more secure grounding (class D).
- Also, the power supply should be provided with a ground fault circuit interrupter with appropriate electric capacity.

4.4 Installation

- Mounting position of the product should be horizontal.
- The temperature controller is air-cooled, so please ensure at least 50mm from the intake port and 100mm or more around the exhaust fan. Please refer to "4.1.4 Installation".
- When mounting, fix the foot of the Units by tightening the screws to the specified torque below. The mounting dimensions of the units can be found "9.3 Outline Dimensions".

Table 4-2 Recommended Torque for Mounting

Device to mount	Size of screw	Torque (N m)
Heat Exchanger	M6	1.5 to 2.5
Temperature Controller	M5	1.5 to 2.5

Chapter 5 Operation

5.1 Start of Operation

- 1.** Circulate Chemical and supply facility water to the Heat Exchanger.
- 2.** Turn on power supply switch of Temperature Controller.
- 3.** Display on Temperature Controller shows software version for about 2 seconds, after turning on power supply. And then the current temperature of recirculating fluid is indicated.
 - If alarm occurs after turning on power supply, see contents of errors, turn off power supply to investigate causes and take countermeasures.
- 4.** Errors which might occur at starting operation are as follows

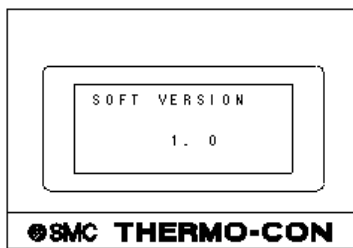

[ERR14]: It occurs when signal cable is not connected. Ensure to connections of Signal Cable.

[ERR17]: It occurs when signal cable is not connected. Ensure to connections of Signal Cable.

[ERR18]: It occurs when external temp. sensor is not connected.(This condition is detected only in learning control, external sensor control or autotning-2) Ensure to connections of external temp. sensor.

[WRN]: It occurs when the point of contact of REMOTE ON/OFF is opened. If the point of contact is closed, control is started.

5.2 Setting of Values

When the product has been found to start operating normally set the values such as temperature.

- 1.** Set each value such as target temp. and Temp. upper/lower limit.
- Set required values, referring to, "5.4Operation of Controller".

With this action, all preparation is complete. When the product is returned to the setting mode level 1, it will operate with these set conditions.

- 2.** Once values are set on the operation display panel, they will not be erased even when the power supply is turned off.

If all values need to be reset absolutely, press the [RET] and [SEL] buttons and turn on the power supply of the Temperature Controller. The data in EEPROM will be erased forcibly and initial values in ROM will be set.

CAUTION



- Be sure to operate the operation and display panel by finger. Using tools such as a screwdriver, pen, or pencil may damage the panel.

5.3 Cautions for Operation Control

- Wait at least 30 min. after the power supply is turned on before operating to allow the product to warm up.
- If an alarm comes on during operation, refer to, “6.4 Troubleshooting”, for the remedy.
- When low-temperature facility water is supplied, dew condensation may occur, damaging the internal electric equipment. Keep the facility water temperature over the atmospheric pressure dew point.

5.3.1 Indication and Setting when Output Cutoff Alarm Operates

- In case of setting mode level 1, indicator “**ERR**” and alarm code are shown.
- If output cutoff alarm operates when setting mode level 2 or level 3 is indicated, **ERR** is shown but mode data is continued to be indicated without showing alarm code, and setting can be done (Excepting **ERR00-ERR03**). Output cutoff and relay contact output are implemented normally.
- Alarm code is indicated if setting mode level 2 or level 3 returns to setting mode level 1.
- Even in alarming condition, by pushing [SEL] key, required function can be selected and set in every mode (Excepting **ERR00-ERR03**). If [RET] key is pushed, indication will return to **ERR** with alarm code.

5.4 Operation of Controller

5.4.1 Details of Operation and Display Panel



Fig. 5-1 Details of operation panel

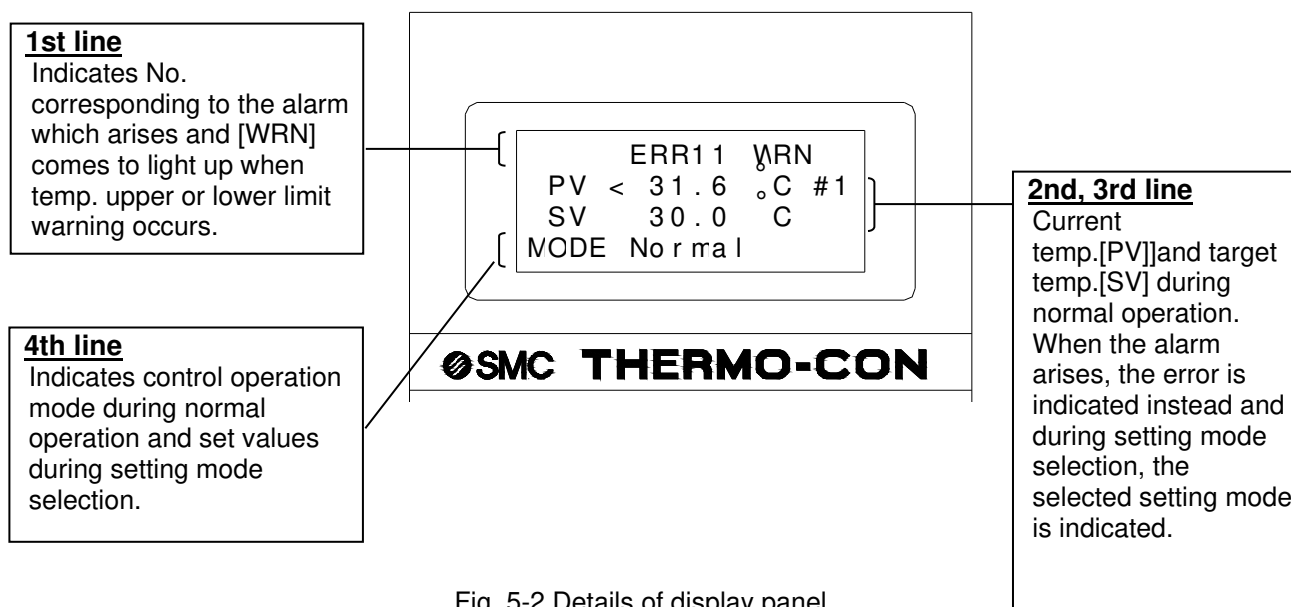
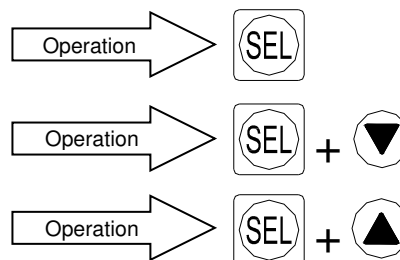

Fig. 5-2 Details of display panel

5.5 How to operate

1. The different 3 levels are available depending on the content, which needs to be set.

- Level 1 : Used normally and setting of target temp. and offset are included.(Refer to 5.5.1.)
- Level 2 : Used at maintenance and initial setting and the setting of control PID is included.(Refer to 5.5.3.)
- Level 3 : Used rarely for the purpose other than initial setting and communication setting is included. (Refer to 5.5.5.)



2. [SEL] key

Used to show the item, which needs to be changed in selected mode level.

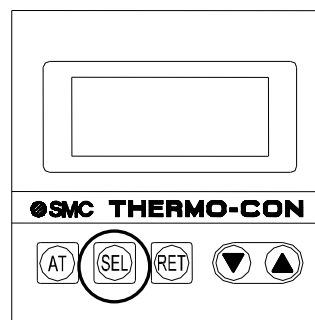

3. [▼ ▲] key (up/down key)

Used to change the value of the item shown by [SEL] key. Keep pressing the [▼ ▲] key for continuous increase or decrease.

The input data will be set approx. 2 sec. after the [▼ ▲] key is released.

Data outside of the setting range can not be input.

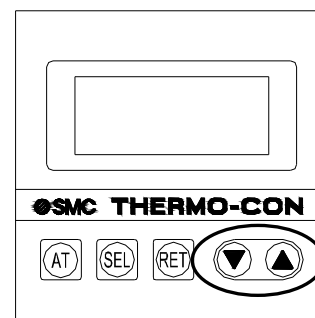

4. [RET] key

Used to fix the value changed by [▼ ▲]key.

Press the [RET] key to enter the value. If the [RET] key is pressed again, the initial display of each setting mode level will appear, and pressing the same key once more will make the display return to the present temperature displayed.

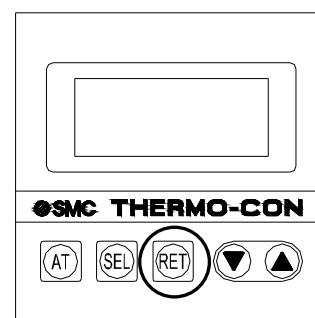

5. [AT] key

Used to start auto tuning in auto tuning mode (control operation mode: 2 or 4). When pressed during auto tuning, the auto tuning is suspended.

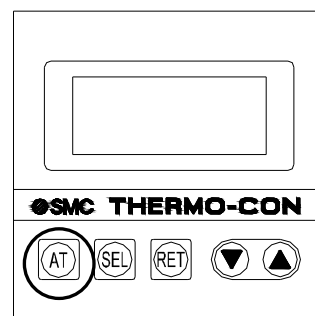

5.5.1 Setting Mode, Level 1

When the power supply is turned on, the product is in setting mode level 1. Each press of the [SEL] key changes the setting mode level 1 display as follows.

To return to current temperature indication, press [RET] key once.

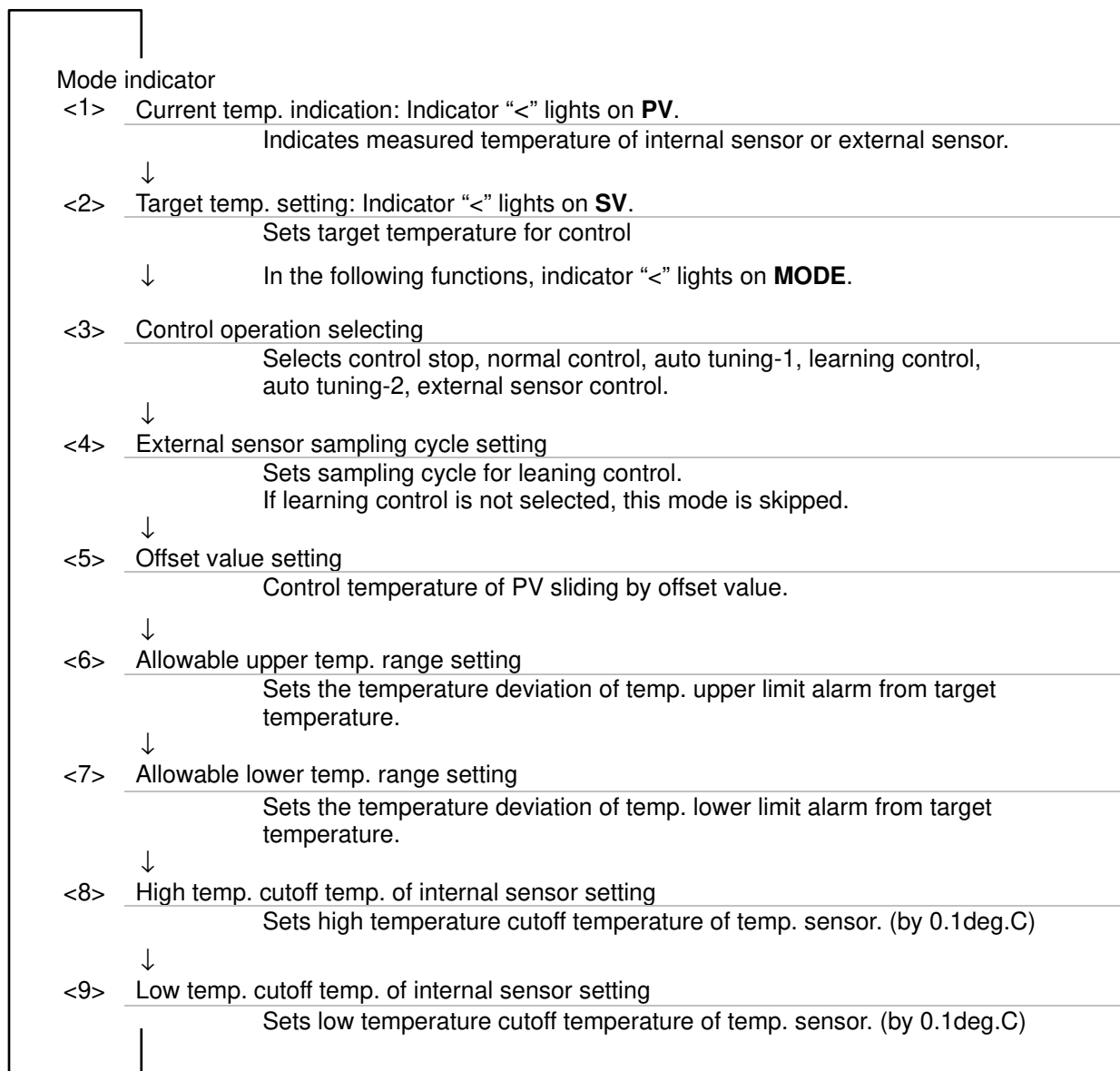

5.5.2 Detail of setting mode level 1

<1> Current temp indication: Indicator “<” lights on **PV**.

```
PV < 23.0 °C #1
SV   23.0 °C
MODE Normal
```

<current temp. indication of internal sensor>

```
PV < 23.0 °C #2
SV   23.0 °C
MODE Normal
```

<current temp. indication of external sensor>

Indicating range	-9.9 to 80.0°C
Indicated contents	Measured temperature of internal sensor and external sensor
Function	Indicates measured temp. Indication “#1” means temp. measured by internal sensor and indication “#2” means temp. measured by external sensor. #1 and #2 change when [▲] or [▼] is pressed.

[Tips]

No key-in operation for 1 min.

- If no key-in operation has been performed for 1 min., the display will return automatically to the current temperature indication even if it is any setting mode.

<2> Target temp. setting: Indicator “<” lights on **SV**.

Default value: 25.0°C

```
PV   23.0 °C #1
SV < 23.0 °C
MODE
```

Setting range	10.0 to 60.0°C
Indicated contents	Target temperature
Function	Sets target temperature for control.

In the following functions, indicator “<” lights on **MODE**.

<3> Control operation selecting: Mode indication “Operation control”

Default value: 1: Normal

```
Control
Operation
MODE< 1:Normal
```

Setting range	0 to 5
Indicated contents	Number and description of control operation mode. “Control Operation” indicates that it is selecting control operation mode.
Function	Selects the following control operation 0: stop; Control stop 1: Normal; Normal control operation 2: AT-1; Auto tuning for normal control operation 3: Learn; Learning control operation 4: AT-2; Auto tuning for external sensor control operation 5: External; external sensor control operation

[Tips]

How to perform Auto tuning

1. For details of auto tuning, refer to "3.2.1 Auto tuning function".
2. Appropriate PID values are input at the time of shipment from the factory. If the temperature deviation is found at these values on a regular basis, try to perform auto tuning. The Controller will calculate and set PID values automatically. Auto tuning may require a significant amount of time to complete, depending on the operating conditions.
2. Select "2" or "4" in "Control operation selecting"
3. Press [AT] key to light up "AT-1" or "AT-2" indicator. Auto tuning starts.
4. To stop auto tuning, press [AT] key again. ("AT-1" or "AT-2" indicator goes off.)
5. When auto tuning is finished, "AT-1" or "AT-2" indicator goes off. If the auto tuning is not finished over 60min, [ERR19] (AT Failure) arises and output is cut off. Turn off power supply once and turn it on again to start operation.
6. If the auto tuning fails, return to the set value at the time of shipment from factory or input optimum PID value (proportional band, ARW value, integral time and derivative time) by hand.

During Auto tuning	Auto tuning failure
AT-1 PV < 23.0 °C #1 Auto Tuning Cancel: AT key	ERR19 AT Failure MODE Shut Off

<4> External sensor sampling cycle setting: Mode indication "External Sensor Sampling Cycle".

Default value: 180 sec.

External Sensor Sampling Cycle MODE < 180 sec

Setting range	10 to 999 sec.
Indicated contents	External sensor sampling cycle " External Sensor Sampling Cycle " indicates that external sensor sampling cycle setting mode.
Function	Sets sampling cycle of external sensor for learning control.

<5> Offset value setting: Mode indication "Offset Value"

Default value: 0°C

Offset Value MODE < -0.15 °C
--

Setting range	-9.99 to 9.99°C
Indicated contents	Offset value " Offset Value " indicates that it is offset value setting mode.
Function	This is function to control temperature sliding it by offset value from temperature. For example, if -1.0°C is set in this item, the actual temp. should be regarded to be lower than the indicated one by 1.0°C.

<6> Allowable upper temp. range setting: Mode indication "Allowable Upper Temp. Range"
 Default value: 1.5°C

Allowable Upper Temp. Range MODE < 10.0 °C	Setting range	0.1 to 10.0°C
	Indicated contents	Temp. from target to upper limit " Allowable Upper Temp. Range " indicates that it is allowable upper temp. range setting mode.
	Function	Sets upper limit of temp. where the warning occurs. The difference between target temp. and upper limit temp. should be input.

<7> Allowable lower temp. range setting: Mode indication "Allowable lower Temp. Range".
 Default value: 1.5°C

Allowable Lower Temp. Range MODE < 10.0 °C	Setting range	0.1 to 10.0°C
	Indicated contents	Temp. from target to lower limit " Allowable lower Temp. Range " indicates that it is allowable lower temp. range setting mode.
	Function	Sets lower limit of temp. where the warning occurs. The difference between target temp. and lower limit temp. should be input.

[Tips]

WRN PV < 25.6 °C #1 SV 23.0 °C MODE Normal	<p><u>Status when temp. upper/lower limit alarm occurs.</u></p> When temp. upper/lower limit alarm occurs, indicator WRN lights on. Since control is continued, indicator WRN turns off when temperature returns to within upper/lower limit temp. range.
---	---

<8> High temp. cutoff temp. of internal sensor setting: Mode indication "High Temp. Cutoff"
 Default value: 70.0°C

High Temp. Cutoff MODE < 70.0 °C	Setting range	11.0 to 70.0°C
	Indicated contents	High temp. cutoff temp. of internal sensor " High Temp. Cutoff " indicates that it is high temp. cutoff temp .of internal sensor setting mode.
	Function	Sets upper limit of temp. which the internal temp. sensor detects and judge the unit should be shut off.

<9> Low temp. cutoff temp. of internal sensor setting: Mode indication "Low Temp. Cutoff"
 Default value: 0.0°C

Low Temp. Cutoff MODE < 0.0 °C	Setting range	0.0 to 59.0°C
	Indicated contents	Low temp. cutoff temp. of internal sensor " Low Temp. Cutoff " indicates that it is low temp. cutoff temp .of internal sensor setting mode.
	Function	Sets lower limit of temp. which the internal temp. sensor detects and judge the unit should be shut off.

5.5.3 Setting Mode, Level 2

This mode is used mainly for initial setting or maintenance such as the setting of the control PID value. This mode can be entered by pressing the [SEL] and [▼] keys simultaneously with the power on. Each press of the [SEL] key changes the setting mode level 2 display as follows.

To return to current temperature indication, press [RET] key twice.

In the following functions, indicator “<” lights on **MODE**.

Mode indicator

- | | | |
|------|--|--|
| <1> | Fine control of internal sensor value setting | Sets the fine adjusting value to calibrate the internal temp. sensor. |
| | ↓ | |
| <2> | Fine control of external sensor value setting | Sets the fine adjusting value to calibrate the external temp. sensor. |
| | ↓ | |
| <3> | PB range setting | Sets PB (Proportional Band) range used for PID control. |
| | ↓ | |
| <4> | ARW range setting | Sets integral operation range of PID control. |
| | ↓ | |
| <5> | I constant setting | Sets integral time used for PID control |
| | ↓ | |
| <6> | D constant setting | Sets derivative time used for PID control |
| | ↓ | |
| <7> | Heating/Cooling gain ratio setting | Sets output ratio of cooling to heating compensate difference of gain between them. |
| | ↓ | |
| <8> | Overload judging temp. range setting | Sets the temp. range for judgment of overload. |
| | ↓ | |
| <9> | Overload judging time setting | Sets time for judgment of overload |
| | ↓ | |
| <10> | Output ratio indication | Indicates output ratio of controller |
| | ↓ | |
| <11> | Temp. upper/lower limit alarm sequence setting | Determines whether or not temp. upper/lower limit alarm is output when power is turned on. |
| | ↓ | |
| <12> | Heating power upper limit value setting | Sets upper limit value of heating output ratio |
| | ↓ | |
| <13> | Cooling power upper limit value setting | Sets upper limit value of cooling output ratio |

[Tips]

No key-in operation for 1 min.

- If no key-in operation has been performed for 1 min., the display will return automatically to the current temperature indication even if it is any setting mode.

5.5.4 Detail of setting mode level 2

<1> Fine control of internal sensor value setting: Mode indication “Fine Control of Internal Sensor”
Default value: 0.00°C

**Fine Control of
Internal Sensor**
MODE< -0.32 °C

Setting range	-9.99 to 9.99°C
Indicated contents	Fine adjusting value for internal sensor “ Fine Control of Internal Sensor ” indicates that it is fine control of internal sensor setting mode.
Function	Sets the fine adjusting value to calibrate the internal temp. sensor. If -0.32 °C is set in this item, the reading of temp. sensor is higher by 0.32 °C and actually, the temp. is controlled to lower one by 0.32 °C

<2> Fine control of external sensor value setting: Mode indication “Fine Control of External Sensor”
Default value: 0.00°C

**Fine Control of
External Sensor**
MODE< -3.82 °C

Setting range	-9.99 to 9.99°C
Indicated contents	Fine adjusting value for external sensor “ Fine Control of External Sensor ” indicates that it is fine control of external sensor setting mode.
Function	Sets the fine adjusting value to calibrate the external temp. sensor. If -3.82 °C is set in this item, the reading of temp. sensor is higher by 3.82 °C and actually, the temp. is controlled to lower one by 3.82 °C.

<3> PB range setting: Mode indication “PB Range”
Default value: 1.0°C

PB Range
MODE< 1.0 °C

Setting range	0.3 to 9.9°C
Indicated contents	PB range (Proportional band) “ PB Range ” indicates that it is PB range setting mode.
Function	Sets PB range used for PID control.

<4> ARW range setting: Mode indication “ARW Range”
Default value: 1.1°C

ARW Range
MODE< 1.1 °C

Setting range	0.3 to 9.9°C
Indicated contents	ARW range (Anti reset windup) “ ARW Range ” indicates that it is ARW range setting mode.
Function	Sets integral operation range of PID control. If this value is set less than PB range, the set temperature can't be achieved. Therefore set it above PB range.

<5> I constant setting: Mode indication “I Constant”
Default value: 150 sec.

I Constant
MODE< 150 sec

Setting range	1 to 999 sec.
Indicated contents	I constant (Integral time) “ I Constant ” indicates that it is I constant setting mode.
Function	Sets integral time used for PID control/

<6> D constant setting: Mode indication "D Constant"
Default value: 0 sec.

D Constant MODE< 0.0 sec	Setting range	0.0 to 99.9 sec.
	Indicated contents	D constant (Derivative time) "D Constant" indicates that it is D constant setting mode.
	Function	Sets derivative time used for PID control. When 0 is set, this function becomes invalid. (PI control)

<7> Heating/Cooling gain ratio setting: Mode indication "Heating/Cooling Ratio"
Default value: 200 %

Heating / Cooling Ratio MODE< 200 %	Setting range	10 to 999 %
	Indicated contents	Heating/Cooling gain ratio "Heating/Cooling Ratio" indicates that it is Heating/Cooling gain ratio setting mode.
	Function	Sets output ratio of cooling to heating to compensate difference of gain between them.

<8> Overload judging temp. range setting: Mode indication "Overload Judging Temp. Range"
Default value: 0.2°C

Overload Judging Temp. Range MODE< 1.0 °C	Setting range	0.1 to 9.9°C
	Indicated contents	Overload judging temp. range "Overload Judging Temp. Range" indicates that it is overload judging temp. range setting mode.
	Function	Sets the temp. range for judgment of overload (accompanying output failure alarm ERR15).

<9> Overload judging time setting: Mode indication "Overload Judging Time"
Default value: 10 min.

Overload Judging Time MODE< 10 min	Setting range	0 to 99 min.
	Indicated contents	Overload judging time "Overload Judging Time" indicates that it is で示します。
	Function	Sets time for judgment of overload (accompanying output failure alarm ERR15). When 0 is set, the alarm doesn't occur.

<10> Output ratio indication: Mode indication "Output Ratio"

Output Ratio MODE< -100 %	Setting range	-100 to 100%
	Indicated contents	Output ratio of controller "Output Ratio" indicates that it is output ratio indication mode.
	Function	Temp. Controller output ratio with increment of 1%. "+" is not indicated but "+" means heating and "-" means cooling.

<11> Temp. upper/lower limit alarm sequence setting: Mode indication
"Upper/Lower Temp. Alarm Sequence"
Default value: Off

Upper/Lower Temp Alarm Sequence MODE< Off	Setting range	On or Off
	Indicated contents	Use of Temp. upper/lower limit alarm sequence "Upper/Lower Temp. Alarm Sequence" indicates that it is Temp. Upper/lower limit alarm sequence setting mode.
	Function	Determines whether or not temp. upper/lower limit alarm is output when power is turned on. On : Output Off : Not output (Alarm for high and low temperature limit is not detected until the temperature reaches the target temperature after the power is supplied.)

<12> Heating power upper limit value setting: Mode indication “Heating Power Upper Limit”
 Default value: 100 %

Heating Power Upper Limit MODE < 80 %
--

Setting range	0 to 100%
Indicated contents	Heating power upper limit value “ Heating Power Upper Limit ” indicates that it is heating power upper limit value setting mode.
Function	Sets the upper limit of heating output ratio of the Temperature Controller when necessary. For instance, if this value is set to 80%, the maximum heating output ratio is limited to 80%.

<13> Cooling power upper limit value setting: Mode indication “Cooling Power Upper Limit”
 Default value: -100 %

Cooling Power Upper Limit MODE < - 80 %
--

Setting range	-100 to 0%
Indicated contents	Cooling power upper limit value “ Cooling Power Upper Limit ” indicate that it is cooling power upper limit value setting mode.
Function	Sets the upper limit of cooling output ratio of the Temperature Controller when necessary. For instance, if this value is set to -80%, the maximum cooling output ratio is limited to -80%.

5.5.5 Setting Mode, Level 3

This mode is used to select a communication method.
This mode can be entered by pressing the [SEL] and [▲] keys simultaneously with the power on. Each press of the [SEL] key changes the setting mode level 3 display as follows.

To return to current temperature indication, press [RET] key twice.

In the following functions, indicator “<” lights on **MODE**.

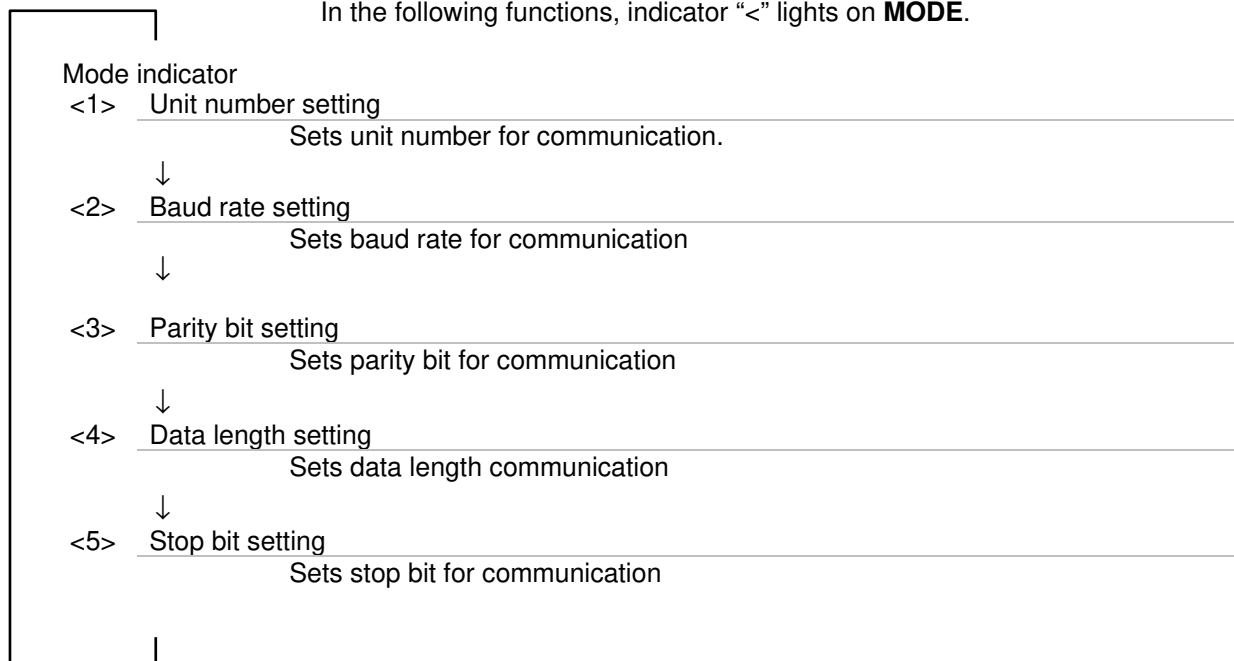

5.5.6 Detail of setting mode level 3

<1> Unit number setting: Mode indication “Unit Number”
Default value: 0

Unit Number
MODE< 1

Setting range	0 to F(Hexadecimal)
Indicated contents	Unit number “Unit Number” indicates that it is unit number setting mode.
Function	Sets unit number for communication. When multiple Chemical Thermo-cons are used, unit number of each one is specified by hexadecimal.

<2> Baud rate setting: Mode indication “Baud Rate”
Default value: 1200 b/s

Baud Rate
MODE< 19200 b/s

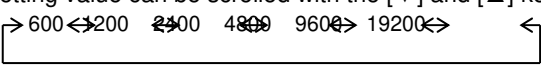
Setting range	600, 1200, 2400, 4800, 9600, 19200 b/s
Indicated contents	Baud rate “Baud Rate” indicates that it is baud rate setting mode.
Function	Sets baud rate for communication. Setting value can be scrolled with the [▼] and [▲] keys. 

<3> Parity bit setting: Mode indication "Parity Bit"
 Default value: Without

Parity Bit MODE< Without
--

Setting range	Without, Odd, Even
Indicated contents	Parity bit " Parity Bit " indicates that it is parity bit setting mode.
Function	Sets parity bit for communication. Without: Without parity Odd: Odd number Even: Even number

<4> Data length setting: Mode indication "Data Length"
 Default value: 8 Bits

Data Length MODE< 8 Bits
--

Setting range	7 Bits, 8Bits
Indicated contents	Data length " Data Length " indicates that it is data length setting mode.
Function	Sets data length for communication.

<5> Stop bit setting: Mode indication "Stop Bit"
 Default value: 1 Bit

Stop Bit MODE< 1 Bit
--

Setting range	1 Bit, 2Bits
Indicated contents	Stop bit " Stop Bit " indicates that it is stop bit setting mode.
Function	Sets stop bit for communication.

Chapter 6 Alarms

6.1 How to Identify Alarm

The alarm is identified as shown on the following table.

Table 6-1 Alarm information

No.	Condition	After Alarm Occurrence	Indication example
1	Power supply on	After indication of software version, the error No. [ERR**] starts blinking and then the contents of the error comes out. As [MODE], "Shut Off" is indicated. ("Continuity" is indicated instead for ERR15 and ERR18 because the operation is continued.)	Fig.6-1
2	Normal operation	The value of PV and SV disappear and instead, the error No. [ERR**] starts blinking and the content of the error comes out. As [MODE], "Shut Off" is indicated. ("Continuity" is indicated instead for ERR15 and ERR18 because the operation is continued.)	
3	Set value input	Even during input of each setting, the error No. [ERR**] starts blinking on the upper side. After input (pressing [RET] key to set), the content of the error comes out.	Fig.6-2
4	Temp. upper/lower limit alarm occurrence	The value of PV and SV and the indication of [MODE] remained, [WRN] lights up. After the error is reset, the indication of [WRN] disappears.	Fig.6-3
5	Remote off alarm occurrence	The value of PV and SV remained, [WRN] lights up. As [MODE], "Remote Off" is indicated. (If ERR15 or ERR18 is occurred at the same time, "Continuity" is indicated.) After the error is reset (Remote ON), the indication of [WRN] disappears.	Fig.6-4

6.2 Alarm indication

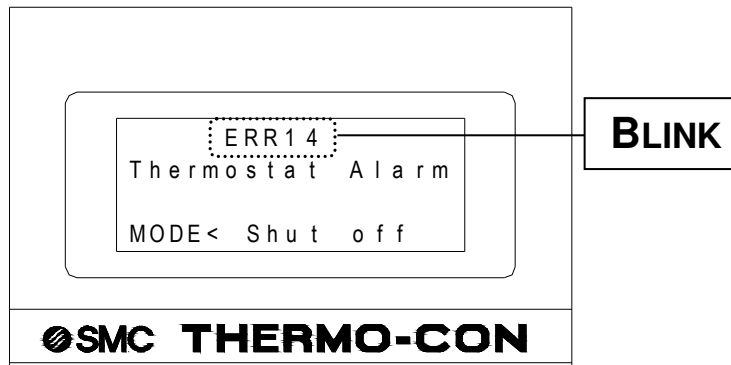

Fig. 6-1 Alarm indication in the event ERR14 occurs

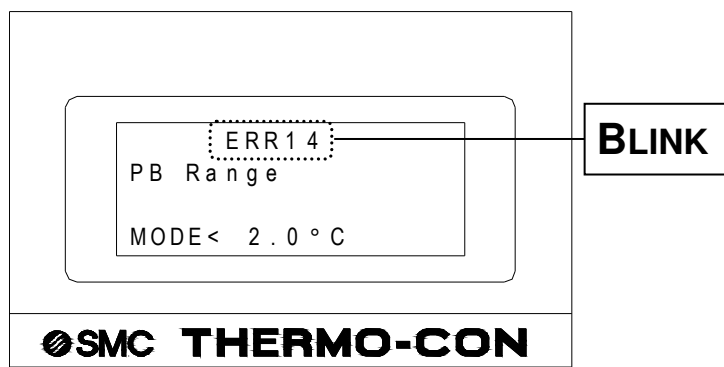

Fig. 6-2 Alarm indication in the event ERR14 occurs during PB range setting input

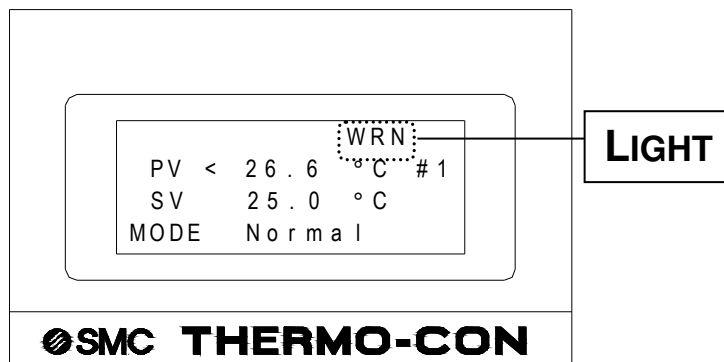

Fig. 6-3 Alarm indication in the event temp. upper and lower limit occurs

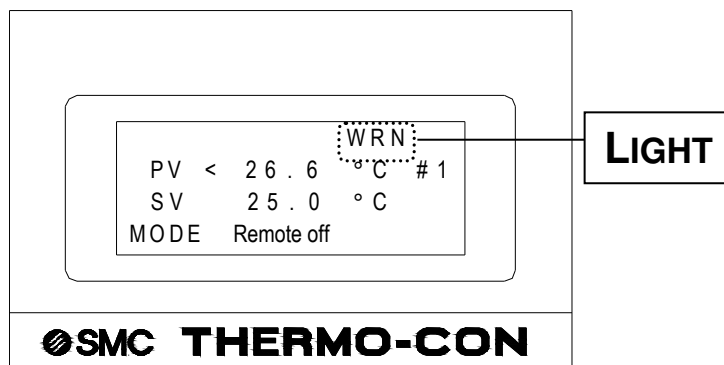

Fig. 6-4 Alarm indication in the event Remote off occurs

6.3 Content of Alarms

Table 6-2 Content of alarm (1/2)

Alarm Code	Contents of Alarm	Output cut-off alarm	Temp. upper/lower limit alarm	Condition after alarming	How to reset
WRN	Temp. Upper Limit Alarm Occurs when temp. sensor value (Note 1) exceeds the value of adding temp. upper limit to target temp.	-	ON	Normal operation	Reset automatically
WRN	Temp. Lower Limit Alarm Occurs when temp. sensor value (Note 1) lowers the value of drawing temp. lower limit from set temp.	-	ON	Normal operation	Reset automatically
WRN	Remote OFF Alarm Occurs when the remote on/off contact input of the Temperature Controller is opened.(Note 3).	-	-	Control stops	Switch to Remote ON
ERR00	CPU Hung up Hung up of CPU due to noise.	ON	-	Device stops Communication stops	Restart the power supply.
ERR01	CPU check Failure CPU check error when the power supply is turned on.	ON	-	Device stops Communication stops	Replace ROM
ERR03	Back-up Data Error Corrupted EEPROM data when the power supply is turned on.	ON	-	Device stops Communication stops	Readjust EEPROM
ERR04	EEPROM Writing Error EEPROM doesn't allow writing of the data	ON	-	Device stops Communication stops	Readjust EEPROM
ERR05	EEPROM input Over Times Error Occurs when the number of times of writing to EEPROM has exceeded the limit of 1 million.	ON	-	Device stops Communication stops	Readjust EEPROM
ERR11	DC Power Voltage Failure Occurs for voltage sag of the AC power supply, abnormal high temperature of the DC power supply or short-circuit of peltier device.	ON	-	Device stops	Restart the power supply
ERR12	Internal Sensor Value is High. Occurs when internal sensor value for alarm (Note 2) exceeds internal sensor high temp. cutoff alarm.	ON	-	Device stops	Restart the power supply
ERR13	Internal Sensor Value is Low Occurs when internal sensor value for alarm (Note 2) falls below the internal sensor low temp. cutoff alarm.	ON	-	Device stops	Restart the power supply
ERR14	Thermostat Alarm Occurs when overheat detecting thermostat is operated due to high temperature.	ON	-	Device stops	Restart the power supply

Table 6-2 Contents of Alarm (2/2)

Alarm Code	Contents of Alarm	Output cut-off alarm	Temp. upper/lower limit alarm	Condition after alarming	How to reset
ERR15	Output Failure Alarm Occurs when temp. change is less than overload judging temp. range even by 100% output for overload judging time period due to application of unacceptable heat load or broken of peltier device.	ON	-	Operation continues	Restart the power supply
ERR17	Cutoff/short of Internal Sensor Occurs when internal sensor is opened, shorted or disconnected.	ON	-	Device stops	Restart the power supply
ERR18	Cutoff/short of External Sensor Occurs when external sensor is opened, shorted or disconnected. (only during learning control, Auto tuning-2 or external sensor control)	ON	-	Operation continued under normal control	Restart the power supply
ERR19	AT Failure Occurs when auto tuning has not finished for 60min.	ON	-	Device stops	Restart the power supply
ERR21	Fan Alarm Occurs when cooling fan in the Temperature Controller is stopped. (Note 3)	ON	-	Device stops	Restart the power supply
ERR22	Leak Alarm Occurs when leak sensor in heat exchanger detects liquid leakage. (Note 3)	ON	-	Device stops	Restart the power supply

Note 1) The sensor which monitors the upper and lower limit alarm is the internal temperature sensor for “normal control” and the external sensor for “external sensor control” or “learning control” respectively.

Note 2) Internal sensor value for alarm is the value that fine control value is decreased from internal sensor value and offset value is not included The alarm is monitored by the internal temperature sensor for both the learning control and external sensor control.

$$\text{Internal sensor value set for alarm} = [\text{internal sensor value}] - [\text{Fine control value for internal sensor}]$$

Note 3) The remote OFF alarm, fan alarm and leak alarm can be monitored approx. 5 sec after the product is started.

6.4 Troubleshooting

Coping method of when the alarm occurs is explained as follows.

Table 6-3 Troubleshooting (1/2)

Alarm Code	Cause of alarm	Coping method
ERR00	High level noise entered the power line, ground line, or temp. sensor line.	Move the Chemical Thermo-con to an environment with little noise, turn ON the power supply. If there is no alarm, it causes from noise. Please consult with us.
ERR01	High level noise entered the power line, ground line, or temp. sensor line.	Move the Chemical Thermo-con to an environment with little noise, turn ON the power supply. If there is no alarm, it causes from noise. Please consult with us.
ERR03	The EEPROM data was destroyed by high level noise.	Move the Chemical Thermo-con to an environment with little noise, turn ON the power supply. If there is no alarm, it causes from noise. Please consult with us.
ERR04	Controller EEPROM data has been broken due to high level noise.	Restart the power supply. If the alarm cannot be reset even after that, reset data by turning on the power supply with the [SEL] and [RET] keys pressed. Request the repair if the alarm can't be reset.
ERR05	Writing frequency to EEPROM exceeds product guarantee value (1,000,000 times).	Restart the power supply. If the alarm cannot be reset even after that, reset data by turning on the power supply with the [SEL] and [RET] keys pressed. Request the repair if the alarm can't be reset.
ERR11	(1) DC output voltage of Thermo-con is decreased. (2) Voltage sag happens. (3) Peltier device is short-circuited.	(1) Check the power voltage 180 to 242VAC (2) If voltage sag lasts over specified value of 50msec, the output of DC power supply lowers and occurrence of alarm results. Supply the power to the extent so that such voltage sag will not happen. (3) Restart the power supply with DC cable disconnected. If the power supply can be restarted, assume that the Heat Exchanger is causing the problem.
ERR12	(1) Internal temp. sensor value exceeds the high temp. cutoff temperature. (2) Flow rate of recirculating fluid becomes zero.	(1) Check the set value for high temperature cutoff temperature and confirm the temperature really reaches abnormal value. (2) If flow rate of recirculating fluid becomes zero, the temperature of recirculating fluid can't be detected and might increase. Confirm the flow of recirculating fluid isn't prevented by valve etc.
ERR13	(1) Internal temp. sensor value becomes lower than low temp. cutoff temperature. (2) Flow rate of recirculating fluid becomes zero.	(1) Check the set value for low temp. cutoff temp. and confirm the temperature really reaches abnormal value. (2) If flow rate of recirculating fluid becomes zero, the temperature of recirculating fluid can't be detected and might decrease. Confirm the flow of recirculating fluid isn't prevented by valve etc.

Table 6-3 Troubleshooting (2/2)

Alarm Code	Cause of alarm	Coping method
ERR14	(1) Facility water temp is high or flow rate is not enough. (2) Flow rate of recirculating fluid is not enough. (3) Signal cable is not connected.	(1) Decrease facility water temp. and increase a flow rate. (2) If flow rate of recirculating fluid becomes zero, the temperature of recirculating fluid can't be detected and the temperature of Heat Exchanger might increase. Confirm the flow of recirculating fluid isn't prevented. (3) Check the connection of Signal cable.
ERR15	(1) Cooling or heating capacity over by loaded. (2) Capacity of recirculating fluid is too large.	(1) If PV temp. changes when the set temp. is raised and down, it causes overload. (2) If the capacity of recirculating fluid is too large, the change of temperature takes much time. In this case, provide setting which can prevent occurrence of alarm.
ERR17	(1) Internal temp. sensor is cutoff/short or not connected. (2) High level noise entered the temp. sensor line.	(1) Check the connection of Signal cable. (2) Check the temperature unstable occurred by noise. Please consult us if it causes noise.
ERR18	The external temp. sensor is not mounted.	For learning control or external tune control, be sure to mount the external temp. sensor.
ERR19	Capacity of recirculating fluid is too large.	Adjust PID value (proportional band, ARW value, integral time and derivative time) of setting mode Level 2 by hand.
ERR21	(1) The air inlet of Temperature Controller and the outlet opening is not enough (2) Fan is breaks.	(1) Places where there is a clearance of over 50mm in front of cooling fan and air inlet of temperature controller. (2) Request the repair if the alarm can't be reset.
ERR22	(1) Condensation has formed inside the Heat Exchanger (2) Fluid leakage occurs.	(1) Change the set temperature or perform purge (recirculating fluid or facility water) to keep the temperature above dew point. (2) Check whether fluid has got into the Heat Exchanger from outside. If the fluid is not coming from outside, replace the Heat Exchanger with a new one.
Temperature rises and falls +/-1 to 2 °C gradually about the set point temperature.	(1) Flow rate of recirculating fluid is a little. (2) PID parameters are wrong value.	(1) Increase a flow rate of recirculating fluid. (2) If the temperature can't be stable at default value, perform auto tuning.

Chapter 7 Communication

7.1 Preparation for Communication

Make preparation for using communication facility as follows.

- 1) Turn off the power switch of Chemical Thermo-con.
- 2) Connect communication cable to communication connector (RS-485 of RS-232C) of Chemical Thermo-con.
 - *Use twist pair shield cable as communication cable.
 - *Connect the host and Chemical Thermo-con with the cross cable for RS-232C and the straight cable for RS-485.
 - *Connect shielded cable of communication cable to communication connector and drop it to FG (flame ground).
 - *Connection drawing for communication is shown in the Fig. 7-1 and 7-2.
 - *Length of communication cable for RS-485 shall be limited to around 500[m] in total, and that for RS-232C shall be 15[m].
 - *If communication cable for RS-485 is longer, connect terminating resistance (220Ω, 1/2W) to each + and - terminal of the host computer and the farthest Chemical Thermo-con.
- 3) Turn on the power switch of Chemical Thermo-con.
- 4) Select communication types for all Chemical Thermo-cons. Refer to “5.5.5 setting mode level 3” for the details.
- 5) That’s all for preparation of communication. Then if a communication command from the host computer is given, each Chemical Thermo-con will reply it.

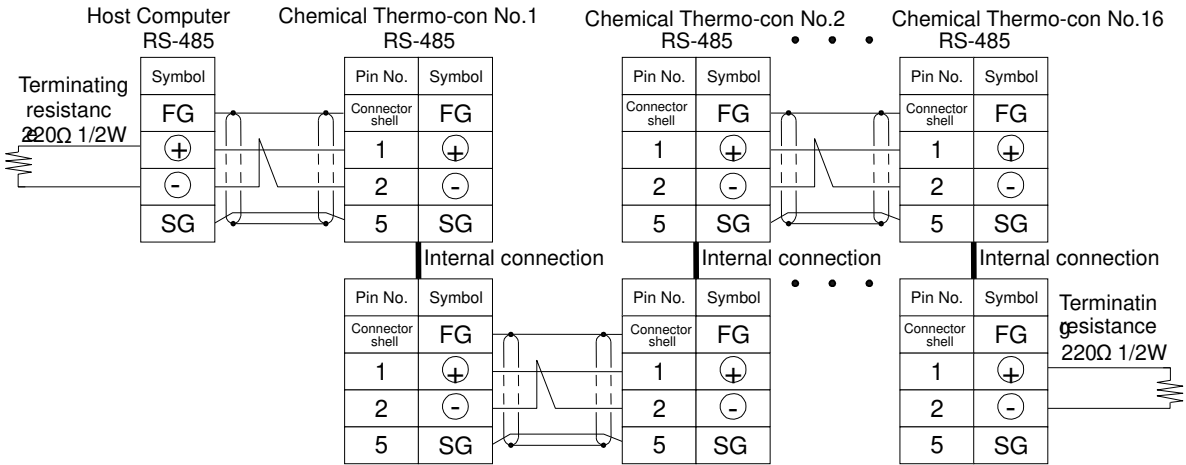

Fig. 7-1 Communication Connection (RS-485)

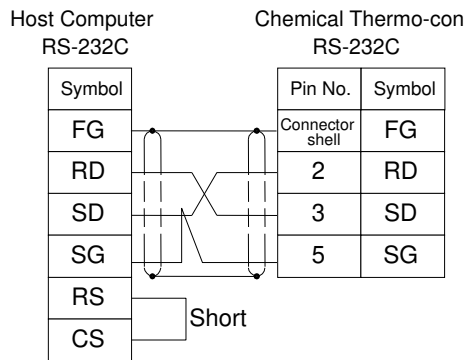

Fig. 7-2 Communication Connection (RS-232C)

7.2 Specifications of communication method

- *Standard ----- RS-485 or RS-232C
- *Circuit type ----- Half duplex
- *Communication type ----- Asynchronous
- *Communication speed ----- Changeable, 600,1200,2400,4800,9600,19200 bps
- *Character code ----- ASCII
- *Parity ----- Select, Nil, even number, odd number
- *Start bit ----- 1bit
- *Data length ----- Select 7 bit or 8 bit.
- *Stop bit ----- Select 1 bit or 2 bit.
- *Block check ----- Sum check

Note: Values underlined indicate default values at all reset.
 It is set to these values when delivered.

7.3 Communication format

7.3.1 Control code used for communication

Control code	ASCII code
ENQ	05H
STX	02H
ETX	03H
ACK	06H
CR	0DH
SOH	01H

* "H" of ASCII code indicates hexa code.

7.3.2 Command code list

Command code (COM)	Contents	Writing to EEPROM
31H	Setting and reading of target temp.	Not done
32H	Reading of current temp. with internal sensor	
33H	Reading of current temp. with external sensor	
34H	Reading of alarm status	
35H	Reading of temp. average data (It is same as reading external sensor in this model.)	
36H	Setting and reading of offset value	Not done
39H	Setting and reading of control operation mode	
41H	Setting and reading of PB range	
42H	Setting and reading of ARW range	
43H	Setting and reading of I constant	
44H	Setting and reading of D constant	
45H	Reading of output ratio	
46H	Setting and reading of heating power upper limit.	Not done
47H	Setting and reading of cooling power upper limit.	
48H	Saving of set values (transfer of all data from RAM to EEPROM)	Done

7.3.3 Communication procedures and format

The host computer has the initiative of sequence. Sequence always starts from the host computer and each Chemical Thermo-con replies it.

If communication data is processed normally, the Chemical Thermo-con returns specified response and if processing communication data is failed, no response is returned. When no response is returned to the host computer from the Chemical Thermo-con even if waiting for 3 sec., resend the data. The Chemical Thermo-con returns response after waiting for 50msec.

For communication of plural number of communication data, wait until the return message is received from the Chemical Thermo-con to send the next communication data. It sometimes cannot return the messages properly when the communication data is received successively.

Selection of Unit Specification

- *There are two cases in communication format, which are specifying unit No. and not.
- *When one Chemical Thermo-con is used, select "without specifying unit" and when two or more Chemical Thermo-cons are used, select "with specifying unit".
- *When several Chemical Thermo-cons are used with without specified unit No., correct control is not realized due to data conflict.
- *In the case of use with specified unit No., ensure to coincide communication No. and each Chemical Thermo-con unit No.

(1) Setting change

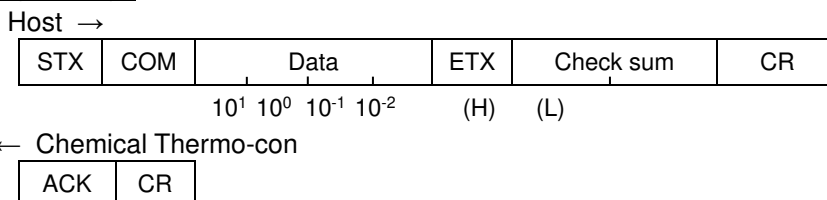

<Specifying unit>

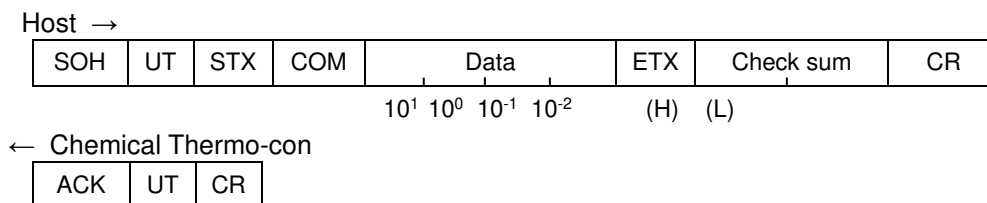

(2) Confirming and reading

Host →

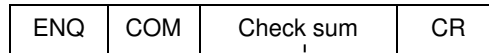

(H) (L)

← Chemical Thermo-con

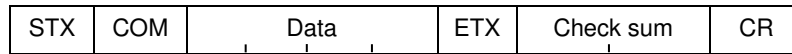

10¹ 10⁰ 10⁻¹ 10⁻² (H) (L)

Host →

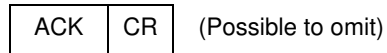

<Specifying unit>

Host →



(H) (L)

← Chemical Thermo-con

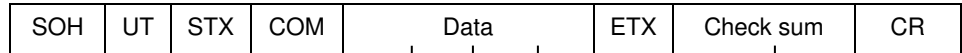

10¹ 10⁰ 10⁻¹ 10⁻² (H) (L)

Host →



*COM indicates communication command.

*UT indicates unit No. of each Chemical Thermo-con. Unit No. is the No. to identify each Chemical Thermo-con when 2 or more Chemical Thermo-cons are linked by communication. Set this No. with second mode of Chemical Thermo-con within 0 - F. (UT is the code adding 30H to unit No.. 30H---3FH.) As for symbols at communication, minus is indicated by "-" (2DH by ASCII code) and plus is indicated by "+" (30H by ASCII code).

*In case of setting temperature and offset with communication, data out of set range isn't memorized. (If communication format is correct, ACK returns.)

7.3.4 Calculation of Check Sum

Calculation range ----- From the second byte to ETX
 when there is no ETX, add before check sum.

Calculating method ----- Take out the lower 1 byte of the total.

eg.) Set temperature to 30°C (without unit specified)

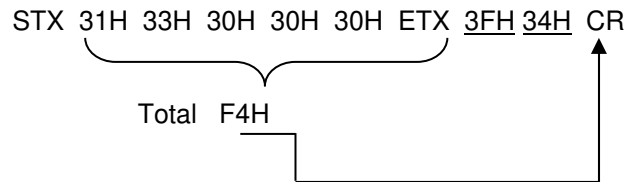

eg.) Read Chemical Thermo-con internal sensor of unit No.2

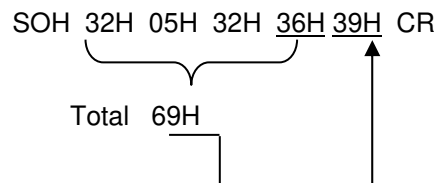

Note) Check sum is not ASCII code.

Data of UT and Check sum

Character data	0...9	A	B	C	D	E	F
ASCII	30H...39H	41H	42H	43H	44H	45H	46H
UT and Check sum	30H...39H(ditto)	3AH	3BH	3CH	3DH	3EH	3FH

7.4 Details of Communication Format

7.4.1 Setting of target temp. (without writing EEPROM)

The host computer sets target temperature of each Chemical Thermo-con. In this command, temperature setting data is not written in EEPROM. This data is invalidated by turning off power.

The setting range is from 10.0 to 60.0°C. As 0.1°C is the minimum unit, the number in the hundredths place (10^{-2}) should always be 0 (=30H). (When the value at every 0.01°C is input, it is rounded off.)

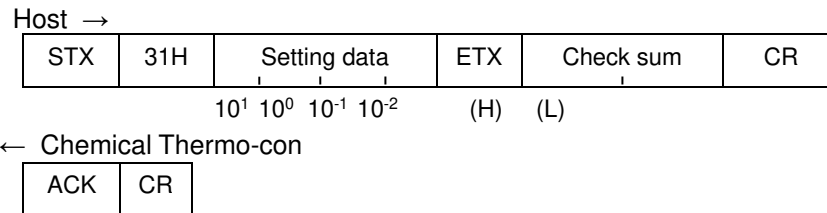

<Specifying unit>

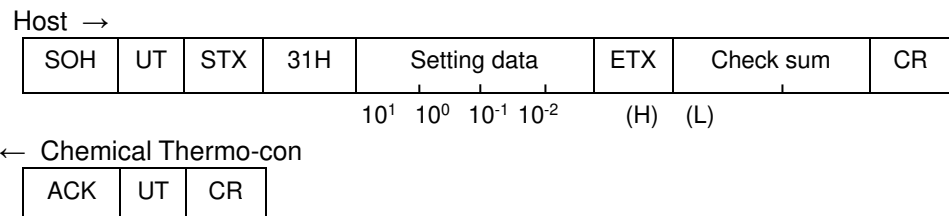

7.4.2 Reading of target temp.

As 0.1°C is the minimum unit, the number in the hundredths place (10^{-2}) is always 0 (=30H).

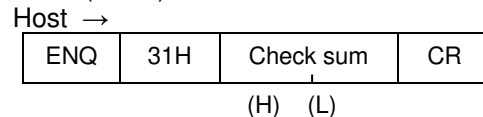

← Chemical Thermo-con

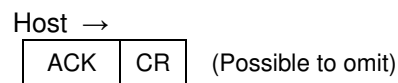
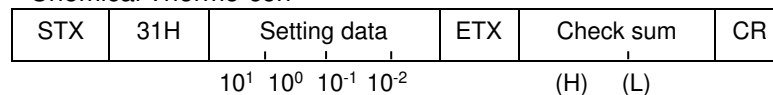

<Specifying unit>

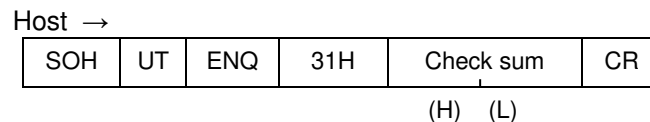

← Chemical Thermo-con

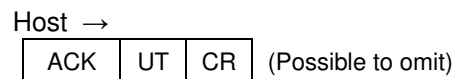
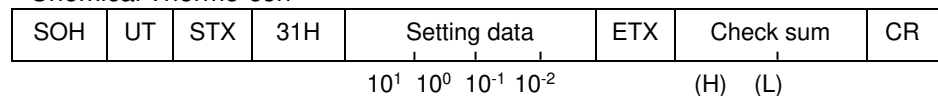

7.4.3 Reading of current temp. with internal sensor

As the minimum unit is 0.01°C, the value in the hundredths place can be read.

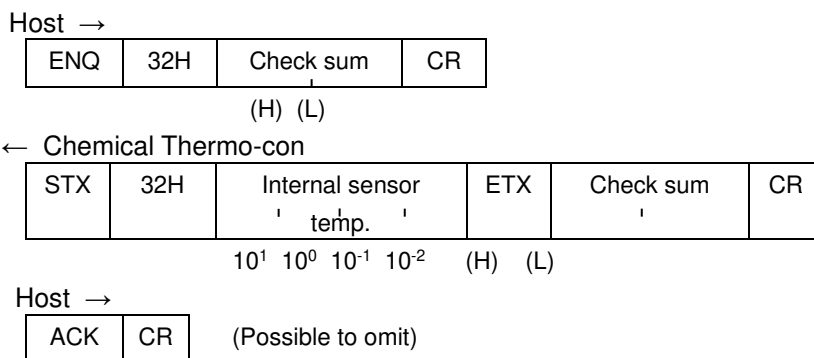

Note) 2DH is entered in 10^1 digit "-" is attached to temperature data.

<Specifying unit>

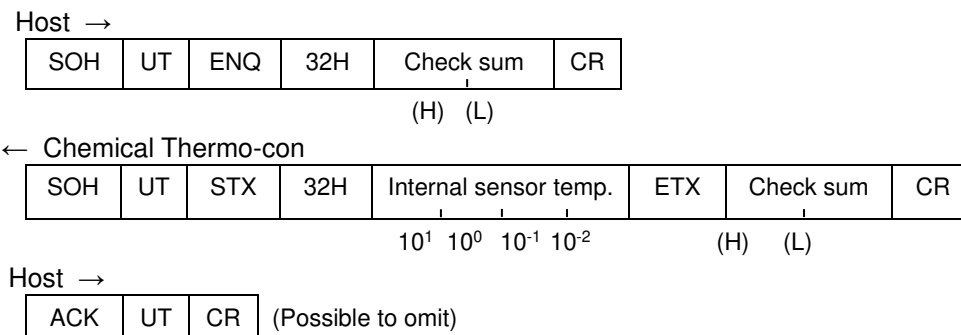

Note) 2DH is entered in 10^1 digit "-" is attached to temperature data.

7.4.4 Reading of current temp. with external sensor

As the minimum unit is 0.01°C, the value in the hundredths place can be read.

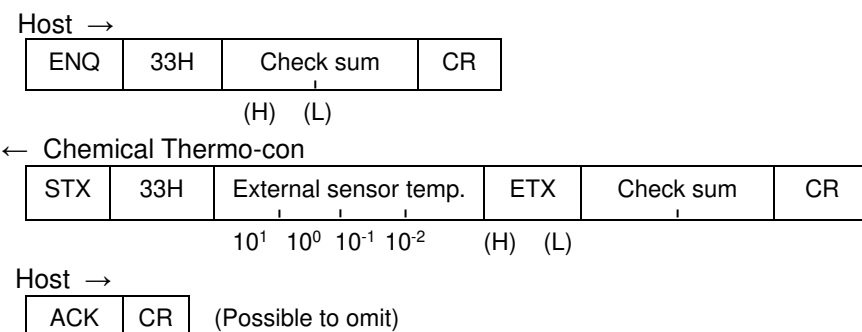

Note) 2DH is entered in 10^1 digit "-" is attached to temperature data.

<Specifying unit>

Host →

SOH	UT	ENQ	33H	Check sum	CR
-----	----	-----	-----	-----------	----

(H) (L)

← Chemical Thermo-con

SOH	UT	STX	33H	External sensor temp.	ETX	Check sum	CR
-----	----	-----	-----	-----------------------	-----	-----------	----

10¹ 10⁰ 10⁻¹ 10⁻²

(H) (L)

Host →

ACK	UT	CR
-----	----	----

(Possible to omit)

Note) 2DH is entered in 10¹ digit “-“ is attached to temperature data.

7.4.5 Reading of alarm status

Host →

ENQ	34H	Check sum	CR
-----	-----	-----------	----

(H) (L)

← Chemical Thermo-con

STX	34H	Data	ETX	Check sum	CR
-----	-----	------	-----	-----------	----

D1 D2 D3

(H) (L)

Host →

ACK	CR
-----	----

(Possible to omit)

<Specifying unit>

Host →

SOH	UT	ENQ	34H	Check sum	CR
-----	----	-----	-----	-----------	----

(H) (L)

← Chemical Thermo-con

SOH	UT	STX	34H	Data	ETX	Check sum	CR
-----	----	-----	-----	------	-----	-----------	----

D1 D2 D3 (H) (L)

Host →

ACK	UT	CR
-----	----	----

(Possible to omit)

Data (D2, D2, D3) changes following bit line to ASCII code.
 (1 is for ON, 0 is for OFF)

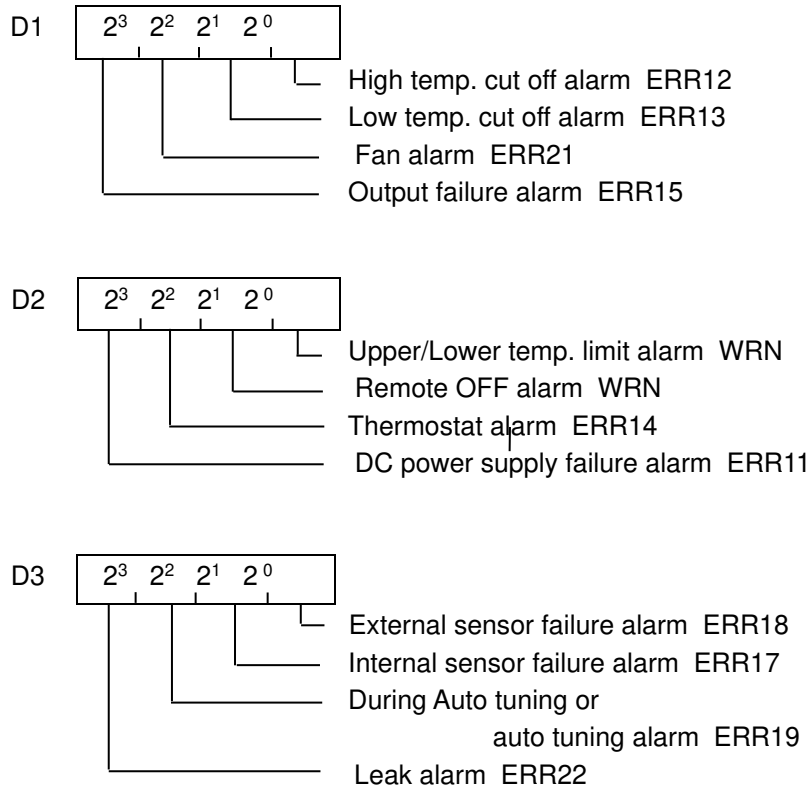

When some alarms/warnings go off at the same time, D1 to D3 reaches the added value.

Ex. When the “Upper temperature limit alarm” and the “DC power voltage alarm” go off simultaneously,

D2 will be $2^3 \times 1 + 2^2 \times 0 + 2^1 \times 0 + 2^0 \times 1 = 9 (=39H)$.

ERR19 becomes common status of AT1 and AT2.

7.4.6 Reading of temp. average data

Note) For this product, the average temperature data, Tm, indicates the temperature of the external sensor. Refer to “7.4.4 Reading of current temp. with external sensor” for the format.

7.4.7 Setting of offset value (without writing EEPROM)

The host computer sets offset value of each Chemical Thermo-con. In this command, offset value data is not written in EEPROM. This data is invalidated by turning off power.

It can be set at a minimum of every 0.01°C.

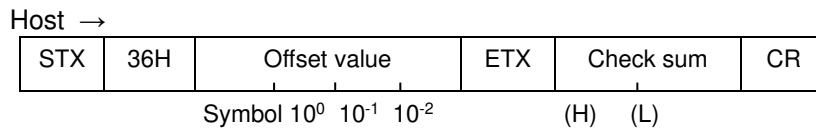

← Chemical Thermo-con

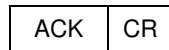

Note) As for symbols, minus is indicated by “-“(=2DH) and plus is indicated by “0“(=30H).

<Specifying unit>

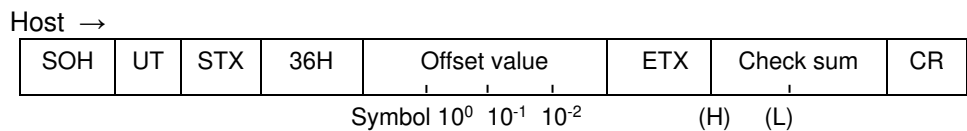

← Chemical Thermo-con

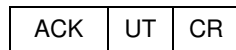

Note) As for symbols, minus is indicated by “-“(=2DH) and plus is indicated by “0“(=30H).

7.4.8 Reading of offset value

As the minimum unit is 0.01°C, the value in the hundredths place can be read.

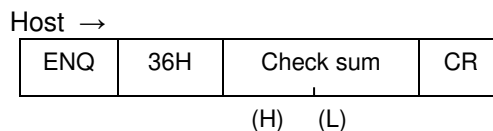

← Chemical Thermo-con

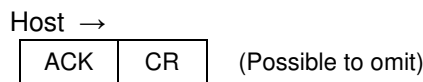
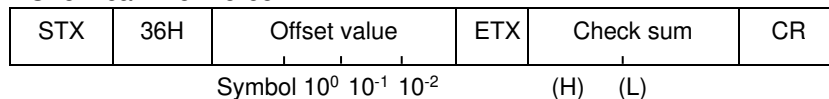

Note) As for symbols, minus is indicated by “-“(=2DH) and plus is indicated by “0“(=30H).

<Specifying unit>

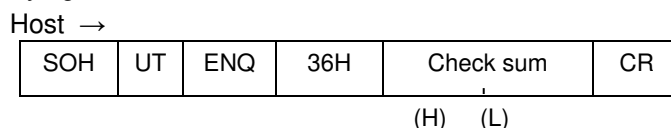

← Chemical Thermo-con

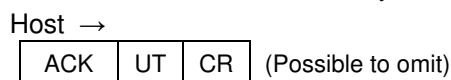
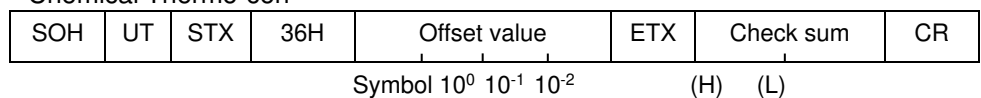

Note) As for symbols, minus is indicated by “-“(=2DH) and plus is indicated by “0“(=30H).

7.4.9 Setting of control operation mode (without writing EEPROM)

The host computer sets control operation of each Chemical Thermo-con. In this command, control operation data is not written in EEPROM. This data is invalidated by turning off power.

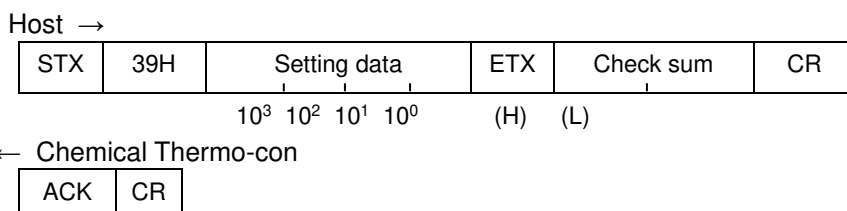

<Specifying unit>

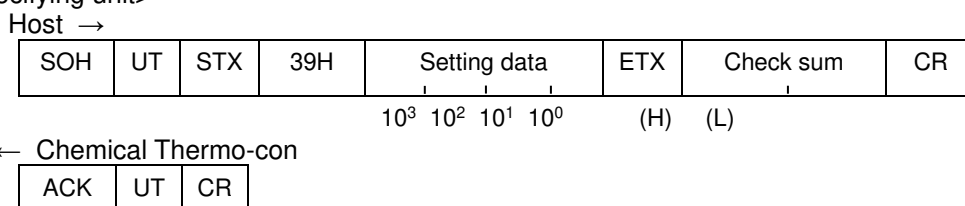

Note) The setting range is from 0000 to 0005.

7.4.10 Reading of control operation mode

The host computer reads control operation of each Chemical Thermo-con.

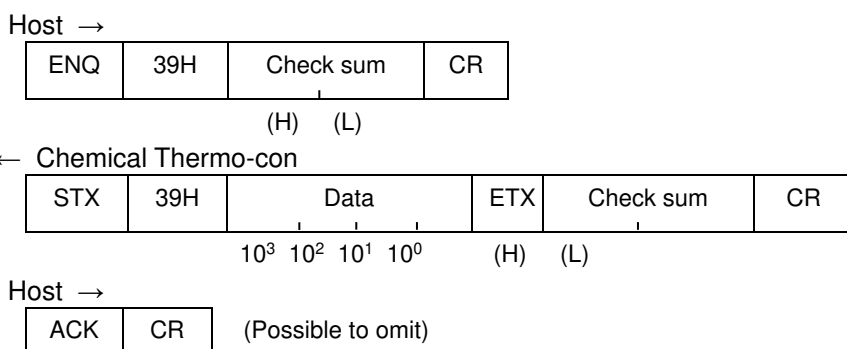

<Specifying unit>

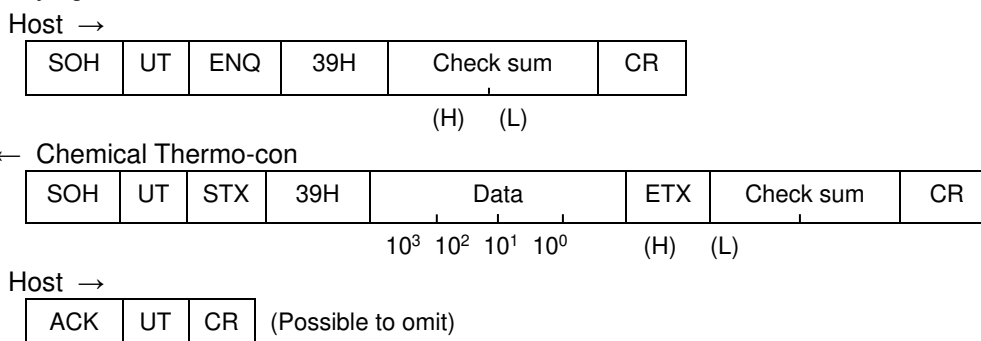

7.4.11 Setting of PB range (without writing EEPROM)

The host computer sets PB range of each Chemical Thermo-con. In this command, PB range data is not written in EEPROM. This data is invalidated by turning off power.

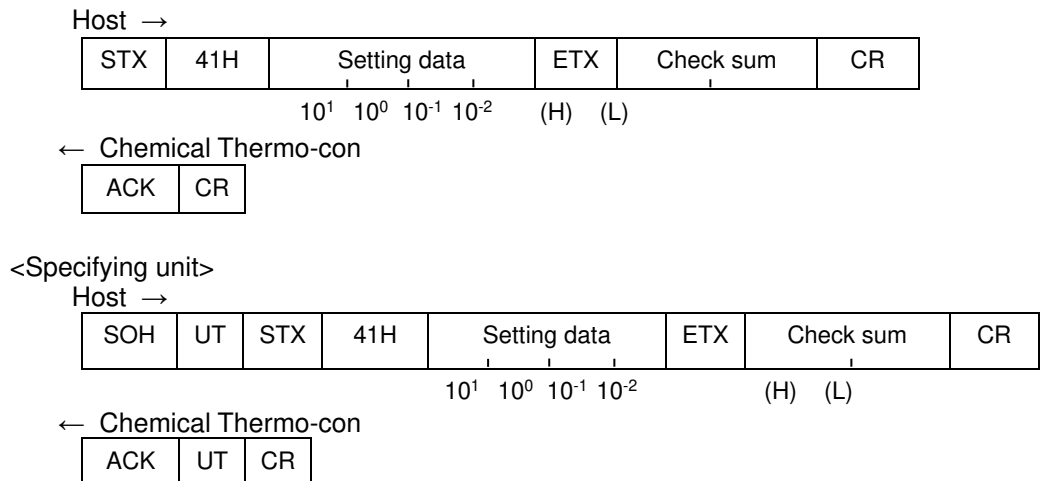

Note) The setting range is from 00.30 to 09.90°C. As 0.1°C is the minimum unit, the number in the hundredths place (10⁻²) should always be 0 (=30H). (When the value at every 0.01°C is input, it is rounded off.)

7.4.12 Reading of PB range

The host computer reads PB range of each Chemical Thermo-con.

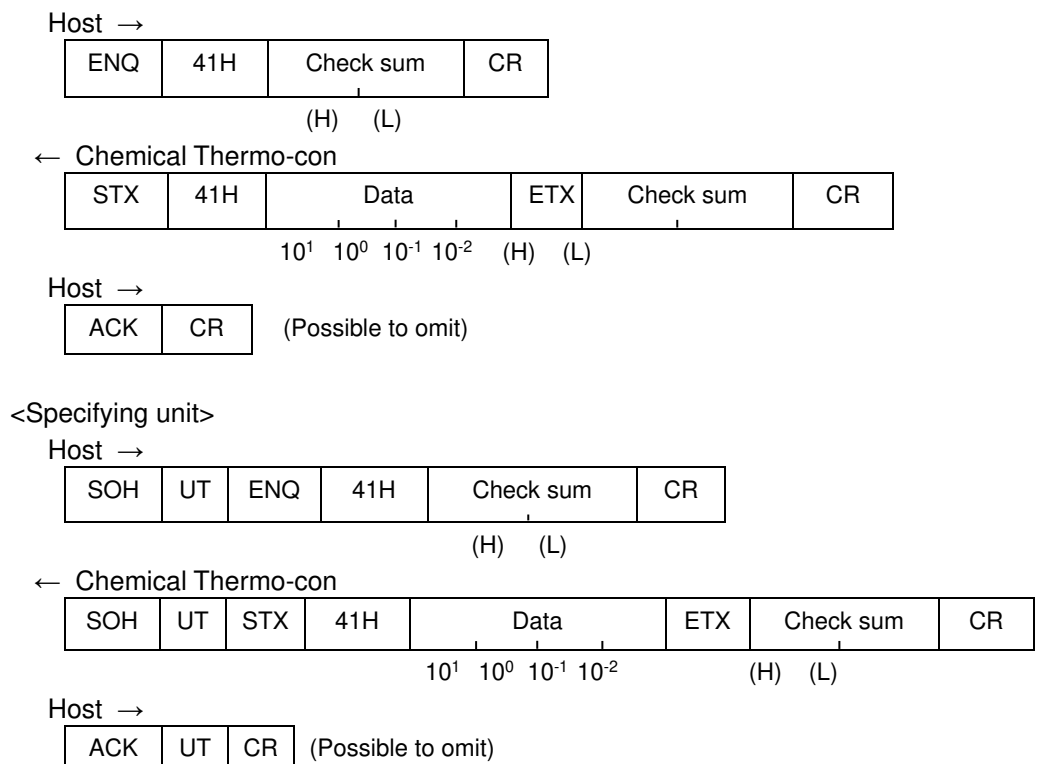

Note) As 0.1°C is the minimum unit, the number in the hundredths place (10⁻²) is always 0 (=30H).

7.4.13 Setting of ARW range (without writing EEPROM)

The host computer sets ARW range of each Chemical Thermo-con. In this command, ARW range data is not written in EEPROM. This data is invalidated by turning off power.

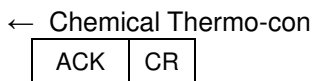
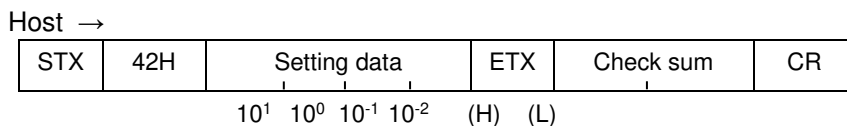

<Specifying unit>

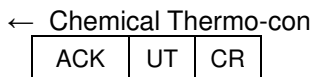
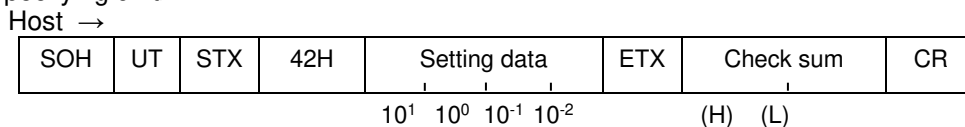

Note) The setting range is from 00.30 to 09.90°C. As 0.1°C is the minimum unit, the number in the hundredths place (10⁻²) should always be 0 (=30H). (When the value at every 0.01°C is input, it is rounded off.)

7.4.14 Reading of ARW range

The host computer reads ARW range of each Chemical Thermo-con.

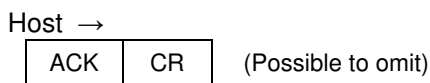
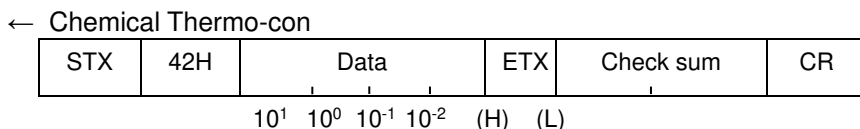
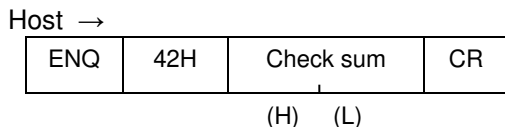

<Specifying unit>

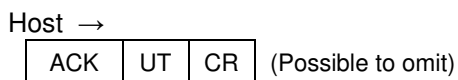
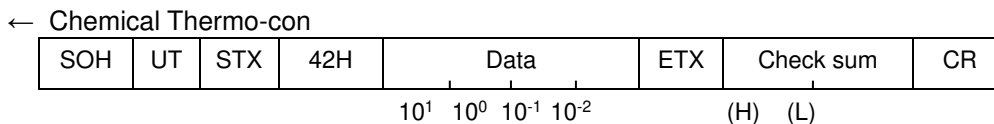
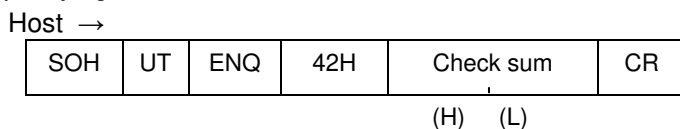

Note) As 0.1°C is the minimum unit, the number in the hundredths place (10⁻²) is always 0 (=30H).

7.4.15 Setting of I constant (without writing EEPROM)

The host computer sets I constant of each Chemical Thermo-con. In this command, I constant data is not written in EEPROM. This data is invalidated by turning off power.

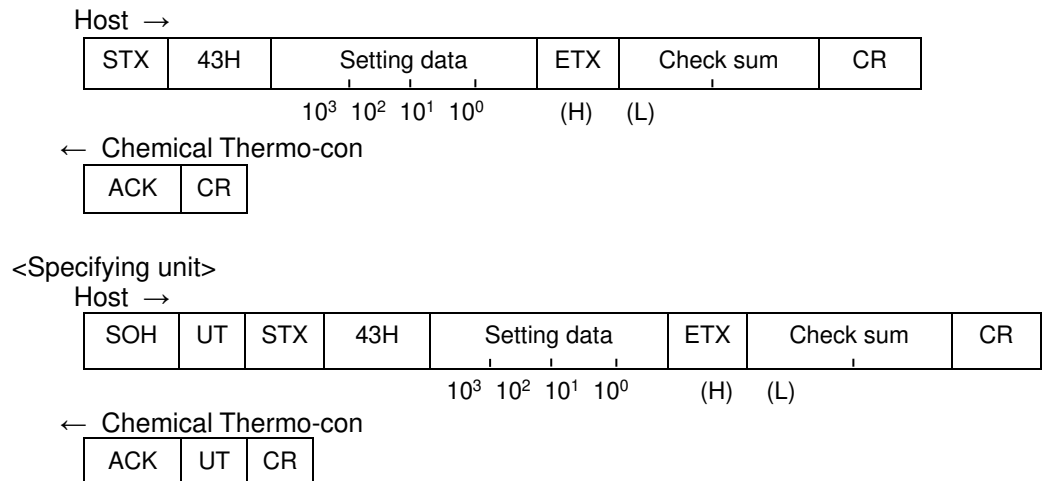

Note) The setting range is from 0001 to 0009 sec.

7.4.16 Reading of I constant

The host computer reads I constant of each Chemical Thermo-con.

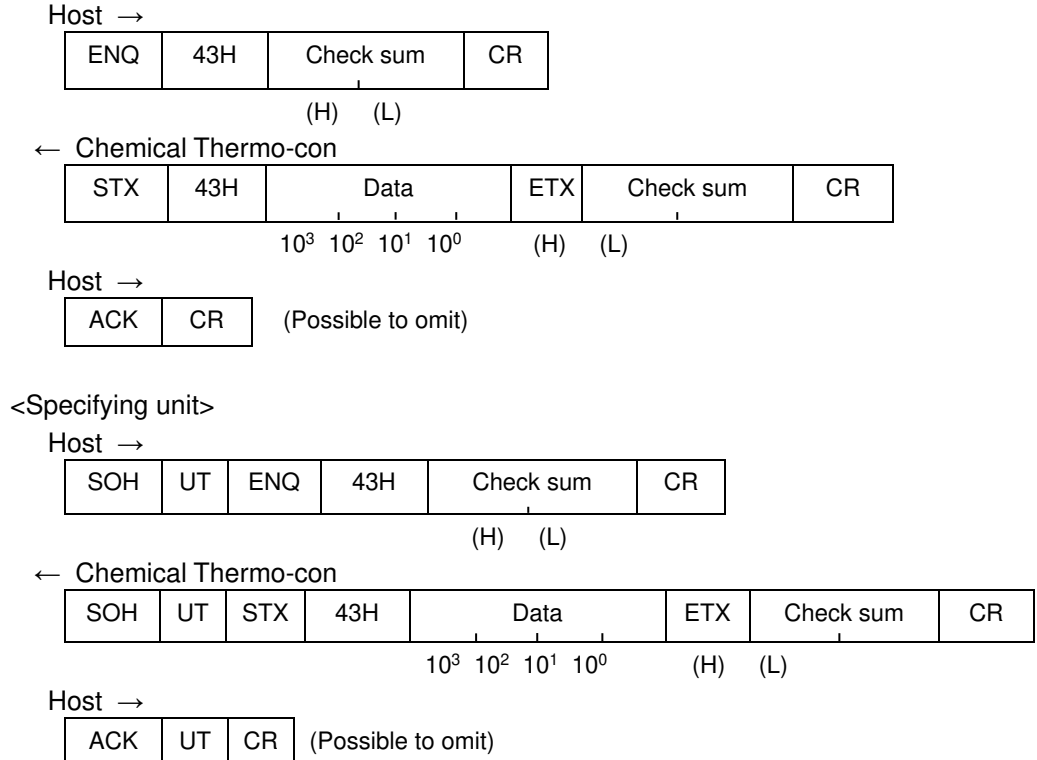

7.4.17 Setting of D constant (without writing EEPROM)

The host computer sets D constant of each Chemical Thermo-con. In this command, D constant data is not written in EEPROM. This data is invalidated by turning off power.

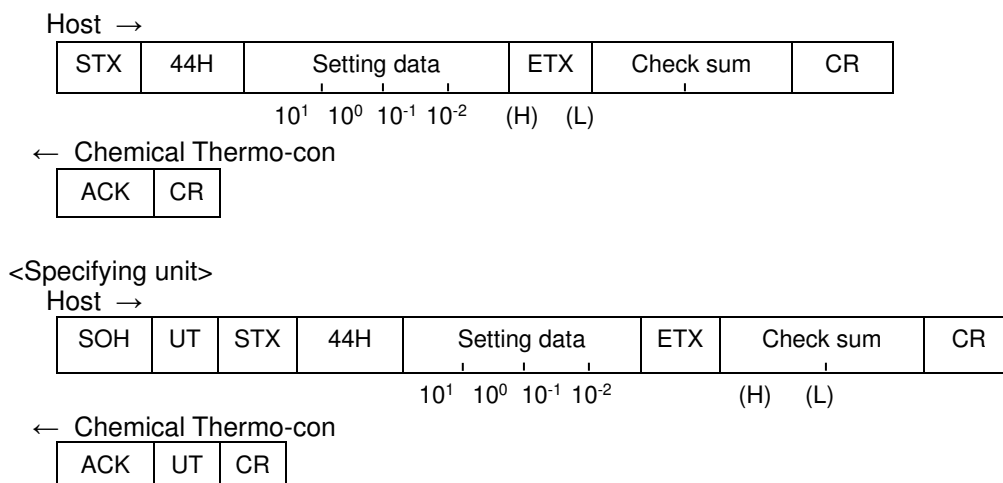

Note) The setting range is from 00.00 to 99.90sec. As 0.1sec is the minimum unit, the number in the hundredths place (10^{-2}) should always be 0 (=30H). (When the value at every 0.01sec is input, it is rounded off.)

7.4.18 Reading of D constant

The host computer reads D constant of each Chemical Thermo-con.

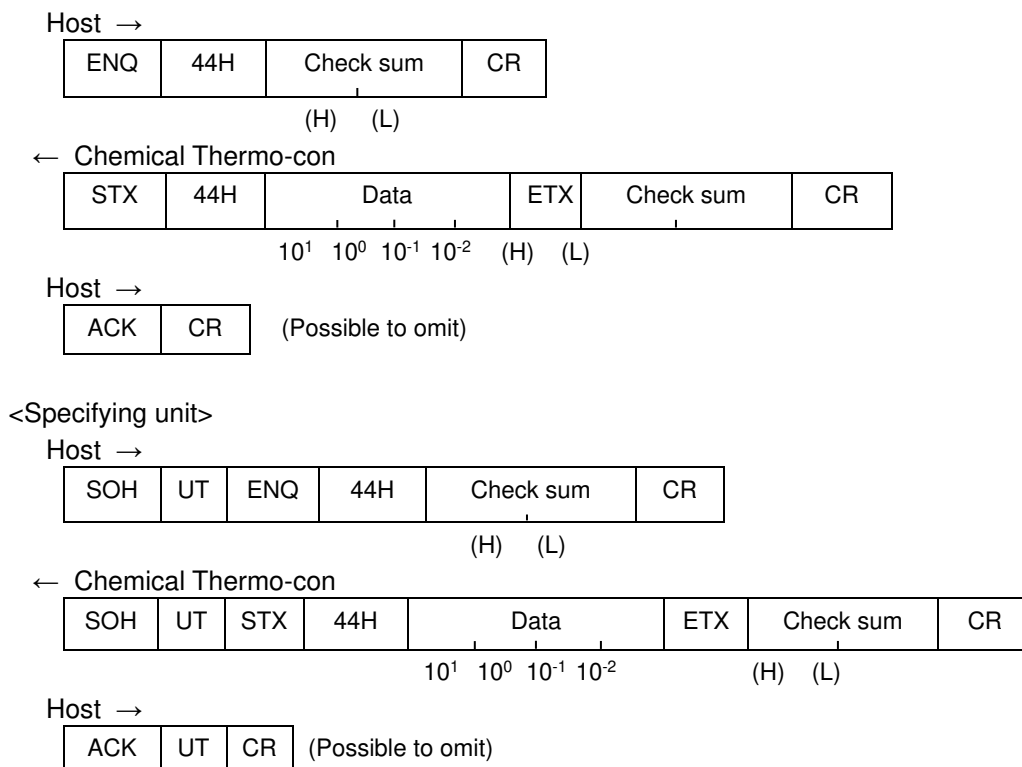

Note) As 0.1°C is the minimum unit, the number in the hundredths place (10^{-2}) is always 0 (=30H).

7.4.19 Reading of output ratio

The host computer read output ratio of each Chemical Thermo-con.

Host →

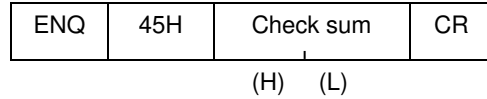

← Chemical Thermo-con

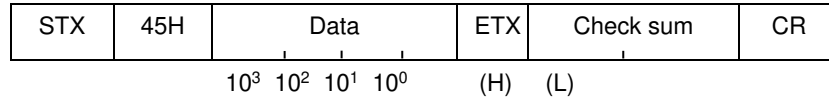

Host →

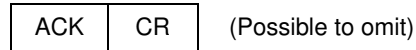

<Specifying unit>

Host →

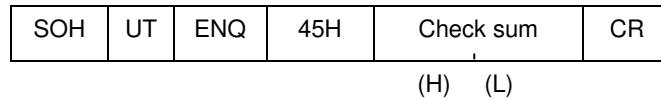

← Chemical Thermo-con

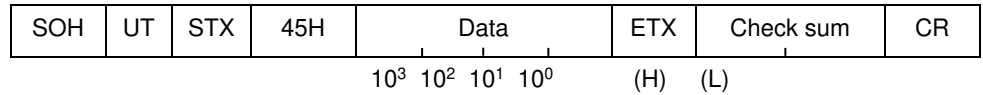

Host →



Note) Output ratio from -100 to 0100% is read.

As for 10³ digit, minus is indicated by "-"(=2DH) and plus is indicated by "0"(=30H).

7.4.20 Setting of heating power upper limit value (without writing EEPROM)

The host computer sets heating power upper limit value of each Chemical Thermo-con. In this command, heating upper limit value data is not written in EEPROM. This data is invalidated by turning off power.

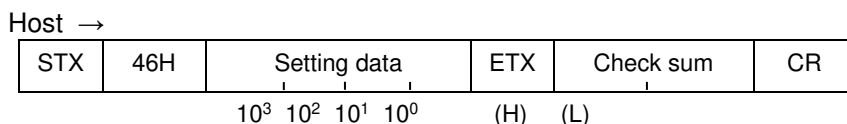

← Chemical Thermo-con

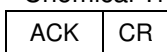

<Specifying unit>

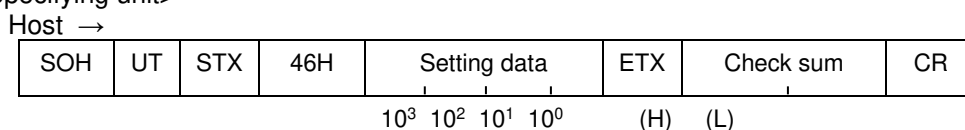

← Chemical Thermo-con

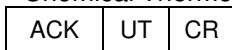

Note) The setting range is from 0000 to 0100%.

7.4.21 Reading of heating power upper limit value

The host computer reads heating power upper limit value of each Chemical Thermo-con.

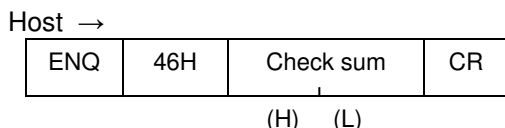

← Chemical Thermo-con

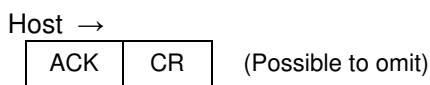
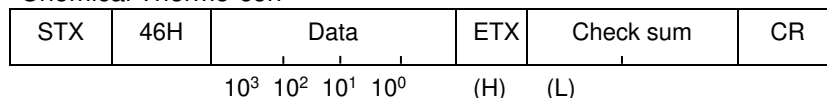

<Specifying unit>

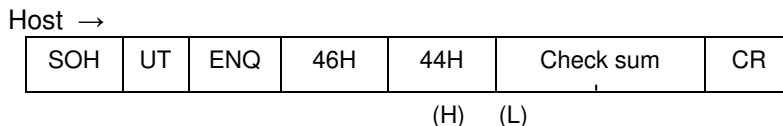

← Chemical Thermo-con

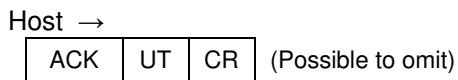
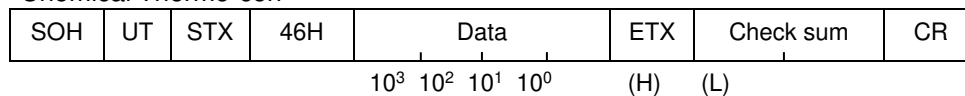

7.4.22 Setting of cooling power upper limit value (without writing EEPROM)

The host computer sets cooling power upper limit value of each Chemical Thermo-con. In this command, cooling power upper limit data is not written in EEPROM. This data is invalidated by turning off power.

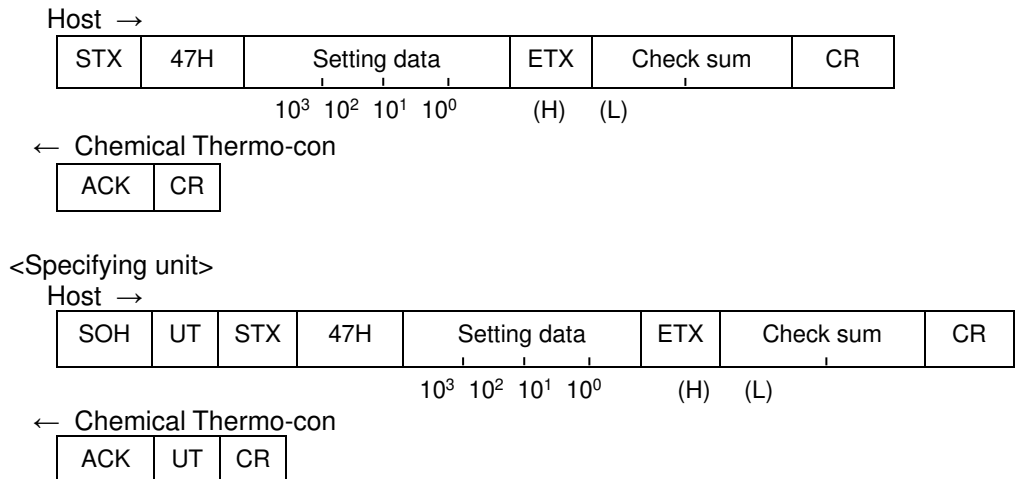

Note) The setting range is from -100 to 0000%.

As for 10³ digit, minus is indicated by “-”(=2DH) and plus is indicated by “0”(=30H)

7.4.23 Reading of cooling power upper limit value

The host computer reads cooling power upper limit value of each Chemical Thermo-con.

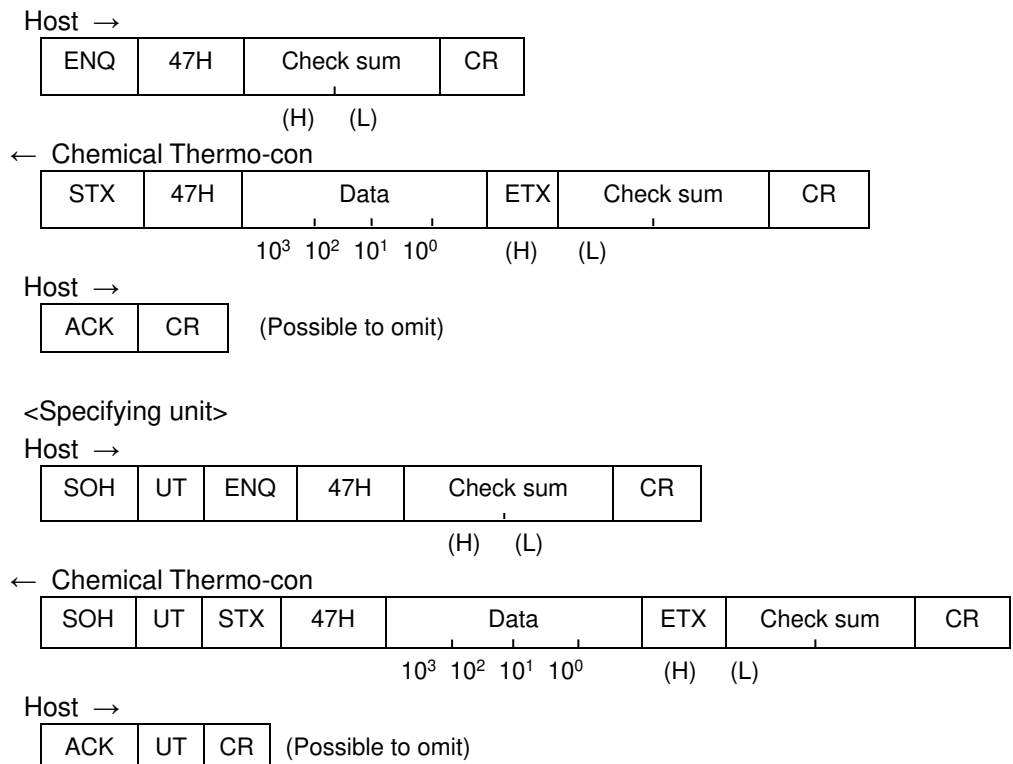

7.4.24 Saving of set values

(Transfer of all data from RAM to EEPROM)

The host computer transmits all data from RAM to EEPROM of the product.
In this command, the data is written into EEPROM and retained when the power supply is turned off.

Host →

STX	48H	ETX	Check sum	CR
-----	-----	-----	-----------	----

(H) (L)

← Chemical Thermo-con

ACK	CR
-----	----

<Specifying unit>

Host →

SOH	UT	STX	48H	ETX	Check sum	CR
-----	----	-----	-----	-----	-----------	----

(H) (L)

← Chemical Thermo-con

ACK	UT	CR
-----	----	----

Chapter 8 Check • Repair

The following checks shall be performed before operation.

8.1 Daily check

Check the following items at least once a month. The inspection must be done by an operator who has sufficient knowledge and experience.

- 1) Indication of display panel: Check temperature condition and confirm whether or not the alarm occurs.
- 2) Check the recirculating fluid is not contaminated. Once the fluid is contaminated, it may degrade the performance or shorten the life time.
- 3) Check whether is leakage of recirculating fluid or facility water, the piping is bent or collapsed, or the filter is clogged, resulting in the decrease of recirculating fluid flow rate or the increase of the internal pressure in the recirculating fluid path. If any of these is found, it can cause impaired performance or shortened product life.
- 4) Confirm there is no abnormal sound or smell or abnormal heating of the case.

8.2 Check after seismic vibration and impact

- 1) Piping: Confirm there is no defect including disconnection in piping.
- 2) Electrical wiring: Confirm there is disconnection of the connector from the cable.
- 3) Mounting condition: If the Chemical Thermo-con is mounted for operation, confirm the Chemical Thermo-con is mounted securely.
- 4) Recirculating fluid and facility water: Confirm there is no leakage.
- 5) Others: Confirm there is no abnormal sound or smell or abnormal heating of the case.

8.3 Repair and maintenance

The preparation of a backup product is recommended to minimize downtime of the customer's system.

8.3.1 Heat Exchanger

As a rule, repair of the Heat Exchanger will not be undertaken. (Including trips to the customer for repair.)

Only the return of the Heat Exchanger for investigation within the warranty period can be accepted. Before returning the product to SMC for repair or maintenance, it is the customer's responsibility to drain the chemical from the Heat Exchanger, clean it with appropriate neutralizer and dry it.

WARNING



- **Before returning the product to SMC for repair or maintenance, drain chemical in the Heat Exchanger, clean it with appropriate neutralizer and dry it on the customer's own responsibility. Any liquid left in the product could cause damage to the equipment during transportation.**

8.3.2 Temperature Controller

Maintenance of the Temperature Controller is performed only in the form of return to or repair at SMC's factory. As a rule, we will not undertake trips to the customer for maintenance.

Separately, the following parts need to be replaced on a regular basis, and other parts should be also checked periodically. For replacement, return the part to SMC.

Regular service parts

- 1) Part: FAN
Capable life: 5 to 10 years
Failure conditions: The capacity of the fan lowers due to the end of lubricating performance of the bearing, which results in an increase in internal temperature of the product. The overheat protection circuit in the power supply operates and DC power supply failure alarm is generated.
How to replace: Replacement of FAN (requiring return to SMC)
- 2) Part: DC power supply
Capable life: 5 to 10 years
Failure conditions: The capacity of the electrolytic capacitor lowers, which generates abnormal voltage and DC power supply failure alarm. The product is stopped.
How to replace: Replacement of DC power supply (requiring return to SMC)
- 3) Part: Display
Capable life: 50,000 hours (approx. 5 years, 25±10°C, 65%RH or less)
Failure conditions: The LCD back light comes to the end of its life, which turns off the display.
How to replace: Replacement of LCD unit (requiring return to SMC)

WARNING



- **Contact the sales distributor or branch for replacement.**
- **Do not disassemble or retrofit this product. A product repaired by the user cannot be guaranteed and carries the danger of causing electrical shock and other accidents.**

Chapter 9 Appendix

9.1 How to order and manufacturing code indication

9.1.1 How to order

1) How to order a set (Part number for a set of Temperature Controller and Heat Exchanger)

Note) This is the part number to order the Temperature Controller and Heat Exchanger as a set.

The model label of the product will have the part number of the Temperature Controller and Heat Exchanger shown respectively.

HED009- W 2 A 25 - *

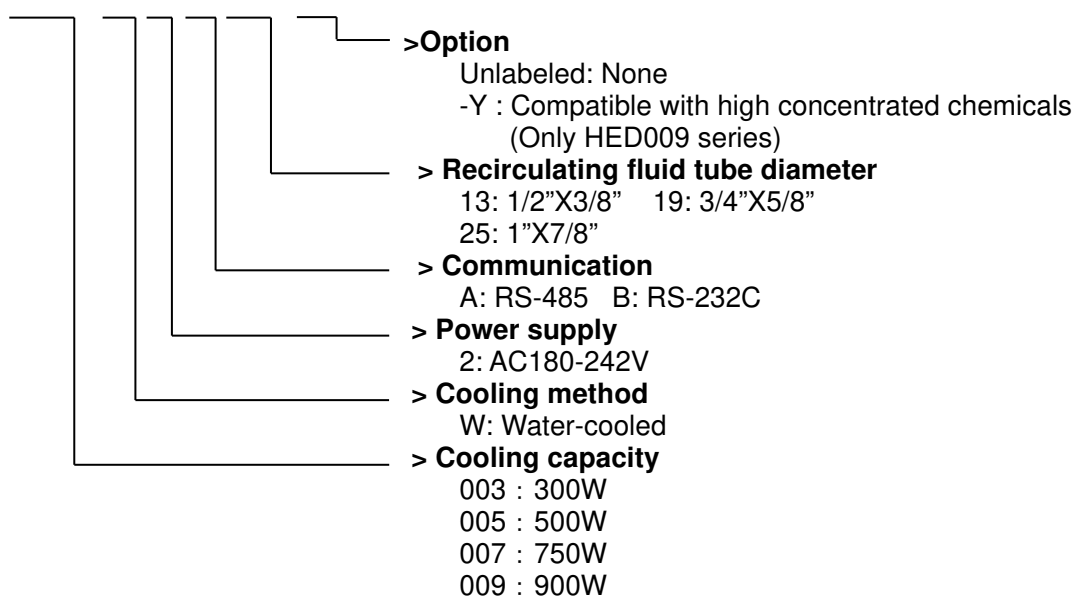

Table 9-1 Combination in set

Series	Part no. for set	Part no. for Heat Exchanger	Part no. for Temp. Controller
HED003 Series	HED003-W2A13	HED003-HW13	HED003-C2A
	HED003-W2A19	HED003-HW19	
	HED003-W2B13	HED003-HW13	HED003-C2B
	HED003-W2B19	HED003-HW19	
HED005 Series	HED005-W2A13	HED005-HW13	HED005-C2A
	HED005-W2A19	HED005-HW19	
	HED005-W2B13	HED005-HW13	HED005-C2B
	HED005-W2B19	HED005-HW19	
HED007 Series	HED007-W2A13	HED007-HW13	HED007-C2A
	HED007-W2A19	HED007-HW19	
	HED007-W2B13	HED007-HW13	HED007-C2B
	HED007-W2B19	HED007-HW19	
HED009 Series	HED009-W2A19	HED009-HW25	HED009-C2A
	HED009-W2B19	HED009-HW25	HED009-C2B

2) How to order an individual product

Temperature Controller

H E D 0 0 9 – C 2 A

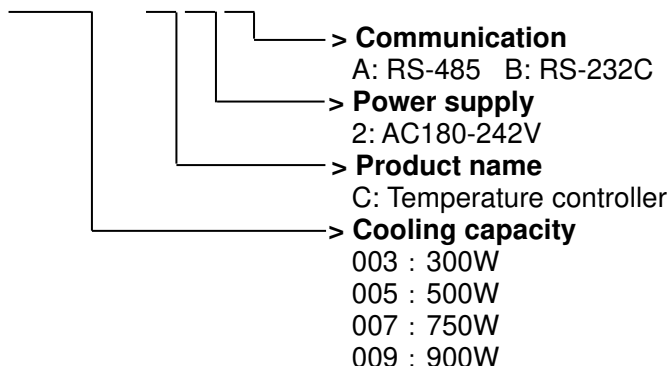

Heat Exchanger

H E D 0 0 9 – H W 2 5 – *

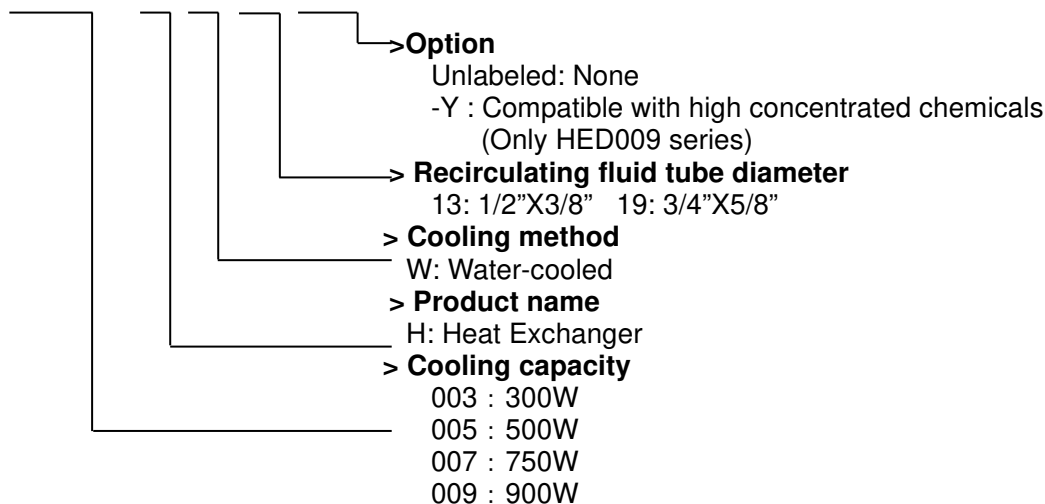

9.1.2 Manufacturing code indication

SERIAL No. C o – 0 0 0 1

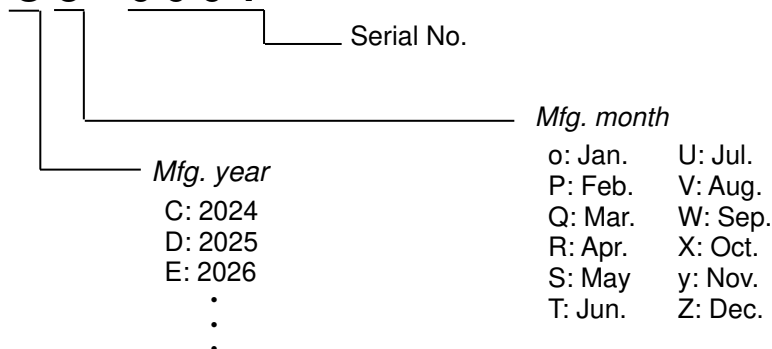

9.2 Specifications

9.2.1 Specification table

Table 9-2 Temperature Controller

Part No.	HED003		HED005		HED007		HED009	
	-C2A	-C2B	-C2A	-C2B	-C2A	-C2B	-C2A	-C2B
Communication	RS-485	RS-232C	RS-485	RS-232C	RS-485	RS-232C	RS-485	RS-232C
Operating temp. range	10.0 to 60.0°C (temp. outside of this range can not be set)							
Indicating temp. range	-9.9 to 80.0°C (temp. outside of this range is not indicated)							
Indication accuracy	Within $\pm 0.3^{\circ}\text{C}$ (not including sensor accuracy)							
Temp. drift	Within $\pm 0.2^{\circ}\text{C}$ (at ambient temp. 15 to 35°C)							
Temp. stability(Note 1)	Within $\pm 0.1^{\circ}\text{C}$ (with stable load)							
Power supply	AC180-242V, Single phase, 50/60Hz, 3Amax		AC180-242V, Single phase, 50/60Hz, 5Amax		AC180-242V, Single phase, 50/60Hz, 14Amax			
Over current protection	Circuit protector 7.5A		Circuit protector 7.5A		Circuit protector 20A			
Output to Peltier device	DC $\pm 48\text{V}\pm 10\%$, 8A		DC $\pm 48\text{V}\pm 10\%$, 13A		DC $\pm 48\text{V}\pm 10\%$, 12A			
Main functions	Auto tuning, Offset, Learning control, External sensor control, Sensor fine adjustment, Memorization of set value, Temp. upper/lower limit alarm, Serial communication, Output cut-off alarm, Remote ON/OFF, Liquid leakage detection							
Input operation	Membrane key sheet							
Indication	LCD panel (with a back light)							
Alarm contact output	Output cutoff alarm, Temp upper/lower limit alarm Relay output : C contact 0.3 A at 125VAC, 2 A at 30VDC (at resistive load)							
Temp. sensor (Note 2)	Resistance thermometer sensor, Pt100 Ω , Class A, 2mA, 3-Connecting wire, JIS C 1604 (Internal temp. sensor, External temp. sensor)							
Ambient temp. /humidity	10-35°C, 35 to 80%RH (no condensation)							
Ambient air quality	Appropriate environment with no corrosive gas, solvents such as thinner, dust or combustible gas.							
Power interruption	50ms or less							
Insulation resistance	50M Ω or more (for removal of surge absorber)							
Noise resistance	2000V in both normal and common modes (1 μ s width impulse noise)							
Electrostatic discharge resistance	Voltage discharged to body: 8kV or less (Air discharge)							
Dimensions (Note 3)	W100xD320 xH215mm		W140xD350 xH215mm		W165x D447xH215mm			
Paint color	White		White		White			
Weight	Approx. 6kg		Approx. 8kg		Approx. 13kg			
Accessory	Power supply cable: 2m (AWG14, Diameter: $\phi 8.4$)				Power supply cable: 2m (AWG12, Diameter: $\phi 11.8$)			
Connected Heat Exchanger (Note 4)	HED003-HW13 HED003-HW19		HED005-HW13 HED005-HW19		HED007-HW13 HED007-HW19		HED009-HW25	

Note 1) This value is with a stable load with no disturbance.

This value cannot be achieved in some operating conditions.

Note 2) The external temperature sensor should be prepared by the customer.

Note 3) The dimensions do not include protruding parts such as the foot flange, screw and connector.

Note 4) The Temperature Controller shall be connected with a specific series of Heat Exchanger. If connected with a different series of Heat Exchanger, normal operation may not be obtained. (The HED003 and HED005 series, HED007 and HED009 series use the same connector, so there is no need to be concerned about incorrect wiring.)

Table 9-3. Heat Exchanger

Part No.	HED003		HED005		HED007		HED009
	-HW13	-HW19	-HW13	-HW19	-HW13	-HW19	-HW25
Cooling capacity (Note 5)	300W		500W		750W		900W
Heating capacity (Note 5)	600W		1000W		1800W		2300W
Cooling/Heating method	Peltier device (Thermoelectric device, Thermo-module)						
Cooling method	Water-cooled						
Operating temp. range	10.0 to 60.0°C (depending on recirculating fluid) (no condensation)						
Recirculating fluid tube diameter	1/2"x3/8"	3/4"x5/8"	1/2"x3/8"	3/4"x5/8"	1/2"x3/8"	3/4"x5/8"	1"x7/8"
Recirculating fluid (Note 6,7,8)	Pure water, Hydrofluoric acid, Ammonia hydrogen peroxide solution etc.						
Recirculating fluid operating pressure	0 (Atmospheric pressure) to 0.35MPa (Note 9)						0 (Atmospheric pressure) to 0.35MPa (0.5MPa,Note10)
Flow rate	7 to 17 L/min						
Facility water tube diameter	3/8"x1/4"						
Facility water (Note 11)	Flow rate: 5 to 10 L/min , Temp.: 10 to 35°C (no condensation) Max. operating pressure: 0.5MPa						
Wetted materials	Recirculating	PFA					PFA, SiC
	Facility	FEP, SUS304, SUS316					
Protection circuit	Thermostat, Leak sensor						
Purge port	IN/OUT, M5 screw						
Ambient temp./humidity Ambient air quality	10 to 35°C, 35 to 80%RH (no condensation) Appropriate environment with no corrosive gas, solvents such as thinner, dust or combustible gas.						
Dimensions(Note 12)	W130×D263×H170 mm		W150×D294×H222 mm		W150×D294×H222 mm		W150×D294×H222 mm
Enclosure material	Poly vinyl chloride color: Ivory Approx. 8kg		Poly vinyl chloride color: Ivory Approx. 14kg		Poly vinyl chloride color: Ivory Approx. 15kg		Poly vinyl chloride color: Ivory Approx. 15kg
Connected Temperature Controller	HED003-C2A HED003-C2B		HED005-C2A HED005-C2B		HED007-C2A HED007-C2B		HED009-C2A HED009-C2B

Note 5) Determined under the following conditions;
 - Ambient temp. 25°C
 - Recirculating fluid: Water (flow rate 15 L/min, set temp. 25°C)
 - Facility water: temp. 25°C, flow rate 5L/min

Note 6) For the fluid applicable to the recirculating fluid, refer to Chapter 17 "Applicable Fluids". The compatibility of fluid other than described needs to be asked separately. Also, the product is not designed to be explosion proof, and not available for flammable fluid.

Note 7) The pump should be prepared by customers.

Note 8) Be sure to avoid the operation with the circulating pump stopped or with extremely small flow rate of recirculating fluid (7L/min or less for water). Otherwise, the product will repeat cooling and heating operation, which may shorten the life of the peltier device significantly, as well as it will become unable to control the temperature accurately.

Note 9) The Heat Exchanger should be installed at the discharge side of the circulating pump to avoid negative pressure applying.

Note 10) Only when used at recirculating fluid temperature below 50 °C

Note 11) If facility water is poured excluding the range of the specification, the noise and the vibration are generated. Moreover, facility water might become a high temperature.

Note 12) The dimensions do not include protruding part such as foot flange and tube.

■ **Pollution Degree**

This is the air pollution of the product used. This product is suitable for environments with a pollution degree of 1 or 2.

Pollution Degree 1	There is no pollution or only dry and nonconductive pollution occurs. An example of an environment of this degree is a clean room or a place using an air cleaner.
Pollution Degree 2	Normally, only nonconductive pollution occurs. The pollution may become conductive temporarily because of dew condensation. An example of an environment of this degree is a place where electric equipment can operate normally, such as a working office or a control panel.
Pollution Degree 3	Conductive pollution or dry and nonconductive pollution which can become conductive when dew condensation occurs. An example of an environment of this degree is a factory.
Pollution Degree 4	Conductive pollution that holds its conductivity due to conductive dust, rain or snow. An example of an environment of this degree is the outdoors.

9.3 Outline Dimensions

Detailed dimensions can be found in the specification drawing.

9.3.1 HED003-C2* Temperature Controller

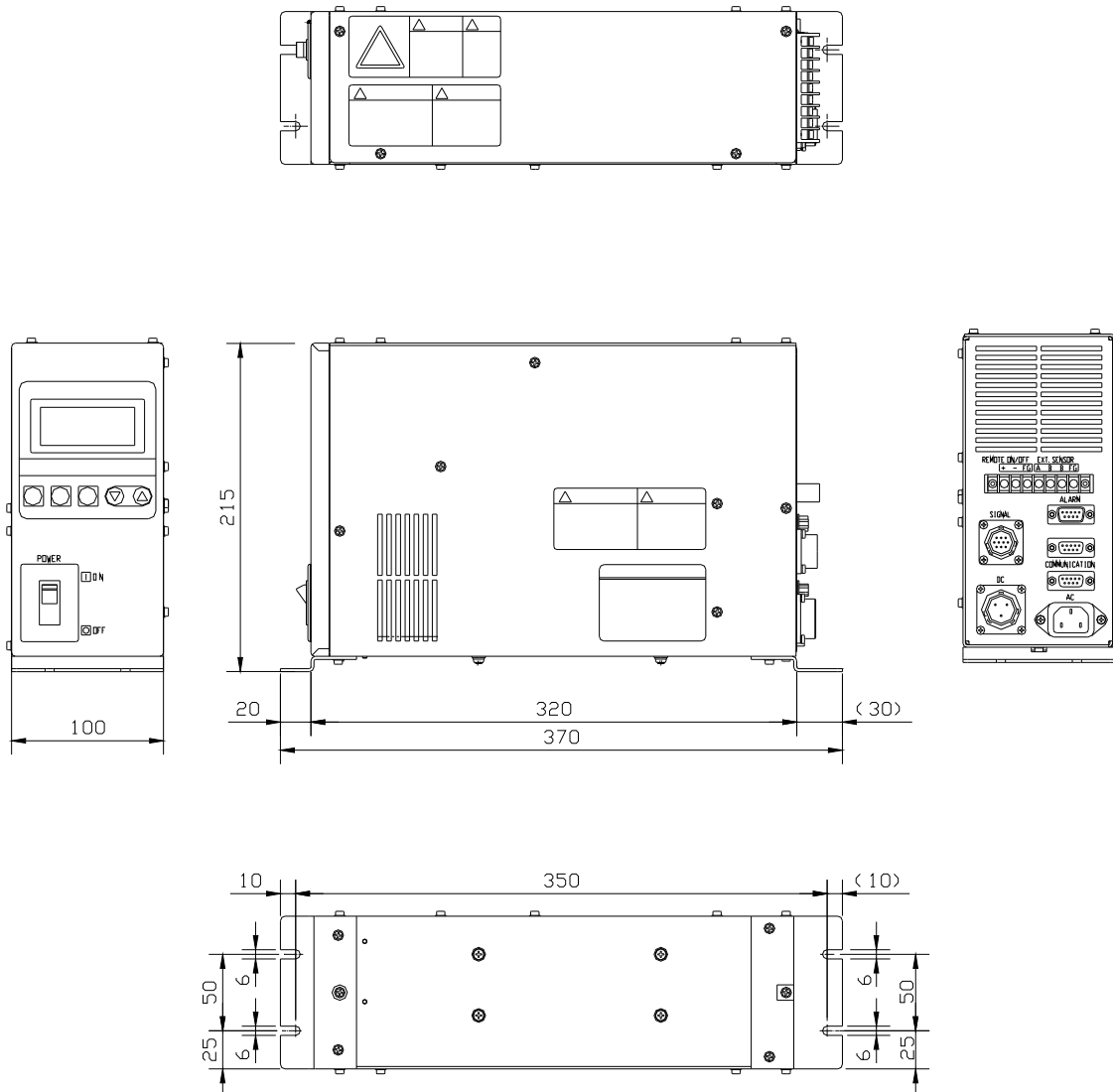

Fig. 9-1 Temperature Controller

9.3.2 HED003-HW* Heat Exchanger

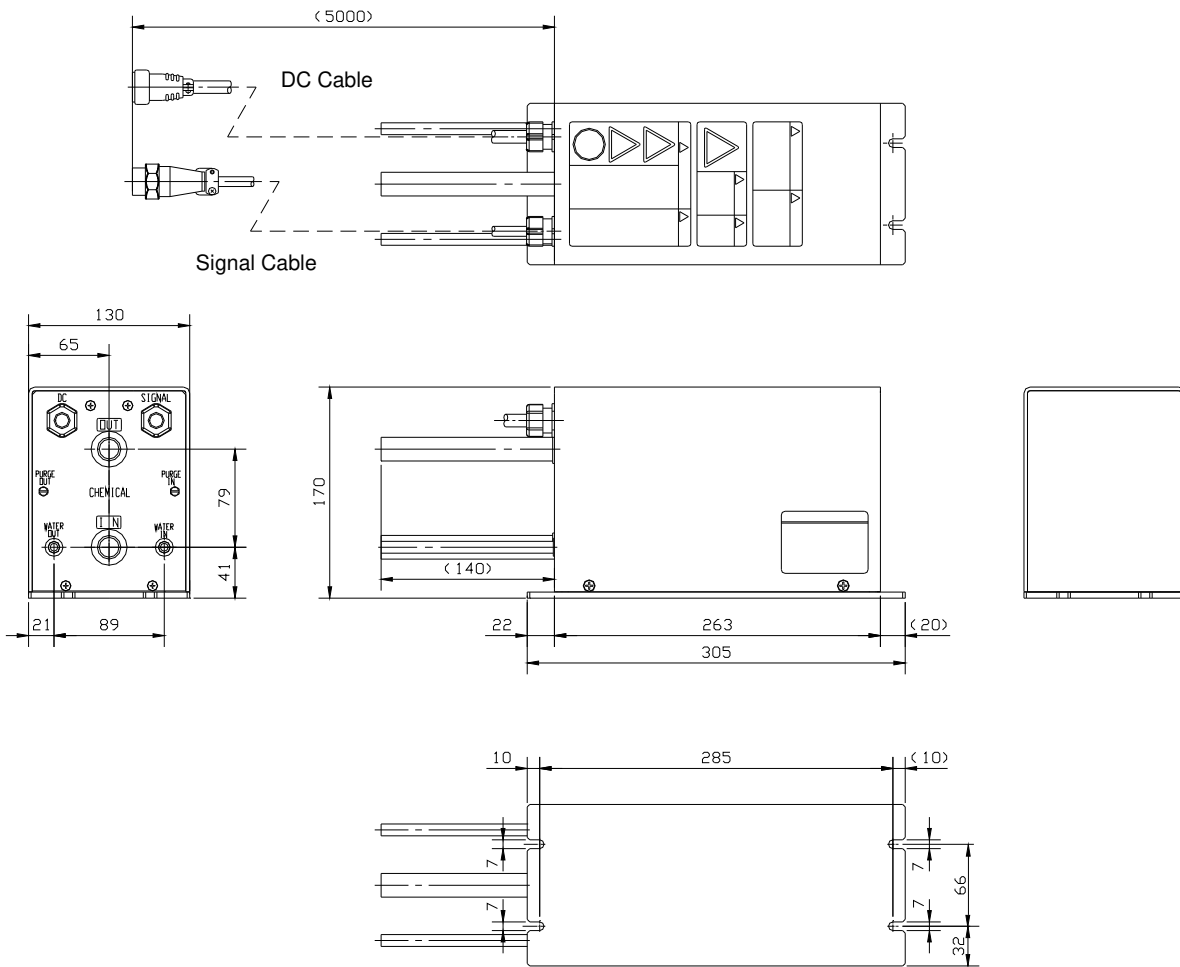

Fig. 9-2 Heat Exchanger

9.3.3 HED005-C2* Temperature Controller

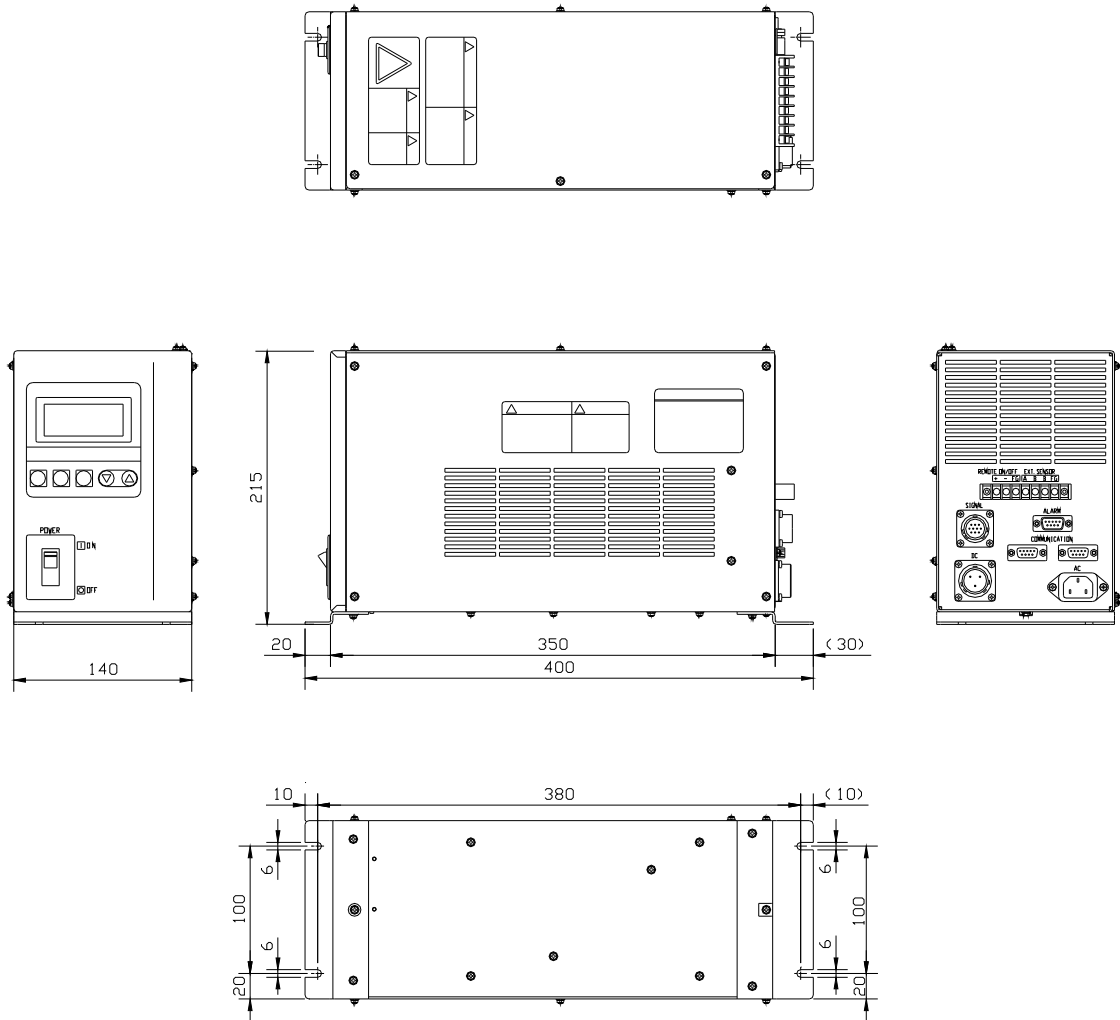

Fig. 9-3 Temperature Controller

9.3.4 HED005-HW* Heat Exchanger

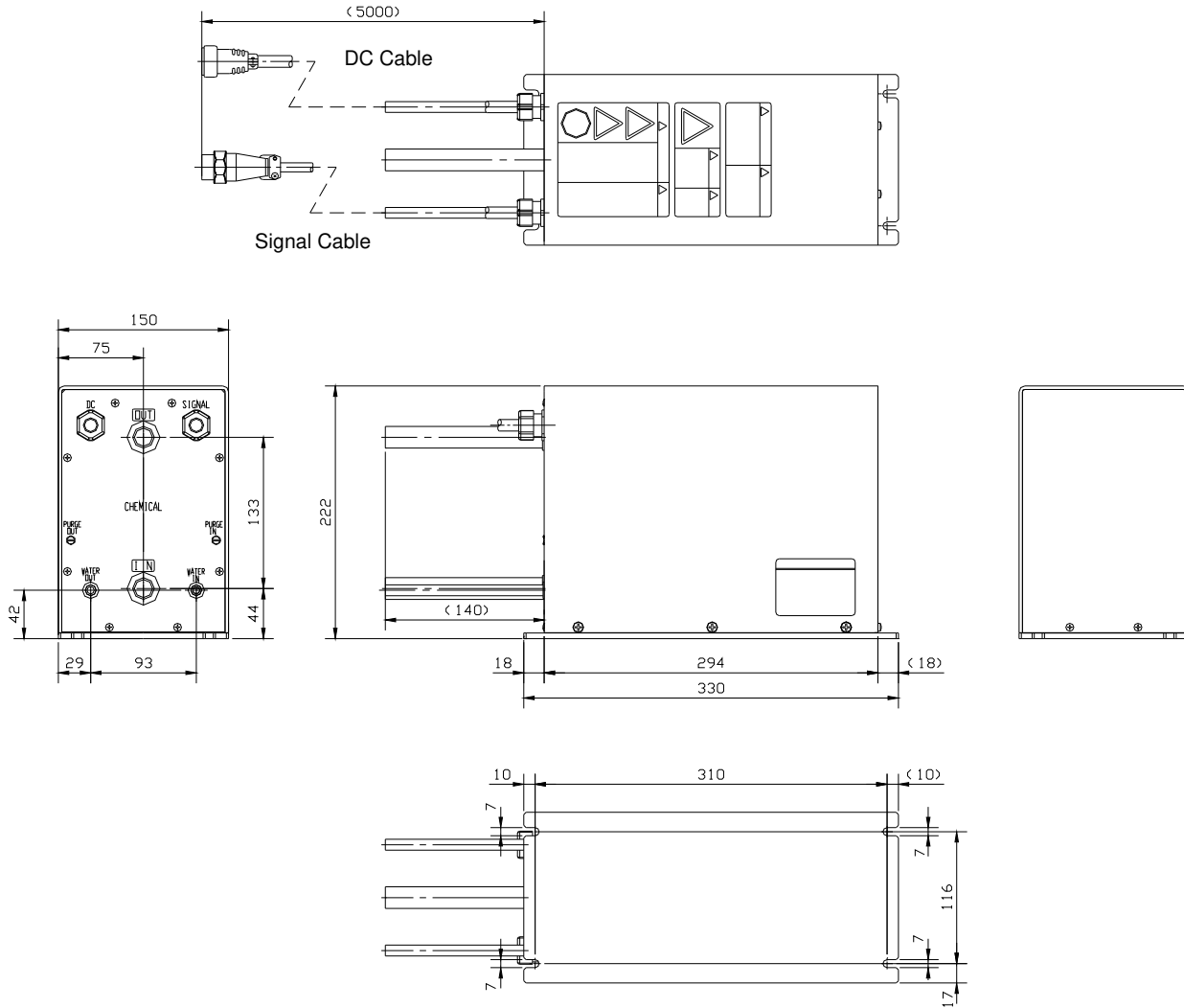

Fig. 9-4 Heat Exchanger

9.3.5 HED007-C2* Temperature Controller

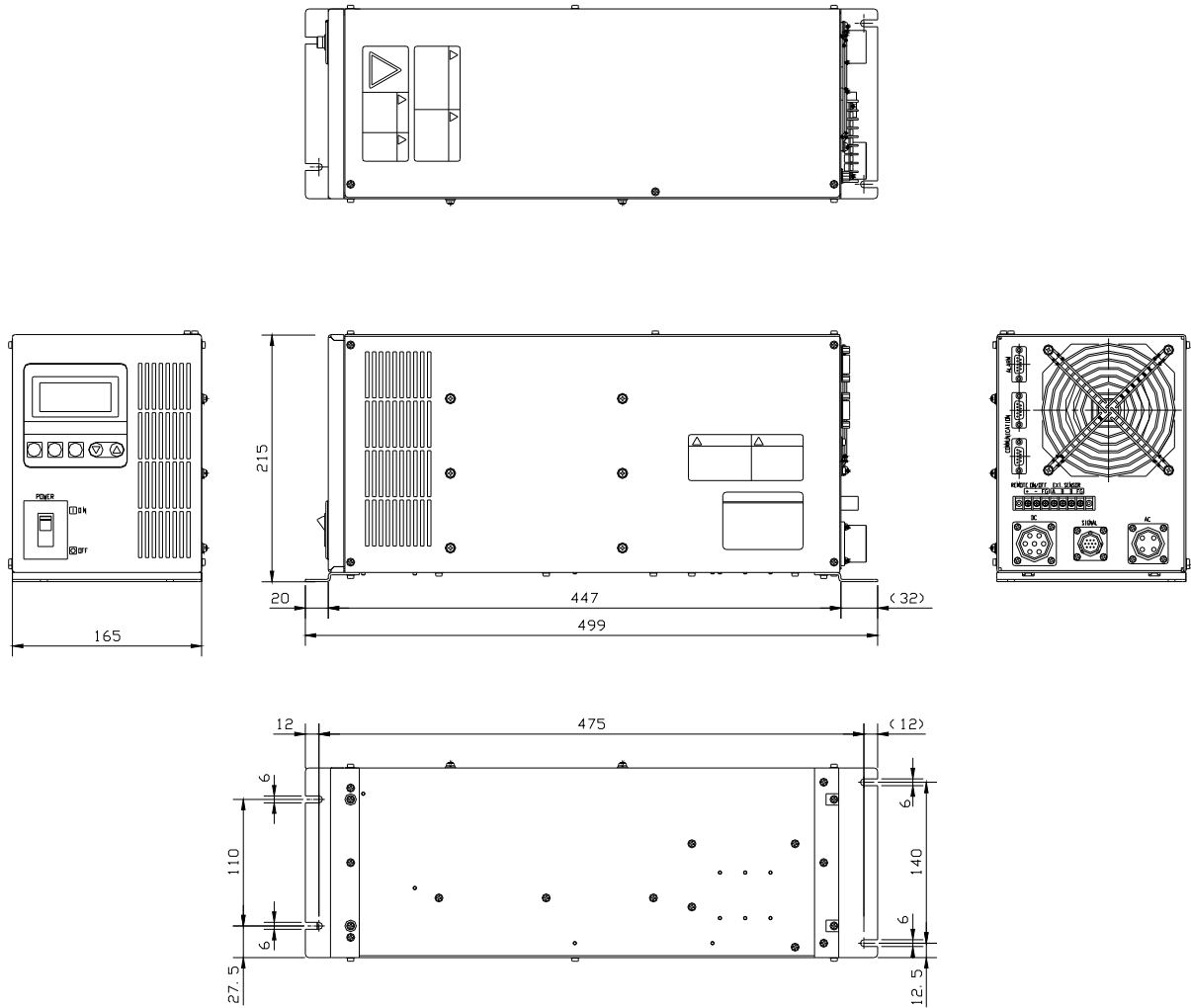

Fig. 9-5 Temperature Controller

9.3.6 HED007-HW* Heat Exchanger

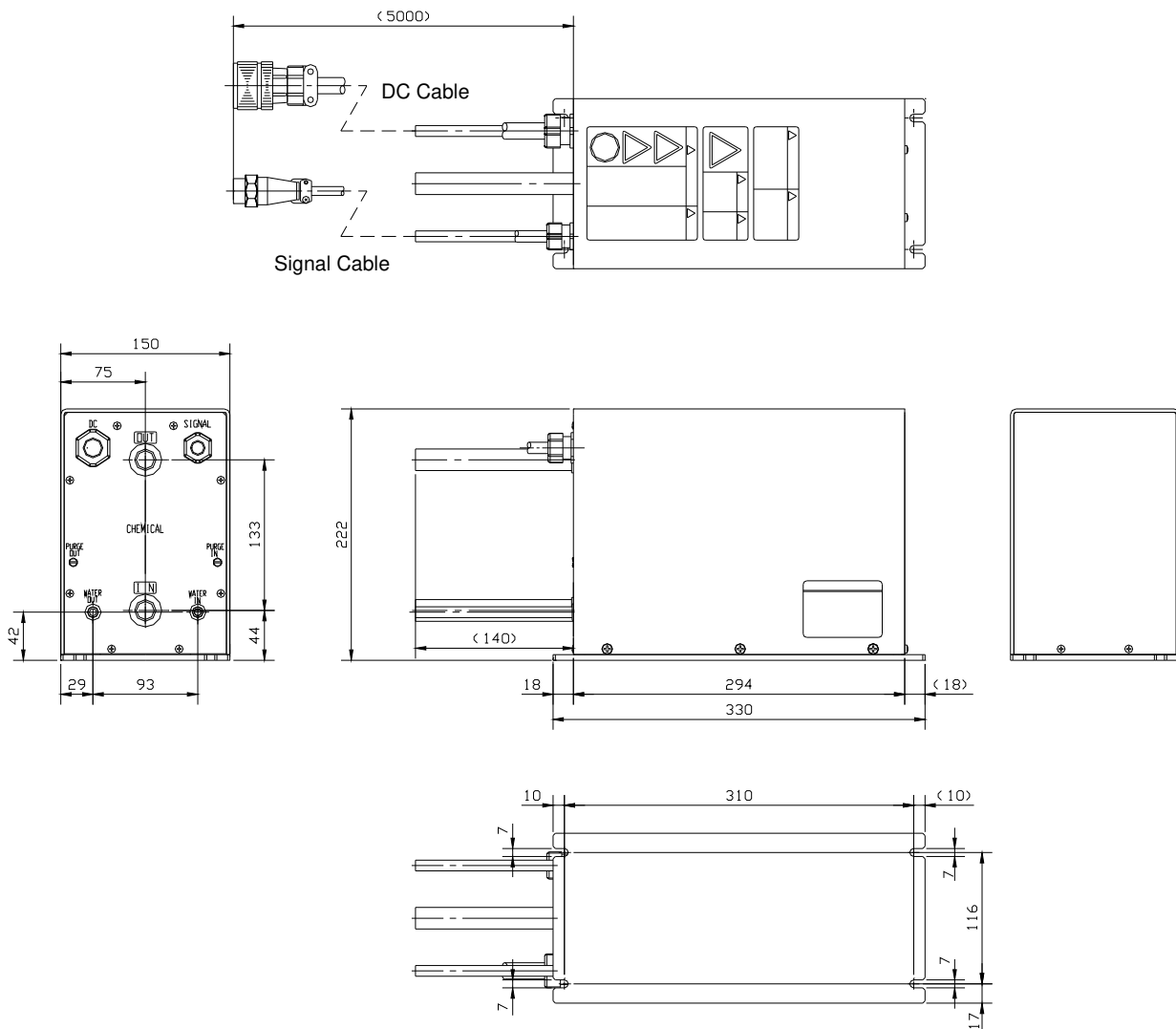

Fig. 9-6 Heat Exchanger

9.3.7 HED009-C2* Temperature Controller

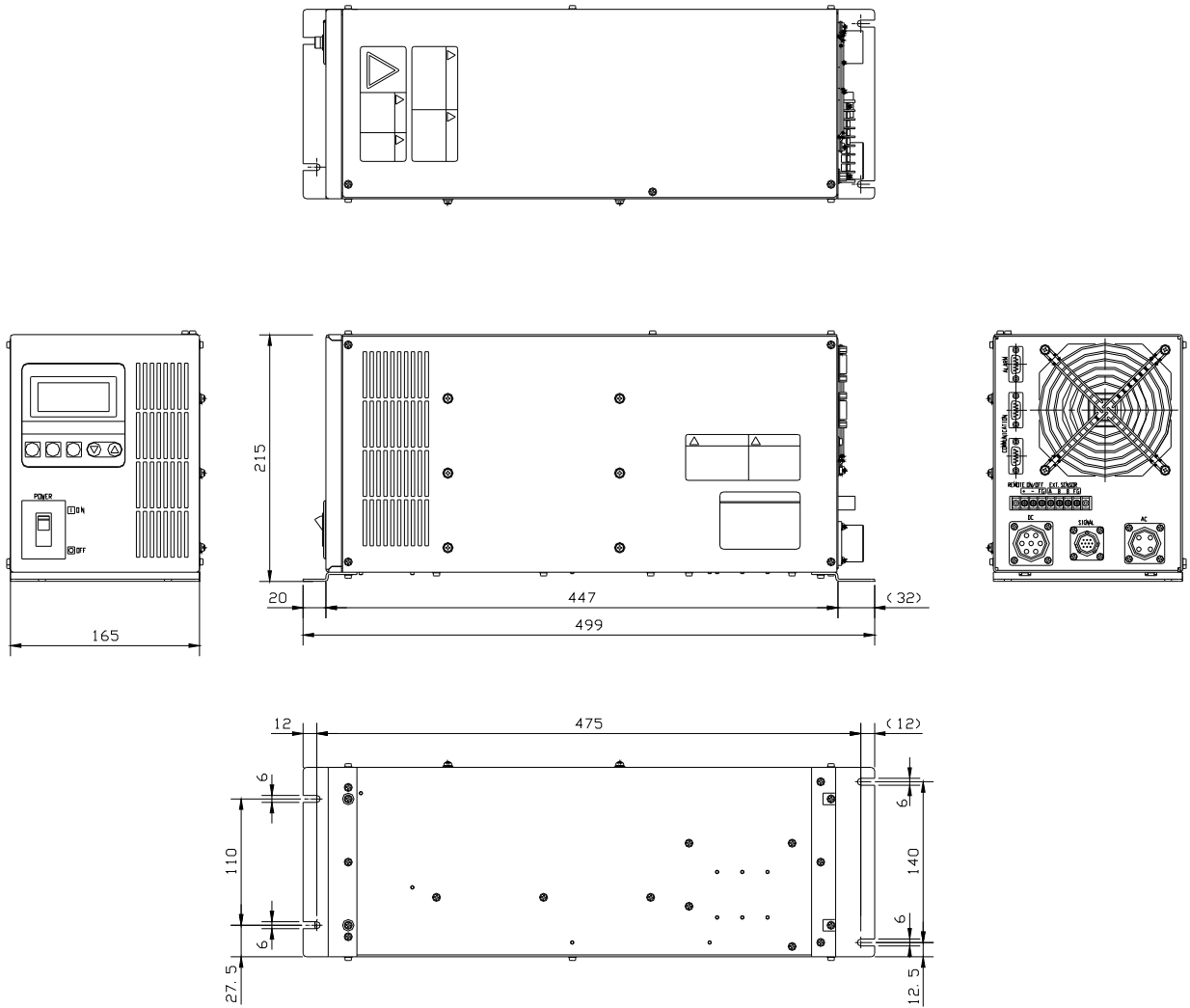

Fig. 9-7 Temperature Controller

9.3.8 HED009-HW* Heat Exchanger

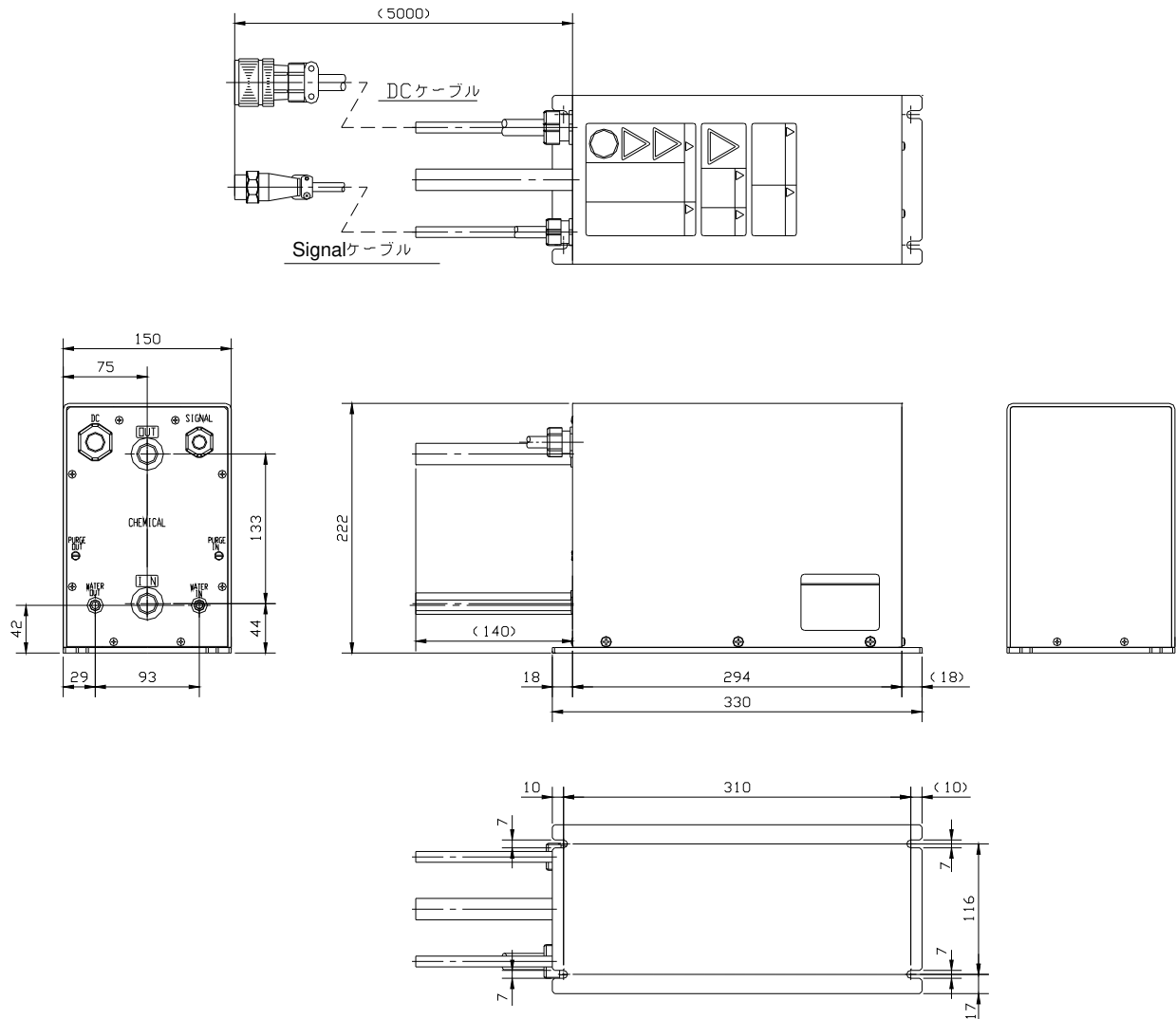

Fig. 9-8 Heat Exchanger

9.4 Specifications of Connectors

Use the specific power supply cable attached to the Temperature Controller.

Connect the DC cable and signal cable which runs from the Heat Exchanger to the DC connector and signal connector of the Temperature Controller respectively.

The connector and wiring with other connectors must be prepared separately by the customer.

9.4.1 Connector

1) Power supply connector (AC)

- HED003-C2*, HED005-C2*

Equivalent to IEC60320 C14

Connect attached specific power supply cable.

Pin No.	Signal
1	AC180-242V
2	AC180-242V
3	PE

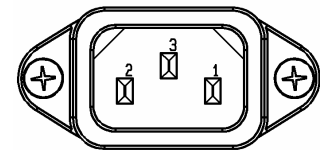

AC connector
(HED003-C2*, HED005-C2*)

- HED007-C2*.HED009-C2*

DDK: CE05-2A18-10PD-D

Connect attached specific power supply cable.

Pin No.	Signal
A	AC180-242V
B	AC180-242V
C	Unused
D	PE

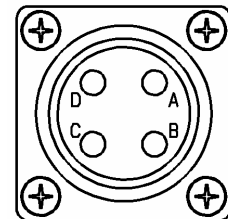

AC connector
(HED007-C2*, HED009-C2*)

2) DC connector

- HED003-C2*, HED005-C2*

Nanaboshi: NJC-243-RF (UL/CSA)

Connect the DC cable connector of Heat Exchanger.

Pin No.	Signal
1	DC output
2	DC output
3	FG

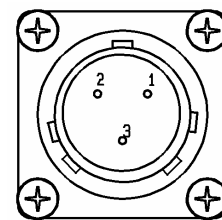

DC connector
(HED003-C2*, HED005-C2*)

- HED007-C2*,HED009-C2*

DDK D/MS3102A20-15S

Connect the DC cable connector of Heat Exchanger.

Pin No.	Signal
A	DC output
B	DC output
C	DC output
D	DC output
E	DC output
F	DC output
G	FG

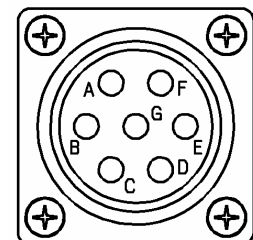

DC connector
(HED007-C2*,HED009-C2*)

3) Signal connector

- HED003-C2*, HED005-C2*, HED007-C2*, HED009-C2*
 DDK: JMR1610FG-36
 Connect the signal cable connector of Heat Exchanger.

Pin No.	Signal
1	Thermostat +
2	Thermostat -
3	RTD sensor terminal A (internal temp. sensor)
4	RTD sensor terminal B (internal temp. sensor)
5	RTD sensor terminal B (internal temp. sensor)
6	Leak sensor +24V
7	Leak sensor signal input
8	Leak sensor 24VE
9-10	Unused
Earth	FG

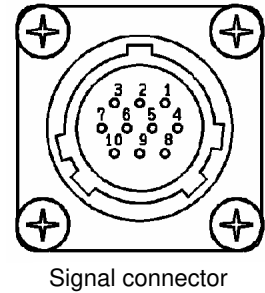

Signal connector

4) Terminal block

- HED003-C2*, HED005-C2*, HED007-C2*, HED009-C2*
 MORIMATSU: M111A-7A, Fixed screw M3
 Connection cable; 22AWG or more with a shield, Max. length 10m

Pin No.	Signal
1	Remote ON/OFF +
2	Remote ON/OFF -
3	FG (for shield)
4	External temperature sensor; RTD sensor terminal A
5	External temperature sensor; RTD sensor terminal B
6	External temperature sensor; RTD sensor terminal B
7	FG (for shield)

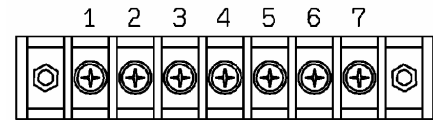

Terminal block

At the time of shipment from our factory, a short piece is installed between terminals no. 1 and 2 to make them short-circuited (Remote ON).

Remote ON/OFF signal:

Circuit voltage DC24V±10%, Passing current 2.9 to 4.3mA

External sensor signal:

Applicable sensor Pt100Ω, Passing current 2mA

5) Alarm output connector: D-sub 9 pins

- HED003-C2*, HED005-C2*, HED007-C2* HED009-C2*
 OMRON: Equivalent to XM2A-0901, fixed screw M2.6
 Connection cable; 22AWG or more with a shield, Max. length 10m

Pin No.	Signal
1	Output Cutoff Alarm a contact (OPEN during Alarm)
2	Output Cutoff Alarm common
3	Output Cutoff Alarm b contact (CLOSED during Alarm)
4	Temp. upper/lower limit Alarm a contact (OPEN during Alarm)
5	Temp. upper/lower limit Alarm common
6	Temp. upper/lower limit Alarm b contact (CLOSED during Alarm)
7 - 9	Unused

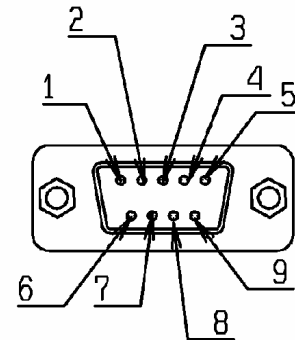

Communication connector
 D-sub 9 pins (pin type)

Contact rating: 0.3A at 125VAC, 2A at 30VDC (at resistive load)

6) Communication connector: D-sub 9 pins

OMRON: Equivalent to XM2D-0901, fixed screw M2.6
Connection cable; 22AWG or more with a shield

- 1) HED003-C2A, HED005-C2A, HED007-C2A, HED009-C2A

RS-485

Pin No.	Signal
1	RS-485 BUS+
2	RS-485 BUS-
3	Unused
4	Unused
5	SG
6 - 9	Unused

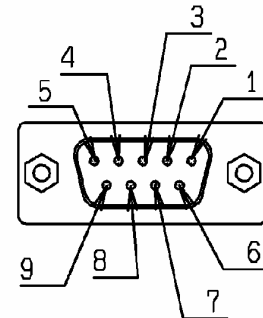

- 2) HED003-C2B, HED005-C2B, HED007-C2B, HED009-C2B

RS-232C

Pin No.	Signal
1	Unused
2	RS-232C RD
3	RS-232C SD
4	Unused
5	SG
6 - 9	Unused

Communication connector
D-sub 9 pins (socket type)

9.4.2 Power supply cable

⚠ 注意



- The power supply cable is specific to the Chemical Thermo-con. Do not use this cable for other purposes, and never use other cables for this product.

1) Power supply cable (Accessory)

- HED003-C2*, HED005-C2*

Cable: 14AWG, Length 2m

Connector: Equivalent to IEC60320 C13

Connect the power supply connector of Temperature Controller.

Line No.	Signal
Black 1	AC180-242V
Black 2	AC180-242V
Green/Yellow	PE

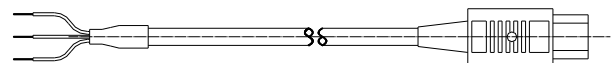

Power supply cable
(HED003-C2*, HED005-C2*)

- HED007-C2*, HED009-C2*

Cable: 12AWG Length 2m

Connector: DDK CE05-6A18-10SD-D

Connect the power supply connector of Temperature Controller.

Line No.	Signal
Black 1	AC180-242V
Black 2	AC180-242V
Green/Yellow	PE

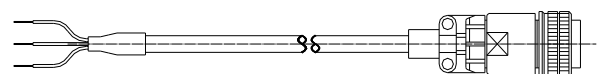

Power supply cable
(HED007-C2*, HED009-C2*)

9.5 Performance Chart

The values on the performance chart are not guaranteed values.
 Take safety margins into consideration in the customer's machine.

9.5.1 Performance of HED003

Conditions; Recirculating fluid: water (flow rate 15L/min),
 Facility water flow rate: 5L/min, Ambient temp.: 25°C

1) Cooling capacity

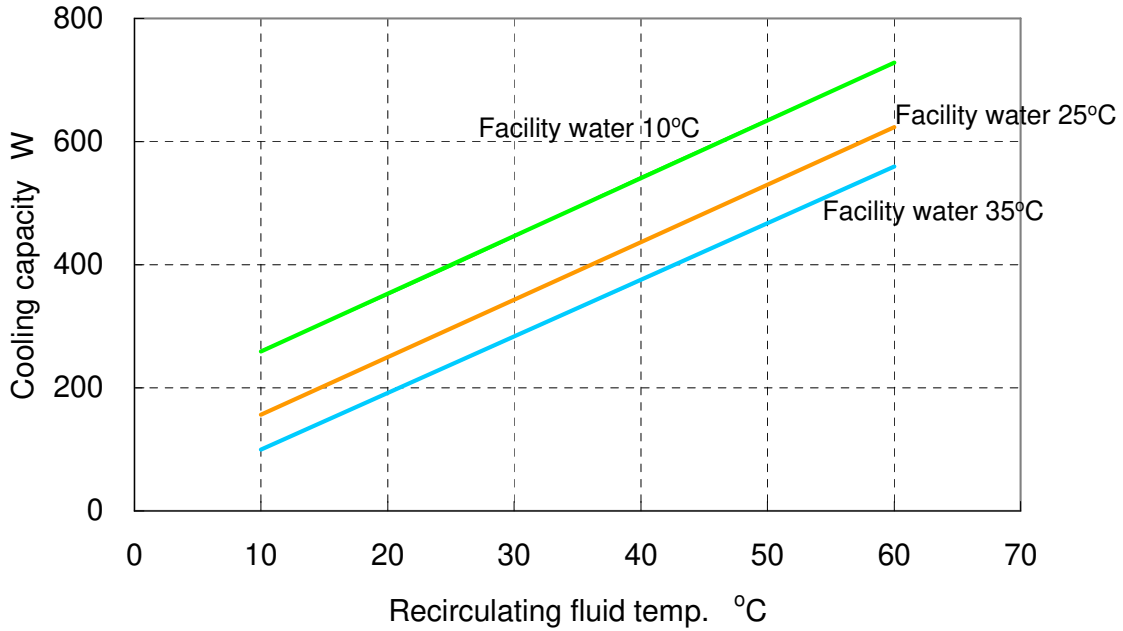

Fig. 9-7 Cooling capacity (HED003)

2) Heating capacity

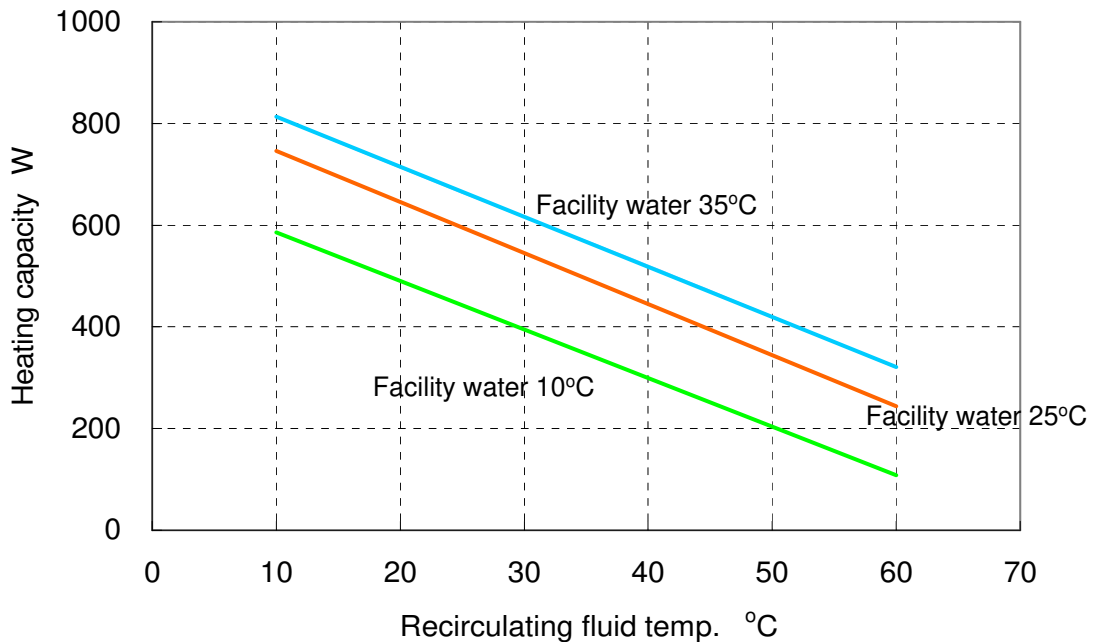

Fig.9-8 Heating capacity (HED003)

9.5.2 Performance of HED005

Conditions; Recirculating fluid: water (flow rate 15L/min),
 Facility water flow rate: 5L/min, Ambient temp.: 25°C

1) Cooling capacity

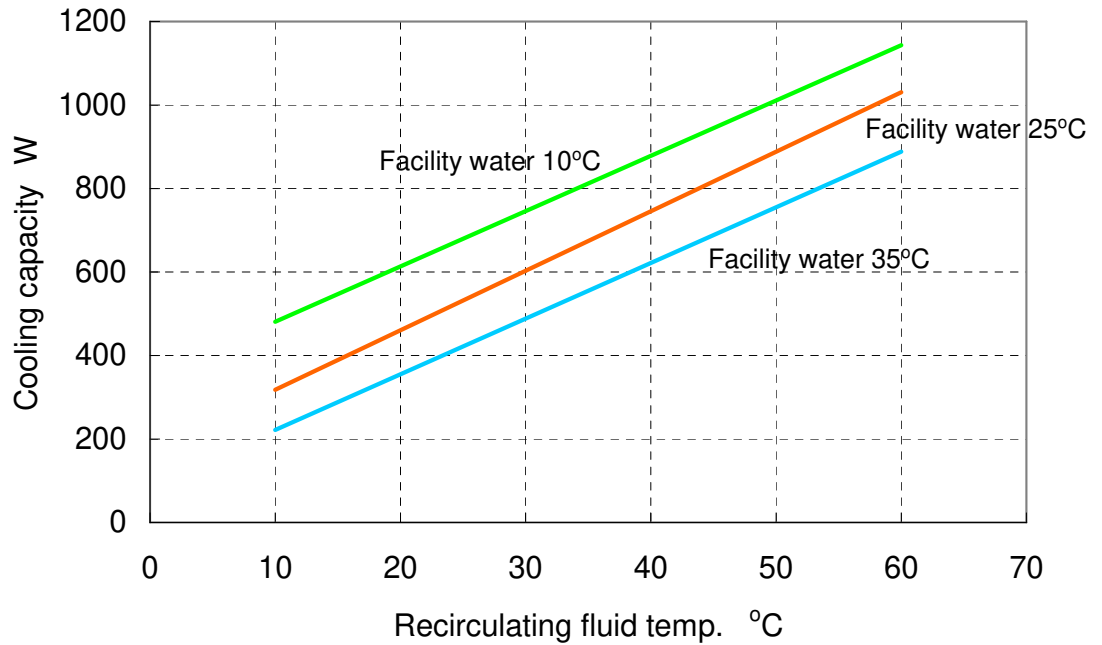

Fig.9-9 Cooling capacity (HED005)

2) Heating capacity

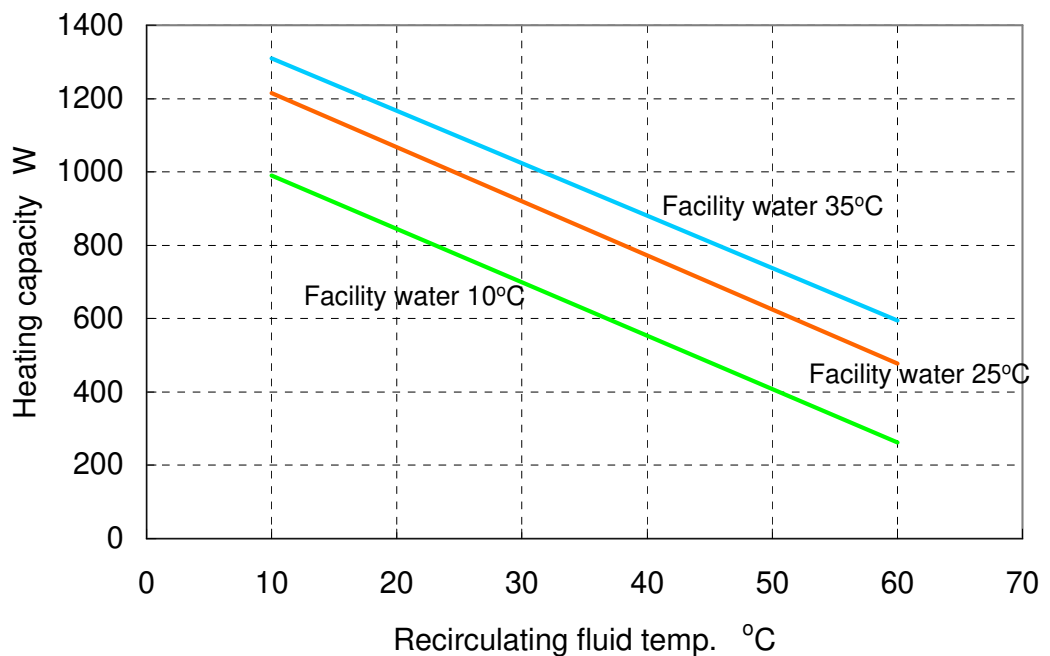

Fig.9-10 Heating capacity (HED005)

9.5.3 Performance of HED007

Conditions; Recirculating fluid: water (flow rate 15L/min),
 Facility water flow rate: 5L/min, Ambient temp.: 25°C

1) Cooling capacity

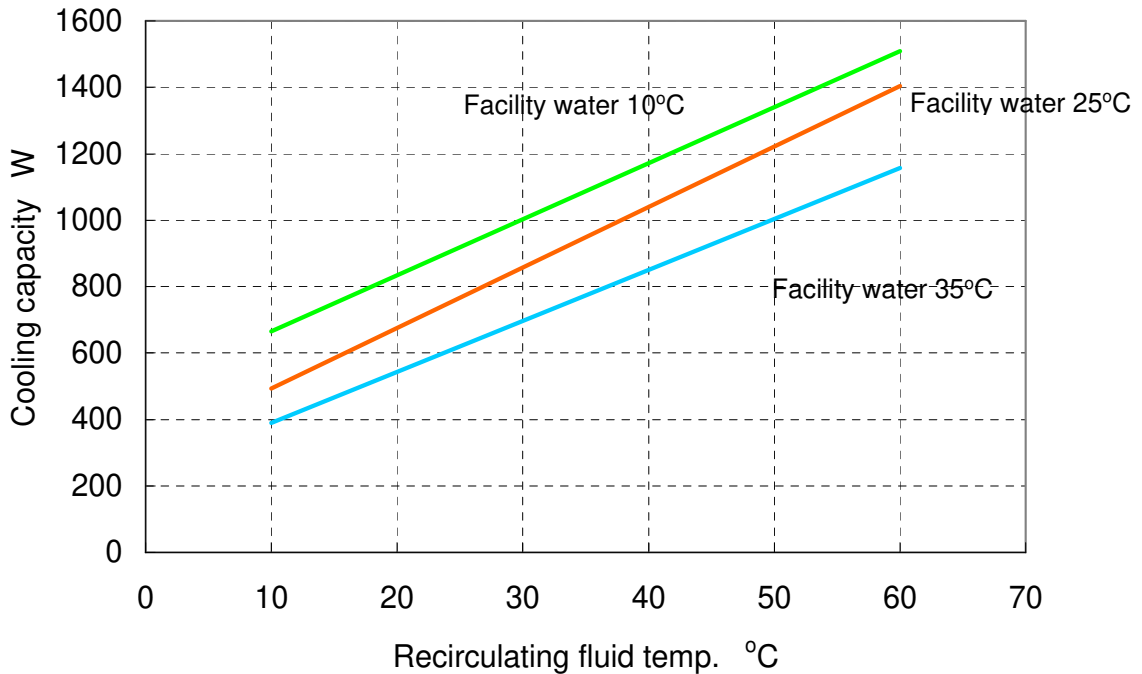

Fig.9-11 Cooling capacity (HED007)

2) Heating capacity

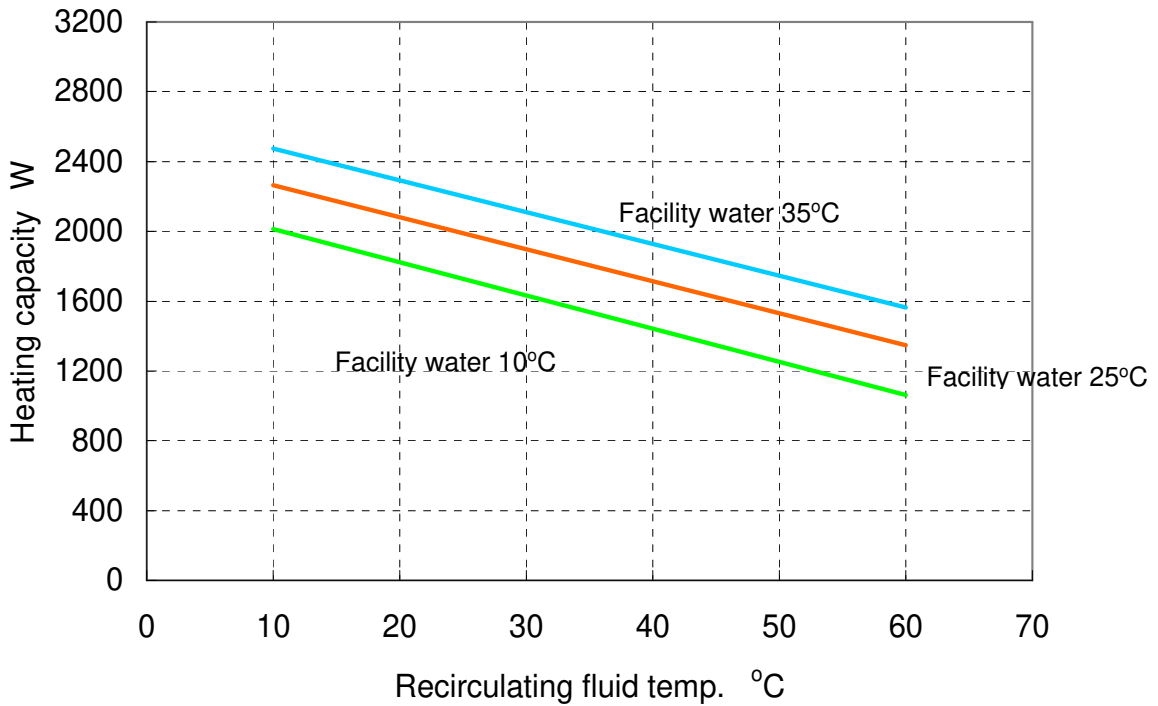

Fig.9-12 Heating capacity (HED007)

9.5.4 Performance of HED009

Conditions; Recirculating fluid: water (flow rate 15L/min),
Facility water flow rate: 5L/min, Ambient temp.: 25°C

1) Cooling capacity

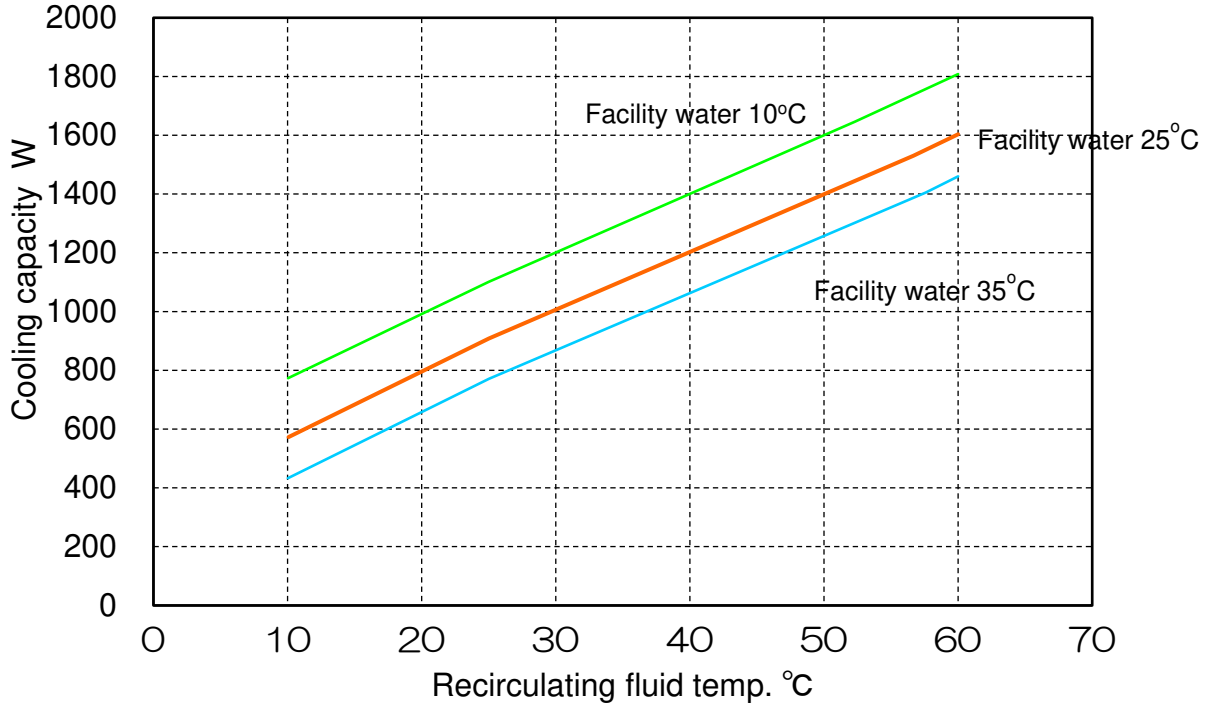

Fig.9-13 Cooling capacity (HED009)

2) Heating capacity

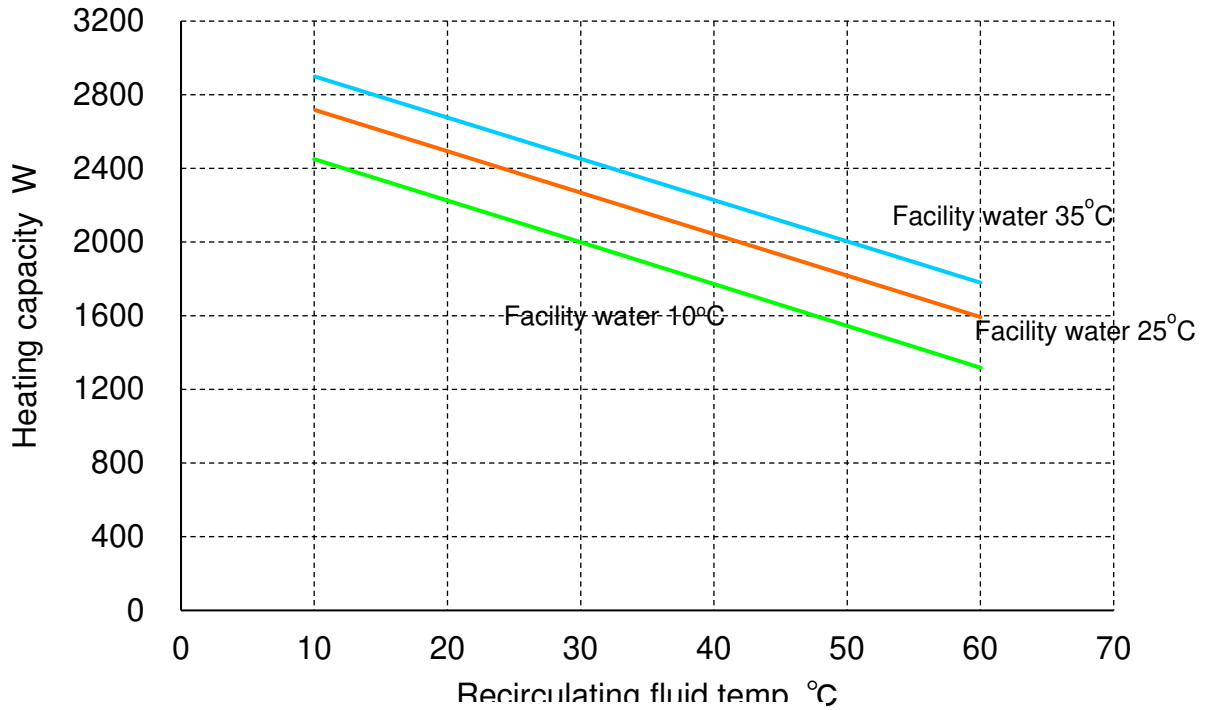

Fig.9-14 Heating capacity (HED009)

9.5.5 Recirculating fluid Pressure Loss

Fluid: Water

■ HED003

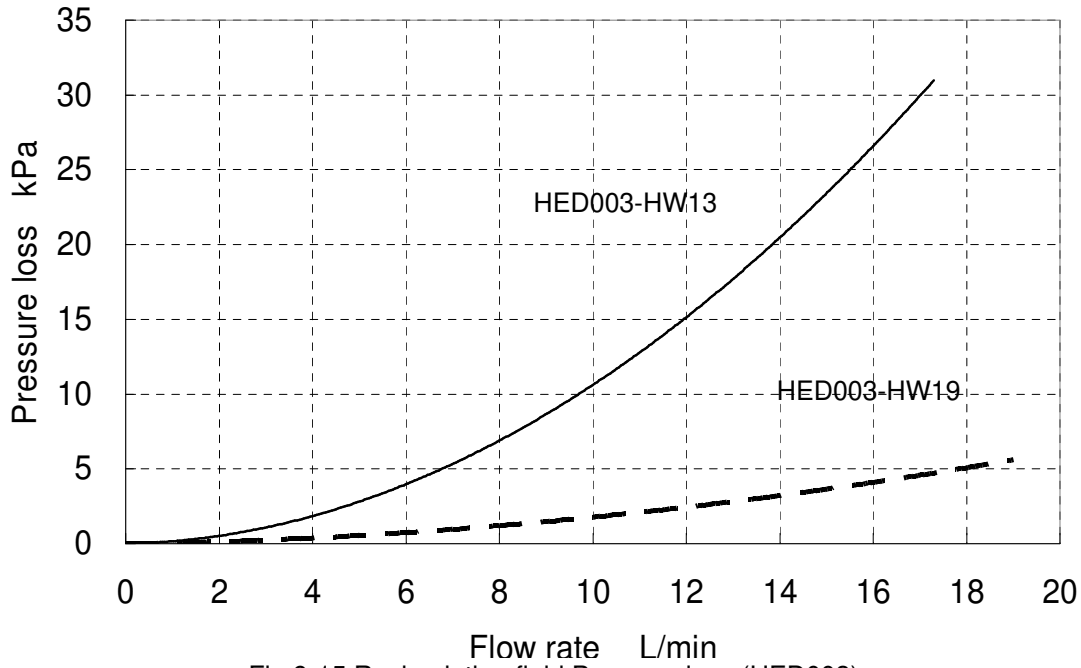

Fig.9-15 Recirculating fluid Pressure loss (HED003)

■ HED005, HED007

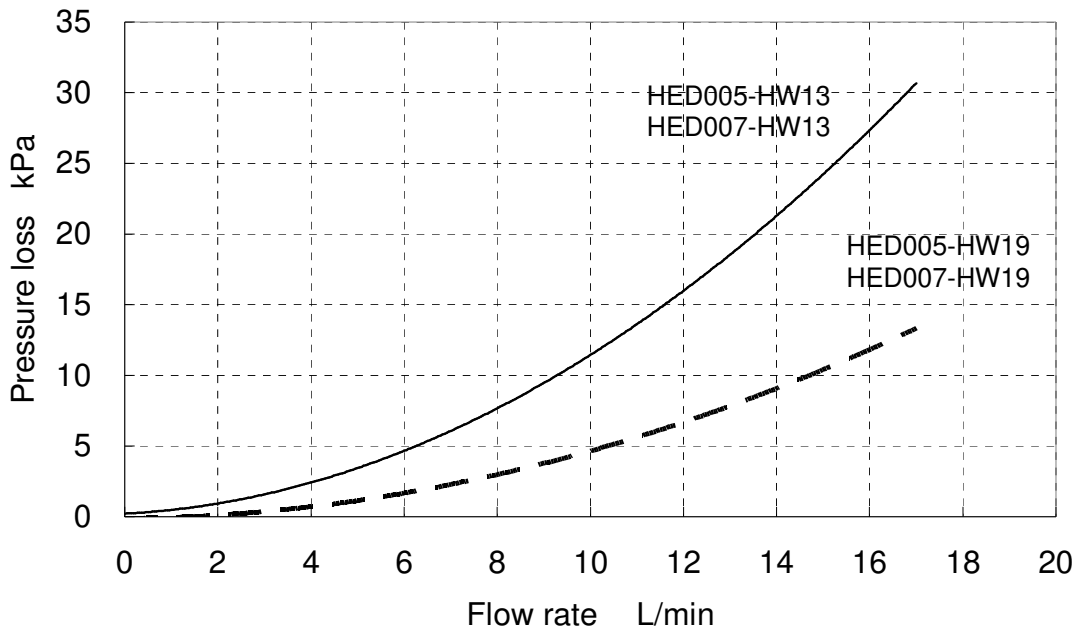

Fig.9-16 Recirculating fluid Pressure loss (HED005/007)

■ HED009

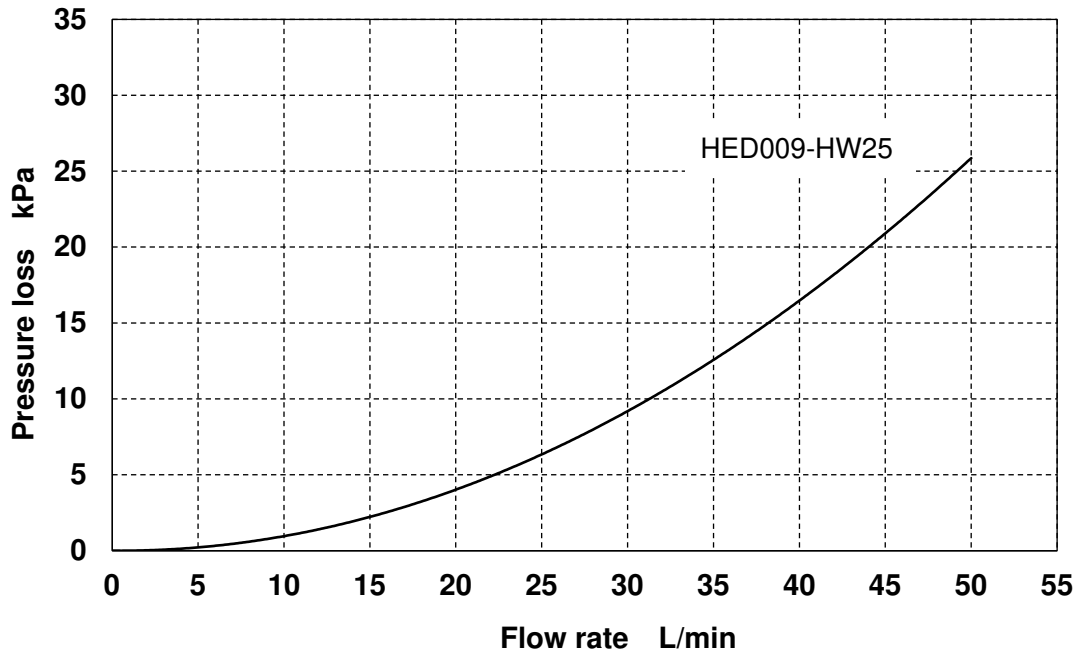

Fig.9-17 Recirculating fluid Pressure loss (HED009)

9.5.6 Facility water Pressure Loss

Fluid: Water

■ HED003

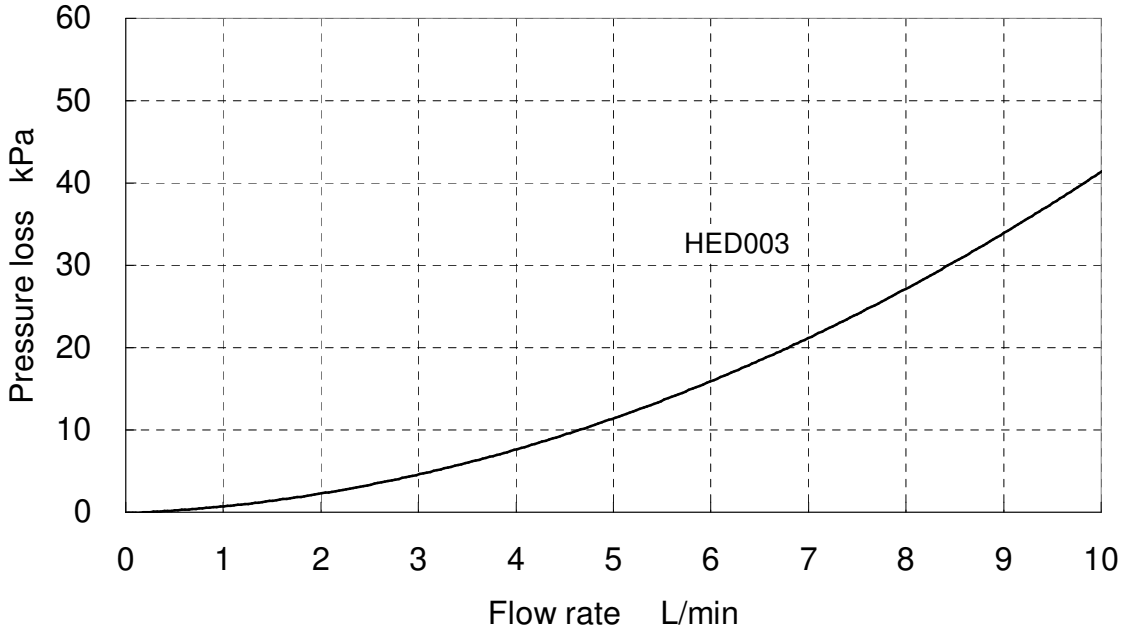

Fig.9-18 Facility water Pressure Loss (HED003)

■ HED005, HED007, HED009

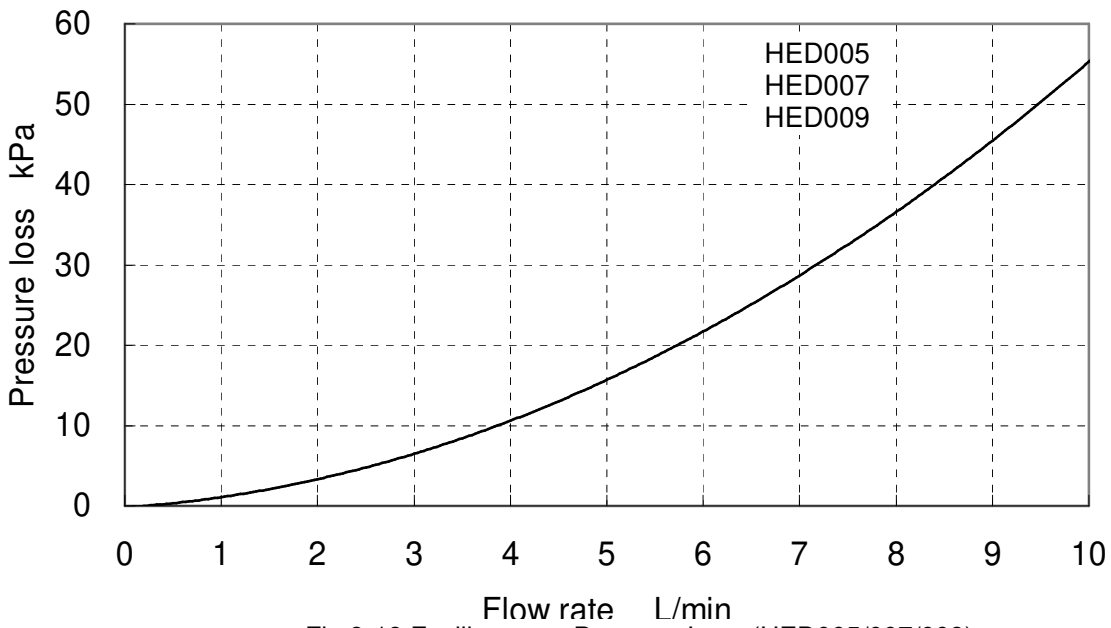

Fig.9-19 Facility water Pressure Loss (HED005/007/009)

9.6 Applicable Fluids

Check list for compatibility of fluids with the product materials

Chemicals	Concentration		Operating temperature range	Suitability	
	Standard	Option -Y		Standard	Option -Y
Hydrofluoric acid	HF : 10% or less	HF : 49% or less	10 to 40°C	○ ^{Note 2)}	○ ^{Note 2)}
Buffered hydrogen fluoride	HF : 10% or less	HF : 49% or less	10 to 40°C	○ ^{Note 2)}	○ ^{Note 2)}
Hydrofluoric acid and Nitric acid mixture	HF : 5% or less HNO ₃ : 5% or less	HF : 49% or less HNO ₃ : 70% or less	/	△	○
Nitric acid	HNO ₃ : 5% or less	HNO ₃ : 70% or less	/	△	○
Hydrochloric acid	HCl : 5% or less	HCl : 35% or less	/	△	○
Copper sulfate solution	H ₂ SO ₄ : 96% or less		10 to 50°C note) HED007,HED009:10 to 30°C	○ ^{Note 2)}	○ ^{Note 2)}
Sulfuric acid (excluding fuming sulfuric acid)	H ₂ SO ₄ : 96% or less		10 to 50°C note) HED007,HED009:10 to 30°C	○ ^{Note 2)}	○ ^{Note 2)}
Ozone water	—		10 to 60°C	○ ^{Note 3)}	△
Ammonium hydroxide	NH ₃ : 5% or less		10 to 60°C	○ ^{Note 2)}	○ ^{Note 2)}
Ammonia hydrogen peroxide solution	NH ₃ : 5% or less H ₂ O ₂ : 20% or less		10 to 60°C	○ ^{Note 1,2)}	○ ^{Note 1,2)}
Sodium hydroxide	NaOH : 50% or less		10 to 60°C	○ ^{Note 2)}	○ ^{Note 2)}
DI water	—		10 to 60°C	○ ^{Note 1)}	△
Ultra-pure water	—		10 to 60°C	○ ^{Note 1,3)}	△

Key ○ : Suitable
△ : Use at Customer own discretion

- * The check list for the compatibility between the material and fluid is for reference, and cannot guarantee the suitability of the fluid.
- * SMC takes no responsibility for the accuracy of the check list or any damage incurred by the reference to the check list.
- * The product is not designed to be explosion proof, and is not suitable for flammable fluids.

Note 1) The product can generate static electricity, and measures must be taken against it.
Static electricity is generated by dynamic friction of fluid and can discharge to parts such as the temperature sensor, which can cause the product to malfunction.
An example of the measures against static electricity is to ground the discharge by using a PFA conductive tube or metal piping (metal flexible hose).

Note 2) The fluid can permeate, and affect the product life. If the fluid also generates corrosive gas, perform N₂ supply and exhaust (N₂ purge) inside the Heat Exchanger.

Note 3) Do not suggest to using by HED009 Series.

9.7 Calculation of Dew Point Temperature (from psychrometric chart)

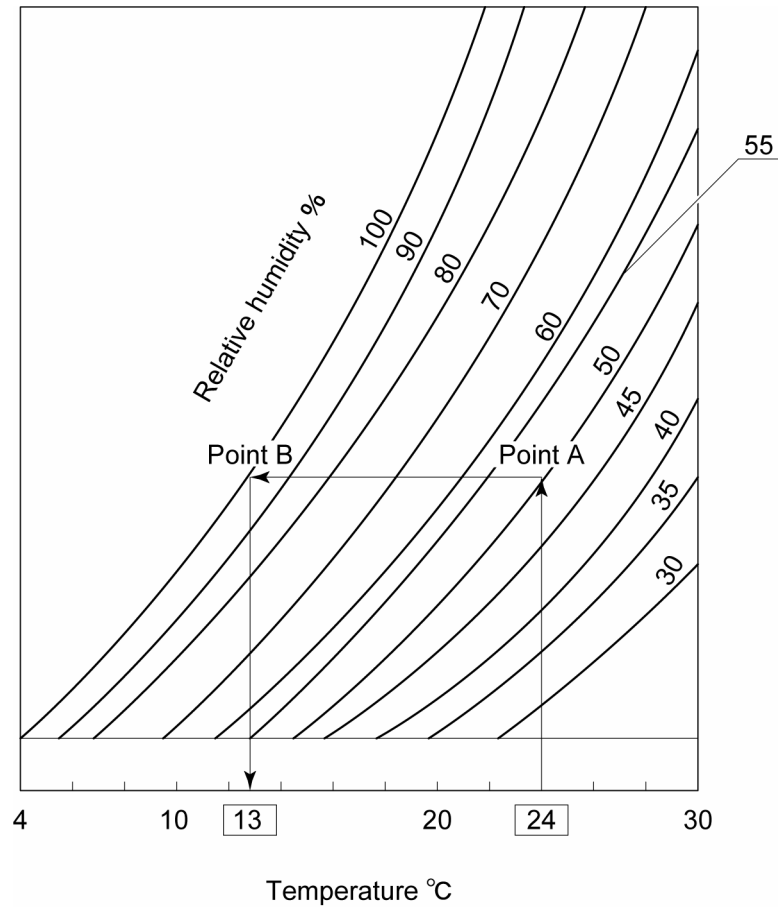

Fig.9-13 Psychrometric chart

1. Measure the ambient temperature and humidity.
2. Plot the ambient temperature on the X axis, "Temp." (ex. 24°C), and draw a vertical line from there.
3. Find the intersection (A) between the curve with the value closest to the ambient humidity and the straight vertical line.
4. Draw a line parallel to the X axis from intersection A and find the intersection (B) between this line and the curve representing 100% relative humidity.
5. Draw a vertical line to the X axis from intersection B. The temperature at the intersection between this line and the X axis is the dew point (in this example, 13°C). If the temperature falls to this value, the moisture contained in the air will begin to form condensation.

9.8 Conforming Standards/Laws

9.8.1 Safety Standards

The product complies with the following standards.

- CE Marking: EMC Directive
Low Voltage Directive
- SEMI: S2, F47 (Excluding HED009 series)

9.8.2 Cautions for Export

When the product is exported, strictly follow the laws required by the Ministry of Economy, Trade and Industry (Foreign Exchange and Foreign Trade Control Law).

Revision history
Revision2: March.2024

SMC Corporation

URL <https://www.smcworld.com>

Note: Specifications are subject to change without prior notice and any obligation on the part of the manufacturer.
© 2024 SMC Corporation All Rights Reserved