



Operation Manual

PRODUCT NAME

SMC Wireless System
EtherNet/IP® compatible

MODEL / Series / Product Number

EX600-WEN# (Base)
EX600-WSV# (Remote)

SMC Corporation

Contents

Safety Instructions	2
SMC Wireless System Features	11
SMC Wireless System Outline	12
Outline	12
System configuration	13
Base	14
Remote	15
Definition and terminology	16
Assembly	18
Mounting and Installation	21
Installation	21
Model Indication and How to Order	24
Summary of Product Parts	25
Connector (Base only)	26
LED Display	27
LED indication of base	27
LED indication of remote	29
Setting and Adjustment	30
Setting	31
Dimensions	47
I/O Map	49
I/O mapping	50
I/O mapping order of base/remote	51
Diagnostic allocation	57
Detailed diagnostic data	58
Specifications	65
Troubleshooting	71
End Plate	
Model Indication and How to Order	87
Summary of Product parts	88
Mounting and Installation	90
Wiring	90
Specifications	92
Dimensions	93
Accessories	103



Safety Instructions

These safety instructions are intended to prevent hazardous situations and/or equipment damage. These instructions indicate the level of potential hazard with the labels of “**Caution**,” “**Warning**” or “**Danger**.” They are all important notes for safety and must be followed in addition to International Standards (ISO/IEC)^{*)}, and other safety regulations.

*1) ISO 4414: Pneumatic fluid power - General rules and safety requirements for systems and their components
ISO 4413: Hydraulic fluid power - General rules and safety requirements for systems and their components
IEC 60204-1: Safety of machinery - Electrical equipment of machines - Part 1: General requirements
ISO 10218-1: Robots and robotic devices - Safety requirements for industrial robots - Part 1: Robots
etc.



Danger

Danger indicates a hazard with a high level of risk which, if not avoided, will result in death or serious injury.



Warning

Warning indicates a hazard with a medium level of risk which, if not avoided, could result in death or serious injury.



Caution

Caution indicates a hazard with a low level of risk which, if not avoided, could result in minor or moderate injury.

Warning

1. The compatibility of the product is the responsibility of the person who designs the equipment or decides its specifications.

Since the product specified here is used under various operating conditions, its compatibility with specific equipment must be decided by the person who designs the equipment or decides its specifications based on necessary analysis and test results. The expected performance and safety assurance of the equipment will be the responsibility of the person who has determined its compatibility with the product. This person should also continuously review all specifications of the product referring to its latest catalog information, with a view to giving due consideration to any possibility of equipment failure when configuring the equipment.

2. Only personnel with appropriate training should operate machinery and equipment.

The product specified here may become unsafe if handled incorrectly. The assembly, operation and maintenance of machines or equipment including our products must be performed by an operator who is appropriately trained and experienced.

3. Do not service or attempt to remove product and machinery/equipment until safety is confirmed.

1. The inspection and maintenance of machinery/equipment should only be performed after measures to prevent falling or runaway of the driven objects have been confirmed.
2. When the product is to be removed, confirm that the safety measures as mentioned above are implemented and the power from any appropriate source is cut, and read and understand the specific product precautions of all relevant products carefully.
3. Before machinery/equipment is restarted, take measures to prevent unexpected operation and malfunction.

4. Our products cannot be used beyond their specifications. Our products are not developed, designed, and manufactured to be used under the following conditions or environments. Use under such conditions or environments is not covered.

1. Conditions and environments outside of the given specifications, or use outdoors or in a place exposed to direct sunlight.
2. Use for nuclear power, railways, aviation, space equipment, ships, vehicles, military application, equipment affecting human life, body, and property, fuel equipment, entertainment equipment, emergency shut-off circuits, press clutches, brake circuits, safety equipment, etc., and use for applications that do not conform to standard specifications such as catalogs and operation manuals.
3. Use for interlock circuits, except for use with double interlock such as installing a mechanical protection function in case of failure. Please periodically inspect the product to confirm that the product is operating properly.



Safety Instructions

Caution

We develop, design, and manufacture our products to be used for automatic control equipment, and provide them for peaceful use in manufacturing industries. Use in non-manufacturing industries is not covered.

Products we manufacture and sell cannot be used for the purpose of transactions or certification specified in the Measurement Act.

The new Measurement Act prohibits use of any unit other than SI units in Japan.

Limited warranty and Disclaimer/Compliance Requirements

The product used is subject to the following “Limited warranty and Disclaimer” and “Compliance Requirements”.

Read and accept them before using the product.

Limited warranty and Disclaimer

1. The warranty period of the product is 1 year in service or 1.5 years after the product is delivered, whichever is first.*2)
Also, the product may have specified durability, running distance or replacement parts. Please consult your nearest sales branch.
2. For any failure or damage reported within the warranty period which is clearly our responsibility, a replacement product or necessary parts will be provided.
This limited warranty applies only to our product independently, and not to any other damage incurred due to the failure of the product.
3. Prior to using SMC products, please read and understand the warranty terms and disclaimers noted in the specified catalog for the particular products.

***2) Vacuum pads are excluded from this 1 year warranty.**

A vacuum pad is a consumable part, so it is warranted for a year after it is delivered.

Also, even within the warranty period, the wear of a product due to the use of the vacuum pad or failure due to the deterioration of rubber material are not covered by the limited warranty

Compliance Requirements

1. The use of SMC products with production equipment for the manufacture of weapons of mass destruction (WMD) or any other weapon is strictly prohibited.
2. The exports of SMC products or technology from one country to another are governed by the relevant security laws and regulations of the countries involved in the transaction. Prior to the shipment of a SMC product to another country, assure that all local rules governing that export are known and followed.

Operator

- ◆ This operation manual is intended for those who have knowledge of machinery using pneumatic equipment, and have sufficient knowledge of assembly, operation and maintenance of such equipment. Only those persons are allowed to perform assembly, operation and maintenance.
- ◆ Read and understand this operation manual carefully before assembling, operating or providing maintenance to the product.

■ Safety Instructions

Warning

- Do not disassemble, modify (including changing the printed circuit board) or repair.
An injury or failure can result.
- Do not operate or set with wet hands.
This may lead to an electric shock.
- Do not operate the product outside of the specifications.
Do not use for flammable or harmful fluids.
Fire, malfunction, or damage to the product can result.
Verify the specifications before use.
- Do not operate in an atmosphere containing flammable or explosive gases.
Fire or an explosion can result.
This product is not designed to be explosion proof.
- If using the product in an interlocking circuit:
 - Provide a double interlocking system, for example a mechanical system.
 - Check the product regularly for proper operation.Otherwise malfunction can result, causing an accident.
- The following instructions must be followed during maintenance:
 - Turn off the power supply.
 - Stop the air supply, exhaust the residual pressure and verify that the air is released before performing maintenance.Otherwise an injury can result.

 **Caution**

- When handling the unit or assembling/replacing units:
 - Do not touch the sharp metal parts of the connector or plug for connecting units.
 - Take care not to hit your hand when disassembling the unit.
The connecting portions of the unit are firmly joined with seals.
 - When joining units, take care not to get fingers caught between units.
An injury can result.

- After maintenance is complete, perform appropriate functional inspections.
Stop operation if the equipment does not function properly.
Safety cannot be assured in the case of unexpected malfunction.

- Provide grounding to assure noise resistance of the Fieldbus system.
Individual grounding should be provided close to the product with a short cable.

Fieldbus system/Industrial IoT Security Measures

With the introduction of Industrial IoT, various devices in a factory are connected to the network, and it is necessary to respond to new threats such as cyber-attacks. To protect Industrial IoT, it is important to take multilayered countermeasures (multilayer defense) that include IoT devices, networks, and cloud computing.

SMC recommends that the following countermeasures be considered. For details on the measures listed, please refer to the security measures documents and other documents issued by each country and organization.

(1) Do not connect devices to public networks such as the Internet.

If it is necessary to access equipment or the cloud through a public network, use a secure line such as a VPN or leased line.

Do not connect information networks such as offices to industrial IoT networks in factories.

(2) Install firewalls to prevent external threats from entering devices and systems.

Install routers and firewalls at network boundaries and set them to allow only the minimum necessary communication.

If a permanent connection is not required, disconnect the line by turning off communication devices when not in use.

(3) Make unused communication ports physically inaccessible or disable them in the configuration.

Check each port regularly to see if there are any unnecessary devices connected to the network equipment.

For various services (SSH, FTP, SFTP, etc.) of network devices, configure them to run only the necessary services.

Wireless LAN and other devices that use radio waves should be configured to have an appropriate propagation range and use appropriate devices that have been certified by the radio wave laws of the country in which they are installed.

Install equipment that outputs radio waves in a location where there is no interference from outside or inside the building.

(4) Set up a communication method with security measures such as data encryption.

Implement security measures with cryptographic functions in each environment, such as IoT networks and connections via secure gateways.

(5) Grant access privileges to each account and limit the number of users who can use the account.

Periodically review accounts and delete unused accounts and privileges.

If the number of login errors exceeds a certain threshold, set up an account lock mechanism, such as prohibiting the use of the account for a certain period of time.

(6) Protect passwords.

The initial passwords should be changed at the time of installation.

Change passwords on a regular basis.

The password should be a combination of characters that is difficult to guess and highly secure (e.g., 8 or more characters, including letters and special characters).

(7) Use the latest security software.

Install antivirus software on all PCs to detect and eliminate virus infection.

Anti-virus software should always be kept up-to-date.

(8) Keep the latest versions of equipment and system software.

Apply patches to keep OS and applications up-to-date.

(9) Monitor and detect abnormalities in the network.

In the event of an abnormality, monitor communications within the network and notify an alert when an abnormality is detected in order to promptly respond to the problem. Install devices such as intrusion detection/protection systems (IDS/IPS).

(10) Delete data when disposing of or relinquishing equipment.

When disposing of IoT devices, data deletion or physical destruction should be performed to prevent unauthorized use of data left on the devices.

Precautions regarding the Radio Law

Caution

Notice:

Changes or modifications not expressly approved by the manufacturer could void the user's authority to operate the equipment.

NOTE:

This equipment has been tested and found to comply with the limits for a Class A digital device, pursuant to Part 15 of the FCC Rules.

These limits are designed to provide reasonable protection against harmful interference when the equipment is operated in a commercial environment.

This equipment generates, uses, and can radiate radio frequency energy and, if not installed and used in accordance with the instruction manual, may cause harmful interference to radio communications.

Operation of this equipment in a residential area is likely to cause harmful interference in which case the user will be required to correct the interference at his own expense.

This device complies with Industry Canada's licence-exempt RSSs. Operation is subject to the following two conditions:

- (1) This device may not cause interference; and
- (2) This device must accept any interference, including interference that may cause undesired operation of the device.

Le présent appareil est conforme aux CNR d'Industrie Canada applicables aux appareils radio exempts de licence. L'exploitation est autorisée aux deux conditions suivantes:

- (1) l'appareil ne doit pas produire de brouillage, et
- (2) l'utilisateur de l'appareil doit accepter tout brouillage radioélectrique subi, même si le brouillage est susceptible d'en compromettre le fonctionnement.

Caution

When operating the product, please be sure to maintain a separation distance of at least 20 cm between your body (excluding fingers, hands, wrists, ankles and feet) and the product to meet RF exposure safety requirements as determined by FCC and Innovation, Science and Economic Development Canada. Installation of this device must ensure that at 20 cm separation distance is maintained between the device and end users.

警語

經型式認證合格之低功率射頻電機，非經許可，公司，商號或使用者均不得擅自變更頻率，加大功率或變更原設計之特性及功能。

低功率射頻電機之使用不得影響飛航安全及干擾合法通信；經發現有干擾現象時，應立即停用，並改善至無干擾時方得繼續使用。

前項合法通信，指依電信法規定作業之無線電通信。低功率射頻電機須忍受合法通信或工業，科學及醫療用電波輻射性電機設備之干擾。

■NOTE

- Follow the instructions given below when designing, selecting and handling the product.
 - The instructions on design and selection (installation, wiring, environment, adjustment, operation, maintenance, etc.) described below must also be followed.
 - *Product specifications
 - Use the specified voltage.
Otherwise failure or malfunction can result.
 - Reserve a space for maintenance.
Allow sufficient space for maintenance when designing the system.
 - Do not remove any nameplates or labels.
This can lead to incorrect maintenance, or misreading of the operation manual, which could cause damage or malfunction to the product.
It may also result in non-conformity to safety standards.
 - Beware of inrush current when the power supply is turned on.
Some connected loads can apply an initial charge current which will activate the over current protection function, causing the unit to malfunction.
 - Product handling
 - *Installation
 - Do not drop, hit or apply excessive shock to the SI unit.
Otherwise damage to the product can result, causing malfunction.
 - Tighten to the specified tightening torque.
If the tightening torque is exceeded the mounting screws may be broken.
IP67 protection cannot be guaranteed if the screws are not tightened to the specified torque.
 - If a large manifold valve is mounted, lift the unit so that stress is not applied to the connecting part while transporting.
The stress may cause breakage of the connecting part. The unit may become very heavy depending on the combination. Transportation/installation shall be performed by multiple operators.
 - Never mount a product in a location that will be used as a foothold.
The product may be damaged if excessive force is applied by stepping or climbing onto it.
 - *Wiring
 - Avoid repeatedly bending or stretching the cables, or placing heavy load on them.
Repetitive bending stress or tensile stress can cause breakage of the cable.
 - Wire correctly.
Incorrect wiring can break the product.
 - Do not perform wiring while the power is on.
Otherwise damage to the wireless unit and/or input or output device can result, causing malfunction.
 - Do not route wires and cables together with power or high voltage cables.
Otherwise the wireless unit and/or input or output device can malfunction due to interference of noise and surge voltage from power and high voltage cables to the signal line.
Route the wires (piping) of the wireless unit and/or input or output device separately from power or high voltage cables.
 - Confirm proper insulation of wiring.
Poor insulation (interference from another circuit, poor insulation between terminals, etc.) can lead to excess voltage or current being applied to the product, causing damage.
 - Take appropriate measures against noise, such as using a noise filter, when the Fieldbus system is incorporated into equipment.
Otherwise noise can cause malfunction.

*Environment

- Select the proper type of protection according to the environment of operation.

IP67 protection class is achieved when the following conditions are met.

(1) The units are connected properly with fieldbus cable with M12 connector and power cable with M12 (M8) connector.

(2) Suitable mounting of each unit and manifold valve.

(3) Be sure to fit a waterproof cap on any unused connectors.

If using in an environment that is exposed to water splashes, please take measures such as using a cover.

Do not use in an environment where moisture or water vapor are present. Otherwise failure and malfunction can result.

- Do not use in a place where the product could be splashed by oil or chemicals.

If the product is to be used in an environment containing oils or chemicals such as coolant or cleaning solvent, even for a short time, it may be adversely affected (damage, malfunction etc.).

- Do not use the product in an environment where corrosive gases or fluids could be splashed.

Otherwise damage to the product and malfunction can result.

- Do not use in an area where surges are generated.

If there is equipment generating large surge near the unit (magnetic type lifter, high frequency inductive furnace, welding machine, motor, etc.), this can cause deterioration of the internal circuitry element of the unit or result in damage. Take measures against the surge sources, and prevent the lines from coming into close contact.

- When a surge-generating load such as a relay, valve or lamp is driven directly, use a product with a built-in surge absorbing element.

Direct drive of a load generating surge voltage can damage the unit.

- The product is CE/UKCA marked, but not immune to lightning strikes. Take measures against lightning strikes in the system.

- Prevent foreign matter such as dust or wire debris from getting inside the product.

- Mount the product in a place that is not exposed to vibration or impact.

Otherwise failure or malfunction can result.

- Do not use the product in an environment that is exposed to temperature cycle.

Heat cycles other than ordinary changes in temperature can adversely affect the inside of the product.

- Do not expose the product to direct sunlight.

If using in a location directly exposed to sunlight, shade the product from the sunlight.

Otherwise failure or malfunction can result.

- Keep within the specified ambient temperature range.

Otherwise malfunction can result.

- Do not operate close to a heat source, or in a location exposed to radiant heat.

Otherwise malfunction can result.

*Adjustment and Operation

- Please refer to the I/O configuration manual for details of parameter settings.

- Perform settings suitable for the operating conditions.

Incorrect setting can cause operation failure.

(Refer to page 30 for the Setting and Adjustment.)

- Please refer to the PLC manufacturer's manual etc. for details of programming and addresses.

For the PLC protocol and programming refer to the relevant manufacturer's documentation.

*Maintenance

- Turn off the power supply, stop the supplied air, exhaust the residual pressure and verify the release of air before performing maintenance.

There is a risk of unexpected malfunction.

- Perform regular maintenance and inspections.

There is a risk of unexpected malfunction.

- After maintenance is complete, perform appropriate functional inspections.

Stop operation if the equipment does not function properly.

Otherwise safety is not assured due to an unexpected malfunction or incorrect operation.

- Do not use solvents such as benzene, thinner etc. to clean each unit.

They could damage the surface of the body and erase the markings on the body.

Use a soft cloth to remove stains.

For heavy stains, use a cloth soaked with diluted neutral detergent and fully squeezed, then wipe up the stains again with a dry cloth.

SMC Wireless System Features

The SMC wireless system has the following features:

- High-speed start up. The minimum connection time to the system after supplying power to the remote is 0.25 seconds. *1
- Parameter setting by Near Field Communication (NFC) using a PC (no HW setting).
- Up to 127 remote can be registered to one base. *2
- The maximum number of I/O points of the wireless system is 1280 for input and output. *3, 4
- The maximum number of I/O points of the base is 128 for input and output.
- The maximum number of I/O points of the remote is 128 for input and output.

*1: The base should be in the start upstate. The connection time varies depending on the timing of the power supply to the remote, the number of connected EX600 I/O units and other external influences.

*2: The maximum number of units that can be connected is 127. If 127 units is exceeded, the unit I/O will not be recognized. There might be a communication delay depending on the communication load status.

*3: The maximum number of I/O point is 1280 for input and output. When exceeding 1280 points, the unit I/O is not recognized. There might be a communication delay depending on the communication load status.

*4: The total number of I/O points of the base and the registered I/O points of the remote.

<Important >

- This product is a wireless unit in accordance with the Radio Act.

Be sure to comply with the following precautions.

- Do not disassemble or modify the product. Disassembly and modification are prohibited by law.
- This product is compliant with the Radio Act in Japan, European countries and the US. Refer to the product catalog or SMC website (URL <https://www.smcworld.com>) for the latest information.

*: If this product is to be imported into Malaysia (including if the product is integrated into other equipment), an SMC Wireless System Certificate of Compliance and a test report may be required in some cases. Please contact SMC for further details.

- This product communicates by radio waves, and the communication may stop instantaneously due to ambient environments and operating methods. SMC will not be responsible for any secondary failure which may cause an accident or damage to other devices or equipment.
- When several units are installed closely to each other, slight interference may occur due to the characteristics of the wireless product.
- The electromagnetic waves emitted from this product may interfere with implantable medical devices such as cardiac pacemakers and cardioverter defibrillators, resulting in the malfunction of the medical device or other adverse effects.

Please use extreme caution when operating equipment which may have an adverse effect on your implantable medical device. Be sure to thoroughly read the precautions stated in the catalog, operation manual, etc., of your implantable medical device, or contact the manufacturer directly for further details on what types of equipment need to be avoided.

- The communication performance is affected by the ambient environment, so please perform the communication testing before use.

SMC Wireless System Outline

■ Outline

This operation manual describes the **distributed I/O system** which can provide a wireless connection to the EX600 series with complete interchangeability.

It consists of a combination of the **base** which has upper level communication (EtherNet/IP™) and wireless connection function and the **remote** which offers wireless connection.

The base and remote can be constructed into **modules** by combining them with EX600 series I/O units.

Each base and remote is able to provide **up to 128 inputs and 128 outputs**, and up to 9 I/O units can be connected to each module.

Although the base is able to provide up to 128 inputs and 128 outputs as a base, it is possible to have up to 1280 inputs and 1280 outputs by matching the number of I/O points of the registered remote.

Therefore, the maximum number of I/O points per 1 node can be 1280 points (160 bytes)/1280 points (160 bytes) visible from the upper level communication such as a PLC.

It is possible to prevent malfunction when multiple base and remote are being operated in the same area by registering each PID (Product ID) of the base and the remote.

The packet of the wireless transmit and receive data is encrypted. It is therefore difficult to manipulate the data.

■ System configuration

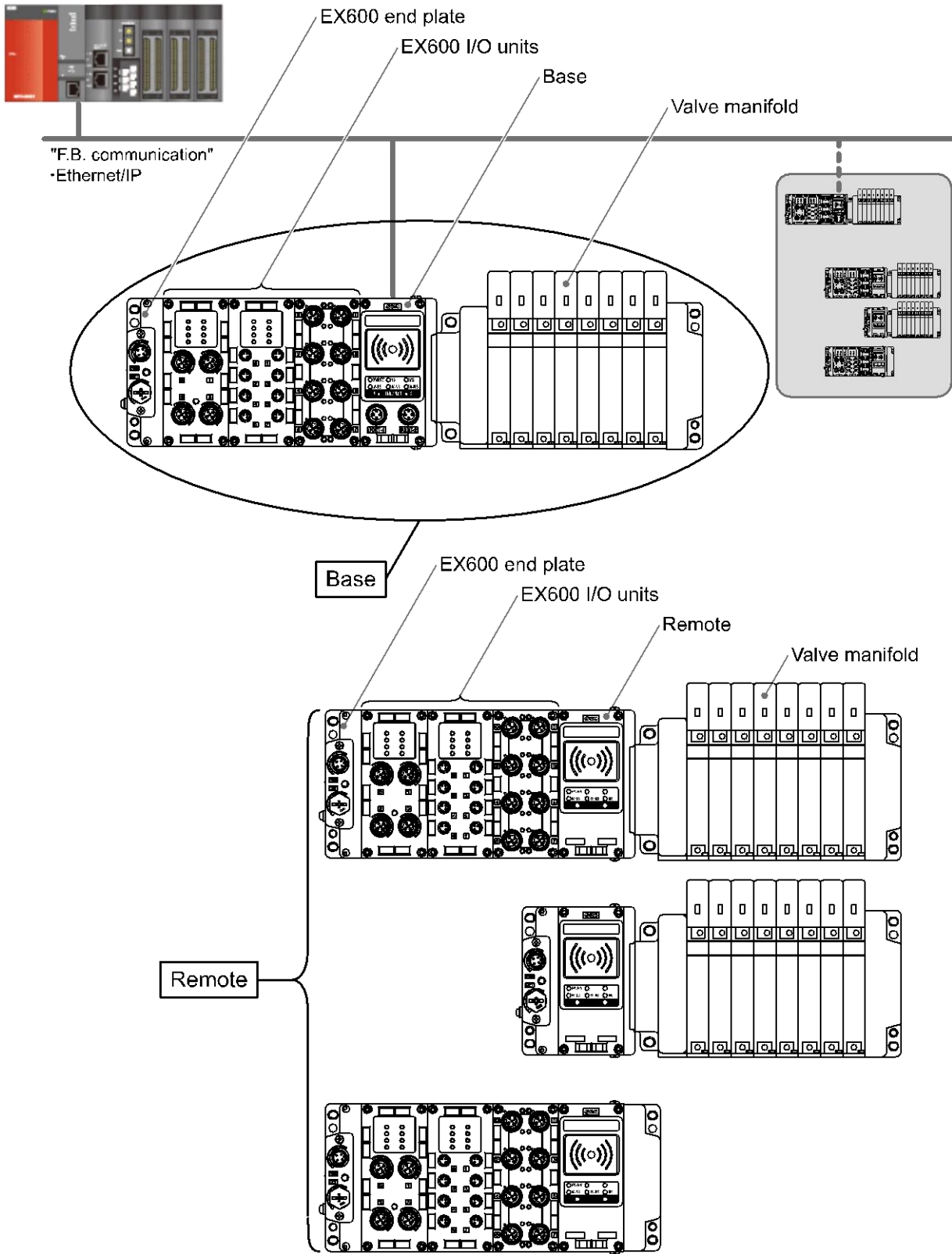

Wireless system configuration example

■Base

The construction of the base is shown below.

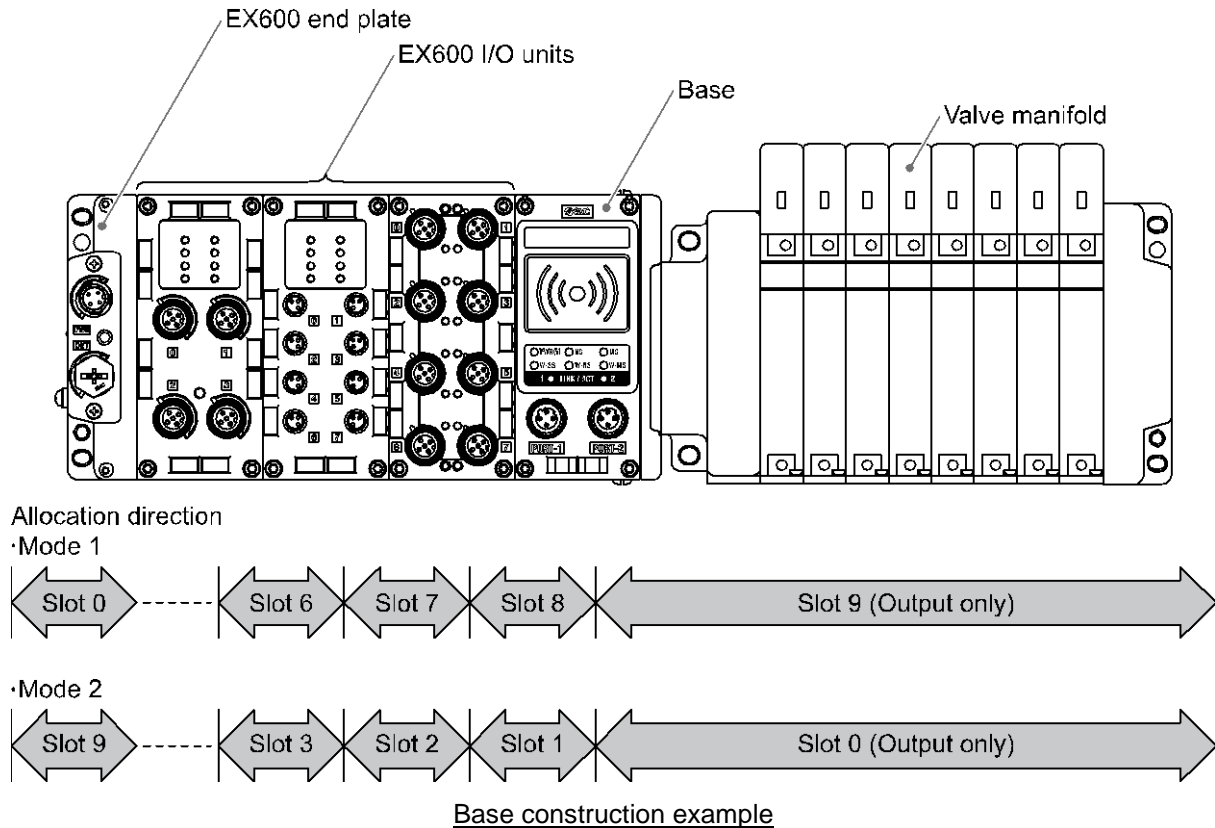

The **base** is positioned at the center of the **base**, so that the EX600 I/O units can be connected to the left side of the base and the valve manifold can be connected to the right side of the base. Refer to the SMC catalogue for the EX600 series serial transmission system for the wiring method. http://ca01.smcworld.com/catalog/BEST-5-1-en/mpv/e02-24-ex600/pageview.html#page_num=C1

The base transmits and receives the I/O unit information from the base and remote when connected to the upper level communication EtherNet/IP™ system.

With the wireless system the allocation direction of the address (Slot No.) setting allocated to the EX600 I/O unit and the connected valve manifold can be varied for each wireless unit. (Refer to page 37 the section "Setting and Adjustment" for details.)

■ Remote

The construction of the remote is shown below.

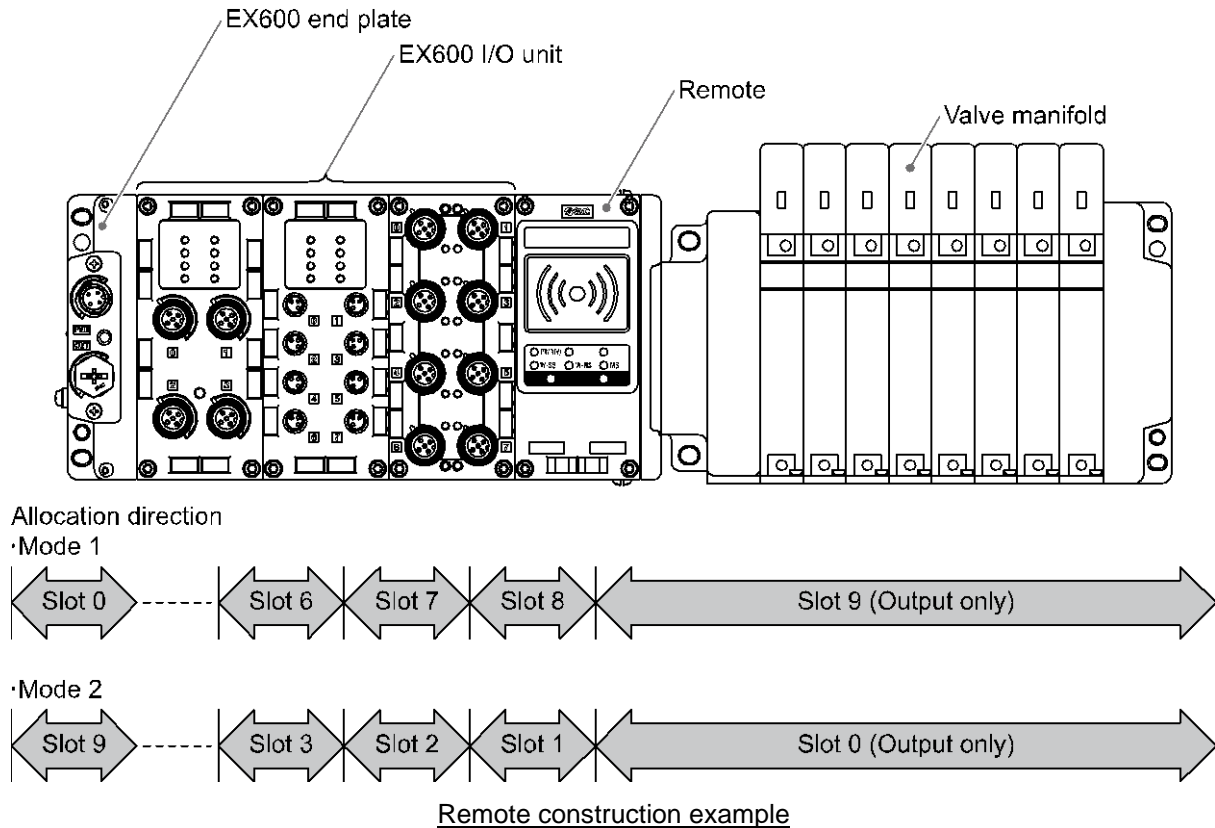

The remote is positioned at the center of the remote, so that the EX600 I/O units can be connected to the left side of the remote and the valve manifold can be connected to the right side of the remote, similar to the base.

Refer to the SMC catalogue for the EX600 series serial transmission system for the wiring method.
http://ca01.smcworld.com/catalog/BEST-5-1-en/mpv/e02-24-ex600/pageview.html#page_num=C1

The remote has a construction that is separated from the EtherNet/IP™ communication function by the base unit, and therefore it transmits/receives the information of the connected I/O units and valve manifold to/from the base.

With the wireless system the allocation direction of the address (Slot No.) setting allocated to the EX600 I/O unit and the connected valve manifold can be varied for each wireless unit.
 (Refer to page 43 the section "Setting and Adjustment" for details.)

■ Definition and terminology

	Term	Definition
100	100BASE-TX	Standard LAN transmission line with communication speed of 100 Mbps.
B	Base	A unit which establishes wireless communication of input or output data to the remote. It is connected to a PLC to establish communication of input or output data.
	Broken line detection	A broken wire to the input or output equipment has been detected by the diagnostic function.
C	Current consumption	Current which is necessary to operate each unit.
D	DHCP	A protocol that automatically allocates information, necessary to be registered to use the network, such as an IP address, to individual devices connected to the TCP/IP network.
	DIN rail	A metal rail conforming with the DIN (German) standard.
	DLR	DLR (Device level ring) protocol: a protocol which establishes communication continuously by providing a high speed recovery even when a communication error occurs somewhere on the ring network.
	D Side	The side connected to the end plate when the product is connected to a manifold.
E	EDS	Outer disc which stores configurable attribute information, such as object address of each parameter, related to the device.
	Enclosure (IP)	Abbreviation of International Protection. Standard related to protection against extraneous matter, such as hand, steel ball, steel wire, dust particle or water, applied to the product.
F	FE	Abbreviation of functional earth. The word "earth" refers to this functional earth.
	Fieldbus	Network protocol to establish digital communication between an automated industrial system such as a measurement tool or manipulation tool and a PLC.
	Full duplex	Communication system that can send and receive data at the same time bi-directionally.
H	Half-duplex	Communication method that can send and receive data reciprocally in bi-directional communication.
I	Idle	Base has received the FAIL SAFE command, and remains idle. The output state can be set to CLEAR, HOLD or Software Control using the parameter settings.
	IP address	A 32 bit digit sequence which is assigned to identify devices which are connected to the network.
M	MAC address	A unique number inherent to all devices connected to an EtherNet/IP™ network.
	Manifold	Aggregate.
N	NFC	Abbreviation of Near Field Communication. Non-contact short distance wireless communication. It is accessible using a card reader/writer by using a special application.
	NPN output	The output type that uses an NPN transistor to operate an output device. This is also known as a positive common type since a positive potential is applied to the power supply line.
	NPN input	Accepts a sensor output that uses the NPN transistor output signal.
	Number of inputs	Number of points which can receive information from input equipment such as a sensor or switch.
	Number of outputs	Number of points which can operate output equipment such as a valve, lamp or motor starter.

	Term	Definition
P	Paring	Registration of the PID (Product ID) of the remote to be connected to the base. Registration occurs at the initial setting, then wireless system will activate.
	PID	Abbreviation of Product ID. A 32 bit digit sequence which is assigned to identify the wireless unit (base/remote).
	PLC	Abbreviation of Programmable Logic Controller. A digital computer used for automation of electromechanical processes.
	PNP output	The output type that uses a PNP transistor to operate an output device. This is also known as a negative common type since a negative potential is applied to the power supply line.
	PNP input	Accepts a sensor output that uses the PNP transistor output signal .
Q	QuickConnect™	Function to shorten the time from initial operation of the equipment after supplying power to starting communication.
R	Remote	A unit which establishes wireless communication of input or output data to the base.
S	Short circuit detection	Diagnostic function which detects generation of over current due to a short circuit between the output and the positive power supply line or the ground line.
	Short circuit protection	Function which avoids damage to the internal circuit when over current is generated due to short circuit between the output and the positive power supply line or the ground line.
U	U side	The side connected to the valve manifold when the EX600 is connected to a manifold.
W	Wireless channel	Identification number of the remote connected to the base.
	Wireless system	This is a general term for the network including base and remote.
	Wireless unit	A unit which establishes wireless communication. This is a generic name of the base and remote.

Assembly

•Assembling the unit as a manifold

- (1) Connect a unit to the end plate.
Digital and analogue units can be connected in any order.
(Tightening torque: 1.5 to 1.6 Nm)

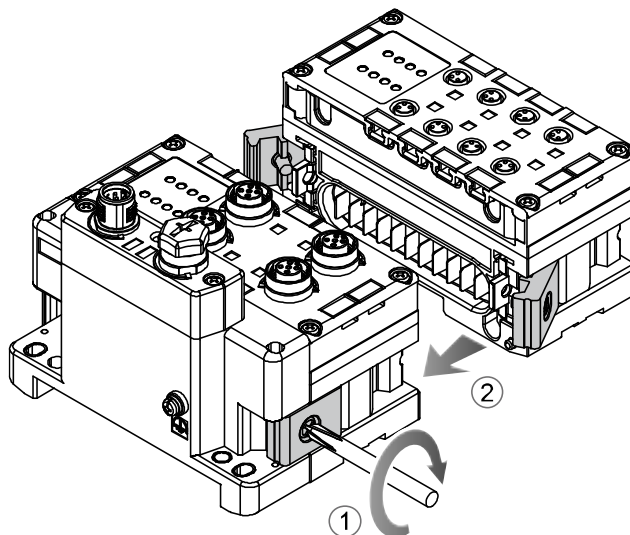

- (2) Add more units.
Up to 9 units can be connected to one manifold.

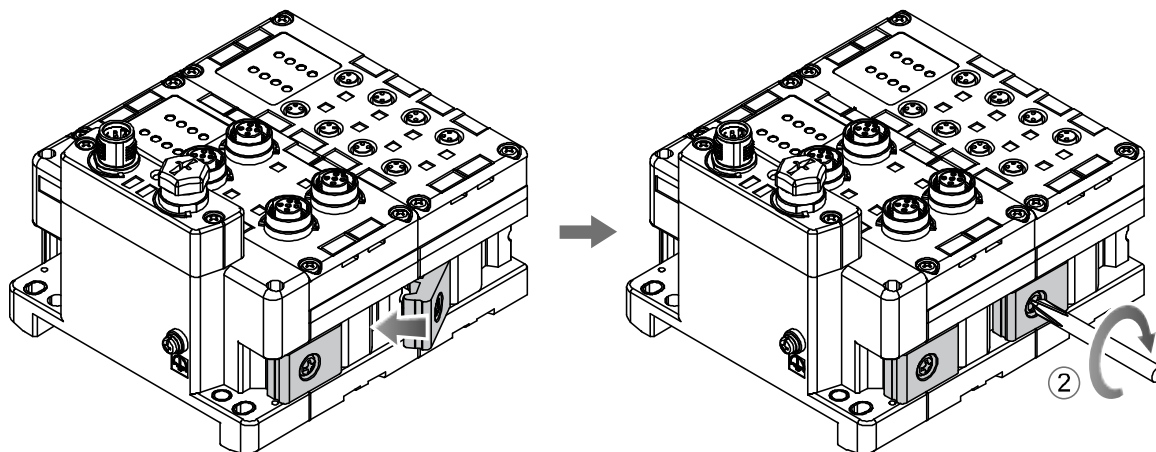

- (3) Connecting the wireless unit
After connecting the required I/O units, connect the wireless unit.
The connection method is as above.

(4) Mounting the valve plate. (Valve manifold not connected → Refer to page 20)

Mount the valve plate (EX600-ZMV#) to the valve manifold using the set screws (M3 x 8) provided with the product. (Tightening torque: 0.6 to 0.7 Nm)

Screw mounting
places

SV: 2 places

S0700: 2 places

VQC1000: 2 places

VQC2000: 3 places

VQC4000: 4 places

SY: 2 places

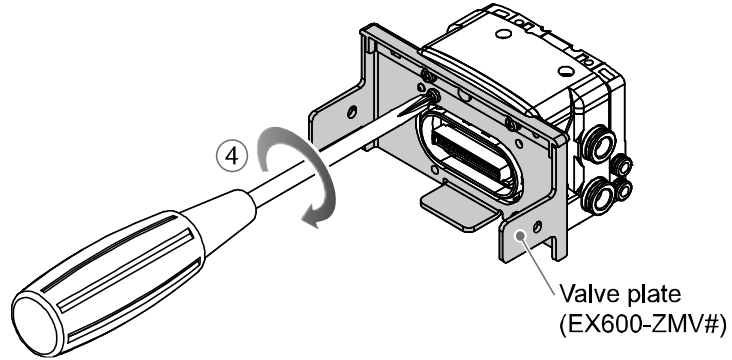

(5) Connect the wireless unit to the valve manifold.

Insert the valve plate into the valve plate mounting groove on the side of the wireless unit, and then fix both surfaces of the plate using the valve plate mounting screws (M4 x 6) provided with the product. (Tightening torque: 0.7 to 0.8 Nm)

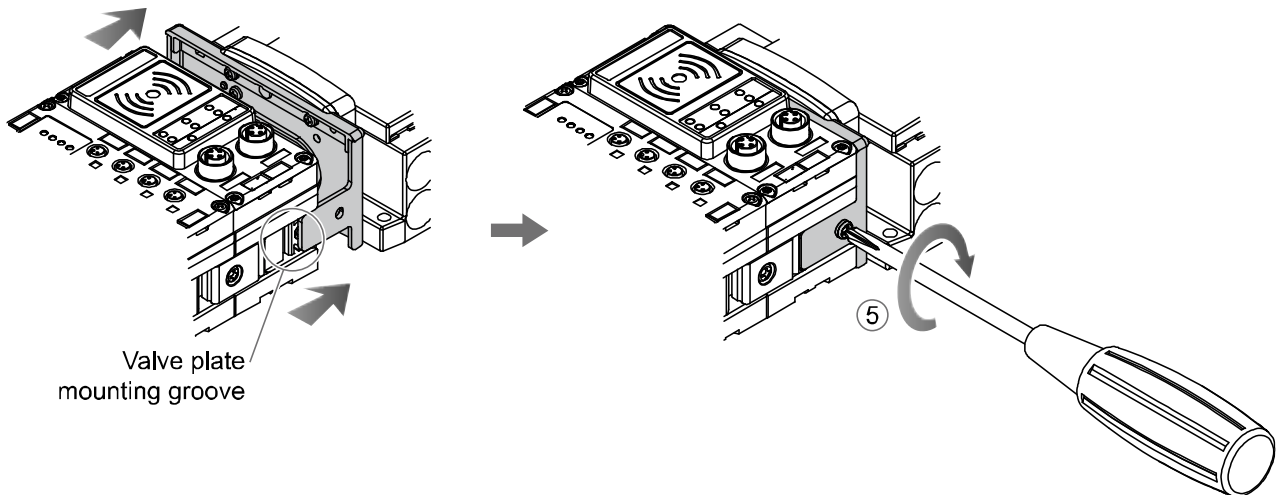

(6) When valve manifold is not connected.

Insert the end plate (EX600-EU1) into the valve plate mounting groove on the side of the wireless unit, and then fix both surfaces of the plate using the valve plate mounting screws (M4 x 6) provided with the product. (Tightening torque: 0.7 to 0.8 Nm)

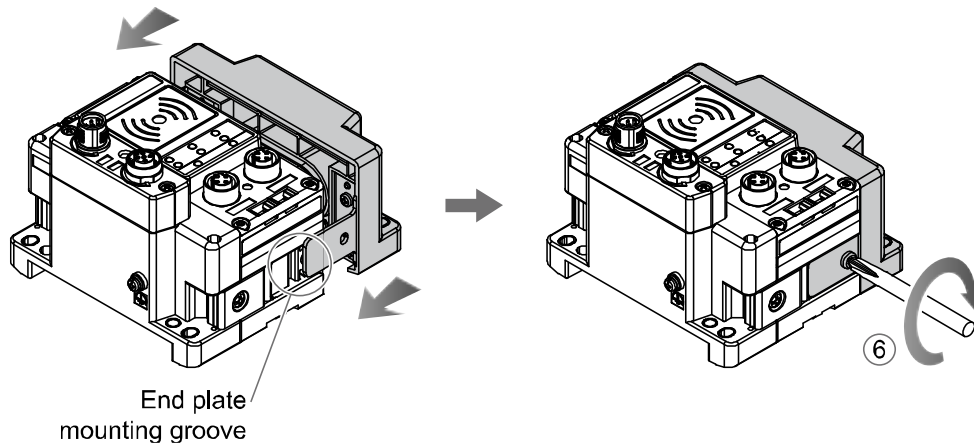

• Handling Precautions

- Do not connect units with power supplied.
- Be careful not to drop the nut for the joint bracket.
- Tighten the screws to the specified torque.
Insufficient tightening may lead to equipment malfunction, injury or equipment damage.

Mounting and Installation

■ Installation

• Direct mounting

- (1) When joining six or more units, fix the middle part of the complete EX600 unit with an intermediate reinforcing brace (EX600-ZMB1) before mounting, using 2-M4x5 screws. (Tightening torque: 0.7 to 0.8 Nm)

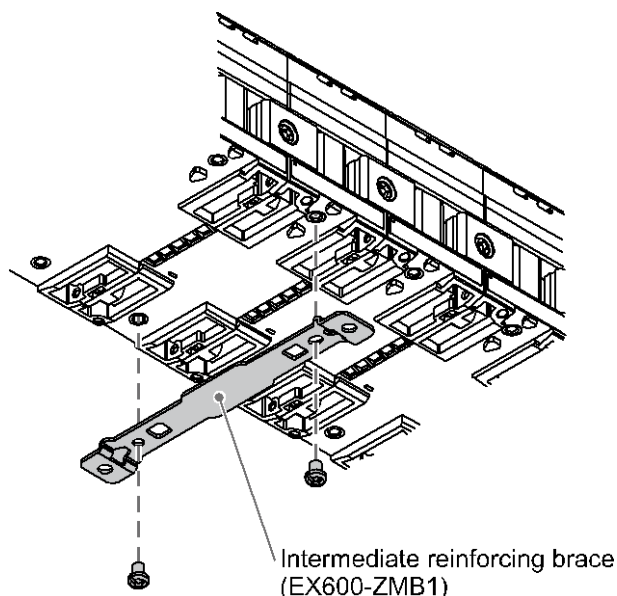

- (2) Mount and tighten the end plate and the valve manifold (intermediate reinforcing brace if necessary) at one end of the unit. (M4)
 (Tightening torque: 0.7 to 0.8 Nm)
 Refer to the Operation Manual of the applicable valve manifold for the mounting method of the valve side.

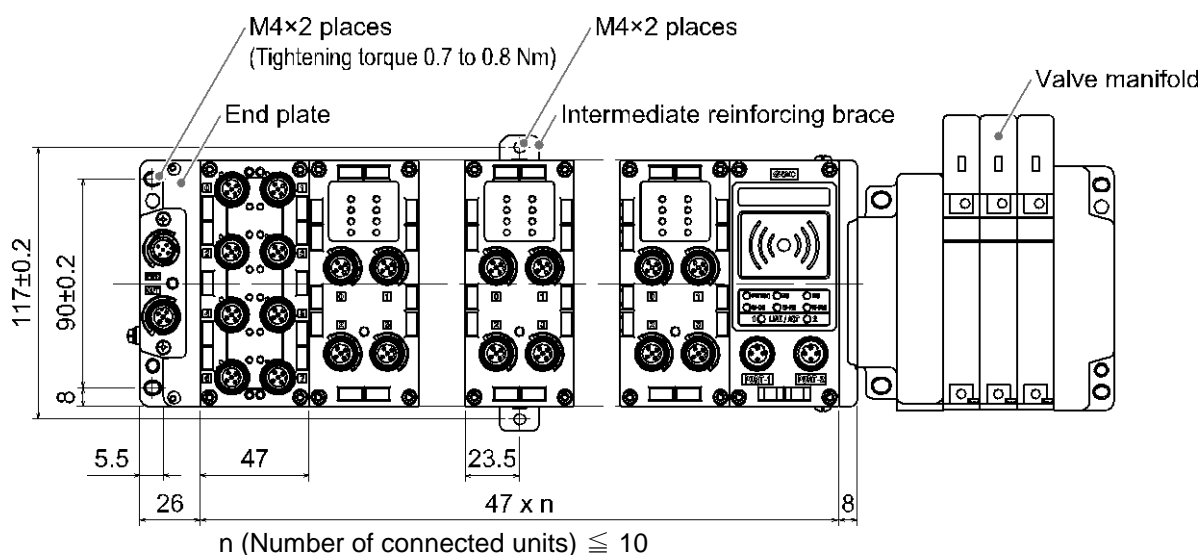

● Handling Precautions

- When joining six or more units, fix the middle part of the complete unit with an intermediate reinforcing brace to prevent incorrect connection between the units due to deflection.

•DIN rail mounting

- (1) When joining six or more units, fix the middle part of the complete EX600 unit with an intermediate reinforcing brace (EX600-ZMB2) for DIN rail before mounting, using 2-M4 x 6 screws.
(Tightening torque: 0.7 to 0.8 Nm)
- (2) Mount the end plate bracket (EX600-ZMA2) to the end plate using 2-M4 x 14 screws.
(Tightening torque: 0.7 to 0.8 Nm) For the SY series, use the end plate bracket (EX600-ZMA3).

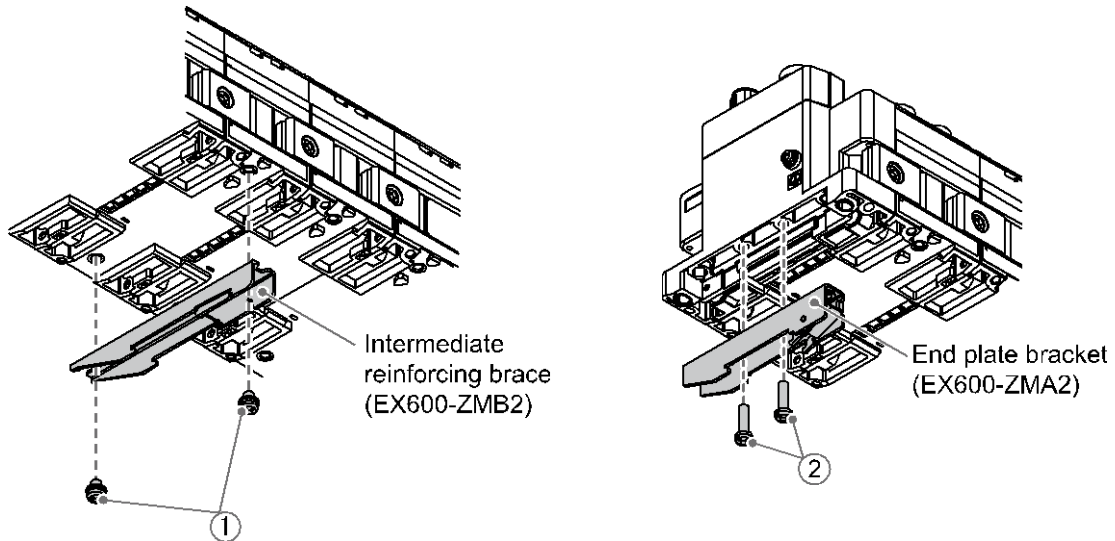

- (3) Hook the DIN rail mounting groove on to the DIN rail.
 - (4) Press the manifold using its side hooked to the DIN rail as a fulcrum until the manifold is locked.
 - (5) Fix the end plate bracket (EX600-ZMA2) to the manifold using the M4 x 20 screws provided with the product. (Tightening torque: 0.7 to 0.8 Nm)
- Refer to the Operation Manual of the applicable valve manifold for the mounting method of the valve side.

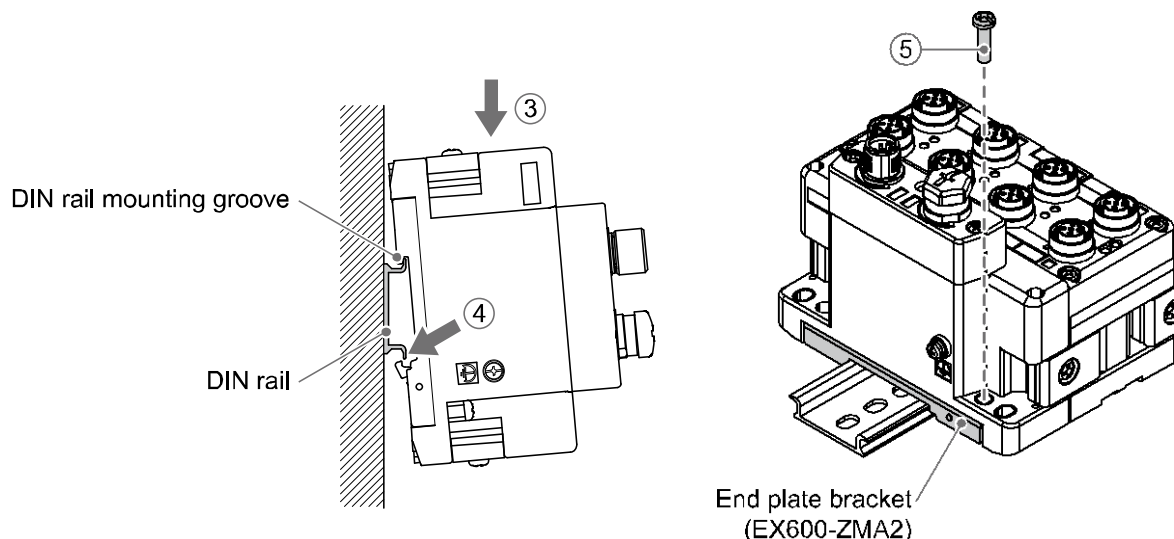

• Handling Precautions

- When joining six or more units, fix the middle part of the complete unit with an intermediate reinforcing brace to prevent incorrect connection between the units due to deflection.

•Mounting the marker

The signal name of the input or output devices and unit address can be written on the marker, and can be installed on each unit.

Mount the marker (EX600-ZT1) into the marker groove as required.

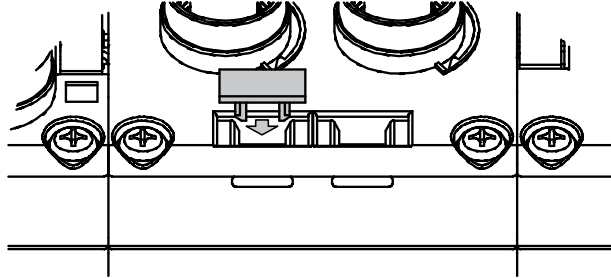

Model Indication and How to Order

•Base

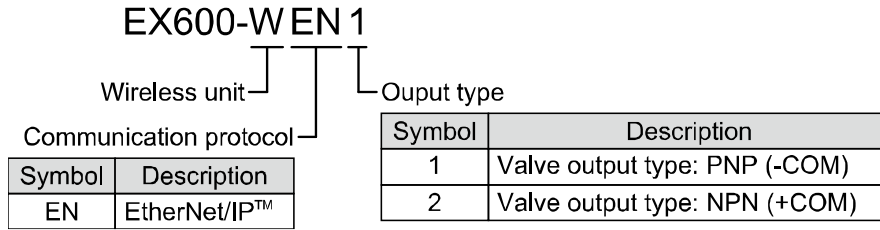

•Remote

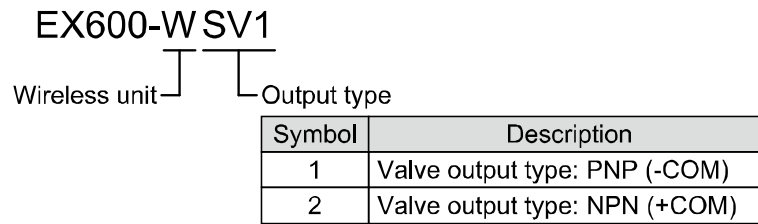

Summary of Product Parts

•Base

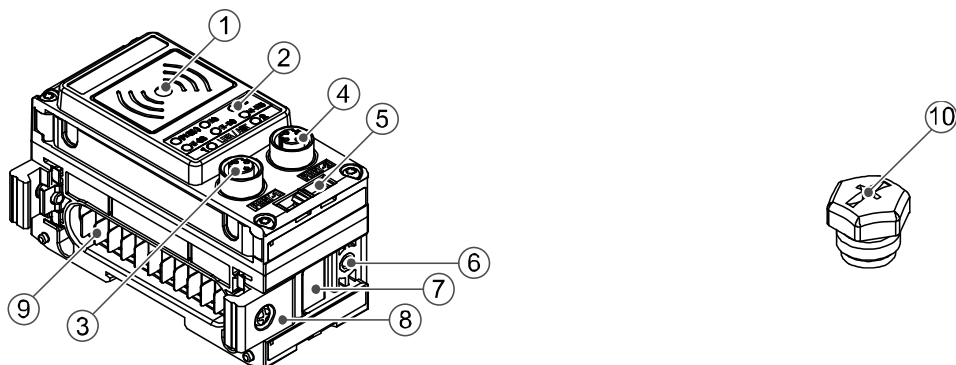

No.	Item	Application
1	Area close to NFC antenna	This area is in close contact with the NFC reader/writer. "O" is the center of the NFC antenna.
2	Status indication LED	LED display to indicate the unit status.
3	Connector (PORT-1)	Fieldbus input/output cable connection.
4	Connector (PORT-2)	Fieldbus input/output cable connection.
5	Marker groove	Marker(EX600-ZT1) can be mounted.
6	Screw hole for valve plate mounting	For fixing the valve plate.
7	Valve plate mounting groove	Groove to insert the valve plate.
8	Joint bracket	Bracket for mounting adjacent units.
9	Unit connector (plug)	Transfers signals to the next unit and supplies power.
10	Seal cap (1 pc.)	To be mounted on unused connectors (PORT 1 or PORT 2).

•Remote

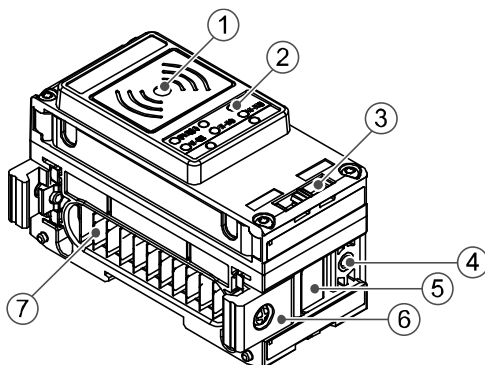

No.	Item	Application
1	Area close to NFC antenna	This area is in close contact with the NFC reader/writer. "O" is the center of the NFC antenna.
2	Status indication LED	LED display to indicate the unit status.
3	Marker groove	Marker(EX600-ZT1) can be mounted.
4	Screw hole for valve plate mounting	For fixing the valve plate.
5	Valve plate mounting groove	Groove to insert the valve plate.
6	Joint bracket	Bracket for mounting adjacent units.
7	Unit connector (plug)	Transfers signals to the next unit and supplies power.

■ Connector (Base only)

This system is operated using power supplied from the EX600-ED* end plate.
Refer to the end plate details for the power supply connection.

The base is connected to the upper level communication (Ethernet). The connector has 2 ports, PORT-1 and PORT-2, and both ports can connect to Ethernet.
The EtherNet/IP™ topology corresponds to star, line, tree and DLR (Device Level Ring).

•Connector pin No.

M12 4-pin Socket D code

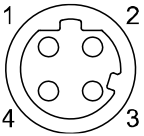
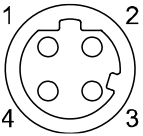
Connector		Pin No.	Signal name
PORT-1	PORT-2		
		1	TX+
		2	RX+
		3	TX-
		4	RX-

Ethernet connector of base

LED Display

■LED indication of base

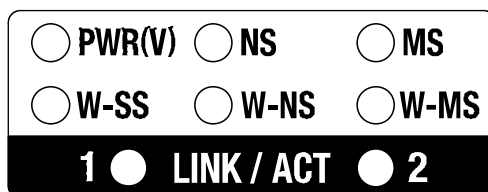

LED indication of base

•LED specifications of base

LED name	Function	Colour of LED	Operation
PWR (V)	Power supply voltage for output (US2)	Green LED is ON.	Power supply voltage for output (US2) is normal.
		Red LED flashes.	Power supply voltage for output (US2) is abnormal. (Indication only. The product can be operated) (Power Supply voltage monitor (Output) is valid)
		OFF	Power supply for control and input (US1) is not supplied.
NS	EtherNet/IP™ connection status *1	Green LED is ON.	EtherNet/IP™ communication is established.
		Green LED flashes.	EtherNet/IP™ communication is not established.
		Red LED flashes.	EtherNet/IP™ communication time out.
		Red LED is ON.	Duplicated IP addresses are detected.
		OFF	IP address not set.
MS	Base system status	Green LED is ON.	Base is normal.
		Green LED flashes.	EtherNet/IP™ communication is not connected.
		Red LED flashes.	Restorable error is detected. (LED flashes when more than one diagnostic information item is detected.) •Abnormal power supply voltage level for control and input (Power Supply voltage monitor (Control/Input) is valid) •Excessive I/O setting inputs/outputs •Analogue I/O upper and lower set limit exceeded •Analogue Input range upper and lower limit exceeded •Abnormal number of remote connections •Error in communication between units •EX600 I/O unit detects diagnostic information •Valve diagnostic information detected
		Red LED is ON.	Non-restorable error is detected. (e.g. Hardware failure)
		OFF	Power supply for control and input (US1) is not supplied.
		OFF	Power supply for control and input (US1) is not supplied.
W-SS	Radio wave receiving intensity (For communication from remote to base)	Green LED is ON.	Received power level of all remote is 3.
		Green LED flashes. (1 Hz)	There are connected remote with received power level 2.
		Green LED flashes. (2 Hz)	There are connected remote with received power level 1.
		Red LED flashes.	No remote connected.
		OFF	Remote is not registered.

LED name	Function	Colour of LED	Operation
W-NS	Wireless communication connection status	Green LED is ON.	All remote are connected correctly.
		Green LED flashes.	There are unconnected remote.
		Red LED flashes.	All remote are unconnected.
		Red LED is ON.	All remote are unconnected. (non-restorable error in wireless communication)
		Red/green	Wireless communication connection is under construction. (Pairing)
		Orange LED is ON.	Forced output mode.
		OFF	Remote is not registered.
W-MS	Remote connection system status	Green LED is ON.	Remote is normal.
		Red LED flashes.	Restorable error is detected (LED flashes when more than one diagnostic information item is detected) <ul style="list-style-type: none"> •Abnormal power supply voltage level for control and input (US1) •Abnormal power supply voltage level for output (US2) •Excessive I/O setting inputs/outputs •Analogue I/O upper and lower set limit exceeded •Analogue Input range upper and lower limit exceeded •Error in communication between units •EX600 I/O unit detects diagnostic information •Valve diagnostic information detected
		Red LED is ON.	Non-restorable error is detected. (e.g. Hardware failure)
		OFF	No remote connected.
LINK/ACT1 LINK/ACT2.	Communication status of EtherNet/IP™ ports 1 and 2	Green LED is ON.	Link, No Activity (100 Mbps)
		Green LED flashes.	Link, Activity (100 Mbps)
		Orange LED is ON.	Link, No Activity (10 Mbps)
		Orange LED flashes.	Link, Activity (10 Mbps)
	100 Mbps: Green 10 Mbps: Orange	Red LED is ON.	IP address has been duplicated.
	OFF	EtherNet/IP™ is not connected.	

*1: The LED indicator on the NS status is updated only when connected to the PLC/Web.

*: If there are multiple conditions for LED ON/Flashing, the detailed information can be seen only when the setting of the diagnostic information is "Simple" or "Detailed".

■ LED indication of remote

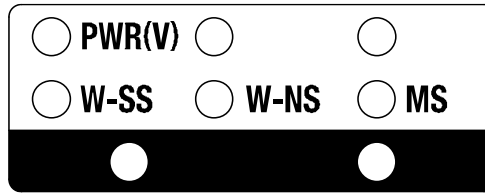

LED indication of remote

•LED Indication of remote

LED name	Function	Colour of LED	Operation
PWR (V)	Power supply voltage for output (US2)	Green LED is ON.	Power supply voltage for output (US2) is normal.
		Red LED flashes.	Power supply voltage for output (US2) is abnormal. (Indication only. The product can be operated) (Power Supply voltage monitor (Output) is valid)
		OFF	Power supply for control and input (US1) is not supplied.
W-SS	Radio wave receiving intensity (Communication from base to remote)	Green LED is ON.	Received power level is 3.
		Green LED flashes. (1 Hz)	Received power level is 2.
		Green LED flashes. (2 Hz)	Received power level is 1.
		Red LED flashes.	Wireless communication is not connected.
		OFF	Base is not registered.
W-NS	Wireless communication connection status	Green LED is ON	Remote is connected correctly.
		Red LED flashes.	No remote connected.
		Red LED is ON.	No remote connected. (non-restorable error in wireless communication)
		Red/green	Wireless communication connection is under construction. (Pairing)
		Orange LED is ON.	Forced output mode.
		OFF	Base is not registered.
MS	Remote system status	Green LED is ON.	Remote is normal.
		Red LED flashes.	Restorable error is detected. (LED flashes when more than one diagnostic information item is detected.) •Abnormal power supply voltage level for control and input (Power Supply voltage monitor (Control/Input) is valid) •Excessive I/O setting inputs/outputs •Analogue I/O upper and lower set limit exceeded •Analogue Input range upper and lower limit exceeded •Error in communication between units •EX600 I/O unit detects diagnostic information •Valve diagnostic information detected
		Red LED is ON.	Non-restorable error is detected. (e.g. Hardware failure)
		OFF	Power supply for control and input (US1) is not supplied.

*: If there are multiple conditions for LED ON/Flashing, the detailed information can be seen only when the setting of the diagnostic information is "Simple" or "Detailed".

Setting and Adjustment

■Flow chart for using the wireless system

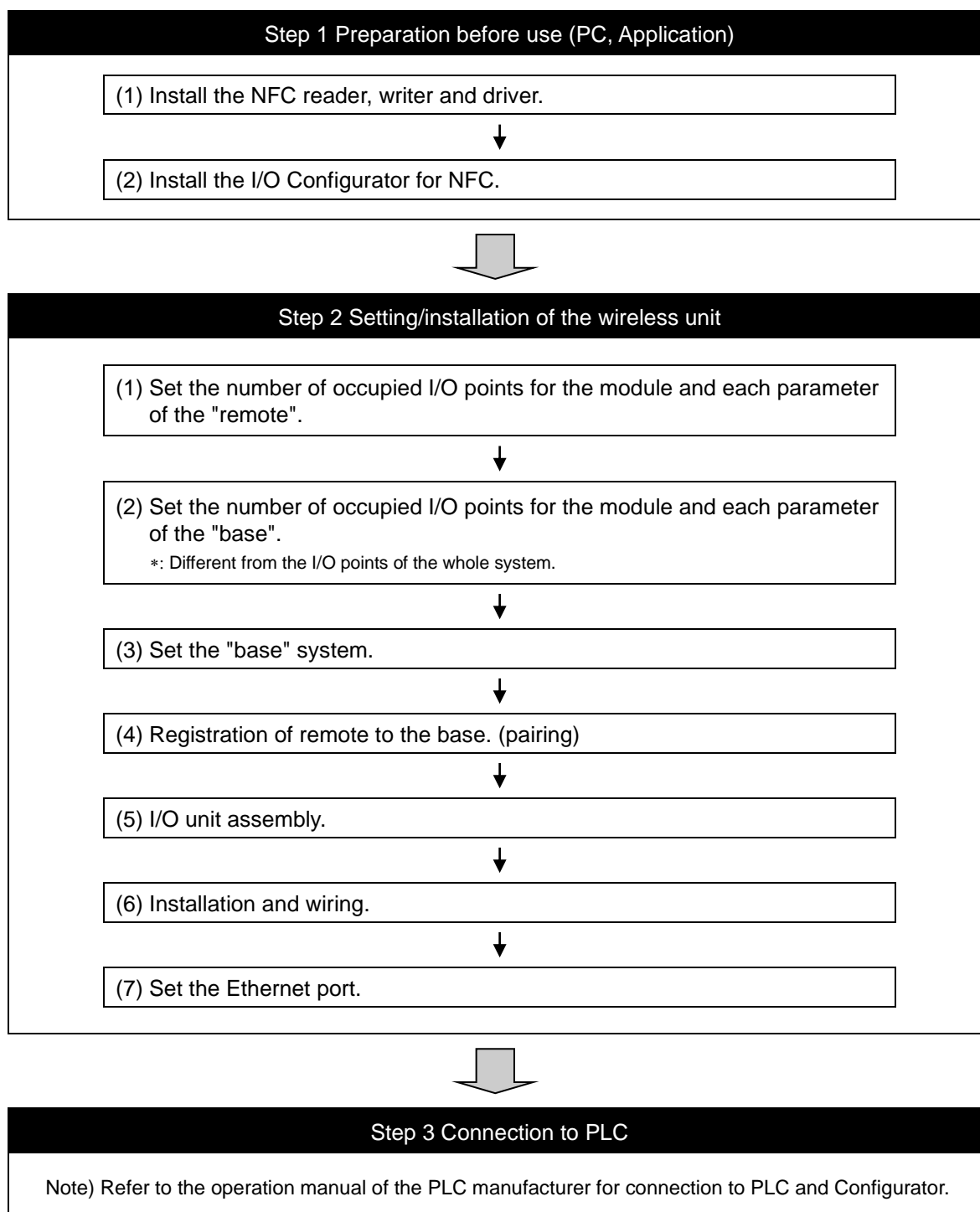

With the above settings, it is possible to control the upper level controller.

Refer to the operation manual for each manufacturer for how to set the controller and the PLC.

Refer to the I/O Configurator for NFC operation manual for details of the I/O Configurator.

■ Setting

• SMC wireless system I/O Configurator for NFC

The SMC wireless system I/O Configurator for NFC can be used to check the parameter setting of the wireless unit and the contents and status of the constructed wireless system, using an NFC reader/writer and a PC.

There are two types of settable parameters with the I/O Configurator: the parameters which can be read or written **when no power is supplied to the product** and the parameters which can be read or written **only when the power is supplied to the product**.

The connection details of the I/O Configurator for NFC and the wireless unit is shown in the below figure.

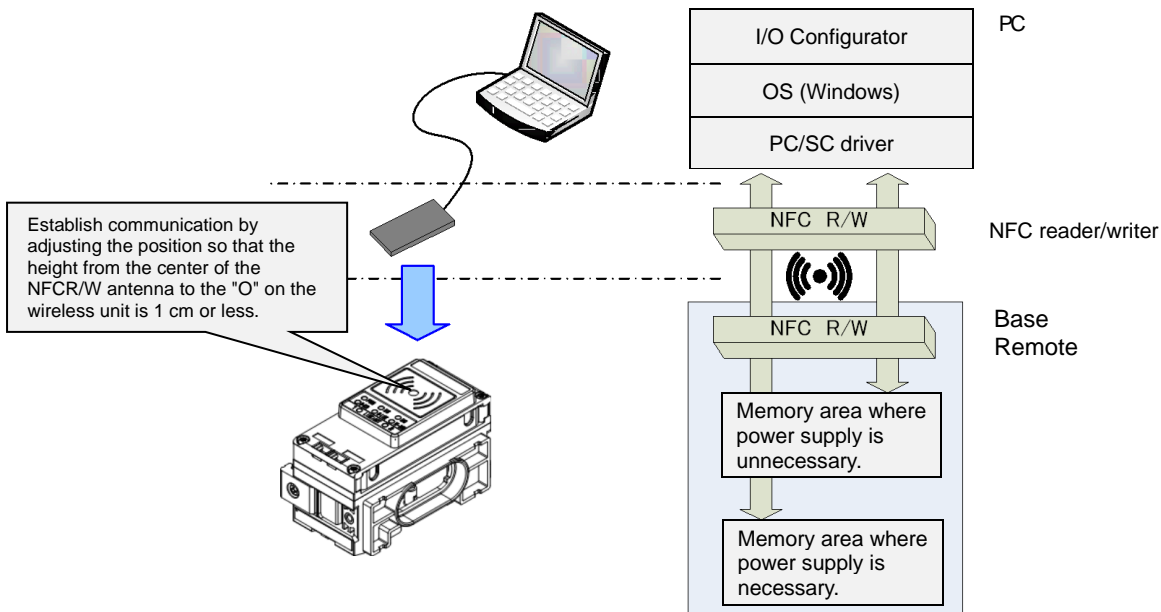

Connection details of the I/O Configurator for NFC and the wireless unit

To use the I/O Configurator for NFC, it is necessary to install a driver and set the NFC reader/writer on the PC beforehand.

Refer to the Operation Manual for the I/O Configurator for further details.

*: About the communication timing

The NFC communication is not accessed all the time. Therefore, it is necessary to update the contents displayed on the screen by clicking the "Refresh button" when reading the parameters. The parameters changed are valid after re-supplying the power supply or by pressing the reset button in the I/O Configurator screen. As the parameter setting requires time for settlement, do not turn off the power supply for 2 seconds.

*: Establishing communication after changing units

As the settings between the base and the remote are different, it is necessary to update the displayed parameter by clicking the "Refresh button" on the screen of the I/O Configurator for NFC after changing the unit in which the parameter is set.

*: Operation already checked. NFC reader/writer

Refer to the operation manual for the I/O Configurator (NFC version)

•Configuration of the I/O Configurator for NFC

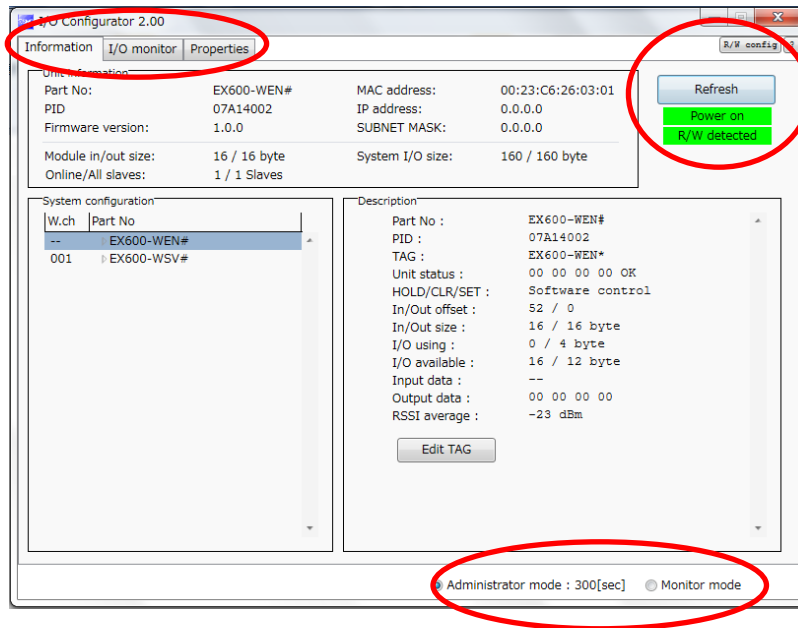

The I/O Configurator for NFC is mainly configured using the following three tabs.

Information tab

- Module information: shows information about the wireless unit.
- System configuration: shows the configuration information (connected units) of the base/remote. The system configuration of only the base is shown in a tree-like profile.
- Detailed information: shows detailed information about the unit selected in the system configuration.

Input/Output monitor tab

- Input: shows the input map information of the wireless unit.
- Output: shows the output map information of the wireless unit.

Setting tab

- Set item: Sets the parameter required to operate the base/remote.
- *: The contents of the setting tab is different between the base and the remote.
Refer to the wireless system parameter list for details.

The function of the upper right button of the "I/O Configurator (NFC)" is described below.

Refresh button

- Clicking the refresh button while holding the NFC reader/writer to the base and remote can reflect the setting of the base/remote on the I/O Configurator screen.

Power supply ON/OFF button

- "Power supply ON" is displayed when power is supplied to the base/remote, and "Power supply OFF" is displayed when power is not supplied.

R/W detection/ R/W no-detection button

- When the NFC reader/writer (R/W) is inserted into the USB port of the PC and the PC detects the NFC reader and writer, "R/W detected" is displayed. When the PC cannot detect it, "R/W undetected" is displayed.

NFC setting button

- When the NFC setting button is clicked, "NFC port/PaSoRI" is displayed on the setting screen.

The I/O Configurator for NFC has two modes: Administrator mode which can change the parameter setting and Monitor mode which can only read the parameter.

Administrator mode: available to read and write the parameters.

Monitor mode: available to read the parameter only. Writing parameter is not available.

Enter the correct password to enter administrator mode.

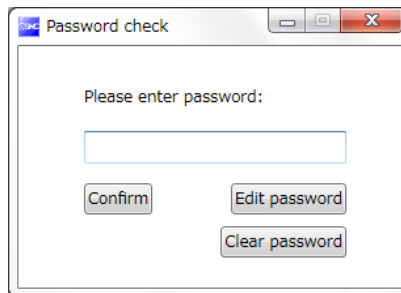

Default password: admin

If the password is forgotten, use the [Clear password] function. When the [Clear password] button is pressed, the password clear window will appear. The password will be cleared when the master factory key is entered. Then it is possible to enter administrator mode without inputting the password.

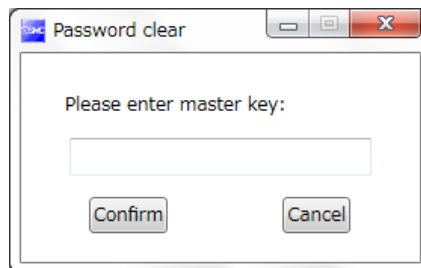

Master key: ADMIN

A password can be set using Administrator mode to prevent mischievous action by others. It is recommended to change the password at the time of first accessing.

•Wireless system parameter list

•Base setting parameters

Classification	Parameter name	Set value	Default	Setting when not energized	Note
Base setting	a) Hold/Clear (unit)	Clear/Hold/Software control	CLEAR	Available	Setting of output operation status when EtherNet/IP™ communication is disconnected.
	b) Input size	0 to 128 points (0 to 16 bytes) Increase and decrease by 16 points.	128 points/ 16 byte	Available	
	c) Output size	0 to 128 points (0 to 16 bytes) Increase and decrease by 16 points.	128 points/ 16 bytes	Available	
	d) Valve manifold output size	0 to 32 points (0 to 4 bytes) Increase and decrease by 8 points.	32 points/ 4 bytes	Available	The valve output size is included in the output size of each station. The number of effective points is limited within the set range of the output size.
	e) Wireless communication	Active/Idle	Active	Available	If it is set to "Idle", the wireless communication is disconnected.
	f) Unit address order	Mode 1/ Mode 2	Mode 1	Available	Mode 1: Allocation to the right from the end plate. Mode 2: Allocation to the left from the wireless unit.
Ethernet setting	a) IP address type	Manual/BOOTP, DHCP	Manual	Available	The IP address can be input manually only when "Manual" is selected.
	b) Auto MDI/MDI-X	Auto MDI/MDI-X	Auto	Available	
	c) Duplex	Full duplex/Half duplex	Full duplex	Available	
	d) Speed	Auto/100 Mbps/10 Mbps	Auto	Available	
System setting	a) I/O mapping	Auto mapping/fixed mapping	Fixed mapping	Available	When the total size (byte) of the I/O mapping is an odd number, 1 byte will be added automatically so that an even number will be allocated.
	b) System input size	16 to 1280 points (2 to 160 bytes) Increase and decrease by 128 points.	1280 points/ 160 byte	Available	This is not settable when the I/O mapping is set to "Auto".
	c) System output size	16 to 1280 points (2 to 160 bytes) Increase and decrease by 128 points.	1280 points/ 160 byte	Available	This is not settable when the I/O mapping is set to "Auto".
	d) Diagnostic allocation	None/Simple/Detailed	Detailed	Available	Diagnostic information is allocated to the head of the input data of the I/O map.
	e) Max remote	0/15/31/63/127 pcs.	15 pcs.	Available	The wireless channel equivalent to the number of set units is valid.
	f) DA refresh time	0.1/0.2/0.5/1/2/5/ 10/30/60s	1s	Available	Set the sampling frequency of the analogue output equipment.

Classification	Parameter name	Set value	Default	Setting when not energized	Note
Remote registration	a) Pairing	Pairing disable/Pairing enable	Pairing disable	Available	Pairing disable: Remote cannot be registered (wireless communication to the registered remote will be established). Pairing enable: Remote can be registered.
	b) Remote registration	Allocation and registration of the remote to the wireless channel.	No remote registered	Not available	
	c) Dummy	Addition of dummy remote to the wireless channel	Dummy remote unset	Not available	Refer to dummy remote registration for details setting.

•Remote setting parameters

Classification	Parameter name	Set value	Default	Setting when not energized	Note
Remote setting	a) Hold/Clear (unit)	Clear/Hold/Software control	Clear	Available	Setting of output operation status when EtherNet/IP™ communication is disconnected.
	b) Input size	0 to 128 points (0 to 16 bytes) Increase and decrease by 16 points.	128 points/ 16 bytes	Available	
	c) Output size	0 to 128 points (0 to 16 bytes) Increase and decrease by 16 points.	128 points/ 16 bytes	Available	
	d) Valve manifold output size	0 to 32 points (0 to 4 bytes) Increase and decrease by 8 points.	32 points/ 4 bytes	Available	The valve output size is included in the output size of each station. The number of effective points is limited within the set range of the output size.
	e) Wireless communication	Active/Idle	Active	Available	If it is set to "Idle", the wireless communication is disconnected.
	f) AD refresh time	0.1/0.2/0.5/1/2/5/ 10/30/60s	1s	Available	Set the sampling frequency of the analogue input equipment.
	g) Unit address order	Mode 1/ Mode 2	Mode 1	Available	Mode 1: Allocation to the right from the end plate. Mode 2: Allocation to the left from the wireless unit.
Pairing setting	a) Pairing	Pairing disable/Pairing enable	Pairing disable	Unavailable	Pairing disable: Remote cannot be registered (wireless communication to the registered remote will be established). Pairing enable: Remote can be registered.

•Common parameter of base and the remote

Classification	Parameter name	Set value	Default	Setting when not energized	Note
Information	TAG	Max. 15 letters	Product No. (EX600-WEN#)	Available	Letters which can be input are half-width characters (alphabets, numbers, symbols) that correspond to ASCII code. It is not possible to write to the remote during a non-energized state.
			Product No. (EX600-WSV#)		

•Detailed base parameters

The following four settings need to be performed to set the parameters of the base.

- (1) Base setting
- (2) Ethernet setting
- (3) System setting
- (4) Remote registration

(1) Base setting

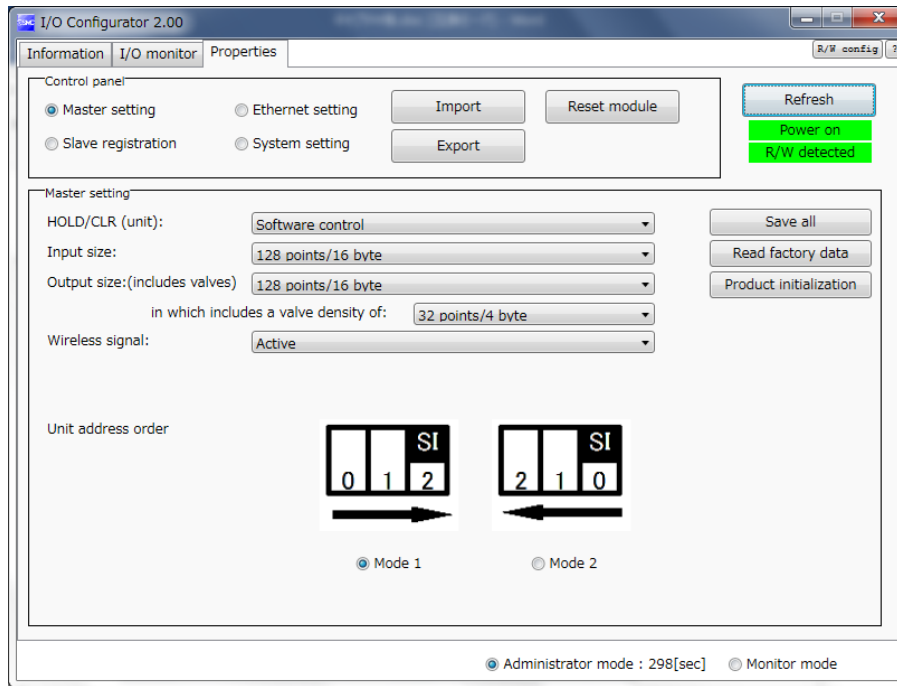

a) Hold/Clear (unit)

Define all settings in the output operation status when the EtherNet/IP™ communication is disconnected.

CLEAR: Clear the output.

HOLD: Fix the output at the current value.

Software control: Clear, Hold or Set can be set by software bit.

(The detailed setting of the Software control can be performed using the I/O Configurator for NFC.)

*: When wireless communication is disconnected, the input and output operation status is fixed to HOLD.

b) Input size

Set the number of inputs which can be controlled by the base.

Setting range: 0 to 128 points (0 to 16 bytes). Increase or decrease by 16 points.

c) Output size

Set the number of outputs which can be controlled by the base.

Setting range: 0 to 128 points (0 to 16 bytes). Increase or decrease by 16 points.

The output size includes the number of points of the valve manifold output.

d) Valve manifold output size

Set the number of outputs to be allocated to the valve manifold output from the number of points set in the Output size.

As the Valve manifold output size is included in the Output size, the number of effective points are limited within the setting range of the Output size.

Setting range: 0 to 32 points (0 to 4 bytes). Increase or decrease by 8 points.

e) Wireless communication

Define the operation status of wireless communication.

Active: Implement the wireless communication.

Idle: Disconnect the wireless communication.

f) Unit address order

Define the address allocation direction of the EX600 I/O units connected to the base.

The address allocation direction is selected by changing the mode to Mode 1 or Mode 2. Be careful about the I/O map. (Refer to the section "I/O Map" for details.)

Mode 1: Allocation from the end plate side to the right.

Mode 2: Allocation from the wireless unit side to the left.

(2) Ethernet setting

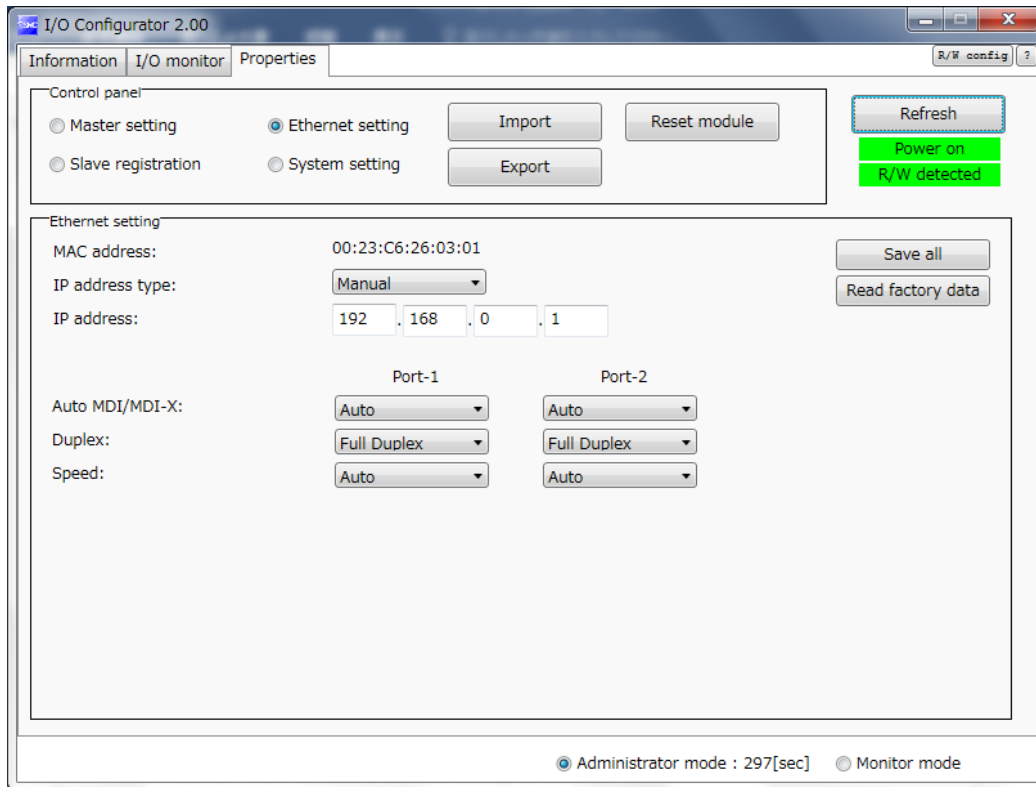

a) IP address type

Select the IP address setting mode. Select the mode suitable for your network environment.

Manual: The IP address is set by inputting it directly.

(The IP address is valid only when "Manual" mode is selected.)

BOOTP, DHCP: The IP address is set automatically via the DHCP server.

b) Auto MDI/MDI-X

Select settings for straight cable or crossed cable. Select the settings suitable for your environment.

Setting range: Auto/MDIX/MDI

c) Duplex

Set the Duplex. Select the Duplex suitable for your environment.

Setting range: Full Duplex/Half Duplex

d) Speed

Set the communication speed. Select the speed suitable for your environment.

Setting range: Auto/100 Mbps/10 Mbps

(3) System setting

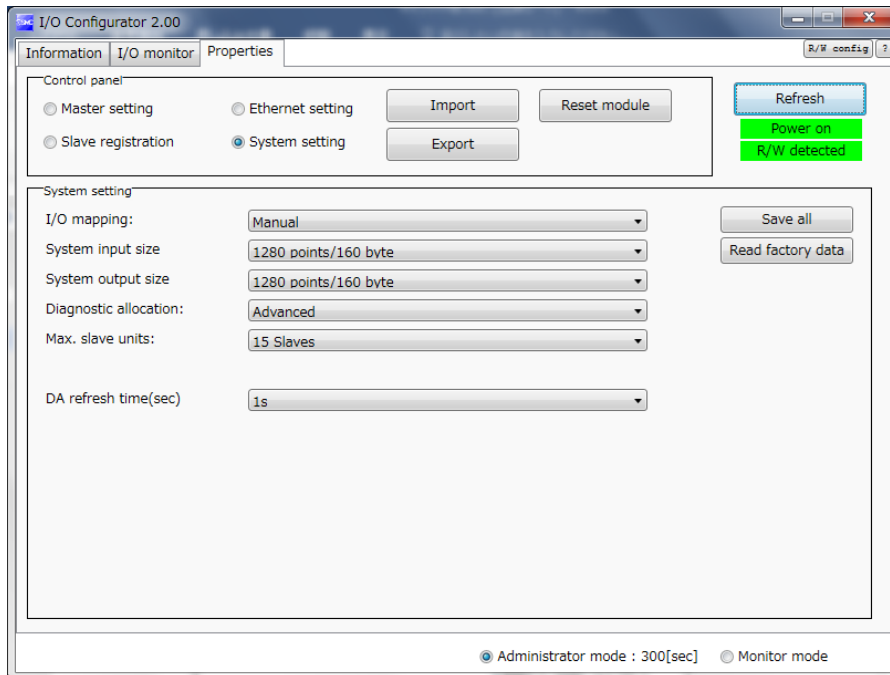

a) I/O mapping

Define the I/O mapping of the entire wireless system including the remote registered to the base.

Auto mapping: All I/O points mapped to the base and remote are identified and mapped automatically.

(The total number of connected I/O points is the total number of I/O points connected to the diagnostic information, base and remote.)

Fixed mapping: Fixed at the number of I/O points set in the System input size and System output size.

b) System input size

Set the number of inputs which can be controlled by the entire wireless system.

Setting range: 16 to 1280 points (2 to 160 bytes). Increase or decrease by 128 points.

c) System output size

Set the number of outputs which can be controlled by the entire wireless system.

Setting range: 16 to 1280 points (2 to 160 bytes). Increase or decrease by 128 points.

d) Diagnostic allocation

Set the diagnostic information allocated to the I/O map. (Refer to the section "Diagnostic allocation" for details.)

None: No diagnostic data

Simple: System diagnosis

Detailed: System diagnosis + Remote connection/diagnosis/registration information

e) Max remote

Set the number of remote which are registered to the base.

Wireless channels for the number of the set units are valid.

Setting range: 0/15/31/63/127 pcs.

f) DA refresh time

Analogue output update time

Set the data update time of the analogue output unit.

Setting range: 0.1/0.2/0.5/1/2/5/10/30/60s

Note) Analogue I/O unit

This product is applicable to the analogue I/O unit.

The initial setting of the update time is 1 second for input and output respectively.

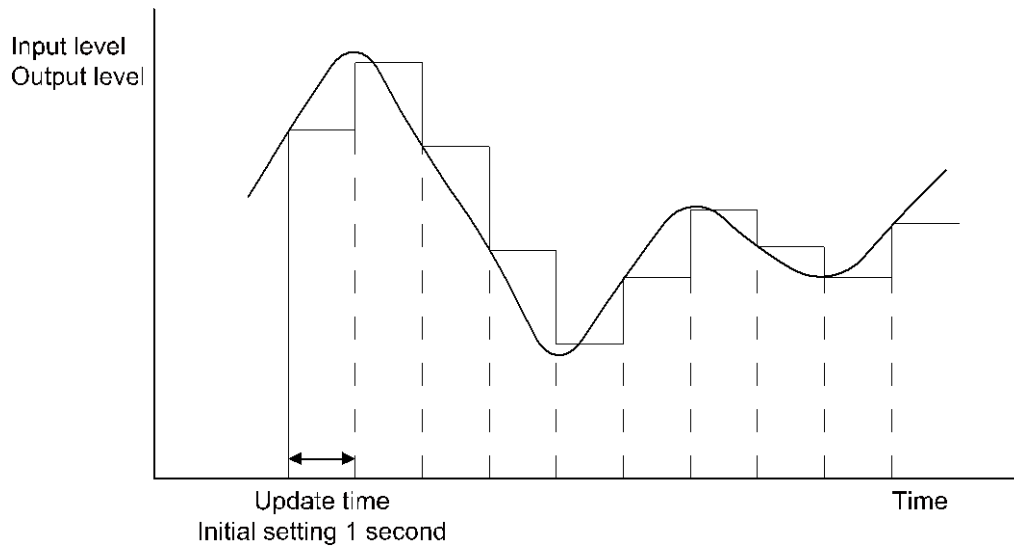

(4) Remote registration

Registration for wireless communication between the base and the remote.

For this wireless system, it is necessary to register the PID (Product ID) of each product to establish communication without interference from another network.

The minimum required settings for registration of the base are pairing (change of operation mode) and remote registration.

Wireless communication can be established even if the dummy remote is not registered. Register the dummy remote as necessary.



- After changing the operation mode in the Pairing, the mode is changed by clicking **Reset module** or by re-supplying power so that the mode will be changed to "Remote registration" or "Listening for connection".

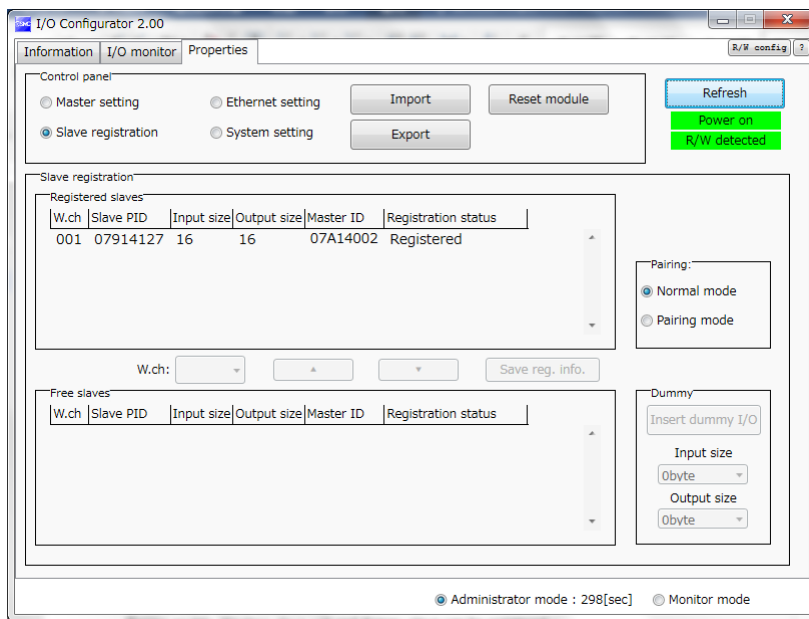

a) Pairing

Select operation mode of the base.

The remote can be registered only when "Pairing enable" is selected.

Pairing disable: Remote cannot be registered (Communication with the registered remote will be established).

Pairing enable: Remote and dummy remote can be registered.

b) Remote registration

Register and delete the remote to/from the base; and check the registration status of the remote. Refer to remote registration procedure for details.

c) Dummy

Register the dummy remote to the wireless channel.

Refer to remote registration procedure for details.

•Detailed remote parameters

The following two settings need to be performed to set the parameters of the remote.

- (1) Remote setting
- (2) Pairing setting

(1) Remote setting

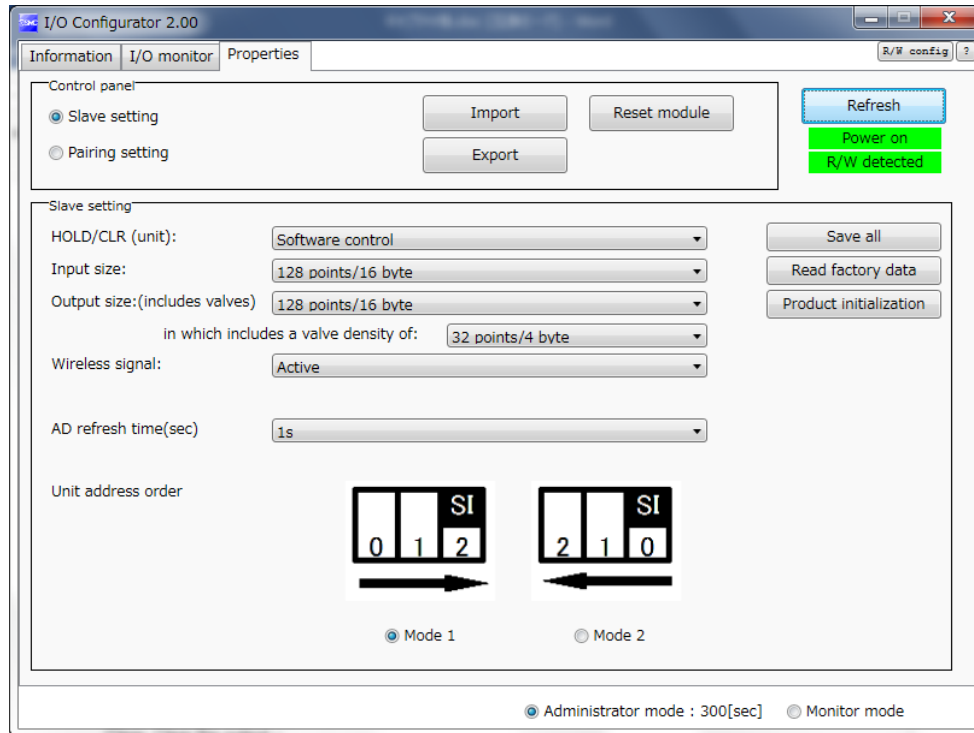

a) Hold/CLR (unit)

Define settings for the output operation status when the EtherNet/IP™ communication is disconnected.

Clear: Clear the output.

Hold: Fix the output at the current value.

Software control: Clear, Hold or Set can be set by software bit.

(The detailed setting of the Software control can be performed using the I/O Configurator for NFC.)

*: When wireless communication is disconnected, the input and output operation status is fixed to HOLD.

b) Input size

Set the number of inputs which can be controlled by the remote.

Setting range: 0 to 128 points (0 to 16 bytes). Increase or decrease by 16 points.

c) Output size

Set the number of outputs which can be controlled by the remote.

Setting range: 0 to 128 points (0 to 16 bytes). Increase or decrease by 16 points.

d) Valve manifold output size

Set the number of outputs to be allocated to the valve manifold output from the number of points set in the Output size.

As the Valve manifold output size is included in the Output size, the number of effective points are limited within the setting range of the Output size.

Setting range: 0 to 32 points (0 to 4 bytes). Increase or decrease by 8 points.

e) Wireless communication

Define the operation status of wireless communication.

Active: Implement the wireless communication.

Idle: Disconnect the wireless communication.

f) AD refresh time

Set the data update time of the analogue input unit.

Setting range: 0.1/0.2/0.5/1/2/5/10/30/60s

g) Unit address order

Define the address allocation direction of the EX600 I/O units connected to the remote.

The address allocation direction is selected by changing the mode to Mode 1 or Mode 2. Be careful about the I/O map.

Mode 1: Allocation from the end plate side to the right.

Mode 2: Allocation from the wireless unit side to the left.

(2) Pairing setting

Setting for wireless communication between the base and remote.

The required setting for wireless registration of the remote is Pairing (change of operation mode) only.

After changing the operation mode in the Pairing, the mode is changed by clicking Reset module or by re-supplying power so that the mode will be changed to "Base registration" or "Listening for connection".

* : After switching the operation mode with the Pairing setting, check that the W-NS LED on the wireless unit flashes in green and red alternately.

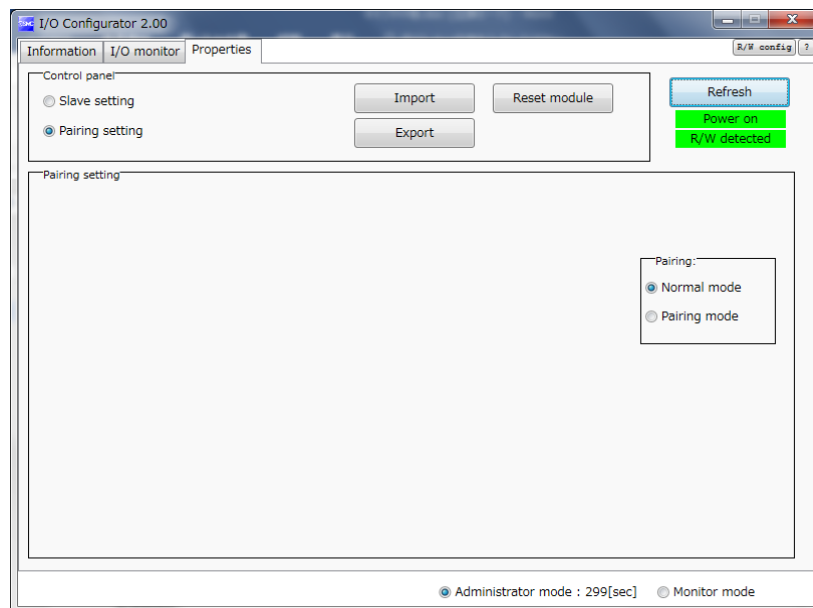

a) Pairing

Select the operation mode of the remote.

The base can be registered only when "Pairing enable" is selected.

Pairing disable: Remote cannot be registered.

(Communication with the registered remote will be established)

Pairing enable: Remote and reserve remote can be registered.

•Wireless unit registration procedure

•Registration procedure for the base and the remote

(1) **Change of operation mode** of the remote

Change the pairing setting of the remote to "Pairing enable" and reflect the change by clicking **Reset module** or by re-supplying power.

(2) **Change of operation mode** of the base

Change the pairing setting of the remote registration of the base to "Pairing enable" and reflect the change by clicking **Reset module** or by re-supplying power. Then, update the contents on the screen by clicking **Refresh all**.

(Registered remote information will be displayed in the free remote.)

(3) **Selection of wireless channel**

Select the required wireless channel in the remote setting of the base and select the remote to be registered so that items in the box "Remote to be registered" will be moved to the box "Registered remote".

(Registration is not complete at this point. The status of the remote will be shown as "Waiting for registration".)

(4) **Determination of information to be registered**

Click **Save the remote** to the base.

Then, click **Refresh all** to confirm that the setting has been reflected.

(When registration has been completed correctly, the status of the selected remote will change from "Waiting for registration" to "registered".)

(When the remote is registered correctly, the mode will change automatically.)

(5) **Change of operation mode** of the base

Change the pairing setting on the remote registration screen of the base to "Pairing disable" and reflect the change by clicking **Reset module** or by re-supplying power.

Now, the registration procedure for the base and the remote are complete.

When registering more than one remote is required, repeat procedures (3) and (4).

It is also possible to register more than one remote simultaneously to the base.



- Registration should be performed with power supplied to both base and remote.
- For the Input size and Output size of the remote, the setting of wireless registration will be reflected to the base. When changing the number of Input size and Output size of the remote, wireless registration should be performed again.
- The setting of the Input size and Output size of the base are valid all the time. Be careful that the I/O map will be different if the setting is changed after constructing the I/O map. After changing, the setting is reflected by pressing the [Reset] button or by supplying the power again.

•Dummy remote

The dummy remote can register a "Dummy area" in the I/O map. A remote can be added without changing the I/O map by registering the remote to the "Dummy area" even after system construction.

The remote allocation order to the I/O map is from smallest channel to largest channel registered by the wireless channel which has been set during remote registration.

At the time, the wireless channel in which no remote is registered will be ignored.

When adding new remote, it may be required to change the I/O map depending on the wireless channel number.

The dummy remote can be registered only with the base.

•Precautions

- For dummy remote registration, it is necessary to set the number of inputs/outputs.
If a remote with inputs/outputs which are different from the set numbers is registered, the I/O map should be changed.

•Dummy remote registration

- (1) **Change of operation mode** of the base
Change the pairing setting of the remote registration of the base to "Pairing enable" and reflect the change by clicking **Reset module** or by re-supplying power. Then, update the contents on the screen by clicking **Refresh all**.
- (2) **Inputs/outputs setting** of dummy remote
Set the number of inputs and outputs of the dummy remote.
- (3) **Allocation** of the dummy remote **to the required wireless channel**
Select the required wireless channel and click **Insert** so that the set dummy remote is displayed in the box "Registered remote".
(Dummy remote registration is not complete at this point. The status is "Waiting for registration".)
- (4) **Determination** of dummy remote **registration information**
Click **Save reg-info** to reflect the registered information.
(When registration has been completed correctly, the status of the dummy remote will change to "registered".)

Now, the registration procedure for the dummy remote are complete.

■ Dimensions

•EX600-WEN#

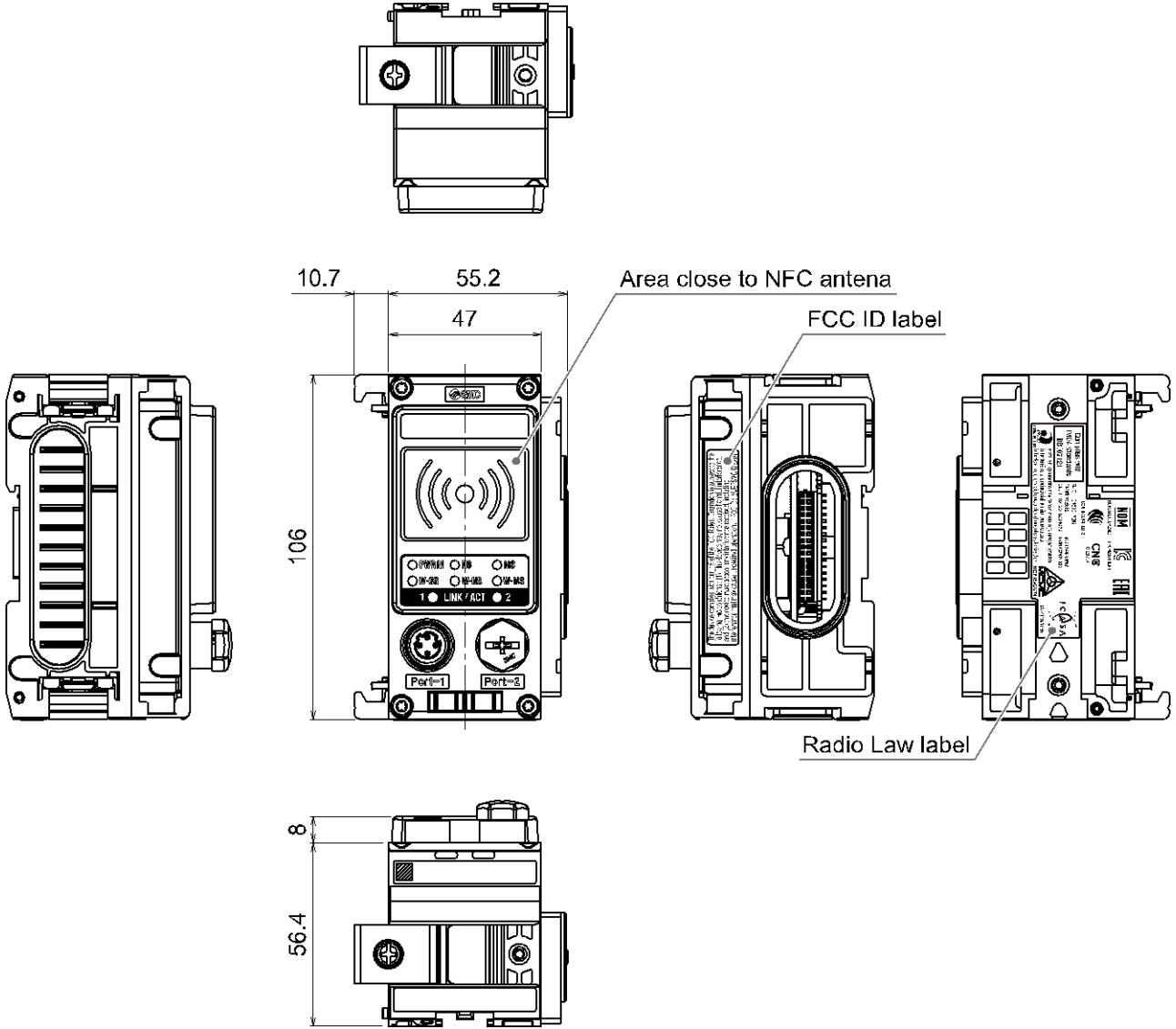

•EX600-WSV#

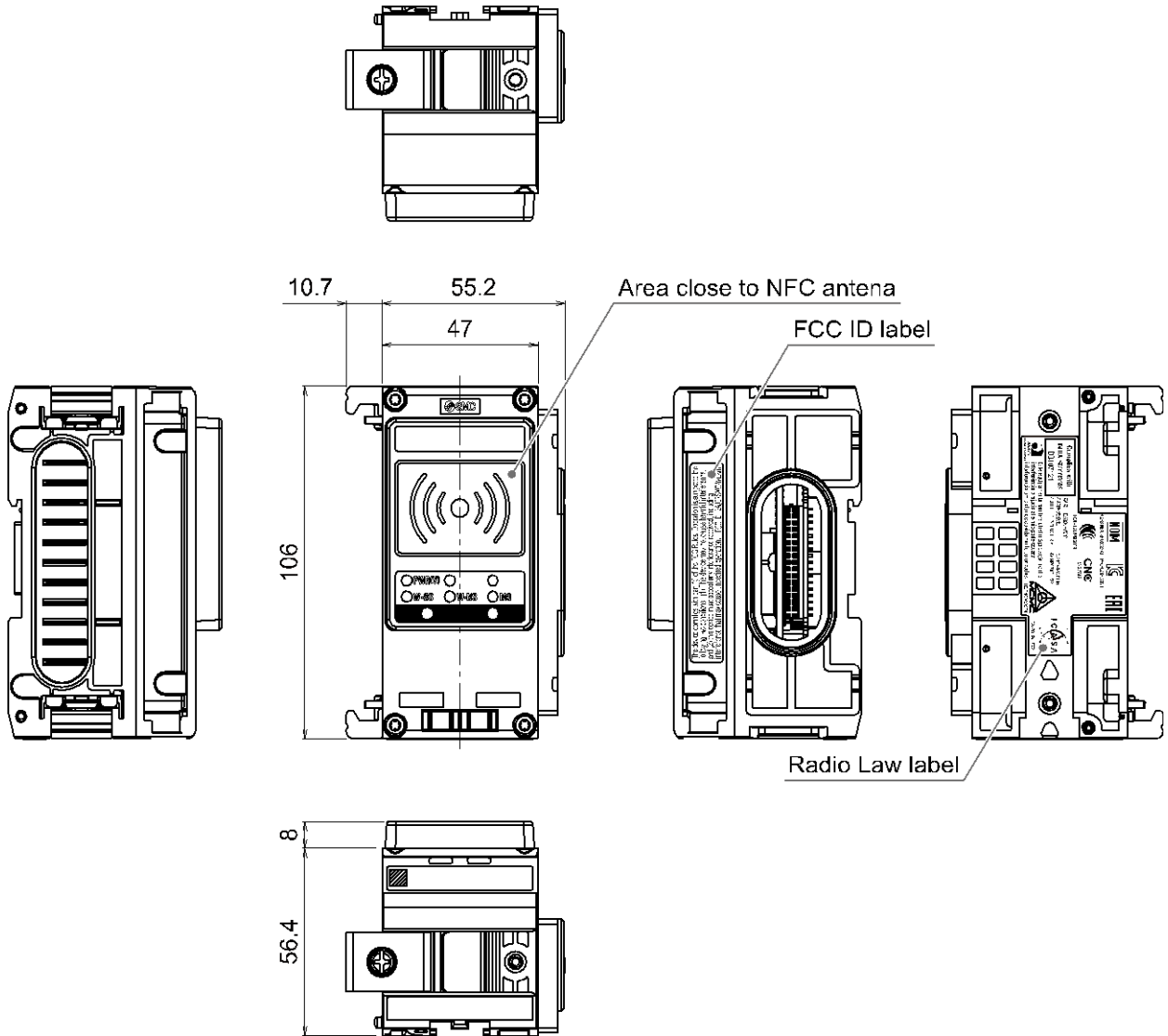

I/O Map

The table below shows the number of occupied bytes for each input/output unit of EX600 which can be connected to the base and remote.

The allocated input/output sizes can be changed depending on the occupied bytes of the diagnostic allocation and the EX600 I/O unit connected to the wireless unit.

Refer to the table below for the number of input/output bytes for each unit.

Unit name	Model	Unit product No.	I/O Occupation area	
			Input	Output
Wireless unit	WEN WSV	EX600-W### (32 points)	0 *1	4
		EX600-W### (24 points)	0 *1	3
		EX600-W### (16 points)	0 *1	2
		EX600-W### (8 points)	0 *1	1
		EX600-W### (0 point)	0 *1	0
Digital input unit	DX	EX600-DX#B (8 points)	1	0
		EX600-DX#C (8 points)	1	0
		EX600-DX#C1 (16 points)	2	0
		EX600-DX#D (16 points)	2	0
		EX600-DX#E (16 points)	2	0
		EX600-DX#F (16 points)	2	0
Digital output unit	DY	EX600-DY#B (8 points)	0	1
		EX600-DY#E (16 points)	0	2
		EX600-DY#F (16 points)	0	2
Digital I/O unit	DM	EX600-DM#E (8/8 points)	1	1
		EX600-DM#F (8/8 points)	1	1
Analogue input unit	AX	EX600-AXA*2 (2 points)	4	0
Analogue output unit	AY	EX600-AYA*2 (2 points)	0	4
Analogue I/O unit	AM	EX600-AMB*2 (2/2 points)	4	4

*1: The occupied bytes of input of the wireless unit (EX600-W###) will vary depending on the setting of the diagnostic allocation.
Refer to the section "Diagnostic allocation" for details.

*2: The minus ranges of the user setting are not supported.

■ I/O mapping

Please note the following points when configuring the I/O data size.

- The minimum data size for both input and output is 2 bytes.

When the total data size of the wireless system is 0 byte or 1 byte, the configuration size should be 2 bytes.

- If the data size of the actual input or output is an odd number, 1 byte (Padding data) will be added to the configuration size automatically so that it is adjusted to an even number.
- The remote allocation order to the I/O map is decided by the wireless channel at the remote registration. As they are allocated from the smallest registered channel number, the channel in which no remote is registered will be ignored (Refer to the figure below).

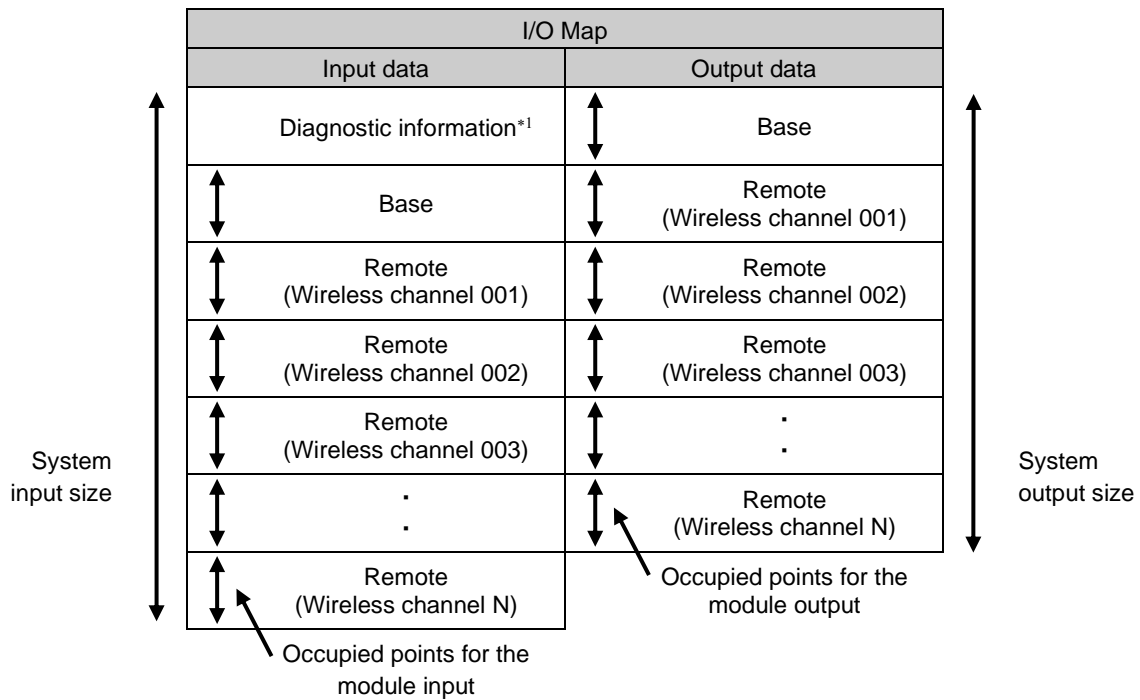

*1: This is selected according to the diagnostic allocation parameter setting of the base. Refer to the section "Diagnostic allocation" for details.

■ I/O mapping order of base/remote

Please note that the allocation order of the EX600 I/O unit and the valve manifold connected to the base or remote is different depending on the I/O unit layout mode in the wireless system parameter setting.

Mode 1: **Allocation from the end plate side to the right.**

Mode 2: **Allocation from the wireless unit side to the left.**

I/O mapping examples in Mode 1 and Mode 2 are shown below.

<Example 1>

● Mode 1

	Unit 0	Unit 1	Unit 2	
	DY#B	DX#D	EX600-WEN#	
End plate	Digital output	Digital input	Base	Valve manifold
	1-byte output	2-byte output	2-byte output	(16 points)

Base setting parameter

Diagnostic allocation: None/Simple/Detailed
 I/O mapping: Auto
 Input size: 32 points/4 bytes
 Output size: 32 points/4 bytes
 Valve manifold output size: 16 points/2 bytes
 I/O unit layout mode: Mode 1
 Number of remote connection: 15 pcs.

Base construction

Input data: [Unit 1] Digital input unit (EX600-DX#D): 2 bytes occupied
 Output data: [Unit 0] Digital output unit (EX600-DY#B): 1 byte occupied
 [Unit 2] Base (EX600-WEN#): 2 bytes occupied

	Unit 0	Unit 1	Unit 2	Unit 3	
	DY#B	AXA	DX#D	EX600-WSV#	
End plate	Digital output	Analogue input	Digital input	Remote	Valve manifold
	1-byte output	4-byte input	2-byte input	4-byte output	(32 points)

Remote setting parameter (Wireless channel 001)

Input size: 64 points/8 bytes
 Output size: 48 points/6 bytes
 Valve manifold output size: 32 points/4 bytes
 I/O unit layout mode: Mode 1

Remote construction (Wireless channel 001)

Input data: [Unit 1] Analogue input unit (EX600-AXA): 4 bytes occupied
 [Unit 2] Digital input unit (EX600-DX#D): 2 bytes occupied
 Output data: [Unit 0] Digital output unit (EX600-DY#B): 1 byte occupied
 [Unit 3] Remote (EX600-WSV#): 4 bytes occupied

	Unit 0	Unit 1	Unit 2	Unit 3	
	DY#B	DX#D	DX#B	EX600-WSV#	
End plate	Digital output	Digital input	Digital input	Remote	End plate
	1-byte output	2-byte input	1-byte input	0-byte output	(Output side)

Remote setting parameter (Wireless channel 002)

Input size: 32 points/4 bytes
 Output size: 16 points/2 bytes
 Valve manifold output size: 0 point/0 byte
 I/O unit layout mode: Mode 1

Remote construction (Wireless channel 002)

Input data: [Unit 1] Digital input unit (EX600-DX#D): 2 bytes occupied
 [Unit 2] Digital input unit (EX600-DX#B): 1 byte occupied
 Output data: [Unit 0] Digital output unit (EX600-DY#B): 1 byte occupied
 [Unit 3] Remote (EX600-WSV#): 0 byte occupied

•Diagnostic allocation: None

	Input data		Output data	
	Module name	Unit name	Module name	Unit name
byte 0	Base	DX#D (Unit 1)	Base	DX#B (Unit 0)
byte 1		Reserved		EX600-WEN# (Unit 2) Valve output: 16 points
byte 2				
byte 3				
byte 4	Remote (Wireless channel 001)	AXA (Unit 1)	Remote (Wireless channel 001)	
byte 5				EX600-WSV# (Unit 3) Valve output: 32 points
byte 6				
byte 7				
byte 8		DX#D (Unit 2)	Reserved	
byte 9				
byte 10		Reserved		Remote (Wireless channel 002)
byte 11	Reserved	Reserved	Reserved	
byte 12	Remote (Wireless channel 002)	DX#D (Unit 1)	/	
byte 13		DX#B (Unit 2)		
byte 14				
byte 15				
Total	16 byte		12 byte	

•Diagnostic allocation: Simple

	Input data		Output data		
	Module name	Unit name	Module name	Unit name	
byte 0	System diagnosis 1		Base	DY#B (Unit 0)	
byte 1	System diagnosis 2			EX600-WEN# (Unit 2) Valve output: 16 points	
byte 2	System diagnosis 3				
byte 3	System diagnosis 4				Reserved
byte 4	Base	DX#D (Unit 1)	Remote (Wireless channel 001)	DY#B (Unit 0)	
byte 5		Reserved		EX600-WSV# (Unit 3) Valve output: 32 points	
byte 6					
byte 7	Remote (Wireless channel 001)	AXA (Unit 1)			Remote (Wireless channel 002)
byte 8			DY#B (Unit 0)		
byte 9					
byte 10					
byte 11		DX#D (Unit 2)		Reserved	
byte 12					
byte 13					
byte 14	Remote (Wireless channel 002)	DX#D (Unit 1)	/		
byte 15					DX#B (Unit 2)
byte 16					
byte 17					
byte 18	Reserved	Reserved			
byte 19					
Total	20 byte		12 byte		

•Diagnostic allocation: Detailed

	Input data		Output data	
	Module name	Unit name	Module name	Unit name
byte 0	System diagnosis 1		Base	DY#*B (Unit 0)
byte 1	System diagnosis 2			EX600-WEN# (Unit 2) Valve output: 16 points
byte 2	System diagnosis 3			Reserved
byte 3	System diagnosis 4			
byte 4	Remote connection information (Wireless channel 1-7; bit 0 are fixed at "0".)		Remote (Wireless channel 001)	DY#B (Unit 0)
byte 5	Remote connection information (Wireless channel 8-15)			EX600-WSV# (Unit 3) Valve output: 32 points
byte 6	Remote diagnostic information *1 (Wireless channel 1-7)			
byte 7	Remote diagnostic information (Wireless channel 8-15)			
byte 8	Remote registration information (Wireless channel 1-7; bit 0 are fixed at "0".)			
byte 9	Remote registration information (Wireless channel 8-15)			
byte 10	Base	DX#D (Unit 1)	Remote (Wireless channel 002)	DY#B (Unit 0)
byte 11		Reserved		Reserved
byte 12		Reserved		
byte 13	Remote (Wireless channel 001)	AXA (Unit 1)	/	
byte 14				
byte 15				
byte 16		DX#D (Unit 2)		
byte 17		Reserved		
byte 18		Reserved		
byte 19	Remote (Wireless channel 002)	DX#D (Unit 1)		
byte 20		DX#B (Unit 2)		
byte 21		Reserved		
byte 22				
byte 23				
byte 24				
byte 25				
Total	26 byte		12 byte	

*: When the setting of diagnostic allocation is "Detailed", areas of the number of remote set at the Number of remote connection are occupied. (The occupied area also occupies the area for remote which has not been registered.)

*1: The remote diagnostic information bit 0 indicates the diagnostic information of the base.

<Example 2>

•Mode 2

	Unit 2	Unit 1	Unit 0	
	DY#B	DX#D	EX600-WEN#	
End plate	Digital output	Digital input	Base	Valve manifold
	1-byte output	2-byte input	2-byte output	(16 points)

Base setting parameter

Diagnostic allocation: None/Simple/Detailed
I/O mapping: Auto

Input size: 32 points/4 bytes

Output size: 32 points/4 bytes

Valve manifold output size: 16 points/2 bytes

I/O unit layout mode: Mode 2

Number of remote connection: 15 pcs.

Base construction

Input data: [Unit 1] Digital input unit (EX600-DX#D): 2 bytes occupied

Output data: [Unit 0] Base (EX600-WEN#): 2 bytes occupied

[Unit 2] Digital output unit (EX600-DY#B): 1 byte occupied

	Unit 3	Unit 2	Unit 1	Unit 0	
	DY#B	AXA	DX#D	EX600-WSV#	
End plate	Digital output	Analogue input	Digital input	Remote	Valve manifold
	1-byte output	4-byte input	2-byte input	4-byte output	(32 points)

Remote setting parameter (Wireless channel 001)

Input size: 64 points/8 bytes

Output size: 48 points/6 bytes

Valve manifold output size: 32 point/4 byte

I/O unit layout mode: Mode 2

Remote construction (Wireless channel 001)

Input data: [Unit 1] Digital input unit (EX600-DX#D): 2 bytes occupied

[Unit 2] Analogue input unit (EX600-AXA): 4 bytes occupied

Output data: [Unit 0] Remote (EX600-WSV#): 4 bytes occupied

[Unit 3] Digital output unit (EX600-DY#B): 1 byte occupied

	Unit 3	Unit 2	Unit 1	Unit 0	
	DY#B	DX#D	DX#B	EX600-WSV#	
End plate	Digital output	Digital input	Digital input	Remote	End plate
	1-byte output	2-byte input	1-byte input	0-byte output	(Output side)

Remote setting parameter (Wireless channel 002)

Input size: 32 points/4 bytes

Output size: 16 points/2 bytes

Valve manifold output size: 0 point/0 byte

I/O unit layout mode: Mode 2

Remote construction (Wireless channel 002)

Input data: [Unit 1] Digital input unit (EX600-DX#D): 2 bytes occupied

[Unit 2] Digital input unit (EX600-DX#B): 1 byte occupied

Output data: [Unit 0] Remote (EX600-WSV#): 0 bytes occupied

[Unit 3] Digital output unit (EX600-DY#B): 1 byte occupied

•Diagnostic allocation: None

	Input data		Output data			
	Module name	Unit name	Module name	Unit name		
byte 0	Base	DX#D (Unit 1)	Base	EX600-WEN# (Unit 0) Valve output: 16 points		
byte 1		Reserved		DY#B (Unit 2)		
byte 2		Reserved		Reserved		
byte 3						
byte 4	Remote (Wireless channel 001)	DX#D (Unit 1)	Remote (Wireless channel 001)	EX600-WSV# (Unit 0) Valve output: 32 points		
byte 5		AXA (Unit 2)		Remote (Wireless channel 002)	DY#B (Unit 3)	
byte 6					Reserved	Reserved
byte 7					Reserved	DY#B (Unit 3)
byte 8		Reserved		Reserved	Reserved	
byte 9						
byte 10						
byte 11						
byte 12	Remote (Wireless channel 002)	DX#B (Unit 1)	/			
byte 13		DX#D (Unit 2)				
byte 14		Reserved				
byte 15		Reserved				
Total	16 byte		12 byte			

•Diagnostic allocation: Simple

	Input data		Output data			
	Module name	Unit name	Module name	Unit name		
byte 0	System diagnosis 1		Base	EX600-WEN# (Unit 0) Valve output: 16 points		
byte 1	System diagnosis 2			DY#B (Unit 2)		
byte 2	System diagnosis 3			Reserved		
byte 3	System diagnosis 4					
byte 4	Base	DX#D (Unit 1)	Remote (Wireless channel 001)	EX600-WSV# (Unit 0) Valve output: 32 points		
byte 5		Reserved		DY#B (Unit 3)		
byte 6		Reserved		Reserved		
byte 7	Remote (Wireless channel 001)	AXA (Unit 2)		Remote (Wireless channel 002)	DY#B (Unit 3)	
byte 8					Reserved	Reserved
byte 9					Reserved	DY#B (Unit 3)
byte 10				Reserved	Reserved	
byte 11						
byte 12						
byte 13						
byte 14	Remote (Wireless channel 002)	DX#B (Unit 1)	/			
byte 15		DX#D (Unit 2)				
byte 16		Reserved				
byte 17		Reserved				
byte 18						
byte 19						
Total	20 byte		12 byte			

•Diagnostic allocation: Detailed

	Input data		Output data	
	Module name	Unit name	Module name	Unit name
byte 0	System diagnosis 1		Base	EX600-WEN# (Unit 0) Valve output: 16 points
byte 1	System diagnosis 2			
byte 2	System diagnosis 3			
byte 3	System diagnosis 4			
byte 4	Remote connection information (Wireless channel 1-7; bit 0 are fixed at "0".)		Remote (Wireless channel 001)	EX600-WSV# (Unit 0) Valve output: 32 points
byte 5	Remote connection information (Wireless channel 8-15)			
byte 6	Remote diagnostic information *1 (Wireless channel 1-7)			
byte 7	Remote diagnostic information (Wireless channel 8-15)			
byte 8	Remote registration information (Wireless channel 1-7; bit 0 are fixed at "0".)			
byte 9	Remote registration information (Wireless channel 8-15)			
byte 10	Base	DX#D (Unit 1)	Remote (Wireless channel 002)	DY#B (Unit 3)
byte 11		Reserved		Reserved
byte 12		Reserved		
byte 13	Remote (Wireless channel 001)	DX#D (Unit 1)	/	
byte 14		AXA (Unit 2)		
byte 15				
byte 16				
byte 17				
byte 18				
byte 19	Reserved			
byte 20	Reserved			
byte 21	Remote (Wireless channel 002)	DX#D (Unit 1)		
byte 22		DX#B (Unit 2)		
byte 23				
byte 24		Reserved		
byte 25				
Total	26 byte		12 byte	

*: When the setting of diagnostic allocation is "Detailed", areas of the number of remote set at the Number of remote connection are occupied. (The occupied area also occupies the area for remote which has not been registered.)

*1: The remote diagnostic information bit 0 indicates the diagnostic information of the base.

■ Diagnostic allocation

By setting the diagnostic allocation of the base, the following diagnostic data will be allocated to the head of the input data of the I/O map.

When the diagnostic allocation is set to "Detailed", the diagnostic size varies depending on the number of remote connections.

Diagnostic allocation	Diagnostic data		Diagnostic size
None	No diagnostic data		0 bytes
Simple	System diagnostics		4 bytes
Details	System diagnostics + Remote connection/ diagnostics/registration information	Number of remote connections: 0 pcs.	4 bytes
		Number of remote connections: 15 pcs.	10 bytes
		Number of remote connections: 31 pcs.	16 bytes
		Number of remote connections: 63 pcs.	28 bytes
		Number of remote connections: 127 pcs.	52 bytes

• Wireless system configuration

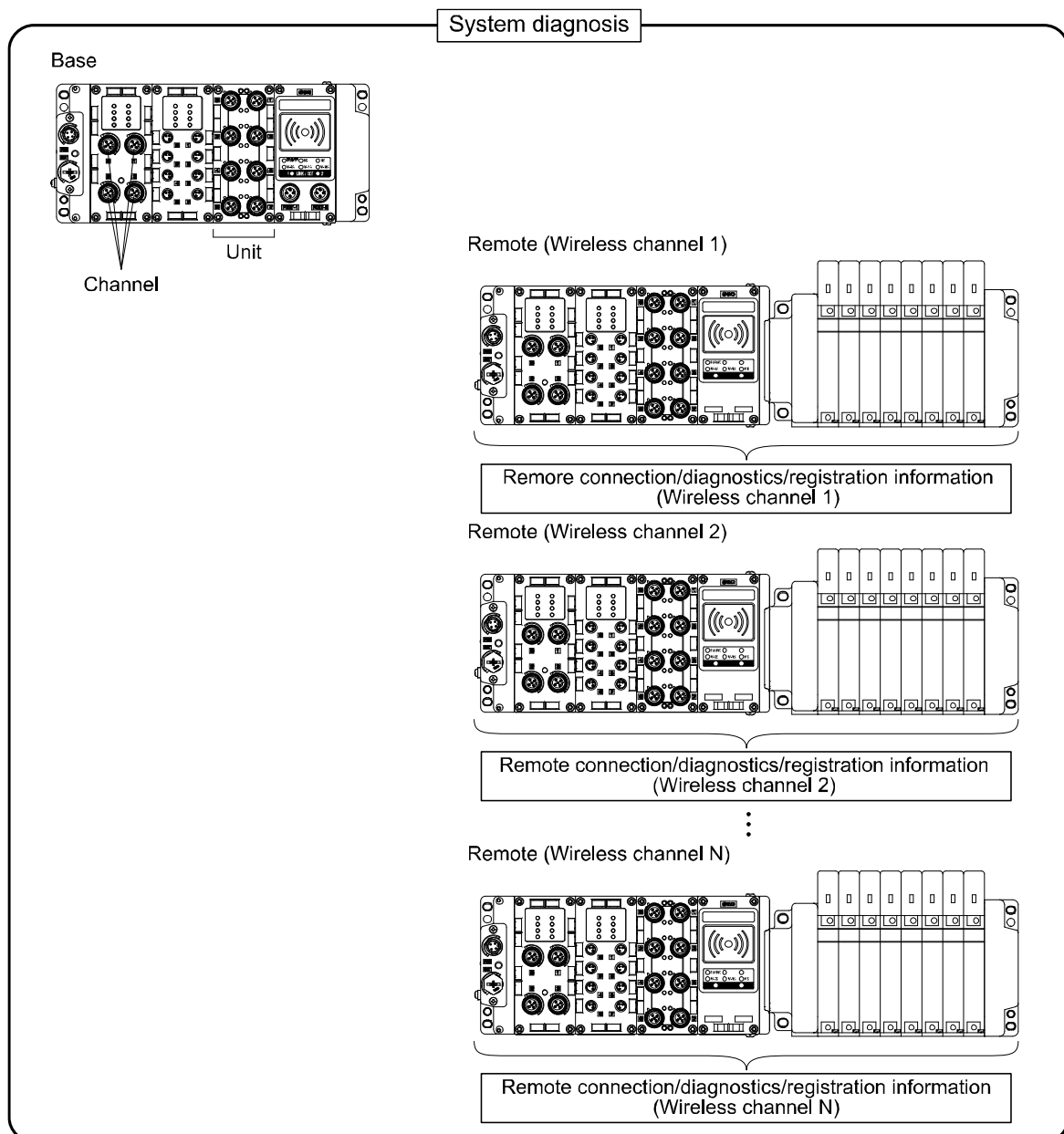

■ Detailed diagnostic data

When an error occurs in the wireless system (base or remote), a flag will be generated in a Bit corresponding to each diagnostic information.

The errors for the system diagnostics 1 to 4 are for the entire system. Therefore, even if there is only one unit which has an error in the constructed system, a flag will be generated in a Bit corresponding to the error content.

It is possible to check the classification of the remote which is generating an error using the remote diagnostic information.

(It is necessary to set the diagnostic allocation to "Detailed".)

Regardless of the setting of the diagnostic allocation, the module and unit which are generating errors can be specified using the SMC wireless system application.

Item	Byte	Bit No.	Content of diagnostics		Diagnosis area and condition when error occurs		How to reset	Reset conditions	Note (LED indications, etc.)
			Item	Details	Effective diagnosis area	I/O condition when diagnosis is conducted			
System diagnosis 1	0	0	User setting lower level detection	Detected that the analogue setting has exceeded the lower limit of the user set value.	Unit	Continue	Automatic reset	Select the range so that the analogue setting will be within the appropriate range of the user set value. Or disable the diagnostics.	Base MS: Red LED flashes or W-MS: Red LED flashes *1 Remote MS: Red LED flashes
		1	User setting upper limit detection	Detected that the analogue setting has exceeded the upper limit of the user set value.	Unit	Continue	Automatic reset	Select the range so that the analogue setting will be within the appropriate range of the user set value. Or disable the diagnostics.	
		2	Detection of the range lower limit	Detected that the analogue setting has exceeded the lower limit of the setting range.	Unit	Continue	Automatic reset	Select an appropriate range so that the input value is within the set range.	
		3	Detection of the range upper limit	Detected that the analogue setting has exceeded the upper limit of the setting range.	Unit	Continue	Automatic reset	Select an appropriate range so that the input value is within the set range.	
		4	Detection of upper limit of ON/OFF operation cycle	ON/OFF operating cycles has exceeded the upper limit of the setting value.	Unit	Continue	Automatic reset	Reset the ON/OFF cycles to zero. Or disable the diagnostics.	
		5	Detection of unconnected load	Detects the broken wire.	Unit	Continue	Manual/automatic reset	(1) Replace the valve or I/O device to check the operation. (2) Replace the valve or output device to check the operation.	

Item	Byte	Bit No.	Content of diagnostics		Diagnosis area and condition when error occurs		How to reset	Reset conditions	Note (LED indications, etc.)
			Item	Details	Effective diagnosis area	I/O condition when diagnosis is conducted			
System diagnostic 1	0	6	Short circuit detection of output load	A short-circuit of the valve or the output equipment has been detected.	Unit	Continue	Manual/ Auto	(1) Replace the valve or the input/output equipment, and check the operation. (2) Replace the valve or the output equipment, and check the operation.	Base MS: Red LED flashes or W-MS: Red LED flashes ^{*1} Remote MS: Red LED flashes
		7	Short circuit detection of power supply for control/input	A short-circuit of the input equipment power supply has been detected.	Unit	Continue	Auto	Check the part which has been generating the error and review the wiring or check if the input equipment is normal.	
System diagnostic 2	0	0	Detection of output (US2) power supply voltage drop	A voltage drop of the power supply voltage for output (US2) has been detected.	Unit	Continue	Auto	Supply 24 VDC±10% to the power supply voltage for output (US2).	Base PWR(V): Red LED flashes or W-MS: Red LED flashes Remote PWR(V): Red LED flashes
		1	Detection of control/input (US1) power supply voltage drop	A voltage drop of the power supply voltage for control/input (US1) has been detected.	Unit	Continue	Auto	Supply 24 VDC±10% to the power supply voltage for control/input (US1).	Base MS: Red LED flashes or W-MS: Red LED flashes Remote MS: Red LED flashes
	2	Reserved	-	-	-	-	-	-	-
	3	Connection failure between units (during operation)	An error has been generated in the communication between the wireless unit and EX600 I/O units.	Unit	Stop (HOLD)	Turn the power on again.	Confirm that there is no loose connection between the EX600 I/O units, and connect them correctly.	Base MS: Red LED flashes or W-MS: Red LED flashes Remote MS: Red LED flashes	

Item	Byte	Bit No.	Content of diagnostics		Diagnosis area and condition when error occurs		How to reset	Reset conditions	Note (LED indications, etc.)
			Item	Details	Effective diagnosis area	I/O condition when diagnosis is conducted			
System diagnostic 2	1	4	Connection failure between units (when power is supplied)	An error has been generated in the communication between the wireless unit and EX600 I/O units.	Unit	Stop (HOLD)	Turn the power on again.	Confirm that there is no loose connection between the EX600 I/O units, and connect them correctly.	Base MS: Red LED flashes or W-MS: Red LED flashes Remote MS: Red LED flashes
		5	Reserved	-		-	-	-	-
		6	Detection of system error (when power is supplied)	A non-restorable error has been generated in the system.	Unit	Stop (HOLD)	Manual	Supply power again. If the error is not restored, contact your SMC sales representative.	Base MS: Red LED is ON Remote MS: Red LED is ON
		7	Detection of hardware error (during operation)	A non-restorable error has been generated in the hardware.	Unit	Stop (HOLD)	Manual	Supply power again. If the error is not restored after resupplying power, contact your SMC sales representative.	Base MS: Red LED is ON or W-MS: Red LED is ON Remote MS: Red LED is ON
System diagnostic 3	2	0	Number of input/output points setting error	The number of occupied input/output points of the baser and remote has exceeded the set value.	System	Continue	Manual	Change the user's set value. Or, adjust the unit configuration so that the number of occupied points is within the set value.	Base MS: Red LED flashes or W-MS: Red LED flashes Remote MS: Red LED flashes
		1	Reserved	-	-	-	-	-	-
		2	Reserved	-	-	-	-	-	-
		3	Reserved	-	-	-	-	-	-
		4	Reserved	-	-	-	-	-	-
		5	Reserved	-	-	-	-	-	-
		6	Reserved	-	-	-	-	-	-
		7	Reserved	-	-	-	-	-	-

Item	Byte	Bit No.	Content of diagnostics		Diagnosis area and condition when error occurs		How to reset	Reset conditions	Note (LED indications, etc.)	
			Item	Details	Effective diagnosis area	I/O condition when diagnosis is conducted				
System diagnostic 4	3	0	Number of system input/output points setting error	The number of occupied system input/output points has exceeded the set value.	System	Continue	Manual	Change the user's set value. Or, adjust the unit configuration so that the number of occupied points is within the set value.	Base MS: Red LED flashes	
		1	Number of remote connections setting error (Outside of the wireless channel setting range)	Wireless channels other than those set at the remote connection have been registered.	System	Continue	Manual	Change the number of remote connection set value. Or, delete the registration of the remote (wireless channels) outside of the set range.	Base MS: Red LED flashes	
		2	Reserved	-	-	-	-	-	-	-
		3	Reserved	-	-	-	-	-	-	-
		4	Reserved	-	-	-	-	-	-	-
		5	Number of system input/output points has exceeded the upper limit	The number of occupied system input/output points has exceeded 1280/1280 points.	System	Stop (HOLD)	Manual	Adjust the unit configuration so that the number of system input/output points is within the controllable numbers.	Base MS: Red LED is ON or W-NS: Red LED is ON	
		6	Wireless registration data failed	An error has been generated in the wireless registration information.	System	Stop (HOLD)	Manual	Supply power again. If the error is not restored after resupplying power, contact your SMC sales representative.	Base MS: Red LED is ON or W-NS: Red LED is ON	
		7	Detection of wireless hardware error	A Non-restorable error has been generated in the hardware of the wireless units.	System	Stop (HOLD)	Manual	Supply power again. If the error is not restored after resupplying power, contact your SMC sales representative.	Base MS: Red LED is ON or W-NS: Red LED is ON	

Item	Byte	Bit No.	Content of diagnostics		Diagnosis area and condition when error occurs		How to reset	Reset conditions	Note (LED indications, etc.)
			Item	Details	Effective diagnosis area	I/O condition when diagnosis is conducted			
Remote connection information Wireless channel 1-7 (Bit 0 is fixed at "0".)	4	0	-	-	-	-	-	When the connection data is "0", the wireless communication with the remote is not connected. When the connection data is "1", the wireless communication with the remote is normal.	
		1	Connection condition of the remote communication (Wireless channel 1)	-	-	-	-		
		2	Connection condition of the remote communication (Wireless channel 2)	-	-	-	-		
		3	Connection condition of the remote communication (Wireless channel 3)	-	-	-	-		
		4	Connection condition of the remote communication (Wireless channel 4)	-	-	-	-		
		5	Connection condition of the remote communication (Wireless channel 5)	-	-	-	-		
		6	Connection condition of the remote communication (Wireless channel 6)	-	-	-	-		
		7	Connection condition of the remote communication (Wireless channel 7)	-	-	-	-		
Remote connection information Wireless channel 8-15	5	0	Connection condition of the remote communication (Wireless channel 8)	-	-	-	-		
		1	Connection condition of the remote communication (Wireless channel 9)	-	-	-	-		
		2	Connection condition of the remote communication (Wireless channel 10)	-	-	-	-		
		3	Connection condition of the remote communication (Wireless channel 11)	-	-	-	-		
		4	Connecting condition of the remote communication (Wireless channel 12)	-	-	-	-		
		5	Connection condition of the remote communication (Wireless channel 13)	-	-	-	-		
		6	Connection condition of the remote communication (Wireless channel 14)	-	-	-	-		
		7	Connection condition of the remote communication (Wireless channel 15)	-	-	-	-		

Item	Byte	Bit No.	Content of diagnostics		Diagnosis area and condition when error occurs		How to reset	Reset conditions	Note (LED indications, etc.)
			Item	Details	Effective diagnosis area	I/O condition when diagnosis is conducted			
Remote diagnostic information Wireless channel 1-7 (Bit 0 is for the base)	6	0	Presence/absence of system information error of base		-	-	-	-	No error in the base/remote when the diagnostic data is "0". An error has been generated in the base/remote when the diagnostic data is "1".
		1	Presence/absence of system information error of remote (Wireless channel 1)		-	-	-	-	
		2	Presence/absence of system information error of remote (Wireless channel 2)		-	-	-	-	
		3	Presence/absence of system information error of remote (Wireless channel 3)		-	-	-	-	
		4	Presence/absence of system information error of remote (Wireless channel 4)		-	-	-	-	
		5	Presence/absence of system information error of remote (Wireless channel 5)		-	-	-	-	
		6	Presence/absence of system information error of remote (Wireless channel 6)		-	-	-	-	
		7	Presence/absence of system information error of remote (Wireless channel 7)		-	-	-	-	
Remote diagnostic information (Wireless channel 8-15)	7	0	Presence/absence of system information error of remote (Wireless channel 8)		-	-	-	-	
		1	Presence/absence of system information error of remote (Wireless channel 9)		-	-	-	-	
		2	Presence/absence of system information error of remote (Wireless channel 10)		-	-	-	-	
		3	Presence/absence of system information error of remote (Wireless channel 11)		-	-	-	-	
		4	Presence/absence of system information error of remote (Wireless channel 12)		-	-	-	-	
		5	Presence/absence of system information error of remote (Wireless channel 13)		-	-	-	-	
		6	Presence/absence of system information error of remote (Wireless channel 14)		-	-	-	-	
		7	Presence/absence of system information error of remote (Wireless channel 15)		-	-	-	-	

Item	Byte	Bit No.	Content of diagnostics		Diagnosis area and condition when error occurs		How to reset	Reset conditions	Note (LED indications, etc.)
			Item	Details	Effective diagnosis area	I/O condition when diagnosis is conducted			
Remote registration information Wireless channel 1-7 (Bit 0 is fixed at "0".)	8	0	-		-	-	-	-	When the registration data is "0", no remote has been registered. When the registration data is "1", remote have been registered.
		1	Registration of remote (Wireless channel 1)		-	-	-	-	
		2	Registration of remote (Wireless channel 2)		-	-	-	-	
		3	Registration of remote (Wireless channel 3)		-	-	-	-	
		4	Registration of remote (Wireless channel 4)		-	-	-	-	
		5	Registration of remote (Wireless channel 5)		-	-	-	-	
		6	Registration of remote (Wireless channel 6)		-	-	-	-	
		7	Registration of remote (Wireless channel 7)		-	-	-	-	
Remote registration information (Wireless channel 8-15)	9	0	Registration of remote (Wireless channel 8)		-	-	-	-	
		1	Registration of remote (Wireless channel 9)		-	-	-	-	
		2	Registration of remote (Wireless channel 10)		-	-	-	-	
		3	Registration of remote (Wireless channel 11)		-	-	-	-	
		4	Registration of remote (Wireless channel 12)		-	-	-	-	
		5	Registration of remote (Wireless channel 13)		-	-	-	-	
		6	Registration of remote (Wireless channel 14)		-	-	-	-	
		7	Registration of remote (Wireless channel 15)		-	-	-	-	

*: The LED indicator W-MS on the base indicates the system status of the remote.

If it is ON or flashes, errors have been generated in the registered remote.

*: When the diagnostic data of the system diagnostics 1-4 is "0", no error is generated. When it is "1", errors have been generated.

*: This table is for 15 connected remote as set in the base setting.

The diagnostic size of the remote connection information, diagnostic information and registration information vary depending on the setting for the number of connected remote. Refer to the diagnostic size shown in the section "Diagnostic allocation" for details.

Specifications

•Base specifications

Models		EX600-WEN1	EX600-WEN2
Communication specifications	Communication protocol	EtherNet/IP™ (Conformance test version: Composit 12)	
	Transmission medium (cable)	Standard Ethernet cable (CAT5 or higher, 100BASE-TX)	
	Transmission speed	10 Mbps/100 Mbps	
	Transmission method	Full duplex/Half duplex	
	Configuration file	EDS file *1	
	IP address setting range	Manual/BOOTP, DHCP	
	Device information	Vender ID: 7 (SMC Corporation) Device Type: 12 (Communication adapter) Product Code: 186	
	Topology	Star, bus, ring (including DLR), line, tree	
	QuickConnect™ function	Applicable	
	DLR function	Applicable	
	Web server function	Applicable	
Wireless communication specifications	Protocol	SMC original protocol (SMC encryption)	
	Radio wave type (spread)	Frequency Hopping Spread Spectrum (FHSS)	
	Frequency	2.4 GHz (2403 to 2481 MHz)	
	Frequency channel	79 ch (Bandwidth: 1.0 MHz)	
	Communication speed	250 kbps	
	Communication distance	Within 10 m (depending on the operating environment)	
	Radio Law certificate	Refer to the official SMC website for the latest information as to which countries the product is certified.	
Electrical specifications	For control and input (US1)	Power supply voltage	24 VDC ±10%
		Current consumption	150 mA or less
	For output (US2)	Power supply voltage	24 VDC±10%
		Max. supply current	4 A

Models		EX600-WEN1	EX600-WEN2	
Input/Output specifications	Number of inputs	System input size	Max. 1280 points together with the registered remote	
		Input size	Max. 128 points (increase or decrease by 16 points)	
	Number of outputs	System output size	Max. 1280 points together with the registered remote	
		Output size	Max. 128 points (increase or decrease by 16 points)	
	Analogue input/output	AD refresh time	10 ms or less (the input connected to the base) 0.1/0.2/0.5/1/2/5/10/30/60 s (the input connected to the remote) *2	
		DA refresh time	10 ms or less (the output connected to the base) 0.1/0.2/0.5/1/2/5/10/30/60 s (the output connected to the remote) *2	
	Valve output	Output type	Source/PNP (-COM)	Sink/NPN (+COM)
		Number of outputs	Max. 32 points (0/8/16/24/32 points)	
		Connected load	Solenoid valve with surge voltage suppressor of 24 VDC and 1.5W or less (manufactured by SMC)	
	Number of remote connected		Max. 127 pcs. (0/15/31/63/127 pcs.)	
Number of connected EX600 I/O units		Max. nine EX600 I/O units (I/O = 128. I/O above 128 cannot be recognized)		
General specifications	Enclosure rating		Conforms to IP67 (with manifold assembled)	
	Ambient temperature (Operating temperature)		-10 to +50°C	
	Ambient temperature (storage temperature)		-20 to +60°C	
	Ambient humidity		35 to 85% RH (no condensation)	
	Withstand voltage		500 VAC-1 minute between external terminals and metallic parts	
	Insulation resistance		10 MΩ or more (500 VDC between external terminals and metallic parts)	
	Vibration resistance		Conforms to EN61131-2 5 ≤ f < 8.4 Hz 3.5 mm 8.4 ≤ f < 150 Hz 9.8 m/s ² (Excluding valve manifold)	
	Impact resistance		Conforms to EN61131-2 147 m/s ² , 11 ms (Excluding valve manifold)	
	Standard		CE/UKCA marked	
	Weight		300 g	
NFC communication specifications *3	Communication standard		ISO/IEC14430B (Type-B)	
	Frequency		13.56 MHz	
	Communication speed		20 to 100 kHz (I2C)	
	Communication distance		Up to 1 cm	

*1: The configuration file can be downloaded from the SMC website: <https://www.smcworld.com>

*2: Varies depending on the wireless communication status and the surrounding environment.

*3: The NFC communication RFID tag of the 13.56 MHz passive type.

*: “เครื่องโทรคมนาคมและอุปกรณ์นี้มีความสอดคล้องตามมาตรฐานหรือข้อกำหนดทางเทคนิคของ กสทช.”

(This telecommunication equipment conforms to the technical standards or requirements of NBTC.)

• 적합성 평가의 인증표시



인증 취득 상호	SMC 주식회사
기기 명칭	무선 데이터 통신 시스템용 무선기기 (무선 마스터 유닛)
제조년월	별도 표시
인증번호	R-C-OZK-WEN1
제조사/제조국가	SMC 주식회사/일본

A급 기기

(업무용 방송 통신 기자재)

본 기기는 업무용(A급) 전자파 적합기기이므로 판매자 또는 사용자는 이를 주의하여 주십시오.

가정 이외의 지역에서의 사용을 목적으로 합니다.

해당 무선 설비는 운용중 전파 혼신의 가능성이 있습니다.

인명 안전에 관련된 서비스는 할 수 없습니다.

•Remote specifications

Models			EX600-WSV1	EX600-WSV2	
Electrical specifications	For control and input (US1)	Power supply voltage	24 VDC \pm 10%		
		Current consumption	70 mA or less		
	For output (US2)	Power supply voltage	24 VDC \pm 10%		
		Max. supply current	4 A		
Input/output specifications	Number of inputs	Input size	Max. 128 points (increase or decrease by 16 points)		
	Number of outputs	Output size	Max. 128 points (increase or decrease by 16 points)		
	AD/DA refresh time		0.1/0.2/0.5/1/2/5/10/30/60 s *1		
	Number of connected EX600 I/O units		Max. Nine EX600 I/O units (I/O = 128, I/O above 128 cannot be recognized)		
	Valve output	Output type	Source/PNP (-COM)	Sink/NPN (+COM)	
		Number of outputs	Max. 32 points (0/8/16/24/32 points)		
Connected load		Solenoid valve with surge voltage suppressor of 24 VDC and 1.5 W or less (manufactured by SMC)			
Wireless communication specifications	Protocol		SMC original protocol (SMC encryption)		
	Radio wave type (spread)		Frequency Hopping Spread Spectrum (FHSS)		
	Frequency		2.4 GHz (2403 to 2481 MHz)		
	Frequency channel		79 ch (Bandwidth: 1.0 MHz)		
	Communication speed		250 kbps		
	Communication distance		Within 10 m (depending on the operating environment)		
	Radio Law certificate		Refer to the official SMC website for the latest information as to which countries the product is certified.		

Models		EX600-WSV1	EX600-WSV2
General specifications	Enclosure rating	Conforms to IP67 (with manifold assembled)	
	Ambient temperature (Operating temperature)	-10 to +50 °C	
	Ambient temperature (storage temperature)	-20 to +60 °C	
	Ambient humidity	35 to 85%RH (no condensation)	
	Withstand voltage	500 VAC-1 minute between external terminals and metallic parts	
	Insulation resistance	10 MΩ or more (500 VDC between external terminals and metallic parts)	
	Vibration resistance	Conforms to EN61131-2 5 ≤ f < 8.4 Hz 3.5 mm 8.4 ≤ f < 150 Hz 9.8 m/s ² (Excluding valve manifold)	
	Impact resistance	Conforms to EN61131-2 147 m/s ² , 11 ms (Excluding valve manifold)	
	Standard	CE/UKCA marked	
	Weight	280 g	
NFC communication specifications *2	Communication standard	ISO/IEC14430B (Type-B)	
	Frequency	13.56 MHz	
	Communication speed	20 to 100 kHz (I2C)	
	Communication distance	Up to 1 cm	

*1: Varies depending on the wireless communication status and the surrounding environment.

*2: The NFC communication RFID tag of the 13.56 MHz passive type.

*: “เครื่องมือโทรคมนาคมและอุปกรณ์นี้มีความสอดคล้องตามมาตรฐานหรือข้อกำหนดทางเทคนิคของ กสทช.”

(This telecommunication equipment conforms to the technical standards or requirements of NBTC.)

• 적합성 평가의 인증표시



인증 취득 상호	SMC 주식회사
기기 명칭	무선 데이터 통신 시스템용 무선기기 (무선 슬레이브 유닛)
제조년월	별도 표시
인증번호	R-C-OZK-WSV1
제조사/제조국가	SMC 주식회사/일본

A급 기기

(업무용 방송 통신 기자재)

본 기기는 업무용(A급) 전자파 적합기기이므로 판매자 또는 사용자는 이를 주의하여 주십시오.

가정 이외의 지역에서의 사용을 목적으로 합니다.

해당 무선 설비는 운용중 전파 혼신의 가능성이 있습니다.

인명 안전에 관련된 서비스는 할 수 없습니다.

Troubleshooting

When problems occur, take appropriate countermeasures while referring to the LED indication, troubleshooting and parameter settings.

If a cause applicable to the failure cannot be identified, this indicates that the equipment itself is broken. The fieldbus system damage can be caused by the operating environment. Contact SMC to obtain countermeasures.

•Troubleshooting list for base

LED	Description	Error indication	No.
-	All LEDs are OFF.	-	Refer to problem No. 1.
PWR (V)	PWR(V) LED does not turn on green.	Red LED flashes.	Refer to problem No. 2.
NS	NS LED does not turn on green.	Green LED flashes.	Refer to problem No. 3.
		Red LED flashes.	
		Red LED is ON.	
		OFF	
MS	MS LED does not turn on green.	Green LED flashes.	Refer to problem No. 4.
		Red LED flashes.	
		Red LED is ON.	
		OFF	
W-SS	Red W-SS LED flashes or is OFF.	Red LED flashes.	Refer to problem No. 5.
		OFF	
W-NS	W-NS LED does not turn on green.	Green LED flashes.	Refer to problem No. 6.
		Red LED flashes.	
		Red LED is ON.	
		Orange LED is ON.	
		Red and green LEDs are ON alternately.	
		OFF	
W-MS	W-MS LED does not turn on green.	Red LED flashes.	Refer to problem No. 7.
		Red LED is ON.	
		OFF	
LINK/ACT	LINK/ACT1 and 2 LED are ON or OFF.	ON	Refer to problem No. 8.
		OFF	
The valve does not operate correctly.			Refer to problem No. 9.
Digital input/output device does not operate correctly.			Refer to problem No. 10.
Analogue input/output device does not operate correctly			Refer to problem No. 11.
Problems related to NFC.			Refer to problem No. 12.

•Troubleshooting for base

Problem No.	Error indication	Possible cause	Investigation and countermeasures
1	All LEDs are OFF.	Power supply for control and input (US1) has not been supplied.	Supply a voltage of 24 VDC \pm 10% to the power supply for control and input (US1).
2	PWR(V): Red LED flashes.	Output power supply voltage (US2) is low.	The power supply voltage for output (US2) has dropped. Check that a voltage of 24 VDC \pm 10% is applied.
	PWR(V): LED is OFF.	Power supply for control and input (US1) has not been supplied.	Supply a voltage of 24 VDC \pm 10% to the power supply for control and input (US1).
3	NS: Green LED flashes.	EtherNet/IP™ communication has not been established.	Check the following and restart. <ul style="list-style-type: none"> •Signal line from PLC is connected correctly. •The communication speed of the PLC and base is appropriate. •Wire the communication line away from noise sources.
	NS: Red LED flashes.	EtherNet/IP™ communication time out.	Check the following and restart. <ul style="list-style-type: none"> •Signal line from PLC is connected correctly. •The communication speed of the PLC and base is appropriate. •Wire the communication line away from noise sources.
	NS: Red LED is ON.	IP address has been duplicated.	The set IP address has been used for other equipment. Set an IP address which has not been used.
	NS: LED is OFF.	IP address not set.	Set the IP address correctly.

Problem No.	Error indication	Possible cause	Investigation and countermeasures
4	MS: Green LED flashes.	(1) Abnormal configuration. (2) The PLC is in idling state.	(1) Set up the configuration correctly. (2) Set the PLC to RUN status.
	MS: Red LED flashes.	The following diagnostic information is detected. (1) Low power supply voltage for control and input (US1). (2) Excessive I/O setting inputs/outputs. (3) Abnormal number of remote connection (4) Error in communication between units. (4)-1 Abnormal digital input unit. (4)-2 Abnormal digital output unit. (4)-3 Abnormal digital input/output unit. (5) EX600 I/O unit detects diagnostic information. (5)-1 Short-circuited power supply voltage for control and input (US1). (5)-2 Short-circuited power supply voltage for output (US2). (5)-3 Short-circuited output load (5)-4 Analogue I/O upper and lower set limit exceeded (5)-5 Analogue Input range upper and lower limit exceeded (5)-6 ON/OFF operations has exceeded the set value (6) Valve diagnostic information detected. (6)-1 Valve short-circuited. (6)-2 Broken valve wire	After checking the error contents referring to the system diagnostic information and LED indication, refer to the following countermeasures. (1) The power supply voltage for control and input (US1) has dropped. Check that a voltage of 24 VDC±10% is applied. (2)-1 The number of system input/output points has exceeded the set value. Check the total number of input/output points allocated to the wireless system (base and remote). (2)-2 The input and output sizes have exceeded the set value. Check the occupied bytes of the EX600 I/O unit and valve manifold connected to the wireless base. (3) Change the set number of remote connections. Delete the registration of the remote (wireless channels) outside of the set range or change the channel setting. (4) Confirm that there is no loose connection between the units and connect them correctly. (5) Check the part where the error occurs by checking the LED indication and information of the system diagnostics, and refer to the operation manual for the digital and analogue unit. 6) Replace the valve and check the operation.
	MS: Red LED is ON.	(1) Number of system input/output points has exceeded the upper limit. (2) Base broken	(1) Check the number of input/output points allocated to the wireless system (base and remote) is more than 1280 points. Adjust the number of input/output points so that it is not more than 1280 points. (2) Replace the base. If the error is not restored after replacement, stop using the equipment and contact your SMC sales representative.
	MS : LED is OFF.	Base power OFF.	Check that the power supply voltage for control and input (US1) is supplied to the base.

Problem No.	Error indication	Possible cause	Investigation and countermeasures
5	W-SS: Red LED flashes.	(1) Power has not been supplied to the remote. (2) Low signal power on wireless communication.	(1) Check that the power supply voltage for control and input (US1) is supplied to the remote. (2) The distance which wireless communication between wireless systems can be established may have been exceeded. Reconsider the operating environment, such as the installation conditions, of the base and remote.
	W-SS: LED is OFF.	Remote has not been registered.	Check the registration status of the remote and conduct pairing correctly.
6	W-NS: Green LED flashes.	(1) Power to the remote is OFF. (2) Low signal power on wireless communication.	(1) Check that the power supply voltage for control and input (US1) is supplied to the remote. (2) The distance which wireless communication between wireless systems can be established may have been exceeded. Reconsider the operating environment, such as the installation conditions, of the base and remote.
	W-NS: Red LED flashes.	(1) Power to the remote is OFF. (2) Low signal power on wireless communication.	(1) Check that the power supply voltage for control and input (US1) is supplied to the remote. (2) The distance which wireless communication between wireless systems can be established may have been exceeded. Reconsider the operating environment, such as the installation conditions, of the base and remote.
	W-NS: Red LED is ON.	No remote are connected.	Replace the base. If the error is not restored after replacement, stop using the equipment and contact your SMC sales representative.
	W-NS: Orange LED is ON.	Forced output.	The base has been set to Forced output mode. Change the mode according to the application.
	W-NS: Red/green	Wireless communication connection is in paring mode.	The system has been set to "Paring enable". Change the setting to "Paring disable" when pairing is not conducted.
	W-NS: LED is OFF.	Remote has not been registered.	Check the registration status of the wireless unit and conduct pairing correctly.

Problem No.	Error indication	Possible cause	Investigation and countermeasures
7	W-MS: Red LED flashes.	<p>The following diagnostic information is detected.</p> <p>(1) Low power supply voltage for control and input (US1).</p> <p>(2) Low power supply voltage level for output (US2).</p> <p>(3) Excessive I/O setting for inputs/outputs.</p> <p>(4) Error in communication between units. (4)-1 Abnormal digital input unit. (4)-2 Abnormal digital output unit. (4)-3 Abnormal digital input/output unit.</p> <p>(5) EX600 I/O unit detects diagnostic information. (5)-1 Short-circuited power supply voltage for control and input (US1). (5)-2 Short-circuited power supply voltage for output (US2). (5)-3 Short-circuited output load. (5)-4 Analogue I/O upper and lower set limit exceeded (5)-5 Analogue Input range upper and lower limit exceeded</p> <p>(6) Valve diagnostic information detected. (6)-1 Valve short-circuited. (6)-2 Broken valve wire</p>	<p>After checking the error contents while referring to the system diagnostic information and LED indication, refer to the following countermeasures.</p> <p>As this LED indicates the system status of the remote, the following diagnoses can be conducted only when the diagnostic allocation is set to "Detailed".</p> <p>(1) The power supply voltage for control and input (US1) has dropped. Check that a voltage of 24 VDC±10% is supplied.</p> <p>(2) The power supply voltage for output (US2) has dropped. Check that a voltage of 24 VDC±10% is supplied.</p> <p>(3) The input and output sizes have exceeded the set value. Check the occupied bytes of the EX600 I/O unit and valve manifold connected to the remote.</p> <p>(4) Confirm that there is no loose connection between the units and connect them correctly.</p> <p>(5) Check the part where the error occurs by checking the LED indication and information of the system diagnosis, and refer to the operation manual for the digital and analogue unit.</p> <p>(6) Replace the valve, and check the operation.</p>
	W-MS: Red LED is ON.	Remote broken.	<p>Replace the remote.</p> <p>If the error is not restored after replacement, stop using the equipment and contact your SMC sales representative.</p>
	W-MS: LED is OFF.	<p>(1) Remote has not been registered.</p> <p>(2) Power has not been supplied to the remote.</p>	<p>(1) Check the registration status of the remote and conduct pairing correctly.</p> <p>(2) Check that the power supply voltage for control and input (US1) is supplied to the remote.</p>

Problem No.	Error indication	Possible cause	Investigation and countermeasures
8	LINK/ACT: LED is ON. (PORT-1, -2)	LINK is established, but no data has been received.	Check the following items and restart. (1) Check the PLC condition and run the PLC. (2) Check for looseness and broken lines of the connector. (3) Keep noise sources away from the communication cable.
	LINK/ACT: LED is OFF. (PORT-1, -2)	LINK has not been established.	Check the following items and restart. (1) Check that power is supplied to the EtherNet/IP™ device one level above. (2) Check for looseness and broken lines of the connector of the LINK/ACT PORT 1/PORT 2 communication cables. (3) Keep noise sources away from the communication cable.
9	Abnormal valve operation.	Abnormal program.	Check if the program such as PLC ladder logic program works correctly.
		Output power supply voltage (US2) is low.	Check that the green PWR(V) LED of the base is ON. If it is OFF or a red LED flashes, supply a voltage of 24 VDC±10% to the power supply for output (US2).
		Connection failure between the base and valve manifold.	Confirm that the connector between the base and valve manifold has not been damaged, such as bent pins, and connect them correctly.
		Mismatched output type.	If the polarity of the valve does not match with the base, replace one of them to make the combination match. •EX600-WEN1 (PNP output) ⇒ Negative common type valve (-COM) •EX600-WEN2 (NPN output) ⇒ Positive common type valve (+COM)
		Base broken.	Replace the base and check the operation.
		Valve failure.	Replace the valve, and check the operation. Or refer to Troubleshooting for the valve.

Problem No.	Error indication	Possible cause	Investigation and countermeasures
10	Abnormal digital input device operation.	Mismatched input type.	If the polarities (PNP, NPN) of the digital input unit do not match with those of digital input equipment, replace one of them to make the combination match.
		Low power supply voltage for control and input (US1).	Check that the power supply voltage for control and input (US1) of 24 VDC±10% is supplied to the base.
		Wiring or connection failure.	Connect the wiring between the digital input unit and the digital input equipment correctly.
		Digital input unit broken.	Replace the digital input unit, and check the operation.
		Digital input equipment broken.	Replace the digital input equipment, and check the operation. Or, refer to Troubleshooting for the applicable digital input equipment.
	Abnormal digital output equipment operation.	Mismatched output type.	If the polarities (PNP, NPN) of the digital output unit do not match with those of digital output equipment, replace one of them to make the combination match.
		Output power supply voltage (US2) is low.	Check that the green PWR(V) LED of the base is ON. If it is OFF or a red LED flashes, supply a voltage of 24 VDC±10% to the power supply for output (US2).
		Wiring or connection failure.	Connect the wiring between the digital output unit and the digital output equipment correctly.
		Digital output unit broken.	Replace the digital output unit, and check the operation.
		Digital output equipment broken.	Replace the digital output equipment, and check the operation. Or, refer to Troubleshooting for the applicable digital output equipment.
		Abnormal program.	Check that the program such as PLC ladder logic program operates correctly.

Problem No.	Error indication	Possible cause	Investigation and countermeasures
11	Abnormal operation of the analogue input equipment	Abnormal power supply for control and input (US1)	Check that the power supply voltage for control and input (US1) supplied to the base is 24 VDC $\pm 10\%$.
		Analogue input signal range setting failure	Check the analogue input equipment specification, and set the input signal range according to the specification.
		Analogue data format does not match.	Check that the data format setting of the analogue input unit is correct.
		Wiring or connection is defective.	Connect the wiring between the digital input unit and the digital input equipment correctly.
		Analogue input unit faulty	Replace the analogue input unit, and check the operation.
		Analogue input equipment faulty	Replace the analogue input equipment, and check the operation. Or, refer to Troubleshooting for the applicable analogue input equipment.
	Abnormal operation of the analogue output equipment	Abnormal power supply for output (US2)	Check that the green PWR(V) LED of the base is ON. If it is OFF or a red LED flashes, supply a voltage of 24 VDC $\pm 10\%$ to the power supply for output (US2).
		Analogue output signal range setting failure	Check the analogue output equipment specification, and set the output signal range according to the specification.
		Analogue data format does not match.	Check that the data format setting of the analogue output unit is correct.
		Wiring or connection is defective.	Connect the wiring between the analogue output unit and the analogue output equipment correctly.
		Analogue output unit faulty	Replace the analogue output unit, and check the operation.
		Analogue output equipment faulty	Replace the analogue output equipment, and check the operation. Or, refer to Troubleshooting for the applicable analogue output equipment.
		Abnormal program, etc.	Check that the ladder logic program works correctly.

Problem No.	Error indication	Possible cause	Investigation and countermeasures
12	NFC communication error	NFC communication is not established (communication failure).	<p>Check the following items and check the operation again.</p> <ul style="list-style-type: none"> •Check if the specifications of the NFC reader/writer to be used are appropriate. •Confirm that the settings of the NFC port and PaSoRi of the PC are correct. •Confirm that the NFC reader/writer are connected correctly. •The communication distance is outside of the NFC range. Place the body (area close to NFC antenna) close to the NFC reader/writer.
		NFC reader/writer broken.	Replace the NFC reader/writer and check the operation. If the error is not restored after replacement, stop using the equipment and contact your SMC sales representative.

•Troubleshooting list for remote

LED	Details	Error indication	No.
-	All LEDs are OFF.	-	Refer to problem No. 1.
PWR (V)	PWR(V) LED does not turn on green.	Red LED flashes.	Refer to problem No. 2.
MS	MS LED does not turn on green.	Red LED flashes.	Refer to problem No. 3.
		Red LED is ON	
		OFF	
W-SS	Red W-SS LED flashes or is OFF.	Red LED flashes.	Refer to problem No. 4.
		OFF	
W-NS	W-NS LED does not turn on green.	Green LED flashes.	Refer to problem No. 5.
		Red LED flashes.	
		Red LED is ON.	
		Orange LED is ON.	
		Red and green LEDs are ON alternately.	
		OFF	
The valve does not operate correctly.			Refer to problem No. 6.
Digital input/output device does not operate correctly.			Refer to problem No. 7.
Analog input/output device does not operate correctly.			Refer to problem No. 8.
Problems related to the NFC.			Refer to problem No. 9.

•Troubleshooting for remote

Problem No.	Error indication	Possible cause	Investigation and countermeasures
1	All LEDs are OFF.	Power supply for control and input (US1) is OFF.	Supply a voltage of 24 VDC±10% to the power supply for control and input (US1).
2	PWR(V): Red LED flashes.	Output power supply voltage (US2) is low.	The power supply voltage for output (US2) has dropped. Check that a voltage of 24 VDC±10% is supplied.
	PWR(V): LED is OFF.	Power supply for control and input (US1) is OFF.	Supply a voltage of 24 VDC±10% to the power supply for control and input (US1).
3	MS: Red LED flashes.	The following diagnostic information is detected.	After checking the error contents while referring to the system diagnostic information and LED indication, refer to the following countermeasures.
		(1) Low power supply voltage level for control and input (US1). (2) Excessive I/O setting inputs/outputs. (3) Error in communication between units. (3)-1 Abnormal digital input unit. (3)-2 Abnormal digital output unit. (3)-3 Abnormal digital input/output unit. (4) EX600 I/O unit detects diagnostic information (4)-1 Short-circuited power supply voltage for control and input (US1). (4)-2 Short-circuited power supply voltage for output (US2). (4)-3 Short-circuited output load. (4)-4 Analogue I/O upper and lower set limit exceeded (4)-5 Analogue Input range upper and lower limit exceeded (5) Valve diagnostic information detected. (5)-1 Valve short-circuited. (5)-2 Broken valve wire	(1) The power supply voltage for control and input (US1) has dropped. Check the voltage of 24 VDC±10% is supplied. (2) The input and output sizes have exceeded the set value. Check the occupied bytes of the EX600 I/O unit and valve manifold connected to the remote. (3) Confirm that there is no loose connection between the units and connect them correctly. (4) Check the part where the error occurs by checking the LED indication and the system diagnostic information, and refer to the operation manual for the digital and analogue unit. (5) Replace the valve, and check the operation.
	MS: Red LED is ON.	Remote broken	Replace the remote. If the error is not restored after replacement, stop using the equipment and contact your SMC sales representative.
	MS: LED is OFF.	(1) Remote has not been registered. (2) Power to the remote is OFF.	(1) Check the registration status of the remote and conduct pairing correctly. (2) Check that the power supply voltage for control and input (US1) is supplied to the remote.

Problem No.	Error indication	Possible cause	Investigation and countermeasures
4	W-SS: Red LED flashes.	(1) Power to the remote is OFF. (2) Low signal power on wireless communication.	(1) Check that the power supply voltage for control and input (US1) is supplied to the remote. (2) The distance which wireless communication between wireless systems can be established may have been exceeded. Reconsider the operating environment, such as the installation conditions, of the base and remote.
	W-SS: LED is OFF.	Remote unit has not been registered.	Check the registration status of the remote and conduct pairing correctly.
5	W-NS: Red LED flashes.	(1) Power to the base is OFF. (2) Low signal power on wireless communication.	(1) Check that the power supply voltage for control and input (US1) is supplied to the base. (2) The distance which wireless communication between wireless systems can be established may have been exceeded. Reconsider the operating environment, such as the installation conditions, of the base and remote.
	W-NS: Red LED is ON.	No remote are connected.	Replace the remote. If the error is not restored after replacement, stop using the equipment and contact your SMC sales representative.
	W-NS: Orange LED is ON.	Forced output	The base has been set to Forced output mode. Change the mode according to the application.
	W-NS: Red/green LED	Wireless communication connection is in pairing mode.	The system has been set to "Pairing enable". Change the setting to "Pairing disable" when pairing is not conducted.
	W-NS: LED is OFF.	Remote has not been registered.	Check the registration status of the wireless unit and conduct pairing with the remote correctly.

Problem No.	Error indication	Possible cause	Investigation and countermeasures
6	Abnormal valve operation	Abnormal program	Check that the program such as the PLC ladder logic program operates correctly.
		Output power supply voltage (US2) is low.	Check that the green PWR(V) LED of the base is ON. If it is OFF or a red LED flashes, supply a voltage of 24 VDC±10% to the power supply for output (US2).
		Connection failure between the base and valve manifold.	Confirm that the connector between the base and manifold valve has not been damaged, such as bent pins, and connect them correctly.
		Mismatched output type	If the polarity of the valve does not match with the base, replace one of them to make the combination match. •EX600-WSV1 (PNP output) ⇒ Negative common type valve (-COM) •EX600-WSV2 (NPN output) ⇒ Positive common type valve (+COM)
		Base broken	Replace the base and check the operation.
		Valve failure	Replace the valve, and check the operation. Or, refer to Troubleshooting for the valve.

Problem No.	Error indication	Possible cause	Investigation and countermeasures
7	Abnormal digital input device operation	Input type does not match.	If the polarities (PNP, NPN) of the digital input unit do not match with those of digital input equipment, replace one of them to make the combination match.
		Low power supply voltage for control and input (US1)	Check that the power supply voltage for control and input (US1) of 24 VDC±10% is supplied to the base.
		Wiring or connection is defective.	Connect the wiring between the digital input unit and the digital input equipment correctly.
		Digital input unit broken	Replace the digital input unit, and check the operation.
		Digital input equipment broken	Replace the digital input equipment, and check the operation. Or, refer to Troubleshooting for the applicable digital input equipment.
	Abnormal digital output equipment operation	Mismatched output type	If the polarities (PNP, NPN) of the digital output unit do not match with those of digital output equipment, replace one of them to make the combination match.
		Output power supply voltage (US2) is low.	Check that the green PWR(V) LED of the base is ON. If it is OFF or a red LED flashes, supply a voltage of 24 VDC±10% to the power supply for output (US2).
		Wiring or connection is defective.	Connect the wiring between the digital output unit and the digital output equipment correctly.
		Digital output unit broken	Replace the digital output unit, and check the operation.
		Digital output equipment broken	Replace the digital output equipment, and check the operation. Or, refer to Troubleshooting for the applicable digital output equipment.
		Abnormal program	Check that the program such as the PLC ladder logic program operates correctly.

Problem No.	Error indication	Possible cause	Investigation and countermeasures
8	Abnormal operation of the analogue input equipment	Abnormal power supply for control and input (US1)	Check that the power supply voltage for control and input (US1) supplied to the base is 24 VDC $\pm 10\%$.
		Analogue input signal range setting failure	Check the analogue input equipment specification, and set the input signal range according to the specification.
		Analogue data format does not match.	Check that the data format setting of the analogue input unit is correct.
		Wiring or connection is defective.	Connect the wiring between the digital input unit and the digital input equipment correctly.
		Analogue input unit faulty	Replace the analog input unit, and check the operation.
		Analogue input equipment faulty	Replace the analogue input equipment, and check the operation. Or, refer to Troubleshooting for the applicable analogue input equipment.
	Abnormal operation of the analogue output equipment	Abnormal power supply for output (US2)	Check that the green PWR(V) LED of the base is ON. If it is OFF or a red LED flashes, supply a voltage of 24 VDC $\pm 10\%$ to the power supply for output (US2).
		Analogue output signal range setting failure	Check the analogue output equipment specification, and set the output signal range according to the specification.
		Analogue data format does not match.	Check that the data format setting of the analogue output unit is correct.
		Wiring or connection is defective.	Connect the wiring between the analogue output unit and the analogue output equipment correctly.
		Analogue output unit faulty	Replace the analogue output unit, and check the operation.
		Analogue output equipment faulty	Replace the analogue output equipment, and check the operation. Or, refer to Troubleshooting for the applicable analogue output equipment.
		Abnormal program, etc.	Check that the ladder logic program works correctly.

Problem No.	Error indication	Possible cause	Investigation and countermeasures
9	NFC communication error	NFC communication is not established (communication failure)	<p>Check the following items and check the operation again.</p> <ul style="list-style-type: none"> •Check if the specifications of the NFC reader/writer to be used are appropriate. •Confirm that the settings of the NFC port and PaSoRi of the PC are correct. •Confirm that the NFC reader/writer are connected correctly. •The communication distance is outside of the NFC range. Place the body (area close to NFC antenna) close to the NFC reader/writer.
		NFC reader/writer broken	<p>Replace the NFC reader/writer and check the operation. If the error is not restored after replacement, stop using the equipment and contact your SMC sales representative.</p>

End plate

Model Indication and How to Order

EX600-ED □ - □

End plate at D side

Mounting method

Connector

Symbol	Connector	Key type	Function
2	M12 (5-pin)	B-coded	IN
3	7/8 inch (5-pin)	-	IN
4	M12 (4-pin/5-pin)	A-coded	IN/OUT (PIN layout 1*)
5	M12 (4-pin/5-pin)	A-coded	IN/OUT (PIN layout 2)

Symbol	Description
Nil	No DIN rail bracket
2	With DIN rail bracket (VQC/SV/S0700 valve)
3	With DIN rail bracket (SY/JSY valve)

*: Refer to Connector Pin No. (page 90) for details of the PIN layout 1 and 2.

EX600-EU1 - □

End plate at U side

Mounting method

Symbol	Description
Nil	No DIN rail bracket
2	With DIN rail bracket (EX600-ED#-2)
3	With DIN rail bracket (EX600-ED#-3)

Summary of Product parts

•EX600-ED2-#

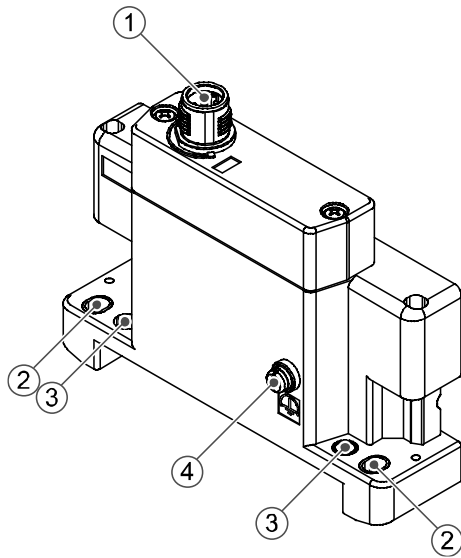

•EX600-ED3-#

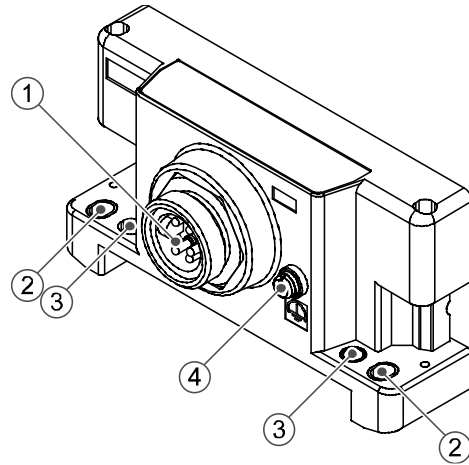

•EX600-EU1-#

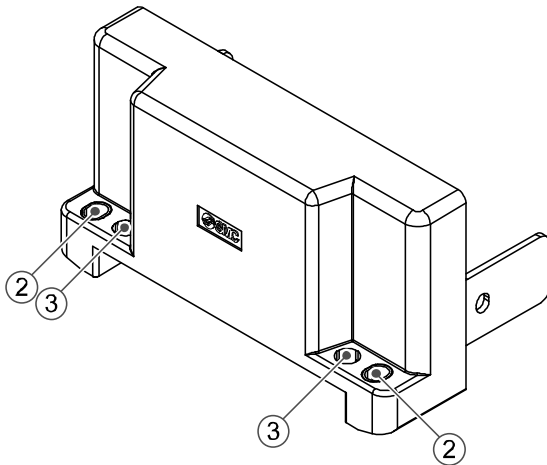

No.	Description	Function
1	Power connector	Connector for power supply to SI unit and I/O unit.
2	Fixing hole for direct mounting	Holes for direct mounting.
3	DIN rail fixing hole	Holes for fix DIN rail mounting.
4	F.E. terminal *	Functional Earth terminal - must be connected directly to system earth (ground).

*: Individual grounding should be provided close to the product with a short cable.

•EX600-ED4/ED5-#

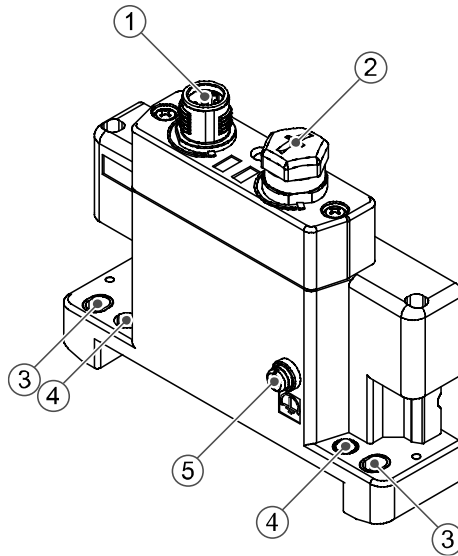

No.	Description	Function
1	Power connector (PWR IN)	Supplies power for each unit and input/output devices.
2	Power connector (PWR OUT)	Provides power to downstream equipment.
3	Fixing hole for direct mounting	Holes used for direct mounting.
4	DIN rail fixing hole	Holes used for fix DIN rail.
5	F.E. terminal *	Functional Earth terminal - must be connected directly to system earth (ground).

*: Individual grounding should be provided close to the product with a short cable.

Mounting and Installation

■Wiring

○Connector pin assignment

(1) EX600-ED2-#

PWR IN: M12 5-pin Plug B-coded

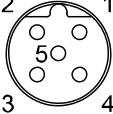
Configuration	Pin No.	Signal name
	1	24 V (Output)
	2	0 V (Output)
	3	24 V (Control and input)
	4	0 V (Control and input)
	5	F.E.

(2) EX600-ED3-#

PWR IN: 7/8 inch 5-pin Plug

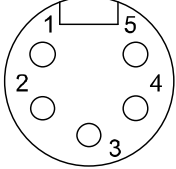
Configuration	Pin No.	Signal name
	1	0 V (Output)
	2	0 V (Control and input)
	3	F.E.
	4	24 V (Control and input)
	5	24 V (Output)

(3) EX600-ED4-#

PWR IN: M12 4-pin Plug A-coded

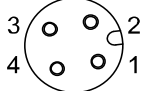
Configuration	Pin No.	Signal name
	1	24 V (Control and input)
	2	24 V (Output)
	3	0 V (Control and input)
	4	0 V (Output)

PWR OUT: M12 5-pin Socket A-coded

Configuration	Pin No.	Signal name
	1	24 V (Control and input)
	2	24 V (Output)
	3	0 V (Control and input)
	4	0 V (Output)
	5	Not used

(4) EX600-ED5-#

PWR IN: M12 4-pin Plug A-coded

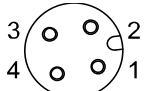
Configuration	Pin No.	Signal name
	1	24 V (Output)
	2	0 V (Output)
	3	24 V (Control and input)
	4	0 V (Control and input)

PWR OUT: M12 5-pin Socket A-coded

Configuration	Pin No.	Signal name
	1	24 V (Output)
	2	0 V (Output)
	3	24 V (Control and input)
	4	0 V (Control and input)
	5	Not used

○Regarding the 2 types of power supply

The power supply consists of two power supply systems as follows:

- Power supply for control and input: Supplying power for control of each unit's power supply for control and also for device connected to input port of Digital and Analogue unit.
- Power supply for output: Supplying power for equipment connected to output port of Digital and Analogue unit, and also power supply for solenoid valve manifold.

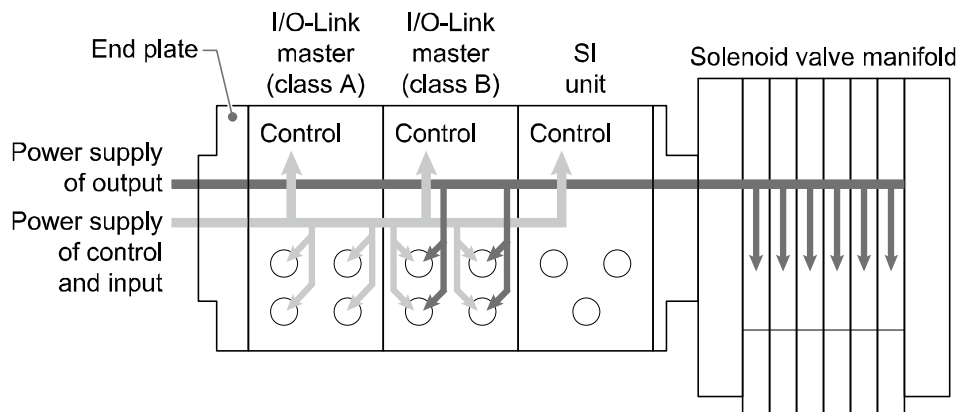
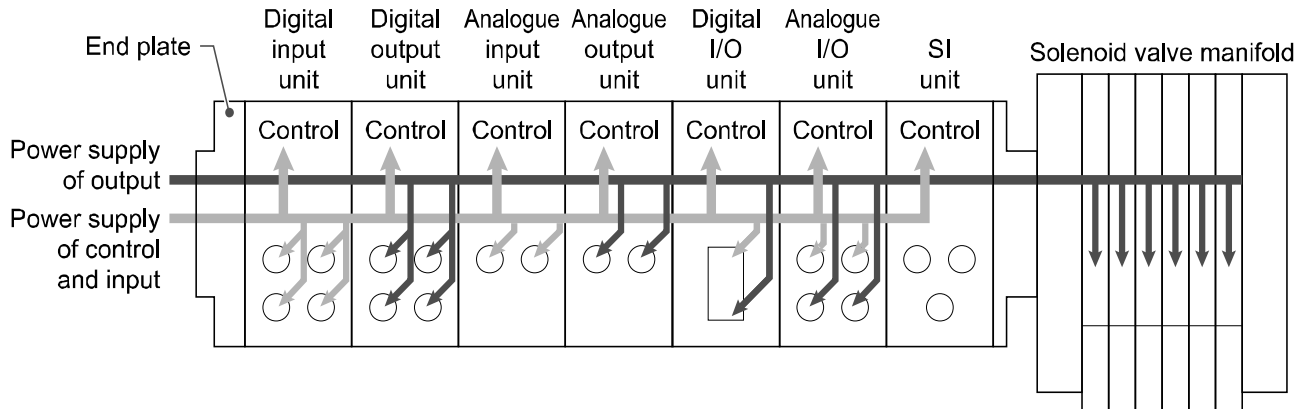

●Precautions for handling

Be sure to fit a seal cap on any unused connectors. Proper use of the seal cap enables the enclosure to achieve IP67 specification.

Specifications

Model		EX600-ED2-#	EX600-ED3-#	EX600-ED4-#	EX600-ED5-#	
Power	Power connector	PWR IN	M12 (5-pin) Plug	7/8 inch (5-pin) Plug	M12 (4-pin) Plug	M12 (4-pin) Plug
		PWR OUT	-	-	M12 (5-pin) Socket	M12 (5-pin) Socket
	Power supply (Control and input)		24 VDC \pm 10%, 2 A	24 VDC \pm 10%, 8 A	DC24 V \pm 10%, 4 A	
	Power supply (Output)		24 VDC +10/-5%, 2 A	24 VDC +10/-5%, 8 A	DC24 V +10/-5%, 4 A	
Environment	Enclosure		IP67 (With manifold assembled) *1			
	Operating temperature range		-10 to 50 °C			
	Storage temperature range		-20 to 60 °C			
	Operating humidity range		35 to 85%R.H. (No condensation)			
	Withstand voltage		500 VAC for 1 minute between external terminals and F.E.			
	Insulation resistance		500 VDC, 10 M Ω min. between external terminals and F.E.			
Standard		UL/CSA(E209424), CE/UKCA marked		CE/UKCA marked		
Weight		170 g	175 g	170 g		

*1: All unused connectors must have a seal cap fitted.

■Dimensions

•EX600-ED2

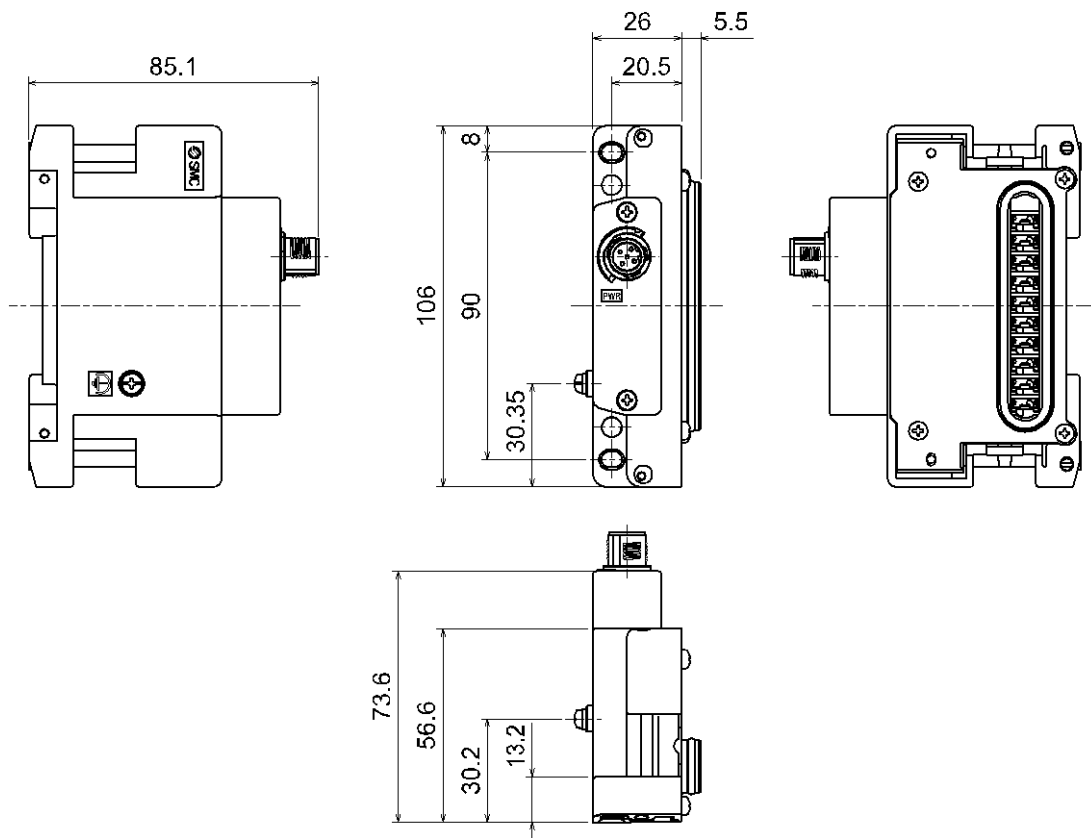

•EX600-ED2-2

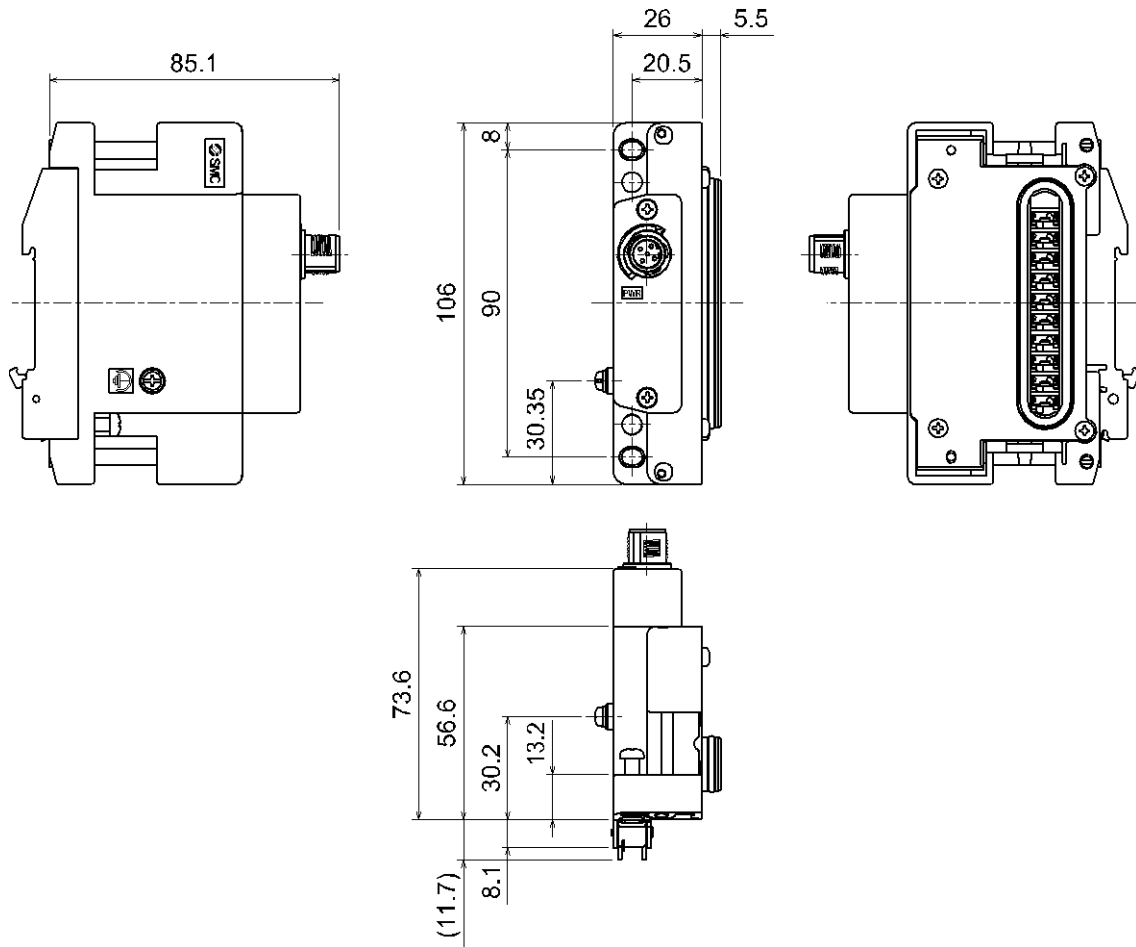

•EX600-ED2-3

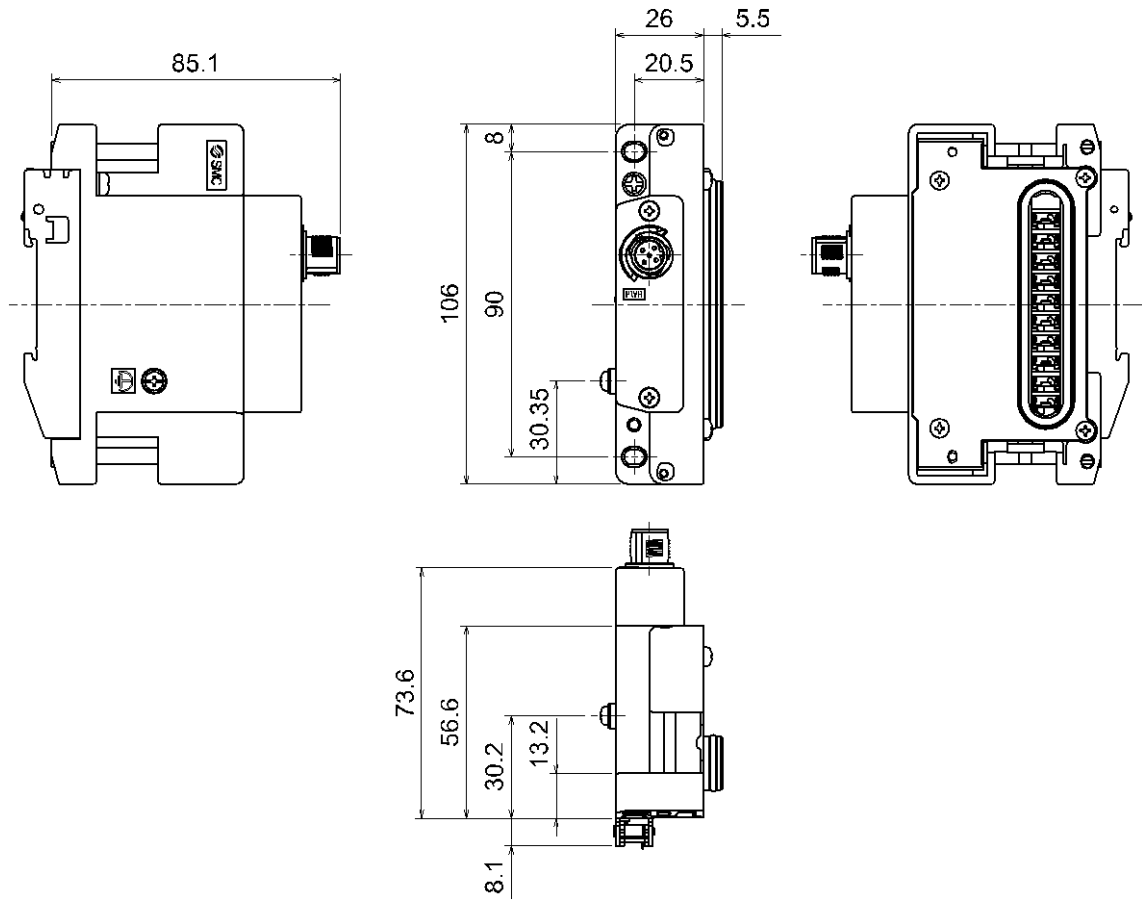

•EX600-ED3

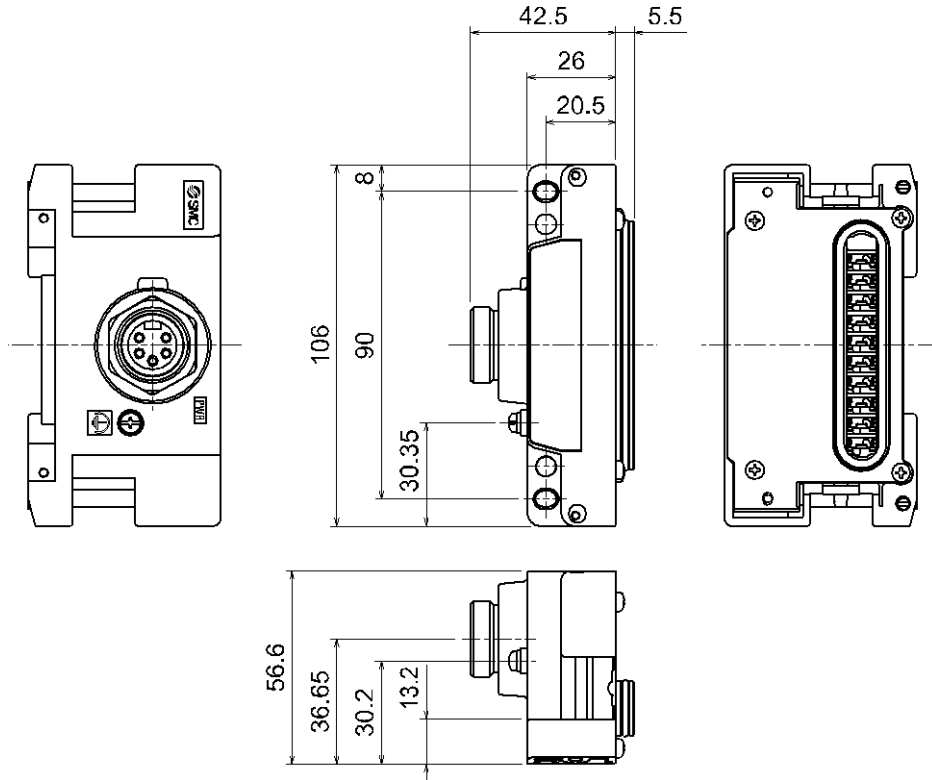

•EX600-ED3-2

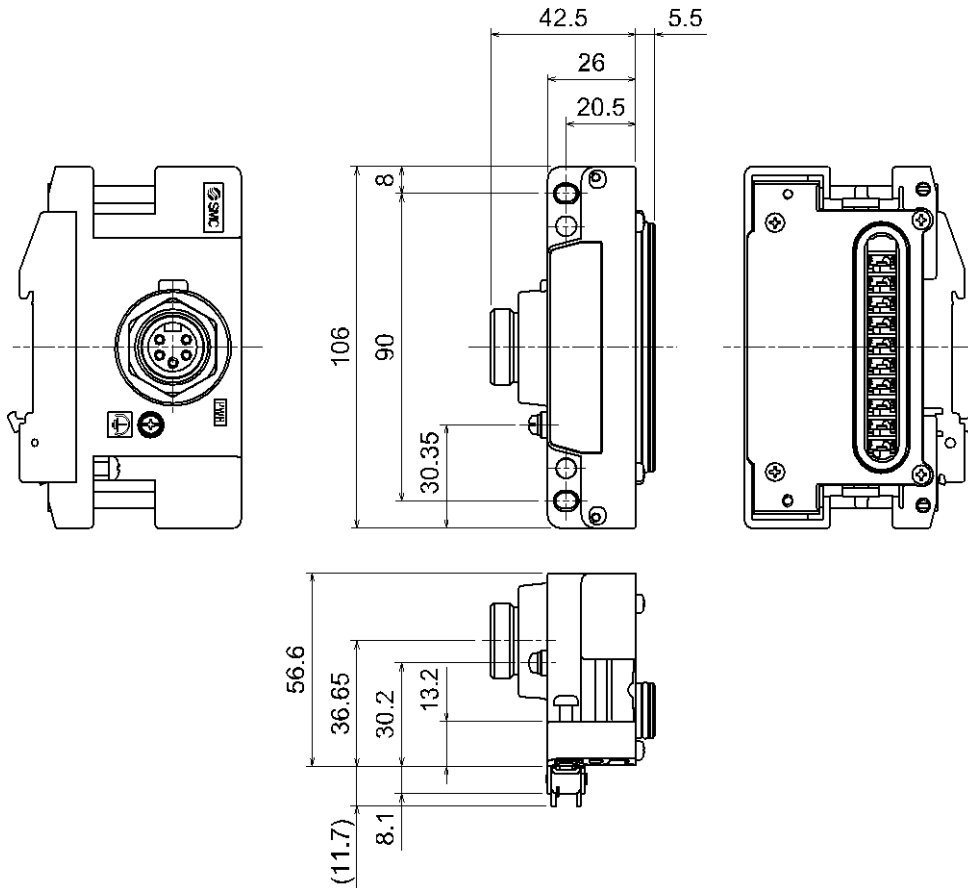

•EX600-ED3-3

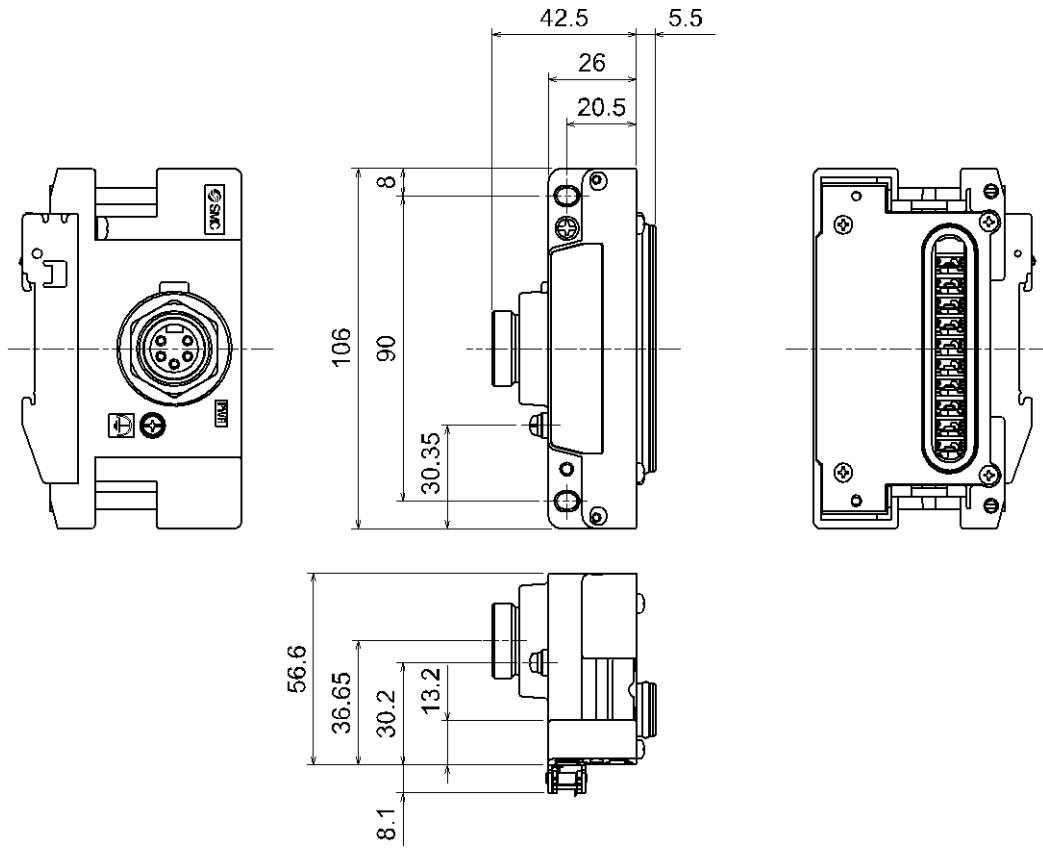

•EX600-ED4/ED5

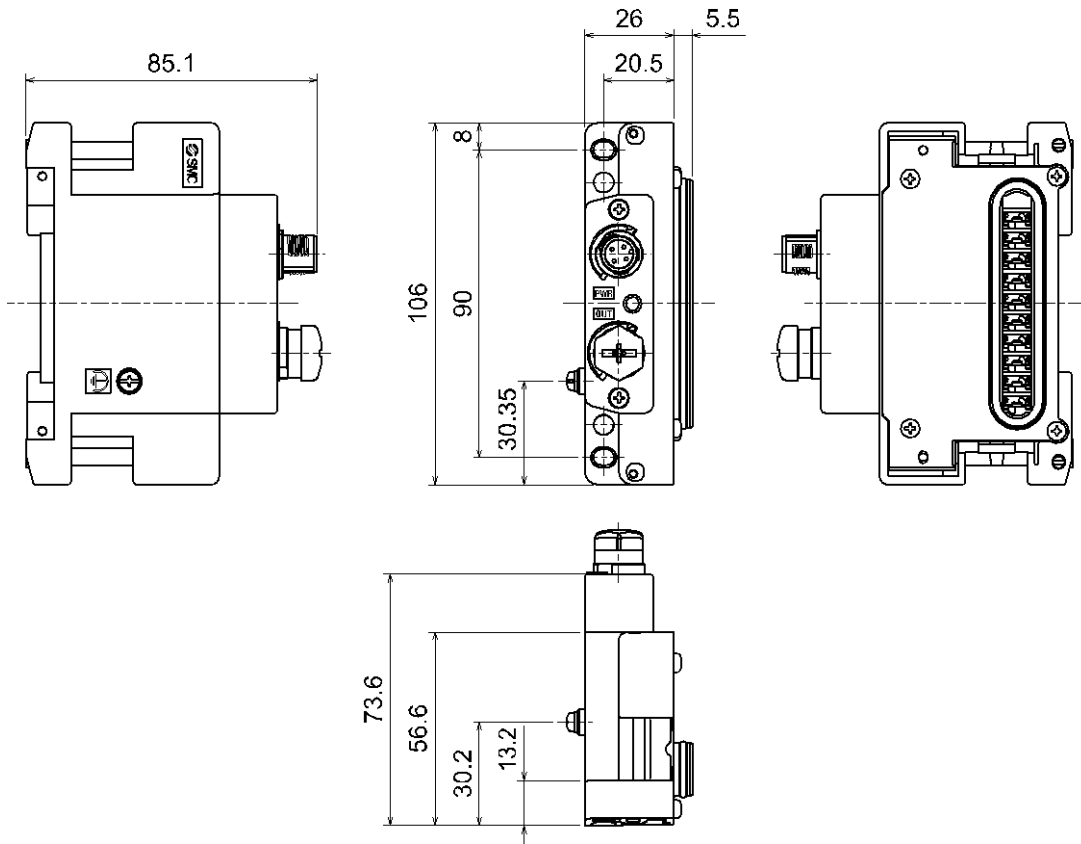

•EX600-ED4/ED5-2

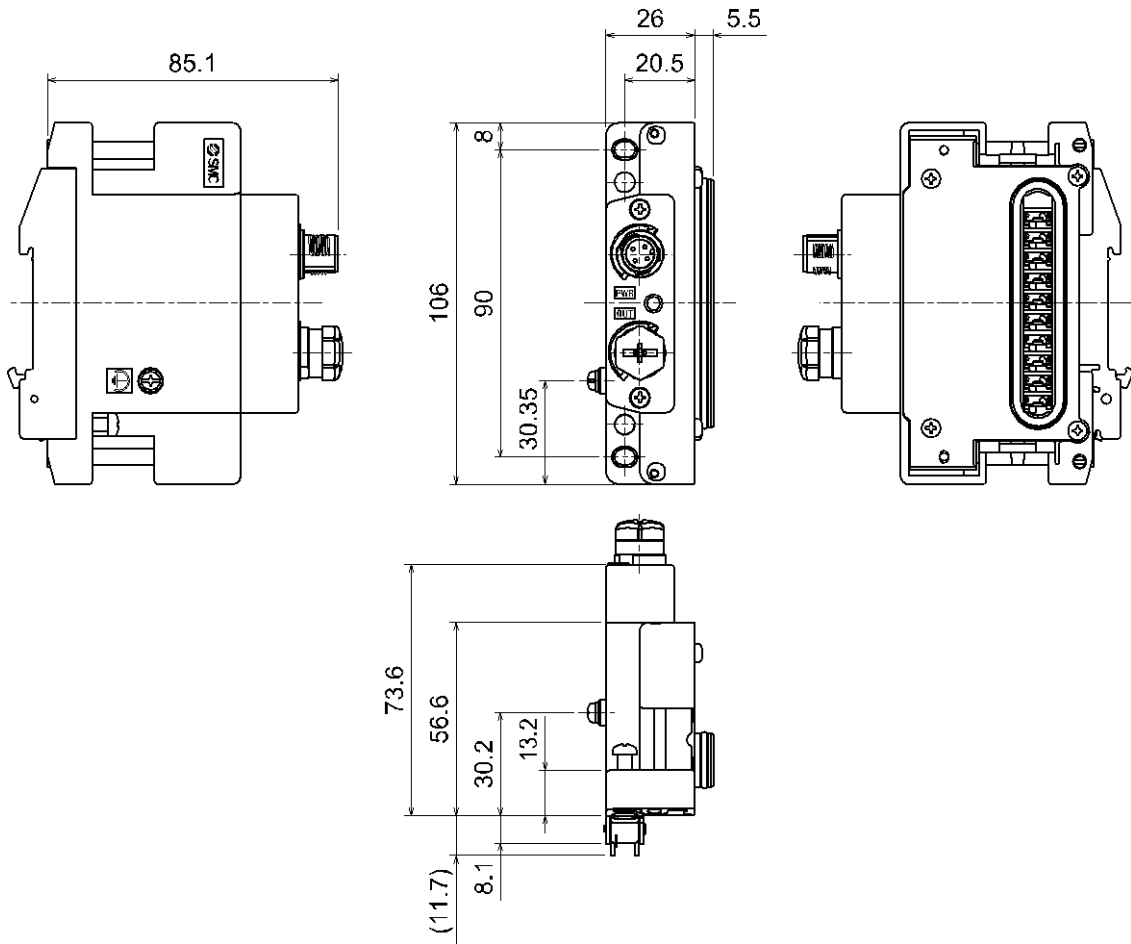

•EX600-ED4/ED5-3

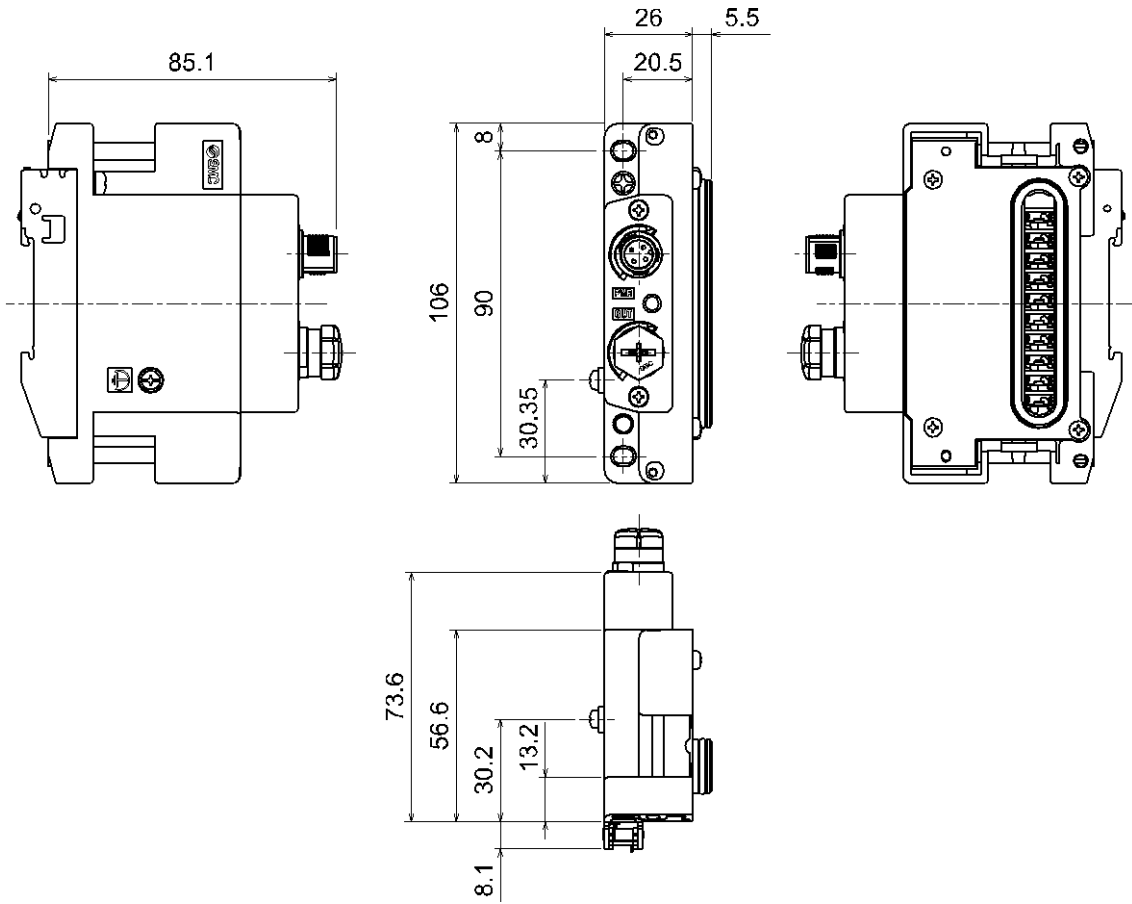

•EX600-EU1

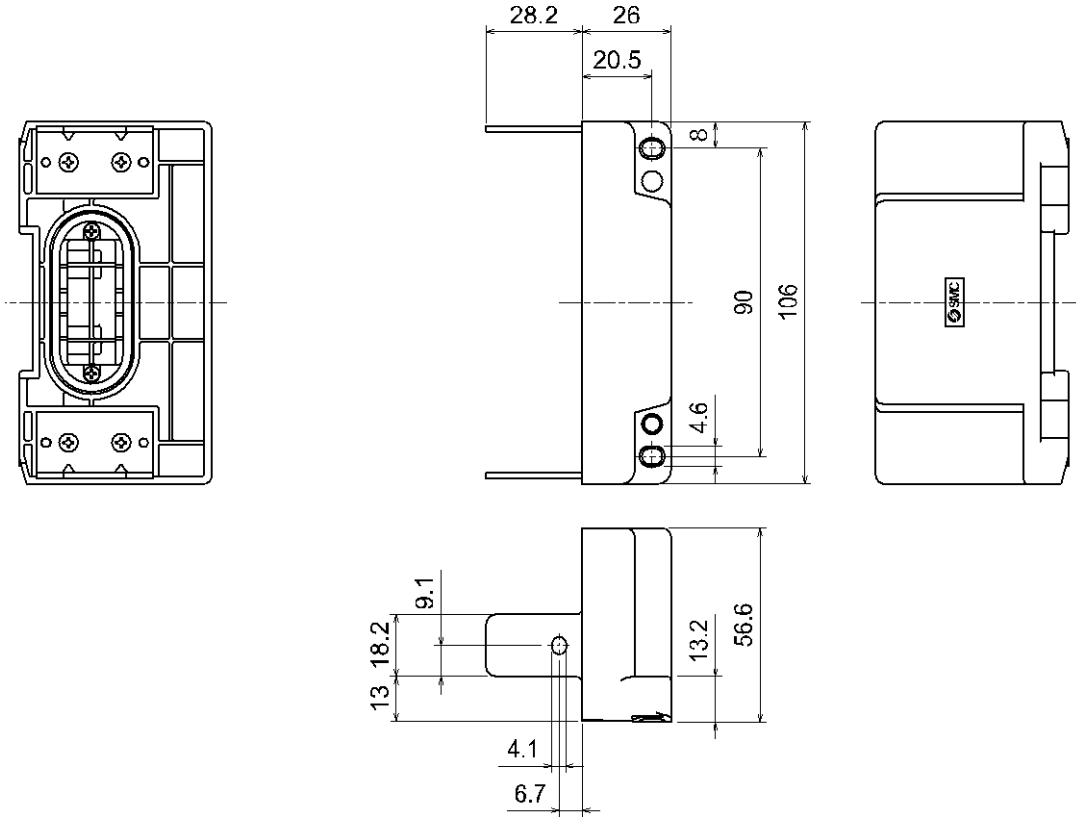

•EX600-EU1-2

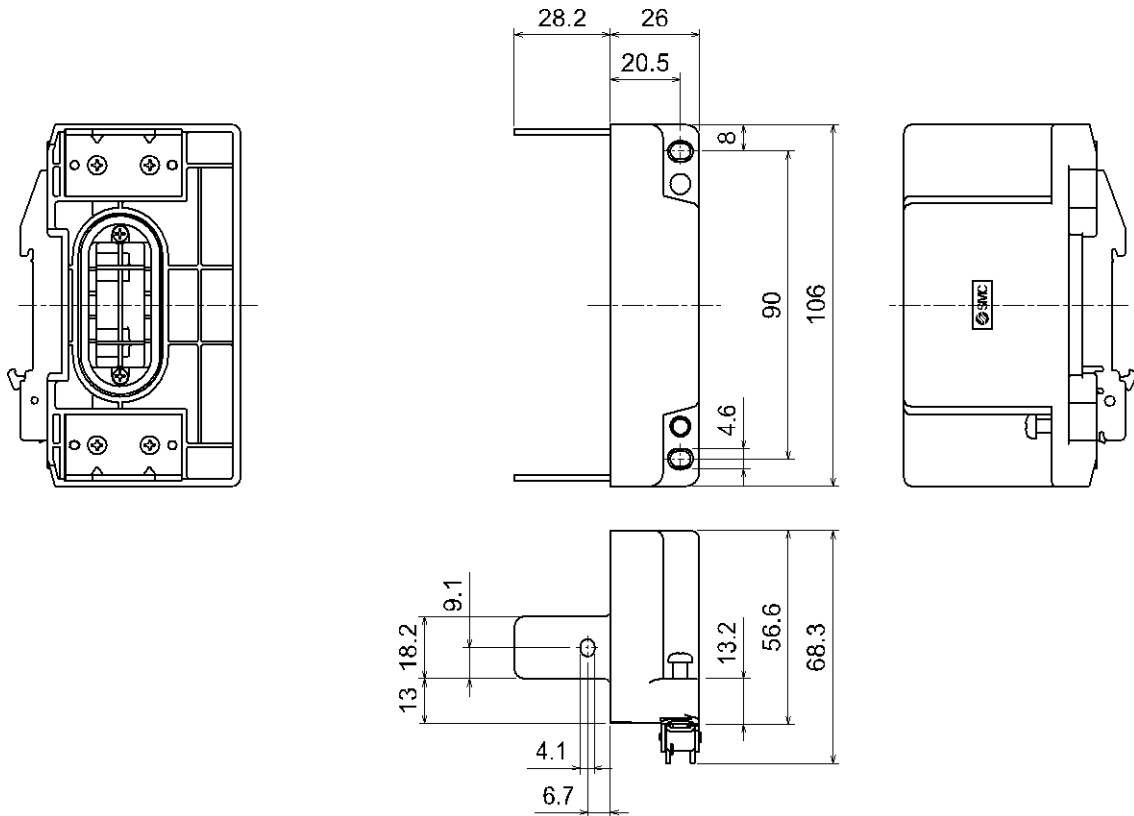

•EX600-EU1-3

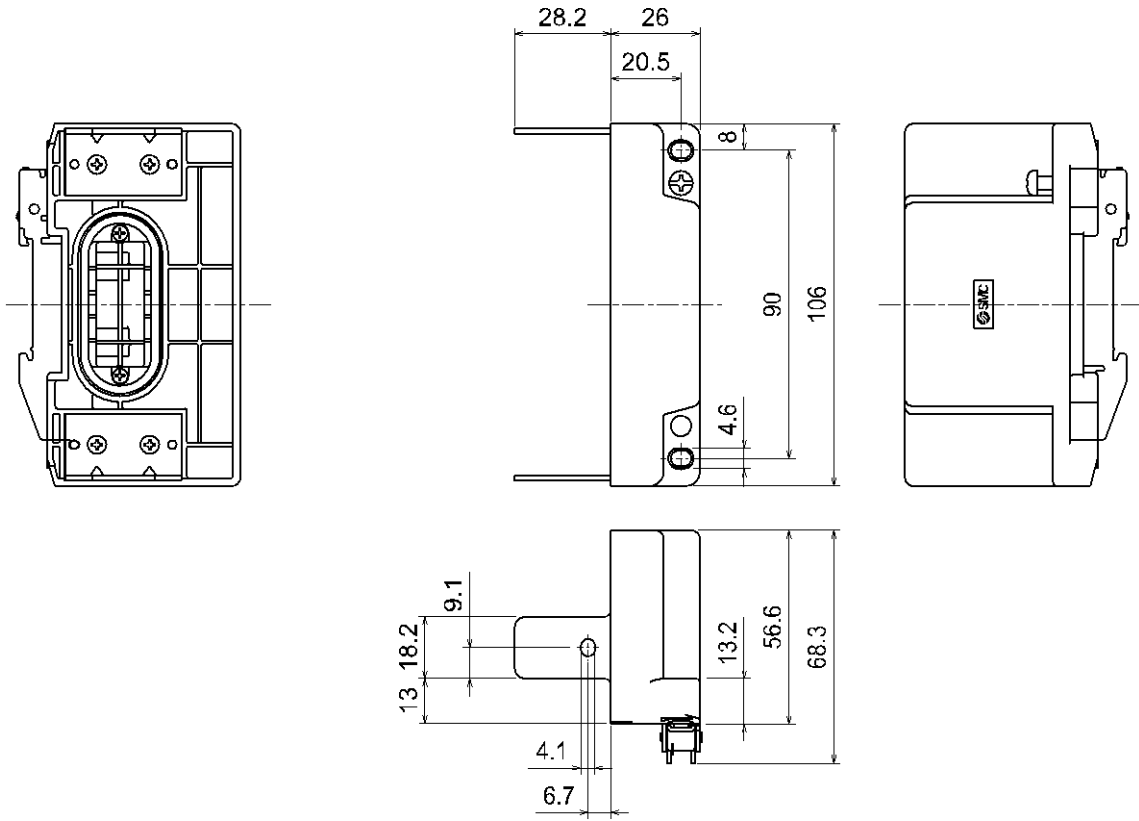

Accessories

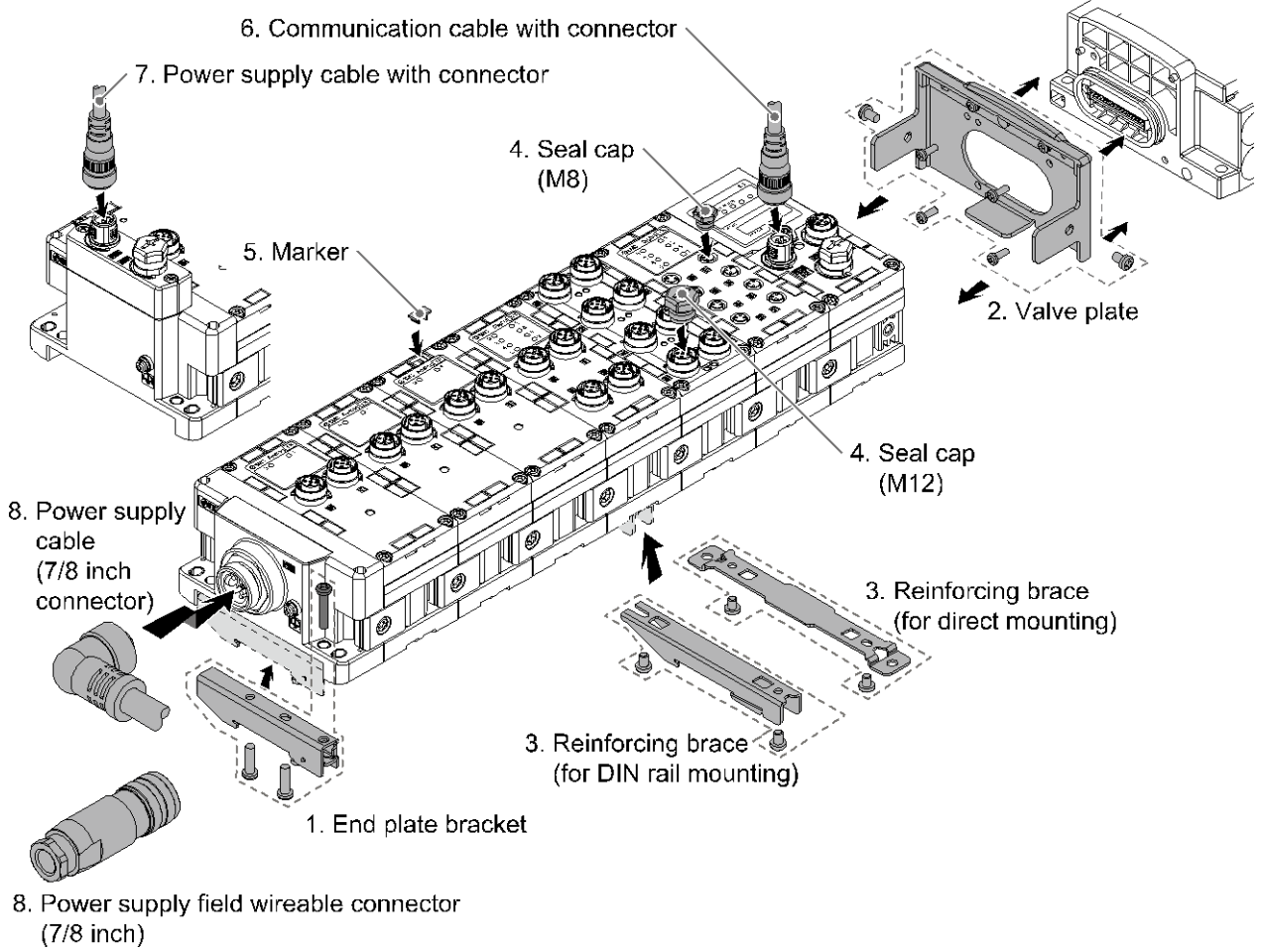

1. End Plate Bracket

This bracket is used for the end plate of DIN rail mounting.

EX600-ZMA2

Enclosed parts: Round head screw (M4 x 20) 1 pc.
P-tight screw (4 x 14) 2 pcs.

EX600-ZMA3 (Specialized for the SY series)

Enclosed parts: Round head screw with washer (M4 x 20) 1 pc.
P-tight screw (4 x 14) 2 pcs.

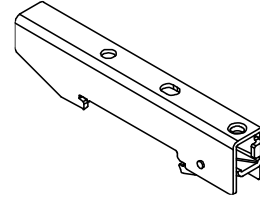

2. Valve Plate

EX600-ZMV1

Enclosed parts: Round head screw (M4 x 6) 2 pcs.
Round head screw (M3 x 8) 4 pcs.

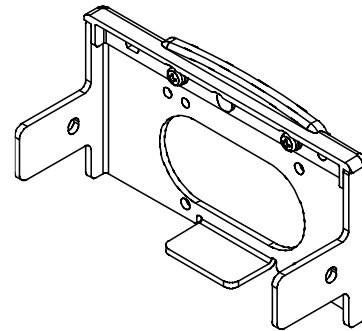

EX600-ZMV2 (Specialized for the SY series)

Enclosed parts: Round head screw (M4 x 6) 2 pcs.
Round head screw (M3 x 8) 2 pcs.

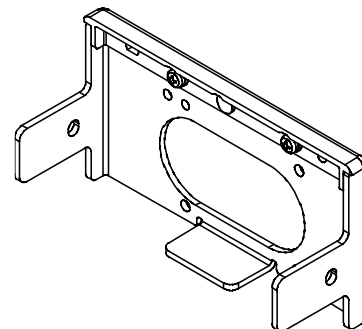

3. Reinforcing Brace

This bracket is used on the bottom of the unit at the intermediate position for connecting 6 units or more.

*: Be sure to attach this bracket to prevent connection failure between the units caused by deflection.

EX600-ZMB1 (For direct mounting)

Enclosed parts: Round head screw (M4 x 5) 2 pcs.

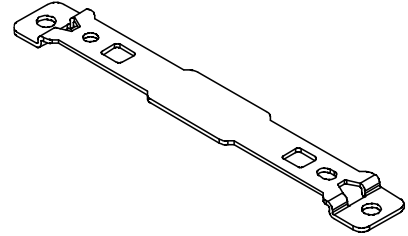

EX600-ZMB2 (For DIN rail mounting)

Enclosed parts: Round head screw (M4 x 6) 2 pcs.

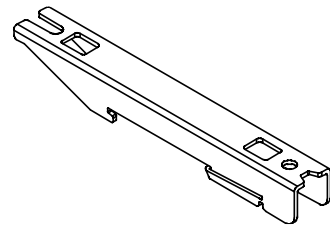

4. Seal Cap (10 pcs.)

Be sure to mount a seal cap on any unused I/O connectors.

Otherwise, the specified enclosure cannot be maintained.

EX9-AWES (For M8)



EX9-AWTS (For M12)



5. Marker (1 sheet, 88 pcs.)

The signal name of I/O device and each unit address can be entered and mounted on each unit.

EX600-ZT1

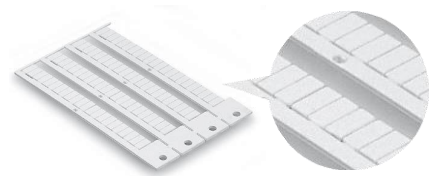

6. Communication Cable/Communication Cable with Connector/Communication Connector
 With connector on both sides (Plug/Plug)

EX9-AC **005** EN-PSPS

• Cable length (L)

Symbol	Content
005	500 mm
010	1000 mm
020	2000 mm
030	3000 mm
050	5000 mm
100	10000 mm

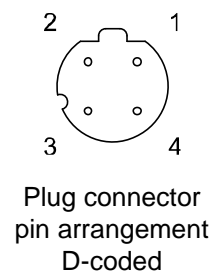
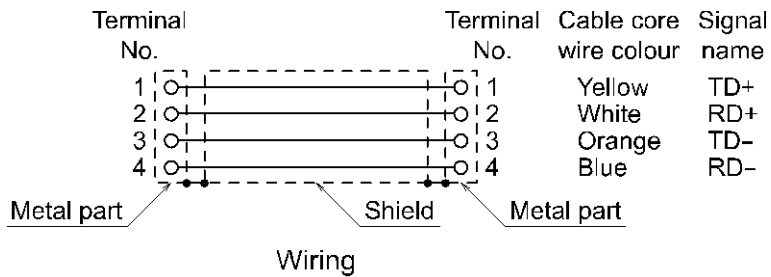
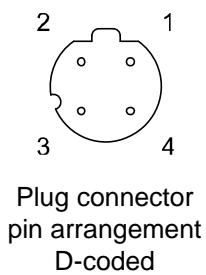
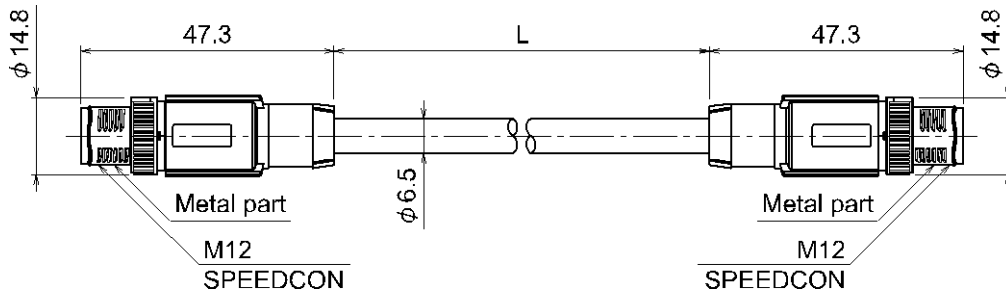

Item	Specifications
Cable O.D.	φ6.5 mm
Conductor nominal cross section	0.34 mm ² /AWG22
Wire O.D. (Including insulator)	1.55 mm
Min. bending radius (Fixed)	19.5 mm

With angled connector on both sides (Plug/Plug)

EX9-AC 005 EN-PAPA

• Cable length (L)

Symbol	Content
005	500 mm
010	1000 mm
020	2000 mm
030	3000 mm
050	5000 mm
100	10000 mm

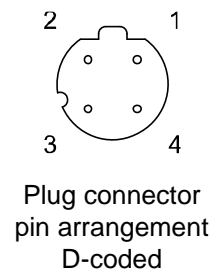
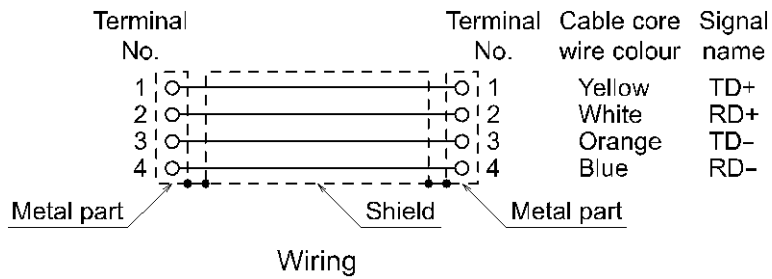
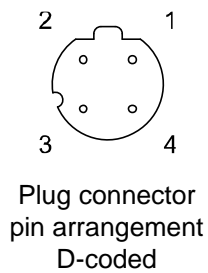
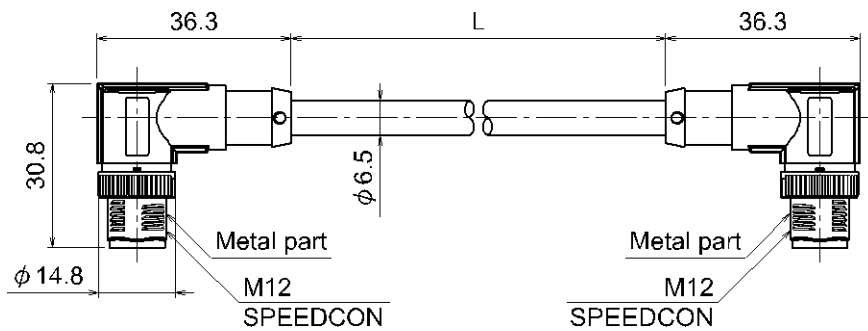

Item	Specifications
Cable O.D.	φ6.5 mm
Conductor nominal cross section	0.34 mm ² /AWG22
Wire O.D. (Including insulator)	1.55 mm
Min. bending radius (Fixed)	19.5 mm

Cable with M12 ↔ RJ-45 connector (Plug/RJ-45 connector)

EX9-AC **020** EN-PSRJ

• Cable length (L)

Symbol	Content
010	1000 mm
020	2000 mm
030	3000 mm
050	5000 mm
100	10000 mm

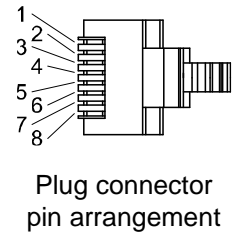
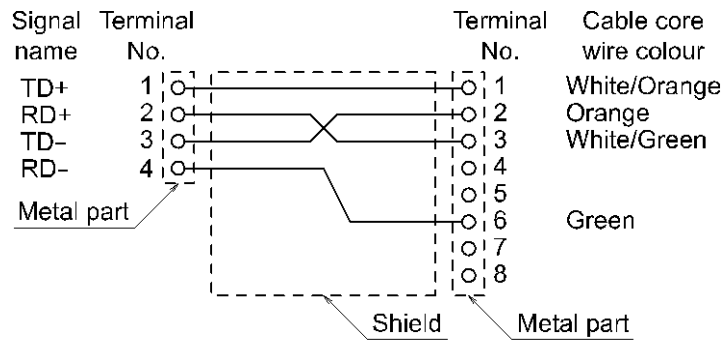
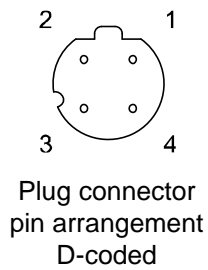
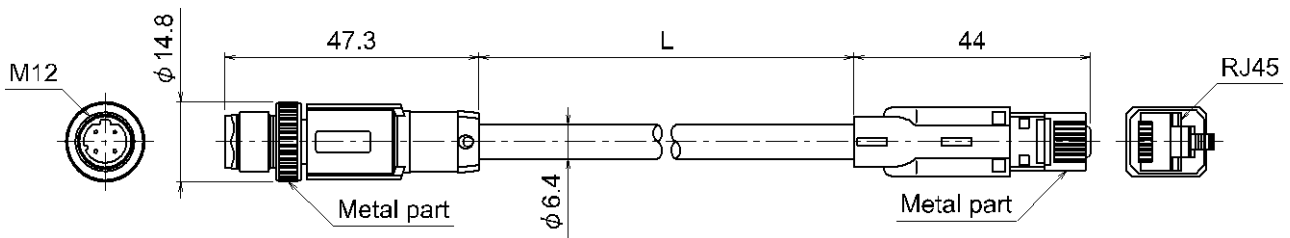

Wiring

Item	Specifications
Cable O.D.	φ6.4 mm
Nominal cross section	0.14 mm ² /AWG26
Wire diameter	0.98 mm
Min. bending radius (Fixed)	26 mm

Cable with connector (Plug)

PCA-1446566

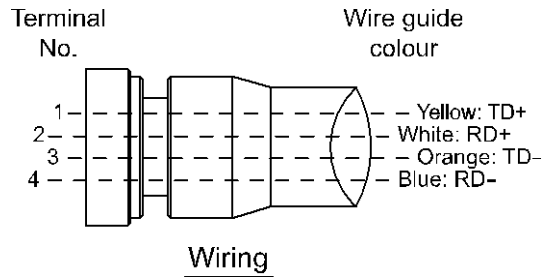
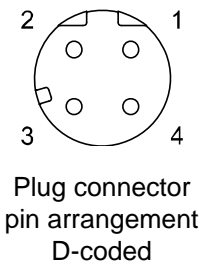
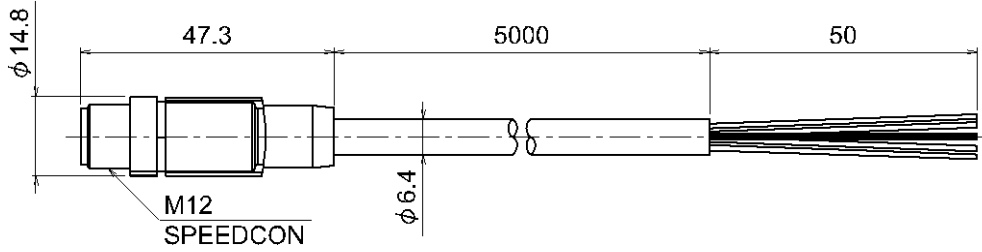

Item	Specifications
Cable O.D.	φ6.5 mm
Nominal cross section	AWG22
Wire diameter (Including insulator)	1.5 mm
Min. bending radius (Fixed)	45.5 mm

Field wireable connector

PCA-1446553

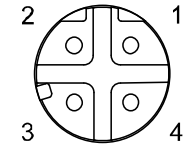
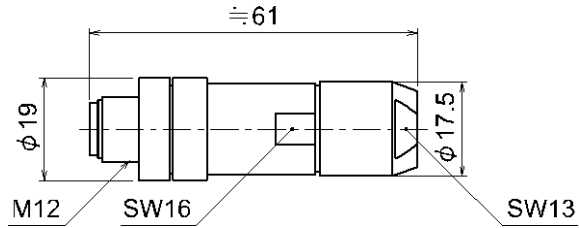

Plug connector
pin arrangement
D-coded

Terminal No.	Wire guide colors
1	Orange/White
2	Green/White
3	Orange
4	Green

Applicable Cable

Item	Specifications
Cable O.D.	4.0 to 8.0 mm
Wire gauge (Stranded wire cross section)	0.14 to 0.34 mm ² / AWG26 to 22

*: The table above shows the specifications for the applicable cable.
Adaptation for the connector may vary on account of the conductor
construction of the electric wire.

7. Power Supply Cable with M12 Connector (A-coded)

EX9-AC **005**-SSPS

• Cable length (L)

Symbol	Content
005	500 mm
010	1000 mm
020	2000 mm
030	3000 mm
050	5000 mm
100	10000 mm

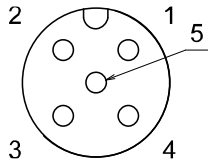
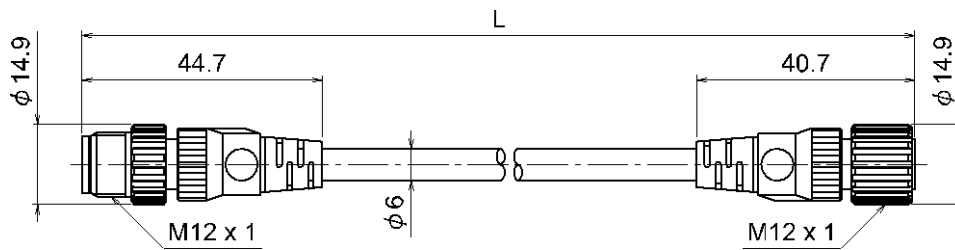

Socket connector
pin arrangement
A-coded
(Normal key)

Terminal No.	Terminal No.	Cable core wire colour
1	1	Brown
2	2	White
3	3	Blue
4	4	Black
5	5	Grey

Wiring

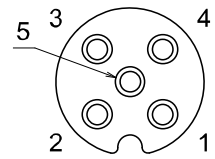

Plug connector
pin arrangement
A-coded
(Normal key)

Item	Specifications
Cable O.D.	φ6.5 mm
Conductor nominal cross section	0.34 mm ² /AWG22
Wire O.D. (Including conductor)	1.55 mm
Min. bending radius (Fixed)	19.5 mm

EX500-AP **050** - **S**

Cable length (L)

Symbol	Content
010	1000 mm
050	5000 mm

Connector specification

Symbol	Content
S	Straight
A	Right angle

Straight connector type

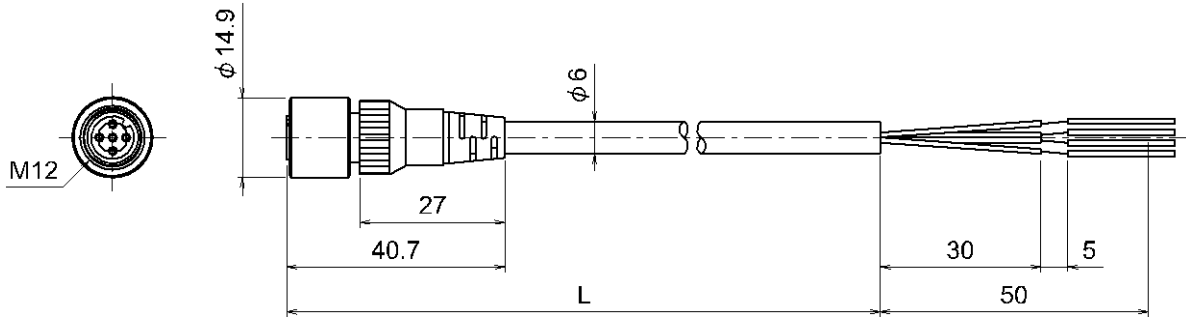

Angle connector type

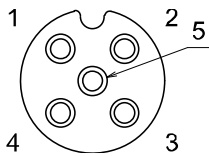
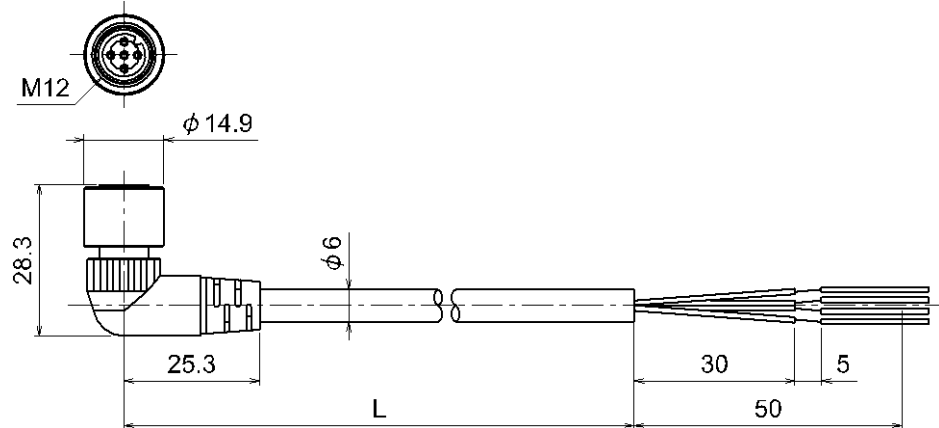

Socket connector
pin arrangement
A-coded
(Normal key)

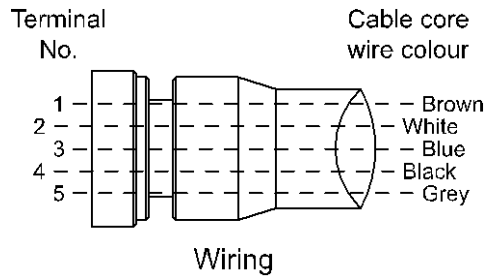

Item	Specifications
Cable O.D.	φ6 mm
Nominal cross section	0.3 mm ² /AWG22
Wire diameter (Including insulator)	1.5 mm
Min. bending radius (Fixed)	40 mm

SPEEDCON

PCA-1401804

• Cable length (L)

Symbol	Content
1401804	1500 mm
1401805	3000 mm
1401806	5000 mm

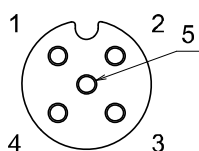
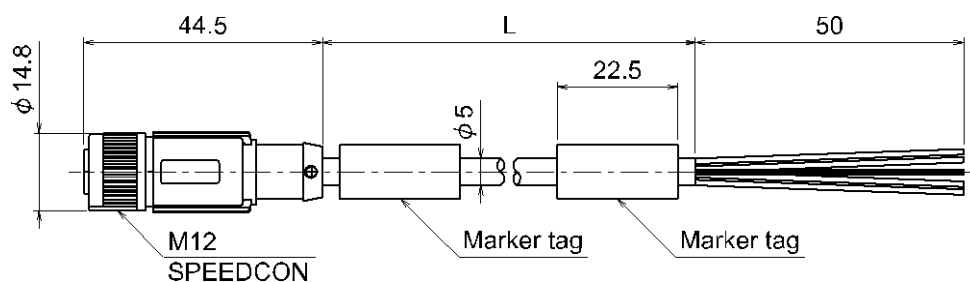

Socket connector
pin arrangement
A-coded
(Normal key)

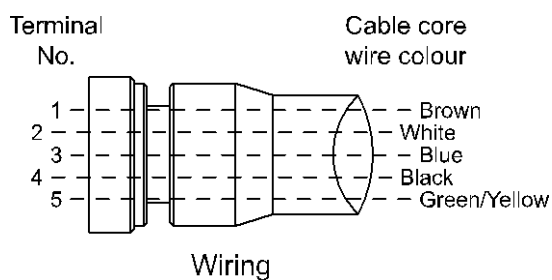

Item	Specifications
Cable O.D.	$\phi 5$ mm
Nominal cross section	0.3 mm ² /AWG22
Wire diameter (Including insulator)	1.27 mm
Min. bending radius (Fixed)	21.7 mm

PCA-1557769

• Cable length (L)

Symbol	Content
1557769	3000 mm

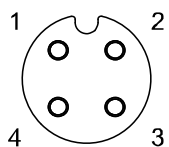
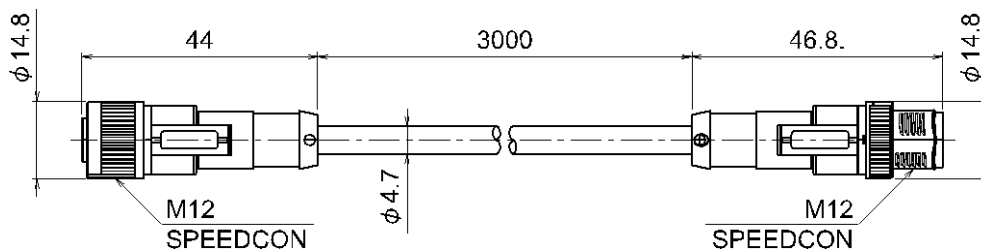

Socket connector
pin arrangement
A-coded
(Normal key)

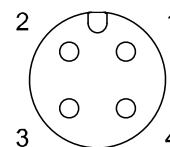
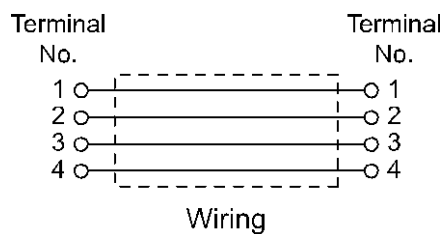

Plug connector
pin arrangement
A-coded
(Normal key)

7. Power Supply Cable with M12 Connector (B-coded)

SPEEDCON

PCA-1564927

• Specification

Symbol	Cable length (L)	Connector specification
1564927	2000 mm	Straight
1564930	6000 mm	Straight
1564943	2000 mm	Right angle
1564969	6000 mm	Right angle

Straight connector type

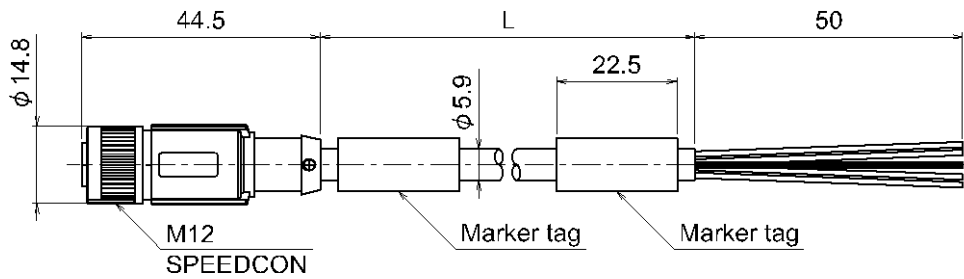

Angle connector type

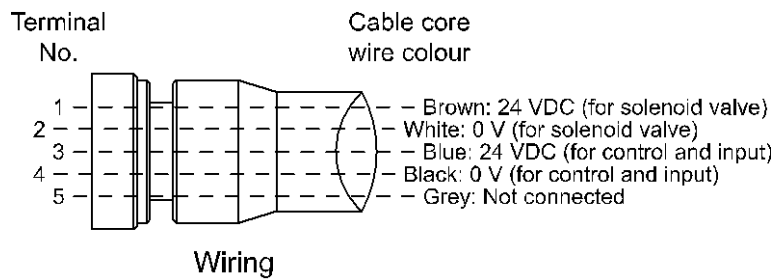
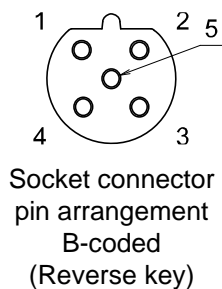
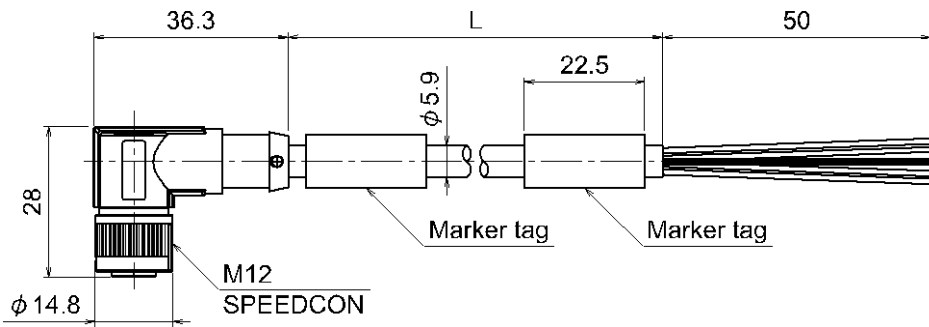

8. Power Supply Cable with 7/8 Inch Connector/Power Supply Connector

PCA-1558810

• Specification

Symbol	Cable length (L)	Connector specification
1558810	2000 mm	Straight
1558823	6000 mm	Straight
1558836	2000 mm	Right angle
1558849	6000 mm	Right angle

Straight connector type

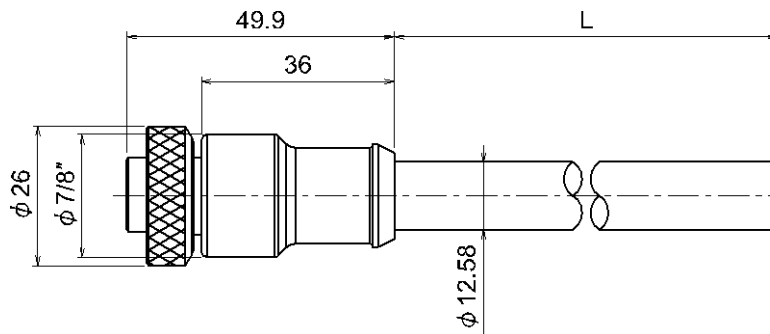

Angle connector type

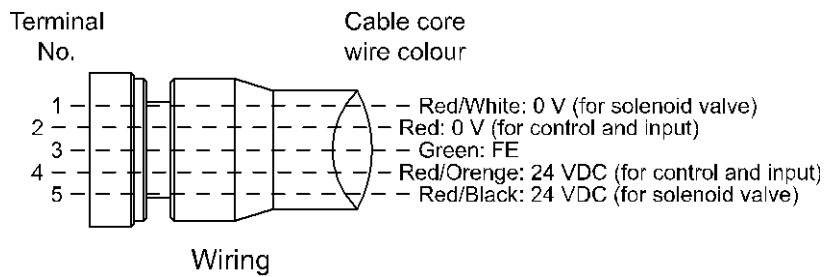
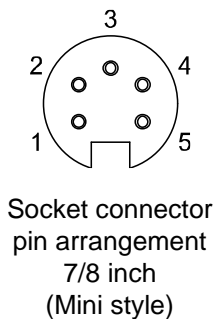
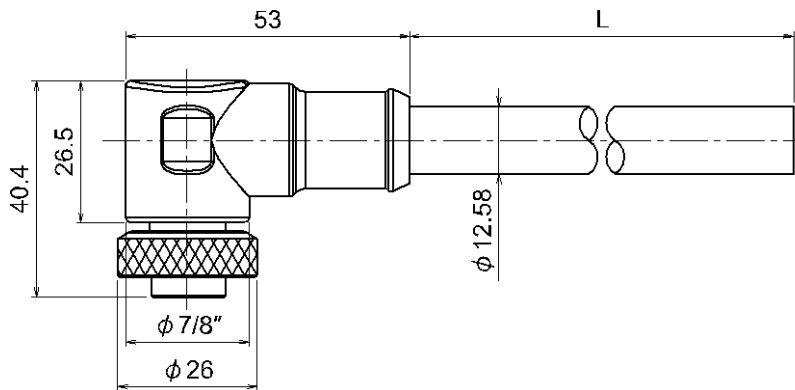

Field wireable connector

PCA-1578078

• Connector specification

Symbol	Content
1578078	Plug
1578081	Socket

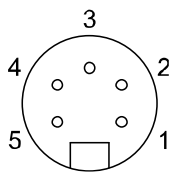
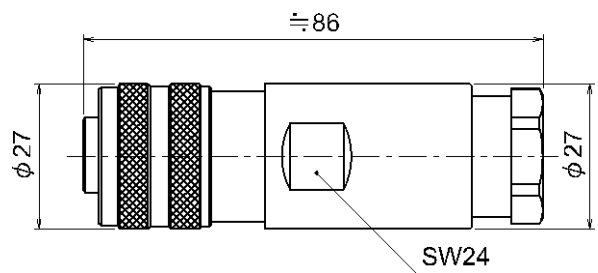
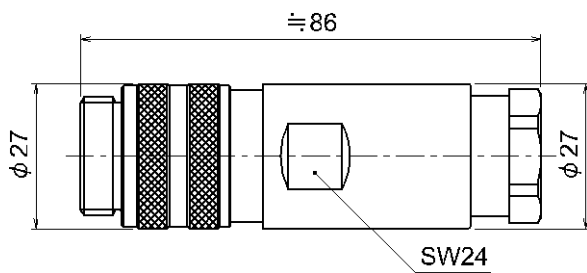

Plug connector
pin arrangement
7/8 inch
(Mini style)

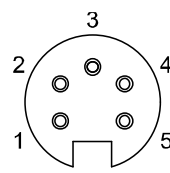

Socket connector
pin arrangement
7/8 inch
(Mini style)

Terminal No.	Wire guide colors
1	Red/White
2	Red
3	Green
4	Red/Orange
5	Red/Black

Applicable Cable

Item	Specifications
Cable O.D.	12.0 to 14.0 mm
Wire gauge (Stranded wire cross section)	0.34 to 1.5 mm ² / AWG22 to 16

*: The table above shows the specifications for the applicable cable.
Adaptation for the connector may vary on account of the conductor
construction of the electric wire.

Revision history

A: Contents are added. [May 2018]
B: Contents revised in several places.
[January 2019]
C: Contents are added. [May 2019]
D: Contents are added. [January 2022]
E: Contents revised in several places. [May 2023]
F: Content changes. [May 2024]
G: Contents are added. [February 2025]

SMC Corporation

Tel: + 81 3 5207 8249 Fax: +81 3 5298 5362

URL <https://www.smcworld.com>

Note: Specifications are subject to change without prior notice and any obligation on the part of the manufacturer.

EtherNet/IP® is a registered trademark of ODVA, Inc.

© SMC Corporation All Rights Reserved

