



Operation Manual

PRODUCT NAME

Fieldbus system
PROFIBUS DP compatible SI unit

MODEL / Series / Product Number

EX600-SPR#A
EX600-ED#

SMC Corporation

Table of Contents

Safety Instructions	3
System Outline	9
Definition and terminology	10
Assembly	12
Mounting and Installation	14
Installation	14
Wiring	16
SI Unit	
Model Indication and How to Order	17
Summary of Product parts	17
Mounting and Installation	18
Wiring	18
Setting and Adjustment	19
LED Display	23
Specifications	25
Dimensions	26
End plate	
Model Indication and How to Order	27
Summary of Product parts	28
Mounting and Installation	30
Wiring	30
Specifications	32
Dimensions	33
Maintenance	43
Troubleshooting	44
Parameter Setting	53
Parameter definition and setting	53
Hardware Configuration	64
GSD file and icon	64
Configuration layout	64
SIEMENS PLC S7™ connection method	65
Parameter setting at PLC	68
I/O Map	70
Diagnostic	71
Accessories	79



Safety Instructions

These safety instructions are intended to prevent hazardous situations and/or equipment damage. These instructions indicate the level of potential hazard with the labels of “**Caution**,” “**Warning**” or “**Danger**.” They are all important notes for safety and must be followed in addition to International Standards (ISO/IEC)^{*)}, and other safety regulations.

*1) ISO 4414: Pneumatic fluid power - General rules and safety requirements for systems and their components
ISO 4413: Hydraulic fluid power - General rules and safety requirements for systems and their components
IEC 60204-1: Safety of machinery - Electrical equipment of machines - Part 1: General requirements
ISO 10218-1: Robots and robotic devices - Safety requirements for industrial robots - Part 1: Robots
etc.



Danger

Danger indicates a hazard with a high level of risk which, if not avoided, will result in death or serious injury.



Warning

Warning indicates a hazard with a medium level of risk which, if not avoided, could result in death or serious injury.



Caution

Caution indicates a hazard with a low level of risk which, if not avoided, could result in minor or moderate injury.



Warning

1. The compatibility of the product is the responsibility of the person who designs the equipment or decides its specifications.

Since the product specified here is used under various operating conditions, its compatibility with specific equipment must be decided by the person who designs the equipment or decides its specifications based on necessary analysis and test results. The expected performance and safety assurance of the equipment will be the responsibility of the person who has determined its compatibility with the product. This person should also continuously review all specifications of the product referring to its latest catalog information, with a view to giving due consideration to any possibility of equipment failure when configuring the equipment.

2. Only personnel with appropriate training should operate machinery and equipment.

The product specified here may become unsafe if handled incorrectly. The assembly, operation and maintenance of machines or equipment including our products must be performed by an operator who is appropriately trained and experienced.

3. Do not service or attempt to remove product and machinery/equipment until safety is confirmed.

1. The inspection and maintenance of machinery/equipment should only be performed after measures to prevent falling or runaway of the driven objects have been confirmed.
2. When the product is to be removed, confirm that the safety measures as mentioned above are implemented and the power from any appropriate source is cut, and read and understand the specific product precautions of all relevant products carefully.
3. Before machinery/equipment is restarted, take measures to prevent unexpected operation and malfunction.

4. Our products cannot be used beyond their specifications. Our products are not developed, designed, and manufactured to be used under the following conditions or environments. Use under such conditions or environments is not covered.

1. Conditions and environments outside of the given specifications, or use outdoors or in a place exposed to direct sunlight.
2. Use for nuclear power, railways, aviation, space equipment, ships, vehicles, military application, equipment affecting human life, body, and property, fuel equipment, entertainment equipment, emergency shut-off circuits, press clutches, brake circuits, safety equipment, etc., and use for applications that do not conform to standard specifications such as catalogs and operation manuals.
3. Use for interlock circuits, except for use with double interlock such as installing a mechanical protection function in case of failure. Please periodically inspect the product to confirm that the product is operating properly.



Safety Instructions

Caution

We develop, design, and manufacture our products to be used for automatic control equipment, and provide them for peaceful use in manufacturing industries.

Use in non-manufacturing industries is not covered.

Products we manufacture and sell cannot be used for the purpose of transactions or certification specified in the Measurement Act.

The new Measurement Act prohibits use of any unit other than SI units in Japan.

Limited warranty and Disclaimer/Compliance Requirements

The product used is subject to the following “Limited warranty and Disclaimer” and “Compliance Requirements”.

Read and accept them before using the product.

Limited warranty and Disclaimer

1. The warranty period of the product is 1 year in service or 1.5 years after the product is delivered, whichever is first.*2)
Also, the product may have specified durability, running distance or replacement parts. Please consult your nearest sales branch.
2. For any failure or damage reported within the warranty period which is clearly our responsibility, a replacement product or necessary parts will be provided.
This limited warranty applies only to our product independently, and not to any other damage incurred due to the failure of the product.
3. Prior to using SMC products, please read and understand the warranty terms and disclaimers noted in the specified catalog for the particular products.

***2) Vacuum pads are excluded from this 1 year warranty.**

A vacuum pad is a consumable part, so it is warranted for a year after it is delivered.

Also, even within the warranty period, the wear of a product due to the use of the vacuum pad or failure due to the deterioration of rubber material are not covered by the limited warranty

Compliance Requirements

1. The use of SMC products with production equipment for the manufacture of weapons of mass destruction (WMD) or any other weapon is strictly prohibited.
2. The exports of SMC products or technology from one country to another are governed by the relevant security laws and regulations of the countries involved in the transaction. Prior to the shipment of a SMC product to another country, assure that all local rules governing that export are known and followed.

Operator

- ◆ This operation manual is intended for those who have knowledge of machinery using pneumatic equipment, and have sufficient knowledge of assembly, operation and maintenance of such equipment. Only those persons are allowed to perform assembly, operation and maintenance.
- ◆ Read and understand this operation manual carefully before assembling, operating or providing maintenance to the product.

■ Safety Instructions

Warning

- Do not disassemble, modify (including changing the printed circuit board) or repair.
An injury or failure can result.
- Do not operate or set with wet hands.
This may lead to an electric shock.
- Do not operate the product outside of the specifications.
Do not use for flammable or harmful fluids.
Fire, malfunction, or damage to the product can result.
Verify the specifications before use.
- Do not operate in an atmosphere containing flammable or explosive gases.
Fire or an explosion can result.
This product is not designed to be explosion proof.
- If using the product in an interlocking circuit:
 - Provide a double interlocking system, for example a mechanical system.
 - Check the product regularly for proper operation.Otherwise malfunction can result, causing an accident.
- The following instructions must be followed during maintenance:
 - Turn off the power supply.
 - Stop the air supply, exhaust the residual pressure and verify that the air is released before performing maintenance.Otherwise an injury can result.

Caution

- When handling the unit or assembling/replacing units:
 - Do not touch the sharp metal parts of the connector or plug for connecting units.
 - Take care not to hit your hand when disassembling the unit.
The connecting portions of the unit are firmly joined with seals.
 - When joining units, take care not to get fingers caught between units.
An injury can result.

- After maintenance is complete, perform appropriate functional inspections.
Stop operation if the equipment does not function properly.
Safety cannot be assured in the case of unexpected malfunction.

- Provide grounding to assure the noise resistance of the Fieldbus system.
Individual grounding should be provided close to the product with a short cable.

■ NOTE

- Follow the instructions given below when designing, selecting and handling the product.
 - The instructions on design and selection (installation, wiring, environment, adjustment, operation, maintenance, etc.) described below must also be followed.
 - *Product specifications
 - The direct current power supply to combine should be UL1310 Class 2 power supply when conformity to UL is necessary.
 - Use the specified voltage.
Otherwise failure or malfunction can result.
 - Reserve a space for maintenance.
Allow sufficient space for maintenance when designing the system.
 - Do not remove any nameplates or labels.
This can lead to incorrect maintenance, or misreading of the operation manual, which could cause damage or malfunction to the product.
It may also result in non-conformity to safety standards.
 - Beware of inrush current when the power supply is turned on.
Some connected loads can apply an initial charge current which will activate the over current protection function, causing the unit to malfunction.

●Product handling

*Installation

- Do not drop, hit or apply excessive shock to the SI unit.

Otherwise damage to the product can result, causing malfunction.

- Tighten to the specified tightening torque.

If the tightening torque is exceeded the mounting screws may be broken.

IP67 protection cannot be guaranteed if the screws are not tightened to the specified torque.

- If a large manifold valve is mounted, lift the unit so that stress is not applied to the connecting part while transporting.

The stress may cause breakage of the connecting part. The unit may become very heavy depending on the combination. Transportation/installation shall be performed by multiple operators.

- Never mount a product in a location that will be used as a foothold.

The product may be damaged if excessive force is applied by stepping or climbing onto it.

*Wiring

- Avoid repeatedly bending or stretching the cables, or placing heavy load on them.

Repetitive bending stress or tensile stress can cause breakage of the cable.

- Wire correctly.

Incorrect wiring can break the product.

- Do not perform wiring while the power is on.

Otherwise damage to the SI unit and/or input or output device can result, causing malfunction.

- Do not route wires and cables together with power or high voltage cables.

Otherwise the SI unit and/or input or output device can malfunction due to interference of noise and surge voltage from power and high voltage cables to the signal line.

Route the wires (piping) of the SI unit and/or input or output device separately from power or high voltage cables.

- Confirm proper insulation of wiring.

Poor insulation (interference from another circuit, poor insulation between terminals, etc.) can lead to excess voltage or current being applied to the product, causing damage.

- Take appropriate measures against noise, such as using a noise filter, when the Fieldbus system is incorporated into equipment.

Otherwise noise can cause malfunction.

*Environment

- Select the proper type of protection according to the environment of operation.

IP67 protection is achieved when the following conditions are met.

(1) The units are connected properly with fieldbus cable with M12 connector and power cable with M12 (M8) connector.

(2) Suitable mounting of each unit and manifold valve.

(3) Be sure to fit a waterproof cap on any unused connectors.

If using in an environment that is exposed to water splashes, please take measures such as using a cover.

Do not use in an environment where moisture or water vapor are present. Otherwise failure and malfunction can result.

- Do not use in a place where the product could be splashed by oil or chemicals.

If the product is to be used in an environment containing oils or chemicals such as coolant or cleaning solvent, even for a short time, it may be adversely affected (damage, malfunction etc.).

- Do not use the product in an environment where corrosive gases or fluids could be splashed.

Otherwise damage to the product and malfunction can result.

- Do not use in an area where surges are generated.

If there is equipment generating large surge near the unit (magnetic type lifter, high frequency inductive furnace, welding machine, motor, etc.), this can cause deterioration of the internal circuitry element of the unit or result in damage. Take measures against the surge sources, and prevent the lines from coming into close contact.

- When a surge-generating load such as a relay, valve or lamp is driven directly, use a product with a built-in surge absorbing element.
Direct drive of a load generating surge voltage can damage the unit.
- The product is CE/UKCA marked, but not immune to lightning strikes. Take measures against lightning strikes in the system.
- Prevent foreign matter such as dust or wire debris from getting inside the product.
- Mount the product in a place that is not exposed to excessive vibration or impact.
Otherwise failure or malfunction can result.
- Do not use the product in an environment that is exposed to temperature cycle.
Heat cycles other than ordinary changes in temperature can adversely affect the inside of the product.
- Do not expose the product to direct sunlight.
If using in a location directly exposed to sunlight, shade the product from the sunlight.
Otherwise failure or malfunction can result.
- Keep within the specified ambient temperature range.
Otherwise malfunction can result.
- Do not operate close to a heat source, or in a location exposed to radiant heat.
Otherwise malfunction can result.

*Adjustment and Operation

- Set the switches by using a sharp-pointed screwdriver etc. When setting the switch, do not touch other unrelated parts.
This can cause parts damage or malfunction due to a short circuit.
- Perform settings suitable for the operating conditions.
Incorrect setting can cause operation failure.
- Please refer to the PLC manufacturer's manual etc. for details of programming and addresses.
For the PLC protocol and programming refer to the relevant manufacturer's documentation.

*Maintenance

- Turn off the power supply, stop the supplied air, exhaust the residual pressure and verify the release of air before performing maintenance.
There is a risk of unexpected malfunction.
- Perform regular maintenance and inspections.
There is a risk of unexpected malfunction.
- After maintenance is complete, perform appropriate functional inspections.
Stop operation if the equipment does not function properly.
Otherwise safety is not assured due to an unexpected malfunction or incorrect operation.
- Do not use solvents such as benzene, thinner etc. to clean each unit.
They could damage the surface of the body and erase the markings on the body.
Use a soft cloth to remove stains.
For heavy stains, use a cloth soaked with diluted neutral detergent and fully squeezed, then wipe up the stains again with a dry cloth.

System Outline

•System configuration

The EX600 range of units can be connected to various types of Fieldbus to realize the reduction of input or output device wiring and the distributed control system. The unit communicates with the Fieldbus through the SI unit. One SI unit can be connected with manifold valves with up to 32 points and the input • output • I/O units with maximum 10 points.

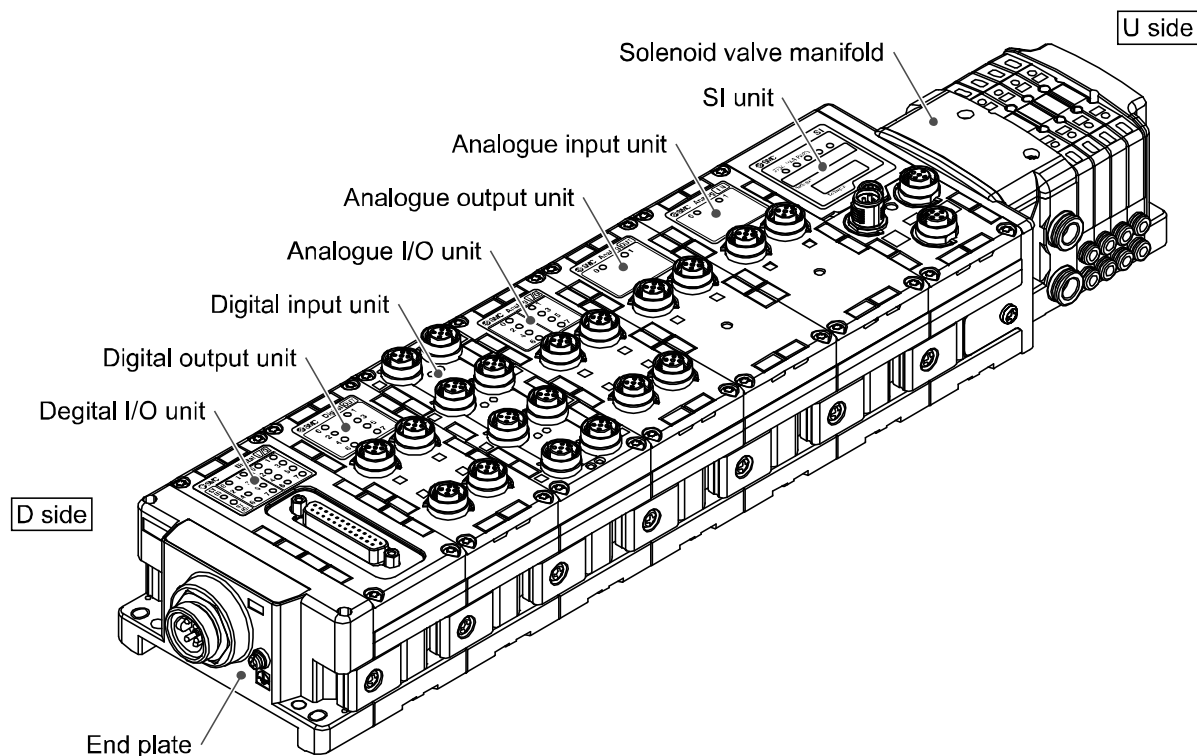

SI unit: Performs Fieldbus communication and solenoid valve manifold ON/OFF output.

Digital input unit: For connecting sensors with switch output capability. PNP and NPN types are available.

Digital output unit: For connecting output device such as solenoid valves, lamps, buzzers, etc.
PNP and NPN types are available.

Digital I/O unit: This unit has both digital input and output functions. PNP and NPN types are available.

Analogue input unit: For connecting sensors with analogue output capability.

Analogue output unit: This can be connected to the equipment which can read analogue input.

Analogue I/O unit: This unit has both analogue input and output functions.

End plate: Connected at EX600 Manifold's D side, incorporating the power supply connection.

Solenoid valve manifold: An assembly of solenoid valves.

One connector is used as the electric connection to all connected valves.

■ Definition and terminology

	Terminology	Definition
A	Address (Station Address)	A number assigned to identify the unit connected onto the PROFIBUS DP network. It must not be duplicated.
	AD value	The signal from the analogue input device is converted to digital, and displayed in decimal and hexadecimal. These hexadecimal and decimal values are also outputted to the analogue output device.
C	Communication speed	The speed at which the fieldbus sends and receives data. It depends on higher-level equipment (PLC, etc.) and is measured in bps (bits per second).
	Current consumption	The current necessary to operate each unit.
D	Diagnosis Information	Consists of the standard diagnosis information defined by PROFIBUS DP and the diagnosis information unique to the product.
	DIN rail	A metal rail conforming with DIN (German) standard.
	D Side	The side connected to the end plate when the product is connected to a manifold.
E	Enclosure (IP□□)	Abbreviation of international (ingress) protection. A standard related to the protection from external objects (hands, steel ball, steel wire, dust, water, etc.) applied to the product.
F	FAIL SAFE Function	Sends the communication frame including the output data with a 0 data length when the PLC (master) has come to clear mode. This sets the product to a defined status (HOLD/CLEAR/Forced on).
	FE	Abbreviation of functional earth.
	Fieldbus	The protocol that uses digital communication to exchange signals between field equipment (instruments and actuators) running on site and a PLC.
	FREEZE Function	A function to synchronize the input data of the SI unit with the FREEZE command from the PLC (master).
G	GSD file	The file to which the master data of the product is written.
H	Handheld Terminal (H.T.)	Connected to the dedicated connector of the SI unit to adjust the internal parameters, monitor the status of all input and output signals, and turn on input and output forcedly.
I	Idling	A status in which the SI unit has received the FAIL SAFE command. The output can be cleared, held or forcedly switched on by setting parameters.
	ID No.	A 16 bit number assigned by the PNO to identify the product.
M	Manifold	A form consisting of multiple components. A form made by combining multiple components
N	NPN input	Takes the sensor output that uses the NPN transistor to the signal output line.
	NPN output	The output type that uses an NPN transistor to operate output device. It is also known as a positive common type since a positive potential is applied to the power supply line.
	Number of inputs	The number of points that can receive information from input device (sensor, switch, etc.).
	Number of outputs	The number of points that can operate output device (solenoid valve, light, motor, etc.).
O	Open circuit detection	A diagnosis function to detect if the input or output device wiring is disconnected.

	Terminology	Definition
P	PLC	Abbreviation of programmable logic controller. A digital computer used for automation of electromechanical processes.
	PNP input	Takes the sensor output that uses the PNP transistor to the signal output part.
	PNP output	The output type that uses a PNP transistor to operate output device. It is also known as a negative common type since a negative potential is applied to the power supply line.
S	Short circuit detection	A diagnosis function to detect an over current due to the short circuit of the output and/or power supply positive line with respect to the GND line.
	Short circuit protection	A function to protect the internal circuit from being broken by an over current due to the short circuit of the output and/or power supply positive line with respect to the GND line.
	SI unit	Abbreviation of serial interface unit. A unit connected to a PLC to communicate input and output data.
	SYNC Function	A function to synchronize the output data of the SI unit with the SYNC command from the master.
T	Terminal resistor	A resistor mounted at either end of the fieldbus network.
U	U Side	The side connected to the solenoid valve when the product is connected to a manifold.

Assembly

•Composing the unit as a manifold

*: If the unit was purchased as a manifold, the work described in this section is not necessary.

(1) Connect the unit to the end plate.

The Digital unit, Analogue unit can be connected in any order.

Tighten the bracket of the joint using tightening torque 1.5 to 1.6 N·m.

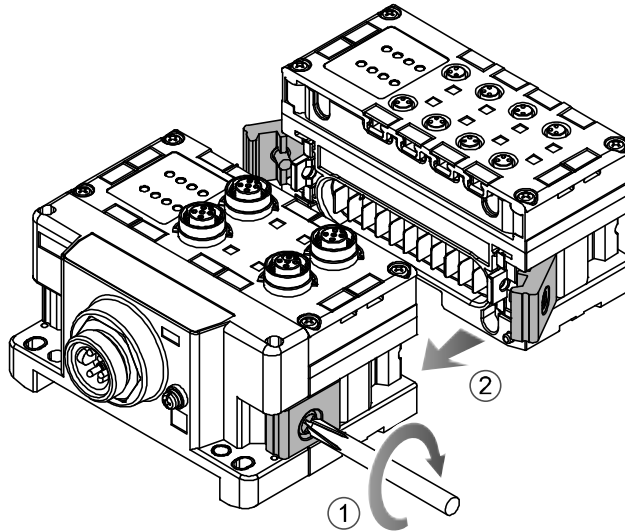

(2) Add more units.

Up to 10 units (including the SI unit) can be connected to one manifold.

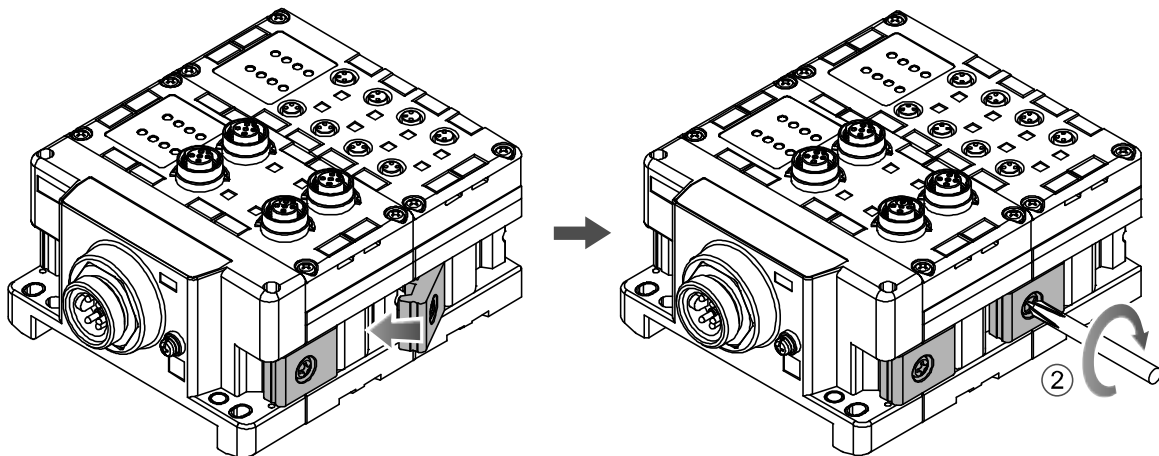

(3) Connecting the SI unit.

After connecting the necessary units, connect the SI unit.

Connecting method is the same as above (1), (2).

(4) Mounting the valve plate.

Mount the valve plate (EX600-ZMV#) to the valve manifold using the valve set screws. (M3 x 8)
Apply 0.6 to 0.7 N•m tightening torque to the screws.

Screw mounting place

SV	: 2 places
S0700	: 2 places
VQC1000	: 2 places
VQC2000	: 3 places
VQC4000	: 4 places
SY	: 2 places
JSY	: 2 places

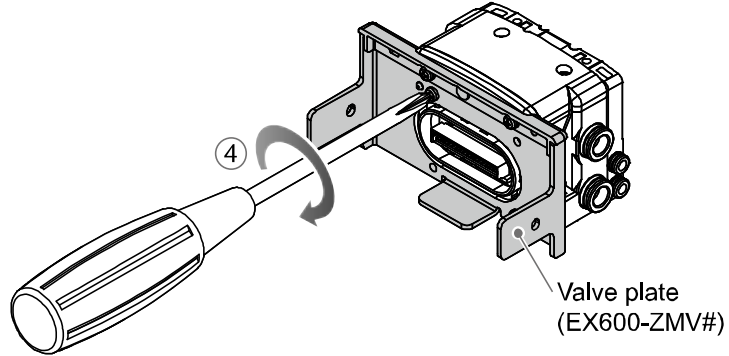

(5) Connect the SI unit and the valve manifold.

Insert the valve plate to the valve plate set groove on the side of SI unit.
Then, tighten it with the valve plate set screws (M4 x 6) to fix the plate.
Tightening torque for set screws 0.7 to 0.8 N•m.

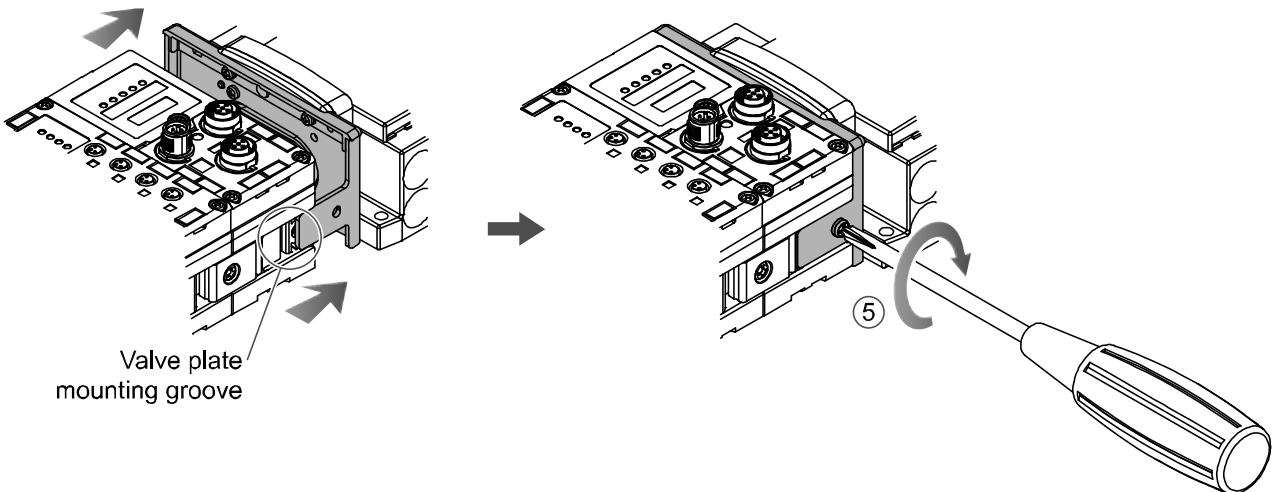

● Precautions for handling

- Please do not connect the unit while the power supply is active. It will cause equipment damage.
- Take care not to drop the nuts of Joint bracket.
- Tighten the screws securely using the specified torque.
The product may not operate properly if the screws are loose.

Mounting and Installation

■ Installation

• Direct mounting

- (1) When joining six or more units, fix the middle part of the complete EX600 unit with an intermediate reinforcing brace (EX600-ZMB1) before mounting using 2-M4 x 5 screws.

Tightening torque: 0.7 to 0.8 N•m.

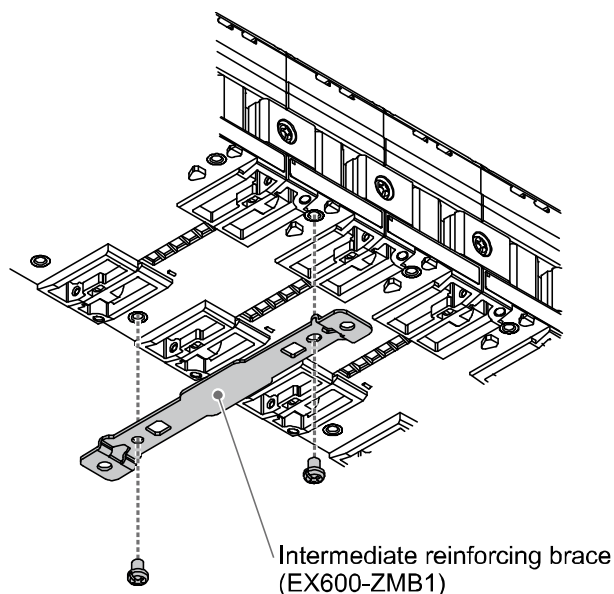

- (2) Fix and tighten the end plates at one end of the unit. (M4)

Tightening torque: 0.7 to 0.8 N•m.

Fix the end plate at the valve side while referring to the operation manual of the corresponding valve manifold.

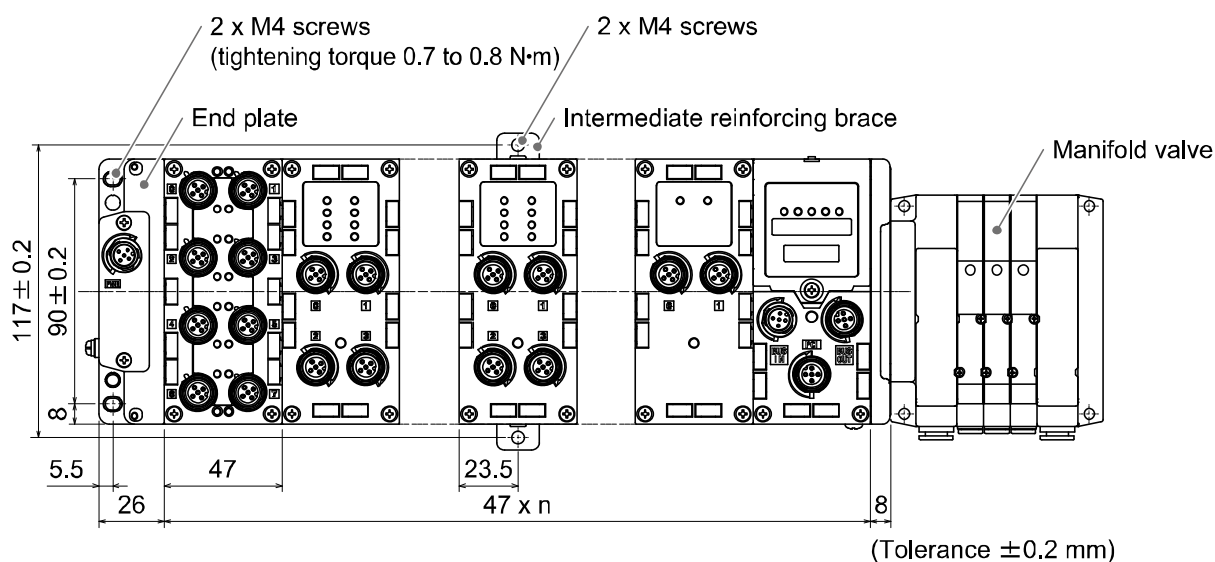

n (Number of connected units) ≤ 10

● Precautions for handling

- When joining six or more units, fix the middle part of the units with an intermediate reinforcing brace to prevent connection failure between the units due to deflection.

•DIN rail mounting

(Available for series other than SY series. Refer to the catalog for SY series.)

- (1) When joining six or more units, fix the middle part of the complete EX600 unit with an intermediate reinforcing brace (EX600-ZMB2) before mounting, using 2-M4 x 6 screws.
Tightening torque: 0.7 to 0.8 N•m.
- (2) Mount the end plate bracket (EX600-ZMA2) to the end plate at the opposite end to the valves, using 2-M4 x 14 screws.
Tightening torque: 0.7 to 0.8 N•m.

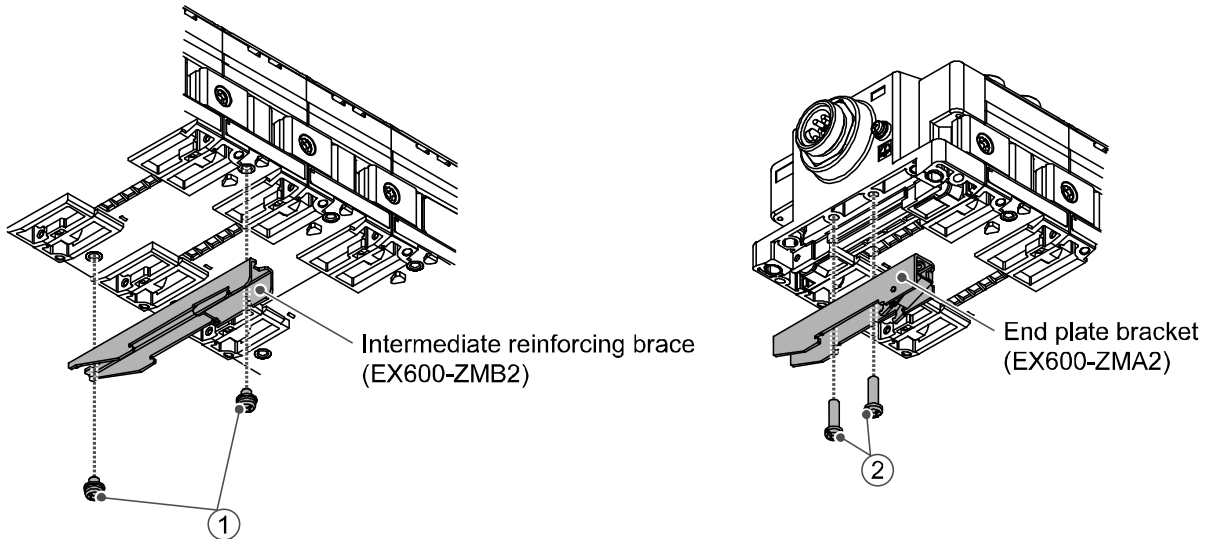

- (3) Hook the DIN rail mounting groove to the DIN rail.
- (4) Press the manifold using its side hooked to the DIN rail as a fulcrum until the manifold is locked.
- (5) Fix the manifold by tightening the DIN rail fixing screws of the EX600-ZMA2. (M4 x 20)
Tightening torque: 0.7 to 0.8 N•m.
The tightening torque at the valve side depends on the valve type.
Refer to the operation manual of the corresponding valve manifold.

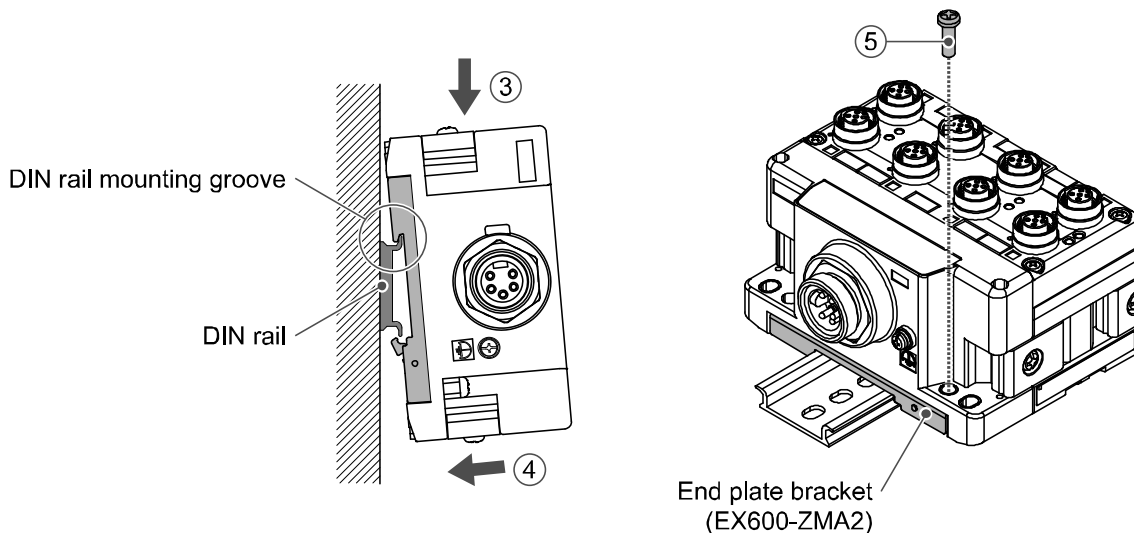

•Precautions for handling

- When joining six or more units, fix the middle part of the units with an intermediate reinforcing brace to prevent connection failure between the units due to deflection.

■Wiring

•Connect the M12 or M8 connector cable. M12 connector is applicable for SPEEDCON connector. SPEEDCON connector wiring method is explained below.

(1) Align the mark B on the metal bracket of the cable side connector (plug/socket) with the mark A.

(2) Align the mark C on the unit and insert the connector into the unit vertically.

If they are not aligned, the connector cannot be joined properly.

(3) When the mark B of the connector has been turned 180 degrees, wiring is completed. Confirm that the connection is not loose. If turned too far, it will become hard to remove the connector.

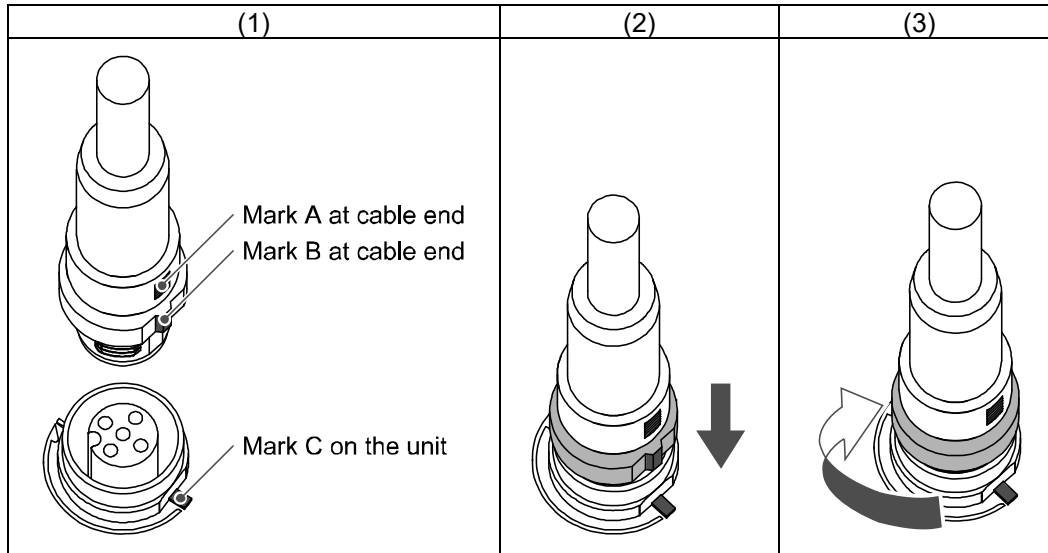

•Mounting the marker

Signal name of the input or output devices and unit address can be written to the marker, and it can be installed to each unit.

Mount the marker (EX600-ZT1) into the marker groove as required.

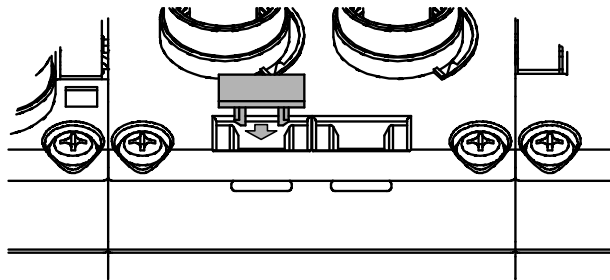

SI unit

Model Indication and How to Order

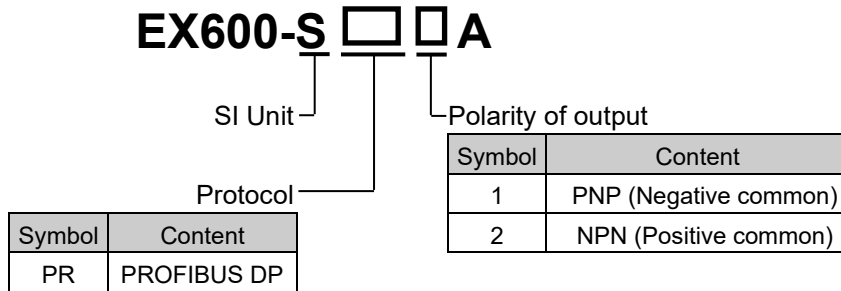

Summary of Product parts

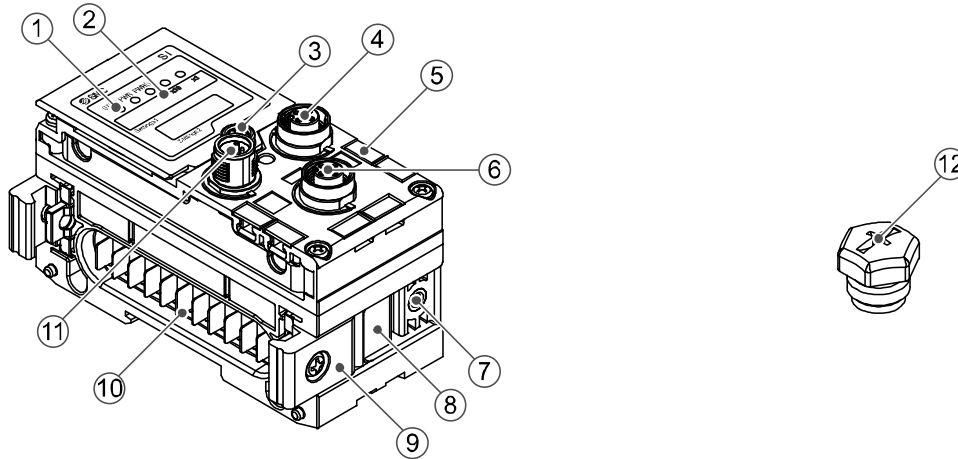

No.	Description	Function
1	Status display LED	Displays the status of the unit.
2	Display cover	Open for the setting of switch.
3	Display cover tightening screw	Loosen to open the display cover.
4	Connector (BUS OUT)	Connects the cable for fieldbus outputs.
5	Marker groove	Groove to mount a marker.
6	Connector (PCI)	Connects the cable of the handheld terminal.
7	Valve plate mounting screw hole	Fixes the valve plate.
8	Valve plate mounting groove	Groove to insert the valve plate into.
9	Joint bracket	Bracket for joining to adjacent units.
10	Unit connector (plug)	Transmits signals and power supplies to adjacent units.
11	Connector (BUS IN)	Connects the cable for fieldbus inputs.
12	Seal cap (2 pcs.)	Mounted on to unused connectors (BUS OUT and PCI).

Mounting and Installation

■Wiring

○Connector pin assignment and circuit diagram

•Connector pin assignment

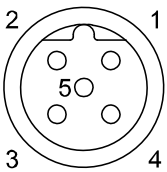
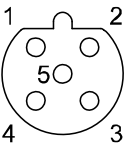
Configuration		Pin No.	Signal name
BUS IN	BUS OUT		
		1	NC
		2	RXD/TXD-N
		3	NC
		4	RXD/TXD-P
		5	Shield

•Circuit diagram

The product has T branching internally in the unit as shown in the circuit diagram below. It can be extended by connecting the PROFIBUS DP slave with BUS OUT.

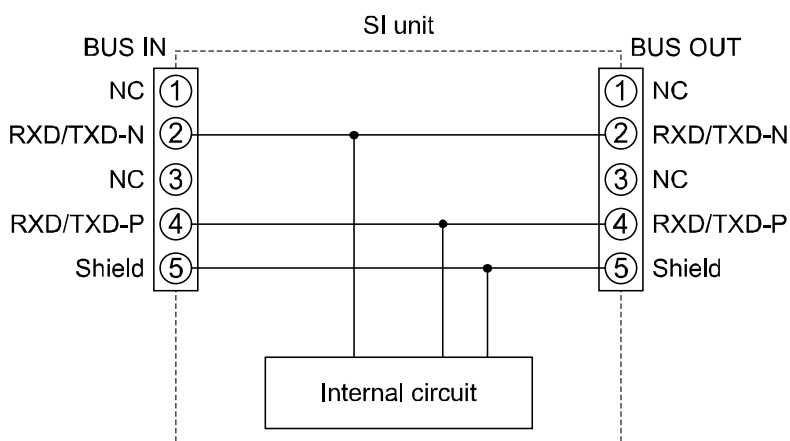

●Precautions for handling

Be sure to fit a seal cap on any unused connectors. Proper use of the seal cap enables the enclosure to achieve IP67 specification.

•Transmission distance

The communication wire shall be a PROFIBUS DP compliant shielded twisted pair cable. The maximum cable length depends on the transmission speed and the cable type. The table below shows the values when type A cable is used.

Communication speed [kbps]	9.6	19.2	45.45	93.75	187.5	500	1500	3000	6000	12000
Cable length [m]	1200	1000	400	200	100					

Setting and Adjustment

•Switch setting

- (1) Loosen the display cover screw (indicated by arrow).
- (2) Open the display cover using a flat head screwdriver, etc.

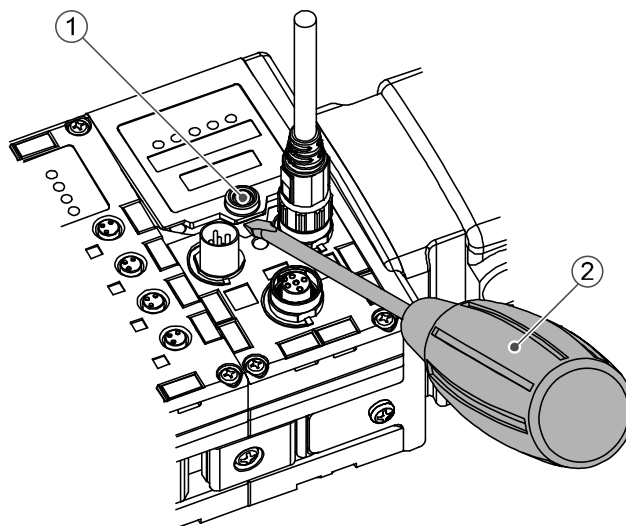

- (3) Set the switch using a small watchmaker's screwdriver with a thin blade, referring to the setting of switch on the following pages.
- (4) After setting the switch, tighten the display cover tightening screw in the reverse order of the above procedure. (Tightening torque: 0.3 to 0.4 N•m)

•Precautions for handling

- Turn off the power supply whilst setting the switch.
- If there is foreign matter or water droplets around the display cover, clean it off before opening the cover.
- When setting the switch, do not touch other unrelated parts. This can cause parts damage or malfunction due to a short circuit.
- All default settings are off or 0. Perform the setting of the switch before using this product.
- The switch setting will become valid when the power supply is turned ON.

•Address setting switch: Set the PROFIBUS DP node address.

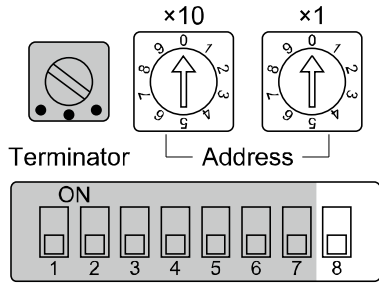

Settings1

Address setting switch (x10): Sets the 10 digit of the PROFIBUS DP node address.

Address setting switch (x1): Sets the 1 digit of the PROFIBUS DP node address.

Settings1 switch (8): Sets the 3rd digit of the PROFIBUS DP node address.

Address Setting

Setting1	Address		Node Address
	x10	x1	
OFF	0	0	0 (Default setting)
	0	1	1
	0	2	2
	:	:	:
	9	8	98
	9	9	99
ON	0	0	100
	0	1	101
	:	:	:
	2	5	125

*: When the address is set to 0, or to 126 or over, it causes an error and turns on the [SF] and [BF] LED's.

- V_SEL switch: A function to select the number of occupied valve outputs.
The number of outputs (size) occupied by the SI unit is selected.

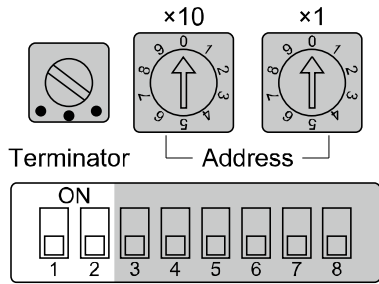

Settings1

Settings1		Content	SI unit output data size
1	2		
OFF	OFF	Number of occupied valve 32 outputs	4 byte (Default setting)
OFF	ON	Number of occupied valve 24 outputs	3 byte
ON	OFF	Number of occupied valve 16 outputs	2 byte
ON	ON	Number of occupied valve 8 outputs	1 byte

*: Set the number of occupied valve outputs to at least the number of valves used.

- HOLD/CLEAR switch: Sets the output status when the Fieldbus has a communication error or is in idling state.

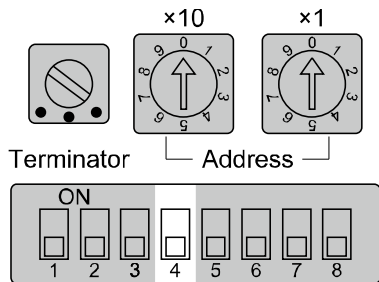

Settings1

Settings1		Content
4		
OFF		Output is Off. (Default setting)
ON		Holds the output.

*: This switch can be enabled and disabled by parameter.

•Terminator switch: Sets the terminal resistor of the PROFIBUS DP communication line.

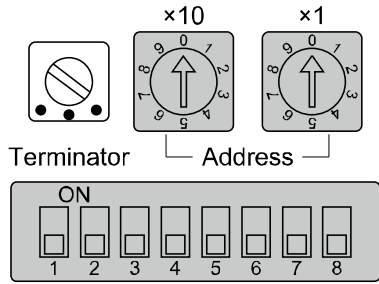

Settings1

Setting of the terminal resistor		
Terminal resistor ON	Terminal resistor OFF (Default setting)	Terminal resistor OFF

•Precautions for handling

- When the product is connected to at the end of the PROFIBUS communication line, be sure to set it to "Terminal resistor ON".
- The terminal resistance depends on the specifications of the cable. The terminal resistance is of the type A cable.
- Handle the switch with care Excessive force can break the switch.
- Switches of 3, 5, 6 and 7 on the Settings1 switch are not used. (Do not turn ON)
- When Settings 1 switch No. 7 is turned ON, the LED of the product will turn OFF. Make sure that the switch is turned OFF.





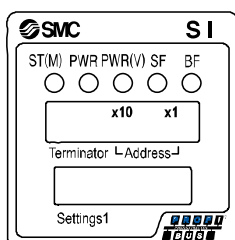

LED Display

The status display LED displays the power supply and communication status.
Various kinds of status can be checked as follows:





Display	Content
ST(M)	Displays the diagnosis status of the unit.
PWR	Displays the status of the power supply voltage for control and input.
PWR(V)	Displays the status of the power supply voltage for outputs.
SF	Displays system fault.
BF	Displays bus fault.

•ST(M)-LED

LED display	Content
ST(M)  OFF	The power supply for control and input is OFF.
ST(M)  Green LED is ON	The unit is in normal operation.
ST(M)  Green LED is flashing	Detected diagnostic error of I/O unit.
ST(M)  Red LED is flashing	Detected either of the diagnostic errors below (When diagnostics is activated) <ul style="list-style-type: none"> •The valve ON/OFF counter has exceeded the set value. •The valve is short circuited or disconnected.
ST(M)  Red/green LED is flashing alternately	Detected a communication error between SI unit and I/O unit.
ST(M)  Red LED is ON	SI unit has failed.



*: Refer to "Troubleshooting" (page 44), for the further details of countermeasures.

•PWR-LED

LED Display	Contents
PWR  Green LED is ON	The power supply voltage level for control and input is normal.
PWR  Red LED is ON	The power supply voltage level for control and input is abnormal. (When diagnostics is activated)







*: Refer to "Troubleshooting" (page 44), for the further details of countermeasures.

•PWR(V)-LED

LED Display	Contents
PWR(V)  OFF	Power supply voltage for output is OFF or the voltage level is abnormal. (When diagnostics is not activated)
PWR(V)  Green LED is ON	The power supply voltage level for output is normal.
PWR(V)  Red LED is ON	Power supply voltage for output is OFF or the voltage level is abnormal. (When diagnostics is activated)

*: Refer to "Troubleshooting" (page 44), for the further details of countermeasures.

•SF-LED or BF-LED

LED Display	Contents
SF BF  OFF	Either of the following conditions: <ul style="list-style-type: none"> •Communication with the master is established and normal. •The power supply for control and input is OFF.
SF BF  Red SF LED is ON	The communication with the master has been established, but a diagnosis error has occurred.
SF BF  Red BF LED is ON	Either of the following conditions: <ul style="list-style-type: none"> •The cable between the master and SI unit is not connected. •SI unit is not receiving the master data correctly. •The master or the SI unit has broken.
SF BF  Red BF and SF LEDs are both ON	The address of the SI unit is set to 0, or to 126 or over.
SF BF  Red SF LED is ON and red BF LED is flashing	The configuration data of the master and device are not consistent.
SF BF  Red BF LED is flashing	One second flashing cycle: SI unit is recognizing the communication speed but the master address setting is wrong. Two seconds flashing cycle: The power source of PLC is OFF or the cable has a broken wire.

*: Refer to "Troubleshooting" (page 44), for the further details of countermeasures.

Specifications

Model		EX600-SPR1A	EX600-SPR2A
Communication	Fieldbus	PROFIBUS DP (DP-V0)	
	Device type	PROFIBUS DP	
	Communication speed	9.6/19.2/45.45/93.75/187.5/500 kbps 1.5/3/6/12 Mbps	
	Configuration file	GSD (SMCB1411.gsd)	
	Occupied area (Number of inputs/outputs)	(512 inputs/512 outputs) max.	
Power supply (control and input)		24 VDC Class 2, 2 A	
Terminal resistor		Internally implemented (For type A cable)	
Internal current consumption (The power supply for control and input)		80 mA or less	
Valve output	Polarity of output	Source/PNP (Negative common)	Sink/NPN (Positive common)
	Output channel	32 outputs (8/16/24/32 outputs selectable)	
	Connected load	Solenoid valve with circuit of protection of surge voltage of 24 VDC 1.5 W (SMC)	
	Power supply (output)	24 VDC Class2, 2 A	
	Output for com. error	HOLD/CLEAR/Force ON	
	Protective function	Short circuit protection	
Environment	Enclosure	IP67 (with manifold assembled) *1	
	Operating temperature range	-10 to 50 °C	
	Storage temperature range	-20 to 60 °C	
	Operating humidity range	35 to 85%RH (no condensation)	
	Withstand voltage	500 VAC for 1 minute between external terminals and FE	
Insulation resistance	500 VDC, 10 MΩ or more between external terminals and FE		
Standard		CE/UKCA marked, UL (CSA)	
Weight		300 g	

*1: All unused connectors must have the seal cap fitted.

•PROFIBUS DP function

Model number	EX600-SPR1A	EX600-SPR2A
Address setting range	1 to 125	
FREEZE function	Supported	
SYNC function	Supported	
FAIL SAFE function	Supported	
ID number	1411 (Hex)	

■Dimensions

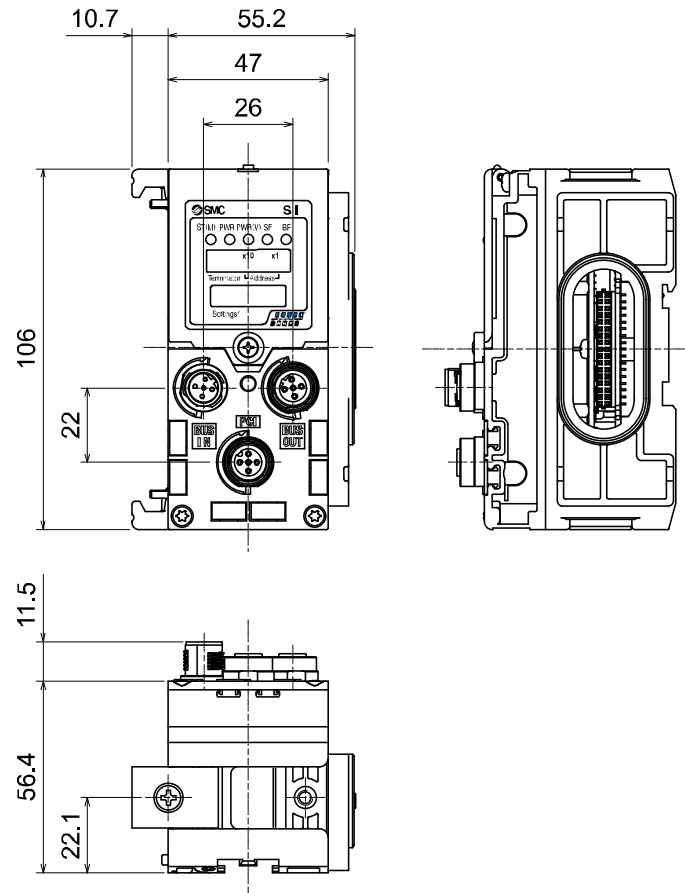

End plate

Model Indication and How to Order

EX600-ED□-□

End plate at D side

Mounting method

Connector

Symbol	Connector	Key type	Function
2	M12 (5-pin)	B-coded	IN
3	7/8 inch (5-pin)	-	IN
4	M12 (4-pin/5-pin)	A-coded	IN/OUT (PIN layout 1*)
5	M12 (4-pin/5-pin)	A-coded	IN/OUT (PIN layout 2)

Symbol	Description
Nil	No DIN rail bracket
2	With DIN rail bracket (VQC/SV/S0700 valve)
3	With DIN rail bracket (SY/JSY valve)

*: Refer to Connector Pin No. (page 30) for details of the PIN layout 1 and 2.

EX600-EU1-□

End plate at U side

Mounting method

Symbol	Description
Nil	No DIN rail bracket
2	With DIN rail bracket (EX600-ED#-2)
3	With DIN rail bracket (EX600-ED#-3)

Summary of Product parts

•EX600-ED2-#

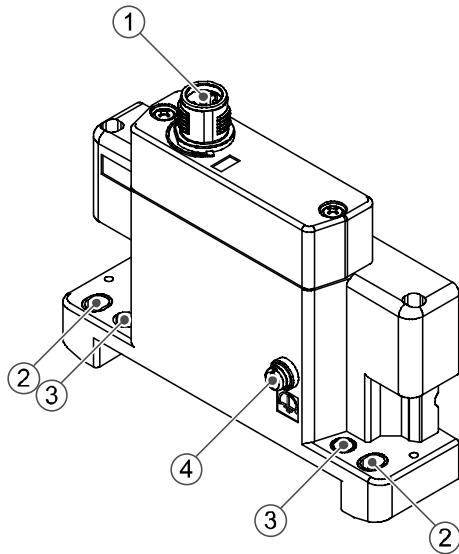

•EX600-ED3-#

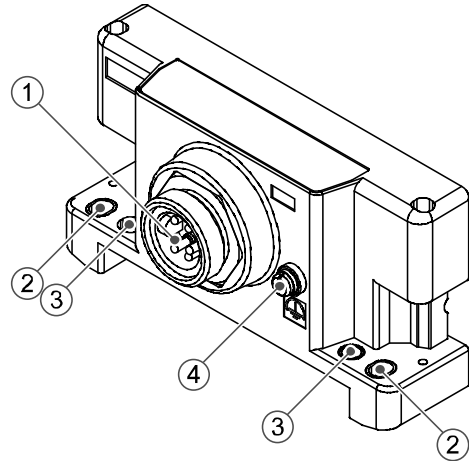

•EX600-EU1-#

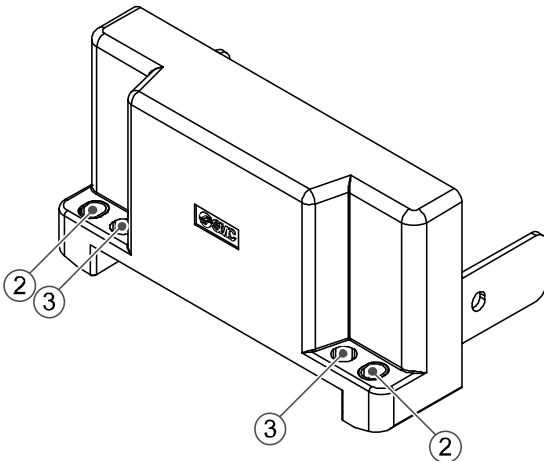

No.	Description	Function
1	Power connector	Connector for power supply to SI unit and I/O unit.
2	Fixing hole for direct mounting	Holes for direct mounting.
3	DIN rail fixing hole	Holes for fix DIN rail mounting.
4	F.E. terminal *	Functional Earth terminal - must be connected directly to system earth (ground).

*: Individual grounding should be provided close to the product with a short cable.

•EX600-ED4/ED5-#

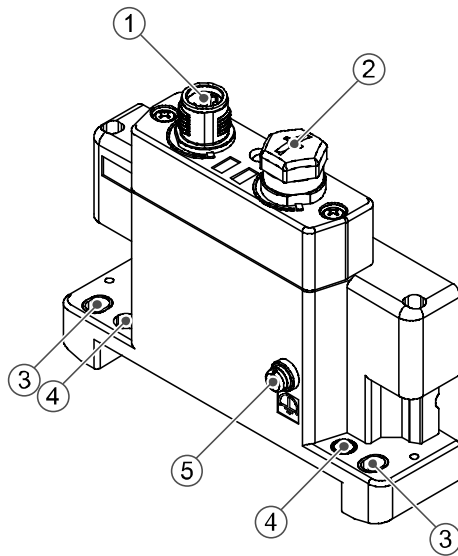

No.	Description	Function
1	Power connector (PWR IN)	Supplies power for each unit and input/output devices.
2	Power connector (PWR OUT)	Provides power to downstream equipment.
3	Fixing hole for direct mounting	Holes used for direct mounting.
4	DIN rail fixing hole	Holes used for fix DIN rail.
5	F.E. terminal *	Functional Earth terminal - must be connected directly to system earth (ground).

*: Individual grounding should be provided close to the product with a short cable.

Mounting and Installation

■Wiring

○Connector pin assignment

(1) EX600-ED2-#

PWR IN: M12 5-pin Plug B-coded

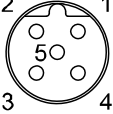
Configuration	Pin No.	Signal name
	1	24 V (Output)
	2	0 V (Output)
	3	24 V (Control and input)
	4	0 V (Control and input)
	5	F.E.

(2) EX600-ED3-#

PWR IN: 7/8 inch 5-pin Plug

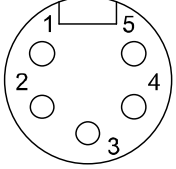
Configuration	Pin No.	Signal name
	1	0 V (Output)
	2	0 V (Control and input)
	3	F.E.
	4	24 V (Control and input)
	5	24 V (Output)

(3) EX600-ED4-#

PWR IN: M12 4-pin Plug A-coded

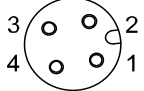
Configuration	Pin No.	Signal name
	1	24 V (Control and input)
	2	24 V (Output)
	3	0 V (Control and input)
	4	0 V (Output)

PWR OUT: M12 5-pin Socket A-coded

Configuration	Pin No.	Signal name
	1	24 V (Control and input)
	2	24 V (Output)
	3	0 V (Control and input)
	4	0 V (Output)
	5	Not used

(4) EX600-ED5-#

PWR IN: M12 4-pin Plug A-coded

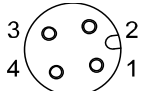
Configuration	Pin No.	Signal name
	1	24 V (Output)
	2	0 V (Output)
	3	24 V (Control and input)
	4	0 V (Control and input)

PWR OUT: M12 5-pin Socket A-coded

Configuration	Pin No.	Signal name
	1	24 V (Output)
	2	0 V (Output)
	3	24 V (Control and input)
	4	0 V (Control and input)
	5	Not used

○Regarding the 2 types of power supply

The power supply consists of two power supply systems as follows:

- Power supply for control and input: Supplying power for control of each unit's power supply for control and also for device connected to input port of Digital and Analogue unit.
- Power supply for output: Supplying power for equipment connected to output port of Digital and Analogue unit, and also power supply for solenoid valve manifold.

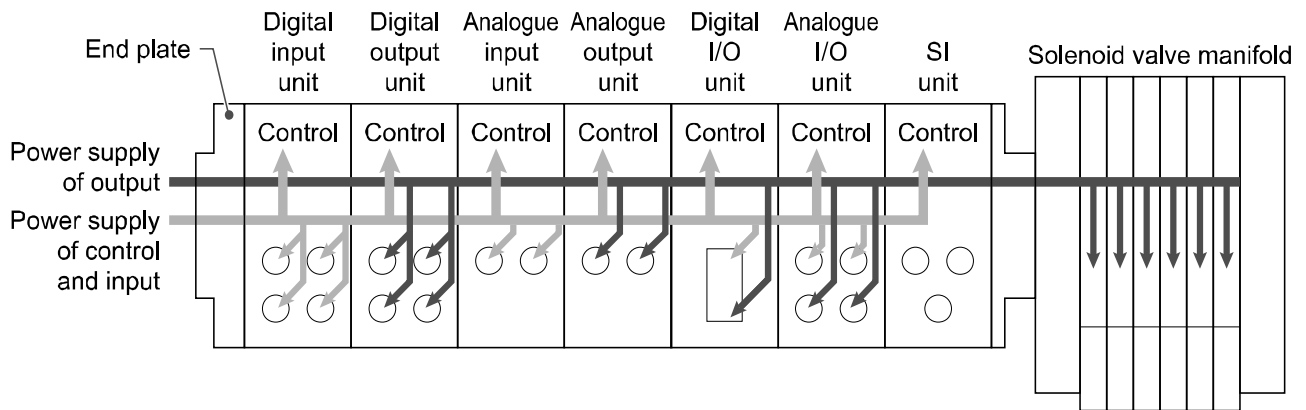

●Precautions for handling

Be sure to fit a seal cap on any unused connectors. Proper use of the seal cap enables the enclosure to achieve IP67 specification.

Specifications

Model		EX600-ED2-#	EX600-ED3-#	EX600-ED4-#	EX600-ED5-#	
Power	Power connector	PWR IN	M12 (5-pin) Plug	7/8 inch (5-pin) Plug	M12 (4-pin) Plug	M12 (4-pin) Plug
		PWR OUT	-	-	M12 (5-pin) Socket	M12 (5-pin) Socket
	Power supply (Control and input)		24 VDC \pm 10%, 2 A	24 VDC \pm 10%, 8 A	DC24 V \pm 10%, 4 A	
	Power supply (Output)		24 VDC +10/-5%, 2 A	24 VDC +10/-5%, 8 A	DC24 V +10/-5%, 4 A	
Environment	Enclosure		IP67 (With manifold assembled) *1			
	Operating temperature range		-10 to 50 °C			
	Storage temperature range		-20 to 60 °C			
	Operating humidity range		35 to 85%R.H. (No condensation)			
	Withstand voltage		500 VAC for 1 minute between external terminals and F.E.			
	Insulation resistance		500 VDC, 10 M Ω min. between external terminals and F.E.			
Standard		UL/CSA(E209424) CE/UKCA marked		CE/UKCA marked		
Weight		170 g	175 g	170 g		

*1: All unused connectors must have a seal cap fitted.

■Dimensions

•EX600-ED2

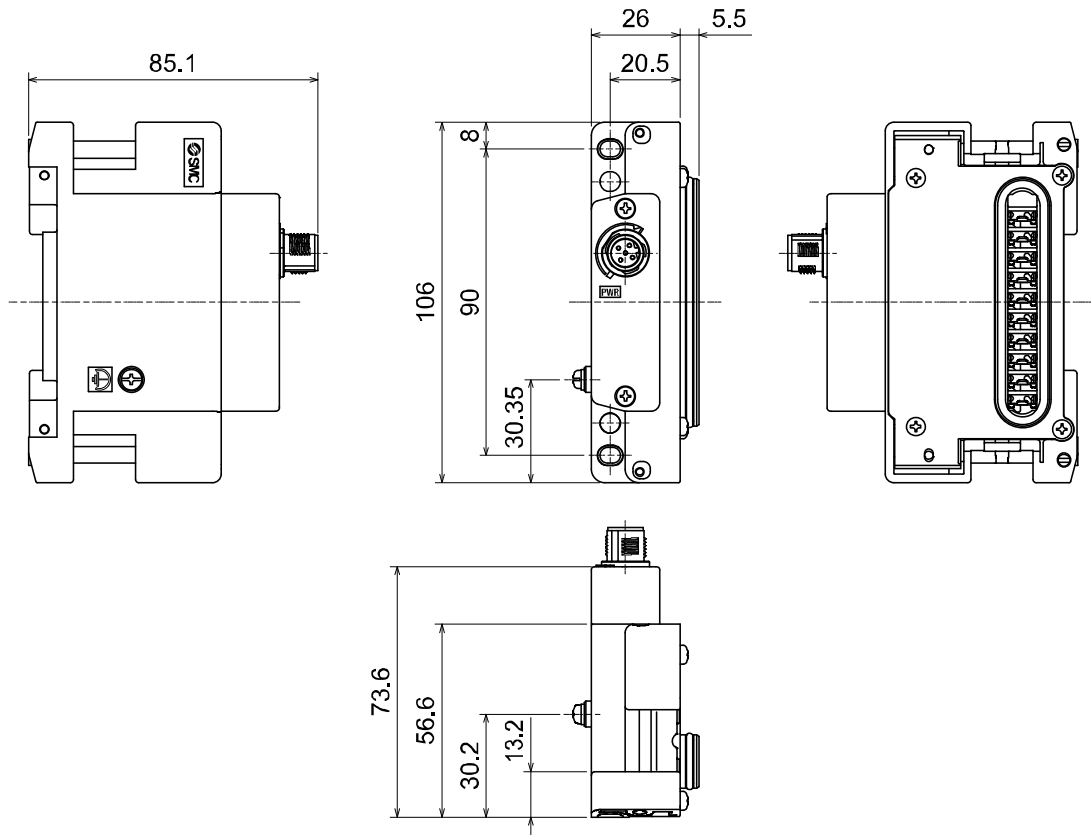

•EX600-ED2-2

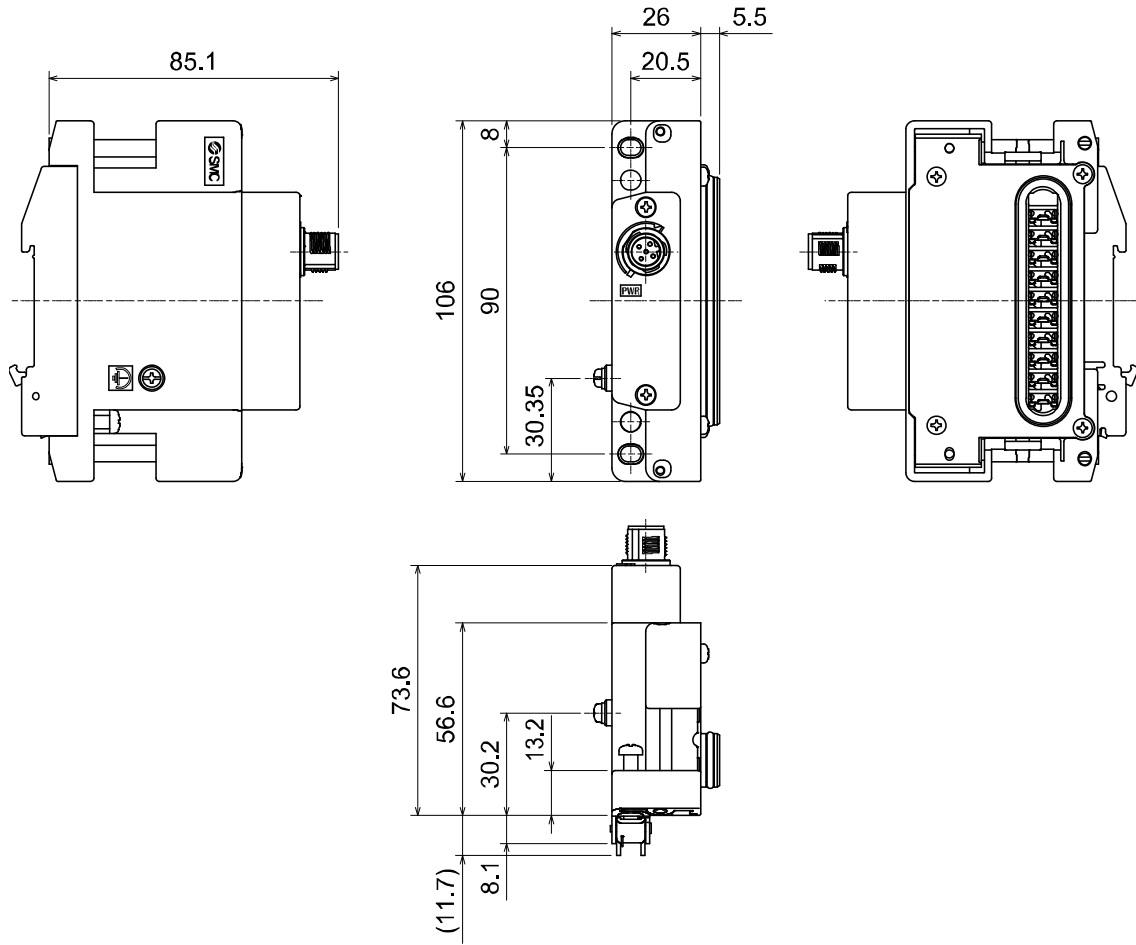

•EX600-ED2-3

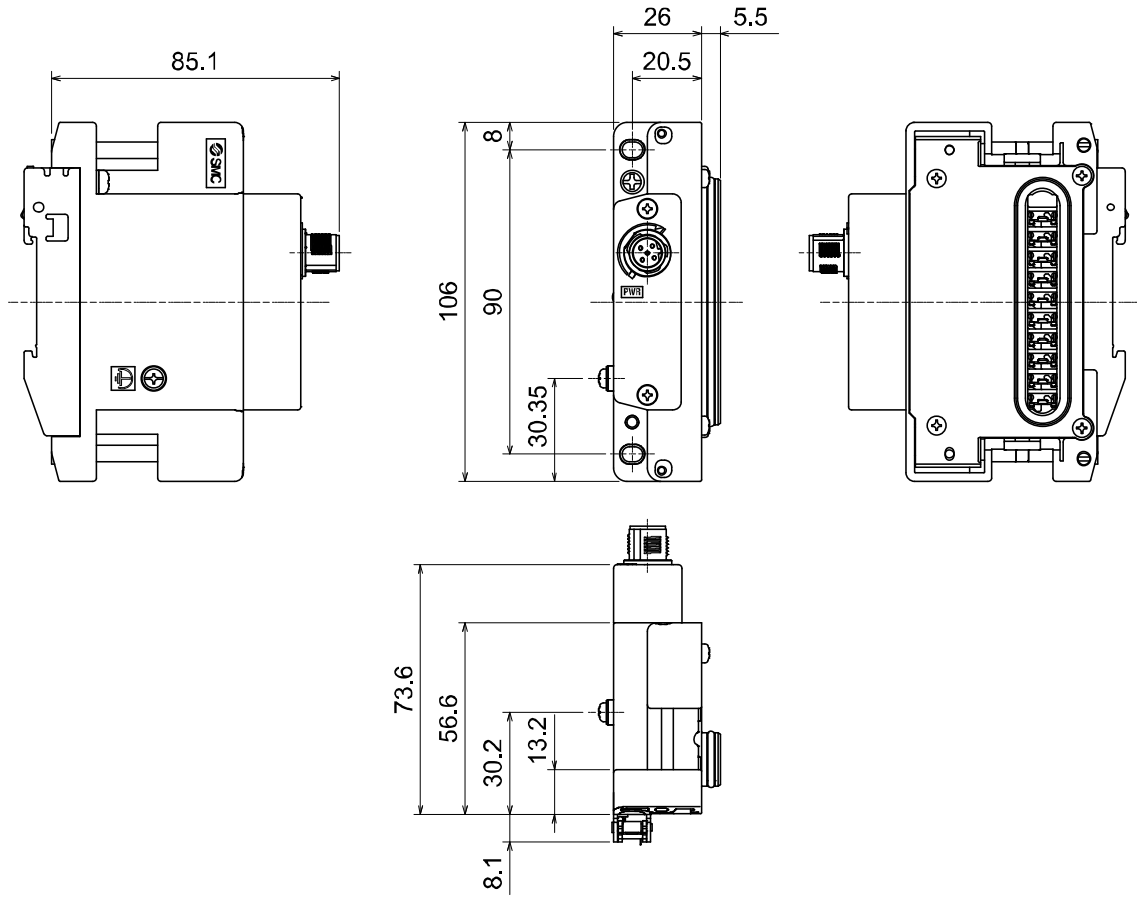

•EX600-ED3

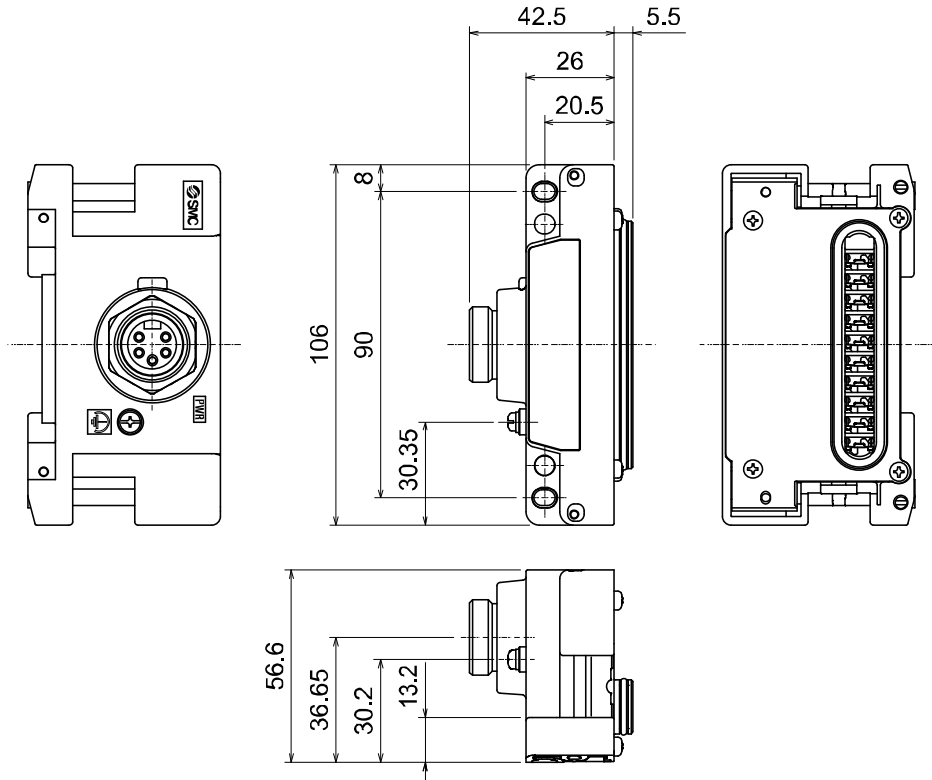

•EX600-ED3-2

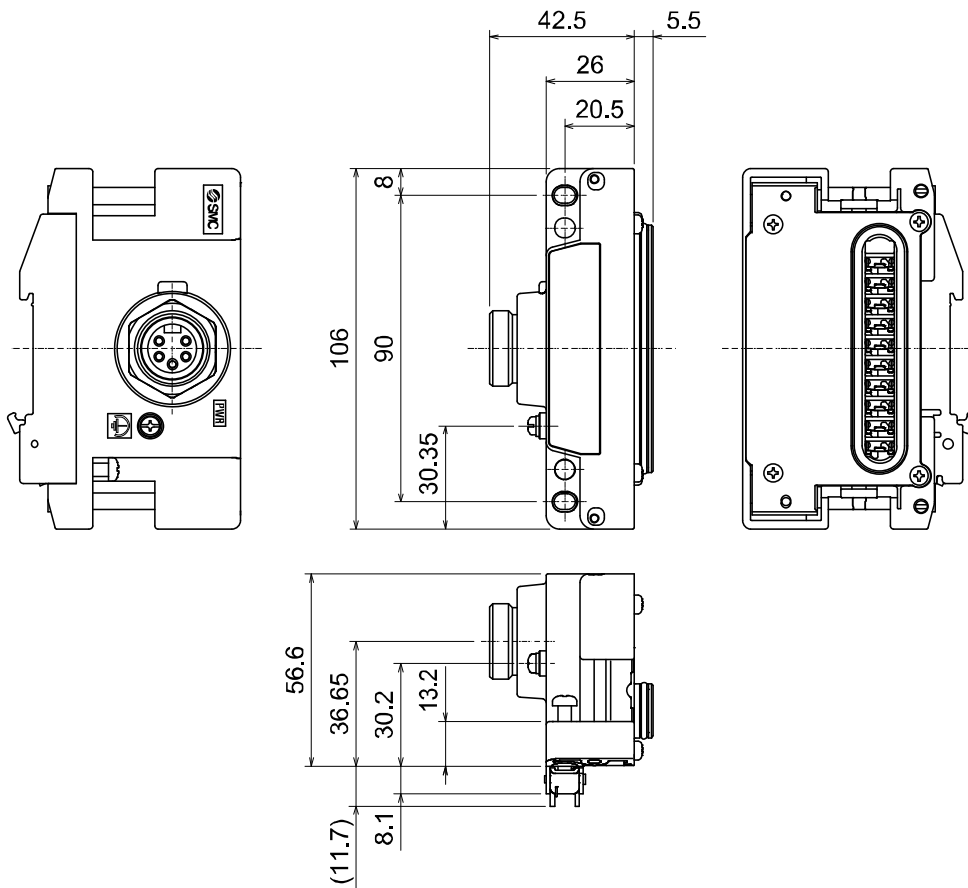

•EX600-ED3-3

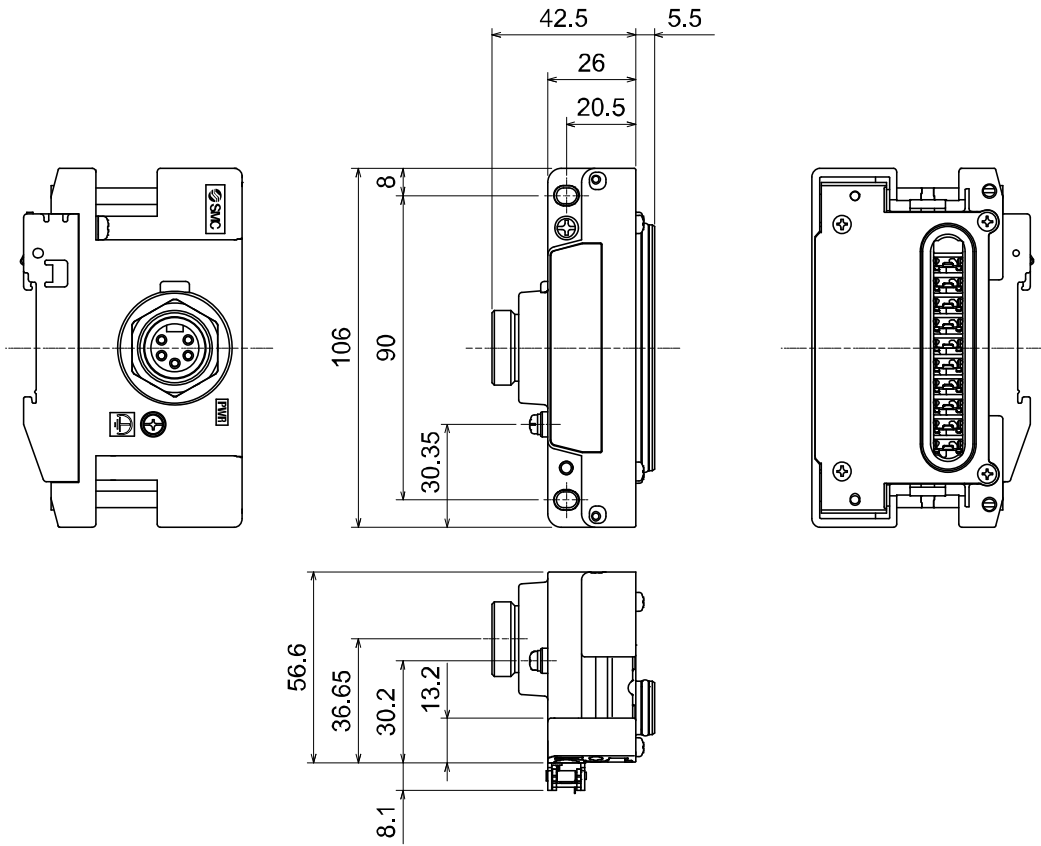

•EX600-ED4/ED5

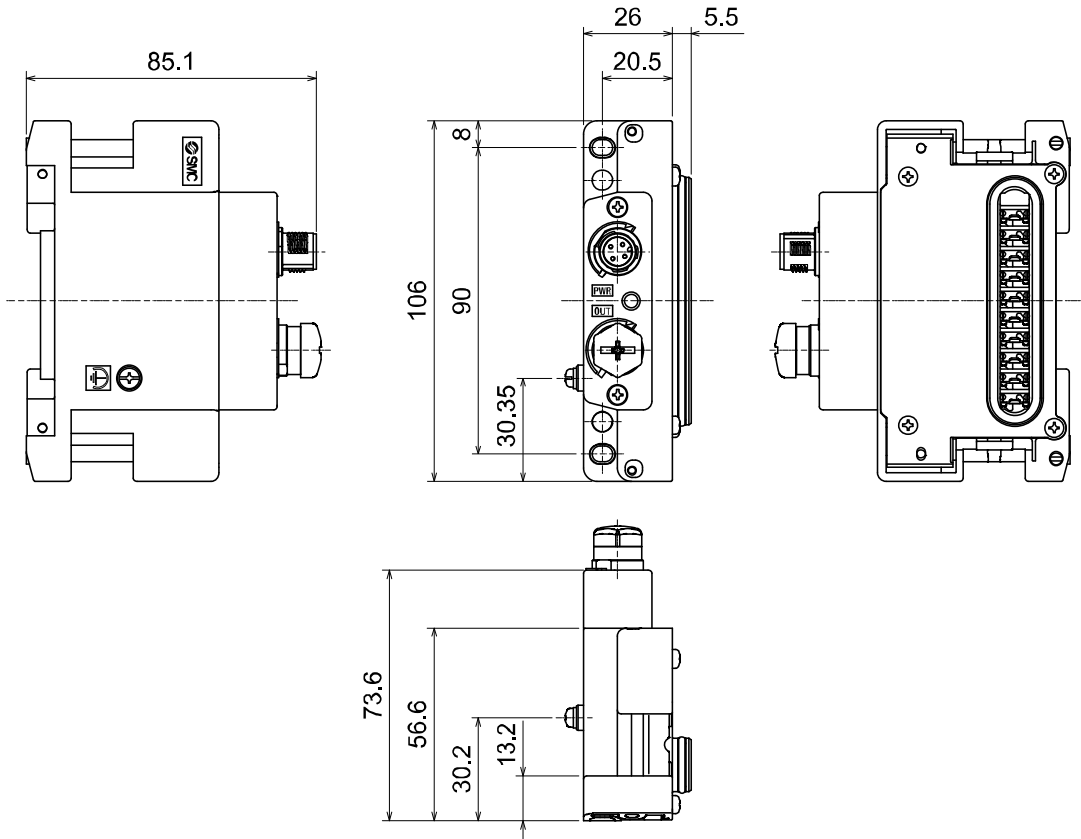

•EX600-ED4/ED5-2

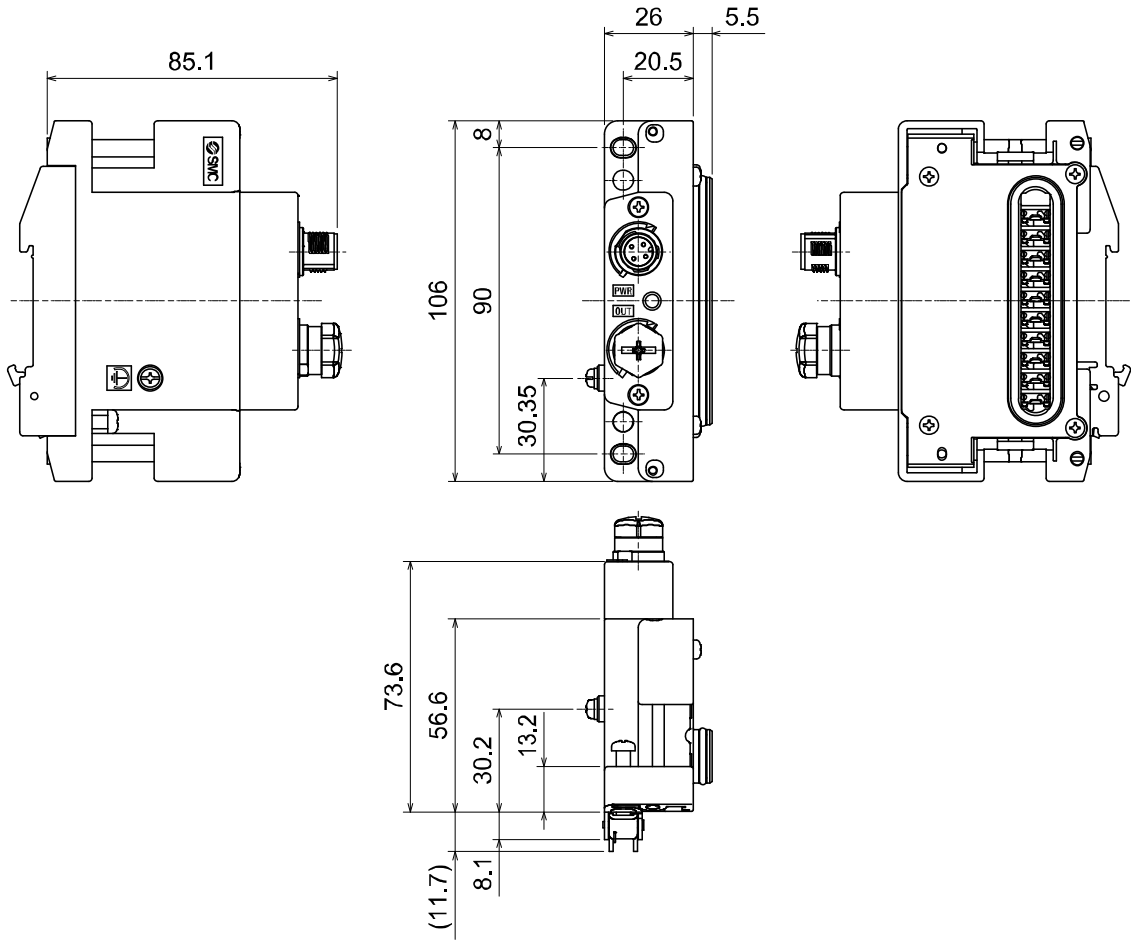

•EX600-ED4/ED5-3

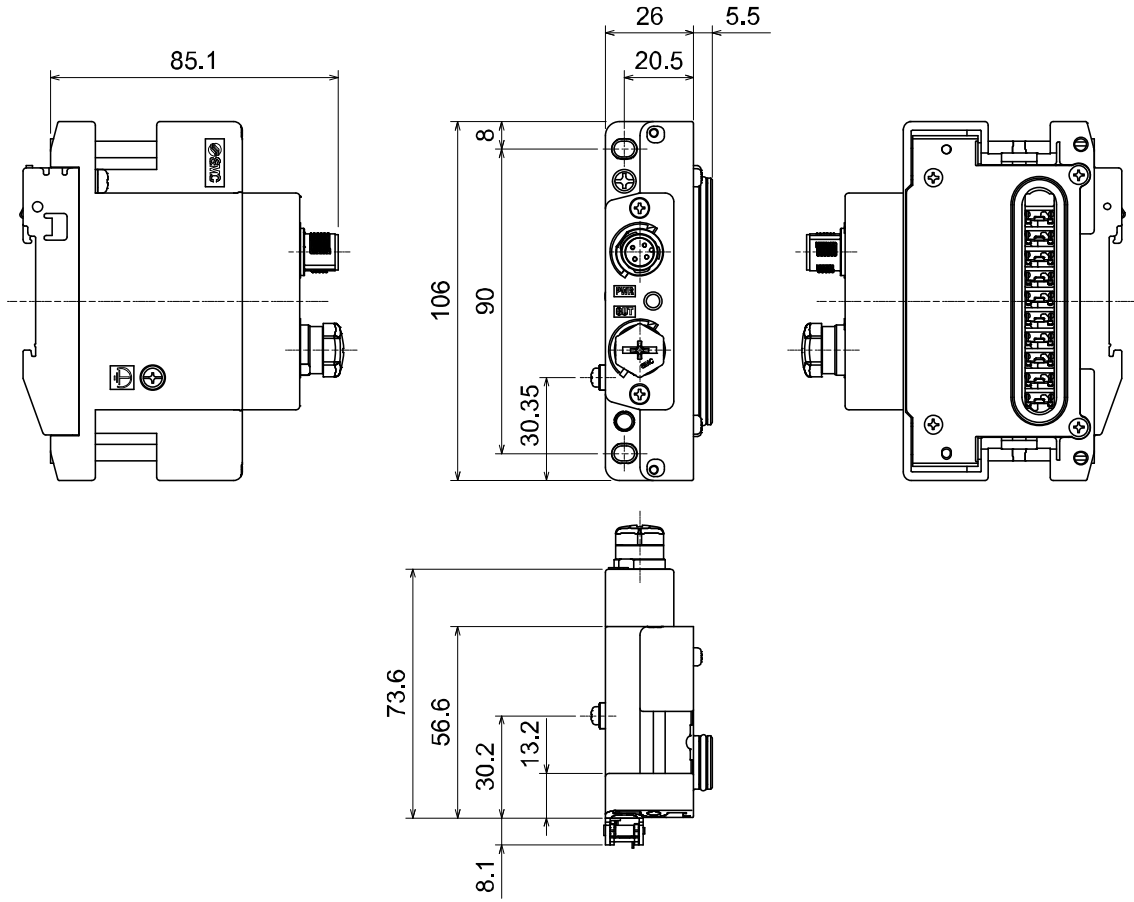

•EX600-EU1

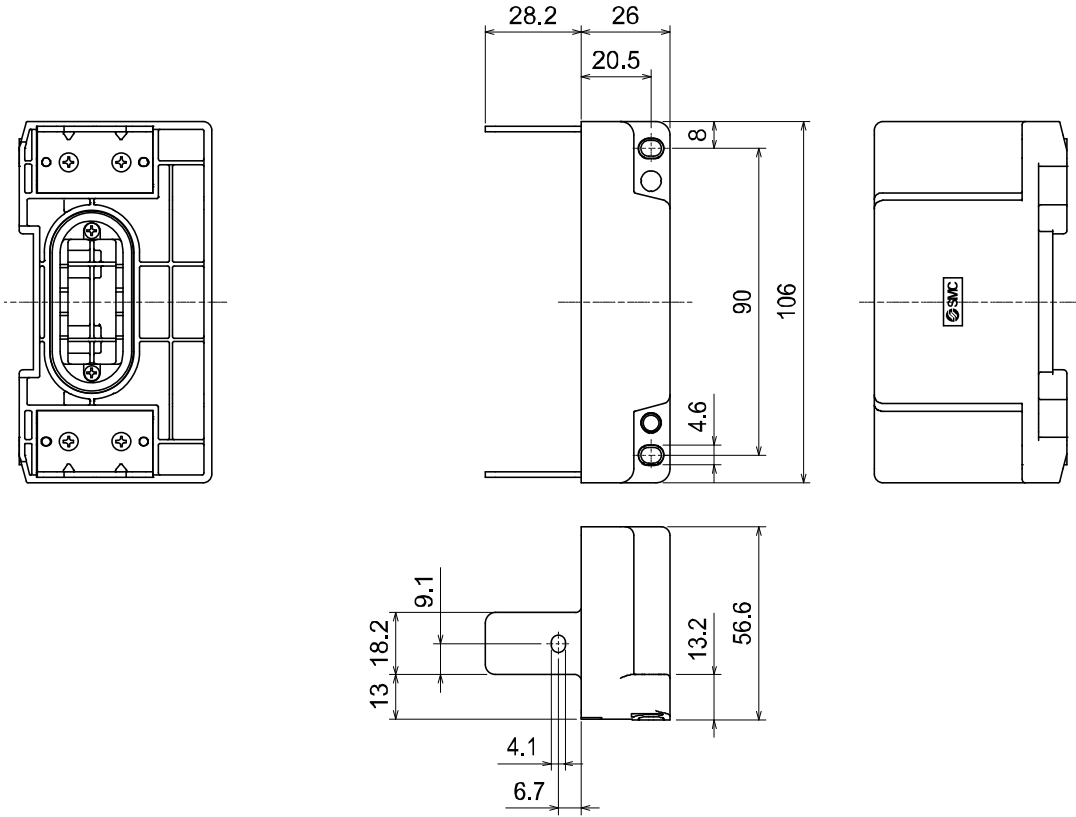

•EX600-EU1-2

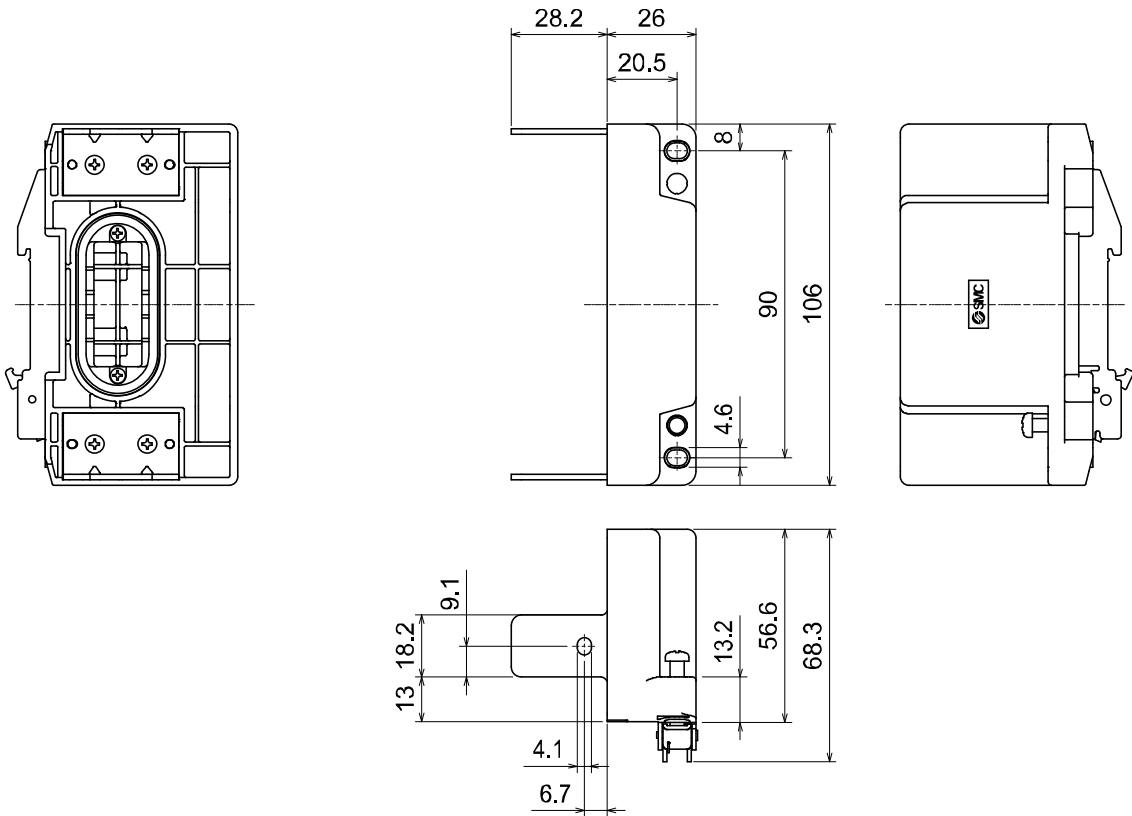

•EX600-EU1-3

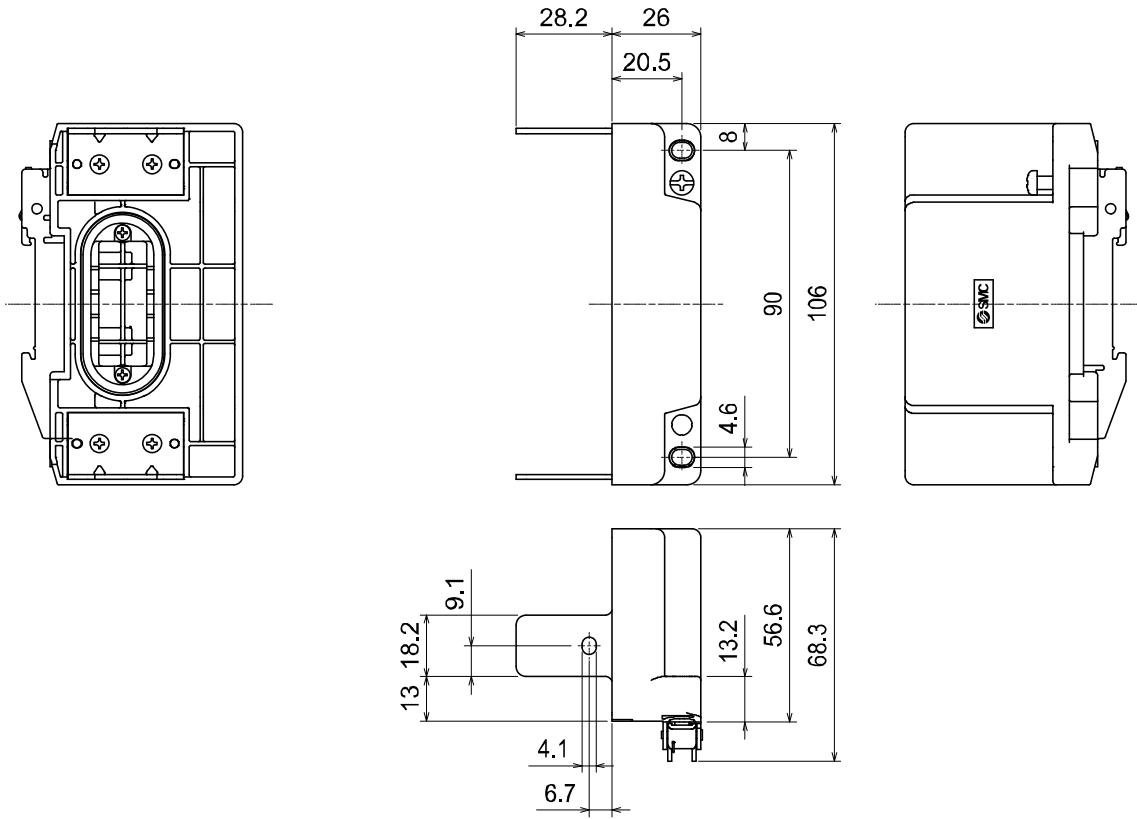

Maintenance

Turn off the power supply, stop the supplied air, exhaust the residual pressure and verify the release of air before performing maintenance.

Cleaning method

Use a soft cloth to remove stains.

For heavy stains, use a cloth soaked with diluted neutral detergent and fully squeezed, then wipe up the stains again with a dry cloth.

Do not use solvents such as benzene, thinner etc. to clean each unit.

Inspection item	Content of inspection
Connector/Electric wiring	Connect properly if the connection is loose.
Seal cap	Tighten properly if the connection is loose.
Thread for mounting and installation	If the thread is loose, re-tighten it to the specified torque.
Connection cables	If the cable is broken or any other abnormality is confirmed by appearance, replace the cable with a new one.
Supply source voltage	Check if source voltage within the specification range (24 VDC \pm 10%) is supplied.

How to reset the product for power cut or forcible de-energizing

Supply power to the product.

The output status just before the power failure is not maintained when power supply is recovered.

Start operation after confirming safety of the entire equipment.

Troubleshooting

•Troubleshooting

When any failure happens with this fieldbus system, the following chart is used to identify the cause of the failure.

Error status is reflected from the parameter setting of the fieldbus system.

When a failure occurs, take the appropriate countermeasures referring to the LED display, the troubleshooting and the parameter setting.

If a cause applicable to the failure cannot be identified, it indicates that the fieldbus system itself is broken.

The fieldbus system breakage can be caused by the operating environment. Contact SMC separately to obtain countermeasures.

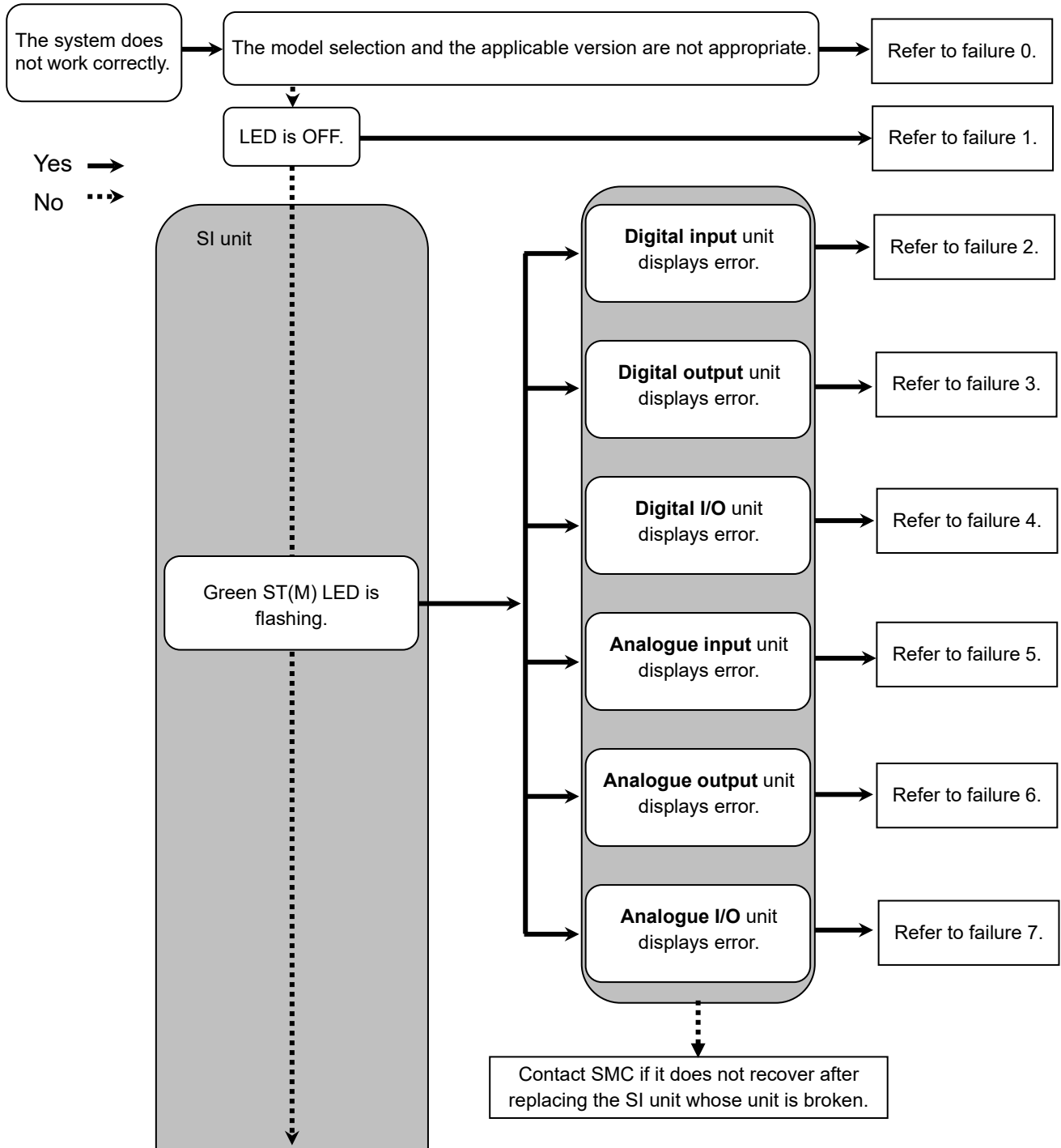

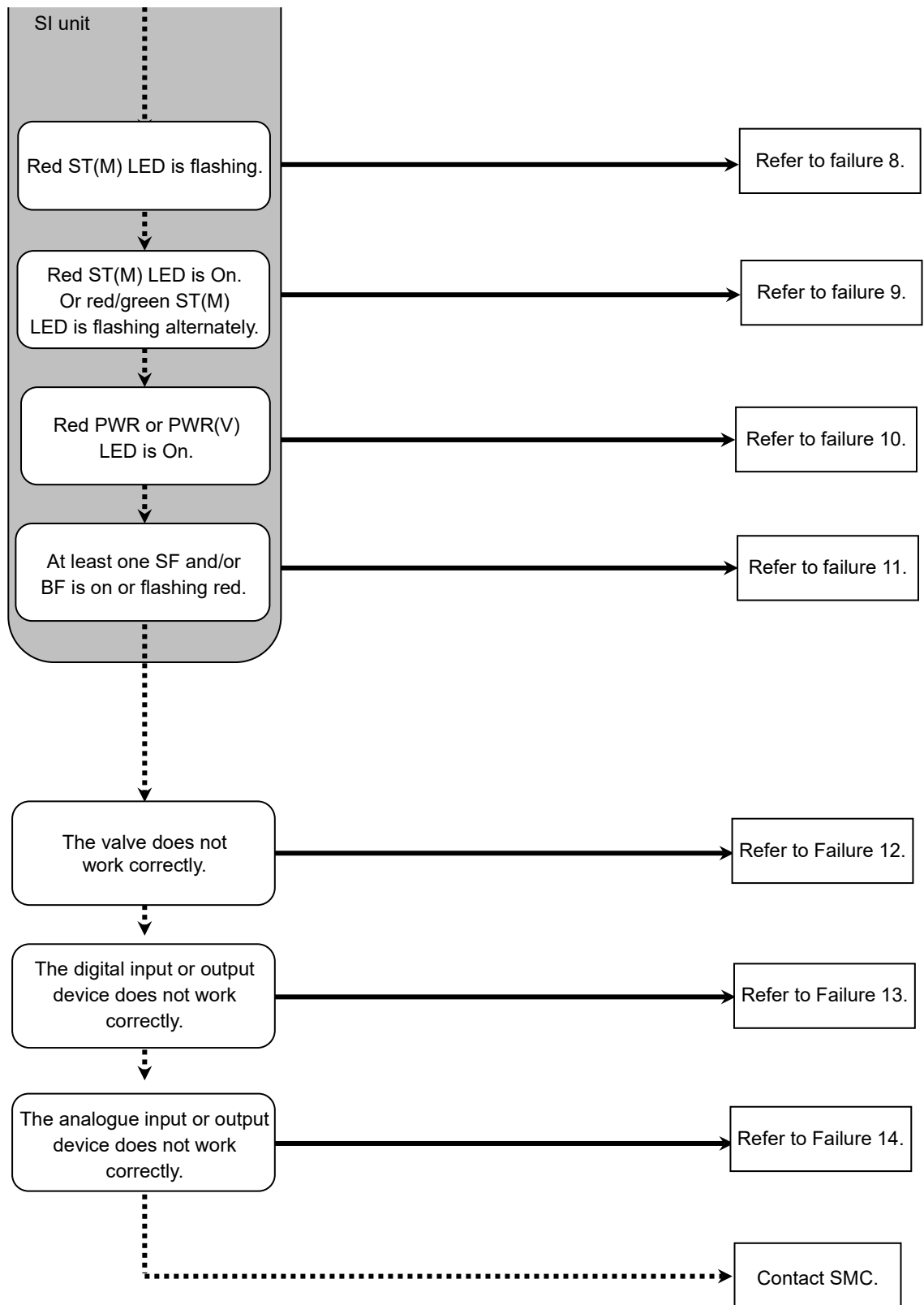

•Trouble counter measure method

No.	Part No. EX600-	Problem	Presumed cause	Troubleshooting
0	-	The system does not work correctly.	Inappropriate unit selection.	The types of units that can be connected vary depending on the SI unit part number. Check if the unit is applicable before assembly.
1	-	LED is OFF.	Power supply for control and input is OFF.	Check if the power for control and input is supplied.
2	DX#B DX#C# DX#D	Red LED is ON. (When diagnosis is activated)	Diagnosis error Input device power supply is short-circuited.	Check the parts with error by using the LED display or PLC * or H.T. Re-wire the short-circuited part or check if the cable and input device are normal.
		Red LED is flashing. (When diagnosis is activated)	Diagnosis error (1) ON/OFF count of the input device has exceeded the set value. (2) The wire of the input device is broken or disconnected. (Only EX600-DX#C1)	Check the parts with error by using the LED display or PLC * or H.T. (1) Reset the ON/OFF count to zero or change the set value. Or invalidate diagnosis. (2) Check if the connector is loose and if the wire is broken.
		Other displays	Unit has failed.	Stop the operation and contact SMC.
	DX#E DX#F	Red ST LED is ON. (When diagnosis is activated)	Diagnosis error Input device power supply is short-circuited.	Check the parts with error by using the LED display or PLC * or H.T. Re-wire the short-circuited part or check if the cable and input device are normal.
		Red ST LED is flashing. (When diagnosis is activated)	Diagnosis error ON/OFF count of the input device has exceeded the set value.	Check the parts with error by using the LED display or PLC * or H.T. Reset the ON/OFF count to zero or change the set value. Or invalidate diagnosis.
		Other displays.	Unit has failed.	Stop the operation and contact SMC.

*: Refer to "System diagnostic data" (page 74) for details.

No.	Part No. EX600-	Problem	Presumed cause	Troubleshooting
3	DY#B	Red LED is ON. (When diagnosis is activated)	Diagnosis error Output device is short-circuited.	Check the parts with error by using the LED display or PLC * or H.T. Re-wire the short-circuited part or check if the cable and output device are normal.
		Red LED is flashing. (When diagnosis is activated)	Diagnosis error (1) ON/OFF count of the output device has exceeded the set value. (2) The wire of the output device is broken or disconnected.	Check the parts with error by using the LED display or PLC * or H.T. (1) Reset the ON/OFF count to zero or change the set value. Or invalidate diagnosis. (2) Check if the connector is loose and if the wire is broken.
		Other displays.	Unit has failed.	Stop the operation and contact SMC.
	DY#E DY#F	Red ST LED is ON. (When diagnosis is activated)	Diagnosis error Output device is short-circuited.	Check the parts with error by using the LED display or PLC * or H.T. Re-wire the short-circuited part or check if the cable and output device are normal.
		Red ST LED is flashing. (When diagnosis is activated)	Diagnosis error (1) ON/OFF count of the output device has exceeded the set value. (2) The wire of the output device is broken or disconnected.	Check the parts with error by using the LED display or PLC * or H.T. (1) Reset the ON/OFF count to zero or change the set value. Or invalidate diagnosis. (2) Check if the connector is loose and if the wire is broken.
		Other displays.	Unit has failed.	Stop the operation and contact SMC.
4	DM#E DM#F	Red ST(I) LED is ON. (When diagnosis is activated)	Diagnosis error Input device power supply is short-circuited.	Check the parts with error by using the LED display or PLC * or H.T. Re-wire the short-circuited part or check if the cable and input device are normal.
		Red ST(I) LED is flashing. (When diagnosis is activated)	Diagnosis error ON/OFF count of the input device has exceeded the set value.	Check the parts with error by using the LED display or PLC * or H.T. Reset the ON/OFF count to zero or change the set value. Or invalidate diagnosis.
		Red ST(O) LED is ON. (When diagnosis is activated)	Diagnosis error Output device is short-circuited.	Check the parts with error by using the LED display or PLC * or H.T. Re-wire the short-circuited part or check if the cable and output device are normal.
		Red ST(O) LED is flashing. (When diagnosis is activated)	Diagnosis error (1) ON/OFF count of the output device has exceeded the set value. (2) The wire of the output device is broken or disconnected.	Check the parts with error by using the LED display or PLC * or H.T. (1) Reset the ON/OFF count to zero or change the set value. Or invalidate diagnosis. (2) Check if the connector is loose and if the wire is broken.
		Other displays.	Unit has failed.	Stop the operation and contact SMC.

*: Refer to "System diagnostic data" (page 74) for details.

No.	Part No. EX600-	Problem	Presumed cause	Troubleshooting
5	AXA	Red LED is ON. (When diagnosis is activated)	Diagnosis error Analogue input device power supply is short-circuited.	Check the parts with error by using the LED display or PLC * or H.T. Re-wire the short-circuited part, and check if the cable and analogue input device are normal.
		"0 and 1" red LEDs are ON.	Input value has exceeded the upper limit when set to Current input type range.	Check the following when the range of the analogue input unit is set to current input. (1) Set the input value of the analogue input device so that it does not exceed the upper limit. (2) Voltage is input from the analogue input device. Ensure the range of the input unit matches the range of the input device.
		Red LED is flashing. (When diagnosis is activated)	Diagnosis error (1) Input value has exceeded the upper or lower limit of the range. (2) Input value (value set by user) has exceeded the upper or lower limit.	(1) If the input value from the analogue input device exceeds the upper or lower limit of the range, select the appropriate range so that the input value is within the range. Or invalidate diagnosis. (2) If the input value from the analogue input device exceeds the upper or lower limit of the user set value, adjust it so that the input value is within the range of the user set value. Or invalidate diagnosis.
		Other displays.	Unit has failed.	Stop the operation and contact SMC.
6	AYA	Red LED is ON. (When diagnosis is activated)	Diagnosis error Analogue output device power supply is short-circuited.	Check the parts with error by using the LED display or PLC * or H.T. Re-wire the short-circuited part, and check if the cable and analogue output device are normal.
		Red LED is flashing. (When diagnosis is activated)	Diagnosis error Output value (value set by user) has exceeded the upper or lower limit.	If the output value from the analogue output device exceeds the upper or lower limit of the user set value, adjust it so that the output value is within the range of the user set value. Or invalidate diagnosis.
		Other displays.	Unit has failed.	Stop the operation and contact SMC.

*: Refer to "System diagnostic data" (page 74) for details.

No.	Part No. EX600-	Problem	Presumed cause	Troubleshooting
7	AMB	Red LED is ON. (When diagnosis is activated)	Diagnosis error Analogue input or output device power supply is short-circuited.	Check the parts with error by using the LED display or PLC * or H.T. Re-wire the short-circuited part, and check if the cable and analogue input or output device are normal.
		"0 and 1" red LEDs are ON.	Input value has exceeded the upper limit when set to current input type range.	Check the following when the range of the analogue input unit is set to current input. (1) Set the input value of the analogue input device so that it does not exceed the upper limit. (2) Voltage is input from the analogue input device. Ensure the range of the input unit matches the range of the input device.
		Red LED is flashing. (When diagnosis is activated)	Diagnosis error (1) Input value has exceeded the upper or lower limit of the range. (2) Input or output value (value set by user) has exceeded the upper or lower limit.	(1) If the input value from the analogue input device exceeds the upper or lower limit of the range, select the appropriate range so that the input value is within the range. Or invalidate diagnosis. (2) If the input (output) value from the analogue input (output) device exceeds the upper or lower limit of the user set value, adjust it so that the input(output) value is within the range of the user set value. Or invalidate diagnosis.
		Other displays.	Unit has failed.	Stop the operation and contact SMC.
8		Red ST(M) LED is flashing. (When diagnosis is activated)	Diagnosis error (SI unit) (1) Valve is short-circuited. (2) Wire of the valve is open-circuited. (3) ON/OFF count of the valve has exceeded the set value.	Check the parts with error by using the LED display or PLC * or H.T. (1) Check the operation after replacing the valve. (2) Check the operation after replacing the valve. (3) Reset the ON/OFF count to zero or change the set value. Or invalidate diagnosis.
9		Red ST(M) LED is ON.	SI unit has failed.	Stop the operation and contact SMC.
		Red/green ST(M) LED is flashing alternately.	Connection between the units is defective.	Confirm that there is no loose connection between the units and connect them correctly.
10		Red PWR LED is ON. (When diagnosis is activated)	Power supply voltage for control and input is abnormal.	Supply 24 VDC \pm 10% for control and input power source.
		Red PWR(V) LED is ON. (When diagnosis is activated)	Power supply voltage for output is abnormal.	Supply 24 VDC +10/-5% for output power source.

*: Refer to "System diagnostic data" (page 74) for details.

No.	Problem	Presumed cause	Troubleshooting
11	SF: Red LED is ON BF: OFF (When diagnosis is activated)	Diagnosis error (Among PLC and each unit)	Check the LED display of each unit, and take countermeasures referring to failure No.2 to7.
	SF: OFF BF: Red LED is ON	PROFIBUS communication is abnormal.	Check the proper wiring length for the communication speed. Check if it has terminating resistors on both ends of the network. Keep the communication line away from noise sources. Connect wires based on PROFIBUS DP specifications.
	SF: Red LED is ON BF: Red LED is ON	Address setting is defective.	If the SI unit address is set to "0" or "126" or more, set it to between "1" and "125".
	SF: Red LED is ON BF: Red LED is flashing	Configuration does not match.	Check the configuration setting of PLC, and ensure it matches the actual configuration.
	SF: OFF BF: Red LED is flashing	Address setting is defective.	If the SI unit address is different from the PLC setting address, set the correct address which matches with the PLC setting address.
12	Abnormal valve operation	The number of connected valves is larger than the number of occupied valve outputs.	When the number of occupied valves of the V_SEL switch is smaller than the number of connected valves, set the switch so that the number of occupied valves is not smaller than the number of valves to be used.
		Abnormality with program, etc.	Check if the ladder program of PLC, etc. is correct.
		Abnormal power supply for output.	Check if the green Power LED of the SI unit is ON. If the LED is OFF, or the red LED is on, supply 24 VDC +10/-5% to the power supply for output.
		Polarity of output does not match.	Check the connectors between the SI unit and manifold valve are not damaged, such as bent pins, and connect them correctly.
		Output configuration of the SI unit does not match.	IF the polarity of the SI unit and the valve are different, replace one of them to make the combination match. •EX600-SPR1A (PNP output) ⇒ Negative common type valve •EX600-SPR2A (NPN output) ⇒ Positive common type valve
		SI unit has failed.	Replace the SI unit with a normal one, and check the operation.
Valve failure.	Replace the valve with a normal one, and check the operation. Or refer to the troubleshooting of the valve used.		

No.	Problem	Presumed cause	Troubleshooting
13	Abnormal digital input device operation	Polarity of input does not match.	If the polarity (PNP, NPN) of the input unit and the input device are different, replace one of them to make the combination match.
		Power supply for control and input is abnormal.	Check if the green Power LED of the SI unit is on. If the LED is OFF, or the red LED is on, supply 24 VDC $\pm 10\%$ to the power supply for control and input.
		Wiring or connection is defective.	Connect the wiring correctly between the digital input device and the digital input unit.
		Input unit has failed.	Replace the input unit with a normal one, and check the operation.
		Input device failure.	Replace the input device with a normal one, and check the operation. Or refer to the troubleshooting of the input device used.
	Abnormal digital output device operation	Polarity of output does not match.	If the polarity (PNP, NPN) of the output unit and the output device are different, replace one of them to make the combination match.
		Power supply for output is abnormal.	Check if the green Power LED of the SI unit is on. If the LED is OFF, or the red LED is on, supply 24 VDC $+10/-5\%$ to the power supply for output.
		Wiring or connection is defective.	Connect the wiring correctly between the digital output device and the digital output unit.
		Output unit has failed.	Replace the Output unit with a normal one, and check the operation.
		Output device failure.	Replace the output device with a normal one, and check the operation. Or refer to the troubleshooting of the output device used.
		Program etc. is defective.	Check whether the ladder program etc. of PLC are correct.

No.	Problem	Presumed cause	Troubleshooting
14	Abnormal analogue input device operation	Power supply for control and input is abnormal.	Check if the green Power LED of the SI unit is ON. If the LED is OFF, or the red LED is ON, supply 24 VDC $\pm 10\%$ to the power supply for control and input.
		Analogue input signal range setting failure.	Check the analogue input device specification, and set the input signal range which satisfies the specification.
		Analogue data format does not match.	Check whether the data format of the analogue input unit is properly set.
		Wiring or connection is defective.	Connect the wiring correctly between the analogue input device and the analogue input unit.
		Analogue input unit has failed.	Replace the analogue input unit with a normal one, and check the operation.
		Analogue input device failure.	Replace the analogue input device with a normal one, and check the operation. Or refer to the troubleshooting of the analogue input device used.
	Abnormal analogue output device operation	Power supply for output is abnormal.	Check if the green Power LED of the SI unit is ON. If the LED is OFF, or the red LED is ON, supply 24 VDC $+10/-5\%$ to the power supply for output.
		Analogue output signal range setting failure.	Check the analogue output device specification, and set the output signal range which satisfies the specification.
		Analogue data format does not match.	Check whether the data format of the analogue output unit is properly set.
		Wiring or connection is defective.	Connect the wiring correctly between the analogue output device and the analogue output unit.
		Analogue output unit has failed.	Replace the analogue output unit with a normal one, and check the operation.
		Analogue output device failure.	Replace the analogue output device with a normal one, and check the operation. Or refer to the troubleshooting of the analogue output device used.
		Program etc. is defective.	Check whether the ladder program etc. of PLC are correct.

Parameter Setting

The product has parameters that can be set for the system, each unit or each channel.
 The parameters can be changed using the PLC and H.T.
 There is no order of precedence of the PLC and H.T. The latest parameter settings are used.

- Precautions for handling
 - Changing parameters with the H.T. does not change the parameter settings in the PLC.
 - If PROFIBUS communication is cut after changing parameters with the H.T. and the communication is connected again, the content of parameters will be changed to those set in the PLC.

■Parameter definition and setting

•System parameters

No.	Parameter (H.T. Symbol)	Definition	Item	Content	Default setting	Parameter setting	
						By PLC	By H.T.
1	Hold/Clear priority setting (Hold/Clear)	Switch the setting of the output during communication error or communication idling to follow the SI unit switch or the H.T.	Switch	Setting by SI unit switch becomes valid. OFF/Hold can be set all outputs.	○		
			Handheld	Setting by the H.T. becomes valid. OFF/Hold/Forced ON can be set per channel.		○	○
2	Diagnostic mode (Diag. mode)	Shifts the extension diagnosis information map. Refer to "Diagnostic" (page 71) for details.	No.diag.	Only the standard diagnosis is performed.			
			Device diag.	The standard and system diagnoses are performed.			
			Device + Module diag.	The standard, system and unit diagnoses are performed.		○	×
			Device + Module + Channel diag.	The standard, system, unit and channel diagnoses are performed.	○		

•SI unit parameters

No.	Parameter (H.T. Symbol)	Definition	Item	Content	Default setting	Parameter setting	
						By PLC	By H.T.
1	Power supply for control and input voltage monitor (PWRC_Mon)	Generated error per unit when control and input power supply voltage goes over approx. 26 V or under 21 V.	Enable	Generates an error.	○	○	○
			Disable	Does not generate an error.			
2	Power supply for output voltage monitor (PWRO_Mon)	Generated error per unit when output power supply voltage goes over approx. 26 V or under 20 V.	Enable	Generates an error.	○	○	○
			Disable	Does not generate an error.			
3	Short Circuit Detection (SC_MonOp)	Generates error per unit when the short circuit of the valve is detected.	Enable	Generates an error.	○	○	○
			Disable	Does not generate an error.			
4	Restart after short circuit (SC_RstOp)	Restore the setting of short circuit detection error per unit after the valve short circuit is cleared.	Auto	Error is automatically cleared when the short circuit is fixed.	○	○	○
			Manual	Even when the short circuit is fixed, error is not cleared until the power is supplied again.			
5	Open Circuit Detection (OC_Mon)	Generates error per channel when the disconnection of the valve is detected.	Enable	Generates an error.		×	○
			Disable	Not generated an error.	○		
6	Output setting during communication fault *1 (Fault_MD)	Sets output per channel when communication is abnormal.	Clear	Turn off the output.	○	×	○
			Hold	Hold the output.			
			ForceON	Turn on the output forcefully.			
7	Output setting during communication idling *1 (Idle_MD)	Sets output per channel during communication idling.	Clear	Turn off the output.	○	×	○
			Hold	Hold the output.			
			ForceON	Turn on the output forcefully.			
8	Valve ON/OFF counter (Counter)	Memorizes the number of times the valve is ON. Generates error per channel when the operation count exceeds the set value. *2	Enable	Generates an error. Val: 1 to 65000 *3		×	○
			Disable	Does not generate an error.	○		

*1: This function is valid only when "Hold/Clear priority" of the system parameter is set to "Handheld".

*2: The count is memorized every 30 seconds per channel. When the power supply is turned on again, counting starts from the last value memorized.

*3: Times for setting is set value x1000 times.

•Digital input unit parameters

No.	Parameter (H.T. Symbol)	Definition	Item	Content	Default setting	Parameter setting	
						By PLC	By H.T.
1	The power supply short circuit detection for control and input (SC_MonSs)	Generates error per unit when the short circuit of the power supply for the input device is detected.	Enable	Generates an error.	○	○	○
			Disable	Does not generate an error.			
2	Open circuit detection *1 (OC_Mon)	Generates error per channel when the disconnection of the input device is detected. *2	Enable	Generates an error.		×	○
			Disable	Does not generate an error.	○		
3	Inrush current filter (Inrush)	Ignores excess current per unit for 100 msec after inrush.	Enable	Ignores excess current.		○	○
			Disable	Does not ignore excess current.	○		
4	Input filtering time (Filter_T)	Sets the time to ignore the input signal change per unit.	0.1 ms	Selects the time for filtering.	1.0 ms	○	○
			1.0 ms				
			10 ms				
			20 ms				
5	Input extension time (SigExt_T)	Sets the time to hold the input signal per unit.	1.0ms	Selects the time to hold the input signal.	15 ms	○	○
			15 ms				
			100 ms				
			200 ms				
6	Channel ON/OFF counter (Counter)	Memorizes the number of times the input device is ON. Generates error per channel when the operation count exceeds the set value. *3	Enable	Generates an error. Val: 1 to 65000 *4		×	○
			Disable	Does not generate an error.	○		

*1: Disconnection detection is a function only available for digital unit (EX600-DXPC1, EX600-DXNC1) with disconnection detection.

*2: 2-wire type input device cannot be correctly detected if its leakage current is 0.5 mA or less while the equipment is in the OFF state (reed sensor, etc.). Ensure that all input device used has a leakage current above 0.5 mA in the OFF state.

3-wire type input device cannot be correctly detected if its current consumption is 0.5mA or less. The open circuit of input signals cannot be detected.

*3: The count is memorized every hour. When the power supply is turned on again, counting starts from the last value memorized.

*4: Times for setting is set value x1000 times.

•Digital output unit parameters

No.	Parameter (H.T. Symbol)	Definition	Item	Content	Default setting	Parameter setting	
						By PLC	By H.T.
1	Output load short circuit detection (SC_MonOp)	Generates error per unit when the short circuit of the output device is detected. *1	Enable	Generates an error.	○		
			Disable	Does not generate an error.		○	○
2	Restart after output load short circuit (SC_RstOp)	Restore the setting of short circuit detection error per unit after the output device short circuit is cleared.	Auto	Error is automatically cleared when the short circuit is fixed.	○		
			Manual	Even when the short circuit is fixed, error is not cleared until the power is supplied again.		○	○
3	Open circuit detection (OC_Mon)	Generates error per channel when the disconnection of the output device is detected.	Enable	Generates an error.			
			Disable	Does not generate an error.	○	×	○
4	Output setting during communication fault *2 (Fault_MD)	Sets output per channel when communication is abnormal.	Clear	Turn off the output.	○		
			Hold	Hold the output.		×	○
			ForceON	Turn on the output forcefully.			
5	Output setting during communication idling *2 (Idle_MD)	Sets output per channel during communication idling.	Clear	Turn off the output.	○		
			Hold	Hold the output.		×	○
			ForceON	Turn on the output forcefully.			
6	Output ON/OFF counter (Counter)	Memorizes the number of times the output device is ON. Generates error per channel when the operation count exceeds the set value. *3	Enable	Generates an error. Val: 1 to 65000 *4			
			Disable	Does not generate an error.	○	×	○

*1: Could be incorrectly recognized as short circuit depending on used load (ex.: lamp load). If detection is incorrect, disable the parameter setting.

*2: This function is valid only when "Hold/Clear priority" of the system parameter is set to "Handheld".

*3: The count is memorized every hour. When the power supply is turned on again, counting starts from the last value memorized.

*4: Times for setting is set value x1000 times.

•Digital I/O unit parameters

No.	Parameter (H.T. Symbol)	Definition	Item	Content	Default setting	Parameter setting	
						By PLC	By H.T.
1	The power supply short circuit detection for control and input (SC_MonSs)	Generates error per unit when the short circuit of the control or input power supply is detected.	Enable	Generates an error.	○	○	○
			Disable	Does not generate an error.			
2	Inrush current filter (Inrush)	Ignores excess current per unit for 100 msec. after inrush.	Enable	Ignores excess current.	○	○	○
			Disable	Does not ignore excess current			
3	Input filtering time (Filter_T)	Sets the time to ignore the input signal change per unit	0.1 ms	Selects the time for filtering.	1.0 ms	○	○
			1.0 ms				
			10 ms				
			20 ms				
4	Input extension time (SigExt_T)	Sets the time to hold the input signal per unit.	1.0 ms	Selects the time to hold the input signal.	15 ms	○	○
			15 ms				
			100 ms				
			200 ms				
5	Output load short circuit detection (SC_MonOp)	Generates error per unit when the short circuit of the output device is detected. *1	Enable	Generates an error.	○	○	○
			Disable	Does not generate an error.			
6	Restart after output load short circuit (SC_RstOp)	Restore the setting of short circuit detection error per unit after the output device short circuit is cleared.	Auto	Error is automatically cleared when the short circuit is fixed.	○	○	○
			Manual	Even when the short circuit is fixed, error is not cleared until the power is supplied again.			
7	Open circuit detection (OC_Mon)	Generates error per channel when the disconnection of the output device is detected.	Enable	Generates an error.	○	×	○
			Disable	Does not generate an error.			
8	Output setting during communication fault *2 (Fault_MD)	Sets output per channel when communication is abnormal.	Clear	Turn off the output.	○	×	○
			Hold	Hold the output.			
			ForceON	Turn on the output forcefully.			
9	Output setting for communication idling *2 (Idle_MD)	Sets the output per channel during communication idling.	Clear	Turn off the output.	○	×	○
			Hold	Hold the output.			
			ForceON	Turn on the output forcefully.			
10	Input or output ON/OFF counter (Counter)	Memorizes the number of times the input or output device is ON. Generates error per channel when the operation count exceeds the set value. *3	Enable	Generates an error. Val: 1 to 65000 *4	○	×	○
			Disable	Does not generate an error.			

*1: Could be incorrectly recognized as short circuit depending on used load (ex.: lamp load). If detection is incorrect, disable the parameter setting.

*2: This function is valid only when "Hold/Clear priority" of the system parameter is set to Handheld.

*3: The count is memorized every hour. When the power supply is turned on again, counting starts from the last value memorized.

*4: Times for setting is set value x1000 times.

•Analogue input unit parameters

No.	Parameter (H.T. Symbol)	Definition	Item	Content	Default setting	Parameter setting	
						By PLC	By H.T.
1	The power supply short circuit detection for the input device (SC_MonSs)	Generates error per unit when the short circuit of the power supply for the input device is detected.	Enable	Generates an error.	○		
			Disable	Does not generate an error.		○	○
2	Analogue input range (Range)	Sets the analogue input device range per channel.	-10..10 V	Selects the analogue input range.	-10..10 V	○	○
			-5..5 V				
			-20..20 mA				
			0..10 V				
			0..5 V				
			1..5 V				
			0..20 mA				
4..20 mA							
3	Analogue data format (D_Format)	Sets analogue data type which is output to PLC per unit.	Offset binary	Offset binary.	○		
			Sign & Magnitude	Signed binary.		○	○
			2S Complement	2's complement.			
4	Analogue average filter (Filter)	Sets analogue filtering time per channel. Sampling interval is approx. 2 sec.	None	None			
			2AVG	2 value average	○		○
			4AVG	4 value average			
			8AVG	8 value average			
5	Over range detection (Over_Rng)	Generates error per unit when the input value exceeds 0.5% of full span.	Enable	Generates an error.	○		
			Disable	Does not generate an error.		○	○
6	Under range detection (Undr_Rng)	Generates error per unit when the input value falls below 0.5% of full span.	Enable	Generates an error.	○		
			Disable	Does not generate an error.		○	○
7	User setting value upper limit error (Upr_Lmt)	Generates error per unit when the input value exceeds the set value.	Enable	Generates an error. *1			
			Disable	Does not generate an error.	○	×	○
8	User setting value lower limit error (Lwr_Lmt)	Generates error per channel when the input value falls below the set value.	Enable	Generates an error. *1			
			Disable	Does not generate an error.	○	×	○

*1: Set value shall be set per analogue input range within settable range in the table below. When the analogue input range is changed, check the set value and change it to an appropriate value.

Analogue input measurement range. (Range)	Upper and lower setting limit of user setting.	
	(Lwr_Lmt)	(Upr_Lmt)
-10..10 V	-10.50 to +10.45 V	-10.45 to +10.50 V
-5..5 V	- 5.25 to + 5.22 V	- 5.22 to +5.25 V
-20..20 mA	-21.00 to +20.90 mA	-20.90 to +21.00 mA
0..10 V	0.00 to +10.45 V	+0.05 to +10.50 V
0..5 V	0.00 to +5.22 V	+0.03 to +5.25 V
1..5 V	+0.75 to +5.22 V	+0.78 to +5.25 V
0..20 mA	0.00 to +20.90 mA	+0.10 to +21.00 mA
4..20 mA	+3.00 to +20.90 mA	+3.10 to +21.00 mA

•Analogue output unit parameters (1)

No.	Parameter (H.T. Symbol)	Definition	Item	Content	Default setting	Parameter setting	
						By PLC	By H.T.
1	The power supply short circuit detection for the output device (SC_MonSs)	Generates error per unit when the short circuit of the output device is detected.	Enable	Generates an error.	○		
			Disable	Does not generate an error.		○	○
2	Analogue output range (Range)	Sets the range of the analogue output device per channel.	0..10 V	Selects the analogue output range.	0..10 V	○	○
			0..5 V				
			1..5 V				
			0..20 mA				
			4..20 mA				
3	Analogue data format (D_Format)	Sets analogue data type which is output to PLC per unit.	Offset binary	Offset binary.	○		
			Sign & Magnitude	Signed binary.		○	○
			2S Complement	2's complement.			
			Scaled	Scale conversion type.			
4	User setting value upper limit error (Upr_Lmt)	Generates error per channel when the output value exceeds the set value.	Enable	Generates an error. *2			
			Disable	Does not generate an error.	○		
	Scale upper limit setting *1 (UpLm/Scl)	Sets the scale upper limit. Generates error per channel when the output value exceeds the upper limit.	Enable	Generates an error. Val: -32766 to 32767		×	○
			Disable	Does not generate an error. Val: -32766 to 32767	○ Val: 1000		
5	User setting value lower limit error (Lwr_Lmt)	Generates error per channel when the output value falls below the set value.	Enable	Generates an error. *2			
			Disable	Does not generate an error.	○		
	Scale lower limit setting *1 (LwLm/Scl)	Sets the scale lower limit. Generates error per channel when the output value falls below the lower limit.	Enable	Generates an error. Val: -32767 to 32766		×	○
			Disable	Does not generate an error. Val: -32767 to 32766	○ Val: 0		
6	Output setting for communication fault *3 (Fault_MA)	Sets output per channel when communication is abnormal.	Enable	Val is output. *2		×	○
			Disable	The output is held.	○		

•Analogue output unit parameters (2)

No.	Parameter (H.T. Symbol)	Definition	Item	Content	Default setting	Parameter setting	
						By PLC	By H.T.
7	Output setting for communication idling *3 (Idle_MA)	Sets output per channel during communication idling.	Enable	Val is output. *2			
			Disable	The output is held.	○	×	○

*1: When "Scaled" is selected as the analogue data format, the display of H.T. is switched from Upr_Lmt to UpLm/Scl, from Lwr_Lmt to LwLm/Scl.

*2: Set value shall be set per analogue input range within settable range in the table below. When the analogue input range is changed, check the set value and change it to an appropriate value.

*3: This function is valid only when "Hold/Clear priority" of the system parameter is set to Handheld.

Analogue output measurement range. (Range)	Upper and lower setting limit of user setting.		Settable range during communication fault or idling. (Fault_MA) (Idle_MA)
	(Lwr_Lmt)	(Upr_Lmt)	
0..10 V	0.00 to +10.45 V	+0.05 to +10.50 V	0.00 to +10.50 V
0..5 V	0.00 to + 5.22 V	+0.03 to +5.25 V	0.00 to +5.25 V
1..5 V	+0.75 to +5.22 V	+0.78 to +5.25 V	+0.75 to +5.25 V
0..20 mA	0.00 to +20.90 mA	+0.10 to +21.00 mA	0.00 to +21.00 mA
4..20 mA	+3.00 to +20.90 mA	+3.10 to +21.00 mA	+3.00 to +21.00 mA

•Analogue I/O unit parameters (1)

No.	Parameter (H.T. Symbol)	Definition	Item	Content	Default setting	Parameter setting	
						By PLC	By H.T.
1	The power supply short circuit detection for the input or output device (SC_MonSs)	Generates error per unit when the short circuit of the input device power supply or output device is detected.	Enable	Generates an error.	○		
			Disable	Does not generate an error.		○	○
2	Analogue input or output range (Range)	Sets the analogue input or output device range per channel.	0..10 V	Selects the analogue input or output range.	1..5 V	○	○
			0..5 V				
			1..5 V				
			0..20 mA				
			4..20 mA				
3	Analogue data format (D_Format)	Sets analogue data type which is output to PLC per unit.	Offset binary	Offset binary.	○		
			Sign & Magnitude	Signed binary.		○	○
			2S Complement	2's complement.			
			Scaled	Scale conversion type.			
4	Analogue average filter (Filter)	Sets analogue filtering time per channel. Sampling interval is approx. 2 sec.	None	None.	○		
			2AVG	2 value average.		○	○
			4AVG	4 value average.			
			8AVG	8 value average.			
5	Over range detection (Over_Rng)	Generates error per unit when the input value exceeds 0.5% of full span.	Enable	Generates an error.		○	○
			Disable	Does not generate an error.	○		
6	Under range detection (Undr_Rng)	Generates error per unit when the input value falls below 0.5% of full span.	Enable	Generates an error.		○	○
			Disable	Does not generate an error.	○		
7	User's set value upper limit error (Upr_Lmt)	Generates error per channel when the input or output value exceeds the set value.	Enable	Generates an error. *2			
			Disable	Does not generate an error.	○		
	Scale upper limit setting *1 (UpLm/Scl)	Sets the scale upper limit. Generates error per channel when the input or output value exceeds the upper limit.	Enable	Generates an error. Val: -32766 to 32767		×	○
			Disable	Does not generated an error. Val: -32766 to 32767	○ Val: 1000		

•Analogue I/O unit parameters (2)

No.	Parameter (H.T. Symbol)	Definition	Item	Content	Default setting	Parameter setting	
						By PLC	By H.T.
8	User's set value lower limit error (Lwr_Lmt)	Generates error per channel when the input or output value falls below the set value.	Enable	Generates an error. *2		x	o
			Disable	Does not generate an error.	o		
	Scale lower limit setting *1 (UpLm/Scl)	Sets the scale lower limit. Generates error per channel when the input or output value falls below the lower limit.	Enable	Generates an error. Val: -32767 to 32766			
			Disable	Does not generate an error. Val: -32767 to 32766	o Val: 0		
9	Output setting for communication fault *3 (Fault_MA)	Sets output per channel when communication is abnormal.	Enable	Val is output. *2		x	o
			Disable	The output is held.	o		
10	Output setting for communication idling *3 (Idle_MA)	Sets output per channel during communication idling.	Enable	Val is output. *2		x	o
			Disable	The output is held.	o		

*1: When "Scaled" is selected as the analogue data format, the display of H.T. is switched from Upr_Lmt to UpLm/Scl, from Lwr_Lmt to LwLm/Scl.

*2: Set value shall be set per analogue output range within settable range in the table below. When the analogue output range is changed, check the set value and change it to an appropriate value.

*3: This function is valid only when "Hold/Clear priority" of the system parameter is set to Handheld.

Analogue Input or output measurement range. (Range)	Upper and lower setting limit of user setting.		Settable range during communication error or idling. (Fault_MA) (Idle_MA)
	(Lwr_Lmt)	(Upr_Lmt)	
0..10 V	0.00 to +10.45 V	+0.05 to +10.50 V	0.00 to +10.50 V
0..5 V	0.00 to +5.22 V	+0.03 to +5.25 V	0.00 to +5.25 V
1..5 V	+0.75 to +5.22 V	+0.78 to +5.25 V	+0.75 to +5.25 V
0..20 mA	0.00 to +20.90 mA	+0.10 to +21.00 mA	0.00 to +21.00 mA
4..20 mA	+3.00 to +20.90 mA	+3.10 to +21.00 mA	+3.00 to +21.00 mA

Hardware Configuration

■ GSD file and icon

GSD file is required to configure the EX600 with a DP Master. The GSD File contains ID number, version, and unit information. Furthermore, icons are necessary for the display icon of the EX600 on the DP Master Software. The GSD File and icon can be downloaded from the URL given below.

•URL: <https://www.smcworld.com>

Products Document → Instruction Manual → SMCB1411.zip

•Content of SMCB1411.zip	GSD File	SMCB1411.gsd
	Icon	EX600_N.bmp (standard type)
		EX600_D.bmp (diagnostic type)
		EX600_S.bmp (special operating mode)

■ Configuration layout

The Unit number is sequentially allotted from the End Plate end of the EX600 assembly. The communication with the DP Master will not be established if the layout of the hardware configuration does not match the actual system configuration.

•Example of unit number.

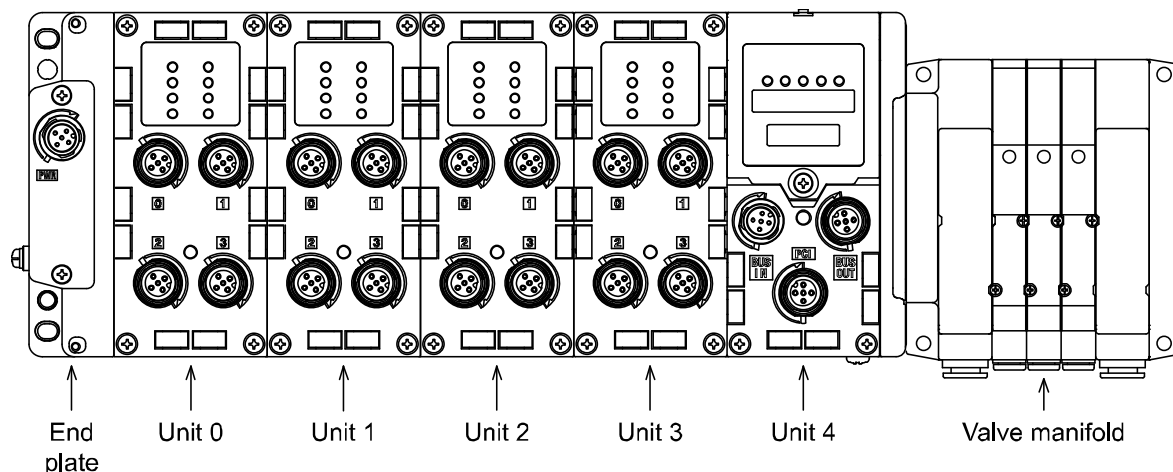

■ SIEMENS PLC S7™ connection method

Below is an explanation of the EX600 Series connection method with a SIEMENS' PLC STEP7™. Refer to the manual of STEP7™ for a detailed manner of operation.

•GSD File Installation

There are 2 methods for installing the EX600-SPR# GSD file.

•Method1: Before starting-up STEP7™.

- (1) Copy GSD file to [.../Siemens/Step7/S7data/gsd] folder.
- (2) Copy icons to [.../Siemens/Step7/S7data/nsbmp] folder.

•Method 2: After STEP7™ has been started.

- (1) Open [HW Configuration] window.
- (2) Select [Option] → [Install New GSD...] From the menu bar.
- (3) Select GSD File (SMCB1411.gsd), and click the [Open] button.

After completing the above steps, the "EX600-SPR1/2" will automatically be added to the STEP7™ [PROFIBUS DP/Additional Field Devices/I/O] Folder on [Hardware Catalogue] window.

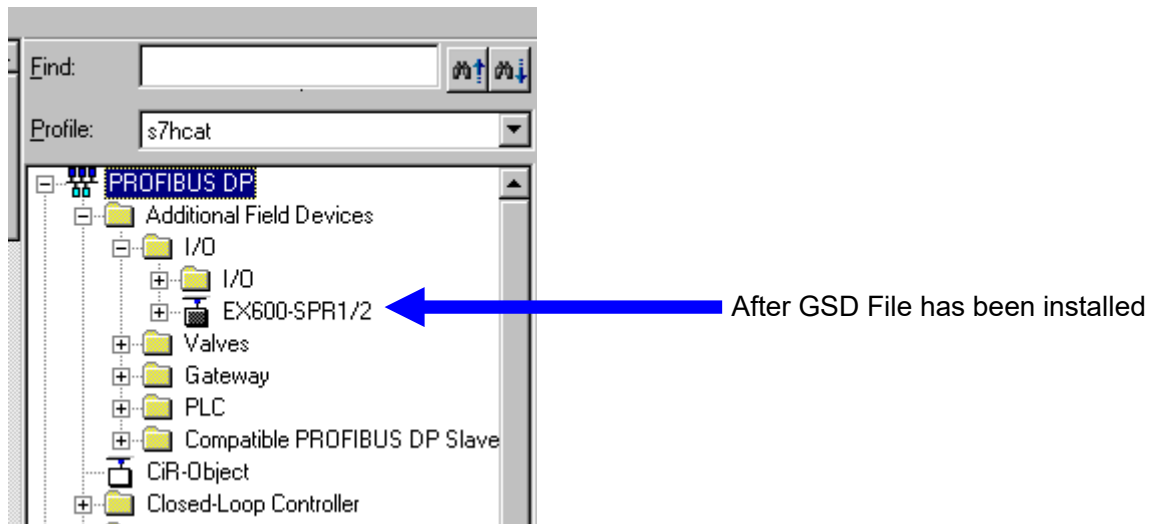

•Adding Stations

- (1) Drag and drop [EX600-SPR1/2] from [Hardware Catalogue] window to the line of [PROFIBUS: DP master system].
- (2) [Property-PROFIBUS Interface EX600-SPR1/2] window will be displayed.
- (3) Enter the unit address on the dialogue box. Please make sure that the address entered is the same as the address set, using the SI unit switches.

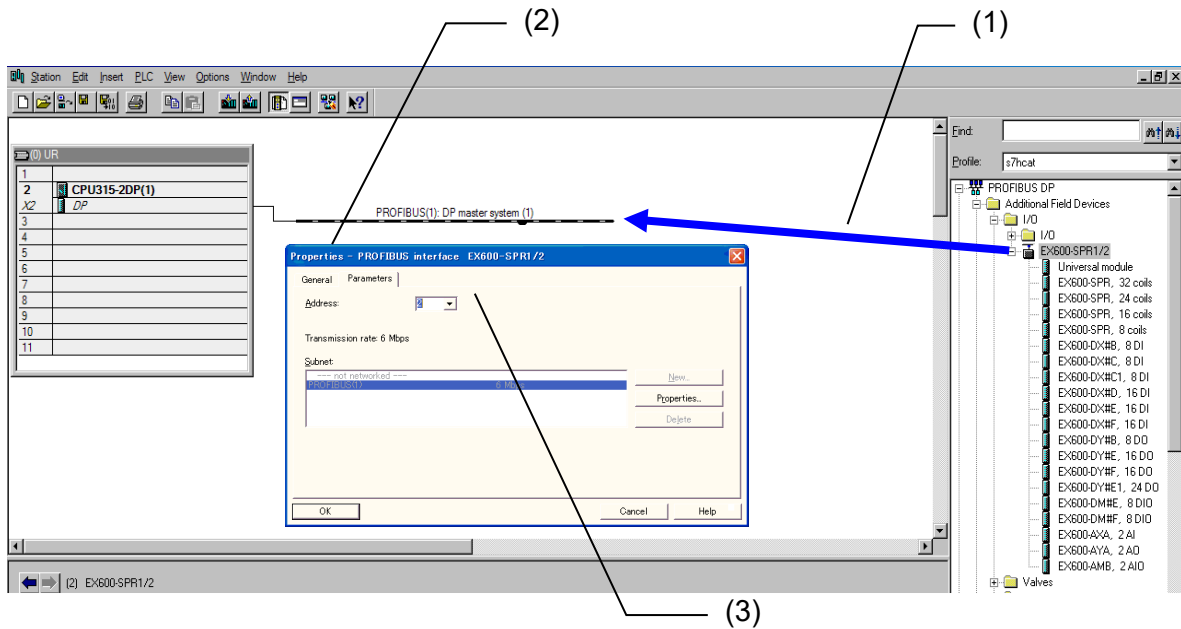

- (4) Press the [OK] button to confirm the address setting. Icon of [EX600-SPR1/2] will be shown on [station] window.

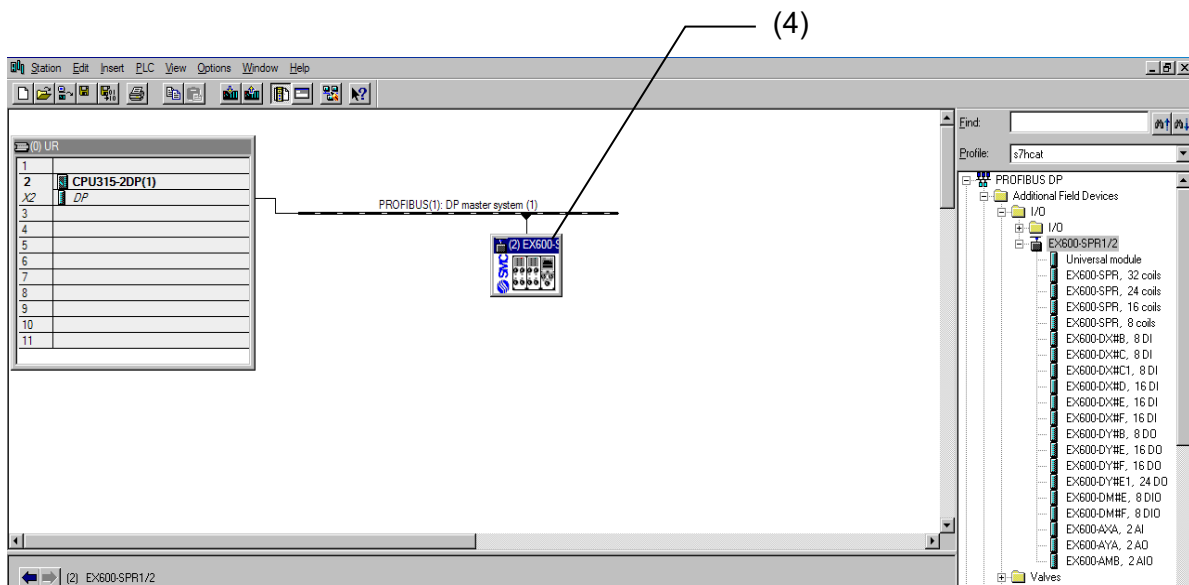

•Adding Units

- (1) Select [EX600-SPR1/2] from [station] window.
- (2) An empty slot for [EX600-SPR1/2] will be displayed on [Configuration table] window.
- (3) Drag and drop the connected unit from [Hardware Catalogue] window to slot 1. Please make sure to add the unit as the real system's order of connecting.
- (4) Add the other units, according to the connected order, to the [Configuration table] window, ending with the SI unit.
 - Unit number 0 = slot 1
 - Unit number 1 = slot 2
 - :
 - Unit number 8 = slot 9
 - Unit number 9 = slot 10
- (5) The SI Unit for 32, 24, 16, 8 coils can be selected, please make sure to match the setting with the V_SEL switch setting in the SI unit.

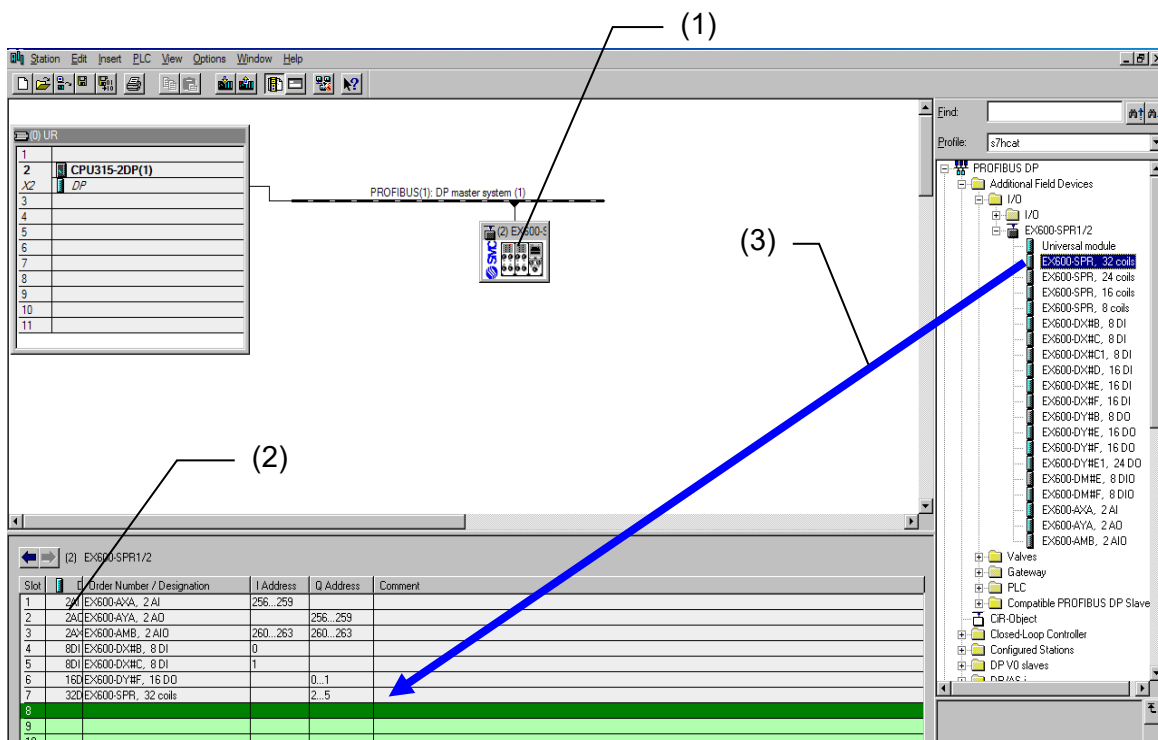

Parameter setting at PLC

System Parameter Setting

- (1) Double click the [EX600-SPR1/2] icon on the line of [PROFIBUS: DP master system]. [Properties – DP slave] window will be displayed.
- (2) Select the [Parameter Assignment] tab, the available Parameter setting list will be displayed.
- (3) Change the parameter value by clicking on the [Value] column of the selected parameter.
- (4) Press the [OK] Button, after the configuration data is downloaded to the PLC, the setting will be completed.

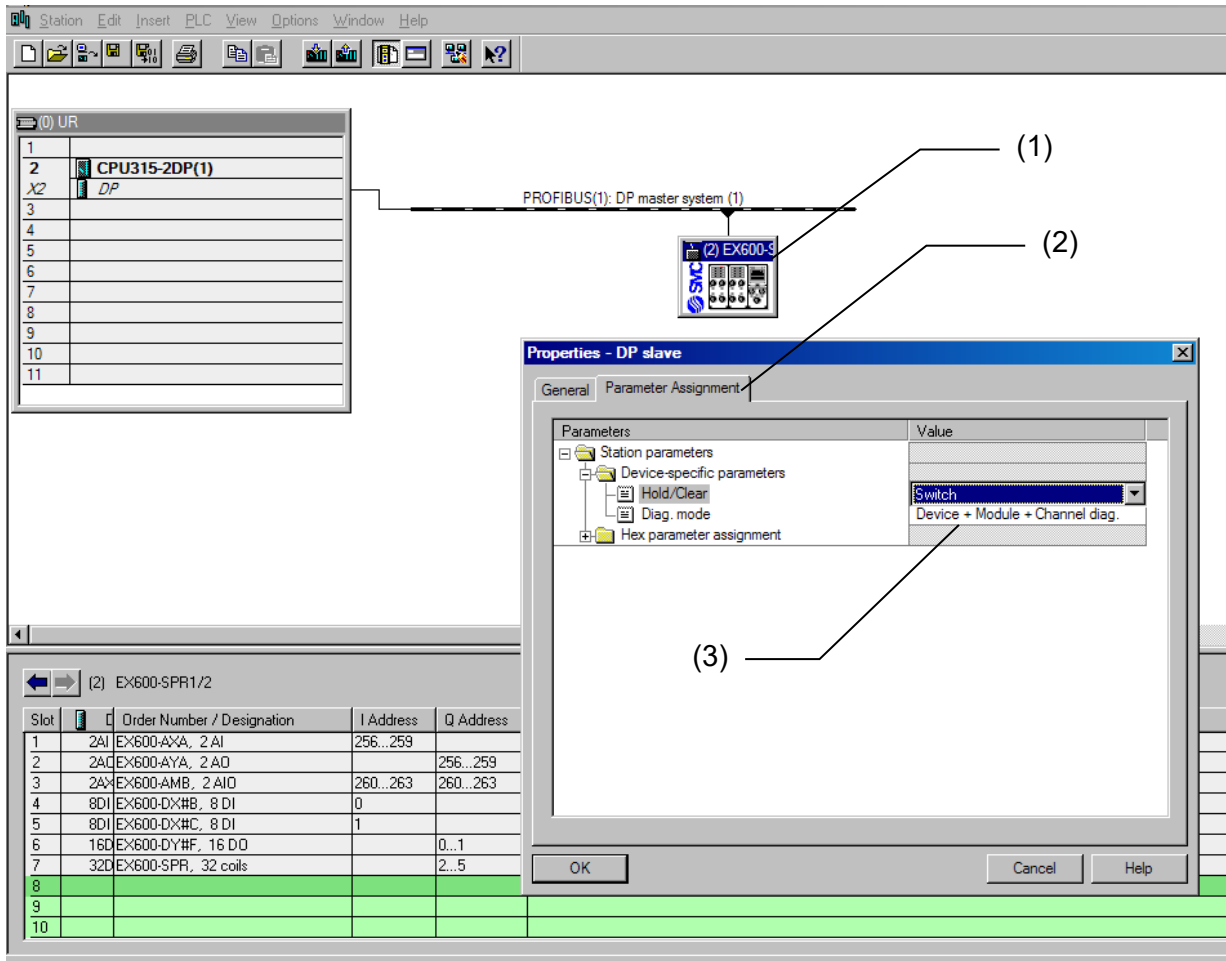

The system parameters given below can be set at the STEP7™.

System parameter	Setting value
Hold/Clear	Switch
	Handheld
Diag. mode	No diag.
	Device diag.
	Device + Module diag.
	Device + Module + Channel diag.

•Unit Parameter Setting

- (1) Double click a unit that you want to set on the [Configuration table] window. [Properties – DP slave] window will be displayed.
- (2) Select the [Parameter Assignment] tab, the available Parameter setting list will be displayed.
- (3) Change the parameter value by clicking on the [Value] column of the selected parameter.
- (4) Press the [OK] Button, after the configuration data is downloaded to the PLC, the setting will be completed.

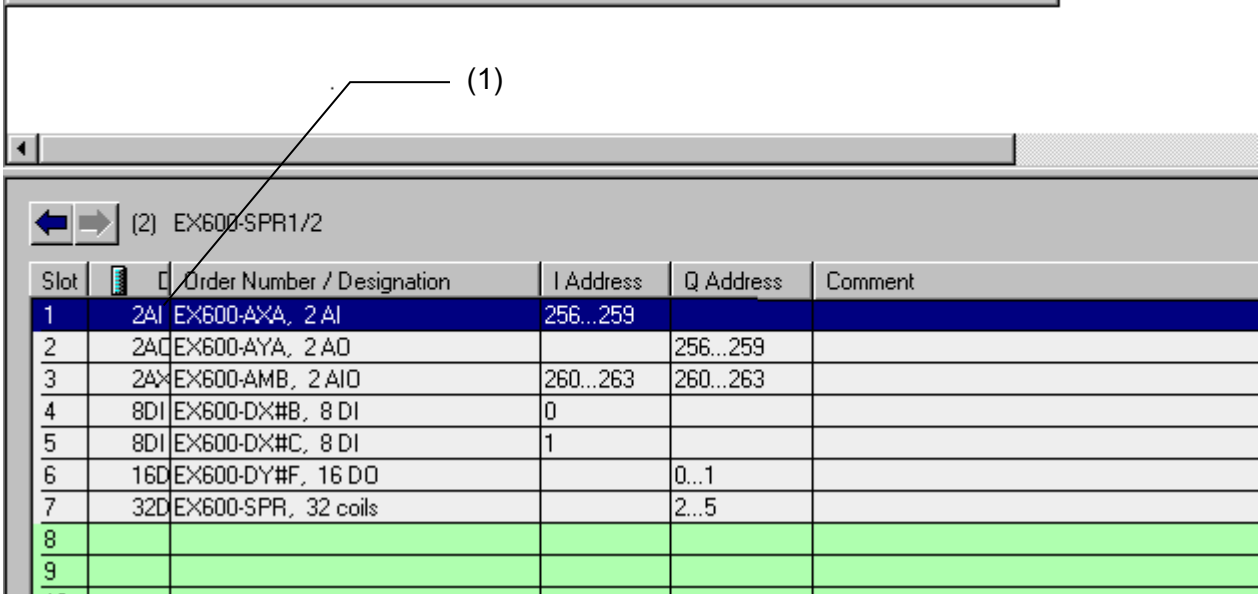
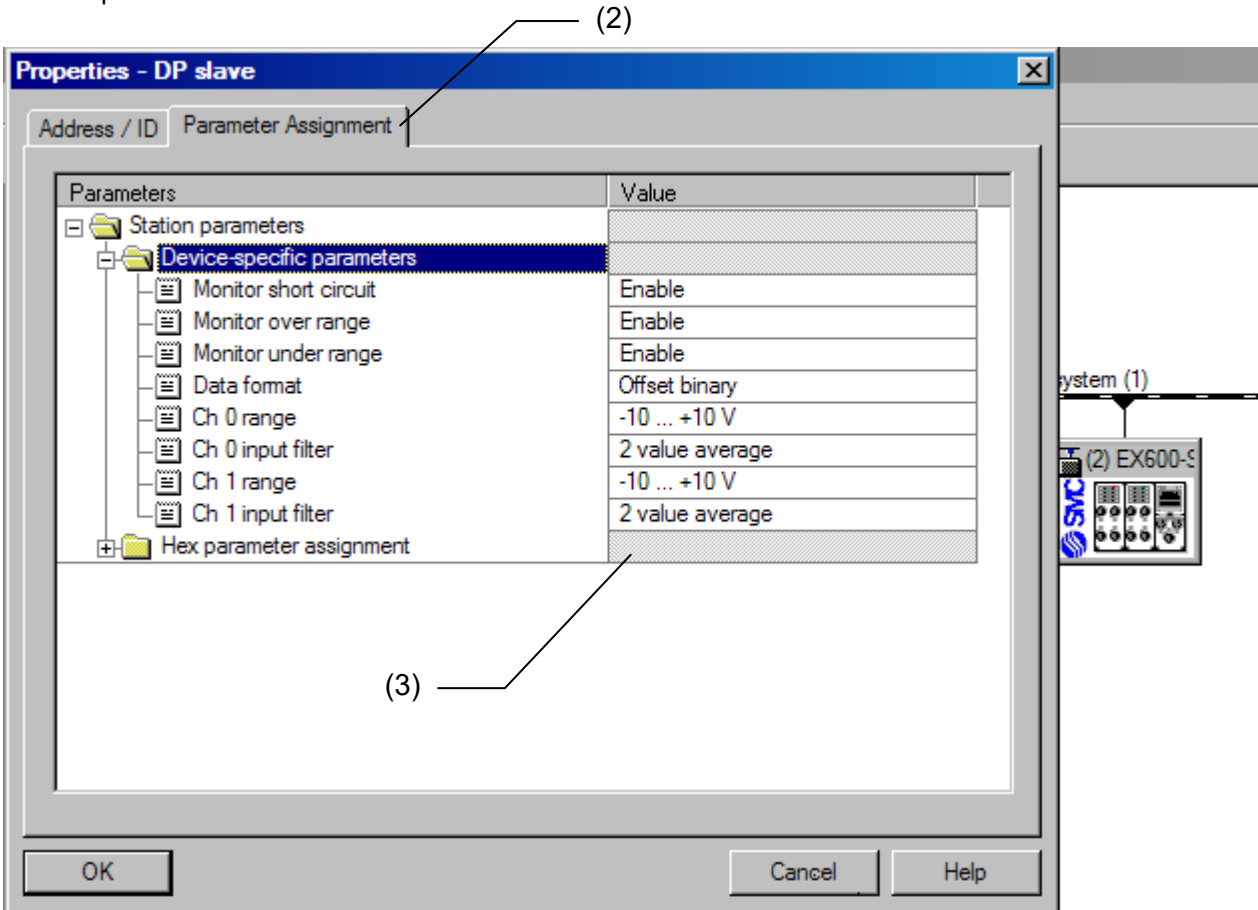

*: Screen data used on this document is taken from STEP7™ software by Siemens AG.

I/O Map

Each unit of the product has its own identification (ID) number.

Unit	Unit part number	Occupied byte		ID number	
		Input	Output	Siemens	IEC61158
SI unit	EX600-SPR#A (32 outputs)	0	4	32DO	23h
	EX600-SPR#A (24 outputs)	0	3	24DO	22h
	EX600-SPR#A (16 outputs)	0	2	16DO	21h
	EX600-SPR#A (8 outputs)	0	1	8DO	20h
Digital input unit	EX600-DX#B (8 inputs)	1	0	8DI	10h
	EX600-DX#C (8 inputs)	1	0	8DI	10h
	EX600-DX#C1 (8 inputs) (with open circuit detection)	1	0	8DI	10h
	EX600-DX#D (16 inputs)	2	0	16DI	11h
	EX600-DX#E (16 inputs)	2	0	16DI	11h
	EX600-DX#F (16 inputs)	2	0	16DI	11h
Digital output unit	EX600-DY#B (8 outputs)	0	1	8DO	20h
	EX600-DY#E (16 outputs)	0	2	16DO	21h
	EX600-DY#E1 (24 outputs)	0	3	24DO	22h
	EX600-DY#F (16 outputs)	0	2	16DO	21h
Digital I/O unit	EX600-DM#E (8 inputs/8 output)	1	1	8DX	30h
	EX600-DM#F (8 inputs/8 output)	1	1	8DX	30h
Analogue input unit	EX600-AXA (2 channels)	4 (2 byte/1 channel)	0	2AI	51h
Analogue output unit	EX600-AYA (2 channels)	0	4 (2 byte/1 channel)	2AO	61h
Analogue I/O unit	EX600-AMB (2 channels)	4 (2 byte/1 channel)	4 (2 byte/1 channel)	2AX	71h

Diagnostic

The diagnosis mode is set by the system parameter "Diag. mode". (Refer to "System parameters" (page 53) for details.)

No.	Diagnostic Mode	Content
1	No diag.	Outputs the standard diagnosis information.
2	Device diag.	Outputs the standard and system diagnosis information.
3	Device + Module diag.	Outputs the standard, system and unit diagnosis information.
4	Device + Module + Channel Diag.	Outputs the standard, system, unit and channel diagnosis information.

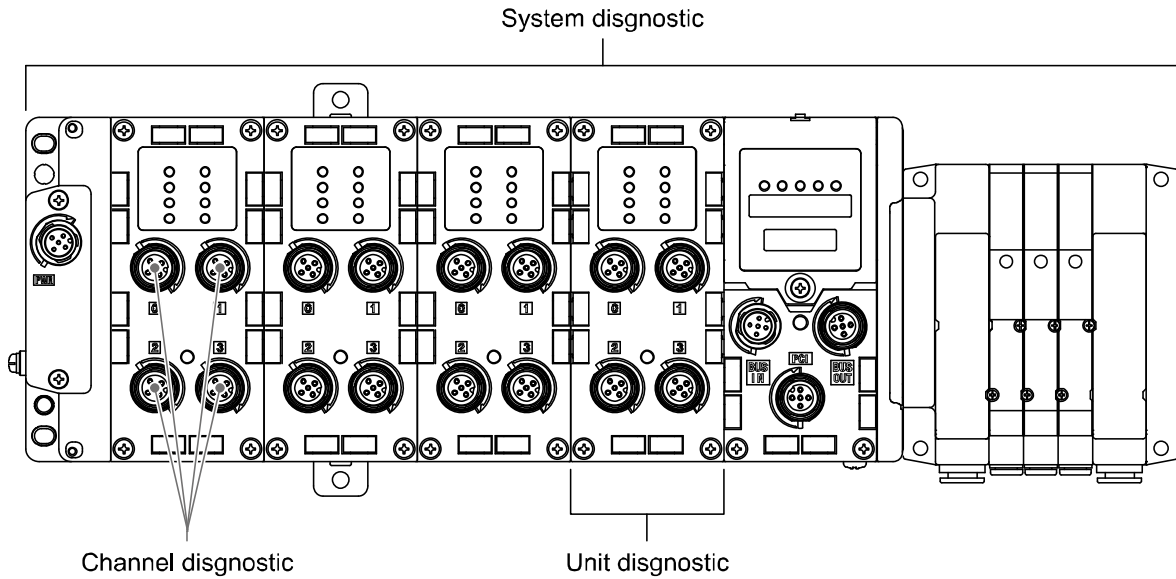

•Diagnosis map

Byte No.	Content	Diagnostic type
Byte 0	Station status 1	Standard diagnostic data
Byte 1	Station status 2	
Byte 2	Station status 3	
Byte 3	Master PROFIBUS DP address	
Byte 4	Manufacturer ID (MSB: 14h)	
Byte 5	Manufacturer ID (LSB: 11h)	
Byte 6	Header	System diagnostic data
Byte 7	System diag.1	
Byte 8	System diag.2	
Byte 9	System diag.3	
Byte 10	System diag.4	
Byte 11	Reserved	
:	:	
Byte 18	Reserved	Unit diagnostic data
Byte 19	Header	
Byte 20	Unit 0 to 7	
Byte 21	Unit 8 to 9	
Byte 22	Reserved	
:	:	
Byte 27	Reserved	Channel diagnostic data
Byte 28	Unit A	
Byte 29	Channel A	
Byte 30	Diagnostic contents A	
Byte 31	Unit B	
Byte 32	Channel B	
Byte 33	Diagnostic contents B	
:	:	
Byte 61	Unit L	
Byte 62	Channel L	
Byte 63	Diagnostic contents L	

•Standard diagnostic data

•Station status 1

	7	6	5	4	3	2	1	0
Byte 0			0					

Bit No.	Content
0	1: The slave cannot be accessed by the master.
1	1: The slave is not ready to exchange data.
2	1: The configuration data sent from the master to the slave is not consistent with the setting of the slave.
3	1: The external diagnosis is available.
4	1: The necessary function is not supported by the slave.
5	(This bit is fixed to 0.)
6	1: The slave type is not covered by the configuration of the software.
7	1: The parameter is assigned to the slave by a different master.

•Station status 2

	7	6	5	4	3	2	1	0
Byte 1		0				1		

Bit No.	Content
0	1: The new parameter needs to be assigned to a slave.
1	1: The new message has been issued.
2	(This bit is fixed to 1.)
3	1: The response monitor is enabled to the slave.
4	1: The slave has received the FREEZE control command.
5	1: The slave has received the SYNC control command.
6	(This bit is fixed to 0.)
7	1: The slave is disabled.

•Station status 3

	7	6	5	4	3	2	1	0
Byte 2		0	0	0	0	0	0	0

Bit No.	Content
0 to 6	(This bit is fixed to 0)
7	1: The number of diagnosis messages has exceeded the capacity of the slave.

•Master PROFIBUS Address

Byte 3 shows a PROFIBUS address of the master in which the parameter of the slave can be changed. When the address is FFh, the parameter of the slave cannot be changed.

•Slave ID

Byte 4 and 5 show a slave ID. The ID of EX600-SPR#A is 1411h.

•System diagnostic data

•Header

	7	6	5	4	3	2	1	0
Byte 6	0	0	0	0	1	1	0	1

Bit No.	Content
0 to 7	0Eh: The number of bytes of the system diagnosis information (fixed to 13 bytes).

•System diag.1

	7	6	5	4	3	2	1	0
Byte 7								

Bit No.	Content
0	1: The analogue input or output value has fallen below the user's set value.
1	1: The analogue input or output value has exceeded the user's set value.
2	1: The analogue input value has fallen below the set range.
3	1: The analogue input value has exceeded the set range.
4	1: The counter has exceeded the set value.
5	1: The open circuit has been detected.
6	1: The short circuit of the valve output or digital output has been detected.
7	1: The short circuit of the power supply for the input device has been detected.

•System diag.2

	7	6	5	4	3	2	1	0
Byte 8			-			-		

Bit No.	Content
0	1: The power supply for output device is outside of the specification.
1	1: The power supply for control and input device is outside of the specification.
2	Reserved
3	1: There is a connection failure between each unit (during operation).
4	1: There is a connection failure between each unit (when the power supply is applied).
5	Reserved
6	1: System error occurred.
7	1: Hardware error occurred.

•System diag.3

	7	6	5	4	3	2	1	0
Byte 9	-	-	-	-	-	-	-	-

Bit No.	Content
0 to 7	Reserved

•System diag.4

	7	6	5	4	3	2	1	0
Byte 10	-	-	-					

Bit No.	Content
0	1: There is an error in the digital input unit.
1	1: There is an error in the digital output unit.
2	1: There is an error in the analogue input unit.
3	1: There is an error in the analogue output unit.
4	1: There is an error in the SI unit.
5	Reserved
6	Reserved
7	Reserved

•Unit standard diagnostic data

•Header

	7	6	5	4	3	2	1	0
Byte 19	0	1	0	0	1	0	0	1

Bit No.	Content
0 to 5	09h: The number of bytes of the unit diagnosis information (fixed to 9 bytes).
6	(This bit is fixed to 1)
7	(This bit is fixed to 0)

•Unit 0 to 7

	7	6	5	4	3	2	1	0
Byte 20								

Bit No.	Content
0	1: There is an error in unit 0.
1	1: There is an error in unit 1.
2	1: There is an error in unit 2.
3	1: There is an error in unit 3.
4	1: There is an error in unit 4.
5	1: There is an error in unit 5.
6	1: There is an error in unit 6.
7	1: There is an error in unit 7.

•Unit 8 to 9

	7	6	5	4	3	2	1	0
Byte 21	-	-	-	-	-	-		

Bit No.	Content
0	1: There is an error in unit 8.
1	1: There is an error in unit 9.
2	Reserved
3	Reserved
4	Reserved
5	Reserved
6	Reserved
7	Reserved

•Channel diagnostic data

The channel diagnosis information is 3 bytes, and handles a maximum of 12 errors.

However, each unit can output only 1 error, and will output the error with a smaller channel number when it multiple errors have been generated.

	7	6	5	4	3	2	1	0	
Byte 28	1	0	-						Unit number
Byte 29									Channel number
Byte 30									Diagnosis type
⋮									
	7	6	5	4	3	2	1	0	
Byte 61	1	0	-						Unit number
Byte 62									Channel number
Byte 63									Diagnosis type

•Unit number

Bit No.	Content
0 to 4	A unit number of 0 to 9 is displayed.
5	Reserved
6	(This bit is fixed to 0)
7	(This bit is fixed to 1)

•Channel number

Bit No.	Content
0 to 5	A channel number of 0 to 63 is displayed.
6	Input/Output Type: 00 = Reserved, 01 = Input, 10 = Output
7	

•Diagnostic type

Bit No.	Content
0 to 4	Error code
5	Channel type: 001 = Bit (Unit other than analogue unit), 101 = Word (Analogue unit)
6	
7	

•Error code

Error code		Content	Level *1
Binary	Decimal		
00000	0	Reserved	
00001	1	The short circuit has been detected.	3
00010	2	Reserved	
:	:	:	
00101	5	Reserved	
00110	6	The open circuit has been detected.	3
00111	7	The analogue input value has exceeded the set range.	3
01000	8	The analogue input value has fallen below the set range.	3
01001	9	Reserved	
:	:	:	
01111	15	Reserved	
10000	16	The analogue input or output value has exceeded the upper limit of the user's set value.	3
10001	17	The analogue input or output value has fallen below the lower limit of the user's set value.	3
10010	18	The counter has exceeded the set value.	3
10011	19	Reserved	
:	:	:	
11101	29	Reserved	
11110	30	There is a connection failure between each unit.	1
11111	31 *2	There is a hardware error.	2

*1: If multiple errors have occurred in the same channel of the same unit, they will be given priority in order of level (1→2→3).

*2: The channel number when an error has occurred is 0.

Accessories

For the selection of accessories, refer to the catalog.

(1) Valve plate

EX600-ZMV1

Enclosed parts: Round head screw (M4 x 6), 2 pcs.
Round head screw (M3 x 8), 4 pcs.

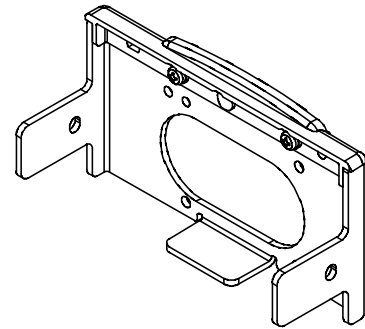

EX600-ZMV2 (Specified for SY series)

Enclosed parts: Round head screw (M4 x 6), 2 pcs.
Round head screw (M3 x 8), 4 pcs.

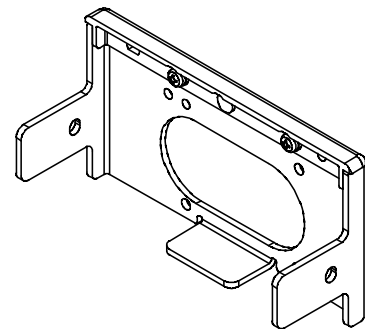

(2) End plate bracket

EX600-ZMA2

Enclosed parts: Round head screw (M4 x 20), 1 pc.
P tithe screw (4 x 14), 2 pcs.

EX600-ZMA3 (Specified for SY series)

Enclosed parts: Round head screw (M4 x 20) with washer, 1 pc.
P tithe screw (4 x 14), 2 pcs.

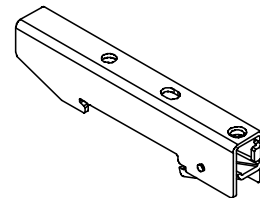

(3) Intermediate support bracket

EX600-ZMB1...for direct mounting

Enclosed parts: Round head screw (M4 x 5), 2 pcs.

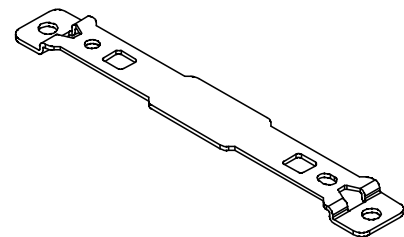

EX600-ZMB2...for DIN rail mounting

Enclosed parts: Round head screw (M4 x 6), 2 pcs.

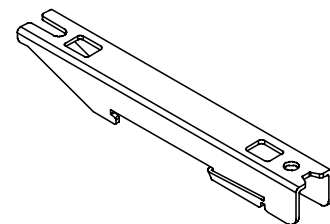

- (4) Seal cap (10 pcs.)
EX9-AWES...for M8
EX9-AWTS...for M12

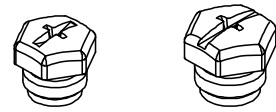

- (5) Marker (1 sheet, 88 pcs.)
EX600-ZT1



- (6) Y Junction connector
PCA-1557785 2 x M12 (3-pin) – M12 (5-pin)

- (7) Assembled type connector
PCA-1578078 for power supply, 7/8 inch, Plug, Cable O.D. 12 to 14 mm
PCA-1578081 for power supply, 7/8 inch, Socket, Cable O.D. 12 to 14 mm
PCA-1075530 PROFIBUS DP communication, Plug, SPEEDCON compatible
PCA-1075531 PROFIBUS DP communication, Socket, SPEEDCON compatible
PCA-1557730 M8 (3-pin), plug
PCA-1557743 M12 (4-pin), plug, for AWG26 to AWG22, SPEEDCON compatible
PCA-1557756 M12 (4-pin), plug, for AWG22 to AWG18, SPEEDCON compatible

- (8) Power supply cable
PCA-1558810 Cable with 7/8 inch connector, Socket, Straight 2 m
PCA-1558823 Cable with 7/8 inch connector, Socket, Straight 6 m
PCA-1558836 Cable with 7/8 inch connector, Socket, Right angle 2 m
PCA-1558849 Cable with 7/8 inch connector, Socket, Right angle 6 m
PCA-1564927 Cable with M12 connector, B-coded, Socket, Straight 2 m, SPEEDOCON compatible
PCA-1564930 Cable with M12 connector, B-coded, Socket, Straight 6 m, SPEEDOCON compatible
PCA-1564943 Cable with M12 connector, B-coded, Socket, Right angle 2 m, SPEEDOCON compatible
PCA-1564969 Cable with M12 connector, B-coded, Socket, Right angle 6 m, SPEEDOCON compatible
PCA-1401804 Cable with M12 connector, A-coded, Socket, Straight 1.5 m, SPEEDOCON compatible
PCA-1401805 Cable with M12 connector, A-coded, Socket, Straight 3 m, SPEEDOCON compatible
PCA-1401806 Cable with M12 connector, A-coded, Socket, Straight 5 m, SPEEDOCON compatible
EX500-AP010-S Cable with M12 connector, A-coded, Socket, Straight 1 m
EX500-AP050-S Cable with M12 connector, A-coded, Socket, Straight 5 m
EX500-AP010-A Cable with M12 connector, A-coded, Socket, Right angle 1 m
EX500-AP050-A Cable with M12 connector, A-coded, Socket, Right angle 5 m
PCA-1557769 Cable with M12 connector, A-coded, Socket/Plug, Straight 3 m, SPEEDOCON compatible

- (9) PROFIBUS DP communication cable
PCA-1557688 Cable with M12 connector, B-coded, Socket, Straight 5 m, SPEEDOCON compatible
PCA-1557691 Cable with M12 connector, B-coded, Plug, Straight 5 m, SPEEDOCON compatible

- (10) Connector extension cable
PCA-1557769 M12 (4-pin), Straight 3 m
PCA-1557772 M8 (3-pin), Straight 3 m

Revision history

- A: Revision (Pollution degree)
- B: Contents revised in several places.
- C: Contents revised in several places.
[February 2022]
- D: Contents revised in several places.
[January 2024]
- E: Contents revised in several places [May 2024]

SMC Corporation

Tel: + 81 3 5207 8249 Fax: +81 3 5298 5362

URL <https://www.smcworld.com>

Note: Specifications are subject to change without prior notice and any obligation on the part of the manufacturer.

© SMC Corporation All Rights Reserved

