



# Operation Manual

## PRODUCT NAME

Fieldbus system  
CC-Link compatible SI unit

## MODEL / Series / Product Number

*EX600-SMJ#*  
*EX600-ED#*

**SMC Corporation**

## Table of Contents

|                                   |    |
|-----------------------------------|----|
| Safety Instructions               | 2  |
| System Outline                    | 8  |
| Definition and terminology        | 9  |
| Assembly                          | 11 |
| Basic precautions                 | 11 |
| Mounting and Installation         | 14 |
| Installation                      | 14 |
| Wiring                            | 16 |
| <b>SI Unit</b>                    |    |
| Model Indication and How to Order | 17 |
| Summary of Product parts          | 17 |
| Mounting and Installation         | 18 |
| Wiring                            | 18 |
| Setting and Adjustment            | 19 |
| LED Display                       | 25 |
| Specification                     | 27 |
| Specifications                    | 27 |
| Dimensions                        | 28 |
| <b>End plate</b>                  |    |
| Model Indication and How to Order | 29 |
| Summary of Product parts          | 29 |
| Mounting and Installation         | 30 |
| Wiring                            | 30 |
| Specification                     | 31 |
| Specifications                    | 31 |
| Dimensions                        | 31 |
| Maintenance                       | 33 |
| Troubleshooting                   | 34 |
| Parameter Setting                 | 44 |
| Parameter definition and setting  | 44 |
| I/O Map                           | 57 |
| Diagnostic                        | 59 |
| Details of diagnostic data        | 60 |
| Accessories                       | 64 |



# Safety Instructions

These safety instructions are intended to prevent hazardous situations and/or equipment damage. These instructions indicate the level of potential hazard with the labels of “**Caution**,” “**Warning**” or “**Danger**.” They are all important notes for safety and must be followed in addition to International Standards (ISO/IEC)<sup>\*)</sup>, and other safety regulations.

\*1) ISO 4414: Pneumatic fluid power - General rules and safety requirements for systems and their components  
ISO 4413: Hydraulic fluid power - General rules and safety requirements for systems and their components  
IEC 60204-1: Safety of machinery - Electrical equipment of machines - Part 1: General requirements  
ISO 10218-1: Robots and robotic devices - Safety requirements for industrial robots - Part 1: Robots  
etc.



## **Danger**

**Danger** indicates a hazard with a high level of risk which, if not avoided, will result in death or serious injury.



## **Warning**

**Warning** indicates a hazard with a medium level of risk which, if not avoided, could result in death or serious injury.



## **Caution**

**Caution** indicates a hazard with a low level of risk which, if not avoided, could result in minor or moderate injury.

## **Warning**

### **1. The compatibility of the product is the responsibility of the person who designs the equipment or decides its specifications.**

Since the product specified here is used under various operating conditions, its compatibility with specific equipment must be decided by the person who designs the equipment or decides its specifications based on necessary analysis and test results. The expected performance and safety assurance of the equipment will be the responsibility of the person who has determined its compatibility with the product. This person should also continuously review all specifications of the product referring to its latest catalog information, with a view to giving due consideration to any possibility of equipment failure when configuring the equipment.

### **2. Only personnel with appropriate training should operate machinery and equipment.**

The product specified here may become unsafe if handled incorrectly. The assembly, operation and maintenance of machines or equipment including our products must be performed by an operator who is appropriately trained and experienced.

### **3. Do not service or attempt to remove product and machinery/equipment until safety is confirmed.**

1. The inspection and maintenance of machinery/equipment should only be performed after measures to prevent falling or runaway of the driven objects have been confirmed.
2. When the product is to be removed, confirm that the safety measures as mentioned above are implemented and the power from any appropriate source is cut, and read and understand the specific product precautions of all relevant products carefully.
3. Before machinery/equipment is restarted, take measures to prevent unexpected operation and malfunction.

### **4. Our products cannot be used beyond their specifications. Our products are not developed, designed, and manufactured to be used under the following conditions or environments. Use under such conditions or environments is not covered.**

1. Conditions and environments outside of the given specifications, or use outdoors or in a place exposed to direct sunlight.
2. Use for nuclear power, railways, aviation, space equipment, ships, vehicles, military application, equipment affecting human life, body, and property, fuel equipment, entertainment equipment, emergency shut-off circuits, press clutches, brake circuits, safety equipment, etc., and use for applications that do not conform to standard specifications such as catalogs and operation manuals.
3. Use for interlock circuits, except for use with double interlock such as installing a mechanical protection function in case of failure. Please periodically inspect the product to confirm that the product is operating properly.



# Safety Instructions

## Caution

**We develop, design, and manufacture our products to be used for automatic control equipment, and provide them for peaceful use in manufacturing industries.**

**Use in non-manufacturing industries is not covered.**

Products we manufacture and sell cannot be used for the purpose of transactions or certification specified in the Measurement Act.

The new Measurement Act prohibits use of any unit other than SI units in Japan.

## Limited warranty and Disclaimer/Compliance Requirements

The product used is subject to the following “Limited warranty and Disclaimer” and “Compliance Requirements”.

Read and accept them before using the product.

### Limited warranty and Disclaimer

1. The warranty period of the product is 1 year in service or 1.5 years after the product is delivered, whichever is first.\*2)

Also, the product may have specified durability, running distance or replacement parts. Please consult your nearest sales branch.

2. For any failure or damage reported within the warranty period which is clearly our responsibility, a replacement product or necessary parts will be provided.

This limited warranty applies only to our product independently, and not to any other damage incurred due to the failure of the product.

3. Prior to using SMC products, please read and understand the warranty terms and disclaimers noted in the specified catalog for the particular products.

**\*2) Vacuum pads are excluded from this 1 year warranty.**

A vacuum pad is a consumable part, so it is warranted for a year after it is delivered.

Also, even within the warranty period, the wear of a product due to the use of the vacuum pad or failure due to the deterioration of rubber material are not covered by the limited warranty

### Compliance Requirements

1. The use of SMC products with production equipment for the manufacture of weapons of mass destruction (WMD) or any other weapon is strictly prohibited.

2. The exports of SMC products or technology from one country to another are governed by the relevant security laws and regulations of the countries involved in the transaction. Prior to the shipment of a SMC product to another country, assure that all local rules governing that export are known and followed.

## Operator

- ◆ This operation manual is intended for those who have knowledge of machinery using pneumatic equipment, and have sufficient knowledge of assembly, operation and maintenance of such equipment. Only those persons are allowed to perform assembly, operation and maintenance.
- ◆ Read and understand this operation manual carefully before assembling, operating or providing maintenance to the product.

### ■ Precautions

#### **Warning**

- Do not disassemble, modify (including changing the printed circuit board) or repair.  
An injury or failure can result.
- Do not operate or set with wet hands.  
This may lead to an electric shock.
- Do not operate the product outside of the specifications.  
Do not use for flammable or harmful fluids.  
Fire, malfunction, or damage to the product can result.  
Verify the specifications before use.
- Do not operate in an atmosphere containing flammable or explosive gases.  
Fire or an explosion can result.  
This product is not designed to be explosion proof.
- If using the product in an interlocking circuit:
  - Provide a double interlocking system, for example a mechanical system.
  - Check the product regularly for proper operation.Otherwise malfunction can result, causing an accident.
- The following instructions must be followed during maintenance:
  - Turn off the power supply.
  - Stop the air supply, exhaust the residual pressure and verify that the air is released before performing maintenance.Otherwise an injury can result.

## **Caution**

- When handling the unit or assembling/replacing units:
  - Do not touch the sharp metal parts of the connector or plug for connecting units.
  - Take care not to hit your hand when disassembling the unit.  
The connecting portions of the unit are firmly joined with seals.
  - When joining units, take care not to get fingers caught between units.  
An injury can result.
- After maintenance is complete, perform appropriate functional inspections.  
Stop operation if the equipment does not function properly.  
Safety cannot be assured in the case of unexpected malfunction.
- Provide grounding to assure the safety and noise resistance of the Fieldbus system.  
Individual grounding should be provided close to the product with a short cable.

### ■ NOTE

- Follow the instructions given below when designing, selecting and handling the product.
- The instructions on design and selection (installation, wiring, environment, adjustment, operation, maintenance, etc.) described below must also be followed.
  - \* Product specifications
    - When conformity to UL is required, the SI unit should be used with a UL1310 Class 2 power supply.
    - Use the specified voltage.  
Otherwise failure or malfunction can result.
    - The power supply for the unit should be 0 V as the standard for both the power supply for outputs and the power supply for inputs and control.

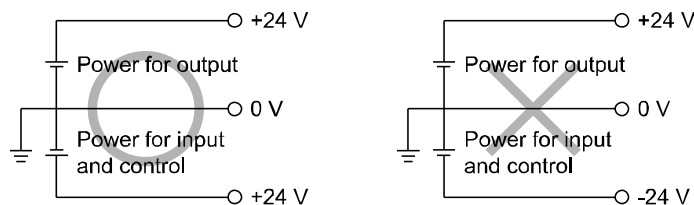

- Reserve a space for maintenance.  
Allow sufficient space for maintenance when designing the system.
- Do not remove any nameplates or labels.  
This can lead to incorrect maintenance, or misreading of the operation manual, which could cause damage or malfunction to the product.  
It may also result in non-conformity to safety standards.
- Beware of inrush current when the power supply is turned on.  
Some connected loads can apply an initial charge current which will activate the over current protection function, causing the unit to malfunction.

## ●Product handling

### \*Installation

- Do not drop, hit or apply excessive shock to the SI unit.  
Otherwise damage to the product can result, causing malfunction.
- Tighten to the specified tightening torque.  
If the tightening torque is exceeded the mounting screws may be broken.  
IP67 protection cannot be guaranteed if the screws are not tightened to the specified torque.
- If a large manifold valve is mounted, lift the unit so that stress is not applied to the connecting part while transporting.  
The stress may cause breakage of the connecting part. The unit may become very heavy depending on the combination. Transportation/installation shall be performed by multiple operators.
- Never mount a product in a location that will be used as a foothold.  
The product may be damaged if excessive force is applied by stepping or climbing onto it.

### \*Wiring

- Avoid repeatedly bending or stretching the cables, or placing heavy load on them.  
Repetitive bending stress or tensile stress can cause breakage of the cable.
- Wire correctly.  
Incorrect wiring can break the product.
- Do not perform wiring while the power is on.  
Otherwise damage to the SI unit and/or input or output device can result, causing malfunction.
- Do not route wires and cables together with power or high voltage cables.  
Otherwise the SI unit and/or input or output device can malfunction due to interference of noise and surge voltage from power and high voltage cables to the signal line.  
Route the wires (piping) of the SI unit and/or input or output device separately from power or high voltage cables.
- Confirm proper insulation of wiring.  
Poor insulation (interference from another circuit, poor insulation between terminals, etc.) can lead to excess voltage or current being applied to the product, causing damage.
- Take appropriate measures against noise, such as using a noise filter, when the Fieldbus system is incorporated into equipment.  
Otherwise noise can cause malfunction.

### \*Environment

- Select the proper type of protection according to the environment of operation.  
IP67 protection is achieved when the following conditions are met.
  - (1)The units are connected properly with fieldbus cable with M12 connector and power cable with M12 (M8) connector.
  - (2)Suitable mounting of each unit and manifold valve.
  - (3)Be sure to fit a waterproof cap on any unused connectors.  
If using in an environment that is exposed to water splashes, please take measures such as using a cover.  
Do not use in an environment where moisture or water vapor are present. Otherwise failure and malfunction can result.
- Do not use in a place where the product could be splashed by oil or chemicals.  
If the product is to be used in an environment containing oils or chemicals such as coolant or cleaning solvent, even for a short time, it may be adversely affected (damage, malfunction etc.).
- Do not use the product in an environment where corrosive gases or fluids could be splashed.  
Otherwise damage to the product and malfunction can result.
- Do not use in an area where surges are generated.  
If there is equipment generating large surge near the unit (magnetic type lifter, high frequency inductive furnace, welding machine, motor, etc.), this can cause deterioration of the internal circuitry element of the unit or result in damage. Take measures against the surge sources, and prevent the lines from coming into close contact.

- When a surge-generating load such as a relay, valve or lamp is driven directly, use a product with a built-in surge absorbing element.  
Direct drive of a load generating surge voltage can damage the unit.
- The product is CE/UKCA marked, but not immune to lightning strikes. Take measures against lightning strikes in the system.
- Prevent foreign matter such as dust or wire debris from getting inside the product.
- Mount the product in a place that is not exposed to vibration or impact.  
Otherwise failure or malfunction can result.
- Do not use the product in an environment that is exposed to temperature cycle.  
Heat cycles other than ordinary changes in temperature can adversely affect the inside of the product.
- Do not expose the product to direct sunlight.  
If using in a location directly exposed to sunlight, shade the product from the sunlight.  
Otherwise failure or malfunction can result.
- Keep within the specified ambient temperature range.  
Otherwise malfunction can result.
- Do not operate close to a heat source, or in a location exposed to radiant heat.  
Otherwise malfunction can result.

\*Adjustment and Operation

- Set the switches by using a sharp-pointed screwdriver etc. When setting the switch, do not touch other unrelated parts.  
This can cause parts damage or malfunction due to a short circuit.
- Perform settings suitable for the operating conditions.  
Incorrect setting can cause operation failure.  
(Refer to page 19 "Setting and Adjustment".)
- Please refer to the PLC manufacturer's manual etc. for details of programming and addresses.  
For the PLC protocol and programming refer to the relevant manufacturer's documentation.

\*Maintenance

- Turn off the power supply, stop the supplied air, exhaust the residual pressure and verify the release of air before performing maintenance.  
There is a risk of unexpected malfunction.
- Perform regular maintenance and inspections.  
There is a risk of unexpected malfunction.
- After maintenance is complete, perform appropriate functional inspections.  
Stop operation if the equipment does not function properly.  
Otherwise safety is not assured due to an unexpected malfunction or incorrect operation.
- Do not use solvents such as benzene, thinner etc. to clean each unit.  
They could damage the surface of the body and erase the markings on the body.  
Use a soft cloth to remove stains.  
For heavy stains, use a cloth soaked with diluted neutral detergent and fully squeezed, then wipe up the stains again with a dry cloth.



## System Outline

### •System configuration

The EX600 range of units can be connected to various types of Fieldbus to realize the reduction of input or output device wiring and the distributed control system. The unit communicates with the Fieldbus through the SI unit. One SI unit can be connected with manifold valves with up to 32 outputs and the input • output • I/O units with maximum 10 units.

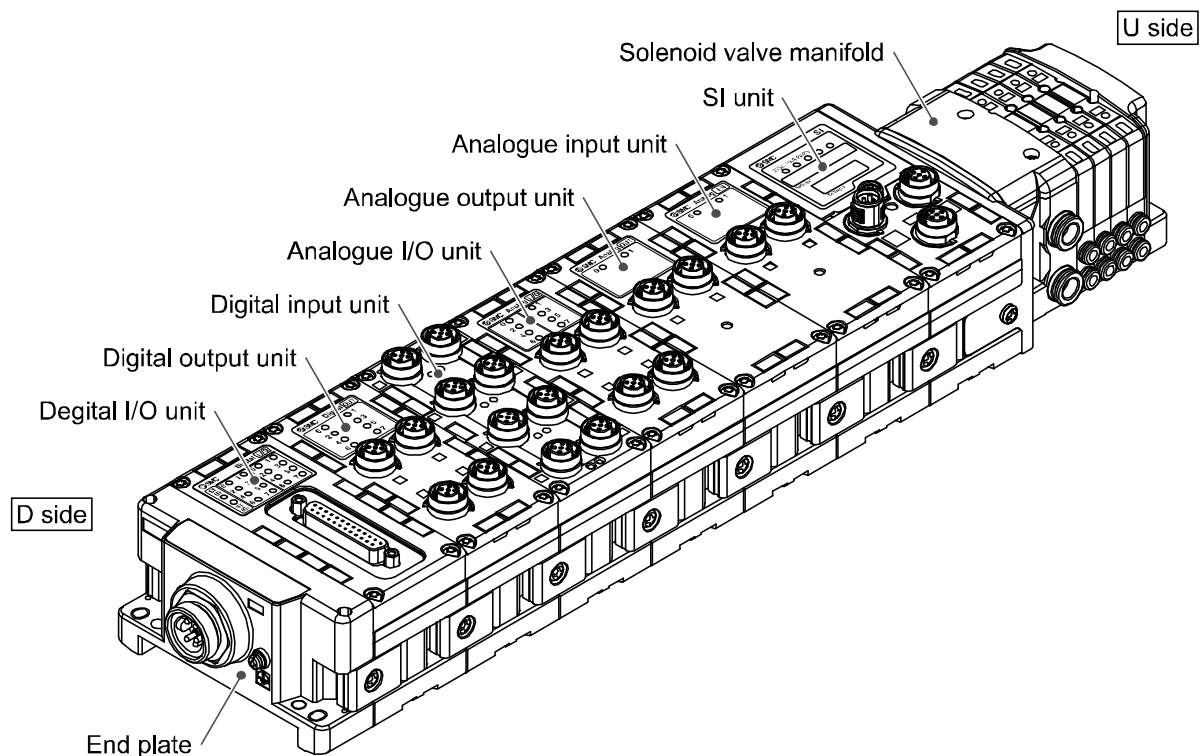

SI unit: Performs Fieldbus communication and solenoid valve manifold ON/OFF output.

Digital input unit: For connecting sensors with switch output capability. PNP and NPN types are available.

Digital output unit: For connecting output device such as solenoid valves, lamps, buzzers, etc. PNP and NPN types are available.

Digital I/O unit: This unit has both digital input and output functions. PNP and NPN types are available.

Analogue input unit: For connecting sensors with analogue output capability.

Analogue output unit: This can be connected to the equipment which can read analogue input.

Analogue I/O unit: This unit has both analogue input and output functions.

End plate: Connected at EX600 Manifold's D side, incorporating the power supply connection.

Solenoid valve manifold: An assembly of solenoid valves. One connector is used as the electric connection to all connected valves.

## ■ Definition and terminology

|   | Terminology              | Definition   |
|---|--------------------------|--|
| A | AD value                 | The signal from the analogue input device is converted to digital, and displayed in decimal and hexadecimal. These hexadecimal and decimal values are also outputted to the analogue output device.  |
| C | Communication speed      | The speed at which the fieldbus sends and receives data. It depends on higher-level equipment (PLC, etc.) and is measured in bps (Bits per second).  |
|   | Current consumption      | The current necessary to operate each unit.  |
| D | DIN rail                 | A metal rail conforming with DIN (German) standard.  |
|   | D Side                   | The side connected to the end plate when the product is connected to a manifold.   |
| E | Enclosure (IP□□)         | Abbreviation of international (ingress) protection. A standard related to the protection from external objects (hands, steel ball, steel wire, dust, water, etc.) applied to the product.  |
| F | FE                       | Abbreviation of functional earth.  |
|   | Fieldbus                 | The protocol that uses digital communication to exchange signals between field equipment (instruments and actuators) running on site and a PLC.  |
| H | Handheld Terminal (H.T.) | Connected to the dedicated connector of the SI unit to adjust the internal parameters, monitor the status of all input and output signals, and turn on input and output forcedly.  |
| M | Manifold                 | A form consisting of multiple components. A form made by combining multiple components   |
| N | Station number           | 0 is assigned to the master station of CC-Link. 1 to 64 are assigned to slave stations. It is necessary to assign station numbers to slave stations taking into consideration the number of occupied stations, so that the station numbers are not duplicated. |
|   | NPN input                | Takes the sensor output that uses the NPN transistor to the signal output line.  |
|   | NPN output               | The output type that uses an NPN transistor to operate output device. It is also known as a positive common type since a positive potential is applied to the power supply line.   |
|   | Number of inputs         | The number of points that can receive information from input device (sensor, switch, etc.).  |
|   | Number of outputs        | The number of points that can operate output device (solenoid valve, light, motor, etc.).  |
|   | Number of stations       | The total number of occupied slave stations connected to CC-Link.  |
| O | Occupied station number  | Station number that one slave station uses on the network. It can be set from 1 to 4 stations depending on the number of data. Remote I/O occupies only one station.   |
|   | Open circuit detection   | A diagnosis function to detect if the input or output device wiring is disconnected.   |
| P | PLC                      | Abbreviation of programmable logic controller. A digital computer used for automation of electromechanical processes.  |
|   | PNP input                | Takes the sensor output that uses the PNP transistor to the signal output part.  |
|   | PNP output               | The output type that uses a PNP transistor to operate output device. It is also known as a negative common type since a negative potential is applied to the power supply line.  |
| R | Remote device station    | Collective description of slave station. Bit data and word data can be used in this station.   |
|   | Remote I/O               | Collective description of slave station. Only bit data can be used in this station. (Only one station is occupied.)  |

|   | Terminology              | Definition   |
|---|--------------------------|--|
| S | Short circuit detection  | A diagnosis function to detect an over current due to the short circuit of the output and/or power supply positive line with respect to the GND line.                                  |
|   | Short circuit protection | A function to protect the internal circuit from being broken by an over current due to the short circuit of the output and/or power supply positive line with respect to the GND line. |
|   | SI unit                  | Abbreviation of serial interface unit. A unit connected to a PLC to communicate input and output data.   |
| T | Terminal resistor        | A resistor mounted at either end of the fieldbus network.  |
| U | U Side                   | The side connected to the solenoid valve when the product is connected to a manifold.  |
| V | Ver.2.00                 | Ver. 2.00 means "CC-Link Ver. 2.00". It allows sending/ receiving large amounts of data such as the sending/ receiving of multiple channel analogue/ digital converted data.           |

# Assembly

## Basic precautions

The units that can be connected vary depending on the Handheld Terminal product number.

| Units that can be assembled |                     | Product number of the Handheld Terminal |            |   |
|-----------------------------|---------------------|---|------------|---|
|                             |                     | EX600-HT1                               | EX600-HT1A |   |
| Product number              | SI unit             | EX600-SMJ□                              | ○          | ○ |
|                             | Digital input unit  | EX600-DX□B                              | ○          | ○ |
|                             |                     | EX600-DX□C□                             | ○          | ○ |
|                             |                     | EX600-DX□D                              | ○          | ○ |
|                             |                     | EX600-DX□E                              | ×          | ○ |
|                             |                     | EX600-DX□F                              | ×          | ○ |
|                             | Disital output unit | EX600-DY□B                              | ○          | ○ |
|                             |                     | EX600-DY□E                              | ×          | ○ |
|                             |                     | EX600-DY□F                              | ×          | ○ |
|                             | Digital I/O unit    | EX600-DM□E                              | ×          | ○ |
|                             |                     | EX600-DM□F                              | ×          | ○ |
|                             | Analogue input unit | EX600-AXA                               | ○          | ○ |
| Analogue output unit        | EX600-AYA           | ×                                       | ○          |   |
| Analogue I/O unit           | EX600-AMB           | ×                                       | ○          |   |

\*1: EX600-HT1 cannot recognize EX600-D□□E, EX600-D□□F, Ex600-AYA and EX600-AMB.

Find the product number of the Handheld Terminal referring to the label shown in the figure below.

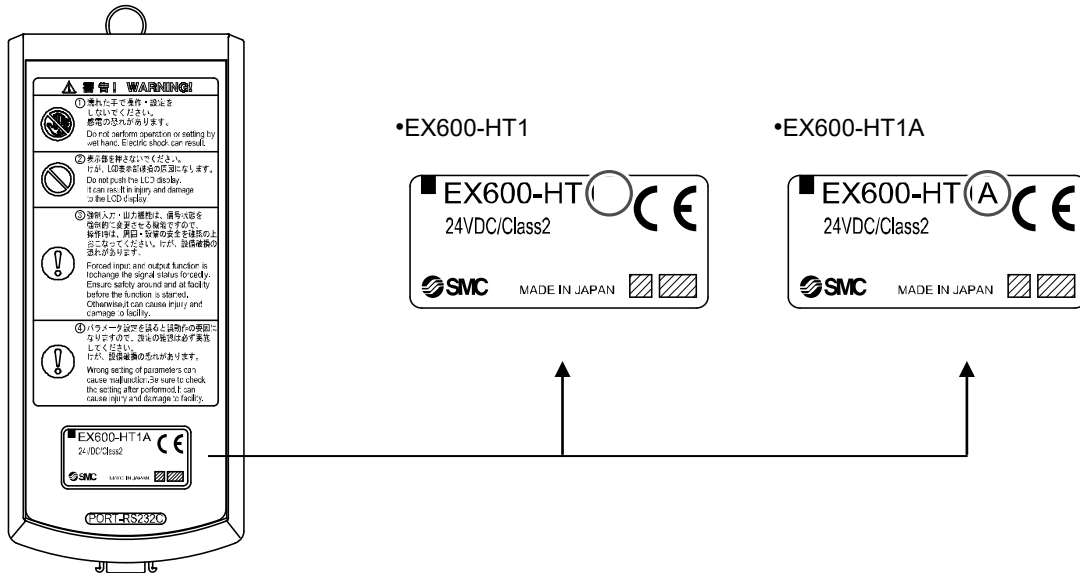

•Composing the unit as a manifold

\*: If the unit was purchased as a manifold, the work described in this section is not necessary.

(1)Connect the unit to the end plate.

The Digital unit, Analogue unit can be connected in any order.

Tighten the bracket of the joint using tightening torque 1.5 to 1.6 Nm.

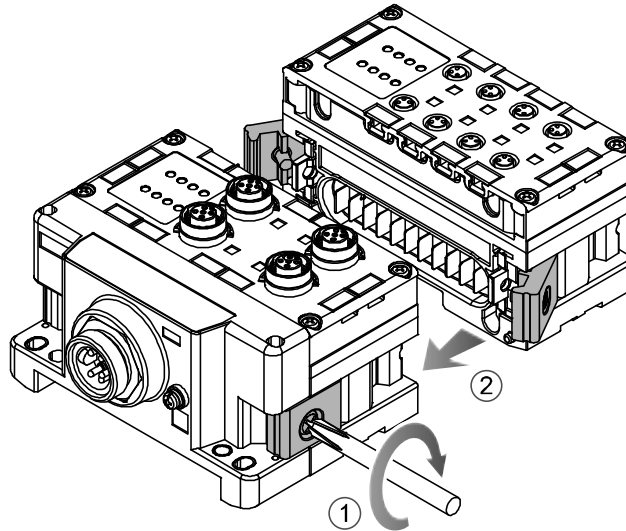

(2)Add more units.

Up to 10 units (including the SI unit) can be connected to one manifold.

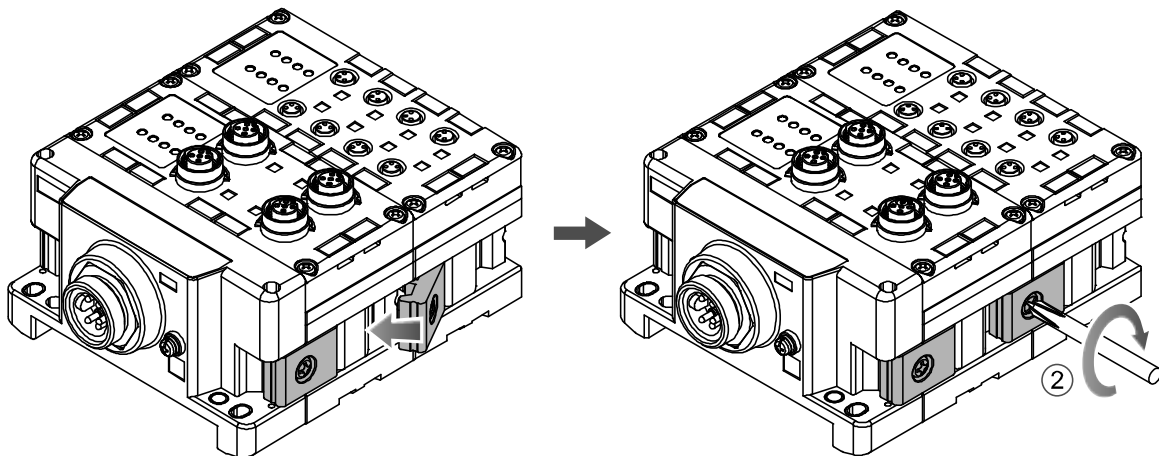

(3)Connecting the SI unit.

After connecting the necessary units, connect the SI unit.

Connecting method is the same as above (1), (2).

(4) Mounting the valve plate.

Mount the valve plate (EX600-ZMV□) to the valve manifold using the valve set screws. (M3 x 8)  
Apply 0.6 to 0.7 Nm tightening torque to the screws.

| Screw mounting place |            |
|----------------------|------------|
| SV                   | : 2 places |
| S0700                | : 2 places |
| VQC1000              | : 2 places |
| VQC2000              | : 3 places |
| VQC4000              | : 4 places |
| SY                   | : 2 places |

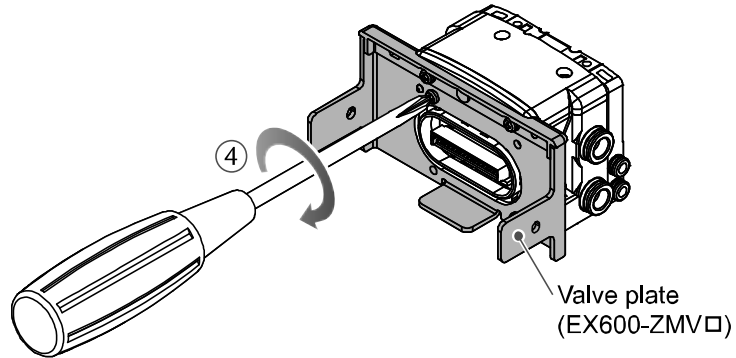

(5) Connect the SI unit and the valve manifold.

Insert the valve plate to the valve plate set groove on the side of SI unit.  
Then, tighten it with the valve plate set screws (M4 x 6) to fix the plate.  
Tightening torque for set screws 0.7 to 0.8 Nm.

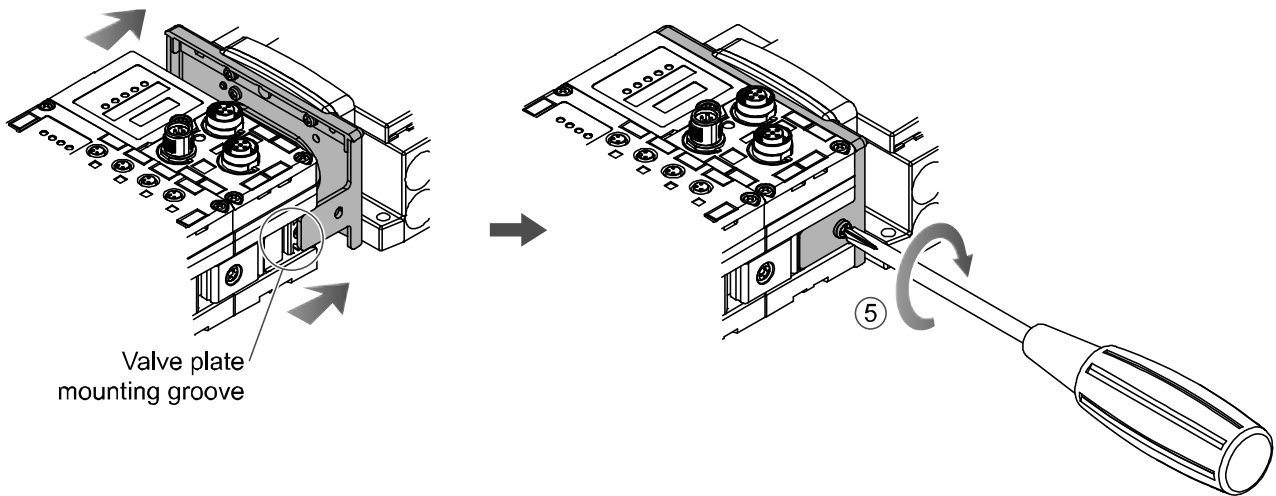

● Precautions for handling

- Please do not connect the unit while the power supply is active. It will cause equipment damage.
- Take care not to drop the nuts of Joint bracket.

# Mounting and Installation

## ■ Installation

### • Direct mounting

(1) When joining six or more units, fix the middle part of the complete EX600 unit with an intermediate reinforcing brace (EX600-ZMB1) before mounting using 2-M4 x 5 screws.

Tightening torque: 0.7 to 0.8 Nm.

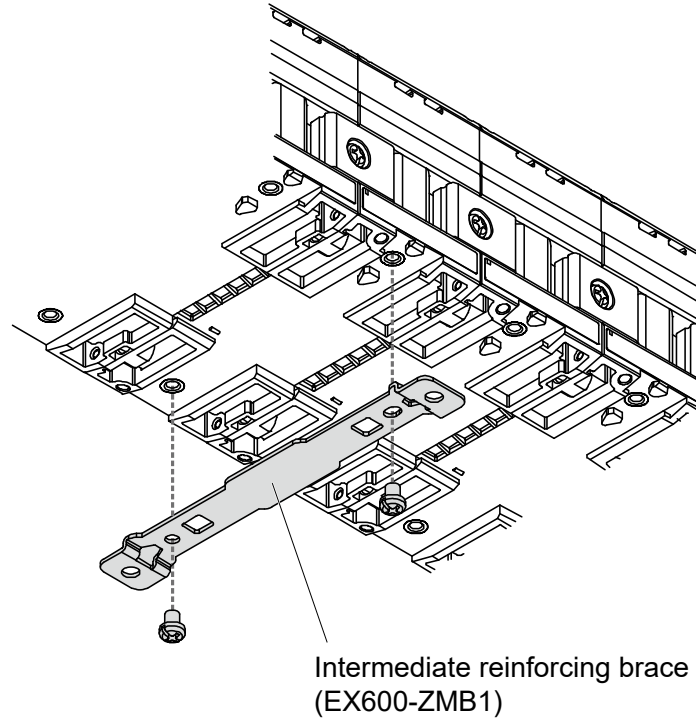

(2) Fix and tighten the end plates at one end of the unit. (M4)

Tightening torque: 0.7 to 0.8 Nm.

Fix the end plate at the valve side while referring to the operation manual of the corresponding valve manifold.

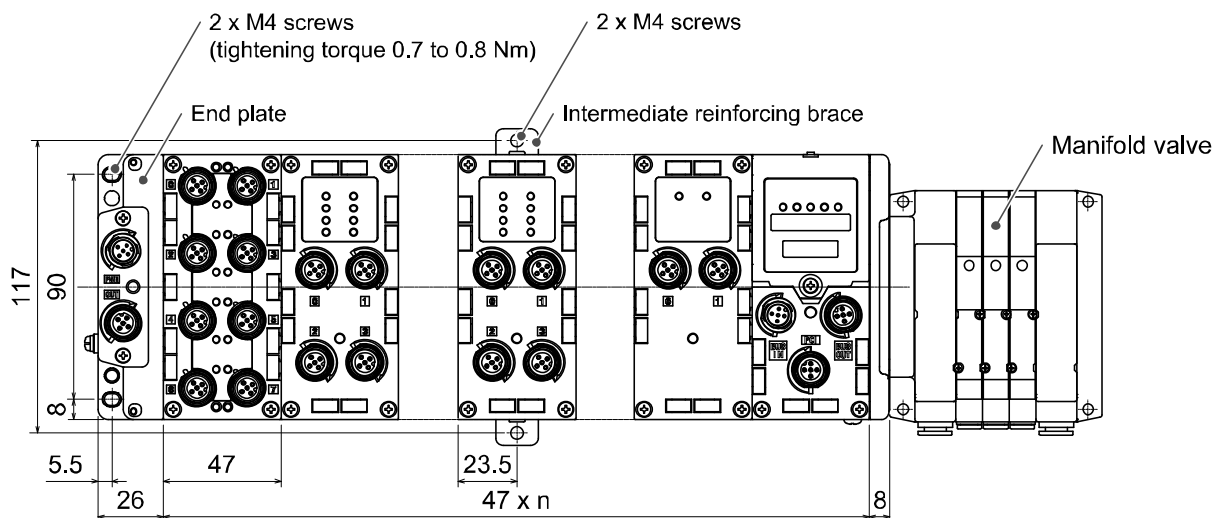

n (Number of connected units)  $\leq 10$

•DIN rail mounting

(Available for series other than SY series. Refer to the catalog for SY series.)

(1)When joining six or more units, fix the middle part of the complete EX600 unit with an intermediate reinforcing brace (EX600-ZMB2) before mounting, using 2-M4 x 6 screws.

Tightening torque: 0.7 to 0.8 Nm.

(2)Mount the end plate bracket (EX600-ZMA2) to the end plate at the opposite end to the valves, using 2-M4 x 14 screws.

Tightening torque: 0.7 to 0.8 Nm.

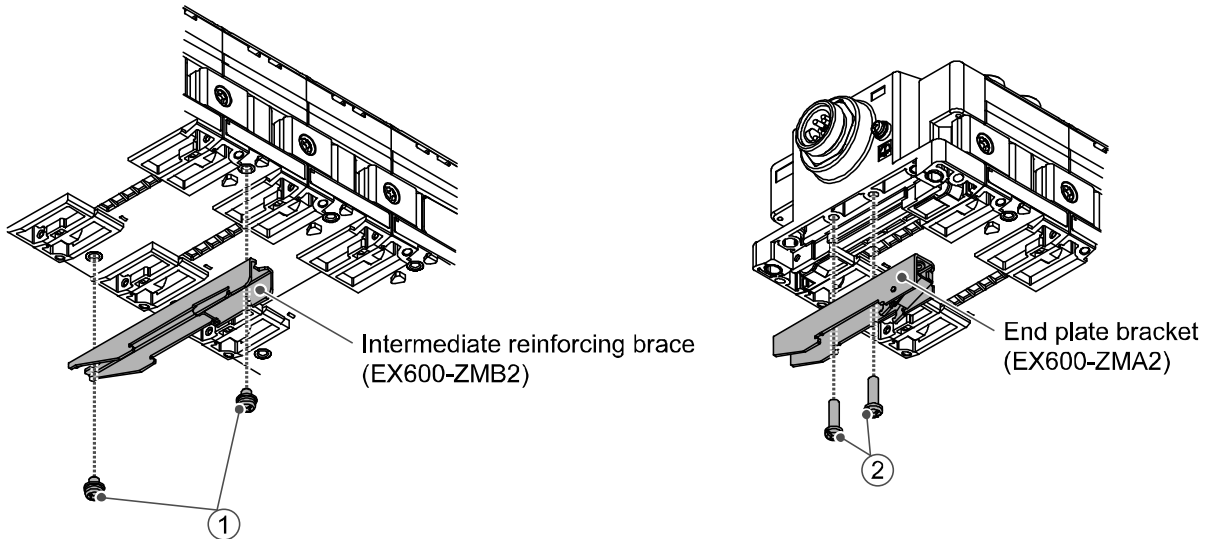

(3)Hook the DIN rail mounting groove to the DIN rail.

(4)Press the manifold using its side hooked to the DIN rail as a fulcrum until the manifold is locked.

(5)Fix the manifold by tightening the DIN rail fixing screws of the EX600-ZMA2. (M4 x 20)

Tightening torque: 0.7 to 0.8 Nm.

The tightening torque at the valve side depends on the valve type.

Refer to the operation manual of the corresponding valve manifold.

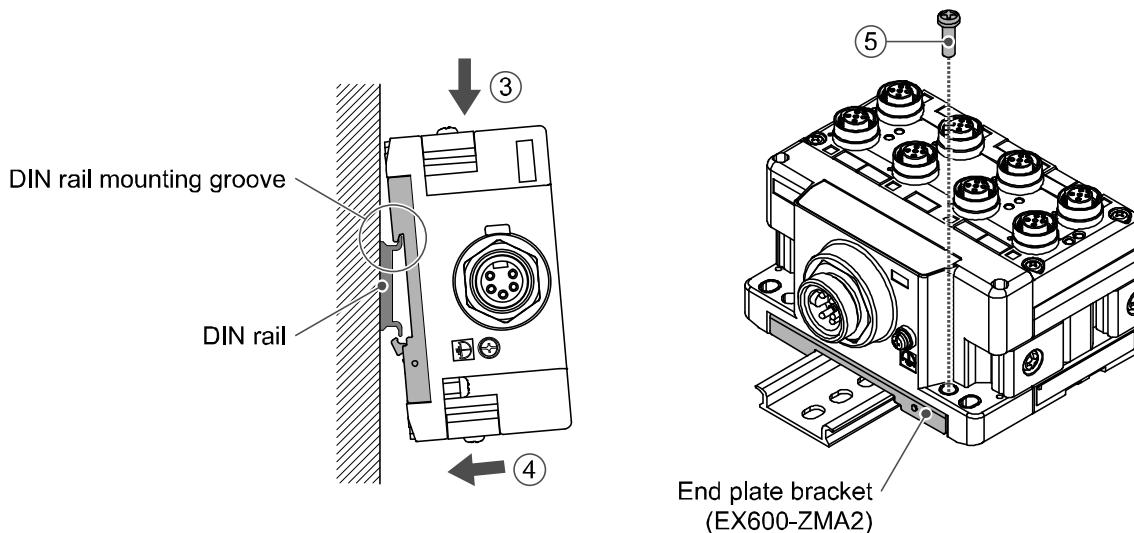



## ■Wiring

•Connect the M12 or M8 connector cable. M12 connector is applicable for SPEEDCON connector. SPEEDCON connector wiring method is explained below.

(1)Align the mark B on the metal bracket of the cable side connector (plug/socket) with the mark A.

(2)Align the mark C on the unit and insert the connector into the unit vertically.

If they are not aligned, the connector cannot be joined properly.

(3)When the mark B of the connector has been turned 180 degrees (1/2 turn), wiring is completed. Confirm that the connection is not loose. If turned too far, it will become hard to remove the connector.

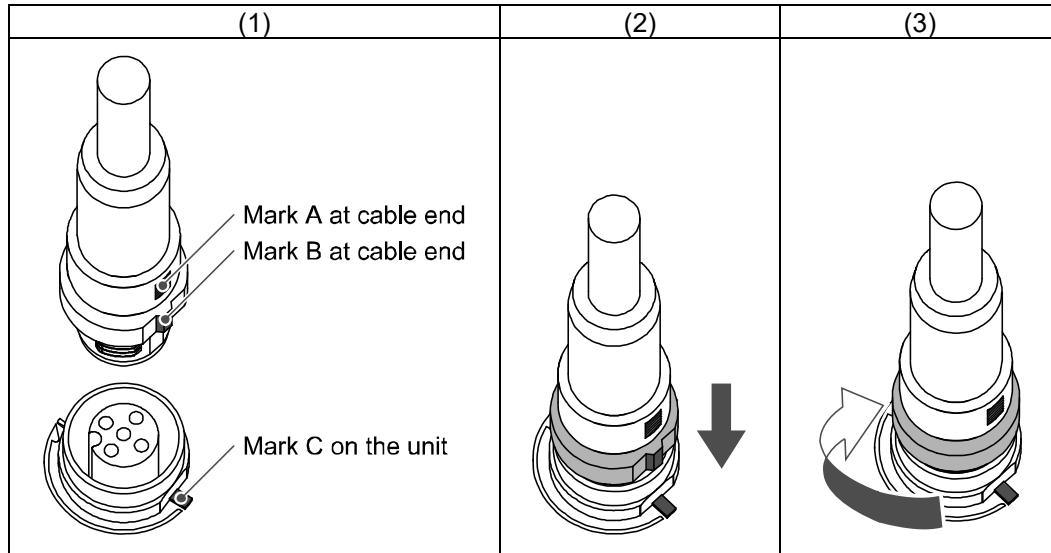

## •Mounting the marker

Signal name of the input or output devices and unit address can be written to the marker, and it can be installed to each unit.

Mount the marker (EX600-ZT1) into the marker groove as required.

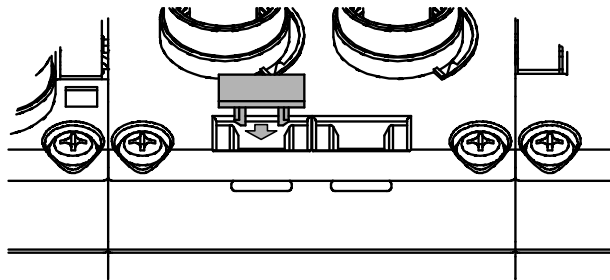

## SI unit

### Model Indication and How to Order

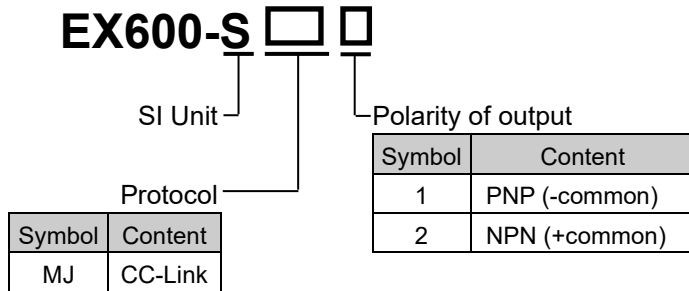

### Summary of Product parts

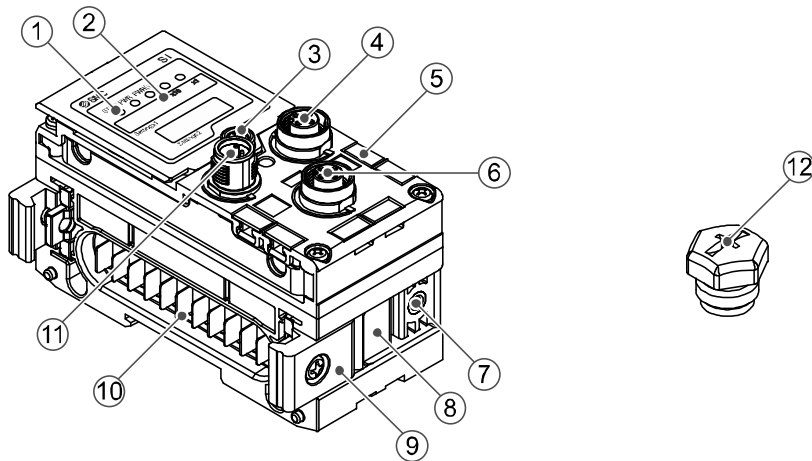

| No. | Description                     | Function  |
|-----|---------------------------------|---|
| 1   | Status display LED              | Displays the status of the unit.                        |
| 2   | Display cover                   | Open for the setting of switch.                         |
| 3   | Display cover tightening screw  | Loosen to open the display cover.                       |
| 4   | Connector (BUS OUT)             | Connects the cable for fieldbus outputs.                |
| 5   | Marker groove                   | Groove to mount a marker.                               |
| 6   | Connector (PCI)                 | Connects the cable of the Handheld Terminal.            |
| 7   | Valve plate mounting screw hole | Fixes the valve plate.                                  |
| 8   | Valve plate mounting groove     | Groove to insert the valve plate into.                  |
| 9   | Joint bracket                   | Bracket for joining to adjacent units.                  |
| 10  | Unit connector (Plug)           | Transmits signals and power supplies to adjacent units. |
| 11  | Connector (BUS IN)              | Connects the cable for fieldbus inputs.                 |
| 12  | Seal cap (2 pcs.)               | Mounted on to unused connectors. (BUS OUT and PCI)      |

# Mounting and Installation

## ■Wiring

### ○Connector pin assignment and circuit diagram

#### •Connector pin assignment

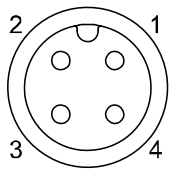
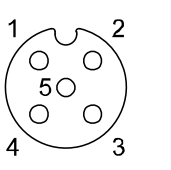
| Configuration   |   | Pin number | Signal name |
|---|---|------------|-------------|
| BUS IN  | BUS OUT   |            |             |
|  |  | 1          | SLD         |
|   |   | 2          | DB          |
|   |   | 3          | DG          |
|   |   | 4          | DA          |
|   |   | 5          | NC          |

#### •Circuit diagram

The product has T branching internally in the unit as shown in the circuit diagram below. It can be extended by connecting the CC-Link slave with BUS OUT.

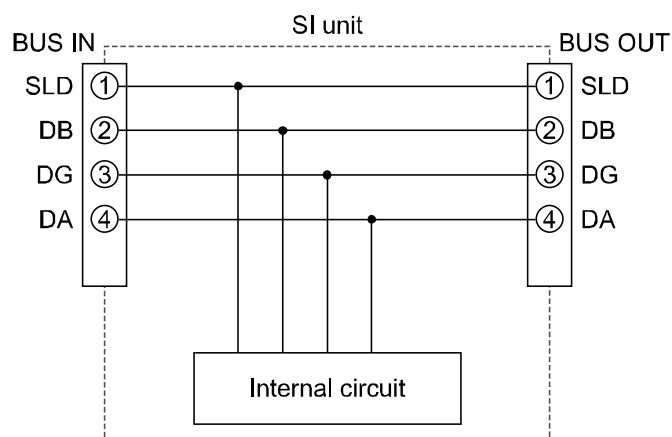

#### •Precautions for handling

- Be sure to connect terminal resistors to both ends of the CC-Link main line.
- Be sure to fit a seal cap on any unused connectors. Proper use of the seal cap enables the enclosure to achieve IP67 specification.

#### •Terminal resistors

The terminal resistors to be connected to the CC-Link system depend on the cables used.

| Type of cable   | Resistance  | Terminal resistor model No. (Manufacturer)  |
|---|-------------|---|
| Communication cable for CC-Link<br>PCA-1567720 (Socket)<br>PCA-1567717 (Plug) | 110 Ω 1/2 W | <ul style="list-style-type: none"> <li>•VA-4DCC-110 (Correns)</li> <li>•CC100 (Woodhead Japan)</li> </ul> |
| CC-Link dedicated high-performance cable                                      | 130 Ω 1/2 W | <ul style="list-style-type: none"> <li>•VA-4DCC-130 (Correns)</li> </ul>                                  |

## Setting and Adjustment

### •Switch setting

- (1) Loosen the display cover screw.
- (2) Open the display cover using a flat head screwdriver, etc.

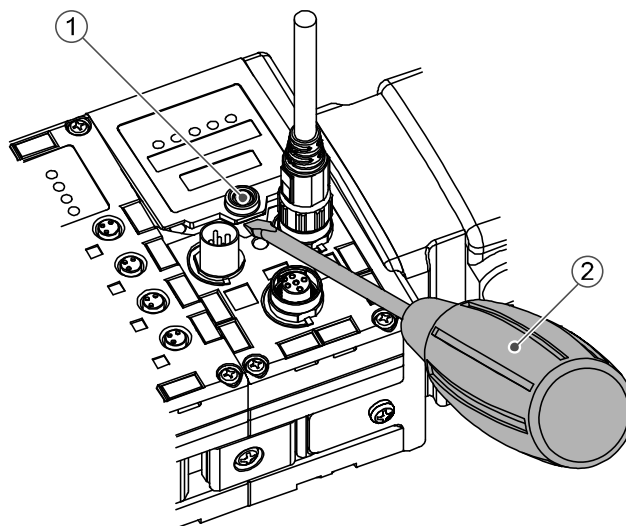

- (3) Set the switch using a small watchmaker's screwdriver with a thin blade, referring to the setting of switch on the following pages.
- (4) After setting the switch, tighten the display cover tightening screw in the reverse order of the above procedure. (Tightening torque: 0.3 to 0.4 Nm)

### •Precautions for handling

- Turn off the power supply whilst setting the switch.
- If there is foreign matter or water droplets around the display cover, clean it off before opening the cover.
- When setting the switch, do not touch other unrelated parts. This can cause parts damage or malfunction due to a short circuit.
- All default settings are OFF or 0. Perform the setting of the switch before using this product.
- When introducing power supply, switch setting will become effective.

- Operation mode switch: Sets the version of CC-Link and the number of occupied stations.

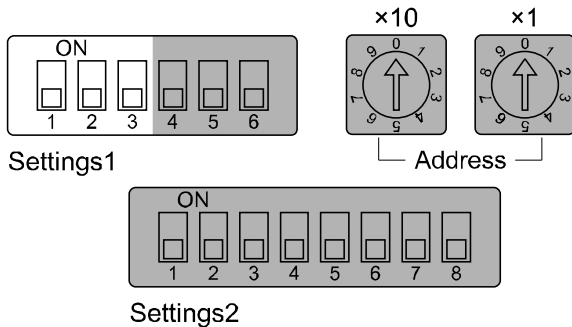

| Operating mode | Settings1 |     |     | Content         |                             |                         |                                       |                           |
|----------------|-----------|-----|-----|-----------------|-----------------------------|-------------------------|---------------------------------------|---------------------------|
|                | 1         | 2   | 3   | CC-Link version | Number of occupied stations | Bit area input/output*2 | Word area input/output size (RWr/RWr) | Extended cyclic (Ver2.00) |
| 1 *1           | OFF       | OFF | OFF | 1.10            | 1                           | 32/32                   | 4 word/4 word                         | -                         |
| 2              | ON        | OFF | OFF | 1.10            | 2                           | 64/64                   | 8 word/8 word                         | -                         |
| 3              | OFF       | ON  | OFF | 1.10            | 3                           | 96/96                   | 12 word/12 word                       | -                         |
| 4              | ON        | ON  | OFF | 1.10            | 4                           | 128/128                 | 16 word/16 word                       | -                         |
| 5              | OFF       | OFF | ON  | 2.00            | 1                           | 64/64                   | 16 word/16 word                       | 4 times                   |
| 6              | ON        | OFF | ON  | 2.00            | 1                           | 128/128                 | 32 word/32 word                       | 8 times                   |
| 7              | OFF       | ON  | ON  | 2.00            | 2                           | 384/384                 | 64 word/64 word                       | 8 times                   |
| 8              | ON        | ON  | ON  | 2.00            | 3                           | 640/640                 | 96 word/96 word                       | 8 times                   |

\*1: The default operation mode at the time of shipment is mode 1.

\*2: The last register of bit area (16 bits) cannot be used as they are allocated for the system area.

- Communication speed switch: Sets the communication speed of CC-Link.

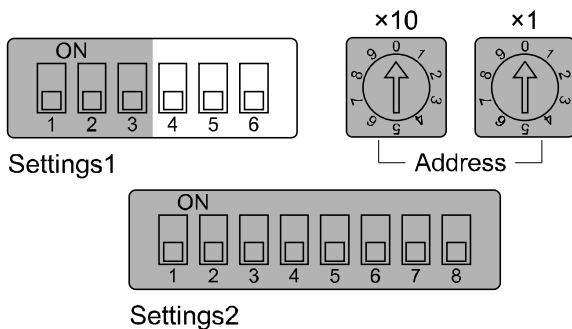

| Settings1 |     |     | Content                      |
|-----------|-----|-----|------------------------------|
| 4         | 5   | 6   |                              |
| OFF       | OFF | OFF | 156 kbps (Default setting)   |
| ON        | OFF | OFF | 625 kbps                     |
| OFF       | ON  | OFF | 2.5 Mbps                     |
| ON        | ON  | OFF | 5 Mbps                       |
| OFF       | OFF | ON  | 10 Mbps                      |
| ON        | OFF | ON  | Error, [LERR] LED lights up. |
| OFF       | ON  | ON  |                              |
| ON        | ON  | ON  |                              |

•Station setting switch: Set the station number of SI unit

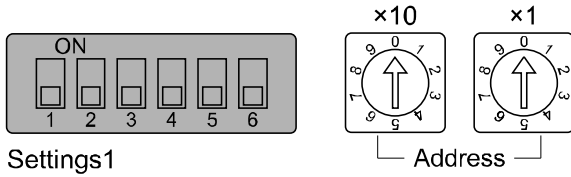

Settings1

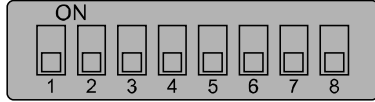

Settings2

Station number setting

| Address |    | Station number          |
|---------|----|-------------------------|
| x10     | x1 |                         |
| 0       | 0  | Error (Default setting) |
| 0       | 1  | 1                       |
| 0       | 2  | 2                       |
| :       | :  | :                       |
| 6       | 3  | 63                      |
| 6       | 4  | 64                      |
| 6       | 5  | Error                   |
| :       | :  |                         |
| 9       | 9  |                         |

\*: If a station number is set to 00 or over 65, the "LERR" LED will light up.

The settable range depends on the number of occupied stations.

| Number of occupied stations | Settable station number range |
|-----------------------------|-------------------------------|
| 1                           | 1 to 64                       |
| 2                           | 1 to 63                       |
| 3                           | 1 to 62                       |
| 4                           | 1 to 61                       |

\*: The number of occupied stations is set by the operation mode switch. (Refer to the previous page.)

- V\_SEL switch: Select the number of occupied valve outputs.  
Select the number of outputs (size) that SI unit occupies.

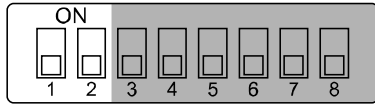
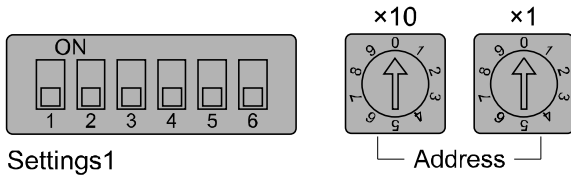

Settings2

| Settings2 |     | Content                             | SI unit output data size |
|-----------|-----|-------------------------------------|--------------------------|
| 1         | 2   |                                     |                          |
| OFF       | OFF | Number of occupied valve 32 outputs | 4 byte (Default setting) |
| OFF       | ON  | Number of occupied valve 24 outputs | 3 byte                   |
| ON        | OFF | Number of occupied valve 16 outputs | 2 byte                   |
| ON        | ON  | Number of occupied valve 8 outputs  | 1 byte                   |

\*: Set the number of occupied outputs more than the number of valves used.

- Baud Rate switch: Set the communication speed of the EX600 internal bus.

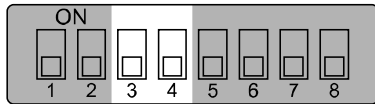
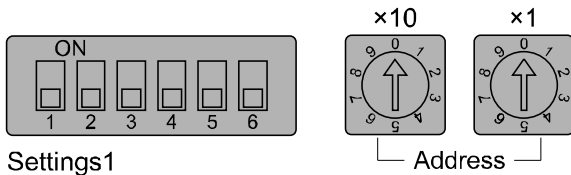

Settings2

| Settings2 |     | Content                  |
|-----------|-----|--------------------------|
| 3         | 4   |                          |
| OFF       | OFF | 1 Mbps (Default setting) |
| OFF       | ON  | 500 kbps                 |
| ON        | OFF | 250 kbps                 |
| ON        | ON  | 125 kbps                 |

\*: This function is for extension in the future. Use the product with 1 Mbps (Default setting).

•Switch for diagnosis: Allocates the diagnostic data to the input word area.

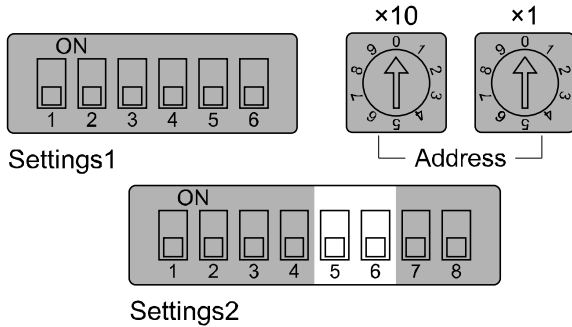

| Settings2 |     | Mode | Content   | Diagnosis size set for the input |
|-----------|-----|------|---|----------------------------------|
| 5         | 6   |      |   |                                  |
| OFF       | OFF | 0    | Input data only (Default setting)                               | 0 word                           |
| OFF       | ON  | 1    | Input data + System diagnosis                                   | 2 word                           |
| ON        | OFF | 2    | Input data + System diagnosis + Unit diagnosis (Up to 10 units) | 3 word                           |
| ON        | ON  | 3 *  | Input data + System diagnosis + Unit diagnosis (Up to 64 units) | 6 word                           |

\*: Mode 3 is a function for extension in the future. Do not use it now.

•HOLD/CLEAR switch: Sets the output status when the Fieldbus has a communication error.

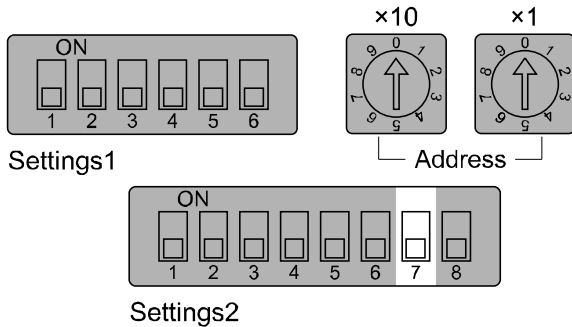

| Settings2 | Content                          |
|-----------|----------------------------------|
| 7         |                                  |
| OFF       | Output is OFF. (Default setting) |
| ON        | Holds the output.                |

\*: Refer to "Parameter setting" (page 44), for the further details.



- Configuration memory switch: When the manifold configuration memory switch is set ON and the power supply is switched ON, the system will compare the stored configuration with the manifold configuration. If the configuration is different, diagnostic error will be generated.

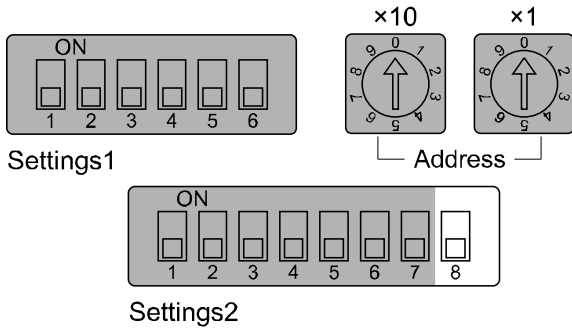

| Settings2 | Content                                 |
|-----------|---|
| 8         |   |
| OFF       | Normal operation mode (Default setting) |
| ON        | Configuration memory mode               |

Timing to memorize the configuration → When power supply for control and input is turned on, with the switch above turned OFF.

Timing to compare the configuration → When power supply for control and input is turned on, with the switch above turned ON.

- Precautions for handling

Handle the switch with care. Excessive force can break the switch.

## LED Display

The status display LED displays the power supply and communication status.  
Various kinds of status can be checked as follows:

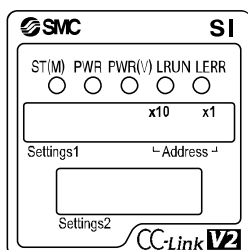





| Display | Content  |
|---------|--|
| ST(M)   | Displays the diagnosis status of the unit.                             |
| PWR     | Displays the status of the power supply voltage for control and input. |
| PWR(V)  | Displays the status of the power supply voltage for outputs.           |
| LRUN    | Displays the data link status.   |
| LERR    | Displays the error status.   |

### •SI unit common status

| LED display                                       | Content  |
|---|--|
| ST(M) PWR PWR(V)<br>○ ○ ○<br>OFF                  | The power supply for control and input is OFF.   |
| ST(M) PWR PWR(V)<br>● ● ●<br>Green LEDs are ON    | The unit is in normal operation.   |
| ST(M) PWR PWR(V)<br>● ○ ○<br>Red ST(M) LED is ON  | A component failure inside the SI unit.  |
| ST(M) PWR PWR(V)<br>○ ● ○<br>Red PWR LED is ON    | The power supply voltage for control and input is abnormal.  |
| ST(M) PWR PWR(V)<br>○ ○ ●<br>Red PWR(V) LED is ON | The power supply voltage for outputs is abnormal.  |
| ST(M) PWR PWR(V)<br>● (flashing) ○ ○              | A unit other than the SI unit has been diagnosed and detected.   |
| ST(M) PWR PWR(V)<br>● (flashing) ○ ○              | Either of the following conditions:<br>•The valve ON/OFF counter has exceeded the set value.<br>•The valve is short circuited or disconnected. |
| ST(M) PWR PWR(V)<br>● (flashing alternately) ○ ○  | Either of the following conditions:<br>•Connection error between units has occurred.<br>•Configuration memory error has occurred.              |

\*: Refer to "Troubleshooting" (page 34), for the further details of countermeasures.

•CC-Link status

| LED display  | Content  |
|--|--|
| LRUN LERR<br><br>OFF                      | Communication is not established. Or, the power supply for control and input is turned off.      |
| LRUN LERR<br><br>Green LRUN LED is ON     | Communication is normal.   |
| LRUN LERR<br><br>Red LERR LED is ON       | Communication error has occurred.  |
| LRUN LERR<br><br>Red LERR LED is flashing | The station setting or communication speed setting switch has been changed during communication. |

\*: Refer to "Troubleshooting" (page 34), for the further details of countermeasures.

# Specification

## ■ Specifications

| Model  |   | EX600-SMJ1   | EX600-SMJ2    |
|--|---|--|---------------|
| Communication  | Fieldbus                                    | CC-Link<br>(Ver.1.10, Ver.2.00)  |               |
|  | Station type                                | Remote device station  |               |
|  | Communication speed                         | 156/625 kbps<br>2.5/5/10 Mbps  |               |
|  | Occupied area<br>(Number of inputs/outputs) | Max. (512 points/512 points)<br>1 station/2 stations/3 stations/4 stations occupied          |               |
| Power supply (Control and input)   |   | 24 VDC Class2, 2 A   |               |
| Internal current consumption<br>(The power supply for control and input) |   | 75 mA or less  |               |
| Valve output   | Polarity of output                          | PNP (-common)  | NPN (+common) |
|  | Output channel                              | 32 outputs (8/16/24/32 outputs selectable)   |               |
|  | Connected load                              | Solenoid valve with lamp and circuit of protection of surge voltage<br>of 24 VDC 1.5 W (SMC) |               |
|  | Power supply (Output)                       | 24 VDC Class2, 2 A   |               |
|  | Output for com. error                       | HOLD/CLEAR/Force ON  |               |
|  | Protective function                         | Short circuit protection   |               |
| Environment  | Enclosure                                   | IP67 (With manifold assembled) *1  |               |
|  | Operating temperature range                 | -10 to 50 °C (Max. surrounding air temperature rating: 50 °C) *2                             |               |
|  | Storage temperature range                   | -20 to 60 °C   |               |
|  | Operating humidity range                    | 35 to 85%RH (No condensation)  |               |
|  | Withstand voltage                           | 500 VAC for 1 minute between external terminals and FE                                       |               |
|  | Insulation resistance                       | 500 VDC, 10 MΩ or more between external terminals and FE                                     |               |
|  | Pollution degree                            | For use in Pollution Degree 3 Environment (UL508)  |               |
| Standard   |   | CE/UKCA marked, UL (CSA)   |               |
| Weight   |   | 300 g  |               |

\*1: All unused connectors must have a waterproof cap fitted.

\*2: The UL compliant temperature is 0 to 50 °C.

■Dimensions (in mm)

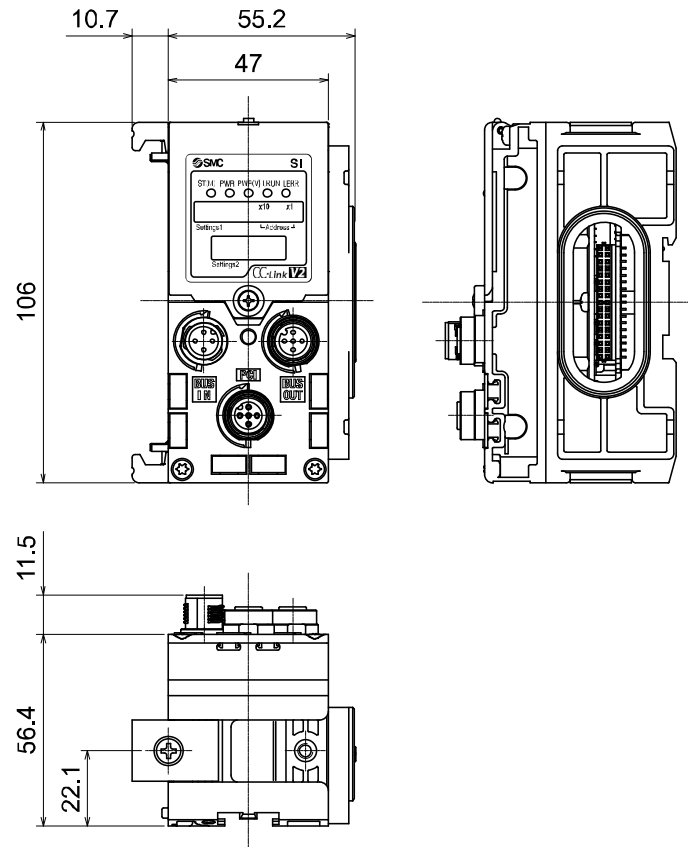

# End plate

## Model Indication and How to Order

**EX600-ED□-□**

End plate at D side

Mounting method

Connector

| Symbol | Content          |
|--------|------------------|
| 2      | M12 (5 pin)      |
| 3      | 7/8 inch (5 pin) |

| Symbol | Content   |
|--------|---|
| Nil    | No DIN rail bracket                             |
| 2      | With DIN rail bracket                           |
| 3      | With DIN rail bracket (Specified for SY series) |

## Summary of Product parts

•EX600-ED2-□

•EX600-ED3-□

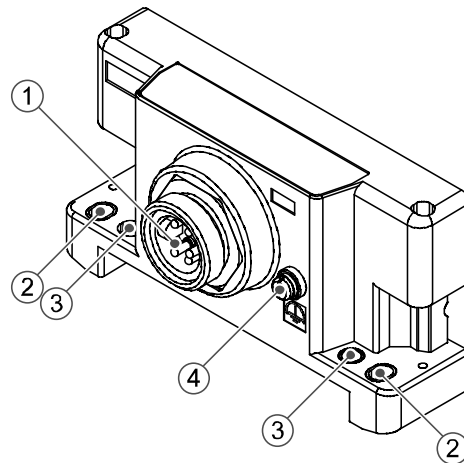
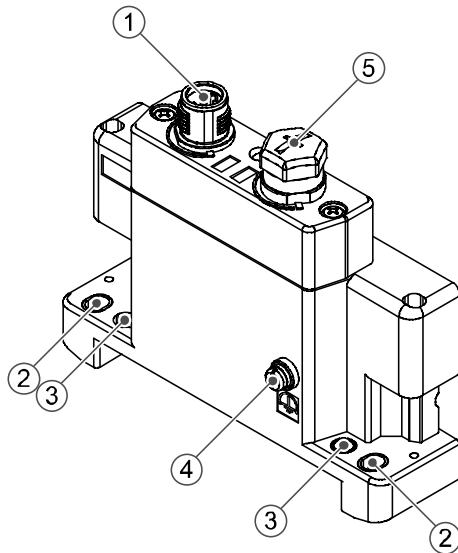

| No. | Description                     | Function   |
|-----|---------------------------------|--|
| 1   | Power connector                 | Connector for power supply to SI unit and I/O unit.                              |
| 2   | Fixing hole for direct mounting | Holes for direct mounting.   |
| 3   | DIN rail fixing hole            | Holes for fix DIN rail mounting.   |
| 4   | F.E. terminal *                 | Functional Earth terminal - must be connected directly to system earth (ground). |
| 5   | Connector (Not used)            | Unused connector. Do not remove seal cap.  |

\*: Individual grounding should be provided close to the product with a short cable.

# Mounting and Installation

## ■Wiring

### ○Connector pin assignment

#### (1)EX600-ED2-□

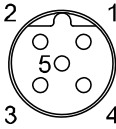
| Configuration   | Pin No. | Signal name              |
|---|---------|--------------------------|
|  | 1       | 24 V (Output)            |
|   | 2       | 0 V (Output)             |
|   | 3       | 24 V (Control and input) |
|   | 4       | 0 V (Control and input)  |
|   | 5       | F.E.                     |

#### (2)EX600-ED3-□

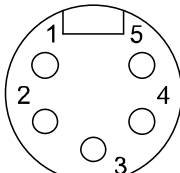
| Configuration   | Pin No. | Signal name              |
|---|---------|--------------------------|
|  | 1       | 0 V (Output)             |
|   | 2       | 0 V (Control and input)  |
|   | 3       | F.E.                     |
|   | 4       | 24 V (Control and input) |
|   | 5       | 24 V (Output)            |

### ○Regarding the 2 types of power supply

- Power supply for control and input: Supplying power for control of each unit's power supply for control and also for device connected to input port of Digital and Analogue unit.
- Power supply for output: Supplying power for equipment connected to output port of Digital and Analogue unit, and also power supply for solenoid valve manifold.

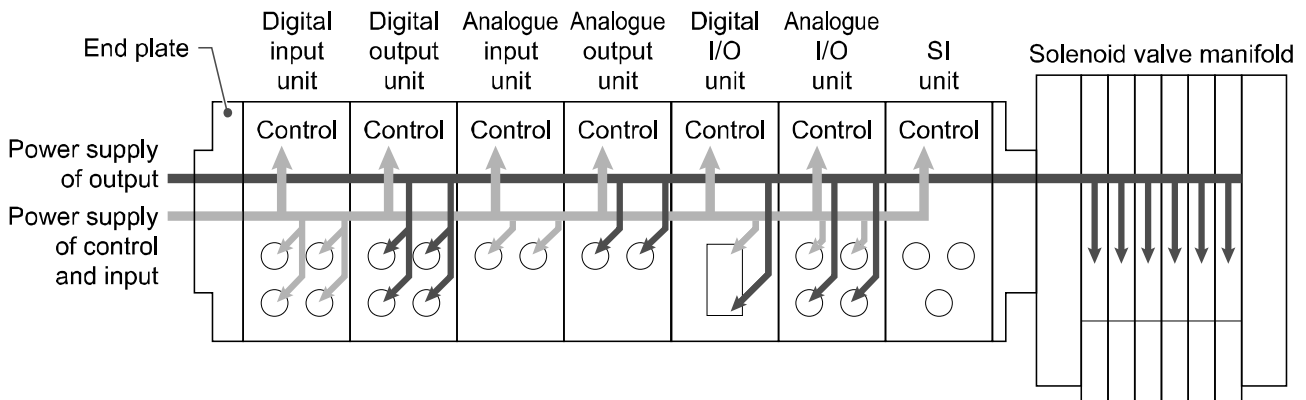

### ●Precautions for handling

Be sure to fit a seal cap on any unused connectors. Proper use of the seal cap enables the enclosure to achieve IP67 specification.

# Specification

## ■ Specifications

| Model            |   | EX600-ED2-□  | EX600-ED3-□           |
|------------------|---|--|-----------------------|
| Power            | Power connector                                   | M12 (5 pin) Plug   | 7/8 inch (5 pin) Plug |
|                  | Power supply (Control and input)                  | 24 VDC ±10% Class2, 2 A  | 24 VDC ±10%, 8 A      |
|                  | Power supply (Output)                             | 24 VDC +10/-5% Class2, 2 A                                       | 24 VDC +10/-5%, 8 A   |
| Environment      | Enclosure   | IP67 (With manifold assembled) *1                                |                       |
|                  | Operating temperature range                       | -10 to 50 °C (Max. surrounding air temperature rating: 50 °C) *2 |                       |
|                  | Storage temperature range                         | -20 to 60 °C   |                       |
|                  | Operating humidity range                          | 35 to 85%R.H. (No condensation)                                  |                       |
|                  | Withstand voltage                                 | 500 VAC for 1 minute between external terminals and F.E.         |                       |
|                  | Insulation resistance                             | 500 VDC, 10 MΩ min. between external terminals and F.E.          |                       |
| Pollution degree | For use in Pollution Degree 3 Environment (UL508) |  |                       |
| Standard         |   | CE/UKCA marked, UL (CSA)   |                       |
| Weight           |   | 170 g  | 175 g                 |

\*1: All unused connectors must have a seal cap fitted.

\*2: The UL agreement temperature is 0 to 50 °C.

## ■ Dimensions (in mm)

### •EX600-ED2-□

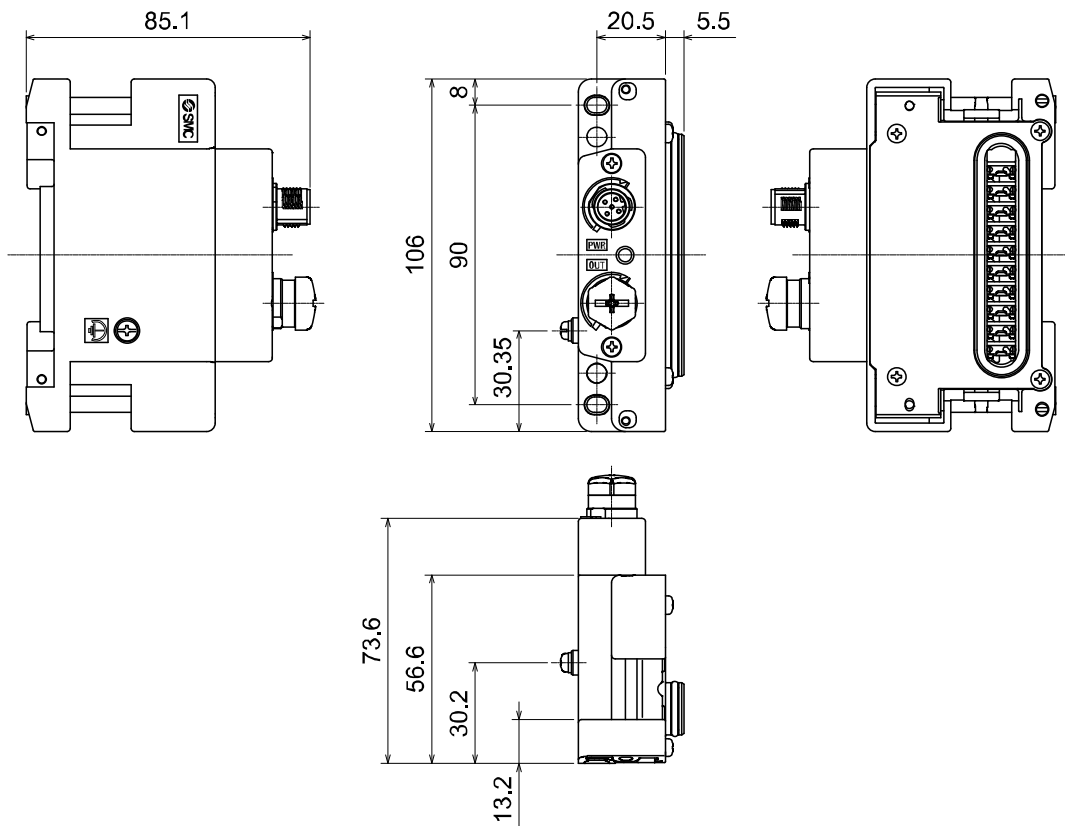



•EX600-ED3-□

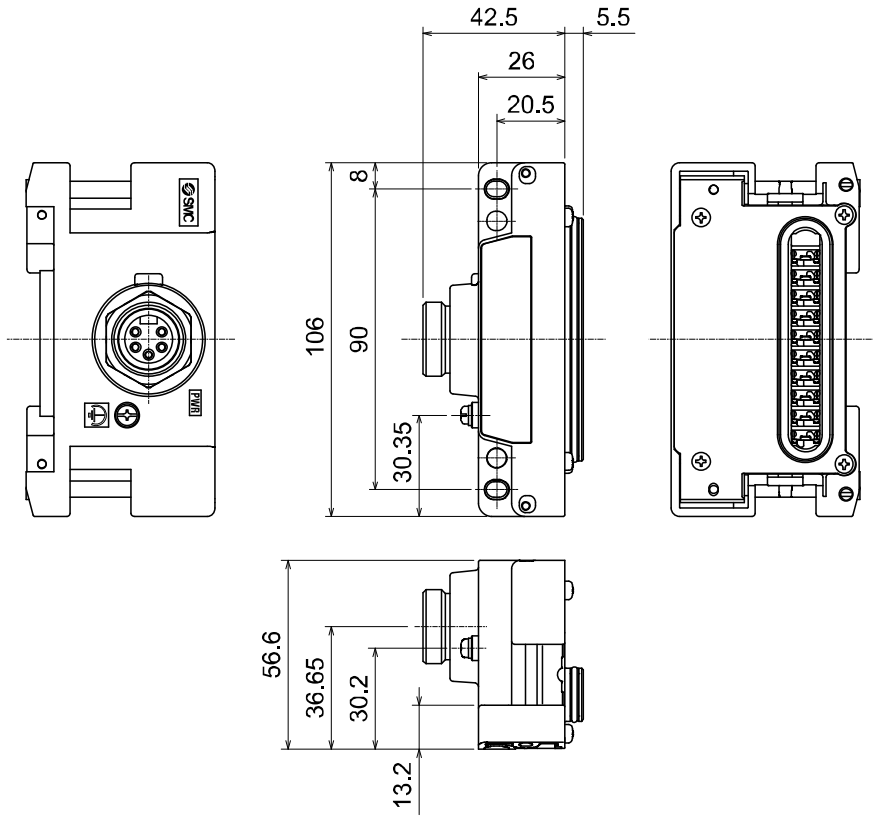

## Maintenance

Turn off the power supply, stop the supplied air, exhaust the residual pressure and verify the release of air before performing maintenance.

### Cleaning method

Use a soft cloth to remove stains.

For heavy stains, use a cloth soaked with diluted neutral detergent and fully squeezed, then wipe up the stains again with a dry cloth.

Do not use solvents such as benzene, thinner etc. to clean each unit.

| Inspection item                      | Content of inspection   |
|--------------------------------------|---|
| Connector/Electric wiring            | Connect properly if the connection is loose.  |
| Seal cap                             | Tighten properly if the connection is loose.  |
| Thread for mounting and installation | If the thread is loose, re-tighten it to the specified torque.  |
| Connection cables                    | If the cable is broken or any other abnormality is confirmed by appearance, replace the cable with a new one. |
| Supply source voltage                | Check if source voltage within the specification range (24 VDC $\pm$ 10%) is supplied.                        |

### How to reset the product for power cut or forcible de-energizing

Supply power to the product.

The output status just before the power failure is not maintained when power supply is recovered.

Start operation after confirming safety of the entire equipment.

# Troubleshooting

## •Troubleshooting

When any failure happens with this fieldbus system, the following chart is used to identify the cause of the failure.

Error status is reflected from the parameter setting of the fieldbus system.

When a failure occurs, take the appropriate countermeasures referring to the LED display, the troubleshooting and the parameter setting.

If a cause applicable to the failure cannot be identified, it indicates that the fieldbus system itself is broken. The fieldbus system breakage can be caused by the operating environment. Contact SMC separately to obtain countermeasures.

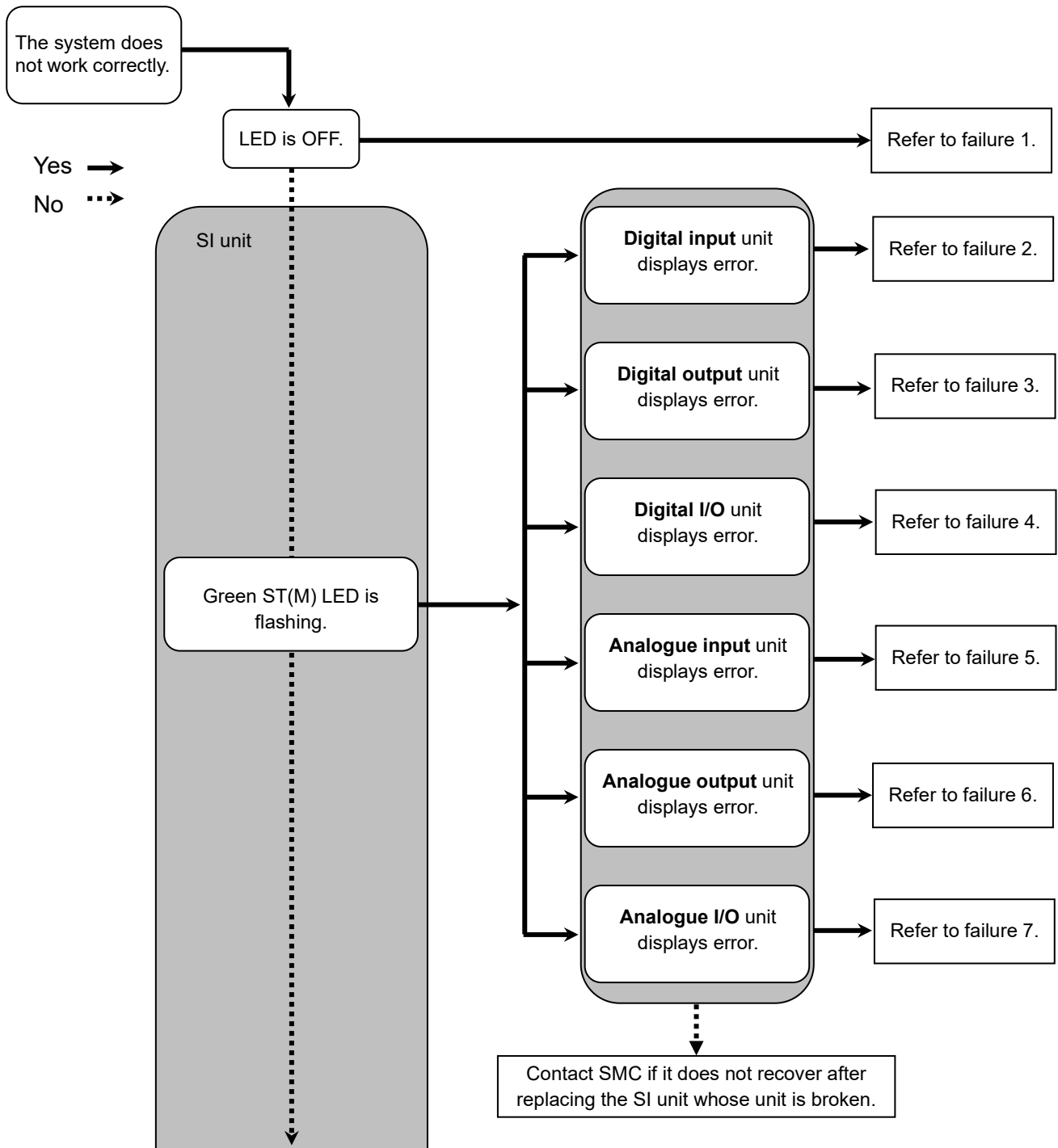

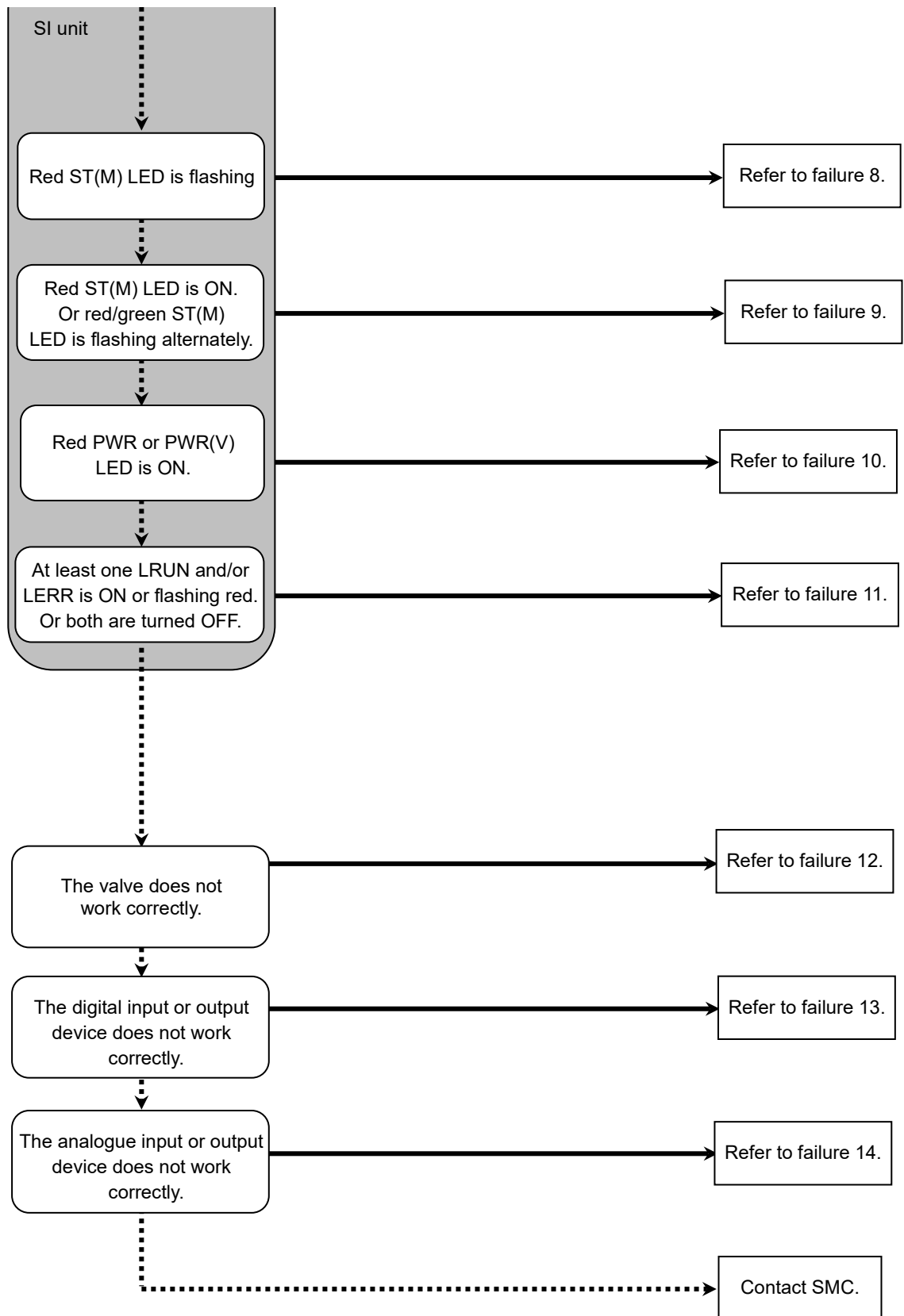

•Trouble counter measure method

| No. | Part No.<br>EX600-    | Problem   | Presumed cause   | Troubleshooting  |
|-----|-----------------------|---|--|--|
| 1   | -                     | LED is OFF.   | Power supply for control and input is OFF.   | Check if the power for control and input is supplied.  |
| 2   | DX□B<br>DX□C□<br>DX□D | Red LED is ON.<br>(Diagnosis is activated)          | Diagnosis error<br>Input device power supply is short-circuited.   | Check the parts with error by using the LED display or PLC * or H.T. Re-wire the short-circuited part or check if the cable and input device are normal.   |
|     |                       | Red LED is flashing.<br>(Diagnosis is activated)    | Diagnosis error<br>(1)ON/OFF count of the input device has exceeded the set value.<br>(2)The wire of the input device is broken or disconnected.<br>(Only EX600-DX□C1) | Check the parts with error by using the LED display or PLC * or H.T.<br>(1)Reset the ON/OFF count to zero or change the set value. Or invalidate diagnosis.<br>(2)Check if the connector is loose and if the wire is broken. |
|     |                       | Red/green all LEDs are flashing.                    | Unit has failed.   | Stop the operation and contact SMC.  |
|     | DX□E<br>DX□F          | Red ST LED is ON.<br>(Diagnosis is activated)       | Diagnosis error<br>Input device power supply is short-circuited.   | Check the parts with error by using the LED display or PLC * or H.T. Re-wire the short-circuited part or check if the cable and input device are normal.   |
|     |                       | Red ST LED is flashing.<br>(Diagnosis is activated) | Diagnosis error<br>ON/OFF count of the input device has exceeded the set value.  | Check the parts with error by using the LED display or PLC * or H.T. Reset the ON/OFF count to zero or change the set value. Or invalidate diagnosis.  |
|     |                       | Red/green ST LED is flashing.                       | Unit has failed.   | Stop the operation and contact SMC.  |

\*: Refer to "System diagnosis" (page 60) for the further details.

| No. | Part No.<br>EX600- | Problem  | Presumed cause   | Troubleshooting  |
|-----|--------------------|--|--|--|
| 3   | DY□B               | Red LED is ON.<br>(Diagnosis is activated)             | Diagnosis error<br>Output device is short-circuited.   | Check the parts with error by using the LED display or PLC * or H.T. Re-wire the short-circuited part or check if the cable and output device are normal.  |
|     |                    | Red LED is flashing.<br>(Diagnosis is activated)       | Diagnosis error<br>(1)ON/OFF count of the output device has exceeded the set value.<br>(2)The wire of the output device is broken or disconnected. | Check the parts with error by using the LED display or PLC * or H.T.<br>(1)Reset the ON/OFF count to zero or change the set value. Or invalidate diagnosis.<br>(2)Check if the connector is loose and if the wire is broken. |
|     |                    | Red/green all LEDs are flashing.                       | Unit has failed.   | Stop the operation and contact SMC.  |
|     | DY□E<br>DY□F       | Red ST LED is ON.<br>(Diagnosis is activated)          | Diagnosis error<br>Output device is short-circuited.   | Check the parts with error by using the LED display or PLC * or H.T. Re-wire the short-circuited part or check if the cable and output device are normal.  |
|     |                    | Red ST LED is flashing.<br>(Diagnosis is activated)    | Diagnosis error<br>(1)ON/OFF count of the output device has exceeded the set value.<br>(2)The wire of the output device is broken or disconnected. | Check the parts with error by using the LED display or PLC * or H.T.<br>(1)Reset the ON/OFF count to zero or change the set value. Or invalidate diagnosis.<br>(2)Check if the connector is loose and if the wire is broken. |
|     |                    | Red/green ST LED is flashing.                          | Unit has failed  | Stop the operation and contact SMC.  |
| 4   | DM□E<br>DM□F       | Red ST(I) LED is ON.<br>(Diagnosis is activated)       | Diagnosis error<br>Input device power supply is short-circuited.   | Check the parts with error by using the LED display or PLC * or H.T. Re-wire the short-circuited part or check if the cable and input device are normal.   |
|     |                    | Red ST(I) LED is flashing.<br>(Diagnosis is activated) | Diagnosis error<br>ON/OFF count of the input device has exceeded the set value.  | Check the parts with error by using the LED display or PLC * or H.T.<br>Reset the ON/OFF count to zero or change the set value. Or invalidate diagnosis.   |
|     |                    | Red ST(O) LED is ON.<br>(Diagnosis is activated)       | Diagnosis error<br>Output device is short-circuited.   | Check the parts with error by using the LED display or PLC * or H.T. Re-wire the short-circuited part or check if the cable and output device are normal.  |
|     |                    | Red ST(O) LED is flashing<br>(Diagnosis is activated)  | Diagnosis error<br>(1)ON/OFF count of the output device has exceeded the set value.<br>(2)The wire of the output device is broken or disconnected. | Check the parts with error by using the LED display or PLC * or H.T.<br>(1)Reset the ON/OFF count to zero or change the set value. Or invalidate diagnosis.<br>(2)Check if the connector is loose and if the wire is broken. |
|     |                    | Red/green ST LED is flashing.                          | Unit has failed  | Stop the operation and contact SMC.  |

\*: Refer to "System diagnosis" (page 60) for the further details.

| No. | Part No.<br>EX600- | Problem  | Presumed cause   | Troubleshooting  |
|-----|--------------------|--|--|--|
| 5   | AXA                | Red LED is ON.<br>(Diagnosis is activated)       | Diagnosis error<br>Analogue input device<br>power supply is<br>short-circuited.  | Check the parts with error by using the LED display or PLC * or H.T. Re-wire the short-circuited part, and check if the cable and analogue input device are normal.  |
|     |                    | "0 and 1" red LEDs are ON.                       | Input value has exceeded the upper limit when set to current input type range.   | Check the following when the range of the analogue input unit is set to current input.<br>(1)Set the input value of the analogue input device so that it does not exceed the upper limit.<br>(2)Voltage is input from the analogue input device. Ensure the range of the input unit matches the range of the input device.   |
|     |                    | Red LED is flashing.<br>(Diagnosis is activated) | Diagnosis error<br>(1)Input value has exceeded the upper or lower limit of the range.<br>(2)Input value (value set by user) has exceeded the upper or lower limit. | (1)If the input value from the analogue input device exceeds the upper or lower limit of the range, select the appropriate range so that the input value is within the range. Or invalidate diagnosis.<br>(2)If the input value from the analogue input device exceeds the upper or lower limit of the user set value, adjust it so that the input value is within the range of the user set value. Or invalidate diagnosis. |
|     |                    | Red/green all LEDs are flashing.                 | Unit has failed  | Stop the operation and contact SMC.  |
| 6   | AYA                | Red LED is ON.<br>(Diagnosis is activated)       | Diagnosis error<br>Analogue output device<br>power supply is<br>short-circuited.   | Check the parts with error by using the LED display or PLC * or H.T. Re-wire the short-circuited part, and check if the cable and analogue output device are normal.   |
|     |                    | Red LED is flashing.<br>(Diagnosis is activated) | Diagnosis error<br>Output value (value set by user) has exceeded the upper or lower limit.   | If the output value from the analogue output device exceeds the upper or lower limit of the user set value, adjust it so that the output value is within the range of the user set value. Or invalidate diagnosis.   |
|     |                    | Red/green all LEDs are flashing.                 | Unit has failed.   | Stop the operation and contact SMC.  |

\*: Refer to "System diagnosis" (page 60) for the further details.

| No. | Part No.<br>EX600- | Problem  | Presumed cause   | Troubleshooting   |
|-----|--------------------|--|--|---|
| 7   | AMB                | Red LED is ON.<br>(Diagnosis is activated)             | Diagnosis error<br>Analogue input or output device power supply is short-circuited.  | Check the parts with error by using the LED display or PLC * or H.T. Re-wire the short-circuited part, and check if the cable and analogue input or output device are normal.   |
|     |                    | "0 and 1" red LEDs are ON.                             | Input value has exceeded the upper limit when set to Current input type range.   | Check the following when the range of the analogue input unit is set to current input.<br>(1)Set the input value of the analogue input device so that it does not exceed the upper limit.<br>(2)Voltage is input from the analogue input device. Ensure the range of the input unit matches the range of the input device.  |
|     |                    | Red LED is flashing.<br>(Diagnosis is activated)       | Diagnosis error<br>(1)Input value has exceeded the upper or lower limit of the range.<br>(2)Input or output value (value set by user) has exceeded the upper or lower limit. | (1)If the input value from the analogue input device exceeds the upper or lower limit of the range, select the appropriate range so that the input value is within the range. Or invalidate diagnosis.<br>(2)If the input (output) value from the analogue input (output) device exceeds the upper or lower limit of the user set value, adjust it so that the input (output) value is within the range of the user set value. Or invalidate diagnosis. |
|     |                    | Red/green all LEDs are flashing.                       | Unit has failed.   | Stop the operation and contact SMC.   |
| 8   |                    | Red ST(M) LED is flashing.<br>(Diagnosis is activated) | Diagnosis error (SI unit)<br>(1)Valve is short-circuited.<br>(2)Valve is open-circuited.<br>(3)ON/OFF count of the valve has exceeded the set value.                         | Check the parts with error by using the LED display or PLC * or H.T.<br>(1)Check the operation after replacing the valve.<br>(2)Check the operation after replacing the valve.<br>(3)Reset the ON/OFF count to zero or change the set value. Or invalidate diagnosis.   |
| 9   |                    | Red ST(M) LED is ON                                    | SI unit has failed.  | Stop the operation and contact SMC.   |
|     |                    | Red/green ST(M) LED is flashing alternately.           | (1)Connection between the units is defective.<br>(2)Configuration memory error.  | (1)Confirm that there is no loose connection between the units and connect them correctly.<br>(2)Unit layout is not the same as the unit layout when it was memorized. Return the layout to the same as when it was memorized, or update the configuration memory, or turn off the configuration memory function.   |
| 10  |                    | Red PWR LED is ON.<br>(Diagnosis is activated)         | Power supply voltage for control and input is abnormal.  | Supply 24 VDC $\pm$ 10% for control and input power source.   |
|     |                    | Red PWR(V) LED is ON.<br>(Diagnosis is activated)      | Power supply voltage for output is abnormal.   | Supply 24 VDC +10/-5% for output power source.  |

\*: Refer to "System diagnosis" (page 60) for the further details.



| No. | Problem                                | Presumed cause  | Troubleshooting  |
|-----|--|---|--|
| 11  | LRUN: OFF<br>LERR: OFF                 | (1)CC-Link communication failure<br>(2)PLC or SI unit malfunction                               | (1)Check the following points or reset, and then restart.<br><ul style="list-style-type: none"> <li>•Make the same communication speed of PLC and SI unit.</li> <li>•Make the same CC-Link version / number of occupied stations of PLC and SI unit.</li> <li>•Use a cable of appropriate length.</li> <li>•Use the communication cable specified for CC-Link.</li> <li>•Ensure that the cable is not broken or loose.</li> <li>•Connect terminal resistors to both ends of the network.</li> <li>•Keep noise sources away from the communication line.</li> </ul> (2)Replace the PLC or SI unit with a normal one, and check the operation. |
|     | LRUN: OFF<br>LERR: Red LED is flashing | The station number or communication speed setting switch has been changed during communication. | Cut the power supply and return the switch setting to its original condition, then supply power again.   |
|     | LRUN: OFF<br>LERR: Red LED is ON       | CC-Link communication error.  | (1)Do not set the station number to "0" or over "65".<br>Cut the power supply and reset the switch.<br>(2)Do not set the communication speed switch out of the specification range. Cut the power supply and reset the switch.<br>(3)Keep noise sources away from the communication line.  |

| No. | Problem                  | Presumed cause  | Troubleshooting  |
|-----|--------------------------|---|--|
| 12  | Abnormal valve operation | CC-Link version does not match.   | Make the CC-Link version which is set by the operation mode switch match the PLC set version. If they do not match, turn off the power, then change the set version.   |
|     |                          | The number of connected valves is larger than the number of occupied valve outputs. | When the number of occupied valves of the V_SEL switch is smaller than the number of connected valves, set the switch so that the number of occupied valves is not smaller than the number of valves to be used.   |
|     |                          | Abnormality with program, etc.  | Check if the ladder program of PLC, etc. is correct.   |
|     |                          | Abnormal power supply for output.   | Check if the green PWR(V) LED of the SI unit is ON. If the LED is OFF, or the red LED is ON, supply 24 VDC +10/-5% to the power supply for output.   |
|     |                          | Connection between SI unit and manifold valve is defective.                         | Check the connectors between the SI unit and manifold valve are not damaged, such as bent pins, and connect them correctly.  |
|     |                          | Polarity of output does not match.  | IF the polarity of the SI unit and the valve are different, replace one of them to make the combination match.<br><ul style="list-style-type: none"> <li>•EX600-SMJ1 (PNP output)<br/>⇒ -common type valve</li> <li>•EX600-SMJ2 (NPN output)<br/>⇒ +common type valve</li> </ul> |
|     |                          | SI unit has failed.   | Replace the SI unit with a normal one, and check the operation.  |
|     |                          | Valve failure.  | Replace the valve with a normal one, and check the operation. Or refer to the troubleshooting of the valve used.   |

| No. | Problem                                  | Presumed cause                                  | Troubleshooting  |
|-----|--|---|--|
| 13  | Abnormal digital input device operation  | CC-Link version does not match.                 | Make the CC-Link version which is set by the operation mode switch match the PLC set version. If they do not match, turn off the power, then change the set version. |
|     |  | Polarity of input does not match.               | If the polarity (PNP, NPN) of the input unit and the input device are different, replace one of them to make the combination match.                                  |
|     |  | Power supply for control and input is abnormal. | Check if the green PWR LED of the SI unit is ON. If the LED is OFF, or the red LED is ON, supply 24 VDC $\pm$ 10% to the power supply for control and input.         |
|     |  | Wiring or connection is defective.              | Connect the wiring correctly between the digital input device and the digital input unit.  |
|     |  | Input unit has failed.                          | Replace the input unit with a normal one, and check the operation.   |
|     |  | Input device failure.                           | Replace the input device with a normal one, and check the operation. Or refer to the troubleshooting of the input device used.                                       |
|     | Abnormal digital output device operation | CC-Link version does not match.                 | Make the CC-Link version which is set by the operation mode switch match the PLC set version. If they do not match, turn off the power, then change the set version. |
|     |  | Polarity of output does not match.              | If the polarity (PNP, NPN) of the output unit and the output device are different, replace one of them to make the combination match.                                |
|     |  | Power supply for output is abnormal.            | Check if the green PWR(V) LED of the SI unit is ON. If the LED is OFF, or the red LED is ON, supply 24 VDC $\pm$ 10/-5% to the power supply for output.              |
|     |  | Wiring or connection is defective.              | Connect the wiring correctly between the digital output device and the digital output unit.  |
|     |  | Output unit has failed.                         | Replace the Output unit with a normal one, and check the operation.  |
|     |  | Output device failure.                          | Replace the output device with a normal one, and check the operation. Or refer to the troubleshooting of the output device used.                                     |
|     |  | Program etc. is defective.                      | Check whether the ladder program etc. of PLC are correct.  |

| No.                        | Problem   | Presumed cause                                  | Troubleshooting  |
|----------------------------|---|---|--|
| 14                         | Abnormal analogue input device operation                  | CC-Link version does not match.                 | Make the CC-Link version which is set by the operation mode switch match the PLC set version. If they do not match, turn off the power, then change the set version. |
|                            |   | Power supply for control and input is abnormal. | Check if the green PWR LED of the SI unit is ON. If the LED is OFF, or the red LED is ON, supply 24 VDC $\pm 10\%$ to the power supply for control and input.        |
|                            |   | Analogue input signal range setting failure.    | Check the analogue input device specification, and set the input signal range which satisfies the specification.   |
|                            |   | Analogue data format does not match.            | Check whether the data format of the analogue input unit is properly set.  |
|                            |   | Wiring or connection is defective.              | Connect the wiring correctly between the analogue input device and the analogue input unit.  |
|                            |   | Analogue input unit has failed.                 | Replace the analogue input unit with a normal one, and check the operation.  |
|                            |   | Analogue input device failure.                  | Replace the analogue input device with a normal one, and check the operation. Or refer to the troubleshooting of the analogue input device used.                     |
|                            | Abnormal analogue output device operation                 | CC-Link version does not match.                 | Make the CC-Link version which is set by the operation mode switch match the PLC set version. If they do not match, turn off the power, then change the set version. |
|                            |   | Power supply for output is abnormal.            | Check if the green PWR(V) LED of the SI unit is ON. If the LED is OFF, or the red LED is ON, supply 24 VDC $+10/-5\%$ to the power supply for output.                |
|                            |   | Analogue output signal range setting failure.   | Check the analogue output device specification, and set the output signal range which satisfies the specification.   |
|                            |   | Analogue data format does not match.            | Check whether the data format of the analogue output unit is properly set.   |
|                            |   | Wiring or connection is defective.              | Connect the wiring correctly between the analogue output device and the analogue output unit.  |
|                            |   | Analogue output unit has failed.                | Replace the analogue output unit with a normal one, and check the operation.   |
|                            |   | Analogue output device failure.                 | Replace the analogue output device with a normal one, and check the operation. Or refer to the troubleshooting of the analogue output device used.                   |
| Program etc. is defective. | Check whether the ladder program etc. of PLC are correct. |   |  |

## Parameter Setting

The product has parameters that can be set for the system, each unit or each channel.  
The parameters can be changed using the PLC and Handheld Terminal.

- Precautions for handling
- Parameter setting by PLC is not possible for CC-Link.

### ■ Parameter definition and setting

#### • System parameters

| No. | Parameter<br>(H.T. Symbol)                     | Definition   | Item     | Content   | Default<br>setting | Parameter<br>setting |            |
|-----|--|--|----------|---|--------------------|----------------------|------------|
|     |  |  |          |   |                    | By<br>PLC            | By<br>H.T. |
| 1   | Hold/Clear<br>priority setting<br>(Hold/Clear) | Switch the setting<br>of the output during<br>communication<br>error to follow the<br>setting of the SI<br>unit or the<br>Handheld Terminal. | Switch   | Setting by SI unit switch<br>becomes valid.<br>OFF/Hold/Forced ON can<br>be set per channel         | ○                  | ×                    | ○          |
|     |  |  | Handheld | Setting by the Handheld<br>Terminal becomes valid.<br>OFF/Hold/Forced ON can<br>be set per channel. |                    |                      |            |

•SI unit parameters

| No. | Parameter<br>(H.T. Symbol)  | Definition  | Item    | Content  | Default<br>setting | Parameter<br>setting |            |
|-----|---|---|---------|--|--------------------|----------------------|------------|
|     |   |   |         |  |                    | By<br>PLC            | By<br>H.T. |
| 1   | Power supply<br>for control and<br>input voltage<br>monitor<br>(PWRC_Mon) | Error is generated<br>when control or<br>input power supply<br>voltage goes over<br>approx. 26V or<br>under 20V.              | Enable  | Enables.   | ○                  | ×                    | ○          |
|     |   |   | Disable | Disables.  |                    |                      |            |
| 2   | Power supply<br>for output<br>voltage<br>monitor<br>(PWRO_Mon)            | Error is generated<br>per unit when<br>control or output<br>power supply<br>voltage goes over<br>approx. 26V or<br>under 21V. | Enable  | Generates an error.  | ○                  | ×                    | ○          |
|     |   |   | Disable | Does not generate an<br>error.   |                    |                      |            |
| 3   | Short Circuit<br>Detection<br>(SC_MonOp)                                  | Generates error<br>per unit when the<br>short circuit of the<br>valve is detected.  | Enable  | Generates an error.  | ○                  | ×                    | ○          |
|     |   |   | Disable | Does not generate an<br>error.   |                    |                      |            |
| 4   | Restart after<br>short circuit<br>(SC_RstOp)                              | Restore the setting<br>of short circuit<br>detection error per<br>unit after the valve<br>short circuit is<br>cleared.        | Auto    | Error is automatically<br>cleared when the short<br>circuit is fixed.                                  | ○                  | ×                    | ○          |
|     |   |   | Manual  | Even when the short<br>circuit is fixed, error is not<br>cleared until the power is<br>supplied again. |                    |                      |            |
| 5   | Open Circuit<br>Detection<br>(OC_Mon)                                     | Generates error<br>per channel when<br>the disconnection<br>of the valve is<br>detected.                                      | Enable  | Generates an error.  |                    | ×                    | ○          |
|     |   |   | Disable | Does not generate an<br>error.   | ○                  |                      |            |
| 6   | Output setting<br>during<br>communication<br>fault *1<br>(Fault_MD )      | Set output per<br>channel when<br>communication is<br>abnormal.   | Clear   | Turn off the output  | ○                  | ×                    | ○          |
|     |   |   | Hold    | Hold the output  |                    |                      |            |
|     |   |   | ForceON | Turn on the output<br>forcefully   |                    |                      |            |

| No. | Parameter<br>(H.T. Symbol)              | Definition   | Item    | Content                                   | Default<br>setting | Parameter<br>setting |            |
|-----|---|--|---------|---|--------------------|----------------------|------------|
|     |   |  |         |   |                    | By<br>PLC            | By<br>H.T. |
| 7   | Valve<br>ON/OFF<br>counter<br>(Counter) | Memorizes the<br>number of times<br>the valve is ON.<br>Generates error<br>per channel when<br>the operation count<br>exceeds the set<br>value. *2 | Enable  | Generates an error.<br>Val: 1 to 65000 *3 |                    | x                    | o          |
|     |   |  | Disable | Does not generate an<br>error.            | o                  |                      |            |

\*1: This function is valid only when "Hold/Clear priority" of the system parameter is set to Handheld.

\*2: The count is memorized every 30 seconds per channel. When the power supply is turned on again, counting starts from the last value memorized.

\*3: Times for setting is set value x1000 times.

•Digital input unit parameters

| No. | Parameter<br>(H.T. Symbol)  | Definition   | Item    | Content                                    | Default<br>setting | Parameter<br>setting |            |
|-----|---|--|---------|--|--------------------|----------------------|------------|
|     |   |  |         |  |                    | By<br>PLC            | By<br>H.T. |
| 1   | The power supply short circuit detection for control and input (SC_MonSs) | Generates error per unit when the short circuit of the power supply for the input device is detected.                                | Enable  | Generates an error.                        | ○                  | ×                    | ○          |
|     |   |  | Disable | Does not generate an error.                |                    |                      |            |
| 2   | Open circuit detection *1 (OC_Mon)  | Generates error per channel when the disconnection of the input device is detected. *2   | Enable  | Generates an error.                        |                    | ×                    | ○          |
|     |   |  | Disable | Does not generate an error.                | ○                  |                      |            |
| 3   | Inrush current filter (Inrush)  | Ignores excess current per unit for 100 msec after inrush.   | Enable  | Ignores excess current.                    |                    | ×                    | ○          |
|     |   |  | Disable | Does not ignore excess current.            | ○                  |                      |            |
| 4   | Input filtering time (Filter_T)   | Sets the time to ignore the input signal change per unit.  | 0.1 ms  | Selects the time for filtering.            | 1.0 ms             | ×                    | ○          |
|     |   |  | 1.0 ms  |  |                    |                      |            |
|     |   |  | 10 ms   |  |                    |                      |            |
|     |   |  | 20 ms   |  |                    |                      |            |
| 5   | Input extension time (SigExt_T)   | Sets the time to hold the input signal per unit.   | 1.0ms   | Selects the time to hold the input signal. | 15 ms              | ×                    | ○          |
|     |   |  | 15 ms   |  |                    |                      |            |
|     |   |  | 100 ms  |  |                    |                      |            |
|     |   |  | 200 ms  |  |                    |                      |            |
| 6   | Channel ON/OFF counter (Counter)  | Memorizes the number of times the input device is ON. Generates error per channel when the operation count exceeds the set value. *3 | Enable  | Generates an error.<br>Val: 1 to 65000 *4  |                    | ×                    | ○          |
|     |   |  | Disable | Does not generate an error.                | ○                  |                      |            |

\*1: Disconnection detection is a function only available for digital unit (EX600-DXPC1, EX600-DXNC1) with disconnection detection.

\*2: 2-wire type input equipment cannot be correctly detected if its leakage current is 0.5 mA or less while the equipment is in the OFF state (reed sensor, etc.). Ensure that all input equipment used has a leakage current above 0.5 mA in the OFF state.

3-wire type input equipment cannot be correctly detected if its current consumption is 0.5mA or less. The open circuit of input signals cannot be detected.

\*3: The count is memorized every hour. When the power supply is turned on again, counting starts from the last value memorized.

\*4: Times for setting is set value x1000 times.



•Digital output unit parameters

| No. | Parameter<br>(H.T. Symbol)  | Definition   | Item    | Content  | Default<br>setting | Parameter<br>setting |            |
|-----|---|--|---------|--|--------------------|----------------------|------------|
|     |   |  |         |  |                    | By<br>PLC            | By<br>H.T. |
| 1   | Output load<br>short circuit<br>detection<br>(SC_MonOp)             | Generates error<br>per unit when the<br>short circuit of the<br>output device is<br>detected. *1   | Enable  | Generates an error.  | ○                  | ×                    | ○          |
|     |   |  | Disable | Does not generate an<br>error.   |                    |                      |            |
| 2   | Restart after<br>output load<br>short circuit<br>(SC_RstOp)         | Restore the setting<br>of short circuit<br>detection error per<br>unit after the output<br>device short circuit<br>is cleared.                             | Auto    | Error is automatically<br>cleared when the short<br>circuit is fixed.                                  | ○                  | ×                    | ○          |
|     |   |  | Manual  | Even when the short<br>circuit is fixed, error is not<br>cleared until the power is<br>supplied again. |                    |                      |            |
| 3   | Open circuit<br>detection<br>(OC_Mon)                               | Generates error<br>per channel when<br>the disconnection<br>of the output<br>device is detected.   | Enable  | Generates an error.  |                    | ×                    | ○          |
|     |   |  | Disable | Does not generate an<br>error.   | ○                  |                      |            |
| 4   | Output setting<br>during<br>communication<br>fault *2<br>(Fault_MD) | Set output per<br>channel when<br>communication is<br>abnormal.  | Clear   | Turn off the output  | ○                  | ×                    | ○          |
|     |   |  | Hold    | Hold the output  |                    |                      |            |
|     |   |  | ForceON | Turn on the output<br>forcefully   |                    |                      |            |
| 5   | Output<br>ON/OFF<br>counter<br>(Counter)                            | Memorizes the<br>number of times<br>the output device is<br>ON. Generates<br>error per channel<br>when the operation<br>count exceeds the<br>set value. *3 | Enable  | Generates an error.<br>Val: 1 to 65000 *4  |                    | ×                    | ○          |
|     |   |  | Disable | Does not generate an<br>error.   | ○                  |                      |            |

\*1: Could be incorrectly recognized as short circuit depending on used load (ex.: lamp load). If detection is incorrect, disable the parameter setting.

\*2: This function is valid only when "Hold/Clear priority" of the system parameter is set to Handheld.

\*3: The count is memorized every hour. When the power supply is turned on again, counting starts from the last value memorized.

\*4: Times for setting is set value x1000 times.

•Digital I/O unit parameters

| No. | Parameter<br>(H.T. Symbol)  | Definition  | Item    | Content   | Default<br>setting | Parameter<br>setting |            |
|-----|---|---|---------|---|--------------------|----------------------|------------|
|     |   |   |         |   |                    | By<br>PLC            | By<br>H.T. |
| 1   | The power supply short circuit detection for control and input (SC_MonSs) | Generates error per unit when the short circuit of the control or input power supply is detected.               | Enable  | Generates an error.   | ○                  | ×                    | ○          |
|     |   |   | Disable | Does not generate an error.   |                    |                      |            |
| 2   | Inrush current filter (Inrush)  | Ignores excess current per unit for 100 msec. after inrush.   | Enable  | Ignores excess current.   |                    | ×                    | ○          |
|     |   |   | Disable | Does not ignore excess current  | ○                  |                      |            |
| 3   | Input filtering time (Filter_T)   | Sets the time to ignore the input signal change per unit  | 0.1 ms  | Selects the time for filtering.   | 1.0 ms             | ×                    | ○          |
|     |   |   | 1.0 ms  |   |                    |                      |            |
|     |   |   | 10 ms   |   |                    |                      |            |
|     |   |   | 20 ms   |   |                    |                      |            |
| 4   | Input extension time (SigExt_T)   | Sets the time to hold the input signal per unit.  | 1.0 ms  | Selects the time to hold the input signal.  | 15 ms              | ×                    | ○          |
|     |   |   | 15 ms   |   |                    |                      |            |
|     |   |   | 100 ms  |   |                    |                      |            |
|     |   |   | 200 ms  |   |                    |                      |            |
| 5   | Output load short circuit detection (SC_MonOp)                            | Generates error per unit when the short circuit of the output device is detected. *1                            | Enable  | Generates an error.   | ○                  | ×                    | ○          |
|     |   |   | Disable | Does not generate an error.   |                    |                      |            |
| 6   | Restart after output load short circuit (SC_RstOp)                        | Restore the setting of short circuit detection error per unit after the output device short circuit is cleared. | Auto    | Error is automatically cleared when the short circuit is fixed.                               | ○                  | ×                    | ○          |
|     |   |   | Manual  | Even when the short circuit is fixed, error is not cleared until the power is supplied again. |                    |                      |            |
| 7   | Open circuit detection (OC_Mon)   | Generates error per channel when the disconnection of the output device is detected.                            | Enable  | Generates an error.   |                    | ×                    | ○          |
|     |   |   | Disable | Does not generate an error.   | ○                  |                      |            |
| 8   | Output setting during communication fault *2 (Fault_MD)                   | Set output per channel when communication is abnormal.  | Clear   | Turn off the output   | ○                  | ×                    | ○          |
|     |   |   | Hold    | Hold the output   |                    |                      |            |
|     |   |   | ForceON | Turn on the output forcefully   |                    |                      |            |

| No. | Parameter<br>(H.T. Symbol)                           | Definition   | Item    | Content                                   | Default<br>setting | Parameter<br>setting |            |
|-----|--|--|---------|---|--------------------|----------------------|------------|
|     |  |  |         |   |                    | By<br>PLC            | By<br>H.T. |
| 9   | Input or<br>Output<br>ON/OFF<br>counter<br>(Counter) | Memorizes the<br>number of times<br>the input or output<br>device is ON.<br>Generates error<br>per channel when<br>the operation count<br>exceeds the set<br>value. *3 | Enable  | Generates an error.<br>Val: 1 to 65000 *4 |                    | ×                    | ○          |
|     |  |  | Disable | Does not generate an<br>error.            | ○                  |                      |            |

\*1: Could be incorrectly recognized as short circuit depending on used load (ex.: lamp load). If detection is incorrect, disable the parameter setting.

\*2: This function is valid only when "Hold/Clear priority" of the system parameter is set to Handheld.

\*3: The count is memorized every hour. When the power supply is turned on again, counting starts from the last value memorized.

\*4: Times for setting is set value x1000 times.

•Analogue input unit parameters

| No.      | Parameter (H.T. Symbol)  | Definition  | Item             | Content                           | Default setting | Parameter setting |         |
|----------|--|---|------------------|-----------------------------------|-----------------|-------------------|---------|
|          |  |   |                  |                                   |                 | By PLC            | By H.T. |
| 1        | The power supply short circuit detection for the input device (SC_MonSs) | Generates error per unit when the short circuit of the power supply for the input device is detected. | Enable           | Generates an error.               | ○               | ×                 | ○       |
|          |  |   | Disable          | Does not generate an error.       |                 |                   |         |
| 2        | Analogue input range (Range)   | Set the analogue input device range per channel.  | -10..10 V        | Selects the analogue input range. | -10..10 V       | ×                 | ○       |
|          |  |   | -5..5 V          |                                   |                 |                   |         |
|          |  |   | -20..20 mA       |                                   |                 |                   |         |
|          |  |   | 0..10 V          |                                   |                 |                   |         |
|          |  |   | 0..5 V           |                                   |                 |                   |         |
|          |  |   | 1..5 V           |                                   |                 |                   |         |
|          |  |   | 0..20 mA         |                                   |                 |                   |         |
| 4..20 mA |  |   |                  |                                   |                 |                   |         |
| 3        | Analogue data format (D_Format)  | Sets analogue data type which is output to PLC per unit.  | Offset binary    | Offset binary.                    | ○               | ×                 | ○       |
|          |  |   | Sign & Magnitude | Signed binary.                    |                 |                   |         |
|          |  |   | 2S Complement    | 2's complement.                   |                 |                   |         |
| 4        | Analogue average filter (Filter)   | Sets analogue filtering time per channel. Sampling interval is approx. 2 sec.                         | None             | None                              |                 | ×                 | ○       |
|          |  |   | 2AVG             | 2 value average                   | ○               |                   |         |
|          |  |   | 4AVG             | 4 value average                   |                 |                   |         |
| 5        | Over range detection (Over_Rng)  | Generates error per unit when the input value exceeds 0.5% of full span.                              | Enable           | Generates an error.               | ○               | ×                 | ○       |
|          |  |   | Disable          | Does not generate an error.       |                 |                   |         |
|          |  |   | 8AVG             | 8 value average                   |                 |                   |         |
| 6        | Under range detection (Undr_Rng)   | Generates error per unit when the input value falls below 0.5% of full span.                          | Enable           | Generates an error.               | ○               | ×                 | ○       |
|          |  |   | Disable          | Does not generate an error.       |                 |                   |         |
| 7        | User setting value upper limit error (Upr_Lmt)                           | Generates error per unit when the input value exceeds the set value.                                  | Enable           | Generates an error. *1            |                 | ×                 | ○       |
|          |  |   | Disable          | Does not generate an error.       | ○               |                   |         |
| 8        | User setting value lower limit error (Lwr_Lmt)                           | Generates error per channel when the input value falls below the set value.                           | Enable           | Generates an error. *1            |                 | ×                 | ○       |
|          |  |   | Disable          | Does not generate an error.       | ○               |                   |         |

\*1: Set value shall be set per analogue input range within settable range in the table below. When the analogue input range is changed, check the set value and change it to an appropriate value.

| Analogue input measurement range.<br>(Range) | Upper and lower setting limit of user setting. |                     |
|--|--|---------------------|
|  | (Lwr_Lmt)                                      | (Upr_Lmt)           |
| -10..10 V                                    | -10.50 to +10.45 V                             | -10.45 to +10.50 V  |
| -5..5 V                                      | - 5.25 to + 5.22 V                             | - 5.22 to +5.25 V   |
| -20..20 mA                                   | -21.00 to +20.90 mA                            | -20.90 to +21.00 mA |
| 0..10 V                                      | 0.00 to +10.45 V                               | +0.05 to +10.50 V   |
| 0..5 V                                       | 0.00 to +5.22 V                                | +0.03 to +5.25 V    |
| 1..5 V                                       | +0.75 to +5.22 V                               | +0.78 to +5.25 V    |
| 0..20 mA                                     | 0.00 to +20.90 mA                              | +0.10 to +21.00 mA  |
| 4..20 mA                                     | +3.00 to +20.90 mA                             | +3.10 to +21.00 mA  |

•Analogue output unit parameters (1)

| No. | Parameter<br>(H.T. Symbol)  | Definition   | Item             | Content  | Default<br>setting | Parameter<br>setting |            |
|-----|---|--|------------------|--|--------------------|----------------------|------------|
|     |   |  |                  |  |                    | By<br>PLC            | By<br>H.T. |
| 1   | The power supply short circuit detection for the output device (SC_MonSs) | Generates error per unit when the short circuit of the output device is detected.                          | Enable           | Generates an error.                              | ○                  | ×                    | ○          |
|     |   |  | Disable          | Does not generate an error.                      |                    |                      |            |
| 2   | Analogue output range (Range)   | Sets the range of the analogue output device per channel.  | 0..10 V          | Selects the analogue output range.               | 0..10 V            | ×                    | ○          |
|     |   |  | 0..5 V           |  |                    |                      |            |
|     |   |  | 1..5 V           |  |                    |                      |            |
|     |   |  | 0..20 mA         |  |                    |                      |            |
|     |   |  | 4..20 mA         |  |                    |                      |            |
| 3   | Analogue data format (D_Format)   | Sets analogue data type which is output to PLC per unit.   | Offset binary    | Offset binary.                                   | ○                  | ×                    | ○          |
|     |   |  | Sign & Magnitude | Signed binary.                                   |                    |                      |            |
|     |   |  | 2S Complement    | 2's complement.                                  |                    |                      |            |
|     |   |  | Scaled           | Scale conversion type.                           |                    |                      |            |
| 4   | User setting value upper limit error (Upr_Lmt)                            | Generates error per channel when the output value exceeds the set value.                                   | Enable           | Generates an error. *2                           |                    | ×                    | ○          |
|     |   |  | Disable          | Does not generate an error.                      | ○                  |                      |            |
|     | Scale upper limit setting *1 (UpLm/Scl)                                   | Sets the scale upper limit. Generates error per channel when the output value exceeds the upper limit.     | Enable           | Generates an error. Val: -32766 to 32767         |                    |                      |            |
|     |   |  | Disable          | Does not generate an error. Val: -32766 to 32767 | ○<br>Val: 1000     |                      |            |
| 5   | User setting value lower limit error (Lwr_Lmt)                            | Generates error per channel when the output value falls below the set value.                               | Enable           | Generates an error. *2                           |                    | ×                    | ○          |
|     |   |  | Disable          | Does not generate an error.                      | ○                  |                      |            |
|     | Scale lower limit setting *1 (LwLm/Scl)                                   | Sets the scale lower limit. Generates error per channel when the output value falls below the lower limit. | Enable           | Generates an error. Val: -32767 to 32766         |                    |                      |            |
|     |   |  | Disable          | Does not generate an error. Val: -32767 to 32766 | ○<br>Val: 0        |                      |            |
| 6   | Output setting for communication fault *3 (Fault_MA)                      | Set output per channel when communication is abnormal.   | Enable           | Val is output. *2                                |                    | ×                    | ○          |
|     |   |  | Disable          | The output is held.                              | ○                  |                      |            |

- \*1: When "Scaled" is selected as the analogue data format, the display of H.T. is switched from Upr\_Lmt to UpLm/Scl, from Lwr\_Lmt to LwLm/Scl.
- \*2: Set value shall be set per analogue input range within settable range in the table below. When the analogue input range is changed, check the set value and change it to an appropriate value.
- \*3: This function is valid only when "Hold/Clear priority" of the system parameter is set to Handheld.

| Analogue output measurement range.<br>(Range) | Upper and lower setting limit of user setting. |                    | Settable range during communication fault.<br>(Fault_MA) |
|---|--|--------------------|--|
|   | (Lwr_Lmt)                                      | (Upr_Lmt)          |  |
| 0..10 V                                       | 0.00 to +10.45 V                               | +0.05 to +10.50 V  | 0.00 to +10.50 V   |
| 0..5 V  | 0.00 to + 5.22 V                               | +0.03 to +5.25 V   | 0.00 to +5.25 V  |
| 1..5 V  | +0.75 to +5.22 V                               | +0.78 to +5.25 V   | +0.75 to +5.25 V   |
| 0..20 mA                                      | 0.00 to +20.90 mA                              | +0.10 to +21.00 mA | 0.00 to +21.00 mA  |
| 4..20 mA                                      | +3.00 to +20.90 mA                             | +3.10 to +21.00 mA | +3.00 to +21.00 mA                                       |

•Analogue I/O unit parameters (1)

| No. | Parameter<br>(H.T. Symbol)   | Definition  | Item             | Content   | Default<br>setting | Parameter<br>setting |            |
|-----|--|---|------------------|---|--------------------|----------------------|------------|
|     |  |   |                  |   |                    | By<br>PLC            | By<br>H.T. |
| 1   | The power supply short circuit detection for the input or output device (SC_MonSs) | Generates error per unit when the short circuit of the input device power supply or output device is detected.  | Enable           | Generates an error.                               | ○                  | ×                    | ○          |
|     |  |   | Disable          | Does not generate an error.                       |                    |                      |            |
| 2   | Analogue input or output range (Range)   | Sets the analogue input or output device range per channel.   | 0..10 V          | Selects the analogue input or output range.       | 1.5 V              | ×                    | ○          |
|     |  |   | 0..5 V           |   |                    |                      |            |
|     |  |   | 1..5 V           |   |                    |                      |            |
|     |  |   | 0..20 mA         |   |                    |                      |            |
|     |  |   | 4..20 mA         |   |                    |                      |            |
| 3   | Analogue data format (D_Format)  | Sets analogue data type which is output to PLC per unit.  | Offset binary    | Offset binary.                                    | ○                  | ×                    | ○          |
|     |  |   | Sign & Magnitude | Signed binary.                                    |                    |                      |            |
|     |  |   | 2S Complement    | 2's complement.                                   |                    |                      |            |
|     |  |   | Scaled           | Scale conversion type.                            |                    |                      |            |
| 4   | Analogue average filter (Filter)   | Sets analogue filtering time per channel. Sampling interval is approx. 2 sec.                                   | None             | None  | ○                  | ×                    | ○          |
|     |  |   | 2AVG             | 2 value average                                   |                    |                      |            |
|     |  |   | 4AVG             | 4 value average                                   |                    |                      |            |
|     |  |   | 8AVG             | 8 value average                                   |                    |                      |            |
| 5   | Over range detection (Over_Rng)  | Generates error per unit when the input value exceeds 0.5% of full span.  | Enable           | Generates an error.                               |                    | ×                    | ○          |
|     |  |   | Disable          | Does not generate an error.                       | ○                  |                      |            |
| 6   | Under range detection (Undr_Rng)   | Generates error per unit when the input value falls below 0.5% of full span.                                    | Enable           | Generates an error.                               |                    | ×                    | ○          |
|     |  |   | Disable          | Does not generate an error.                       | ○                  |                      |            |
| 7   | User's set value upper limit error (Upr_Lmt)                                       | Generates error per channel when the input or output value exceeds the set value.                               | Enable           | Generates an error. *2                            | ○                  | ×                    | ○          |
|     |  |   | Disable          | Does not generate an error.                       |                    |                      |            |
|     | Scale upper limit setting *1 (UpLm/Scl)  | Sets the scale upper limit. Generates error per channel when the input or output value exceeds the upper limit. | Enable           | Generates an error. Val: -32766 to 32767          | ○<br>Val: 1000     |                      |            |
|     |  |   | Disable          | Does not generated an error. Val: -32766 to 32767 |                    |                      |            |



•Analogue I/O unit parameters (2)

| No. | Parameter<br>(H.T. Symbol)                                       | Definition  | Item    | Content  | Default<br>setting | Parameter<br>setting |            |
|-----|--|---|---------|--|--------------------|----------------------|------------|
|     |  |   |         |  |                    | By<br>PLC            | By<br>H.T. |
| 8   | User's set<br>value lower<br>limit error<br>(Lwr_Lmt)            | Generates error<br>per channel when<br>the input or output<br>value falls below<br>the lower limit.                                   | Enable  | Generates an error. *2                                 |                    | x                    | o          |
|     |  |   | Disable | Does not generate an<br>error.                         | o                  |                      |            |
|     | Scale lower<br>limit setting *1<br>(UpLm/Scl)                    | Sets the scale<br>lower limit.<br>Generates error<br>per channel when<br>the input or output<br>value falls below<br>the lower limit. | Enable  | Generates an error.<br>Val: -32767 to 32766            |                    |                      |            |
|     |  |   | Disable | Does not generate an<br>error.<br>Val: -32767 to 32766 | o<br>Val: 0        |                      |            |
| 9   | Output setting<br>for<br>communication<br>fault *3<br>(Fault_MA) | Set output per<br>channel when<br>communication is<br>abnormal.   | Enable  | Val is output. *2                                      |                    | x                    | o          |
|     |  |   | Disable | The output is held.                                    | o                  |                      |            |

\*1: When "Scaled" is selected as the analogue data format, the display of H.T. is switched from Upr\_Lmt to UpLm/Scl, from Lwr\_Lmt to LwLm/Scl.

\*2: Set value shall be set per analogue input/output range within settable range in the table below.

When the analogue output range is changed, check the set value and change it to an appropriate value.

\*3: This function is valid only when "Hold/Clear priority" of the system parameter is set to Handheld.

| Analogue Input or output<br>measurement range.<br>(Range) | Upper and lower setting limit of user setting. |                    | Settable range during<br>communication fault<br>(Fault_MA) |
|---|--|--------------------|--|
|   | (Lwr_Lmt)                                      | (Upr_Lmt)          |  |
| 0..10 V   | 0.00 to +10.45 V                               | +0.05 to +10.50 V  | 0.00 to +10.50 V   |
| 0..5 V  | 0.00 to +5.22 V                                | +0.03 to +5.25 V   | 0.00 to +5.25 V  |
| 1..5 V  | +0.75 to +5.22 V                               | +0.78 to +5.25 V   | +0.75 to +5.25 V   |
| 0..20 mA  | 0.00 to +20.90 mA                              | +0.10 to +21.00 mA | 0.00 to +21.00 mA  |
| 4..20 mA  | +3.00 to +20.90 mA                             | +3.10 to +21.00 mA | +3.00 to +21.00 mA   |

## I/O Map

The table below shows the occupied area for input/output of each unit of EX600.

| Unit name            | Unit part number                             | Occupied area |             |                                |                                |
|----------------------|--|---------------|-------------|--------------------------------|--------------------------------|
|                      |  | Bit area      |             | Word area                      |                                |
|                      |  | Input (RX)    | Output (RY) | Input (RWr)                    | Output (RWw)                   |
| SI unit              | EX600-SMJ□<br>(32 output)                    | -             | 32 bit      | -                              | -                              |
|                      | EX600-SMJ□<br>(24 output)                    | -             | 24 bit      | -                              | -                              |
|                      | EX600-SMJ□<br>(16 output)                    | -             | 16 bit      | -                              | -                              |
|                      | EX600-SMJ□<br>(8 output)                     | -             | 8 bit       | -                              | -                              |
| Digital input unit   | EX600-DX□B                                   | 8 bit         | -           | -                              | -                              |
|                      | EX600-DX□C                                   | 8 bit         | -           | -                              | -                              |
|                      | EX600-DX□C1<br>(With open circuit detection) | 8 bit         | -           | -                              | -                              |
|                      | EX600-DX□D                                   | 16 bit        | -           | -                              | -                              |
|                      | EX600-DX□E                                   | 16 bit        | -           | -                              | -                              |
|                      | EX600-DX□F                                   | 16 bit        | -           | -                              | -                              |
| Digital output unit  | EX600-DY□B                                   | -             | 8 bit       | -                              | -                              |
|                      | EX600-DY□E                                   | -             | 16 bit      | -                              | -                              |
|                      | EX600-DY□F                                   | -             | 16 bit      | -                              | -                              |
| Digital I/O unit     | EX600-DM□E                                   | 8 bit         | 8 bit       | -                              | -                              |
|                      | EX600-DM□F                                   | 8 bit         | 8 bit       | -                              | -                              |
| Analogue input unit  | EX600-AXA                                    | -             | -           | 2 word<br>(1 word per channel) | -                              |
| Analogue output unit | EX600-AYA                                    | -             | -           | -                              | 2 word<br>(1 word per channel) |
| Analogue I/O unit    | EX600-AMB                                    | -             | -           | 2 word<br>(1 word per channel) | 2 word<br>(1 word per channel) |

\*: Number of occupied valve outputs of EX600-SMJ□ can be changed by the switch.

•I/O map assignment

I/O map of EX600 is assigned in order starting from the unit on the end plate side.

Taking the unit layout below as an example, the input/ output map is shown below.

|           | Unit 0         | Unit 1          | Unit 2         | Unit 3        | Unit 4        | Unit 5              |       |
|-----------|----------------|-----------------|----------------|---------------|---------------|---------------------|-------|
| End plate | AXA            | AMB             | DY□B           | DX□B          | DX□D          | SMJ□                | Valve |
|           | Analogue input | Analogue output | Digital output | Digital input | Digital input | SI unit (32 output) |       |
|           | 2 word Input   | 2 word Output   | 8 bit Output   | 8 bit Input   | 16 bit Input  | 32bit Output        |       |

| Unit No. | Unit part number                 | Input / Output map |        |           |        |
|----------|----------------------------------|--------------------|--------|-----------|--------|
|          |                                  | Bit area           |        | Word area |        |
|          |                                  | RX                 | RY     | RWr       | RWw    |
| Unit 0   | Analogue input unit (EX600-AXA)  | -                  | -      | 2 word    | -      |
| Unit 1   | Analogue output unit (EX600-AMB) | -                  | -      | -         | 2 word |
| Unit 2   | Digital output unit (EX600-DY□B) | -                  | 8 bit  | -         | -      |
| Unit 3   | Digital input unit (EX600-DX□B)  | 8 bit              | -      | -         | -      |
| Unit 4   | Digital input unit (EX600-DX□D)  | 16 bit             | -      | -         | -      |
| Unit 5   | SI unit (EX600-SMJ□)             | -                  | 32 bit | -         | -      |
| Total    |                                  | 24 bit             | 40 bit | 2 word    | 2 word |

# Diagnostic

By changing the diagnosis switch, the diagnostic data shown below is assigned to the head of input word area of the input/output map. (Refer to “Setting and Adjustment” (page 19) for setting the switch)

| Diagnosis mode | Diagnostic data                                    | Diagnosis size | Diagnosis area |
|----------------|--|----------------|----------------|
| 0              | No diagnostic data                                 | 0 word         | -              |
| 1              | System diagnosis                                   | 2 word         | RWr0-RWr1      |
| 2              | System diagnosis + Unit diagnosis (Up to 10 units) | 3 word         | RWr0-RWr2      |
| 3              | System diagnosis + Unit diagnosis (Up to 64 units) | 6 word         | RWr0-RWr5      |

\*: Diagnosis mode 3 is a function for extension in the future. Do not use it now.

\*: Channel diagnosis cannot be assigned to the diagnosis area of the input. Use a Handheld Terminal (H.T.) for monitoring.

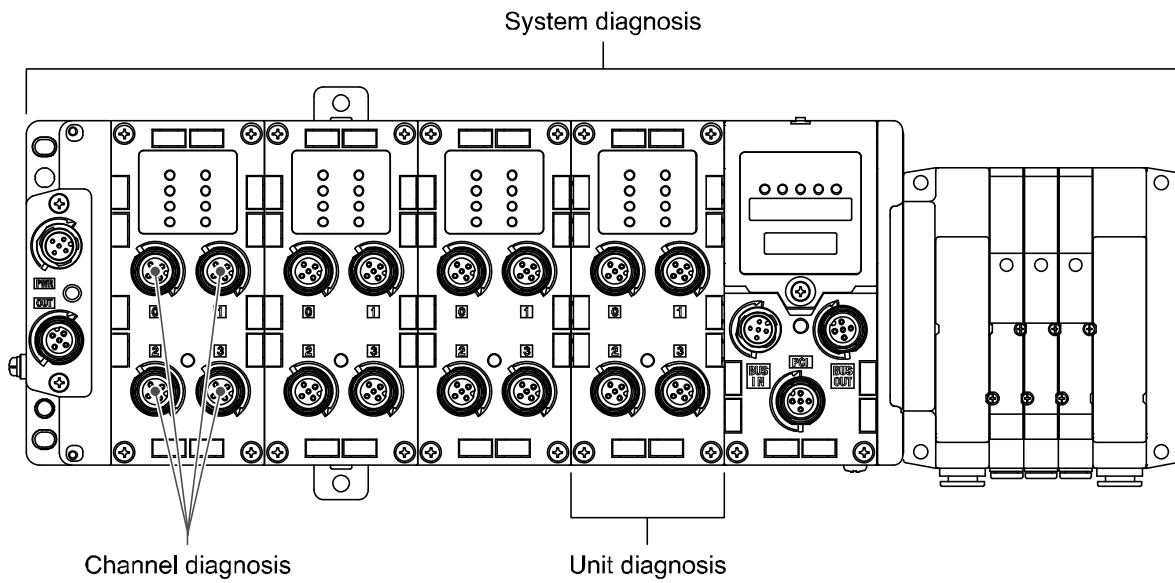

## ■Details of diagnostic data

### •System diagnosis (RWr0 to RWr1)

| Register | Bit No.  | Content of diagnosis  |
|----------|--|---|
| RWr0     | 0  | The power supply for output device is outside of the specification.                 |
|          | 1  | The power supply for control and input device is outside of the specification.      |
|          | 2  | Reserved  |
|          | 3  | There is a connection failure between each unit (During operation).                 |
|          | 4  | There is a connection failure between each unit (When the power supply is applied). |
|          | 5  | Configuration memory error occurred.  |
|          | 6  | System error occurred.  |
|          | 7  | Hardware error occurred.  |
|          | 8  | The analogue value has fallen below the user's set value.                           |
|          | 9  | The analogue value has exceeded the user's set value.                               |
|          | 10   | The analogue input value has fallen below the set range.                            |
|          | 11   | The analogue input value has exceeded the set range.                                |
|          | 12   | The counter has exceeded the set value.   |
|          | 13   | The open circuit has been detected.   |
|          | 14   | The short circuit of the valve output or digital output has been detected.          |
| 15       | The short circuit of the power supply for the input/output device has been detected. |   |
| RWr1     | 0  | There is an error in the digital input unit.*1                                      |
|          | 1  | There is an error in the digital output unit.*1                                     |
|          | 2  | There is an error in the analogue input unit.*2                                     |
|          | 3  | There is an error in the analogue output unit.*2                                    |
|          | 4  | There is an error in the SI unit.   |
|          | 5  | Reserved  |
|          | :  | :   |
|          | 15   | Reserved  |

\*1: When the error occurs in the digital I/O unit, both Bit0 and Bit1 are turned on.

\*2: When the error occurs in the analogue I/O unit, both Bit2 and Bit3 are turned on.

### •Unit diagnosis (RWr2)

| Register | Bit No. | Content of diagnosis         |
|----------|---------|------------------------------|
| RWr2     | 0       | There is an error in unit 0. |
|          | 1       | There is an error in unit 1. |
|          | 2       | There is an error in unit 2. |
|          | 3       | There is an error in unit 3. |
|          | 4       | There is an error in unit 4. |
|          | 5       | There is an error in unit 5. |
|          | 6       | There is an error in unit 6. |
|          | 7       | There is an error in unit 7. |
|          | 8       | There is an error in unit 8. |
|          | 9       | There is an error in unit 9. |
|          | 10      | Reserved                     |
|          | :       | :                            |
|          | 15      | Reserved                     |

I/O map depends on the setting of operation mode and diagnosis mode. The tables below show examples.

•Operation mode 1 (Ver.1.10, 1 station is occupied)

| Diagnosis invalid (Diagnosis mode 0 is selected)   |             |         |           | Diagnosis valid (Diagnosis mode 1 is selected) |         |          |         |             |     |        |           |     |
|--|-------------|---------|-----------|--|---------|----------|---------|-------------|-----|--------|-----------|-----|
| Station  | bit area    |         | word area |  | Station | bit area |         | word area   |     |        |           |     |
|  | RX          | RY      | RWr       | RWw  |         | RX       | RY      | RWr         | RWw |        |           |     |
| 1  | I15..I0     | O15..O0 | 0         | AI0  | AO0     | 1        | I15..I0 | O15..O0     | 0   | System | AO0       |     |
|  | System area |         | 1         | AI1  | AO1     |          | 1       | System area |     | 1      | diagnosis | AO1 |
|  |             |         | 2         | AI2  | AO2     |          | 2       |             |     | 2      | AI2       | AO2 |
|  |             |         | 3         | AI3  | AO3     |          | 3       |             |     | 3      | AI3       | AO3 |
| <p>I15..I0 : Digital input (16 inputs)<br/>                     O15..O0 : Digital output (16 inputs)<br/>                     AI3..AI0 : Analogue input (4 channels)<br/>                     AO3..AO0: Analogue output (4 channels)</p> |             |         |           |  |         |          |         |             |     |        |           |     |

•Operation mode 2 (Ver.1.10, 2 stations are occupied)

| Diagnosis invalid (Diagnosis mode 0 is selected) |             |          |           | Diagnosis valid (Diagnosis mode 2 is selected) |         |          |          |             |          |          |           |     |
|--|-------------|----------|-----------|--|---------|----------|----------|-------------|----------|----------|-----------|-----|
| Station  | bit area    |          | word area |  | Station | bit area |          | word area   |          |          |           |     |
|  | RX          | RY       | RWr       | RWw  |         | RX       | RY       | RWr         | RWw      |          |           |     |
| 1  | I15..I0     | O15..O0  | 0         | AI0  | AO0     | 1        | I15..I0  | O15..O0     | 0        | System + | AO0       |     |
|  | I31..I16    | O31..O16 | 1         | AI1  | AO1     |          | 1        | I31..I16    | O31..O16 | 1        | unit      | AO1 |
|  |             |          | 2         | AI2  | AO2     |          | 2        |             |          | 2        | diagnosis | AO2 |
|  |             |          | 3         | AI3  | AO3     |          | 3        |             |          | 3        | AI0       | AO3 |
| 2  | I47..I32    | O47..O32 | 0         | AI4  | AO4     | 2        | I47..I32 | O47..O32    | 0        | AI1      | AO4       |     |
|  | System area |          | 1         | AI5  | AO5     |          | 1        | System area |          | 1        | AI2       | AO5 |
|  |             |          | 2         | AI6  | AO6     |          | 2        |             |          | 2        | AI3       | AO6 |
|  |             |          | 3         | AI7  | AO7     |          | 3        |             |          | 3        | AI4       | AO7 |

•Operation mode 5 (Ver.2.00, 1 station is occupied, extended cyclic 4 times)

|              |           | Diagnosis invalid (Diagnosis mode 0 is selected) |          |           |      | Diagnosis valid (Diagnosis mode 1 is selected) |           |             |           |     |                  |      |   |     |     |
|--------------|-----------|--|----------|-----------|------|--|-----------|-------------|-----------|-----|------------------|------|---|-----|-----|
| 1st division | Station 1 | bit area   |          | word area |      | Station 1                                      | bit area  |             | word area |     |                  |      |   |     |     |
|              |           | RX   | RY       | RWr       | RWw  |  | RX        | RY          | RWr       | RWw |                  |      |   |     |     |
|              |           | I15..I0  | O15..O0  | 0         | AI0  |  | AO0       | I15..I0     | O15..O0   | 0   | System diagnosis | AO0  |   |     |     |
|              |           |  |          | 1         | AI1  |  | AO1       |             |           | 1   | AI0              | AO1  |   |     |     |
|              |           |  |          |           |      |  |           |             |           | 2   | AI2              | AO2  |   |     |     |
|              |           |  |          |           |      |  |           |             |           |     |                  |      | 3 | AI3 | AO3 |
| 2nd division | Station 2 | I31..I16   | O31..O16 | 0         | AI4  | AO4  | Station 2 | I31..I16    | O31..O16  | 0   | AI2              | AO4  |   |     |     |
|              |           |  |          | 1         | AI5  | AO5  |           |             |           | 1   | AI3              | AO5  |   |     |     |
|              |           |  |          | 2         | AI6  | AO6  |           |             |           | 2   | AI4              | AO6  |   |     |     |
|              |           |  |          | 3         | AI7  | AO7  |           |             |           | 3   | AI5              | AO7  |   |     |     |
| 3rd division | Station 3 | I47..I32   | O47..O32 | 0         | AI8  | AO8  | Station 3 | I47..I32    | O47..O32  | 0   | AI6              | AO8  |   |     |     |
|              |           |  |          | 1         | AI9  | AO9  |           |             |           | 1   | AI7              | AO9  |   |     |     |
|              |           |  |          | 2         | AI10 | AO10   |           |             |           | 2   | AI8              | AO10 |   |     |     |
|              |           |  |          | 3         | AI11 | AO11   |           |             |           | 3   | AI9              | AO11 |   |     |     |
| 4th division | Station 4 | System area                                      |          | 0         | AI12 | AO12   | Station 4 | System area |           | 0   | AI10             | AO12 |   |     |     |
|              |           |  |          | 1         | AI13 | AO13   |           |             |           | 1   | AI11             | AO13 |   |     |     |
|              |           |  |          | 2         | AI14 | AO14   |           |             |           | 2   | AI12             | AO14 |   |     |     |
|              |           |  |          | 3         | AI15 | AO15   |           |             |           | 3   | AI13             | AO15 |   |     |     |

•Operation mode 7 (Ver.2.00, 2 stations are occupied, extended cyclic 8 times)

|              |           | Diagnosis invalid (Diagnosis mode 0 is selected) |         |            |     | Diagnosis valid (Diagnosis mode 2 is selected) |          |           |               |     |              |     |      |      |
|--------------|-----------|--|---------|------------|-----|--|----------|-----------|---------------|-----|--------------|-----|------|------|
| 1st division | Station 1 | bit area   |         | word area  |     | Station 1                                      | bit area |           | word area     |     |              |     |      |      |
|              |           | RX   | RY      | RWr        | RWw |  | RX       | RY        | RWr           | RWw |              |     |      |      |
|              |           | I15..I0  | O15..O0 | 0          | AI0 |  | AO0      | I15..I0   | O15..O0       | 0   | System + AO0 |     |      |      |
|              |           |  |         | 1          | AI1 |  | AO1      |           |               | 1   | unit AO1     |     |      |      |
|              |           |  | 2       | AI2        | AO2 |  |          | 2         | diagnosis AO2 |     |              |     |      |      |
|              |           |  | 3       | AI3        | AO3 |  |          | 3         | AI0           | AO3 |              |     |      |      |
|              | Station 2 | I31..I16   |         | O31..O16   | 0   | AI4  | AO4      | Station 2 | I31..I16      |     | O31..O16     | 0   | AI1  | AO4  |
|              |           | I47..I32   |         | O47..O32   | 1   | AI5  | AO5      |           | I47..I32      |     | O47..O32     | 1   | AI2  | AO5  |
|              |           |  | 2       | AI6        | AO6 |  |          |           |               | 2   | AI3          | AO6 |      |      |
|              |           |  | 3       | AI7        | AO7 |  |          |           |               | 3   | AI4          | AO7 |      |      |
| 2nd division | Station 1 | I63..I48   |         | O63..O48   | 0   | AI8  | AO8      | Station 1 | I63..I48      |     | O63..O48     | 0   | AI5  | AO8  |
|              |           |  |         |            | 1   | AI9  | AO9      |           |               |     |              | 1   | AI6  | AO9  |
|              |           |  |         |            | 2   | AI10   | AO10     |           |               |     |              | 2   | AI7  | AO10 |
|              |           |  |         |            | 3   | AI11   | AO11     |           |               |     |              | 3   | AI8  | AO11 |
|              | Station 2 | I79..I64   |         | O79..O64   | 0   | AI12   | AO12     | Station 2 | I79..I64      |     | O79..O64     | 0   | AI9  | AO12 |
|              |           | I95..I80   |         | O95..O80   | 1   | AI13   | AO13     |           | I95..I80      |     | O95..O80     | 1   | AI10 | AO13 |
|              |           |  |         |            | 2   | AI14   | AO14     |           |               |     |              | 2   | AI11 | AO14 |
|              |           |  |         |            | 3   | AI15   | AO15     |           |               |     |              | 3   | AI12 | AO15 |
| ⋮            |           |  |         |            |     |  |          |           |               |     |              |     |      |      |
| 8th division | Station 1 | I351..I336                                       |         | O351..O336 | 0   | AI56   | AO56     | Station 1 | I351..I336    |     | O351..O336   | 0   | AI53 | AO56 |
|              |           |  |         |            | 1   | AI57   | AO57     |           |               |     |              | 1   | AI54 | AO57 |
|              |           |  |         |            | 2   | AI58   | AO58     |           |               |     |              | 2   | AI55 | AO58 |
|              |           |  |         |            | 3   | AI59   | AO59     |           |               |     |              | 3   | AI56 | AO59 |
|              | Station 2 | I367..I352                                       |         | O367..O352 | 0   | AI60   | AO60     | Station 2 | I367..I352    |     | O367..O352   | 0   | AI57 | AO60 |
|              |           | System area                                      |         |            | 1   | AI61   | AO61     |           | System area   |     |              | 1   | AI58 | AO61 |
|              |           |  |         |            | 2   | AI62   | AO62     |           |               |     |              | 2   | AI59 | AO62 |
|              |           |  |         |            | 3   | AI63   | AO63     |           |               |     |              | 3   | AI60 | AO63 |



## Accessories

For the selection of accessories, refer to the catalog.

### (1) Valve plate

#### EX600-ZMV1

Enclosed parts: Round head screw (M4 x 6), 2 pcs.

Round head screw (M3 x 8), 4 pcs.

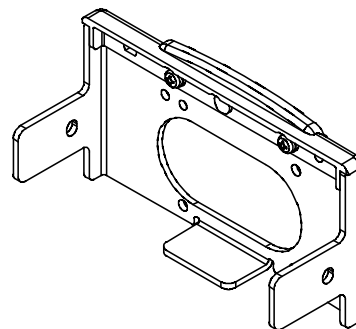

#### EX600-ZMV2 (Specified for SY series)

Enclosed parts: Round head screw (M4 x 6), 2 pcs.

Round head screw (M3 x 8), 4 pcs.

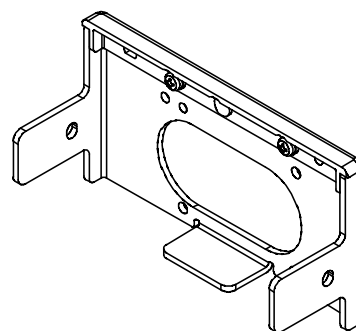

### (2) End plate bracket

#### EX600-ZMA2

Enclosed parts: Round head screw (M4 x 20), 1 pc.

P tight screw (4 x 14), 2 pcs.

#### EX600-ZMA3 (Specified for SY series)

Enclosed parts: Round head screw (M4 x 20) with washer, 1 pc.

P tight screw (4 x 14), 2 pcs.

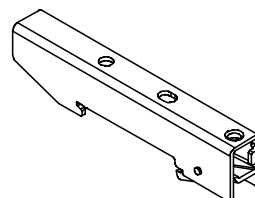

### (3) Intermediate support bracket

#### EX600-ZMB1...for direct mounting

Enclosed parts: Round head screw (M4 x 5), 2 pcs.

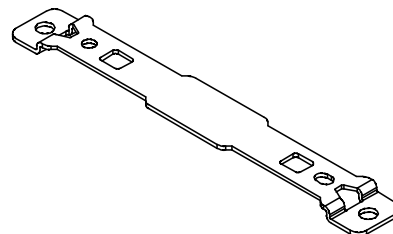

#### EX600-ZMB2...for DIN rail mounting

Enclosed parts: Round head screw (M4 x 6), 2 pcs.

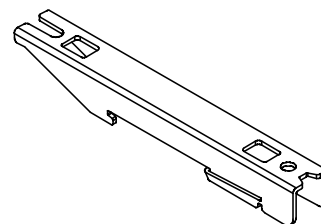

- (4) Seal cap (10 pcs.)  
EX9-AWES...for M8  
EX9-AWTS...for M12

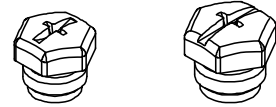

- (5) Marker (1 sheet, 88 pcs.)  
EX600-ZT1



- (6) Y Junction connector  
PCA-1557785 2 x M12 (5 pin) – M12 (5 pin)

- (7) Assembled type connector  
PCA-1578078 for power supply, 7/8 inch, Plug, Cable O.D. 12 to 14 mm  
PCA-1578081 for power supply, 7/8 inch, Socket, Cable O.D. 12 to 14 mm  
PCA-1557617 for CC-Link communication, Plug  
PCA-1557620 for CC-Link communication, Socket  
PCA-1557730 M8 (3 pin), Plug  
PCA-1557743 M12 (4 pin), Plug, for AWG26 to AWG22, SPEEDCON compatible  
PCA-1557756 M12 (4 pin), Plug, for AWG22 to AWG18, SPEEDCON compatible

- (8) Power supply cable  
PCA-1558810 Cable with 7/8 inch connector, Socket, Straight 2 m  
PCA-1558823 Cable with 7/8 inch connector, Socket, Straight 6 m  
PCA-1558836 Cable with 7/8 inch connector, Socket, Right angle 2 m  
PCA-1558849 Cable with 7/8 inch connector, Socket, Right angle 6 m  
PCA-1564927 Cable with M12 connector, B code, Socket, Straight 2 m, SPEEDOCON compatible  
PCA-1564930 Cable with M12 connector, B code, Socket, Straight 6 m, SPEEDOCON compatible  
PCA-1564943 Cable with M12 connector, B code, Socket, Right angle 2 m, SPEEDOCON compatible  
PCA-1564969 Cable with M12 connector, B code, Socket, Right angle 6 m, SPEEDOCON compatible

- (9) CC-Link communication cable  
PCA-1567720 Cable with M12 connector, A code, Socket, Straight 5 m, SPEEDOCON compatible  
PCA-1567717 Cable with M12 connector, A code, Plug, Straight 5 m, SPEEDOCON compatible

- (10) Connector extension cable  
PCA-1557769 M12 (4 pin), Straight 3 m  
PCA-1557772 M8 (3 pin), Straight 3 m

#### Revision history

A: Revision (Pollution degree)  
B: Contents revised in several places.  
C: Contents revised in several places [May 2024]

## SMC Corporation

Tel: + 81 3 5207 8249 Fax: +81 3 5298 5362  
URL <https://www.smcworld.com>

---

Note: Specifications are subject to change without prior notice and any obligation on the part of the manufacturer.  
© SMC Corporation All Rights Reserved

