



Operation Manual

PRODUCT NAME

Fieldbus system

IO-Link Master Unit

MODEL / Series / Product Number

EX600-LAB1

EX600-LBB1

SMC Corporation

Table of Contents

Safety Instructions	2
System Outline	8
Assembly	10
Mounting and Installation	12
<i>IO-Link Master Unit</i>	
Model Indication and How to Order	15
Summary of Product parts	15
Mounting and Installation	16
LED Display	17
Specification	19
Maintenance	21
Parameter Setting	22
Diagnosis	27
Accessories	29



Safety Instructions

These safety instructions are intended to prevent hazardous situations and/or equipment damage. These instructions indicate the level of potential hazard with the labels of “**Caution**,” “**Warning**” or “**Danger**.” They are all important notes for safety and must be followed in addition to International Standards (ISO/IEC)^{*)}, and other safety regulations.

*1) ISO 4414: Pneumatic fluid power - General rules and safety requirements for systems and their components
ISO 4413: Hydraulic fluid power - General rules and safety requirements for systems and their components
IEC 60204-1: Safety of machinery - Electrical equipment of machines - Part 1: General requirements
ISO 10218-1: Robots and robotic devices - Safety requirements for industrial robots - Part 1: Robots
etc.

	Danger	Danger indicates a hazard with a high level of risk which, if not avoided, will result in death or serious injury.
	Warning	Warning indicates a hazard with a medium level of risk which, if not avoided, could result in death or serious injury.
	Caution	Caution indicates a hazard with a low level of risk which, if not avoided, could result in minor or moderate injury.

Warning

1. The compatibility of the product is the responsibility of the person who designs the equipment or decides its specifications.

Since the product specified here is used under various operating conditions, its compatibility with specific equipment must be decided by the person who designs the equipment or decides its specifications based on necessary analysis and test results. The expected performance and safety assurance of the equipment will be the responsibility of the person who has determined its compatibility with the product. This person should also continuously review all specifications of the product referring to its latest catalog information, with a view to giving due consideration to any possibility of equipment failure when configuring the equipment.

2. Only personnel with appropriate training should operate machinery and equipment.

The product specified here may become unsafe if handled incorrectly. The assembly, operation and maintenance of machines or equipment including our products must be performed by an operator who is appropriately trained and experienced.

3. Do not service or attempt to remove product and machinery/equipment until safety is confirmed.

1. The inspection and maintenance of machinery/equipment should only be performed after measures to prevent falling or runaway of the driven objects have been confirmed.
2. When the product is to be removed, confirm that the safety measures as mentioned above are implemented and the power from any appropriate source is cut, and read and understand the specific product precautions of all relevant products carefully.
3. Before machinery/equipment is restarted, take measures to prevent unexpected operation and malfunction.

4. Our products cannot be used beyond their specifications. Our products are not developed, designed, and manufactured to be used under the following conditions or environments. Use under such conditions or environments is not covered.

1. Conditions and environments outside of the given specifications, or use outdoors or in a place exposed to direct sunlight.
2. Use for nuclear power, railways, aviation, space equipment, ships, vehicles, military application, equipment affecting human life, body, and property, fuel equipment, entertainment equipment, emergency shut-off circuits, press clutches, brake circuits, safety equipment, etc., and use for applications that do not conform to standard specifications such as catalogs and operation manuals.
3. Use for interlock circuits, except for use with double interlock such as installing a mechanical protection function in case of failure. Please periodically inspect the product to confirm that the product is operating properly.



Safety Instructions

Caution

We develop, design, and manufacture our products to be used for automatic control equipment, and provide them for peaceful use in manufacturing industries.

Use in non-manufacturing industries is not covered.

Products we manufacture and sell cannot be used for the purpose of transactions or certification specified in the Measurement Act.

The new Measurement Act prohibits use of any unit other than SI units in Japan.

Limited warranty and Disclaimer/Compliance Requirements

The product used is subject to the following “Limited warranty and Disclaimer” and “Compliance Requirements”.

Read and accept them before using the product.

Limited warranty and Disclaimer

1. The warranty period of the product is 1 year in service or 1.5 years after the product is delivered, whichever is first.*2)

Also, the product may have specified durability, running distance or replacement parts. Please consult your nearest sales branch.

2. For any failure or damage reported within the warranty period which is clearly our responsibility, a replacement product or necessary parts will be provided.

This limited warranty applies only to our product independently, and not to any other damage incurred due to the failure of the product.

3. Prior to using SMC products, please read and understand the warranty terms and disclaimers noted in the specified catalog for the particular products.

***2) Vacuum pads are excluded from this 1 year warranty.**

A vacuum pad is a consumable part, so it is warranted for a year after it is delivered.

Also, even within the warranty period, the wear of a product due to the use of the vacuum pad or failure due to the deterioration of rubber material are not covered by the limited warranty

Compliance Requirements

1. The use of SMC products with production equipment for the manufacture of weapons of mass destruction (WMD) or any other weapon is strictly prohibited.

2. The exports of SMC products or technology from one country to another are governed by the relevant security laws and regulations of the countries involved in the transaction. Prior to the shipment of a SMC product to another country, assure that all local rules governing that export are known and followed.

Operator

- ◆ This operation manual is intended for those who have knowledge of machinery using pneumatic equipment, and have sufficient knowledge of assembly, operation and maintenance of such equipment. Only those persons are allowed to perform assembly, operation and maintenance.
- ◆ Read and understand this operation manual carefully before assembling, operating or providing maintenance to the product.

■ Safety Instructions

Warning

- Do not disassemble, modify (including changing the printed circuit board) or repair.
An injury or failure can result.
- Do not operate or set with wet hands.
This may lead to an electric shock.
- Do not operate the product outside of the specifications.
Do not use for flammable or harmful fluids.
Fire, malfunction, or damage to the product can result.
Verify the specifications before use.
- Do not operate in an atmosphere containing flammable or explosive gases.
Fire or an explosion can result.
This product is not designed to be explosion proof.
- If using the product in an interlocking circuit:
 - Provide a double interlocking system, for example a mechanical system.
 - Check the product regularly for proper operation.Otherwise malfunction can result, causing an accident.
- The following instructions must be followed during maintenance:
 - Turn off the power supply.
 - Stop the air supply, exhaust the residual pressure and verify that the air is released before performing maintenance.Otherwise an injury can result.

Caution

- When handling the unit or assembling/replacing units:
 - Do not touch the sharp metal parts of the connector or plug for connecting units.
 - Take care not to hit your hand when disassembling the unit.
The connecting portions of the unit are firmly joined with seals.
 - When joining units, take care not to get fingers caught between units.
An injury can result.

- After maintenance is complete, perform appropriate functional inspections.
Stop operation if the equipment does not function properly.
Safety cannot be assured in the case of unexpected malfunction.

- Provide grounding to assure the noise resistance of the Fieldbus system.
Individual grounding should be provided close to the product with a short cable.

■ **NOTE**

- Follow the instructions given below when designing, selecting and handling the product.
 - The instructions on design and selection (installation, wiring, environment, adjustment, operation, maintenance, etc.) described below must also be followed.
 - *Product specifications
 - The direct current power supply to combine should be UL1310 Class 2 power supply when conformity to UL is necessary.
 - Use the specified voltage.
Otherwise failure or malfunction can result.
 - Reserve a space for maintenance.
Allow sufficient space for maintenance when designing the system.
 - Do not remove any nameplates or labels.
This can lead to incorrect maintenance, or misreading of the operation manual, which could cause damage or malfunction to the product.
It may also result in non-conformity to safety standards.
 - Beware of inrush current when the power supply is turned on.
Some connected loads can apply an initial charge current which will activate the over current protection function, causing the unit to malfunction.

●Product handling

*Installation

- Do not drop, hit or apply excessive shock to the SI unit.

Otherwise damage to the product can result, causing malfunction.

- Tighten to the specified tightening torque.

If the tightening torque is exceeded the mounting screws may be broken.

IP67 protection cannot be guaranteed if the screws are not tightened to the specified torque.

- If a large manifold valve is mounted, lift the unit so that stress is not applied to the connecting part while transporting.

The stress may cause breakage of the connecting part. The unit may become very heavy depending on the combination. Transportation/installation shall be performed by multiple operators.

- Never mount a product in a location that will be used as a foothold.

The product may be damaged if excessive force is applied by stepping or climbing onto it.

*Wiring

- Avoid repeatedly bending or stretching the cables, or placing heavy load on them.

Repetitive bending stress or tensile stress can cause breakage of the cable.

- Wire correctly.

Incorrect wiring can break the product.

- Do not perform wiring while the power is on.

Otherwise damage to the SI unit and/or input or output device can result, causing malfunction.

- Do not route wires and cables together with power or high voltage cables.

Otherwise the SI unit and/or input or output device can malfunction due to interference of noise and surge voltage from power and high voltage cables to the signal line.

Route the wires (piping) of the SI unit and/or input or output device separately from power or high voltage cables.

- Confirm proper insulation of wiring.

Poor insulation (interference from another circuit, poor insulation between terminals, etc.) can lead to excess voltage or current being applied to the product, causing damage.

- Take appropriate measures against noise, such as using a noise filter, when the Fieldbus system is incorporated into equipment.

Otherwise noise can cause malfunction.

*Environment

- Select the proper type of protection according to the environment of operation.

IP67 protection is achieved when the following conditions are met.

(1) The units are connected properly with fieldbus cable with M12 connector and power cable with M12 (M8) connector.

(2) Suitable mounting of each unit and manifold valve.

(3) Be sure to fit a waterproof cap on any unused connectors.

If using in an environment that is exposed to water splashes, please take measures such as using a cover.

Do not use in an environment where moisture or water vapor are present. Otherwise failure and malfunction can result.

- Do not use in a place where the product could be splashed by oil or chemicals.

If the product is to be used in an environment containing oils or chemicals such as coolant or cleaning solvent, even for a short time, it may be adversely affected (damage, malfunction etc.).

- Do not use the product in an environment where corrosive gases or fluids could be splashed.

Otherwise damage to the product and malfunction can result.

- Do not use in an area where surges are generated.

If there is equipment generating large surge near the unit (magnetic type lifter, high frequency inductive furnace, welding machine, motor, etc.), this can cause deterioration of the internal circuitry element of the unit or result in damage. Take measures against the surge sources, and prevent the lines from coming into close contact.

- When a surge-generating load such as a relay, valve or lamp is driven directly, use a product with a built-in surge absorbing element.
Direct drive of a load generating surge voltage can damage the unit.
- The product is CE/UKCA marked, but not immune to lightning strikes. Take measures against lightning strikes in the system.
- Prevent foreign matter such as dust or wire debris from getting inside the product.
- Mount the product in a place that is not exposed to vibration or impact.
Otherwise failure or malfunction can result.
- Do not use the product in an environment that is exposed to temperature cycle.
Heat cycles other than ordinary changes in temperature can adversely affect the inside of the product.
- Do not expose the product to direct sunlight.
If using in a location directly exposed to sunlight, shade the product from the sunlight.
Otherwise failure or malfunction can result.
- Keep within the specified ambient temperature range.
Otherwise malfunction can result.
- Do not operate close to a heat source, or in a location exposed to radiant heat.
Otherwise malfunction can result.

*Adjustment and Operation

- Set the switches by using a sharp-pointed screwdriver etc. When setting the switch, do not touch other unrelated parts.
This can cause parts damage or malfunction due to a short circuit.
- Perform settings suitable for the operating conditions.
Incorrect setting can cause operation failure.
- Please refer to the PLC manufacturer's manual etc. for details of programming and addresses.
For the PLC protocol and programming refer to the relevant manufacturer's documentation.

*Maintenance

- Turn off the power supply, stop the supplied air, exhaust the residual pressure and verify the release of air before performing maintenance.
There is a risk of unexpected malfunction.
- Perform regular maintenance and inspections.
There is a risk of unexpected malfunction.
- After maintenance is complete, perform appropriate functional inspections.
Stop operation if the equipment does not function properly.
Otherwise safety is not assured due to an unexpected malfunction or incorrect operation.
- Do not use solvents such as benzene, thinner etc. to clean each unit.
They could damage the surface of the body and erase the markings on the body.
Use a soft cloth to remove stains.
For heavy stains, use a cloth soaked with diluted neutral detergent and fully squeezed, then wipe up the stains again with a dry cloth.

System Outline

System configuration

The EX600 range of units can be connected to various types of fieldbus to realize the reduction of input or output device wiring and the distributed control system.

The unit communicates with the fieldbus through the SI unit.

One SI unit can be connected with manifold valves with up to 32 outputs and the input • output • I/O • IO-Link master units with maximum 10 units.

Maximum numbers of connected IO-Link master units depend on the type of SI unit.

Refer to SI unit Operation Manual of protocol used for the further details.

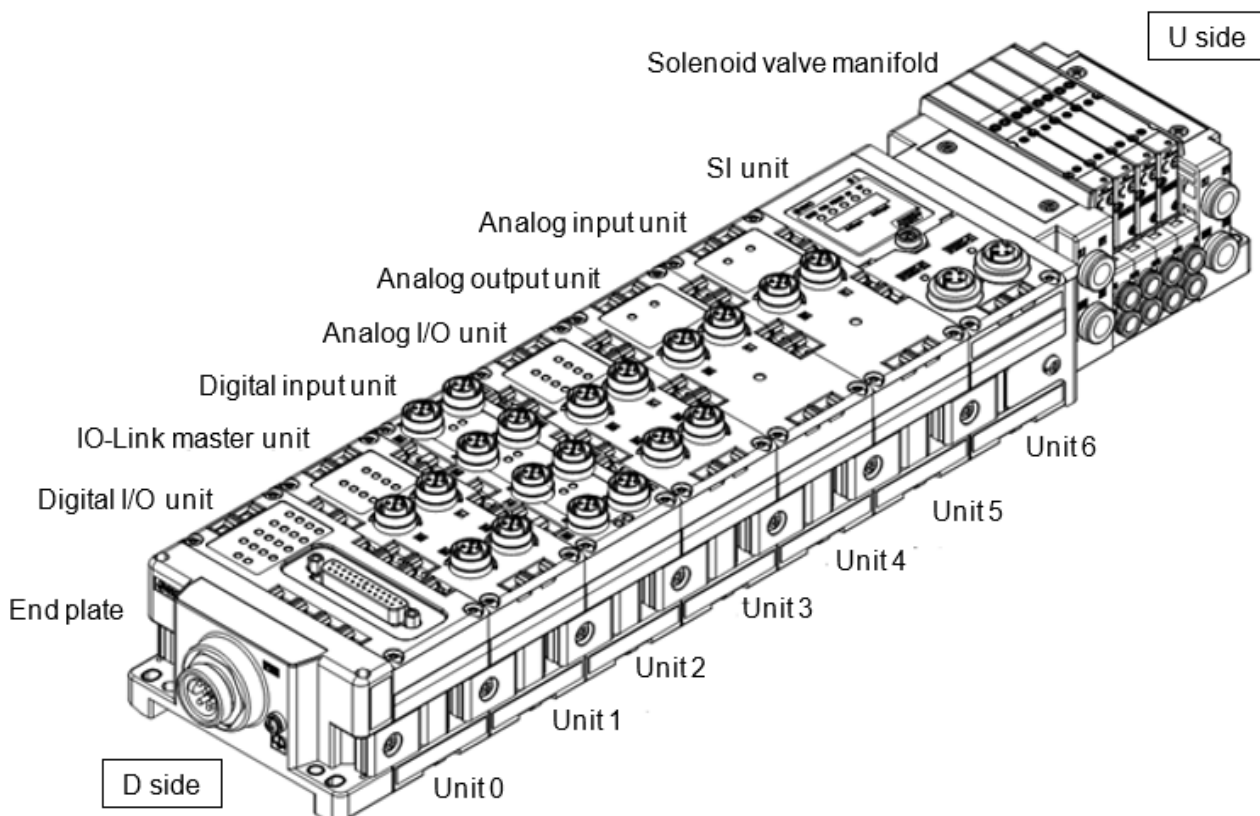

Name	Function
SI unit	Performs fieldbus communication and solenoid valve manifold ON/OFF output.
Digital input unit	For connecting sensors with switch output capability. PNP and NPN types are available.
Digital output unit	For connecting output device such as solenoid valves, lamps, buzzers, etc. PNP and NPN types are available.
Digital I/O unit	This unit has both digital input and output functions. PNP and NPN types are available.
Analogue input unit	For connecting sensors with analogue output capability.
Analogue output unit	This can be connected to the equipment which can read analogue input.
Analogue I/O unit	This unit has both analogue input and output functions.
IO-Link master unit	Compatible with IO-Link devices. There are two port types, class A and class B.
End plate	Connected at EX600 Manifold's D side, incorporating the power supply connection.
Solenoid valve manifold	An assembly of solenoid valves. One connector is used as the electric connection to all connected valves.

■ Definition and terminology

	Terminology	Definition
D	DHCP	The protocol which automatically set the information such as IP address which needs to be registered in order to use the network. Those information are set to each equipment which are connected to TCP/IP network.
E	Enclosure (IP□□)	Abbreviation of international (ingress) protection. A standard related to the protection from external objects (hands, steel ball, steel wire, dust, water, etc.) applied to the product.
F	FE	Abbreviation of functional earth.
	Fieldbus	The protocol that uses digital communication to exchange signals between field equipment (instruments and actuators) running on site and a PLC.
I	Idle	Expression for PLC operation state. For details, Refer to manuals of each PLC maker. Depending on which PLC is used; the idle state might not be available.
M	Manifold	A form consisting of multiple components. A form made by combining multiple components.
N	Number of inputs	The number of points that can receive information from input device (sensor, switch, etc.).
	Number of outputs	The number of points that can operate output device (solenoid valve, light, motor, etc.).
	Open circuit detection	A diagnosis function to detect if the input or output device wiring is disconnected.
P	PLC	Abbreviation of programmable logic controller. A digital computer used for automation of electromechanical processes.
	PNP input	Takes the sensor output that uses the PNP transistor to the signal output part.
	PNP output	The output type that uses a PNP transistor to operate output device. It is also known as a negative common type since a negative potential is applied to the power supply line.
Q	Short circuit detection	A diagnosis function to detect an over current due to the short circuit of the output and/or power supply positive line with respect to the GND line.
S	Short circuit protection	A function to protect the internal circuit from being broken by an over current due to the short circuit of the output and/or power supply positive line with respect to the GND line.
	SI unit	Abbreviation of serial interface unit. A unit connected to a PLC to communicate input and output data.
U	U Side	The side connected to the solenoid valve when the product is connected to a manifold.

Assembly

● Composing the unit as a manifold

*: If the unit was purchased as a manifold, the work described in this section is not necessary.

(1) Connect the unit to the end plate.

The Digital unit, Analogue unit can be connected in any order.

(Tightening torque: 1.5 to 1.6Nm)

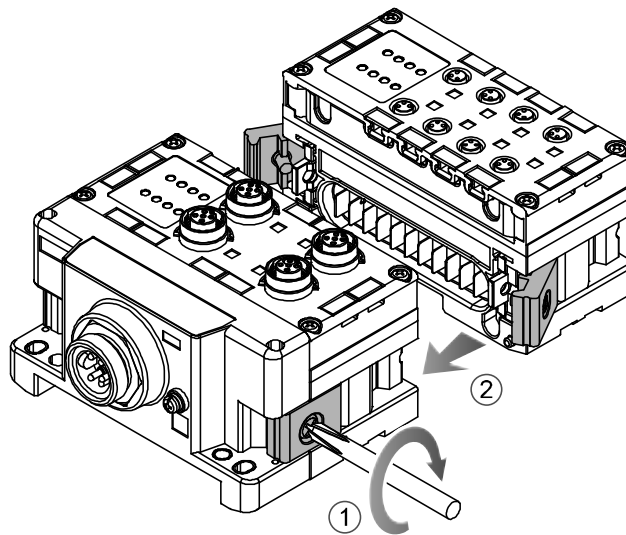

(2) Add more units.

Up to 10 units (including the SI unit) can be connected to one manifold.

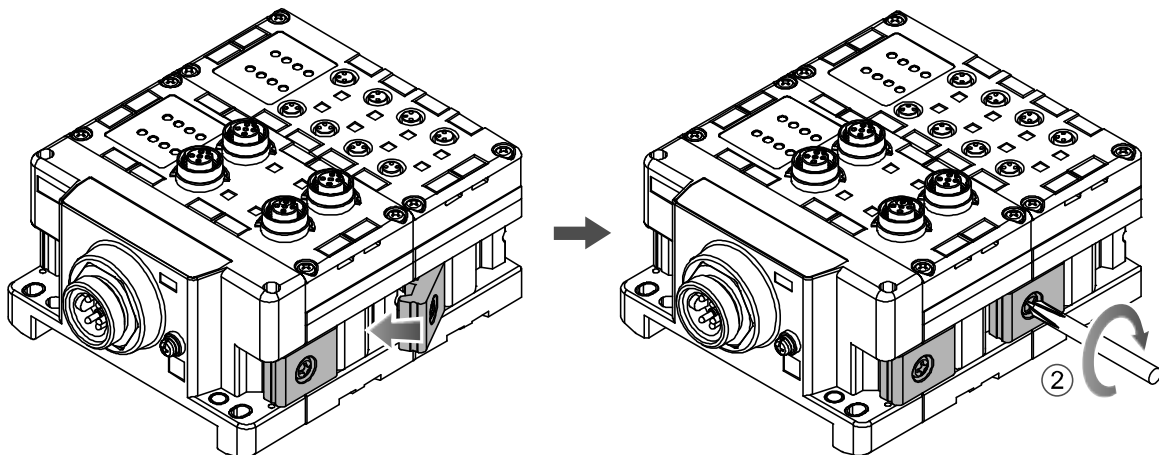

(3) Connecting the SI unit.

After connecting the necessary units, connect the SI unit.

Connecting method is the same as above (1), (2).

(4) Mounting the valve plate.

Mount the valve plate (EX600-ZMV#) to the valve manifold using the valve set screws. (M3 x 8)
(Tightening torque: 0.6 to 0.7 Nm)

Screw mounting place	
SV	: 2 places
S0700	: 2 places
VQC1000	: 2 places
VQC2000	: 3 places
VQC4000	: 4 places
SY	: 2 places
JSY	: 2 places

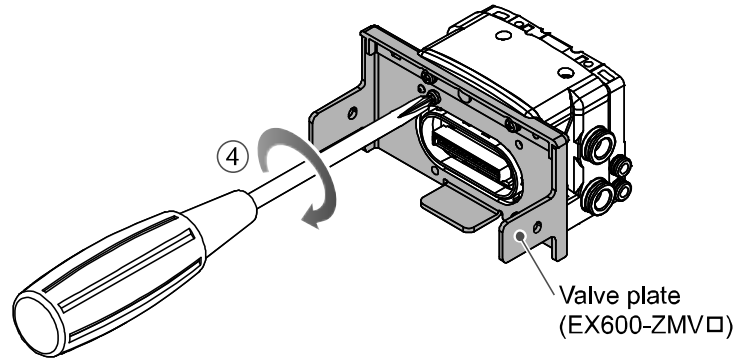

(5) Connect the SI unit and the valve manifold.

Insert the valve plate to the valve plate set groove on the side of SI unit.
Then, tighten it with the valve plate set screws (M4 x 6) to fix the plate.
(Tightening torque: 0.7 to 0.8 Nm)

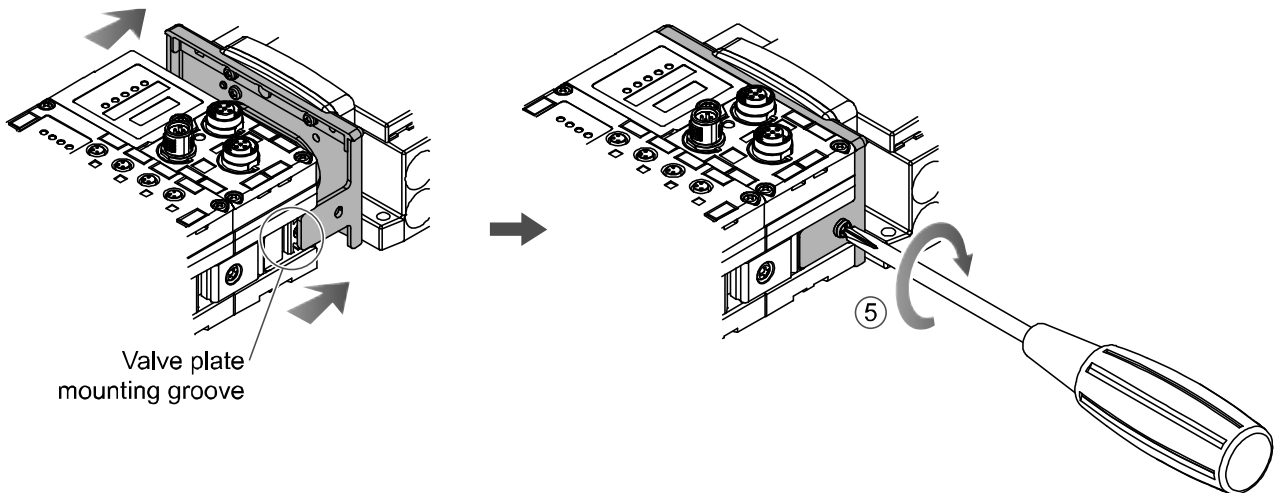

● Precautions for handling

- Please do not connect the unit while the power supply is active. It will cause equipment damage.
- Take care not to drop the nuts of Joint bracket.
- Tighten the screws to the specified torque.
Insufficient tightening may lead to equipment malfunction, injury or equipment damage.

Mounting and Installation

■ Installation

• Direct mounting

(1) Direct mounting

When joining six or more units, fix the middle part of the complete EX600 unit with an intermediate reinforcing brace (EX600-ZMB1) before mounting using 2-M4 x 5 screws.
(Tightening torque: 0.7 to 0.8 Nm)

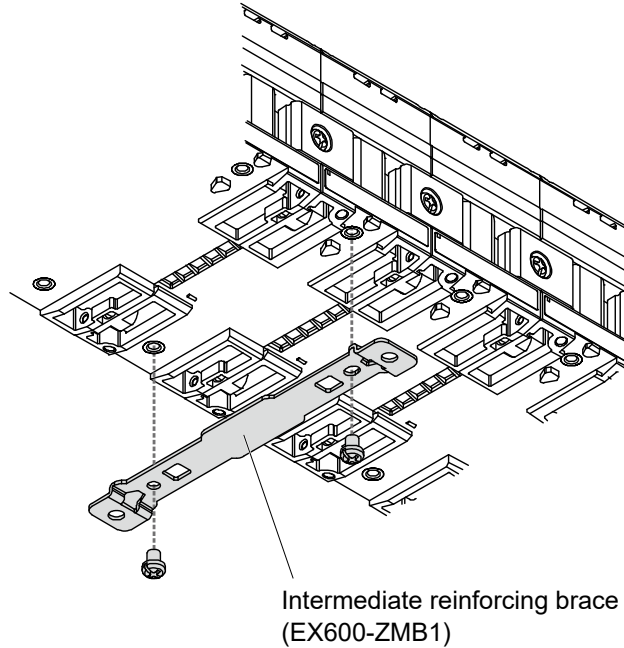

(2) Fix and tighten the end plates at one end of the unit. (M4)

(Tightening torque: 0.7 to 0.8 Nm)

Fix the end plate at the valve side while referring to the operation manual of the corresponding valve manifold.

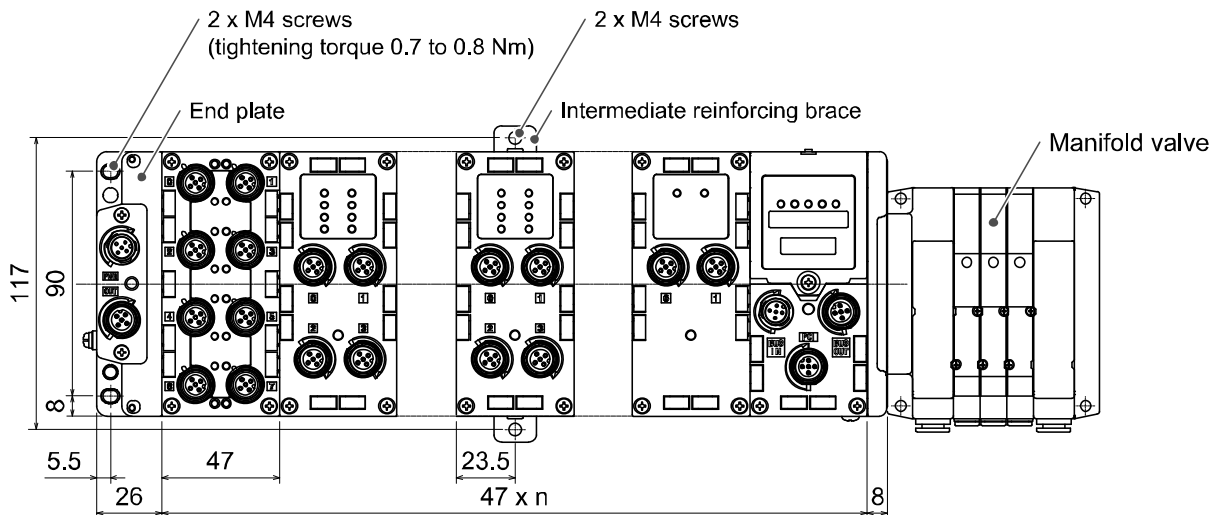

● Precautions for handling

- When joining six or more units, fix the middle part of the complete unit with an intermediate reinforcing brace to prevent incorrect connection between the units due to deflection.

•DIN rail mounting

(Not available for SY series valves. Refer to the SY catalog.)

- (1) When joining six or more units, fix the middle part of the complete EX600 unit with an intermediate reinforcing brace (EX600-ZMB2) before mounting, using 2-M4 x 6 screws. (Tightening torque: 0.7 to 0.8 Nm)
- (2) Mount the end plate bracket (EX600-ZMA2) to the end plate at the opposite end to the valves, using 2-M4 x 14 screws. (Tightening torque: 0.7 to 0.8 Nm)

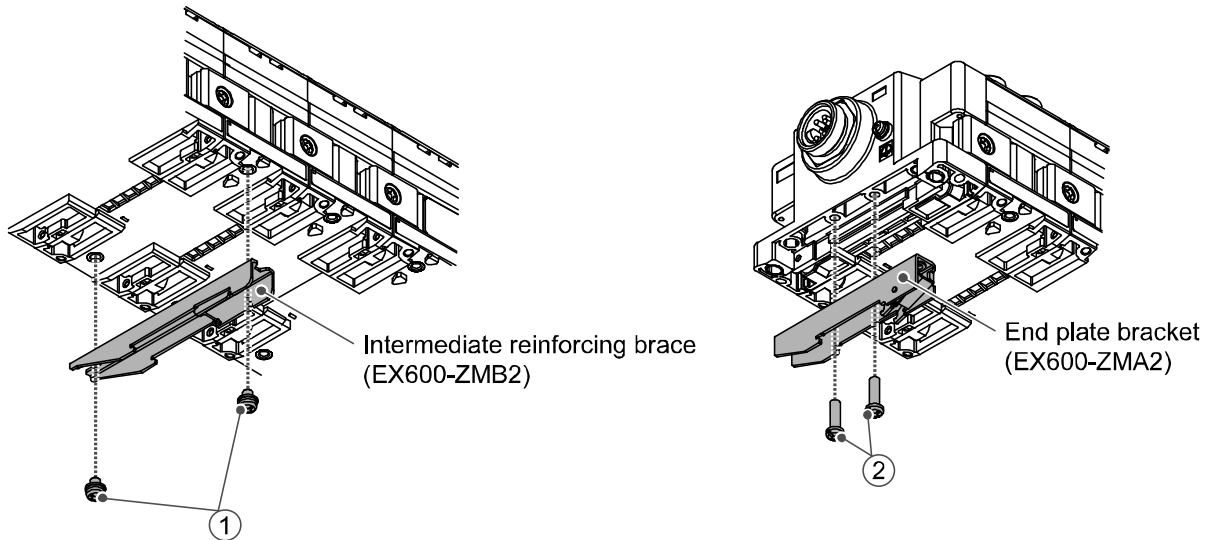

- (3) Hook the DIN rail mounting groove to the DIN rail.
- (4) Press the manifold using its side hooked to the DIN rail as a fulcrum until the manifold is locked.
- (5) Fix the manifold by tightening the DIN rail fixing screws of the EX600-ZMA2. (M4 x 20)
(Tightening torque: 0.7 to 0.8 Nm)

The tightening torque at the valve side depends on the valve type.
Refer to the operation manual of the corresponding valve manifold.

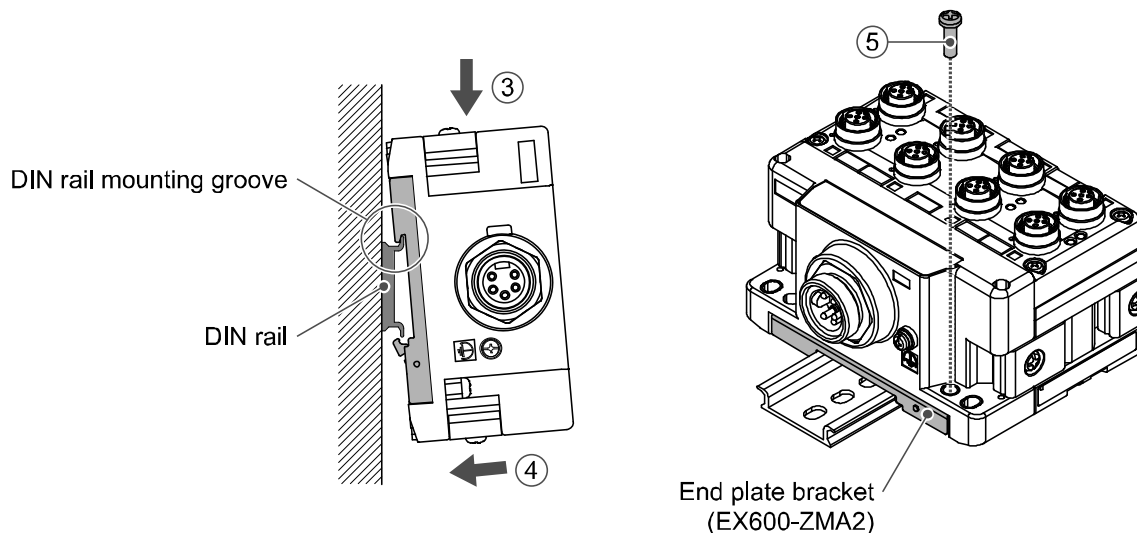

•Precautions for handling

- When joining six or more units, fix the middle part of the complete unit with an intermediate reinforcing brace to prevent incorrect connection between the units due to deflection.

■Wiring

•Connect the M12 or M8 connector cable

M12 connector is applicable for SPEEDCON connector. SPEEDCON connector wiring method is explained below.

(1) Align the mark B on the metal bracket of the cable side connector (plug/socket) with the mark A.

(2) Align the mark C on the unit and insert the connector into the unit vertically.

If they are not aligned, the connector cannot be joined properly.

(3) When the mark B of the connector has been turned 180 degrees (1/2 turn), wiring is completed.

Confirm that the connection is not loose. If turned too far, it will become hard to remove the connector.

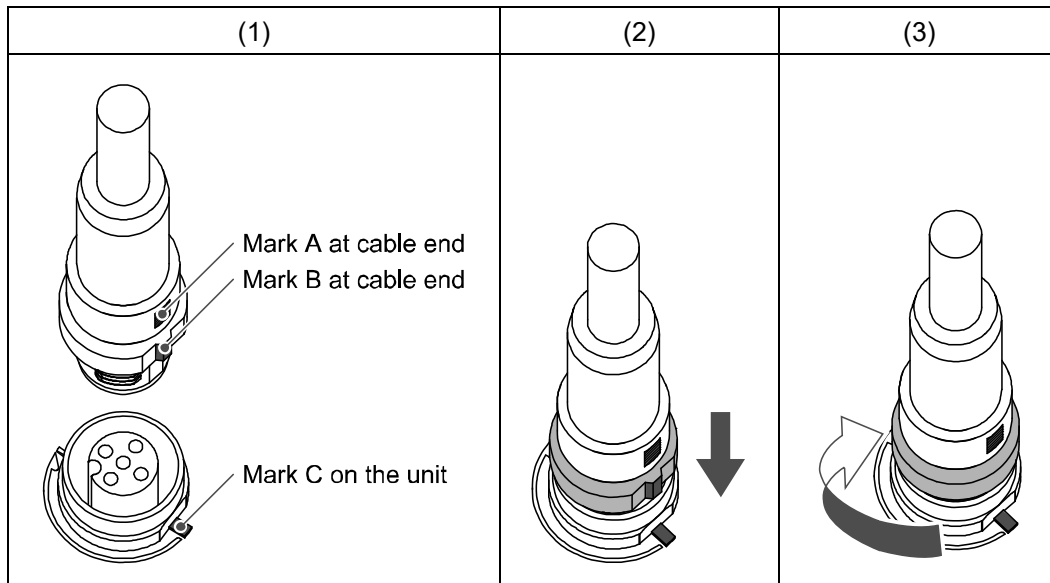

•Mounting the marker

Signal name of the input or output devices and unit address can be written to the marker, and it can be installed to each unit.

Mount the marker (EX600-ZT1) into the marker groove as required.

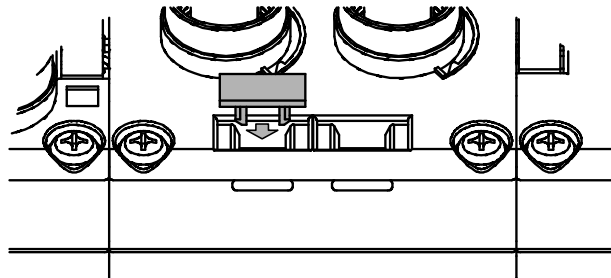

IO-Link Master Unit

Model Indication and How to Order

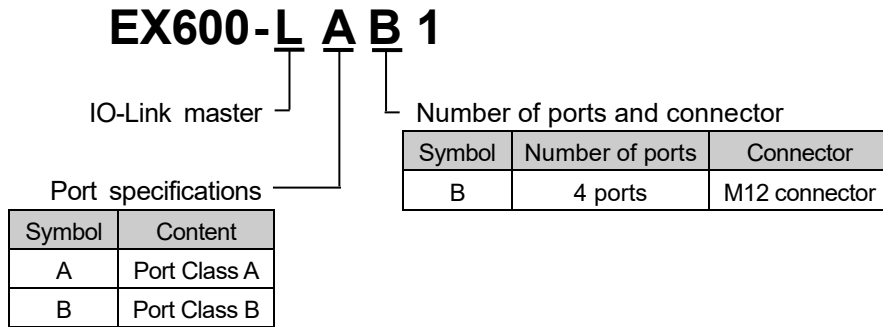

Summary of Product parts

•EX600-L#B1

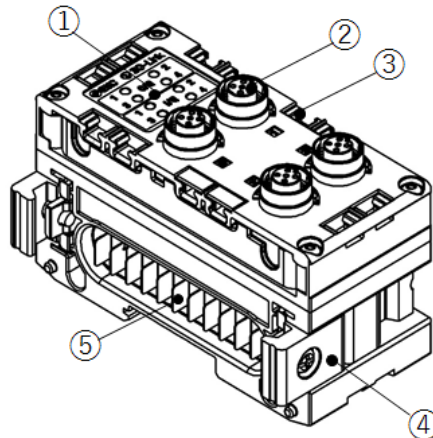

No.	Description	Function
1	Status LED's	LED display to indicate the unit status.
2	Connector	For connecting IO-Link devices.
3	Marker groove	Groove to mount a marker.
4	Joint bracket	For connecting to other units.
5	SI unit connector (plug)	Transfers signals and supplies power to the next unit.

Mounting and Installation

■Wiring

○Connector pin assignment

(1) EX600-LAB1

M12 5-pin Socket

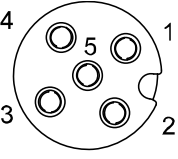
Configuration	Pin No.	Signal name	Details
	1	L+	24 V (Control and input)
	2	I/Q	Digital input (PNP)
	3	L-	0 V (Control and input)
	4	C/Q	IO-Link communication, Digital input (PNP) or Digital output (PNP) *1
	5	N.C.	Not used

*1: Can be changed with parameters. Digital output power supply is used for control / input.

(2) EX600-LBB1

M12 5-pin Socket

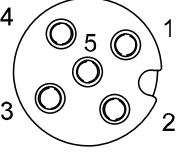
Configuration	Pin No.	Signal name	Details
	1	L+	24 V (Control and input)
	2	P24	24 V (Output)
	3	L-	0 V (Control and input)
	4	C/Q	IO-Link communication, Digital input (PNP) or Digital output (PNP) *1
	5	N24	0 V (Output)

*1: Can be changed with parameters. Digital output power supply is used for control / input.

The relationship between connector No. and IO-Link port is shown below.

Connector No.	IO-Link port No.
0	1
1	2
2	3
3	4

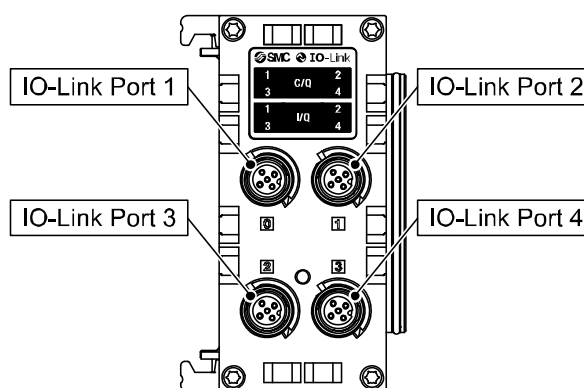

●Precautions for handling

Be sure to fit a seal cap on any unused connectors. Proper use of the seal cap enables the enclosure to achieve IP67 specification.

LED display

The LED displays the status of Pin No.4 (C/Q) and Pin No.2 (I/Q or P24) of each IO-Link port of the SI unit. The figures below show the status of each port.

•EX600-LAB1

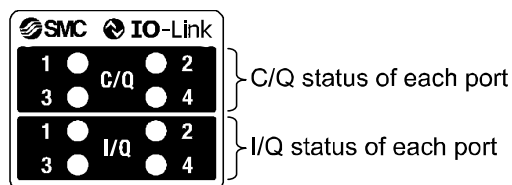

•EX600-LBB1

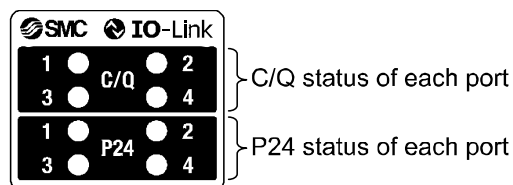

Common for IO-Link port No. 1, 2, 3 and 4 (C/Q: Pin No.4) of EX600-LAB1 and EX600-LBB1



The LED status varies depending on the setting of Pin No.4 (disabled, IO-Link communication, digital I/O) of ports No. 1 to 4.

Pin function	LED status	Details
Deactivated (Port disabled)	○ OFF	Port disabled
	● Red ON	Short circuit detection (L+)
IO-Link (IO-Link communication)	☼ Green flashing (ON/OFF: 1 Hz)	IO-Link device disconnected
	☼ Green flashing (ON/OFF: 2 Hz)	Either of the following conditions are detected: •Connected IO-Link device matching error. •Data size error. •Data storage writing error.
	● Green ON	IO-Link device communicating
	● Red ON	Short circuit detection (L+ or C/Q)
DI (Digital input)	○ OFF	Input signal OFF
	● Orange ON	Input signal ON
	● Red ON	Short circuit detection (L+)
DO (Digital output)	○ OFF	Output signal OFF
	● Orange ON	Output signal ON
	● Red ON	Short circuit detection (L+ or C/Q)

*: Refer to troubleshooting (SI unit Operation Manual of protocol used) for the further details of countermeasures.



LED 1, 2, 3, 4 (I/Q: Pin No. 2) for EX600-LAB1

The LED displays the status of Pin No.2 (Digital input) of each IO-Link port.

Pin function	LED status	Details
DI (Digital input)	 OFF	Input signal OFF
	 Orange ON	Input signal ON

LED 1, 2, 3, 4 (P24: Pin No. 2) for EX600-LBB1

The LED displays the status of Pin No.2 (Power supply for output) of each IO-Link port.

Pin function	LED status	Details
P24 (Power supply for output)	 OFF	Power supply for output OFF
	 Green ON	Power supply for output ON
	 Red ON	Short circuit detection (P24)

All LEDs Common for EX600-LAB1 and EX600-LBB1

Pin function	LED status	Details
Condition of all pins	 Red/green flashing alternately	Internal memory error

*: Refer to troubleshooting (SI unit Operation Manual of protocol used) for the further details of countermeasures.

Specification

Specifications

Model		EX600-LAB1		EX600-LBB1
Port class		Class A		Class B
Transmission speed		COM1 (4.8 kbps), COM2 (38.4 kbps), COM3 (230.4 kbps) Automatically switches depending on the device connected		
IO-Link version		Version 1.1		
Number of ports		4		
Power supply for control and inputs Max. supply current (between L+ and L-)		0.5 A / connector (2 A / unit)		0.5 A / connector (1 A / unit)
Power supply for output Max. supply current (between P24 and N24)		-		1.6 A / connector 3 A / unit
Digital input	Pin No.	2	4	4
	Input polarity	PNP		
	Protection	Short circuit protection		
	ON input current	Typ. 2.5 mA	Typ. 5.8 mA	Typ. 5.8 mA
	ON voltage	13 V or more		
	OFF voltage	8 V or less		
Digital output	Pin No.	4		
	Output type	PNP		
	Max. load current (C/Q line)	0.25 A / output (Supplied from the power supply for control / input)		
	Over current protection	Built-in short circuit prevention		
Current consumption		50 mA or less		
Operating temperature range		-10 to 50 °C		
Storage temperature range		-20 to 60 °C		
Enclosure		IP67 (manifold assembly) *2		
Standard		CE/UKCA marked, UL (CSA)		

*1: All unused connectors must have a seal cap fitted.

Regarding the 2 types of power supply

- Power supply for control and input: Supplying power for control of IO-Link master unit power supply for control and also for IO-Link device connected to IO-Link port via L+ and L- pins. (both EX600-LAB1 and EX600-LBB1)
- Power supply for output: Supplying power for IO-Link device connected to IO-Link port via P24 and N24 pins. (EX600-LBB1 only)

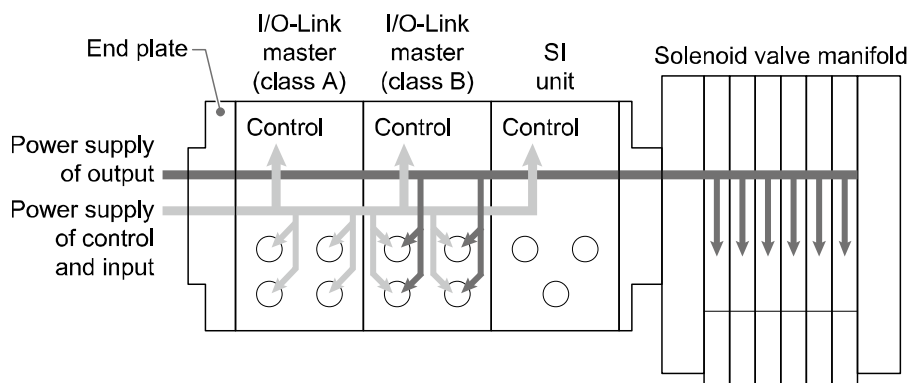

■Dimensions

•EX600-L#B1

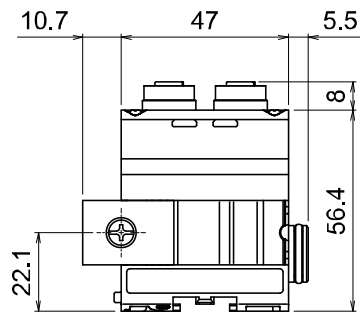
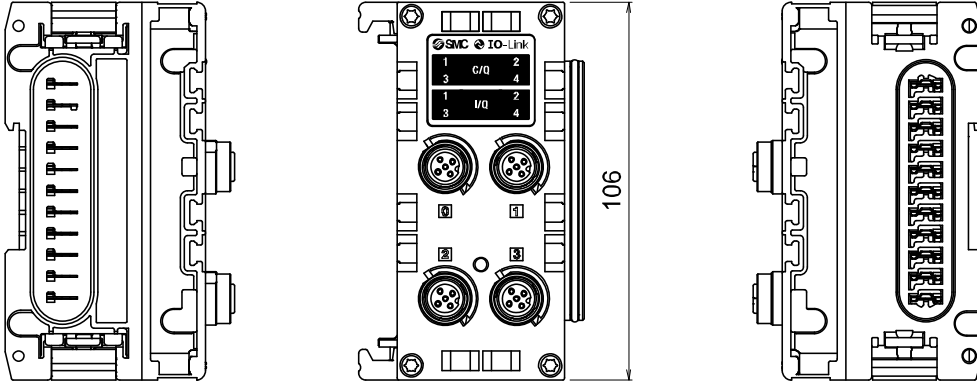

Maintenance

Turn OFF the power supply, stop the supplied air, exhaust the residual pressure and verify the release of air before performing maintenance.

Cleaning method

Use a soft cloth to remove stains.

For heavy stains, use a cloth soaked with diluted neutral detergent and fully squeezed, then wipe up the stains again with a dry cloth.

Do not use solvents such as benzene, thinner etc. to clean each unit.

Inspection item	Content of inspection
Connector/Electric wiring	Connect properly if the connection is loose.
Seal cap	Tighten properly if the connection is loose.
Thread for mounting and installation	If the thread is loose, re-tighten it to the specified torque.
Connection cables	If the cable is broken or any other abnormality is confirmed by appearance, replace the cable with a new one.
Supply source voltage	Check if source voltage within the specification range (24 VDC \pm 10%) is supplied.

How to reset the product for power cut or forcible de-energizing

Supply power to the product.

The output status just before the power failure is not maintained when power supply is recovered.

Start operation after confirming safety of the entire equipment.

Parameter Setting

IO-Link master unit parameters can be configured for the each unit and each channel. Parameters can be changed for example, by Explicit message (EtherNet/IP™) or GSDML file (PROFINET). Refer to SI unit Operation Manual of protocol used for the further details.

•IO-Link master unit parameters

No.	Parameter	Definition	Item	Content	Default setting
1	Process Data size	Set the process data size of each port of the IO-Link master.	1 to 32 byte *1	Set the I/O size of each IO-Link port.	2 byte / 2 byte
2	In / Out Byte Swap *2	Swap the byte order of the process data, which is sent and received between Fieldbus communication and IO-Link communication.	direct	Data order is not swapped.	○
			swap 16 bit	Swap in the word unit.	
			swap 32 bit	Swap in the double word unit.	
			swap All	Swap all bytes.	
3	Short Circuit Monitor	Either of the following detects the short-circuit, diagnostics is generated. •L+ power supply •C/Q signal •P24 power supply	Enable	Diagnostics is generated.	○
			Disable	Diagnostics is not generated.	
4	Output setting during Communication error (IO-Link) *3	Set the IO-Link communication process data output when the Fieldbus communication is in error.	Clear/ PD Out valid	All outputs are turned OFF while maintaining the process data output valid.	
			Hold	Maintain the process data output that the IO-Link master finally receives while maintaining the process data output valid.	
			Clear/ PD Out invalid	All outputs are turned OFF while maintaining the process data output invalid.	○

•IO-Link master unit parameters (continued)

No.	Parameter	Definition	Item	Content	Default setting
5	Output setting during Communication error (DO_C/Q)	Set the digital output signal when fieldbus communication is in error.	Clear	Turn OFF the digital output.	○
			Hold	Maintain the digital output that the IO-Link master finally receives.	
			Force ON	Turn ON the digital output.	
6	Output setting during Communication Idle*3*4 (IO-Link)	Set the IO-Link communication process data output when fieldbus communication is in idle.	Clear/ PD Out valid	All outputs are turned OFF while maintaining the process data output valid.	
			Hold	Maintain the process data output that the IO-Link master finally receives while maintaining the process data output valid.	
			Clear/ PD Out invalid	All outputs are turned OFF while maintaining the process data output invalid.	○
7	Output setting during Communication Idle*4 (DO_C/Q)	Set the digital output signal when fieldbus communication is in idle.	Clear	Turn OFF the digital output.	○
			Hold	Maintain the digital output that the IO-Link master finally receives.	
			Force ON	Turn ON the digital output.	
8	Port mode	Set the operation mode of each port.	Deactivated	Deactivate the port.	○
			IOL_Manual	Start-up IO-LINK communication based on the IO-Link device comparison function.	
			IOL_Autostart	Start up the IO-Link communication instead of comparing IO-Link device.	
			DI_C/Q	Digital input only.	
			DO_C/Q	Digital output only.	

•IO-Link master unit parameters (continued)

No.	Parameter	Definition	Item	Content	Default setting
9	Validation & Backup *5	Set the function of the comparison function (comparison of vendor ID and device ID) of the connected device and data storage (DS).	No Device Check	Comparison function: invalid DS function: invalid	○
			Type compatible Device V1.0	Connected device: V1.0 Comparison function: valid DS function: invalid	
			Type compatible Device V1.1	Connected device: V1.1 Comparison function: valid DS function: invalid	
			Type compatible Device V1.1, Backup+Restore	Connected device: V1.1 Comparison function: valid DS function: Valid (Backup & restore)	
			Type compatible Device V1.1, Restore	Connected device: V1.1 Comparison function: valid DS function: valid (for restore only)	
10	PortCycle Time	Set the IO-Link device and communication cycle time.	0.4 to 132.8 m	0: Automatic setting 0.4-6.3 ms (by 0.1 ms) 6.4-31.6 ms (by 0.4 ms) 32-132.8 ms (by 1.6 ms)	0
11	VendorID	Set the vendor ID which is compared when the IO-Link device comparison function is valid.	0x0001 to 0xFFFF	Set the vendor ID of the device to be connected.	0x0001
12	DeviceID	Set the device ID which is compared when the IO-Link device comparison function is valid.	0x000001 to 0xFFFFFFFF	Set the device ID of the device to be connected.	0x000001
13	L+Control *6	Turn ON/OFF the L+ power supply.	ON	Turn ON the L+ power supply.	○
			OFF	Turn OFF the L+ power supply.	

*1: The I/O size that can be set differs depending on the SI unit model. Refer to SI unit Operation Manual of protocol used for the further details.

*2: The available byte swap parameters vary depending on the process data of the device to be connected. Refer to I/O byte swap function for details.

*3: Refer to Output setting / IO-LINK communication mode when fieldbus communication error is generated or idling for difference in operation of the connected device due to difference in setting.

*4: PROFINET compatible SI unit does not support idle mode.

*5: Valid when the IO-Link port operation mode is in "IOL_Manual".

*6: This function supports EX600-LBB1 only.

Output setting / IO-LINK communication mode when fieldbus communication is in error or idle

When fieldbus communication is in error or idle, the connected device will operate as follows based on the IO-Link master setting.

IO-Link master setting (Output setting when fieldbus communication is in error or idle)		Operation of the connected device
Setting item	Details	
Clear/PD Out valid	All outputs are turned OFF while maintaining the process data output valid.	Output is cleared.
Hold	Maintain the process data output that the IO-Link master finally receives from the master while maintaining the process data output valid.	Output is held.
Clear/PD Out invalid	All outputs are turned OFF while maintaining the process data output invalid.	Based on the output setting function when the IO-Link communication error is generated.

*: PROFINET compatible SI unit does not support idle mode.

I/O byte swap function

•Data construction in each setting

The data construction of each parameter of the byte swap function is as follows based on the connected device process data size and the mapping size of the master communication process data.

When the process data size of the connected device and mapping size of the master communication process data are identical

(E.g.: connected device process data size: 8-byte, mapping size: 8-byte)

Parameter	Data construction
direct	0x0123 4567 89AB CDEF
swap 16bit	0x2301 6745 AB89 EFC D
swap 32bit	0x6745 2301 EFC D AB89
swap All	0xEFC D AB89 6745 2301

*: When the mapping size is 2-byte, even though the swap is set to 32bit, the byte will not be swapped.

When the process data size of the connected device and mapping size of the master communication process data are different

(E.g.: connected device process data size: 10-byte, mapping size: 16-byte)

Parameter	Data construction
direct	0x0123 4567 89AB CDEF GHIJ 0000 0000 0000
swap 16bit	0x2301 6745 AB89 EFC D IJGH 0000 0000 0000
swap 32bit	0x6745 2301 EFC D AB89 0000 IJGH 0000 0000
swap All	0x0000 0000 0000 IJGH EFC D AB89 6745 2301

*: When the mapping size is 2-byte, even though the swap is set to 32bit, the byte will not be swapped.

*: When the mapping size of the master connection process data and the process data size of the connected device are different, swap the byte including the blank byte zero.

Data storage function

When the IO-Link port operation mode is set to "IOL_Manual", and in addition to this, when Validation & Backup is set to "Type compatible, Device V1.1, Backup + Restore" or "Type compatible, Device V1.1, Restore", the data storage function is available.

- Outline of backup or re-storage

The parameter set data in each IO-Link device can be stored (referred to as "backup") in the IO-Link master. When the IO-Link device is replaced with a device with the same model, it is possible to set parameter data, which has been backed up in the IO-Link master, can be transferred from the IO-Link master to the IO-Link device (referred to as "restore").

- Condition of the backup / restore operation when the IO-Link communication starts up

The data storage function operation will be as follows based on the condition of the data storage of the IO-Link master and parameter change of the IO-Link device.

Validation & Backup set value	Condition			Data storage operation
	Data storage function	Backup requirement from the device	Checksum of the data storage and device parameter	
No Device Check	-	-	-	Cleared
Type compatible, Device V1.0	-	-	-	Cleared
Type compatible, Device V1.1	-	-	-	Cleared
Type compatible, Device V1.1, Backup + Restore	Data exists	Required	-	Backup
	Data exists	No requirement	Not identical	Restore
	Data exists	Required	Identical	Nothing occurs
	No data	-	-	Backup
Type compatible, Device V1.1, Restore	Data exists	-	Not identical	Restore
	Data exists	-	Identical	Nothing occurs
	No data	-	-	Nothing occurs

Note 1) When the vendor ID or device ID are changed, the data storage will be cleared.

Note 2) When the IO-Link port operation mode is changed to a setting other than "IOL_Manual", Validation & Backup values are automatically changed to "No Device Check". Therefore, the data storage is cleared.

Diagnosis

■Diagnosis of IO-Link master unit data

The EX600 IO-Link master unit has a diagnostic function on each port.

The diagnostics contents are displayed by LEDs and are assigned to the input process data as Port Status (PQI).

- The details of PQI are shown in the table below.

Bit	Description	Details	Value
0	ID-Mismatch	Connection device matching error	0: Match 1: Mismatch
1	PDmapping-Mismatch	Process data mapping size error *1	0: Set size or less 1: Exceeding size
2	PwrShort	L+ short circuit or P24 short circuit	0: No short circuit 1: Short circuited
3	CQShort	C/Q short circuit	0: No short circuit 1: Short circuited
4	DSSstatus	Data storage (DS) saved	0: DS saved data error, no DS data 1: DS saved data is valid
5	DevCom	Port communication status	0: Device not connected 1: Operation or preparation
6	DevErr	Event (Device or master event status)	0: No event or notification 1: Warning or Error
7	PQ	Received input process data Valid (normal) / invalid (abnormal) *2	0: Invalid (abnormal) 1: Valid (normal)

*1: An error is detected when the process data size of the actually connected device exceeds the size which is set in the process data mapping.

*2: Process data is maintained when the received input process data is abnormal (Process Data Invalid).

Port diagnostics function	Details	Port LED status	PQI Bit No. (Description)	Event code
L+ short circuit detection	Pin No. 1-3 short circuit diagnostics	Red ON	2 (PwrShort)	0x1806
P24 short circuit detection	Pin No. 2-5 short circuit diagnostics	Red ON	2 (PwrShort)	0x180F
C/Q short circuit	Pin No. 1-4 or 3-4 short circuit diagnostics	Red ON	3 (CQShort)	0x1804 0x1813
Connected device matching error	When the port operation mode is IO-Link, the communication port in which "matching level of connected device" parameter is set to "Type Compatible" matches the registered Vendor ID, Device ID and the value read from the connected device, and if they are not matched, an error is diagnosed.	Green flashing	0 (ID Mismatch)	0x1803
Device process data mapping error *1	When the port operation mode is set to IO-Link, if a device in which the process data length is longer than the mapped data length is connected, it will be diagnosed as an error.	Green flashing	1 (PDmapping-Mismatch)	0x1F01
Device disconnection is detected *2	When the pin function / operation mode is set to IO-Link, device disconnection is detected.	Green flashing	5 (DevCom)	0x1800
P24 power supply reduction	Power supply reduction of class B type Pin No. 2-5 is diagnosed.	OFF (P24)	-	0x180E

*1: Under the mapping error, all of the process data input and output are zero.

*2: When Device disconnected is detected at port, all of the process data input is zero.

Note) Diagnostics other than the short circuit detection (L+, P24, C/Q) are not handled as the EX600 diagnostic data, so check for the LED display and PQI of the IO-Link master.

Accessories

For the selection of accessories, refer to the catalog.

(1) Intermediate support bracket

EX600-ZMB1: For direct mounting

Enclosed parts: Round head screw (M4 x 5), 2 pcs.

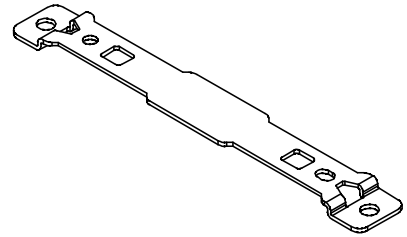

EX600-ZMB2: For DIN rail mounting

Enclosed parts: Round head screw (M4 x 6), 2 pcs.

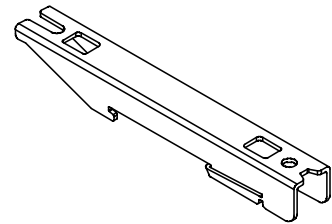

(2) Seal cap (10 pcs.)

EX9-AWTS: For M12



(3) Marker (1 sheet, 88 pcs.)

EX600-ZT1

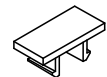

(4) IO-Link communication cable

EX9-AC005-SSPS: Cable with M12 connector, Socket, Plug, Straight 0.5 m

EX9-AC010-SSPS: Cable with M12 connector, Socket, Plug, Straight 1.0 m

EX9-AC020-SSPS: Cable with M12 connector, Socket, Plug, Straight 2.0 m

EX9-AC030-SSPS: Cable with M12 connector, Socket, Plug, Straight 3.0 m

EX9-AC050-SSPS: Cable with M12 connector, Socket, Plug, Straight 5.0 m

EX9-AC100-SSPS: Cable with M12 connector, Socket, Plug, Straight 10.0 m

Revision history
A: Contents revised in several places [May 2024]

SMC Corporation

Tel: + 81 3 5207 8249 Fax: +81 3 5298 5362

URL <https://www.smcworld.com>

Note: Specifications are subject to change without prior notice and any obligation on the part of the manufacturer.
© SMC Corporation All Rights Reserved

