



Operation Manual

PRODUCT NAME

Safety IO module

MODEL / Series / Product Number

EX600-FVC1
EX600-FVC2
EX600-FVC3
EX600-FVC4

SMC Corporation

IMPORTANT

This product is intended to be used in applications requiring the safe removal of the electrical energizing supply to valve manifold and evaluate of signals of connected input equipment (e.g., sensors).

It is the user's responsibility to determine if this product is suitable for the intended application and to specify the arrangement of the safety system to achieve the required safety function.

This manual is only valid for the EX600-FVC# series with the following product versions.

Table 0-1.1-1: Applicable products

Product number	Protocol	Product version
<ul style="list-style-type: none">• EX600-FVC1• EX600-FVC2• EX600-FVC3• EX600-FVC4	CIP Safety™	1X / YY

**The original language of the Safety Manual is English.
Manuals that have been translated into other languages should be used for reference only.**

Contents

IMPORTANT	2
Safety Instructions	5
1. For your safety	12
1.1. Purpose of this manual	12
1.2. Validity of the user manual	12
1.3. Residual Risks.....	12
1.3.1. Risk of injury	12
1.3.2. Loss of safety function.....	12
1.3.3. Operating time in the error state	13
1.4. General safety notes	13
1.4.1. Qualified personnel.....	13
1.4.2. Documentation	13
1.4.3. Safety of personal and equipment	13
1.4.4. Error detection	13
1.4.5. Maintenance and Repairs	13
1.4.6. Do not carry out any repairs or modifications	13
1.4.7. Product Replacement.....	14
1.4.8. Product Disposal	14
1.4.9. Mismatching and polarity reversal of connections	14
1.5. Electrical safety	14
1.5.1. Direct/indirect contact.....	14
1.5.2. Power supply units for 24V supply	14
1.5.3. Insulation rating	14
1.6. Safety of the machine or system.....	15
1.6.1. Draw up and implement a safety concept.....	15
1.6.2. Validate hardware and parameterization.....	15
1.7. Directive and standards	16
1.7.1. Intended use	16
1.8. Abbreviations used.....	16
2. Product outline	17
2.1. Features	17
2.1.1. Features of the Safety IO module	17
2.2. Safety function overview	17
2.2.1. Safety inputs.....	17
2.2.2. Safety outputs.....	19
2.3. Structure	20
2.4. Product type	22
2.5. LED indicators.....	22
3. Installation	26
3.1. Composing the module as a manifold	26
3.2. Dimensions.....	28
3.3. Connectors	29
4. Commissioning.....	30
4.1. Configuration	30
4.2. Safety communication.....	31
4.2.1. Establishing safety communication	31
4.2.2. Safety reset on CIP safety.....	32
4.3. Process data	33
4.3.1. Safe process data.....	33
4.3.2. Non-safety process data	36
4.4. Parameterization	38
4.4.1. Safe parameterization	38
4.4.2. Non-safety parameterization	42
4.5. Safety inputs.....	43

4.5.1.	Power supply for sensors	43
4.5.2.	Safety input.....	44
4.6.	Safety outputs	46
4.7.	Solenoid valve and ITV module	46
4.8.	Diagnostics.....	47
4.8.1.	Safety related diagnostics	47
4.8.2.	Error reset for safety related diagnostics	49
4.8.3.	Non-safety diagnostics and Error reset for non-safety related diagnostics	49
5.	Technical specifications	50
5.1.	Safety specifications	50
5.2.	General specifications	51
5.3.	Production label	52
5.4.	Block diagrams.....	53
6.	Appendix	55
6.1.	Checklists.....	55
6.2.	Troubleshooting.....	59
6.2.1.	Fault mode.....	60
6.3.	Safety integrity level with the system.....	71
6.3.1.	Safety inputs.....	71
6.3.2.	Safety outputs.....	74
6.3.3.	Safety input and Safety output	74
6.4.	Glossary	75
6.5.	Accessories.....	75



Safety Instructions

These safety instructions are intended to prevent hazardous situations and/or equipment damage. These instructions indicate the level of potential hazard with the labels of “Caution,” “Warning” or “Danger.” They are all important notes for safety and must be followed in addition to International Standards (ISO/IEC)*1), and other safety regulations.

*1) ISO 4414: Pneumatic fluid power - General rules and safety requirements for systems and their components
ISO 4413: Hydraulic fluid power - General rules and safety requirements for systems and their components
IEC 60204-1: Safety of machinery - Electrical equipment of machines - Part 1: General requirements
ISO 10218-1: Robots and robotic devices - Safety requirements for industrial robots - Part 1: Robots
etc.

	Danger	Danger indicates a hazard with a high level of risk which, if not avoided, will result in death or serious injury.
	Warning	Warning indicates a hazard with a medium level of risk which, if not avoided, could result in death or serious injury.
	Caution	Caution indicates a hazard with a low level of risk which, if not avoided, could result in minor or moderate injury.

Warning

- 1. The compatibility of the product is the responsibility of the person who designs the equipment or decides its specifications.**
Since the product specified here is used under various operating conditions, its compatibility with specific equipment must be decided by the person who designs the equipment or decides its specifications based on necessary analysis and test results. The expected performance and safety assurance of the equipment will be the responsibility of the person who has determined its compatibility with the product. This person should also continuously review all specifications of the product referring to its latest catalog information, with a view to giving due consideration to any possibility of equipment failure when configuring the equipment.
- 2. Only personnel with appropriate training should operate machinery and equipment.**
The product specified here may become unsafe if handled incorrectly. The assembly, operation and maintenance of machines or equipment including our products must be performed by an operator who is appropriately trained and experienced.
- 3. Do not service or attempt to remove product and machinery/equipment until safety is confirmed.**
 1. The inspection and maintenance of machinery/equipment should only be performed after measures to prevent falling or runaway of the driven objects have been confirmed.
 2. When the product is to be removed, confirm that the safety measures as mentioned above are implemented and the power from any appropriate source is cut, and read and understand the specific product precautions of all relevant products carefully.
 3. Before machinery/equipment is restarted, take measures to prevent unexpected operation and malfunction.
- 4. Our products cannot be used beyond their specifications. Our products are not developed, designed, and manufactured to be used under the following conditions or environments. Use under such conditions or environments is not covered.**
 1. Conditions and environments outside of the given specifications, or use outdoors or in a place exposed to direct sunlight.
 2. Use for nuclear power, railways, aviation, space equipment, ships, vehicles, military application, equipment affecting human life, body, and property, fuel equipment, entertainment equipment, emergency shut-off circuits, press clutches, brake circuits, safety equipment, etc., and use for applications that do not conform to standard specifications such as catalogs and operation manuals.
 3. Use for interlock circuits, except for use with double interlock such as installing a mechanical protection function in case of failure. Please periodically inspect the product to confirm that the product is operating properly.



Safety Instructions

Caution

We develop, design, and manufacture our products to be used for automatic control equipment, and provide them for peaceful use in manufacturing industries.

Use in non-manufacturing industries is not covered.

Products we manufacture and sell cannot be used for the purpose of transactions or certification specified in the Measurement Act.

The new Measurement Act prohibits use of any unit other than SI units in Japan.

Limited warranty and Disclaimer/Compliance Requirements

The product used is subject to the following “Limited warranty and Disclaimer” and “Compliance Requirements”.

Read and accept them before using the product.

Limited warranty and Disclaimer

1. The warranty period of the product is 1 year in service or 1.5 years after the product is delivered, whichever is first.*2)

Also, the product may have specified durability, running distance or replacement parts. Please consult your nearest sales branch.

2. For any failure or damage reported within the warranty period which is clearly our responsibility, a replacement product or necessary parts will be provided.

This limited warranty applies only to our product independently, and not to any other damage incurred due to the failure of the product.

3. Prior to using SMC products, please read and understand the warranty terms and disclaimers noted in the specified catalog for the particular products.

***2) Vacuum pads are excluded from this 1 year warranty.**

A vacuum pad is a consumable part, so it is warranted for a year after it is delivered.

Also, even within the warranty period, the wear of a product due to the use of the vacuum pad or failure due to the deterioration of rubber material are not covered by the limited warranty

Compliance Requirements

1. The use of SMC products with production equipment for the manufacture of weapons of mass destruction (WMD) or any other weapon is strictly prohibited.

2. The exports of SMC products or technology from one country to another are governed by the relevant security laws and regulations of the countries involved in the transaction. Prior to the shipment of a SMC product to another country, assure that all local rules governing that export are known and followed.

Operator

- ◆ This operation manual has been written for those who have knowledge of machinery and apparatus using pneumatic equipment, and have full knowledge of assembly, operation and maintenance of such equipment.
- ◆ Please read this operation manual carefully and understand it before assembling, operating or providing maintenance to the product.

■ Precautions

Danger

- After maintenance is complete, perform appropriate functional inspections.
Stop operation if the equipment does not function properly.
Safety cannot be assured in the case of unexpected malfunction.

Warning

- Do not operate the product outside of the specifications.
Do not use for flammable or harmful fluids.
Fire, malfunction, or damage to the product can result.
Verify the specifications before use.
- Do not operate in an atmosphere containing flammable or explosive gases.
Fire or an explosion can result.
This product is not designed to be explosion proof.
- If using the product in an interlocking circuit:
 - Provide a double interlocking system, for example a mechanical system.
 - Check the product regularly for proper operation.Otherwise malfunction can result, causing an accident.
- The following instructions must be followed during maintenance:
 - Turn off the power supply.Otherwise an injury can result.

Caution

- Provide grounding to assure the noise resistance of the product using fieldbus.
Individual grounding should be provided close to the product with a short cable.

■NOTE

- Follow the instructions given below when designing, selecting and handling the product.
 - The instructions on design and selection (installation, wiring, environment, adjustment, operation, maintenance, etc.) described below must also be followed.

*Product specifications

- Use the specified voltage.
Otherwise failure or malfunction can result.
- Reserve a space for maintenance.
Allow sufficient space for maintenance when designing the system.
- Do not remove any nameplates or labels.
This can lead to incorrect maintenance, or misreading of the operation manual, which could cause damage or malfunction to the product.
It may also result in non-conformity to safety standards.

●Product handling

*Installation

- Do not drop, hit or apply excessive shock to the product.
Otherwise damage to the product can result, causing malfunction.
- Tighten to the specified tightening torque.
If the tightening torque is exceeded the mounting screws may be broken.
- Never mount a product in a location that will be used as a foothold.
The product may be damaged if excessive force is applied by stepping or climbing onto it.

*Wiring

- Avoid repeatedly bending or stretching the cables, or placing heavy load on them.
Repetitive bending stress or tensile stress can cause breakage of the cable.
- Wire correctly.
Incorrect wiring can break the module.
- Do not perform wiring while the power is on.
Otherwise damage to the product can result, causing malfunction.
- Do not route wires and cables together with power or high voltage cables.
Otherwise the product can malfunction due to interference of noise and surge voltage from power and high voltage cables to the signal line.
Route the wires (piping) of the product separately from power or high voltage cables.
- Confirm proper insulation of wiring.
Poor insulation (interference from another circuit, poor insulation between terminals, etc.) can lead to excess voltage or current being applied to the module, causing damage.
- Take appropriate measures against noise, such as using a noise filter, when the product is incorporated into equipment.
Otherwise noise can cause malfunction.

*Environment

- Do not use in a place where the product could be splashed by oil or chemicals.
If the product is to be used in an environment containing oils or chemicals such as coolant or cleaning solvent, even for a short time, it may be adversely affected (damage, malfunction etc.).
- Do not use the product in an environment where corrosive gases or fluids could be splashed.
Otherwise damage to the product and malfunction can result.
- Do not use in an area where surges are generated.
If there is equipment which generates a large amount of surge (solenoid type lifter, high frequency induction furnace, motor, etc.) close to the fieldbus system, this may cause deterioration or breakage of the internal circuit of the fieldbus system. Avoid sources of surge generation and crossed lines.
- The product is CE marked, but not immune to lightning strikes. Take measures against lightning strikes in the system.
- Prevent foreign matter such as remnant of wires from entering the fieldbus system to avoid failure and malfunction.
- Mount the product in a place that is not exposed to excessive vibration or impact.
Otherwise failure or malfunction can result.
- Do not use the product in an environment that is exposed to temperature cycle.
Heat cycles other than ordinary changes in temperature can adversely affect the inside of the product.
- Do not expose the product to direct sunlight.
If using in a location directly exposed to sunlight, shade the product from the sunlight.
Otherwise failure or malfunction can result.
- Keep within the specified ambient temperature range.
Otherwise malfunction can result.
- Do not operate close to a heat source, or in a location exposed to radiant heat.
Otherwise malfunction can result.

*Adjustment and Operation

- Set the switches by using a sharp-pointed screwdriver etc.
Caution: Ensure the tool does not damage the switches during this process.
- Perform settings suitable for the operating conditions.
Caution: Incorrect settings can cause operation failure and unexpected actuator behavior
- Please refer to the PLC manufacturer's manual etc. for details of programming and addresses.
For the PLC protocol and programming refer to the relevant manufacturer's documentation.



***Maintenance**

- Perform regular maintenance and inspections.

There is a risk of unexpected malfunction.

- After maintenance is complete, perform appropriate functional inspections.

Stop operation if the equipment does not function properly.

Otherwise safety is not assured due to an unexpected malfunction or incorrect operation.

- Do not use solvents such as benzene, thinner etc. to clean the module.

They could damage the surface of the body and erase the markings on the body.

Use a soft cloth to remove stains.

For heavy stains, use a cloth soaked with diluted neutral detergent and fully squeezed, then wipe up the stains again with a dry cloth.

Fieldbus System/ Industrial IoT Cybersecurity

In recent years, factories have introduced industrial IoT, building up complex networks of production machines. These systems may be subject to a new threat, cyberattack. To protect the industrial IoT from cyberattacks, it is important to take multiple measures (multi-layer protection) for IoT devices, networks and clouds.

For this purpose, SMC recommends that the following measures are always taken into consideration. For further details of the following measures, please see security information published by your country's security agencies.

1. Do not connect the devices via a public network.

- If you unavoidably need to access the device or cloud via a public network, ensure to use a secure, private network such as VPN.
- Do not connect an office IT network and factory IoT network.

2. Build a firewall to prevent a threat from entering the device and system.

- Set up a router or firewall at network boundaries to allow minimum required communications.
- Disconnect from the network or turn off the device, if no continuous connection is required.

3. Physically block access to unused communication ports or disable them.

- Inspect regularly each port if any unnecessary device is connected to the network system.
- Operate necessary services (SSH, FTP, SFTP, etc.) only.
- Set a transmission range of the device using a wireless LAN or other radio system to the minimum required and use only devices approved according to the radio act in the country concerned.
- Install a device generating radio waves in such place as there is no interference from indoor or outdoor.

4. Set up a secure communication method such as data encryption.

- Encrypt data in every environment, including IoT networks, secure gate-way connections, for secure communications.

5. Grant access permissions by user accounts and limit the number of users.

- Regularly review accounts and delete all unused accounts or permissions.
- Establish an account lockout system to block an access to the account for a certain period if log-in fails more than the given threshold.

6. Protect passwords.

- Change the default password when you first use the device or system.
- Choose a long password (minimum 8 characters) using a mix of different letters and characters to make the password more secure and harder to hack.

7. Use the latest security software.

- Install antivirus software on all computers to detect and remove viruses.
- Keep the antivirus software up to date.

8. Use the latest version of the device and system software.

- Apply patches to keep the OS and applications up to date.

9. Monitor and detect abnormalities in the network.

- Keep monitoring the network for any abnormalities to take a prompt measure and issue an alert if any abnormality is detected.

Install an intrusion detection system (IDS) and intrusion prevention system (IPS).

10. Delete data from devices when disposed of.

- Before disposing of any IoT devices, delete stored data or physically destruct media to prevent any misuse of the data.

1. For your safety

1.1. Purpose of this manual

This user manual provides information about how the module works, its operating and connection elements, and its parameter settings.

1.2. Validity of the user manual

This user manual is valid for the EX600-FVC# module in the version indicated on the inner cover page, as well as for the same or later versions if replaced with the devices of the same type.

1.3. Residual Risks

WARNING

The residual risks are identified in this section, which result from the hazard analysis. Observe the listed safety warnings here and the notes throughout the whole manual to reduce health hazards and to avoid dangerous situations. Please be sure to follow the instructions in this manual to reduce residual risks and use this product within the safety related specifications.

Machine manufacturers are responsible for all risk evaluations and all associated residual risks. Below are residual risks associated with the Safety Input and Safety Output functions. SMC is not liable for any damages or injuries caused by these risks.

1.3.1. Risk of injury

Depending on the application, inappropriate use of the module may result in serious injury. Use the module only in an environment that is within the general specifications of the module. SMC is not responsible for conformity with any standards, codes, or regulations that apply to the combination of products in your application or use of the product. Take all necessary steps to determine the suitability of the product for the systems, machine, and equipment with which it is used. Know and observe all prohibitions of use applicable to this product. Never use the products for an application that involves serious risk to life or property without making sure of the following:

- Observe all the safety notes provided in this manual.
- The system as a whole is designed to address the risks.
- The module is properly rated and installed for the intended use within the overall equipment or system.
- Allowing access to the danger zone without activating the safety function. The danger zone must be inaccessible if the safety function is not activated.
- In the safety circuit, only use components that meet the required safety standards.
- Safety is not assured until all safety related components of the system are completely installed and the system has been validated by a competent person.
- Perform all risk assessments to the machine or whole system before initial use and after any maintenance work

1.3.2. Loss of safety function

Incorrect installation and/or sequential faults can result in the loss of the safety function as well as hazardous shock currents. In the event of a device error, the module should be disconnected completely from the power supply and replaced so as to prevent sequential faults. Please be sure to plan the following items when installing.

- Observe the notes on electrical safety in this manual.
- Plan the modules used and their installation in the system according to the specific requirements using the checklist in this manual.
- Recheck plants and systems retrofitted with CIP safety.

1.3.3. Operating time in the error state

If an error state is entered on the modules, this error must be assessed, acknowledged or removed by the user within 72 hours. This action ensures the safe operating state of the module. Exceeding this time limit is not recommended and may adversely affect the future safety performance of the module.

In the error operating state, internal module tests are no longer run and it is possible that the safe state may be exited due to an accumulation of errors.

1.4. General safety notes

1.4.1. Qualified personnel

Within the context of this user manual, qualified personnel are persons who, because of their education, experience and instruction, and their knowledge of relevant standards, regulations, accident prevention, and service conditions, have been authorized to carry out any required operations, and who are able to recognize and avoid any possible dangers.

Furthermore, knowledge of the following topics and module is required:

- Components used
- EX600-FVC# product range
- Operation of the software tools
- Safety regulations in the field of application

In the context of the use of the CIP safety system, the following operations must only be carried out by qualified personnel:

- Planning
- Configuration, parameterization, programming
- Installation, commissioning, servicing
- Maintenance, decommissioning

1.4.2. Documentation

Observe all information in this user manual and the accompanying documents: see [6.1 Checklists](#). Always use the latest documentation for this product. Changes or additions to documentation can be found on the Internet (see: <https://www.smcworld.com/>).

1.4.3. Safety of personal and equipment

The safety of personnel and equipment can only be assured if the module is used correctly: see [1.7.1 Intended use](#).

1.4.4. Error detection

Depending on the wiring and the parameterization, the module detects errors within the safety equipment.

1.4.5. Maintenance and Repairs

To prevent accumulation of malfunctions, perform malfunction checks at regular intervals (otherwise known as the diagnostic test interval) based on the risk assessments of the machine or the system is recommended.

With the exception of these periodic diagnostic tests, there is no other specific maintenance agenda for the EX600-FV## while it is in service. The module does not contain any components requiring maintenance.

1.4.6. Do not carry out any repairs or modifications

It is prohibited for the user to carry out repair work or make modifications to the module. The housing must not be opened. The module is protected against tampering by means of security labels. The security label is damaged in the event of unauthorized repairs or opening of the housing. In this case, the correct operation of the safety product can no longer be ensured, and any warranty is invalidated.

When an error occurs, remove the cause of the failure based on the [6.2 Troubleshooting](#) in this manual and if in the event of an unrecoverable error, send the product to SMC or contact SMC immediately.

1.4.7. Product Replacement

Any replacements must be of the exact same type and model. Please see [4. Commissioning](#) for re-commissioning, which is essential if the module is replaced. The product must be replaced before the Mission time (T_M) ends. See [5.1 Safety specifications](#). The safety system must be reassessed if no exact replacement can be used.

1.4.8. Product Disposal

This product shall not be disposed of as municipal waste. Check your local regulations and guidelines to dispose of this product correctly, in order to reduce the impact on human health and the environment.

1.4.9. Mismatching and polarity reversal of connections

Take care to avoid the mismatching, polarity reversal or tampering of connections.

1.5. Electrical safety



Loss of safety function/hazardous shock currents

Incorrect installation can result in the loss of the safety function as well as hazardous shock currents.

- Observe the notes on electrical safety.
- Plan the modules used and their installation in the system according to the specific requirements.
- Recheck plants and systems retrofitted with CIP safety.

1.5.1. Direct/indirect contact

Protection against direct and indirect contact according to VDE 0100 Part 410 / EN 61010-2-201 must be ensured for all components connected to the system. In the event of an error, parasitic voltages must not occur (single-fault tolerance).

Measures required:

- Using power supply units with safe isolation (PELV/SELV).
- Decoupling circuits, which are not PELV/SELV systems, using optocouplers, relays, and other components which meet the requirements of safe isolation.

1.5.2. Power supply units for 24V supply

Only use power supply units with safe isolation and PELV/ SELV according to EN 61140. These power supply units prevent short circuits between the primary and secondary side. Make sure that the output voltage of the power supply does not exceed product specification range even in the event of an error. Note if an SELV supply is used then the supply 0 V should be connected to protective bonding circuit in accordance with the basic safety principles according to EN ISO 13849.

This product also has an over-power protection. This function allows the product to shift a safe state using hardware functions in the event of an external SELV/PELV power supply failure or internal HW failure in the product. To ensure that this hardware function works normally, please use a power supply with a current capacity of 20A or more.

1.5.3. Insulation rating

When selecting the equipment, please take into consideration the pollution degree and surge voltages which may occur during operation. The EX600-FVC# is designed for use with connecting cables that are less than 20 m long and do not go outside of a building (see Section [5.2 General specifications](#) for permitted cable lengths). If these requirements are not met, then external measures must be taken to protect the module accordingly.

1.6. Safety of the machine or system

The machine/system manufacturer and the operator are responsible for the safety of the machine or system and the application in which the machine or system is used.

1.6.1. Draw up and implement a safety concept

In order to use the module, a safety concept is required for your machine or system. This includes a hazard and risk analysis as well as a test report (checklist) for validating the safety function: see [1.7 Directive and standards](#) and see [6.1 Checklists](#).

The target safety integrity level (SIL according to IEC 61508, SILCL according to EN 62061 or performance level and category according to EN ISO 13849-1) is ascertained on the basis of the risk analysis. The safety integrity level ascertained determines how to connect and parameterize the module within the safety function.

1.6.2. Validate hardware and parameterization

Carry out a validation every time you make a safety-related modification to your overall system.

Use your test report to ensure that:

- The safe modules are connected to the correct sensors and actuators.
- The safe input have been parameterized correctly.
- The variables have been linked to the safe sensors and actuators correctly (single-channel or two-channel).

See [4 Commissioning](#) for detail of the setting the module.

1.7. Directive and standards

The standards to which the module conforms are listed in the certificate issued by the approval body and in the EU and UK declarations of conformity.

Refer to the latest Declaration of Conformity on our [website](https://www.smcworld.com) (<https://www.smcworld.com>).

1.7.1. Intended use

The EX600-FVC# module is designed exclusively for use in a CIP safety system and fulfils the EtherNet/IP guidelines as defined by ODVA. It can only perform its tasks in the system if it is used according to the specifications in this document.

Only use the module according to the defined technical data and ambient conditions: see [5.2 General specifications](#). SMC Co. accepts no claims for liability if the equipment is used in any other way or if modifications are made to the device, even in the context of mounting and installing.

The module is designed for connecting single-channel or two-channel sensors, which can be used in association with safety technology.

Examples of use for the module:

- Single or two-channel emergency stop or safety door equipment
- Applications with enable button
- Applications with two-hand control devices
- Applications with mode selector switches
- As secondary switchgear for safety-related photoelectric barriers
- Safety circuits according to EN 60204, Part 1

For the features of the module; see [2.1 Features](#)

1.8. Abbreviations used

Table 1.8-1 Abbreviations for safety requirements

Abbreviation	Meaning	Standard	Example
SIL	Safety integrity level	IEC 61508	SIL 2, SIL 3
SILCL	SIL claim limit	EN 62061	SIL CL 3
Cat.	Category	EN ISO 13849-1	Cat. 2, Cat. 3
PL	Performance level	EN ISO 13849-1	PL d, PL e

Abbreviation	Meaning
PELV	Protective extra-low voltage according to EN 61140
SELV	Separated extra-low voltage according to EN 61140

2. Product outline

2.1. Features

2.1.1. Features of the Safety IO module

The EX600-FVC# module implements CIP safety over EtherNet/IP for SMC pneumatic valves. The module can be used to implement a safety function for the directly connected valves and has the following properties:

- IP65/IP67
- Up to 16 safety digital inputs and up to 3 safety digital outputs.
- Up to 128 solenoid valves outputs.
- Up to 4 IITV series can be controlled by this module .
- Safety parameters can be set only with the PLC configuration tool (e.g. Studio 5000, SYSMAC studio)
- Integrated diagnostic and protection function
- Galvanically isolated power supplies
- Designed for use in safety systems up to SIL 3 according to EN 61508 and Performance level (PL) e according to EN ISO 13849
- Corresponding solenoid valve manifolds
 - JSY series
 - SY series
 - VQC series

2.2. Safety function overview

2.2.1. Safety inputs

2.2.1.1. Safe state

The safe state of the module is when the input is set to "0" and the process data of the input: "0" is transmitted to the upper safety controller (e.g., PLC). The safety input is shifted to the safe state the related input or all inputs depending on a fault.



This safety function is only guaranteed to work if the product is used in accordance with the product specifications described in this manual.

2.2.1.2. Safe digital inputs

The module has safe digital inputs, which can be used as follows:

- For two-channel assignment: 8 two-channel inputs
- For single-channel assignment: 16 single-channel inputs

Or a combination of two and single channel inputs.

Technical data for the safe inputs: see [4.5 Safety inputs](#). The supply voltage for the inputs can be provided externally or via the clock outputs. Refer to relevant standards and apply Fault exclusion where necessary.

2.2.1.3. Clock pulse UT1-UT5

The module has five independent clock outputs. These clock outputs provide the supply voltage for the safe inputs on the Safety IO module or external input equipment (e.g., Emergency button, Light curtain). Each clock outputs provide a pulse pattern to detect cross circuits in the external wiring of the inputs if Cross circuit detection has been activated for at least one input pair.

The clock pulse is disabled while the module is not parameterized. To enable clock pulses, the parameter must be set. See [4.4.1 Safe parameterization](#) for details. Specification of clock pulse: see [5.1 Safety specifications](#).

WARNING

- When connecting sensors with a capacitive component (e.g., light curtain) to the Safety IO module, inrush currents may occur on the connected power supply (UT1-5) and it is causing the power supply in the relevant area not to function properly. When connecting sensors with a capacitive component to the Safety IO module, please check the current consumption/start-up current of the sensor device used and consider supplying power to the device with a separate power supply if necessary.
- When supplying a separate power supply to sensors, please make sure that Common (0V) is at the same potential as the Safety IO module. If not on the same potential, the safety functions of the Safety IO module may not work properly.

2.2.1.4. Parameterization

The safe digital inputs of the module can be parameterized in pairs of connectors. This means that the inputs can be adapted to various operating conditions and different safety integrity levels can be implemented (SIL, SILCL, Cat., PL). See [6.3 Safety integrity level with the system](#).

The module's ability to detect faults depends on the parameterization. Adapt the module parameterization to the relevant sensor/controlling device: see [4.4.1 Safe parameterization](#).

Attention

Safety input functions are activated after parameter setting has been completed. For the process to set parameters, see [4.4.1 Safe parameterization](#).

2.2.1.5. Diagnostics

Diagnostics on safety input function can be shown on the process data. See [4.8.1 Safety related diagnostics](#) for detail.

2.2.2. Safety outputs

2.2.2.1. Safe state

The safe state of the module is the safety output (Z1-3) is in the "0" state.

2.2.2.2. Safe digital outputs

The module has 3 digital outputs which can be used for each of the valve zones: Z1, Z2 & Z3. Users must take all necessary precautions to avoid any external short circuits to the outputs. Refer to relevant standards and apply Fault exclusion where necessary.

WARNING

Connection of the 0V to another 0V supply will bridge the safe output switch and cause a detected error. Connection of any output to another voltage supply will bridge the safe output switch and cause a undetected errors.

2.2.2.3. Clock pulse

The module has 3 independent high side clock outputs and 1 low side clock output. These clock outputs provide the supply voltage for the safe output on the Safety IO module or external output equipment (e.g., Safety valve, safety relay). Each clock output provides a pulse pattern to detect internal faults (Stuck at).

The clock pulse is disabled while the module is not parameterized. To enable clock pulses, the parameter must be set: See [4.4.1 Safe parameterization](#) and relevant safety outputs turned ON. Specification of clock pulse: see [5.1 Safety specifications](#).

Caution

Safety outputs are activated after parameter setting has been completed. Safety outputs should not be used to provide power to a device or sub-system where the resistive and capacitive load could vary during operation.

2.2.2.4. Diagnostics

Diagnostics on safety output function can be shown in the process data. See [4.8.1 Safety related diagnostics](#) for detail.

2.3. Structure

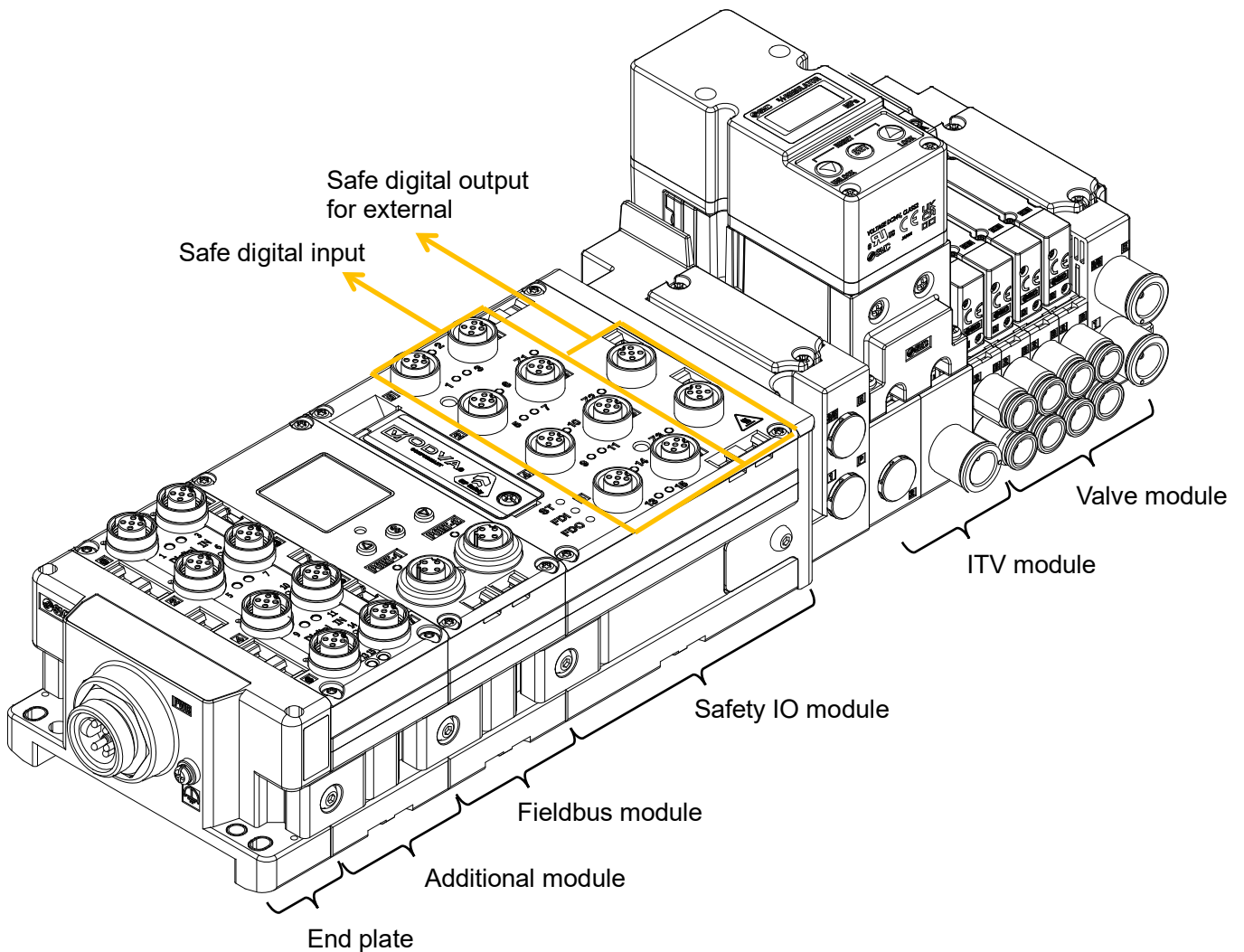

Fig. 2.3-1 Product structure: EX600-FVC#

Table 2.3-1 Product overview on the valve manifold

Component	Function
Safety IO module	Control safe input, safe output, valve modules and ITV modules. (ITV module can only be controlled by EX600-FVC2 and EX600-FVC4)
Fieldbus module	Communicate with upper controller via fieldbus (e.g. EtherNet/IP).
Additional module	Digital input/output, analog input/output, IO-link module. See our website for details of the products.
ITV module	ITV module can only be controlled by EX600-FVC2 and EX600-FVC4.
Valve module	Operate pneumatic devices.
End plate	Supply power to the valve manifold.

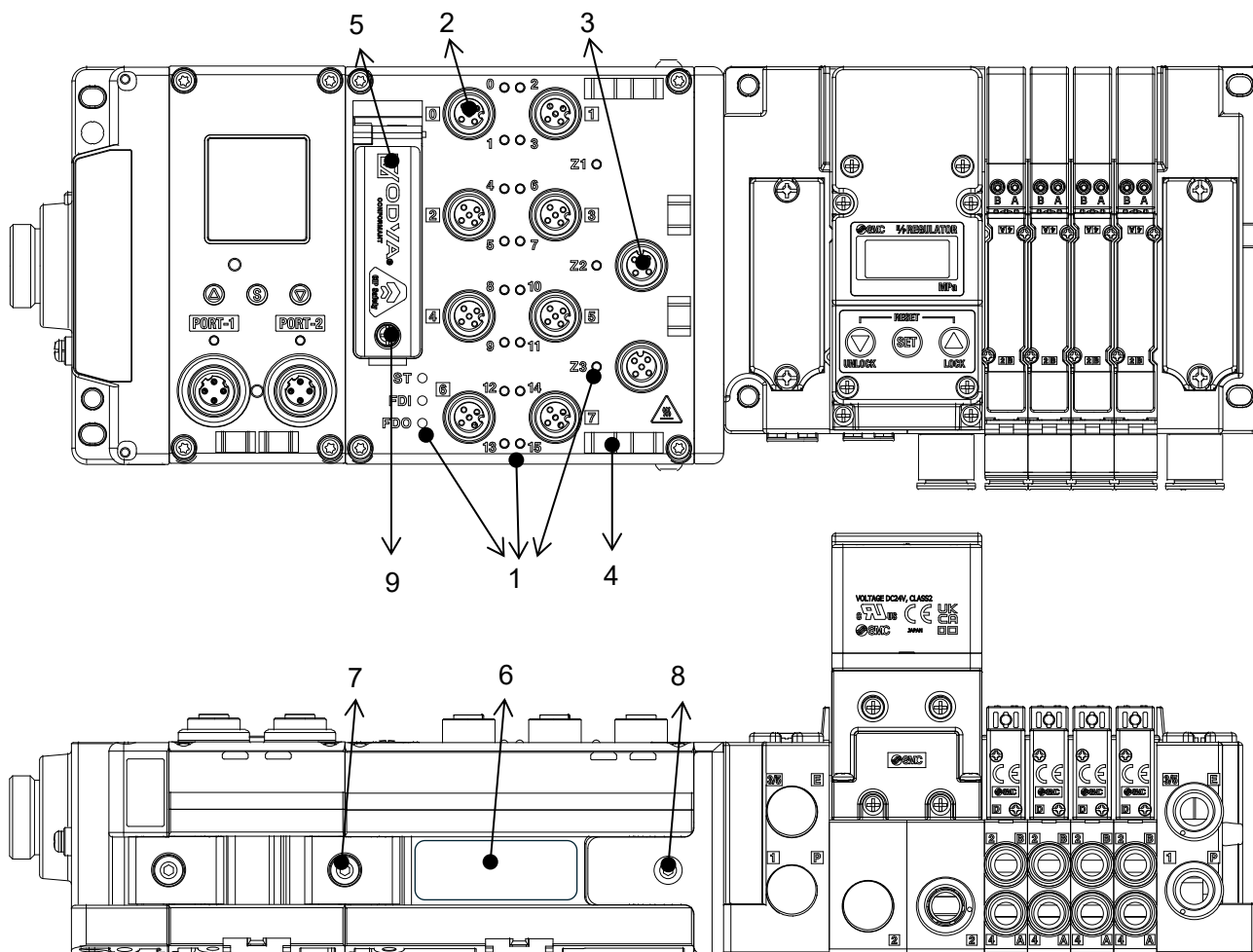

Fig. 2.3-2 Name of the components

No.	Name	Function
1	Status LED	LED for displaying the module status.
2	Safety input connector	Connectors for safety input. For reference in this manual, this component is referred to as "CN#". Note that "CN#" is not marked on the actual product. The "#" indicates the number engraved within the square marking located next to the connector.
3	Safety output connector	Connectors for safety output. The number of these connectors varies depending on the selected model. For details, refer to Table 2.4-1 . The safety output corresponding to the Z# LED located to the left of the connector is output through this connector.
4	Marker groove	Groove for an identification marker.
5	Display window	-
6	Product label	See 5.3 Production label
7	Joint bracket	Bracket for joining the next module.
8	Screw for attaching the valve module	Screw hole for attaching the valve plate
9	Screw for display window	Screw for display window. This screw is not used in the EX600-FVC#. If you use this screw by mistake, the module may not be satisfying the protection rating (e.g. IP65/IP67). The tightening torque is 0.7 - 0.8 Nm.

2.4. Product type

Table 2.4-1 Product type and product number

No.	Product number	Safety input	Safety output		Valve outputs	ITV module
			External power supply M12 connector (top of module)	Internal valve power supply		
1	EX600-FVC1	16	2 (Z2/Z3)	1 (Z1)	Up to 32	-
2	EX600-FVC2		2 (Z2/Z3)	1 (Z1)	Up to 128	Up to 4
3	EX600-FVC3		-	3 (Z1/Z2/Z3)	Up to 128	-
4	EX600-FVC4		1 (Z3)	2 (Z1/Z2)	Up to 128	Up to 4

2.5. LED indicators

Caution

LEDs are not a safety function and it cannot be guaranteed to provide accurate information. They should only be used for general diagnostics during commissioning or troubleshooting. Do not attempt to use LEDs as operational indicators.

Table 2.5-1 ST LED indication





LED	Status	Description
	OFF	Power supply is not present
	Green ON	Non-safety function is running
	Green/Red Blinking (0.5Hz)	Detects low priority non-safety function fault. Request removing the cause of fault.
	Red ON	Detects high priority function fault. Restart power supply to turn module back on again.

Table 2.5-2 FDI LED indication



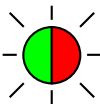

LED	Status	Description
	OFF	Power supply is not present
	Green ON	Safety input function is running
	Green Blinking (0.5Hz)	Request to set the safety parameter in the module.
	Green/Red Blinking (0.5Hz)	Detects setting parameter is invalid. Request to set parameters again.
	Red Blinking (0.5Hz)	Detect low priority fault in the safety input function. Request error reset using "Error reset bit" after removing the cause of the faults.
	Red Blinking (2.0Hz)	Detect high priority fault in the safety input function. Restart power supply to turn module back on again. OR Reset where supported by the fieldbus protocol.
	Red ON	Detect high priority fault in the safety input function. Restart power supply to turn module back on again.

Table 2.5-3 FDO LED indication



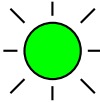
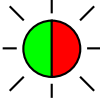
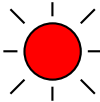
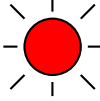

LED	Status	Description
	OFF	Power supply is not present
	Green ON	Safety output function is running
	Green Blinking (0.5Hz)	Request to set the safety parameter in the module.
	Green/Red Blinking (0.5Hz)	Detects setting parameter is invalid. Request to set parameters again.
	Red Blinking (0.5Hz)	Detect low priority fault in the safety output function. Request error reset using "Error reset bit" after removing the cause of the faults.
	Red Blinking (2.0Hz)	Detect high priority fault in the safety output function. Restart power supply to turn module back on again. OR Reset by fieldbus protocol.
	Red ON	Detect high priority fault in the safety output function. Restart power supply to the module back on again.

Table 2.5-4 0-15 LED indication





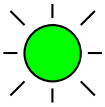
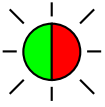
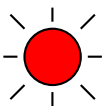
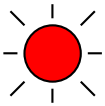

LED	Status	Description
	OFF	Power supply is not present, or related safety input is OFF
	Green ON	Related safety input is ON
	Red ON	Detect fault on the related input The error should be reset according to the blinking status of the FDI LED.

Table 2.5-5 Z1-3 LED indication

LED	Status	Description
	OFF	Power supply is not present, or related safety output is OFF
	Green ON	Related safety output is ON
	Red ON	Detect fault on related output The error should be reset according to the blinking status of the FDO LED.

3. Installation

3.1. Composing the module as a manifold

1. Connect the safety IO module to the next modules. Tightening torque is 1.5 to 1.6 Nm for hexagonal socket screws (width across flats 2.5 mm). See the Fieldbus module instruction manual for information on how to install the valve manifold.

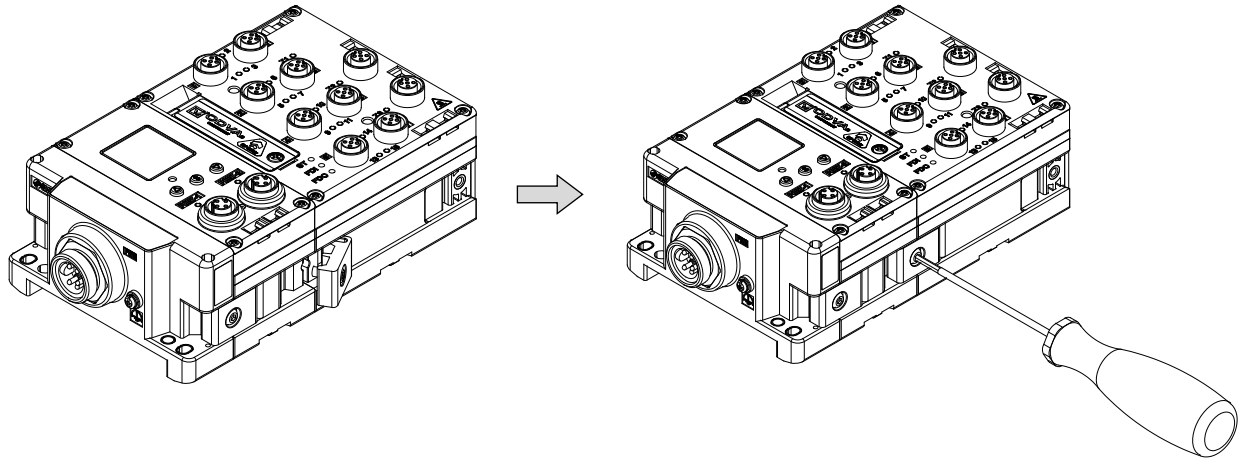

Fig. 3.1-1

2. Connect the valve plate (EX600-ZMV#) to the valve module using the attached Phillips screws (M3 x 8 mm). Tightening torque is 0.6 to 0.7 Nm

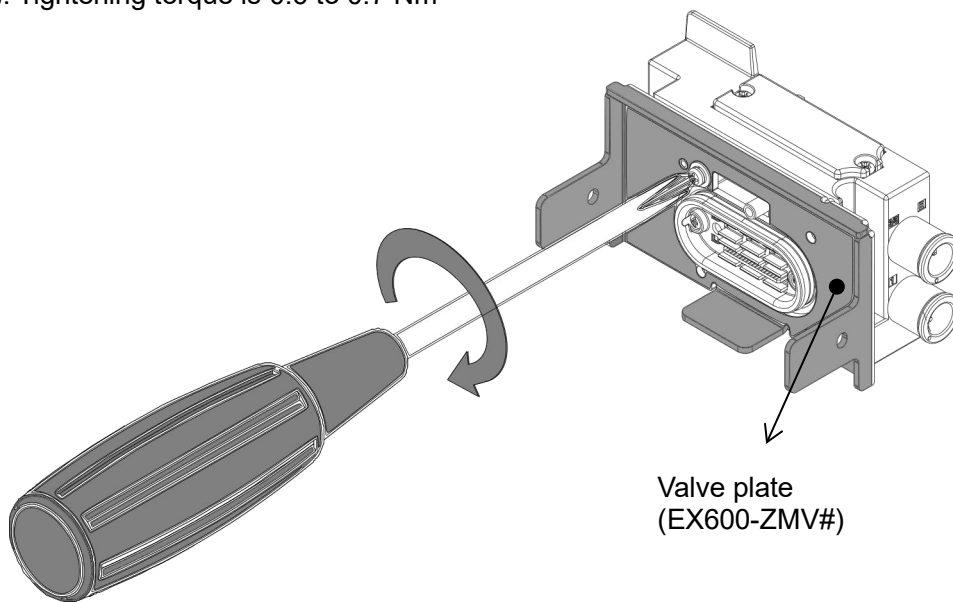

Fig. 3.1-2

3. Connect the safety IO module and valve module using the attached hexagonal socket screws (width across flats 2.5 mm). Tightening torque is 0.7 to 0.8 Nm

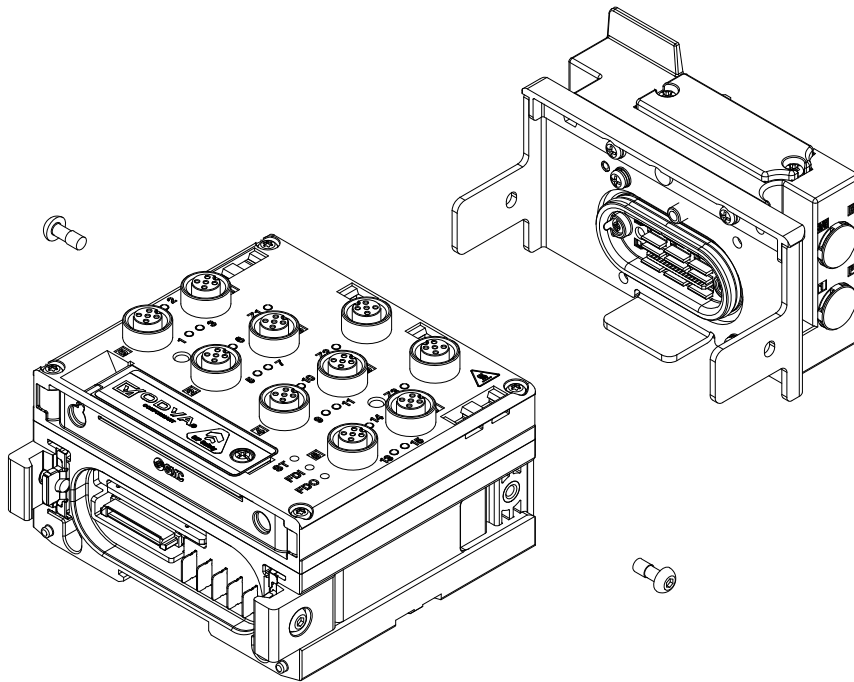

Fig. 3.1-3

! WARNING

- To prevent damage, all power for the modules must be turned off (i.e. de-energized) before the modules are installed or removed.
- Screws should be tightened to the specified torque. Insufficient tightening may lead to equipment malfunction, injury, or equipment damage.

3.2. Dimensions

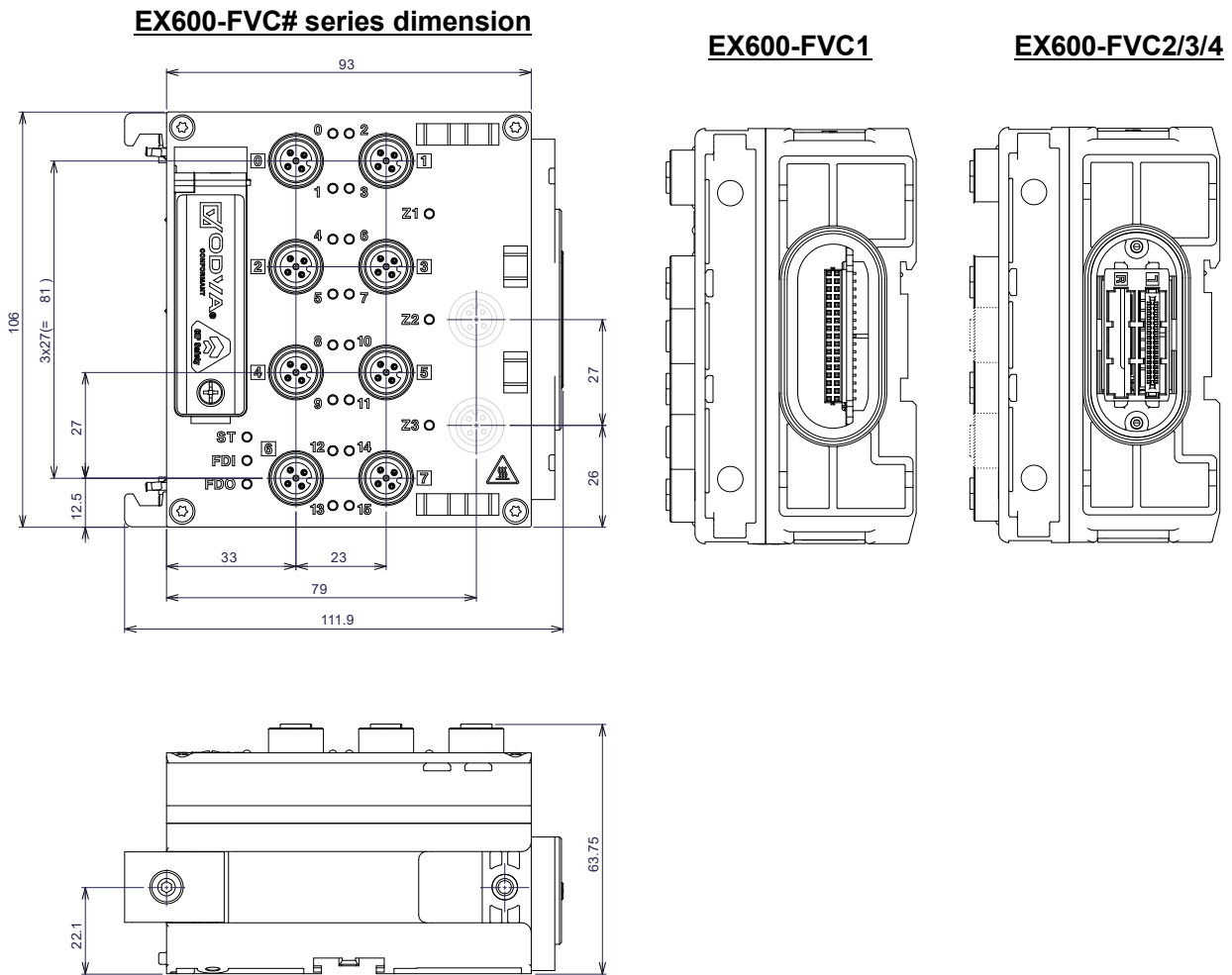

Fig. 3.2-1 Dimension: EX600-FVC# series

Attention

- The number of M12 connectors (Z2, Z3) for supplying the safety output to external devices varies depending on the selected model. For details, please refer to [Table 2.4-1](#) and [5.4 Block diagrams](#).

3.3. Connectors

Table 3.3-1 Safety input interface

Pin No.	Allocation								View of M12 connector (Module side: female, A-code)
	CN0	CN1	CN2	CN3	CN4	CN5	CN6	CN7	
1	UT1	UT1	UT2	UT2	UT3	UT3	UT4	UT4	
2	IN1	IN3	IN5	IN7	IN9	IN11	IN13	IN15	
3	0V(US1)								
4	IN0	IN2	IN4	IN6	IN8	IN10	IN12	IN14	
5	UT5								
Outer shell	FE (functional earth)								

Table 3.3-2 Safety output interface

Pin No.	Allocation		View of M12 connector (Module side: female, A-code)
	Z2	Z3	
1	N.C.	N.C.	
2	N.C.	N.C.	
3	Safety output (0V)	Safety output (0V)	
4	Safety output2 (24V)	Safety output3 (24V)	
5	FE (functional earth)		

WARNING

- For a protection rating of IP65/IP67 to be ensured, all covering caps must be screwed down correctly after wiring and setting have been performed.
- Users must take all necessary precautions to avoid any external short circuits on the cable. Refer to relevant standards and apply Fault exclusion where necessary.
- For an overview of safety input and safety output, see [2.2.1 Safety inputs](#), [2.2.2 Safety outputs](#). Failure to comply with the information in the relevant chapters may cause the product to operate in unintended operation.
- This connector may become hot when energized. Do not touch it while it is energized.

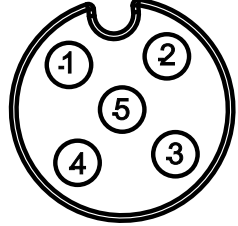
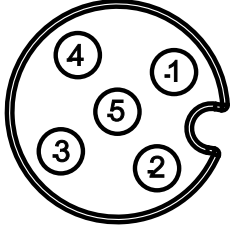
Attention

- The number of M12 connectors (Z2, Z3) for supplying the safety output to external devices varies depending on the selected model. For details, please refer to [Table 2.4-1](#) and [5.4 Block diagrams](#).

4. Commissioning

4.1. Configuration

Configure the module according to the procedure in [Fig. 4.1-1](#). When a diagnosis is detected, return to the relevant process. The user must always check that the valve manifold is operating as intended.

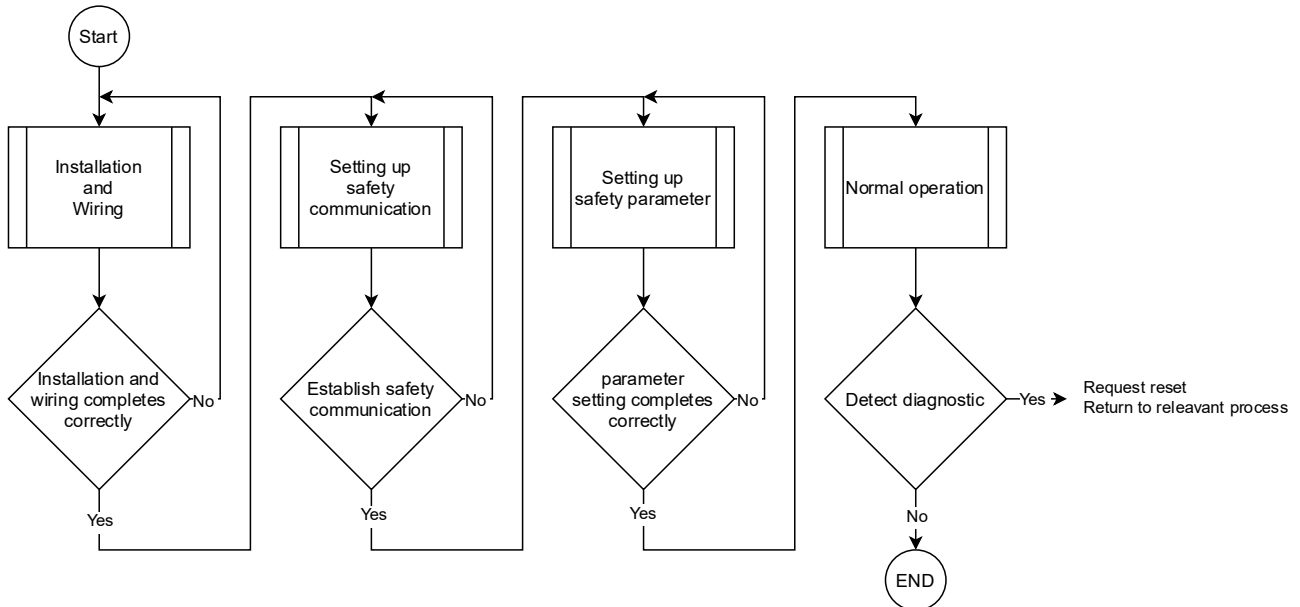

Fig. 4.1-1 Flow chart

⚠ WARNING

- With the exception of periodic diagnostic tests, there is no other specific maintenance agenda for the EX600-FV## while it is in service. The module does not contain any components requiring maintenance. Repairs are prohibited, see [1.4.6 Do not carry out any repairs or modifications](#).
- The safety function (safety inputs and safety outputs) of the Safety IO module is only activated if all processes are completed successfully.
- Please use the [6.1 Checklists](#) for the planning, assembly and electrical installation, commissioning, parameterization, and validation.
- Access to the safety function of EX600-FV## is possible only via upper safety PLC system. Access to configuration tool of upper safety PLC system is limited to authorized personnel only. See [1.4.1 Qualified personnel](#) for detail.

Attention

- See the Fieldbus module instruction manual for details on the configuration other than safety related function.
- Please check [Fig. 4.1-1](#) and [6.2 Troubleshooting](#) when performing maintenance as necessary.

4.2. Safety communication

4.2.1. Establishing safety communication

Refer to the instruction manual of the respective safety controller for the procedure to establish safety communication (e.g. CIP safety). See [Table 4.2-1](#) for parameters required to establish safety communication. For the IO size of the safety IO module when safety communication is established, [see Table 4.2-2](#).

Table 4.2-1 Connection parameters

Items	Specification
Vendor	7
Product type	12
Product code	271
Product revision	1.001
Data format	SINT
Input size and assembly Instance	See Table 4.2-2
Output size and assembly Instance	See Table 4.2-2
CIP safety connection	Type2
SCCRC	ID: 59757269
SCTS	Date: 2024/06/12 Time: 7:48:46, 579ms (UTC)

Table 4.2-2 IO size

Items	Input		Output		Configuration	
	Assembly Instance	Size [byte]	Assembly Instance	Size [byte]	Assembly Instance	Size [byte]
Safety input	800	10	1024	-	805	-
Safety output	1024	-	850	6		
Standard	100	*	150	*	105	*

*: Depends on valve manifold total IO size.

WARNING

- SCCRC and SCTS must be set values listed in [Table 4.2-1](#). If these parameter uses different value other than table above, the module may behave in an unintended operation mode. If you set to configure safety connections with other than value in [Table 4.2-1](#), you are responsible for ensuring that originators and targets have the correct configurations.
- The user should assign the safety network numbers (SNN) for each safety network or safety subnet that are unique system-wide.

Attention

- SCCRC and SCTS and safety network numbers can be set after the connection with the upper controller is complete. If the connection has not been established due to a mismatch in IO size, etc., the above parameters cannot be set.
- If the safety communication is not established, safety functions on module also cannot be activated. Establish safety communication according to the instruction manual of the safety controller used.
- If the Module has already is set in another network, it may not be possible to set the parameter (e.g. SNN, TUNID). Please perform a safety reset as necessary.

4.2.2. Safety reset on CIP safety

Safety IO module supports the safety reset described in [Table 4.2-3](#). Execute the safety reset, you should enter the product-specific password in addition to the TUNID. The product-specific password can be changed for your responsibility. See [Table 4.2-4](#) for the CIP objects required for changing passwords and safety reset.

Table 4.2-3 Parameters for safety reset

Items	Specification																
Safety reset	Type0 -2: support																
Initial password	Byte	0	1	2	3	4	5	6	7	8	9	10	11	12	13	14	15
	Data [Hex]	45	58	36	30	30	53	41	46	45	5F	52	53	54	5F	50	57

Table 4.2-4 CIP object

Service	Class	Instance	Attribute	Description																										
0x0E	0x39	0x01	0x1B	Get the current TUNID. <ul style="list-style-type: none"> Default Value: FF FF FF FF FF FF FF FF FF FF (FF x 10byte) 																										
0x0E	0xC7	0x01	0x64	Get the password change history. <ul style="list-style-type: none"> 0: Password has not been changed from the default. 1: Password has been changed. 																										
0x4B	0xC7	0x01	-	Change the password for safety reset. <ul style="list-style-type: none"> Current password (16 bytes) + New password (16 bytes) <p>The following ASCII characters can be used for password</p> <ul style="list-style-type: none"> A – Z 0 – 9 _ (Underscore) 																										
0x54	0x39	0x01	-	Safety reset <ul style="list-style-type: none"> Safety reset type(1byte) + Current password (16byte) + TUNID (10byte) + Attribute bit map (1byte) “Attribute bit map” is only included when the safety reset type is 2. Other types don't have to include this data. Safety reset type <table border="1" data-bbox="715 1406 1426 1541"> <thead> <tr> <th>Value</th> <th>Type of reset</th> </tr> </thead> <tbody> <tr> <td>0x00</td> <td>Safety reset type0</td> </tr> <tr> <td>0x01</td> <td>Safety reset type1</td> </tr> <tr> <td>0x02</td> <td>Safety reset type2</td> </tr> </tbody> </table> Attribute bit map When set “0”, reset the parameters in the table below. And since set “1”, preserve the parameters in the table below. <table border="1" data-bbox="715 1697 1426 2002"> <thead> <tr> <th>Bit</th> <th>Attribute Bit Map Assignments</th> </tr> </thead> <tbody> <tr> <td>0</td> <td>Soft-set NodeId</td> </tr> <tr> <td>1</td> <td>Soft-set Communication Link Parameters</td> </tr> <tr> <td>2</td> <td>TUNID and CCUNID</td> </tr> <tr> <td>3</td> <td>Password</td> </tr> <tr> <td>4</td> <td>CFUNID</td> </tr> <tr> <td>5</td> <td>OCPUNID</td> </tr> <tr> <td>6</td> <td>Reserved</td> </tr> <tr> <td>7</td> <td>Reserved</td> </tr> </tbody> </table> 	Value	Type of reset	0x00	Safety reset type0	0x01	Safety reset type1	0x02	Safety reset type2	Bit	Attribute Bit Map Assignments	0	Soft-set NodeId	1	Soft-set Communication Link Parameters	2	TUNID and CCUNID	3	Password	4	CFUNID	5	OCPUNID	6	Reserved	7	Reserved
Value	Type of reset																													
0x00	Safety reset type0																													
0x01	Safety reset type1																													
0x02	Safety reset type2																													
Bit	Attribute Bit Map Assignments																													
0	Soft-set NodeId																													
1	Soft-set Communication Link Parameters																													
2	TUNID and CCUNID																													
3	Password																													
4	CFUNID																													
5	OCPUNID																													
6	Reserved																													
7	Reserved																													

! WARNING

- Please be aware that a Safety Reset initializes the module's settings. It should be completed by a competent person.
- The initial password can be changed at your responsibility. If you forget your password, you may not be using some functions properly (e.g. safety reset).
- If the changed password is forgotten, the module needs to be initialized. If you have forgotten your password, please contact us.

4.3. Process data

The safety IO module occupies the IO sizes described in [Table 4.3-1](#) in both the safe and non-safety process data areas. The detail of each process data is provided in this section.

Table 4.3-1 process data size of each function

Function	Input data area [Byte]	Output data area [Byte]	Remarks
Safety	6 fixed	10 fixed	Used for safety function control and monitor. See Table 4.3-2 for detail.
Non-safety	Up to 16	Up to 24	Used for non-safety function (e.g. valve / ITV control) control and monitoring. See Table 4.3-6 , Table 4.3-7 .

4.3.1. Safe process data

The safety process data on the safety IO module provides the following functions. The process data of the safety IO module is shown in [Table 4.3-2](#).

- Monitoring of safety input values
- Control of safety outputs
- Setting the parameters in the safety IO module.

Table 4.3-2 Safety process data IO map

Byte	Safety inputs data area	Safety outputs data area
0	Safety inputs: CN0-3	Safety outputs
1	Safety inputs: CN4-7	Parameter setting
2	Safety parameters readback: CN0/1	Safety parameters: CN0/1
3	Safety parameters readback: CN2/3	Safety parameters: CN2/3
4	Safety parameters readback: CN4/5	Safety parameters: CN4/5
5	Safety parameters readback: CN6/7	Safety parameters: CN6/7
6	Status byte1	-
7	Status byte2	-
8	Status byte3	-
9	Status byte4	-

4.3.1.1. Safety input process data

The safety input area is used to monitor the feedback from safety sensors and provide status of the safety IO module. It occupies a total of 10 Input Bytes;

- First 2 Bytes are for monitoring readback from safety sensors
- Next 4 Bytes are for monitoring the status of safety parameters
- Last 4 bytes are for providing module status.

Table 4.3-3 List of the safety inputs process data

Byte	Bit7	Bit6	Bit5	Bit4	Bit3	Bit2	Bit1	Bit0
0	Safety input (CN0-3)							
	IN7	IN6	IN5	IN4	IN3	IN2	IN1	IN0
1	Safety input (CN4-7)							
	IN15	IN14	IN13	IN12	IN11	IN10	IN9	IN8
2	Safety related parameter (CN0/1)							
	CN setting	Discrepancy time			Power source		Channel equivalent	
3	Safety related parameter (CN2/3)							
	CN setting	Discrepancy time			Power source		Channel equivalent	
4	Safety related parameter (CN4/5)							
	CN setting	Discrepancy time			Power source		Channel equivalent	
5	Safety related parameter (CN6/7)							
	CN setting	Discrepancy time			Power source		Channel equivalent	
6	Reserved	Safety outputs status bit			Safety inputs status bit			
	Reserved	Z3	Z2	Z1	CN6/7	CN4/5	CN2/3	CN0/1
7	Discrepancy time alarm				Parameter alarm			
	CN6/7	CN4/5	CN2/3	CN0/1	CN6/7	CN4/5	CN2/3	CN0/1
8	Cross circuit alarm				Short circuit alarm			
	CN6/7	CN4/5	CN2/3	CN0/1	CN6/7	CN4/5	CN2/3	CN0/1
9	Reserved	Short circuit alarm			24V_US2 alarm		24V_US1 alarm	
	Reserved	Z3	Z2	Z1	UVM	OVM	UVM	OVM

Attention

This chapter only provides the IO maps. Refer to the relevant section for instructions on how to use each bit.

- Byte 0-1 are shown the current value of the safety input. See [4.5 Safety inputs](#) for detail.
- Byte 2-5 are shown as the readback for the safety related parameter. See [4.4.1 Safe parameterization](#) for detail.
- Byte 6-9 are shown the status of the safety IO module. See [4.8.1 Safety related diagnostics](#).

4.3.1.2. Safety outputs process data

The safety output area is used to control the safety outputs and for setting safety parameters. It occupies total 6 Byte of Output area; The 1 Byte is for control safety output and other the 5 Byte is for setting parameter of the module.

Table 4.3-4 Safety outputs process data

Byte	Bit7	Bit6	Bit5	Bit4	Bit3	Bit2	Bit1	Bit0
0	Reserved					Z3	Z2	Z1
1	Reserved					Error Reset	Parameter setting	US2 undervoltage diagnostic
2	CN0/1 parameter setting area							
	CN setting	Discrepancy time		Power source		Channel equivalent		
3	CN2/3 parameter setting area							
	CN setting	Discrepancy time		Power source		Channel equivalent		
4	CN4/5 parameter setting area							
	CN setting	Discrepancy time		Power source		Channel equivalent		
5	CN6/7 parameter setting area							
	CN setting	Discrepancy time		Power source		Channel equivalent		

Attention

This chapter only provides the IO maps. Refer to the relevant section for instructions on how to use each bit.

- Byte 0 is for operating the safety outputs. See [4.6 Safety outputs](#) for detail.
- Byte1 Bit0-1 and Byte 2-5 is for set parameter: See [4.4 Safe parameterization](#) for detail.
- Byte 1 bit2 is for reset diagnostics. See [4.8.1 Safety related diagnostics](#) for detail.

4.3.2. Non-safety process data

The IO size of the non-safety process data is different for each product. See [Table 4.3-5](#). Non-safety process data occupies a different area to the safety process data. The total IO size depends on the valve manifold configuration. See the Fieldbus module instruction manual for detail.

Table 4.3-5 Process data size occupied by each product

Product number	Occupied input data	Occupied output data
EX600-FVC1	0 byte fixed	4 byte fixed
EX600-FVC2	16 byte fixed	Up to 24 byte
EX600-FVC3	0 byte fixed	Up to 16 byte
EX600-FVC4	16 byte fixed	Up to 24 byte

4.3.2.1. EX600-FVC1

Table 4.3-6 Non-safety process data of EX600-FVC1

Byte	Input	Output	Remark
0	-	Valve output Ch0-7	Valve output <ul style="list-style-type: none"> 0: OFF 1: ON Even number of bits: Solenoid valve side A. Odd number of bits: Solenoid valve side B.
1		Valve output Ch8-15	
2		Valve output Ch16-23	
3		Valve output Ch24-31	

4.3.2.2. EX600-FVC2 and EX600-FVC4

Table 4.3-7 Non-safety process data of EX600-FVC2 and EX600-FVC4

Byte	Input	Output	Remark
0	ITV module1	Valve output Ch0-7	ITV module <ul style="list-style-type: none"> Output pressure value Display the pressure values measured by the ITV module. See the operation manual of the ITV module series for details. Diagnostics Display the status of the ITV module. See the operation manual of the ITV module series for details. Set pressure value Set the data according to the operational pressure value. See the operation manual of the ITV module series for details. 0x0000: 0% 0x0FFF: 100% Valve output <ul style="list-style-type: none"> 0: OFF 1: ON Even number of bits: Solenoid valve side A. Odd number of bits: Solenoid valve side B.
1	Diagnostics	Valve output Ch8-15	
2	ITV module1	Valve output Ch16-23	
3	Output pressure value	Valve output Ch24-31	
4	ITV module2	Valve output Ch32-39	
5	Diagnostics	Valve output Ch40-47	
6	ITV module2	Valve output Ch48-55	
7	Output pressure value	Valve output Ch56-63	
8	ITV module3	Valve output Ch64-71	
9	Diagnostics	Valve output Ch72-79	
10	ITV module3	Valve output Ch80-87	
11	Output pressure value	Valve output Ch88-95	
12	ITV module4	Valve output Ch96-103	
13	Diagnostics	Valve output Ch104-111	
14	ITV module4	Valve output Ch112-119	
15	Output pressure value	Valve output Ch120-127	
16	-	ITV module1 Set pressure value	
17	-	ITV module2 Set pressure value	
18	-	ITV module3 Set pressure value	
19	-	ITV module4 Set pressure value	
20	-	ITV module1 Set pressure value	
21	-	ITV module2 Set pressure value	
22	-	ITV module3 Set pressure value	
23	-	ITV module4 Set pressure value	

Attention

- Valve output IO size depends on the number of connected valves. If the number of connected valves is less than [Table 4.3-7](#), the process data for the ITV module is moved up to a higher Byte.
- The IO map of the ITV module is always placed behind the valve module wherever the ITV is located.

4.3.2.3. EX600-FVC3

Table 4.3-8 Non-safety process data of EX600-FVC3

Byte	Input	Output	Remark
0		Valve output Ch0-7	<p><u>Valve output</u></p> <ul style="list-style-type: none"> · 0: OFF · 1: ON · Even number of bits: Solenoid valve side A. · Odd number of bits: Solenoid valve side B.
1		Valve output Ch8-15	
2		Valve output Ch16-23	
3		Valve output Ch24-31	
4		Valve output Ch32-39	
5		Valve output Ch40-47	
6		Valve output Ch48-55	
7		Valve output Ch56-63	
8		Valve output Ch64-71	
9		Valve output Ch72-79	
10		Valve output Ch80-87	
11		Valve output Ch88-95	
12		Valve output Ch96-103	
13		Valve output Ch104-111	
14		Valve output Ch112-119	
15		Valve output Ch120-127	

4.4. Parameterization

4.4.1. Safe parameterization

The safety-related parameter settings for the Safety IO module are described in this section. See [Fig. 4.4-1](#) for the procedure how set the safety parameters.

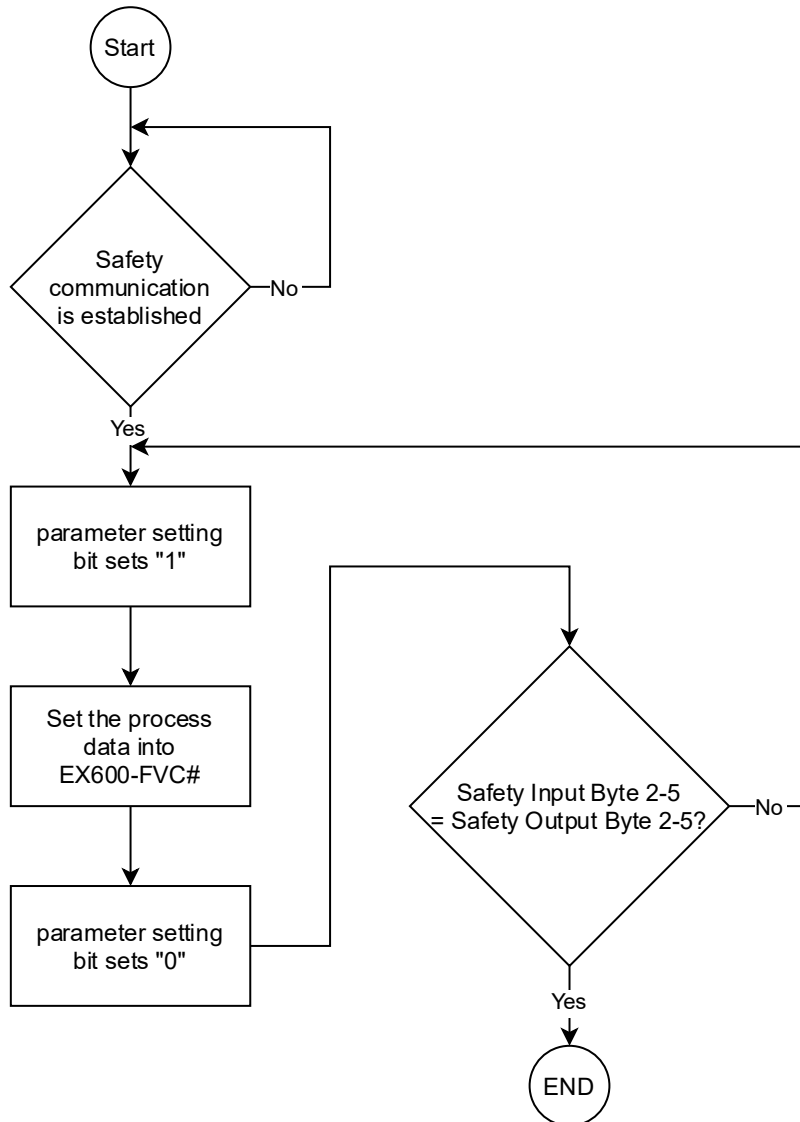

Fig. 4.4-1 Flow chart

WARNING

- All Safety functions are activated after safety parameter setting has been completed. To activate the safety functions of the Safety IO module, the setting of the safety parameters should be completed according to in this section.
- The EX600 safety module does not have any parameters that set via the process data after the power is turned on. Please set the parameters every time the power is turned on again.

Safety parameters of the safety IO module can be set to use on the safety output process data in Byte 1-5. See [Table 4.4-1](#) and [Table 4.4-2](#) for process data used for setting safety parameters.

Byte	Safety inputs area	Safety outputs area
0	Safety inputs: CN0-3	Safety outputs
1	Safety inputs: CN4-7	Parameter setting
2	Safety parameters readback: CN0/1	Safety parameters: CN0/1
3	Safety parameters readback: CN2/3	Safety parameters: CN2/3
4	Safety parameters readback: CN4/5	Safety parameters: CN4/5
5	Safety parameters readback: CN6/7	Safety parameters: CN6/7
6 - 9	Status byte1 - Status byte4	-

Table 4.4-1 Byte1 in safe output area

Byte	Bit	Description	Remark
1	0	US2 undervoltage diagnostic bit	Please check the "Attention" below to use of each bit.
	1	Parameter setting bit	
	2	Error reset bit	
	3 - 7	Reserved	

WARNING

- Before setting safety parameters, all wiring and installation should be complete. The module may detect diagnostics if wiring does not match the system architecture set by the parameter setting.
- When the "Parameter setting bit" is set to "1", the module shifts to the safe state immediately. When operating this bit, please use it with care and be aware of your environment.

Attention

- **US2 undervoltage diagnostic bit**
This bit sets the diagnostic behaviour at under voltage detection of US2. The setting of this parameter is set in the Safety IO module at the OFF edge of the "Parameter setting bit". When an undervoltage is detected, the safety output of the Safety IO module will be shifted to a safe state regardless of the setting of this bit.
 - 0: Disable
No diagnostic alarm when US2 is under voltage and the status LED does not change. When the supply voltage of US2 returns within the specification range, the system shall return to the normal state without a reset request.
 - 1: Enable
Diagnostic alarm occurs when US2 is under voltage and the status LED displays the error blinking pattern. When the supply voltage of US2 returns within the specification range, the system shall request a reset to the Safety IO module.
- **Parameter setting bit**
 - 1 → 0 (OFF edge): Set parameter into the safety IO module.
 - 1: The safety IO module will wait for the parameter settings to be entered
 - 0: Do nothing This bit set and reset the safety parameters on the safety IO module.
- **Error reset bit**
This bit provides to reset the diagnostics on the safety IO module. The only errors that can be reset with this bit are minor errors (e.g., US1/US2 voltage monitoring, Short circuit detection). See [4.8.1 Safety related diagnostics](#) for more information.
 - 1 → 0 (OFF edge): Reset diagnostic.
 - 0/1: Do nothing

Byte	Safety inputs area	Safety outputs area
0	Safety inputs: CN0-3	Safety outputs
1	Safety inputs: CN4-7	Parameter setting
2	Safety parameters readback: CN0/1	Safety parameters: CN0/1
3	Safety parameters readback: CN2/3	Safety parameters: CN2/3
4	Safety parameters readback: CN4/5	Safety parameters: CN4/5
5	Safety parameters readback: CN6/7	Safety parameters: CN6/7
6 - 9	Status byte1 - Status byte4	-

Table 4.4-2 Byte2-5 in safe output area

Byte	Bit	Description	Remark
2-5	0	Channel equivalent	<ul style="list-style-type: none"> • Byte2: parameter setting area for CN0/1 • Byte3: parameter setting area for CN2/3 • Byte4: parameter setting area for CN4/5 • Byte5: parameter setting area for CN6/7
	1		
	2	Power source	
	3		
	4	Discrepancy time	
	5		
	6		
7	CN setting		

WARNING

- The parameters should be checked the intended values when setting the safety parameters. The Safety input area (Byte 2-5) should be used to confirm the settings of the safety parameters by comparing them with the Safety output area (Byte 2-5) and ensuring they match.
- Safety parameters shall be set by a competent person.

Table 4.4-3 Detail of Byte2-5

Bit1		Bit0	Channel equivalent
0		0	Reserved
0		1	1oo1
1		0	1oo2 non-equivalent
1		1	1oo2 equivalent
Bit3		Bit2	Power source
0		0	Reserved
0		1	INx & INx+1 power source UTx with clock pulse (UTx = UT1-4)
1		0	INx power source: UTx with clock pulse (UTx = UT1-4) INx+1 power source: UT5 with clock pulse
1		1	INx & INx+1 power source: each power sources, without clock pulse
Bit6	Bit5	Bit4	Discrepancy time
0	0	0	Reserved
0	0	1	16ms
0	1	0	50ms
0	1	1	100ms
1	0	0	500ms
1	0	1	1s
1	1	0	No limit
1	1	1	Reserved
Bit7			CN setting
0			Disable
1			Enable

WARNING

- UT5 is a common power supply used by all safety input connectors. When “Power source: UT5” is set for any safety input connector on the module, the clock pulse of UT5 is enabled on all connectors.
- When “1oo1” is set in Channel equivalent bit, “Discrepancy time” should be set to “No limit”. Any other value will be invalid and the parameter setting will not complete successfully.
- When “INx & INx+1 power source: each power source” is set, the cross-circuit diagnostic is disabled on configured connectors. This mode may be used, for example, when connecting OSSD devices.
- When CN setting bit is set “Disable”, Send to upper controller the relevant safety input process data is “0” regardless of the status of the external safety sensor.

Attention

- Channel equivalent bit
This bit for selecting the input value evaluation bit mode (1oo1/1oo2) for input signals (IN0-15). See [4.5 Safety inputs](#) for detail.
- Power source bit
This bit specifies which power supply is used for the input signals. A cross-circuit of a sensor or cable can only be detected if the clock pulse is enabled for the specified power supply. Module may detect a fault if the wiring differs from the parameters set as well.
- Discrepancy time bit
This bit for selecting the allowable time for a gap between the two input signals. This parameter can only be set when 1oo2 is set in the Channel equivalent bit.
- CN setting bit
This bit for selecting whether the relevant connector is active.

Byte	Safety inputs area	Safety outputs area
0	Safety inputs: CN0-3	Safety outputs
1	Safety inputs: CN4-7	Parameter setting
2	Safety parameters readback: CN0/1	Safety parameters: CN0/1
3	Safety parameters readback: CN2/3	Safety parameters: CN2/3
4	Safety parameters readback: CN4/5	Safety parameters: CN4/5
5	Safety parameters readback: CN6/7	Safety parameters: CN6/7
6-9	Status byte1 - Status byte4	-

Table 4.4-4 Byte 2-5 in the input area

Byte	Bit	Description	Remark
2-5	0	Channel equivalent	<ul style="list-style-type: none"> Byte2: Readback for CN0/1 parameter setting Byte3: Readback for CN2/3 parameter setting Byte4: Readback for CN4/5 parameter setting Byte5: Readback for CN6/7 parameter setting
	1		
	2	Power source	
	3		
	4	Discrepancy time	
	5		
	6		
7	CN setting		

WARNING

- The Safety input area (Byte 2-5) should be used to confirm the settings of the parameters by comparing them with the Safety output area (Byte 2-5) and ensuring they match. If these Bytes are mismatched, all safety functions of the safety IO module cannot be used. The parameters should be checked the intended values when setting the parameters.

Attention

- Safety input process data Byte 2-5 display the same value as [Table 4.4-2](#) except the following conditions. When the following conditions are detected, all values show to "0" in this area.
 - Parameter setting bit (safety output process data Byte1_Bit1) is "1".
 - Parameter setting value is Invalid or unset.
 - CN setting bit (safety output process data Byte2-5 Bit 7) is "0"

4.4.2. Non-safety parameterization

Safety IO module also has non-safety parameters (valve ON/OFF count, ITV module-related parameters) which independently of the safety parameters. For the non-safety parameter for the Safety IO module, see the operation manual for Fieldbus module. The non-safety parameters are stored internal memory in the safety module and are retained even when the power is turned off.

4.5. Safety inputs

4.5.1. Power supply for sensors

The operating specification of power supply for sensor (UTx) is vary according to the safety-related parameters settings. See [Table 4.5-1](#).

Table 4.5-1 Specific for UTx

Power source setting	Clock pulse	Cross-circuit detection
INx & INx+1: UTx	With clock pulse	Yes
INx: UTx, INx+1: UT5	With clock pulse	Yes
INx & INx+1: each power sources	Without clock pulse	No

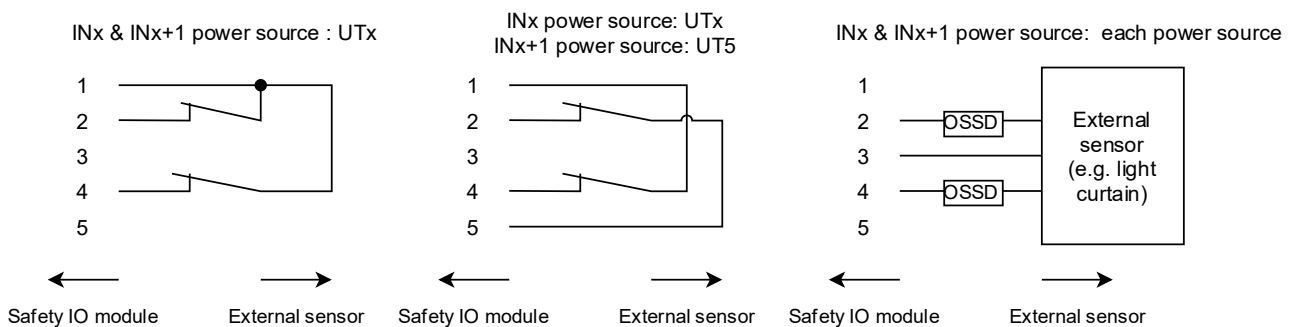

Fig. 4.5-1 Wiring example

! WARNING

- When using a safety controller (e.g. PLC) to connect to the Safety IO module, ensure that the 0V is common between both controller and module.
- Do not connect actuators to the UTx of the Safety IO module; the UTx is not a safety power supply for the drive.
- When connecting OSSD devices to the Safety IO module, inrush currents may occur in the UTx supplying the sensor. This may cause the UTx in the relevant area not to function properly. When connecting OSSD devices to the Safety IO module, check the current consumption and start-up current of the device used and consider supplying power to the device with a separate power supply if necessary.
- When connecting a sensor with an internal capacitor component, such as an OSSD device to UTx, the Clock pulse should be set to Disable. If Clock pulse is used with Enable, the UTx Clock pulse may fail and the module may detect a failure.
- When supplying a separate power supply to your device, make sure that common (0 V) is at the same potential as the Safety IO module. If the potential is not on the same module, the safety functions may not work properly.
- When connecting devices to the Safety IO module, they should be connected/wired before the Safety IO module is switched on. If the devices used are connected to the Safety IO module after the Safety IO module is switched on, the function of the Safety IO module and your device may be damaged (hot plugging).

! Caution

- If the voltage supplied to the Safety IO module is outside the operating range, the UTx may not start up properly. Check the supply voltage when the module detects an overvoltage or undervoltage. In some cases, the Safety IO module may need to be switched on again.
- If UTx detects an error (e.g.: short circuit, Cross circuit), please follow the troubleshooting instructions to recover from the failure. See [6.2 Troubleshooting](#) for detail.

4.5.2. Safety input

Safety input status can monitor in the safety process input data in Byte0-1. See [Table 4.5-2](#) for the connectors and pin layouts corresponding to the process data for each safety input.

Byte	Safety inputs area	Safety outputs area
0	Safety inputs: CN0-3	Safety outputs
1	Safety inputs: CN4-7	Parameter setting
2	Safety parameters readback: CN0/1	Safety parameters: CN0/1
3	Safety parameters readback: CN2/3	Safety parameters: CN2/3
4	Safety parameters readback: CN4/5	Safety parameters: CN4/5
5	Safety parameters readback: CN6/7	Safety parameters: CN6/7
6 - 9	Status byte1 - Status byte4	-

Table 4.5-2 Byte0 in the input area

Byte	Bit	Description	Connector No.	Pin No.	Explanation
0	0	Input status of IN 0	CN0	4	0: OFF, 1: ON
	1	Input status of IN 1	CN0	2	0: OFF, 1: ON
	2	Input status of IN 2	CN1	4	0: OFF, 1: ON
	3	Input status of IN 3	CN1	2	0: OFF, 1: ON
	4	Input status of IN 4	CN2	4	0: OFF, 1: ON
	5	Input status of IN 5	CN2	2	0: OFF, 1: ON
	6	Input status of IN 6	CN3	4	0: OFF, 1: ON
	7	Input status of IN 7	CN3	2	0: OFF, 1: ON
1	0	Input status of IN 8	CN4	4	0: OFF, 1: ON
	1	Input status of IN 9	CN4	2	0: OFF, 1: ON
	2	Input status of IN 10	CN5	4	0: OFF, 1: ON
	3	Input status of IN 11	CN5	2	0: OFF, 1: ON
	4	Input status of IN 12	CN6	4	0: OFF, 1: ON
	5	Input status of IN 13	CN6	2	0: OFF, 1: ON
	6	Input status of IN 14	CN7	4	0: OFF, 1: ON
	7	Input status of IN 15	CN7	2	0: OFF, 1: ON

WARNING

- The safety input process data depends on the parameters to be set in the module. Qualified personnel should check the conditions under which the process data values change and set the parameters appropriately.
- When connecting an OSSD device to the EX600-FV##, the safety input signal of the module may follow the test-pulse cycle of the OSSD device and be detected as OFF. If you do not want the module's safety input to be turned OFF by the test pulses of the OSSD device, please configure a filter with a response time (21 ms) or longer for the corresponding safety input signal in your application program.

Attention

The process data of Byte 0-1 depends on the parameter set in the module. See [Table 4.5-3](#) for the behavior of the safety inputs.

Table 4.5-3 Process data status for the safety input

Actual input (e.g. Sensor's output)		Process data							
		1oo1		1oo2 Equivalent		1oo2 Non-equivalent		CN setting: Disable	
Input signal x	Input signal x+1	INx	INx+1	INx	INx+1	INx	INx+1	INx	INx+1
Low	Low	0	0	0	0	0	0	0	0
Low	High	0	1	0	0	0	0	0	0
High	Low	1	0	0	0	1	0	0	0
High	High	1	1	1	0	0	0	0	0

⚠ Caution

See [5.2 General specifications](#) for the voltage levels at which actual input becomes High/Low.

Attention

Discrepancy between two input signals is evaluated in the module when "1oo2" is specified. Detects diagnostics when the time difference between a change of state in the two input signals exceeds the specified discrepancy time. See [Fig. 4.5-2](#) for the image.

1oo2 equivalent

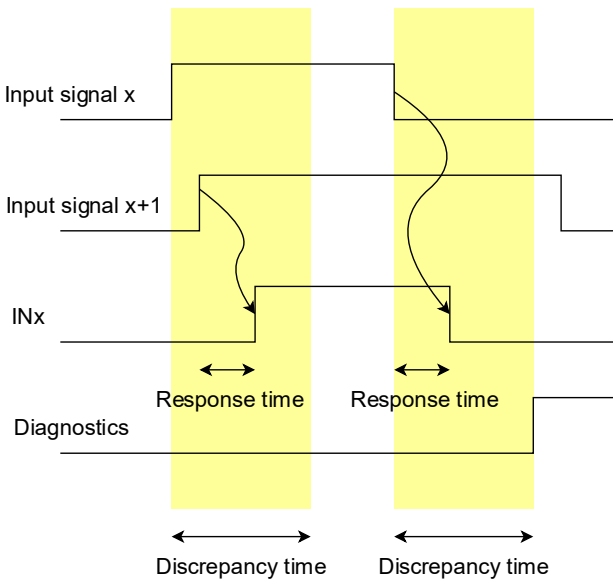

1oo2 non-equivalent

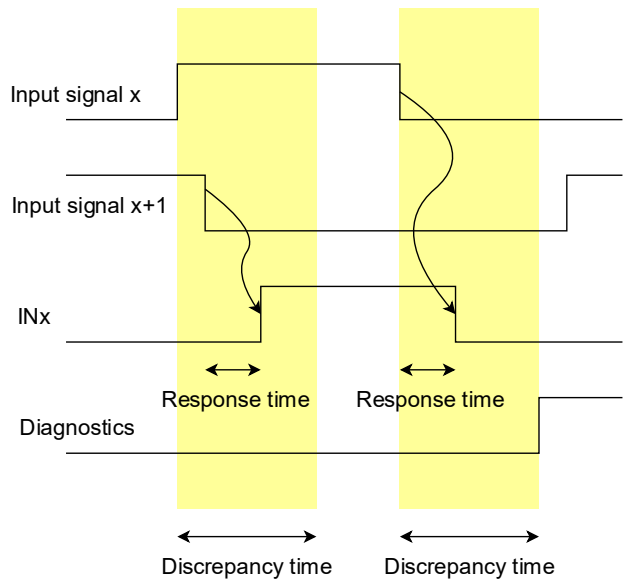

Fig. 4.5-2 Discrepancy time

4.6. Safety outputs

Safety output status can handle the safety process output data in Byte0. The safety IO module has a total of 3 safety power supplies for outputs and each safety output can be handled individually. See [Table 2.4-1](#) for the output destination for safe output.

Byte	Safety inputs area	Safety outputs area
0	Safety inputs: CN0-3	Safety outputs
1	Safety inputs: CN4-7	Parameter setting
2	Safety parameters readback: CN0/1	Safety parameters: CN0/1
3	Safety parameters readback: CN2/3	Safety parameters: CN2/3
4	Safety parameters readback: CN4/5	Safety parameters: CN4/5
5	Safety parameters readback: CN6/7	Safety parameters: CN6/7
6 - 9	Status byte1 - Status byte4	-

Table 4.6-1 Byte0 in the output area

Byte	Bit	Description	Explanation
0	0	Safe power supply of Z1	0: OFF, 1: ON
	1	Safe power supply of Z2	0: OFF, 1: ON
	2	Safe power supply of Z3	0: OFF, 1: ON
	3 - 7	Reserved	-

WARNING

- Safety outputs are only available for systems that are made safe by switching off the power supply. E.g.: A system whereby the power supply to the valve module is safely switched off, so that the valve is safely shut down.
- The safety outputs of the Safety IO module output a clock pulse at regular intervals for diagnostics. Depending on the internal circuitry of the device connected to the safety outputs (Z1-Z3), the clock pulse may have an effect.
- The safety output will be enabled after the safety parameters have been set. The safety output will be maintained safe state until the parameter setting is complete.

Attention

- Z1-3 consists of two safety outputs; One is high side output (24V), the other is low side common output (0V). These switches are switched on simultaneously when the Z1-3 get ON instruction from upper safety controller.
- Examples of devices that can be connected to the safety outputs of the Safety IO module.
 - Devices with no or low capacitance.
 - Potential-free contacts such as relays, mechanical contacts, etc.

4.7. Solenoid valve and ITV module

The solenoid valve and ITV module are controlled using non-safety process data. The power supply for solenoid valve is supplied via safety output. Please be sure to turn the safety output ON to control the solenoid valve. Therefore, if the safety output is turned off for reasons such as communication line break, the valve output will be turned off regardless of the valve control content. The ITV module can be controlled regardless of the safety output state. See [5.4 Block diagrams](#) for reference.

4.8. Diagnostics

4.8.1. Safety related diagnostics

The diagnostics in the safety IO module can monitor the safety input process data. Please refer to [6.2 Troubleshooting](#) for the process data of each failure mode.

Byte	Safety inputs area	Safety outputs area
0	Safety inputs: CN0-3	Safety outputs
1	Safety inputs: CN4-7	Parameter setting
2	Safety parameters readback: CN0/1	Safety parameters: CN0/1
3	Safety parameters readback: CN2/3	Safety parameters: CN2/3
4	Safety parameters readback: CN4/5	Safety parameters: CN4/5
5	Safety parameters readback: CN6/7	Safety parameters: CN6/7
6	Status byte1	-
7	Status byte2	-
8	Status byte3	-
9	Status byte4	-

Table 4.8-1 Status byte1: Byte6 in safety inputs area

Byte	Bit	Description	Explanation
6	0	Status bit of CN0/1	0: Input function is in the safe state. 1: Input function is active and can be used. No error.
	1	Status bit of CN2/3	
	2	Status bit of CN4/5	
	3	Status bit of CN6/7	0: Output function is in the safe state. 1: Output function is active and can be used. No error.
	4	Status bit of Z1	
	5	Status bit of Z2	
	6	Status bit of Z3	
7	Reserved	-	

Caution

- When the bit shows “0”, remove the cause of the fault by reading the status LEDs (e.g. FDI, FDO) and the process input data Byte 7-9 to take corrective action.

Table 4.8-2 Status byte2: Byte7 in the input area

Byte	Bit	Description	Explanation
7	0	Parameter alarm bit: CN0/1	0: Detects setting parameter is invalid or parameter is not set yet. 1: No error.
	1	Parameter alarm bit: CN2/3	
	2	Parameter alarm bit: CN4/5	
	3	Parameter alarm bit: CN6/7	0: Discrepancy time is not in the permitted range, or parameter setting incomplete. 1: No error
	4	Discrepancy time alarm bit: CN0/1	
	5	Discrepancy time alarm bit: CN2/3	
	6	Discrepancy time alarm bit: CN4/5	
7	Discrepancy time alarm bit: CN6/7		

Caution

- When detects setting parameter is invalid, should be set correct parameter again. Safety functions are activated after parameter setting has been completed.

Table 4.8-3 Status byte3: Byte8 in the input area

Byte	Bit	Description	Explanation
8	0	Short circuit alarm bit: CN0/1	0:Detect short circuit on related UTx 1: No alarm
	1	Short circuit alarm bit: CN2/3	
	2	Short circuit alarm bit: CN4/5	
	3	Short circuit alarm bit: CN6/7	
	4	Cross circuit alarm bit: CN0/1	0:Detect cross circuit, or parameter setting incomplete. 1: No alarm
	5	Cross circuit alarm bit: CN2/3	
	6	Cross circuit alarm bit: CN4/5	
	7	Cross circuit alarm bit: CN6/7	

Attention

- When a short circuit is detected in UT5, all "Short circuit alarm bit" are shifted to "0". When a short circuit is detected in UTx (x=1-4), related "Short circuit alarm bit" is shifted to "0"

Table 4.8-4 Status byte4: Byte9 in the input area

Byte	Bit	Description	Explanation
9	0	24V US1 OVM alarm bit	0: Detect supply voltage is not in the permitted range. 1: No alarm
	1	24V US1 UVM alarm bit	
	2	24V US2 OVM alarm bit	
	3	24V US2 UVM alarm bit	
	4	Short circuit alarm: Z1	0:Detect short circuit in related Zx 1: No alarm
	5	Short circuit alarm: Z2	
	6	Short circuit alarm: Z3	
	7	Reserved	-

WARNING

- US1 and US2 power system has overvoltage protection function. This function is activated when a supplied voltage exceeding the overvoltage monitoring voltage (e.g. 24V + 20%).
- Once the overvoltage protection function of US1 or US2 is activated, all functions related power supply system (US1 or US2) will be shifted to a safe state and the module will need to be replaced. Please use the power supply within the specified range.

Caution

- US1 is the control power supply; when a voltage fault is detected at US1, all safety functions shift to the safe state.
- US2 is the drive power supply; when a voltage fault is detected at US2, safety output functions shift to the safe state.

Attention

- Behaviour when "US2 undervoltage diagnostic bit" in safety output Byte1 is set to "0: Disable" No diagnostic alarm and status LED does not change. When the supply voltage of the US2 returns within the specification range, the module return to the normal state without error reset request procedure.
- Behaviour when "US2 undervoltage diagnostic bit" in safety output Byte1 is set to "1: Enable" Diagnostic alarm occurs when US2 undervoltage occurs and the status LED displays the error blinking pattern. When the supply voltage of the US2 returns within the specification range, the module request error reset procedure is also required.

4.8.2. Error reset for safety related diagnostics

When a fault is detected in the Safety IO module, it can be reset in the following ways. Please refer to [6.2 Troubleshooting](#) for the reset procedure of each failure mode.

- Use error reset bit in safety output Byte1 bit3
- Reset by fieldbus protocol supported functions (e.g. safety reset type 0-2)
- Switch the Safety IO module back on again.

Attention

Error reset bit can only reset errors which are shown in safety input process data Bytes 7-9. If faults are detected using bytes other than Bytes 7-9, reset the module using methods other than the Error reset bit.

4.8.3. Non-safety diagnostics and Error reset for non-safety related diagnostics

The non-safety diagnostics in the safety IO module can monitor the standard input process data or Explicit Messages on EtherNet/IP. See the fieldbus module operating instruction for more detail.

5. Technical specifications

5.1. Safety specifications

Table 5.1-1 Safety specifications

Item	Specification
Safety function	
Safety function	<ul style="list-style-type: none"> • Safety input • Safety output
SIL (EN61508/EN62061)	Up to SIL3
PL, Cat (EN ISO13849)	Up to PLe, Cat.3
DCavg	High ($\geq 99\%$)
MTTFd	<ul style="list-style-type: none"> • Safety input <ul style="list-style-type: none"> - 1oo1: High - 1oo2: High • Safety output: High
PFHd	<ul style="list-style-type: none"> • Safety input <ul style="list-style-type: none"> - 1oo1: 2.56E-10 1/h - 1oo2: 2.52E-10 1/h • Safety output: 2.53E-10 1/h
HFT	1
Classification	Type B
Mission time	20 years
Safety input	
Number of safety inputs	1oo1: Max.16 inputs 1oo2: Max. 8 inputs
Clock pulse width	Max. 1ms
Clock pulse interval	Max. 160ms
Response time to switch ON/OFF	Max. 21ms
Response time to channel fault	Max. 500ms
Safety output	
Number of safety outputs	3 safety outputs
Clock pulse width	Max. 1ms
Clock pulse interval	Max. 160ms
Response time to switch ON/OFF	Max. 21ms
Response time to channel fault	Max. 500ms

WARNING

In order to calculate the response time of a safety function, the worst-case response times of all components involved must be added to the delays on the communication paths.

5.2. General specifications

Table 5.2-1 General specifications

Item	Specification
Power	
Power for logic (US1) and valves (US2)	24V +20%, -15%
Internal current consumption	1150mA or less (24V_US1 and 24V_US2)
Galvanic isolation	Yes, between US1 and US2
Safety input	
Power source	US1
Power supply for sensor	Yes, via UT1-UT5
Max supplied current	<ul style="list-style-type: none"> · 2.0 A max. for the module · 0.6 A max. per UT (UT1-UT5)
Operating voltage	24V +20%, -15%
Input type	PNP, M12, 5pin, female
Input characteristic	IEC61131-2 Type3
Input current	Typ. 3.62 mA
ON voltage	11V to 30V
OFF voltage	-3V to 5V
Short circuit protection	Yes
Cross circuit detection	Yes
Voltage drops to sensor supply	Max. 1.2V
Safety output	
Power source	US2
Max supplied current	Module: 2.5A <ul style="list-style-type: none"> · EX600-FVC1/2 <ul style="list-style-type: none"> - Z1: 2A - Z2 and Z3: 0.25A / output · EX600-FVC3 <ul style="list-style-type: none"> - Z1: 2A - Z2 and Z3: 1A / output · EX600-FVC4 <ul style="list-style-type: none"> - Z1: 2A - Z2: 1A - Z3: 0.25A
Operating voltage	24V +20%, -15%
Short circuit protection	Yes
Voltage drops to valve supply	Max. 1.2V
Solenoid valve	
Applicable valve series	<ul style="list-style-type: none"> · SY series · JSY series · VQC series
Output type of solenoid	PNP
Short circuit protection	Yes
ITV module	
Number of max. connections	4 modules
Applicable safety IO module series	<ul style="list-style-type: none"> · EX600-FVC2 · EX600-FVC4
Short circuit protection	Yes
Protocol	
Protocol	CIP Safety™
General specification	
Protective structure	IP65, IP67
Operating temperature range	-10°C ≤ Temperature ≤ 50°C
Storage temperature range	-20°C ≤ Temperature ≤ 60°C
Operating humidity range	35% ≤ Humidity ≤ 85%RH (No condensation and no icing)
Altitude	Altitude ≤ 2,000m
Weight	540 g or less

Standard	
Standard	CE, UKCA, UL(CSA), EN61508, EN62061, ISO13849-1
Cable lengths*1	
Sensor cables	20m or less, with shields
Actuator cable	20m or less, with shields

*1) See [1.5.3 Insulation rating](#) for additional details.

Refer to the latest Declaration of Conformity of the authorized representative in the EU region (<https://www.smcworld.com>)

5.3. Production label

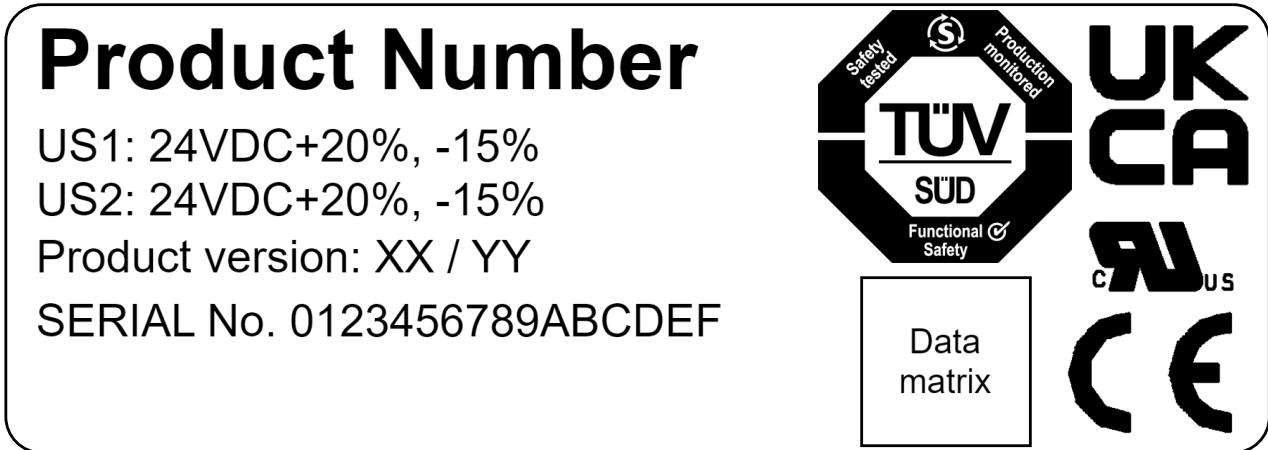

Fig. 5.3-1 Product label

- Product number example: EX600-FVC1
- Product version
 - XX: Safety related version, 1X and higher
 - YY: Non-safety related version, 10 and higher
 - See [Table 0-1.1-1](#) for details.

5.4. Block diagrams

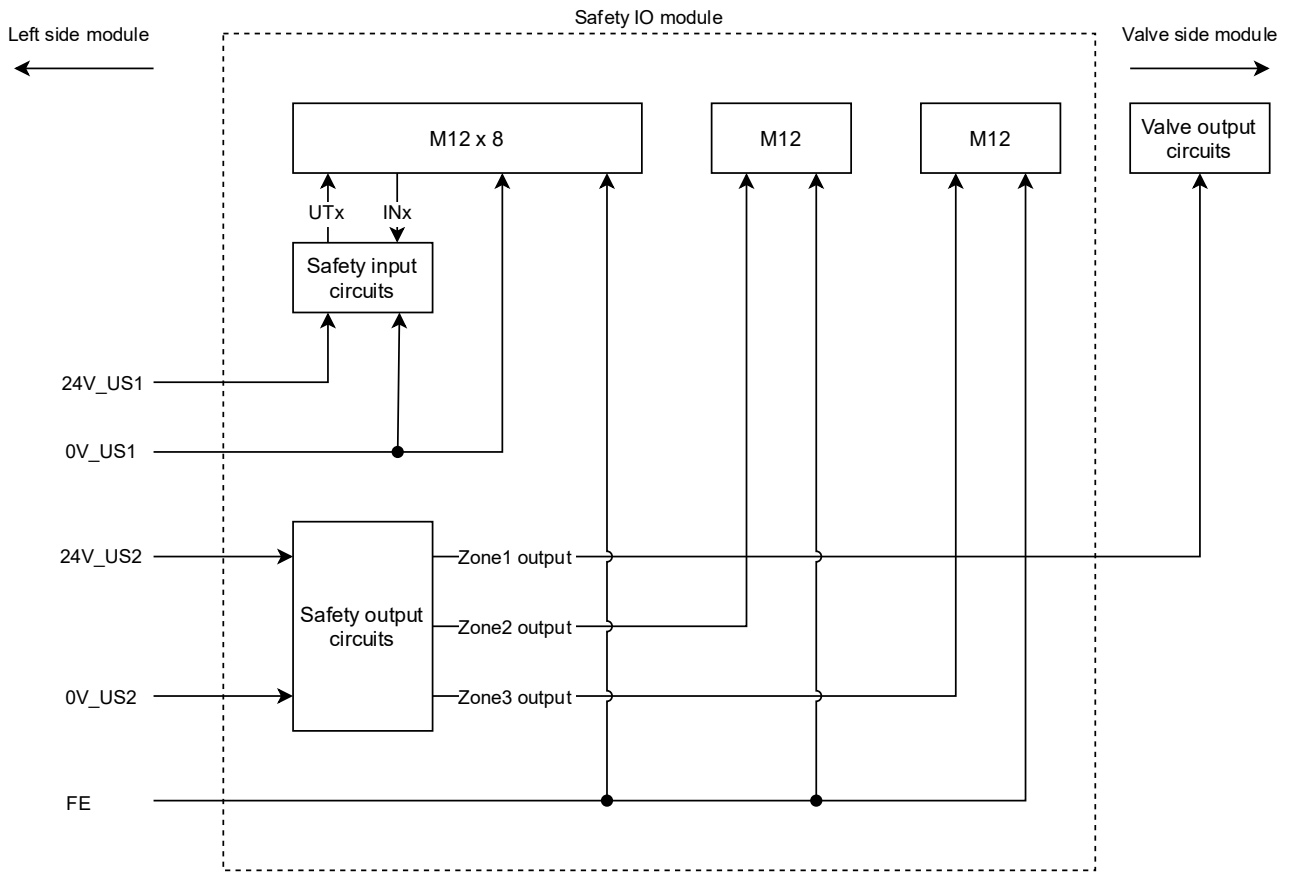

Fig. 5.4-1 EX600-FVC1

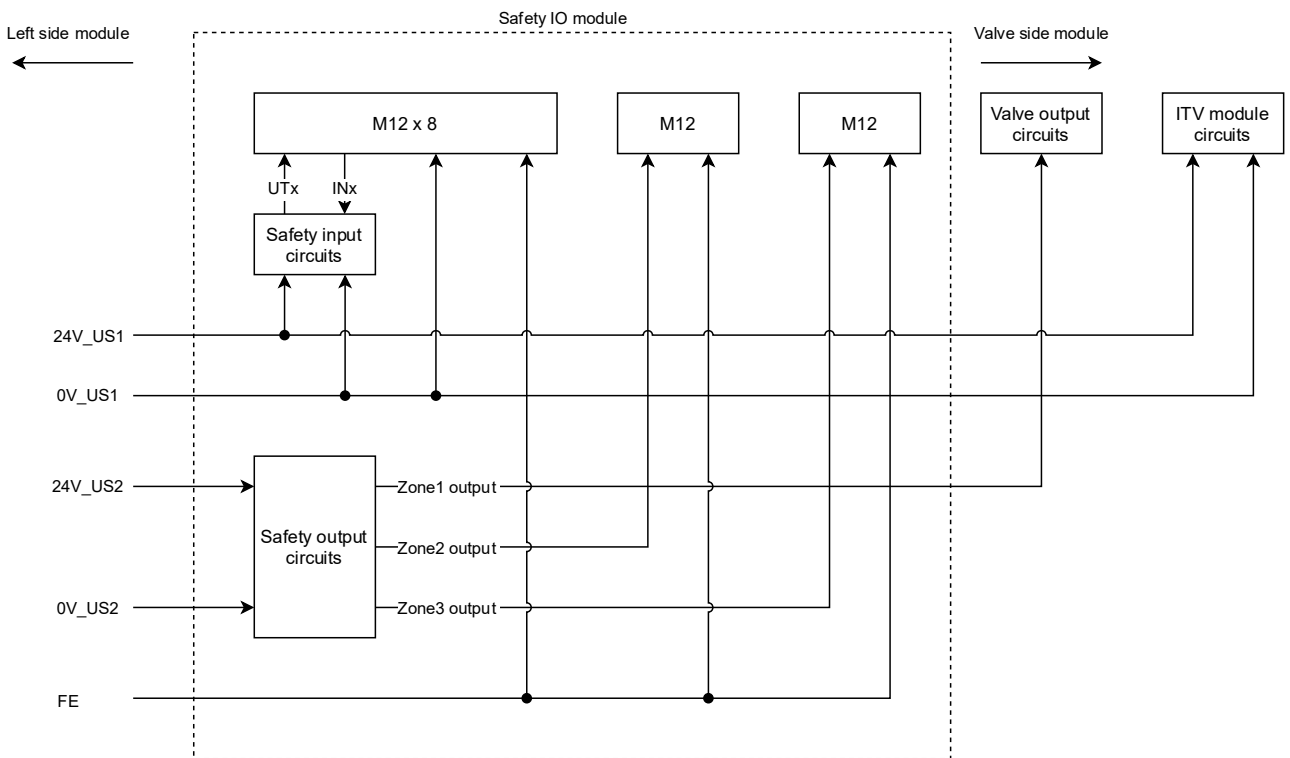

Fig. 5.4-2 EX600-FVC2

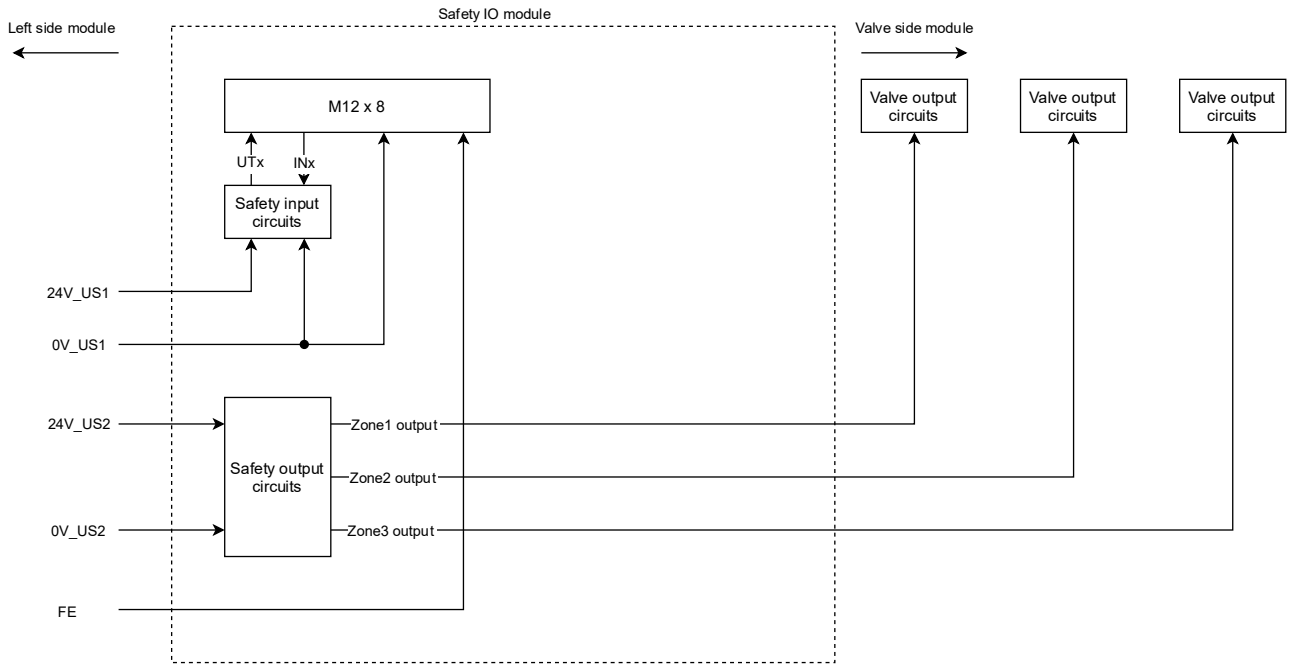

Fig. 5.4-3 EX600-FVC3

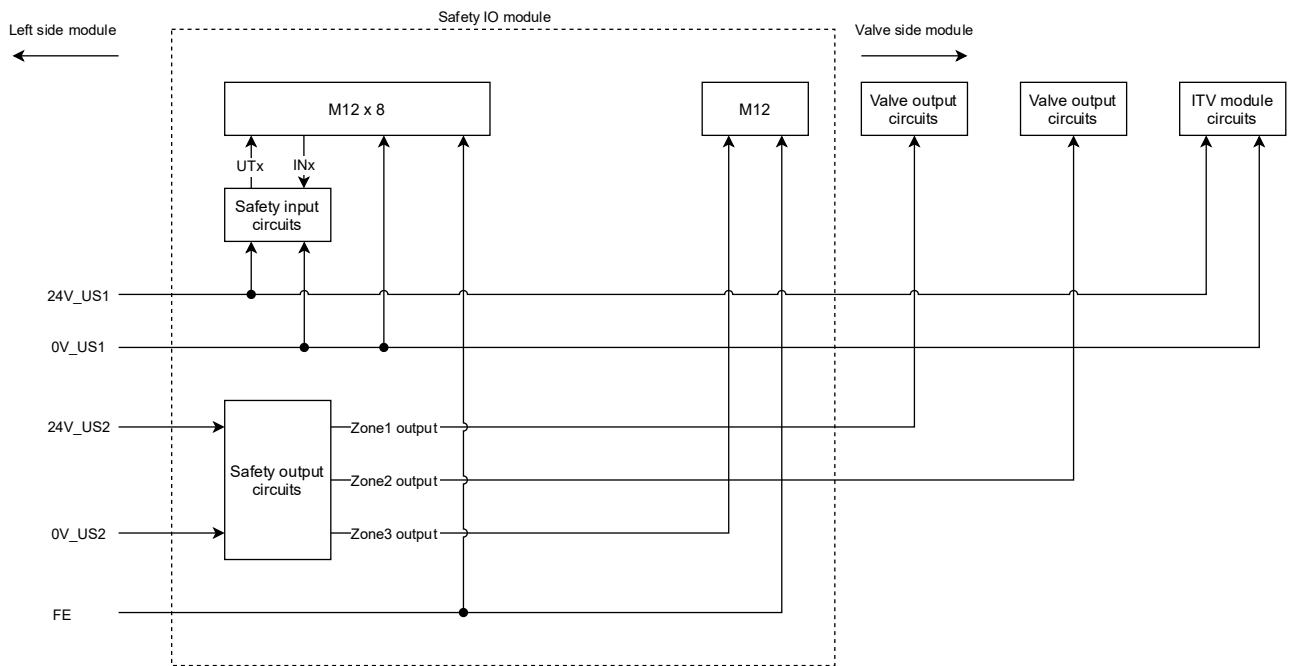

Fig. 5.4-4 EX600-FVC4

6. Appendix

6.1. Checklists

The checklists listed in this section provide support when carrying out the following tasks on the module planning, assembly and electrical installation, commissioning, parameterisation, and validation.

Attention

These checklists may be used as planning documentation and/or as verification to ensure the steps in the specified phases are carried out carefully.

Archive the completed checklists to use as reference for recurring tests.

The checklists do not replace the validation, initial commissioning, and regular testing performed by qualified personnel.

The following section of a checklist shows an example of a completed checklist.

Table 6.1-1 Example of a checklist

Checklist				
Device type/equipment identification		EX600-FVC1		
Product version	10 / 10	Date	2024-July-1st	
Creator	John Smith	Test engineer	Jane Brown	
Remark	System XXX has been checked for engine hood production			
No.	Requirement (mandatory)	Yes		Remark
X				
No.	Requirement (Option)	Yes	No	Remark
Y				

Key:

Equipment identification:

Enter the device type and/or the equipment identification for the relevant module.

Product version:

Enter the product version of the module as shown on the label on the Safety IO module. For details of the label on the module, see [5.3 Production label](#).

Date:

Enter the date on which you began to fill in this checklist.

Creator:

Enter the name of the person creating this checklist.

Test engineer:

Enter the name of the test engineer.

Remark:

Enter a remark, if necessary.

Requirement (mandatory):

These requirements must be met for a safety application, in order to complete the relevant phase using the checklist.

Requirement (optional):

These requirements are optional. For points that are not met, please enter an appropriate remark in the relevant field.

Table 6.1-2 Planning

Checklist for planning the use of the module				
Device type/equipment identification				
Product version		Date		
Creator		Test engineer		
Remark				
No.	Requirement (mandatory)	Yes		Remark
1	Has the current user manual for this product been used as the basis for planning?			Revision:
2	Are the valve manifold and selected valves approved for connection to the module (according to the technical data and parameterization options?)			
3	Has the voltage supply been planned according to the specifications for the protective extra-low voltage (PELV) or safety extra-low voltage (SELV)?			
4	Has the power supply of US1 and US2 from respective power supply units been planned?			
5	Is external protection for the module planned (according to the specifications in this user manual for supply voltage US1 and US2)			
6	Are measures planned to prevent simple manipulation of US1 and US2?			
7	Are measures planned to prevent connectors being mixed up?			
8	Are requirements for the actuators and cable installation specified according to the SIL/SILCL/Cat./PL to be achieved?			
9	Are the specifications for the parameterization defined?			
10	Are test intervals specified for testing the shutdown capability of the valves, if this is required to achieve a SIL/SILCL/Cat./PL?			
11	Has it been ensured that any person intentionally starting hazardous movements can only do so with a direct view of the danger zone?			
12	Does the planned use correspond to the intended use?			
13	Are the ambient conditions in conformity with the technical data?			
14	Have test intervals been defined?			
15	Has the switch-off delay for stop category 1 been observed in the calculation of the total response time for the machine/system?			
No.	Requirement (optional)	Yes	No	Remark
16	Have specifications for assembly and electrical installation been defined (e.g., EPLAN) and communicated to the relevant personnel?			
17	Have specifications for commissioning been defined and communicated to the relevant personnel?			
		Date		Signature (creator)
		Date		Signature (test engineer)

Table 6.1-3 Assembly and Electrical Installation

Checklist for Assembly and Electrical Installation of the module				
Device type/equipment identification				
Product version		Date		
Creator		Test engineer		
Remark				
No.	Requirement (mandatory)	Yes		Remark
1	Was assembly completed according to the specifications (specifications from the planning phase or according to the user manual)?			
2	Are all unused ports fitted with a seal cap?			
3	Do the cable cross sections and installation correspond to the specifications?			
4	Does the connection technology correspond to the specifications in the technical data and in the relevant user manual?			
No.	Requirement (optional)	Yes	No	Remark
5	Is the data width set correctly according to the specifications?			
6	Is the EtherNet/IP / CIP Safety address set correctly according to the specifications?			
		Date		Signature (creator)
		Date		Signature (test engineer)

Table 6.1-4 Commissioning and Parameterization

Checklist for commissioning and parameterization of the module				
Device type/equipment identification				
Product version		Date		
Creator		Test engineer		
Remark				
No.	Requirement (mandatory)	Yes		Remark
1	Was commissioning completed according to the specifications (specifications from the planning phase or according to the user manual)?			
2	During commissioning, is it ensured that any person intentionally starting hazardous movements can only do so with a direct view of the danger zone?			
3	Are all parameters parameterized for the safety inputs set correctly?			
4	If US2 diagnostics parameter is disabled, is a suitable countermeasure used?			
No.	Requirement (optional)	Yes	No	Remark
5	Have safety distances that must be observed been calculated according to the response and delay times implemented?			
		Date		Signature(creator)
		Date		Signature (test engineer)

Table 6.1-5 Validation

Checklist for validation			
Device type/equipment identification			
Product version		Date	
Creator		Test engineer	
Remark			
No.	Requirement (optional)	Yes	Remark
1	Have all the mandatory requirements for the "Planning" checklist been met?		
2	Have all the mandatory requirements for the "Assembly and electrical installation" checklist been met?		
3	Have all the mandatory requirements for the "Commissioning and parameterization" checklist been met?		
4	Does the wiring correspond to the approved wiring diagram?		
5	Has the assignment of the valves to the outputs and the variables of the safe application program been tested (online status in CIP Safety controller software)?		
6	Has a function test been performed to check all safety functions, in which the module is involved?		
7	Have measures been taken to achieve a specific SIL, PL and Cat.?		
8	Do all cables correspond to the specifications?		
9	Does the power supply correspond to the specifications for the protective extra-low voltage (PELV) or safety extra-low voltage (SELV)?		
10	Have the voltage supply of US1 and US2 from a power supply unit been correctly implemented?		
11	Is external protection of the module implemented (according to the specifications in this user manual for supply voltage US1 and US2)?		
12	Have measures been taken to prevent simple manipulation?		
13	Are the requirements for the valves and cable installation observed according to the SIL/SILCL/Cat./PL?		
14	Are test intervals specified for testing the shutdown capability of the actuators, if this is required to achieve a SIL/SILCL/Cat./PL?		
15	Has it been ensured that any person intentionally starting hazardous movements can only do so with a directly view of the danger zone?		
		Date	Signature (creator)
		Date	Signature (test engineer)

6.2. Troubleshooting

If a malfunction occurs in the Safety IO module, please follow the flowchart shows [Fig. 6.2-1](#) to identify the cause of the error and implement appropriate countermeasures.

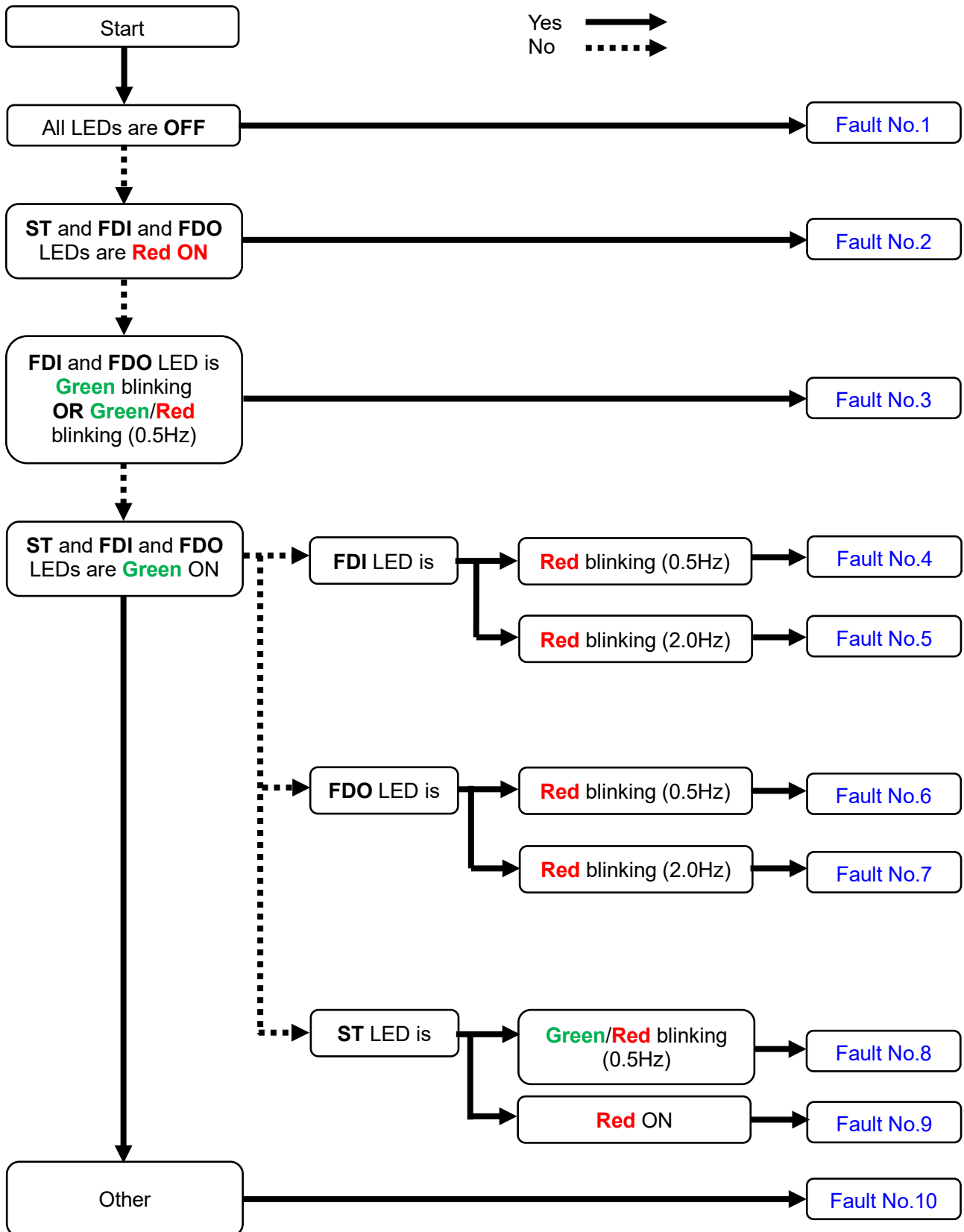

Fig. 6.2-1 Troubleshooting

6.2.1. Fault mode

6.2.1.1. Fault No.1

Table 6.2-1 All LEDs are OFF

Fault No.	Possible cause	Action
1	<ul style="list-style-type: none"> The US1 power supply is not supplied to the module. 	<ul style="list-style-type: none"> Supply power within the specifications of US1
	<ul style="list-style-type: none"> US1 is supplying a voltage within the specification range, but the Safety IO module is not starting up. All LEDs is turn OFF. 	<ul style="list-style-type: none"> Power cycle Replace the new safety IO module.

6.2.1.2. Fault No.2

Table 6.2-2 ST/FDI/FDO LEDs are Red

Fault No.	Possible cause	Action
2	<ul style="list-style-type: none"> Module may detect self-test error. Please power cycle again or execute safety reset to the module. If the problem persists after these countermeasures, please replace the module. See Table 6.2-3 for detail of the process data and LED. 	<ul style="list-style-type: none"> Power cycle Replace the new safety IO module.
	<ul style="list-style-type: none"> The module may already have TUNID set by another PLC. 	<ul style="list-style-type: none"> Set TUNID again

Table 6.2-3 Safety input process data and LED: self-test error

	Bit7	Bit6	Bit5	Bit4	Bit3	Bit2	Bit1	Bit0	LED	Status
Byte0	0	0	0	0	0	0	0	0	ST	Red ON
Byte1	0	0	0	0	0	0	0	0		
Byte2	0	0	0	0	0	0	0	0	FDI	Red ON
Byte3	0	0	0	0	0	0	0	0		
Byte4	0	0	0	0	0	0	0	0	FDO	Red ON
Byte5	0	0	0	0	0	0	0	0		
Byte6	0	0	0	0	0	0	0	0	INx	-
Byte7	0	0	0	0	0	0	0	0		
Byte8	0	0	0	0	0	0	0	0	Zx	-
Byte9	0	0	0	0	0	0	0	0		

6.2.1.3. Fault No.3

Table 6.2-4 FDI and FDO LED is Green blinking OR Green and Red blinking

Fault No.	Possible cause	Action
5	• Module has no parameter. See Table 6.2-5 for the detail of the process data and LED.	• Set parameter. See 4.4.1 Safe parameterization .
	• Set parameter is invalid. See Table 6.2-6 for the detail of the process data and LED.	• Set correct parameter again. See 4.4.1 Safe parameterization .

Table 6.2-5 Safety input process data and LED: Module has no parameter

	Bit7	Bit6	Bit5	Bit4	Bit3	Bit2	Bit1	Bit0	LED	Status
Byte0	-	-	-	-	-	-	-	-	ST	-
Byte1	-	-	-	-	-	-	-	-		
Byte2	0	0	0	0	0	0	0	0	FDI	Green blinking
Byte3	0	0	0	0	0	0	0	0		
Byte4	0	0	0	0	0	0	0	0	FDO	Green blinking
Byte5	0	0	0	0	0	0	0	0		
Byte6	-	0	0	0	0	0	0	0	INx	-
Byte7	-	-	-	-	0	0	0	0		
Byte8	-	-	-	-	-	-	-	-	Zx	-
Byte9	-	-	-	-	-	-	-	-		

-: Don't care

Table 6.2-6 Safety input process data and LED: Set parameter is invalid

	Bit7	Bit6	Bit5	Bit4	Bit3	Bit2	Bit1	Bit0	LED	Status
Byte0	-	-	-	-	-	-	-	-	ST	-
Byte1	-	-	-	-	-	-	-	-		
Byte2	0	0	0	0	0	0	0	0	FDI	Green/Red blinking
Byte3	0	0	0	0	0	0	0	0		
Byte4	0	0	0	0	0	0	0	0	FDO	Green/Red blinking
Byte5	0	0	0	0	0	0	0	0		
Byte6	-	0	0	0	0	0	0	0	INx	-
Byte7	-	-	-	-	0/1	0/1	0/1	0/1		
Byte8	-	-	-	-	-	-	-	-	Zx	-
Byte9	-	-	-	-	-	-	-	-		

-: Don't care

0/1: Only related bit shows "0"

6.2.1.4. Fault No.4

Table 6.2-7 FDI Red blinking (0.5Hz)

Fault No.	Possible cause	Action
4	<ul style="list-style-type: none"> UTx short circuit detected. See Table 6.2-8 for process data and LED details. Please check the following items. <ul style="list-style-type: none"> The sensor cable is not broken. The current consumption/inrush current of the connected sensor. 	<ul style="list-style-type: none"> After confirming the wiring and specification of connected sensor at the relevant safety input, apply one of the following reset methods. <ul style="list-style-type: none"> Reset bit (OFF edge) Power cycle Safety reset
	<ul style="list-style-type: none"> Cross circuit detected. See Table 6.2-9 for the process data and LED details. Please check the following items. <ul style="list-style-type: none"> The sensor cable is not broken. The wiring and parameter settings match. 	<ul style="list-style-type: none"> After confirming the wiring and parameters at the relevant safety input, apply one of the following reset methods. <ul style="list-style-type: none"> Reset bit (OFF edge) Power cycle Safety reset
	<ul style="list-style-type: none"> Detect the INx discrepancy time is outside the setting range. See Table 6.2-10 for process data and LED details. Please check the following items. <ul style="list-style-type: none"> The sensor discrepancy time is in the permitted range of the “discrepancy time” parameter. 	<ul style="list-style-type: none"> Set the correct parameter to the device again. The discrepancy alarm can be reset in the following way. <ul style="list-style-type: none"> Reset bit (OFF edge) Parameter setting bit is set “0 → 1”.
	<ul style="list-style-type: none"> The US1 power supply is outside the range. Supply power within the specifications of US1. See Table 6.2-11 for the detail of the process data and LED 	<ul style="list-style-type: none"> After supplying power within the specifications of US1, operate one of the following reset way. <ul style="list-style-type: none"> Reset bit (OFF edge) Power cycle Safety reset

WARNING

- For safety reasons, power supply to the Safety IO module must be switched off when checking for broken sensor cables.
- If you change the safety parameters, all safety functions (safety inputs and safety outputs) will be shifted to the safe state.

Table 6.2-8 Safety input process data and LED: Detect UTx short circuit

	Bit7	Bit6	Bit5	Bit4	Bit3	Bit2	Bit1	Bit0	LED	Status
Byte0	0/1	0/1	0/1	0/1	0/1	0/1	0/1	0/1	ST	-
Byte1	0/1	0/1	0/1	0/1	0/1	0/1	0/1	0/1		
Byte2	-	-	-	-	-	-	-	-	FDI	Red blinking (0.5Hz)
Byte3	-	-	-	-	-	-	-	-		
Byte4	-	-	-	-	-	-	-	-	FDO	-
Byte5	-	-	-	-	-	-	-	-		
Byte6	-	-	-	-	0/1	0/1	0/1	0/1	INx	Related: Red ON Other: -
Byte7	-	-	-	-	-	-	-	-		
Byte8	-	-	-	-	0/1	0/1	0/1	0/1	Zx	-
Byte9	-	-	-	-	-	-	-	-		

-: Don't care

0/1: Only related bit show "0"

Table 6.2-9 Safety input process data and LED: Detect cross circuit

	Bit7	Bit6	Bit5	Bit4	Bit3	Bit2	Bit1	Bit0	LED	Status
Byte0	0/1	0/1	0/1	0/1	0/1	0/1	0/1	0/1	ST	-
Byte1	0/1	0/1	0/1	0/1	0/1	0/1	0/1	0/1		
Byte2	-	-	-	-	-	-	-	-	FDI	Red blinking (0.5Hz)
Byte3	-	-	-	-	-	-	-	-		
Byte4	-	-	-	-	-	-	-	-	FDO	-
Byte5	-	-	-	-	-	-	-	-		
Byte6	-	-	-	-	0/1	0/1	0/1	0/1	INx	Related: Red ON Other: -
Byte7	-	-	-	-	-	-	-	-		
Byte8	0/1	0/1	0/1	0/1	-	-	-	-	Zx	
Byte9	-	-	-	-	-	-	-	-		

-: Don't care

0/1: Only related bit show "0"

Table 6.2-10 Process data and LED: Detect INx discrepancy time

	Bit7	Bit6	Bit5	Bit4	Bit3	Bit2	Bit1	Bit0	LED	Status
Byte0	0/1	0/1	0/1	0/1	0/1	0/1	0/1	0/1	ST	-
Byte1	0/1	0/1	0/1	0/1	0/1	0/1	0/1	0/1		
Byte2	-	-	-	-	-	-	-	-	FDI	Red blinking (0.5Hz)
Byte3	-	-	-	-	-	-	-	-		
Byte4	-	-	-	-	-	-	-	-	FDO	-
Byte5	-	-	-	-	-	-	-	-		
Byte6	-	-	-	-	0/1	0/1	0/1	0/1	INx	Related: Red ON Other: -
Byte7	0/1	0/1	0/1	0/1	-	-	-	-		
Byte8	-	-	-	-	-	-	-	-	Zx	
Byte9	-	-	-	-	-	-	-	-		

-: Don't care

0/1: Only related bit show "0"

Table 6.2-11 Safety input process data and LED: Detect US1 overvoltage or undervoltage

	Bit7	Bit6	Bit5	Bit4	Bit3	Bit2	Bit1	Bit0	LED	Status
Byte0	0	0	0	0	0	0	0	0	ST	-
Byte1	0	0	0	0	0	0	0	0		
Byte2	-	-	-	-	-	-	-	-	FDI	Red blinking (0.5Hz)
Byte3	-	-	-	-	-	-	-	-		
Byte4	-	-	-	-	-	-	-	-	FDO	Red blinking (0.5Hz)
Byte5	-	-	-	-	-	-	-	-		
Byte6	-	0	0	0	0	0	0	0	INx	-
Byte7	-	-	-	-	-	-	-	-		
Byte8	-	-	-	-	-	-	-	-	Zx	-
Byte9	-	-	-	-	-	-	*2	*1		

-: Don't care

*1: Byte9 bit0: When detect US1 overvoltage, this bit display "0"

*2: Byte9 bit1: When detect US1 undervoltage, this bit display "0"

6.2.1.5. Fault No.5

Table 6.2-12 FDI Red blinking (2.0Hz)

Fault No.	Possible cause	Action
5	<ul style="list-style-type: none"> Module may detect HW error (e.g. UTx stuck-at) in safety input function. See Table 6.2-13 for process data and LED details. Please check the following items. <ul style="list-style-type: none"> - Check the sensor cable is not broken. - Check that no other power source (24V) is connected to UTx. - The related UTx parameter should be set the clock pulse “Disable” when connected sensor has a large capacitance (e.g. light curtain). 	<ul style="list-style-type: none"> After confirming the wiring and parameters at the relevant safety input, apply one of the following reset methods. If the problem persists even after trying the following, please replace the module. <ul style="list-style-type: none"> - Power cycle - Safety reset
	<ul style="list-style-type: none"> Module may detect HW error (e.g. INx stuck at) in safety input function. See Table 6.2-14 for the detail of the process data and LED. 	<ul style="list-style-type: none"> After confirming the wiring and parameters at the relevant safety input, apply one of the following reset methods. If the problem persists even after trying the following, please replace the module. <ul style="list-style-type: none"> - Power cycle - Safety reset

Table 6.2-13 Safety input process data and LED: Detect UTx stuck at

	Bit7	Bit6	Bit5	Bit4	Bit3	Bit2	Bit1	Bit0	LED	Status
Byte0	0	0	0	0	0	0	0	0	ST	-
Byte1	0	0	0	0	0	0	0	0		
Byte2	-	-	-	-	-	-	-	-	FDI	Red blinking (2.0Hz)
Byte3	-	-	-	-	-	-	-	-		
Byte4	-	-	-	-	-	-	-	-	FDO	-
Byte5	-	-	-	-	-	-	-	-		
Byte6	-	-	-	-	0	0	0	0	INx	Red ON
Byte7	-	-	-	-	-	-	-	-		
Byte8	-	-	-	-	-	-	-	-	Zx	-
Byte9	-	-	-	-	-	-	-	-		

-: Don't care

Table 6.2-14 Safety input process data and LED: Detect HW error

	Bit7	Bit6	Bit5	Bit4	Bit3	Bit2	Bit1	Bit0	LED	Status
Byte0	0/1	0/1	0/1	0/1	0/1	0/1	0/1	0/1	ST	-
Byte1	0/1	0/1	0/1	0/1	0/1	0/1	0/1	0/1		
Byte2	-	-	-	-	-	-	-	-	FDI	Red blinking (2.0Hz)
Byte3	-	-	-	-	-	-	-	-		
Byte4	-	-	-	-	-	-	-	-	FDO	-
Byte5	-	-	-	-	-	-	-	-		
Byte6	-	-	-	-	0/1	0/1	0/1	0/1	INx	Related: Red ON Other: -
Byte7	-	-	-	-	-	-	-	-		
Byte8	0/1	0/1	0/1	0/1	-	-	-	-	Zx	
Byte9	-	-	-	-	-	-	-	-		

-: Don't care

0/1: Only related bit show "0"

6.2.1.6. Fault No.6

Table 6.2-15 FDO Red blinking (0.5Hz)

Fault No.	Possible cause	Action
6	<ul style="list-style-type: none"> The US1 power supply is outside the range. Supply power within the specifications of US1. See Table 6.2-16 for the detail of the process data and LED 	<ul style="list-style-type: none"> After supplying power within the specifications of US1, operate one of the following reset methods <ul style="list-style-type: none"> Reset bit (OFF edge) Power cycle Safety reset
	<ul style="list-style-type: none"> US2 overvoltage detected. Supply power within the specifications of US2. See Table 6.2-17 for process data and LED details. 	<ul style="list-style-type: none"> After supplying power within the specifications of US2, operate one of the following reset methods <ul style="list-style-type: none"> Reset bit(OFF edge) Power cycle Safety reset
	<ul style="list-style-type: none"> US2 undervoltage detected. Supply power within the specifications of US2. The behaviour depends on the parameter settings for US2_UVM. See 4.8.1 Safety related diagnostics and Table 6.2-18 for the detail of the process data and LED. 	
	<ul style="list-style-type: none"> US2 overvoltage protection is activated. See 4.8.1 Safety related diagnostics and Table 6.2-19 for the detail of the process data and LED. If the power cycle after overvoltage protection has been activated, a undervoltage may be detected depending on the parameter settings of US2_UVM. 	<ul style="list-style-type: none"> Replace the safety IO module.
	<ul style="list-style-type: none"> Related safety output short circuit detected. See Table 6.2-20 for the detail of the process data and LED 	<ul style="list-style-type: none"> After confirming the wiring at the relevant safety output, operate one of the following reset methods. <ul style="list-style-type: none"> Reset bit (OFF edge) Power cycle Safety reset

Table 6.2-16 Safety input process data and LED: Detect US1 overvoltage or undervoltage

	Bit7	Bit6	Bit5	Bit4	Bit3	Bit2	Bit1	Bit0	LED	Status
Byte0	0	0	0	0	0	0	0	0	ST	-
Byte1	0	0	0	0	0	0	0	0		
Byte2	-	-	-	-	-	-	-	-	FDI	Red blinking (0.5Hz)
Byte3	-	-	-	-	-	-	-	-		
Byte4	-	-	-	-	-	-	-	-	FDO	Red blinking (0.5Hz)
Byte5	-	-	-	-	-	-	-	-		
Byte6	-	0	0	0	0	0	0	0	INx	-
Byte7	-	-	-	-	-	-	-	-		
Byte8	-	-	-	-	-	-	-	-	Zx	-
Byte9	-	-	-	-	-	-	*	*		

-: Don't care

*:

- Byte9 bit0: When detect US1 overvoltage, this bit display "0"
- Byte9 bit1: When detect US1 undervoltage, this bit display "0"

Table 6.2-17 Safety input process data and LED: Detect US2_OVM

	Bit7	Bit6	Bit5	Bit4	Bit3	Bit2	Bit1	Bit0	LED	Status
Byte0	-	-	-	-	-	-	-	-	ST	-
Byte1	-	-	-	-	-	-	-	-		
Byte2	-	-	-	-	-	-	-	-	FDI	-
Byte3	-	-	-	-	-	-	-	-		
Byte4	-	-	-	-	-	-	-	-	FDO	Red blinking (0.5Hz)
Byte5	-	-	-	-	-	-	-	-		
Byte6	-	0	0	0	-	-	-	-	INx	-
Byte7	-	-	-	-	-	-	-	-		
Byte8	-	-	-	-	-	-	-	-	Zx	-
Byte9	-	-	-	-	-	0	-	-		

-: Don't care

Table 6.2-18 Safety input process data and LED: Detect US2_UVM

	Bit7	Bit6	Bit5	Bit4	Bit3	Bit2	Bit1	Bit0	LED	Status
Byte0	-	-	-	-	-	-	-	-	ST	-
Byte1	-	-	-	-	-	-	-	-		
Byte2	-	-	-	-	-	-	-	-	FDI	-
Byte3	-	-	-	-	-	-	-	-		
Byte4	-	-	-	-	-	-	-	-	FDO	Green ON, or Red blinking (0.5Hz)*
Byte5	-	-	-	-	-	-	-	-		
Byte6	-	0	0	0	-	-	-	-	INx	-
Byte7	-	-	-	-	-	-	-	-		
Byte8	-	-	-	-	-	-	-	-	Zx	-
Byte9	-	-	-	-	*	-	-	-		

-: Don't care

*:

- Byte9 bit3 and FDO LED: When US2 undervoltage diagnostics bit is "Enable" and detect US2 undervoltage this bit display "0" and FDO LED is Red blinking.
- Byte9 bit3 and FDO LED: When US2 undervoltage diagnostics bit is "Disable" and detect US2 undervoltage this bit display "1" and FDO LED is Green ON.

Table 6.2-19 Safety input process data and LED: Detect US2 overvoltage protection

	Bit7	Bit6	Bit5	Bit4	Bit3	Bit2	Bit1	Bit0	LED	Status
Byte0	-	-	-	-	-	-	-	-	ST	-
Byte1	-	-	-	-	-	-	-	-		
Byte2	-	-	-	-	-	-	-	-	FDI	-
Byte3	-	-	-	-	-	-	-	-		
Byte4	-	-	-	-	-	-	-	-	FDO	Red blinking (0.5Hz)
Byte5	-	-	-	-	-	-	-	-		
Byte6	-	0	0	0	-	-	-	-	INx	-
Byte7	-	-	-	-	-	-	-	-		
Byte8	-	-	-	-	-	-	-	-	Zx	-
Byte9	-	-	-	-	*	0	-	-		

-: Don't care

*:

- Byte9 bit3: When US2 undervoltage diagnostics bit is "Enable" and the power is turned back on after US2 overvoltage protection is activated, this bit display "0".
- Byte9 bit3: When US2 undervoltage diagnostics bit is "Disable" and the power is turned back on after US2 overvoltage protection is activated, this bit display "1".

Attention

- Once shifted to the US2 overvoltage protection mode, if the power is turned off and then back on again, depending on the setting of the US2 undervoltage diagnostics bit, the device behaves as detects a undervoltage.

Table 6.2-20 Safety input process data and LED: Detect Zx short circuit

	Bit7	Bit6	Bit5	Bit4	Bit3	Bit2	Bit1	Bit0	LED	Status
Byte0	-	-	-	-	-	-	-	-	ST	-
Byte1	-	-	-	-	-	-	-	-		
Byte2	-	-	-	-	-	-	-	-	FDI	-
Byte3	-	-	-	-	-	-	-	-		
Byte4	-	-	-	-	-	-	-	-	FDO	Red blinking (0.5Hz)
Byte5	-	-	-	-	-	-	-	-		
Byte6	-	0/1	0/1	0/1	-	-	-	-	INx	-
Byte7	-	-	-	-	-	-	-	-		
Byte8	-	-	-	-	-	-	-	-	Zx	Related: Red ON Other: -
Byte9	-	0/1	0/1	0/1	-	-	-	-		

-: Don't care

0/1: Only related bit show "0"

6.2.1.7. Fault No.7

Table 6.2-21 FDO Red blinking (2.0Hz)

Fault No.	Possible cause	Action
7	<ul style="list-style-type: none"> • Module may detect HW error (e.g. Zx stuck at). See Table 6.2-22 for process data and LED details. Please check the following items. If the problem persists after these countermeasures, please replace the module. <ul style="list-style-type: none"> - Check the wiring if external load connected to Zx. - Check that no other power source (24V) is connected to Zx. - A load that is not potential-free is connected to Zx. 	<ul style="list-style-type: none"> • After confirm the wiring at the relevant output, operate the following reset methods. If the problem persists even after trying the following, please replace the module. <ul style="list-style-type: none"> - Power cycle - Safety reset

Table 6.2-22 Safety input process data and LED: Detect HW error

	Bit7	Bit6	Bit5	Bit4	Bit3	Bit2	Bit1	Bit0	LED	Status
Byte0	-	-	-	-	-	-	-	-	ST	-
Byte1	-	-	-	-	-	-	-	-		
Byte2	-	-	-	-	-	-	-	-	FDI	-
Byte3	-	-	-	-	-	-	-	-		
Byte4	-	-	-	-	-	-	-	-	FDO	Red blinking (2.0Hz)
Byte5	-	-	-	-	-	-	-	-		
Byte6	-	0	0	0	-	-	-	-	INx	-
Byte7	-	-	-	-	-	-	-	-		
Byte8	-	-	-	-	-	-	-	-	Zx	Red ON
Byte9	-	-	-	-	-	-	-	-		

-: Don't care

6.2.1.8. Fault No.8

Table 6.2-23 ST Green and Red blinking

Fault No.	Possible cause	Action
8	<ul style="list-style-type: none"> Detect a short circuit on the valve module. See Table 6.2-24 for reference of the LED. 	<ul style="list-style-type: none"> After confirm the wiring at the relevant output, operate the following reset methods. If the problem persists even after trying the following, please replace the module. <ul style="list-style-type: none"> Power cycle Turn off the valve output at the short-circuit point. Turn off the all safety output(Z1-Z3)
	<ul style="list-style-type: none"> Detect a diagnostic on the valve module. See Table 6.2-24 for reference of the LED. Please check the Fieldbus module manual for details of the diagnosis. 	Please check the Fieldbus module manual for details of the diagnosis.
	<ul style="list-style-type: none"> Detect a diagnostic on the ITV module. See Table 6.2-24 for reference of the LED. Please check the Fieldbus module manual for details of the diagnosis. 	Please check the Fieldbus module manual for details of the diagnosis.

Table 6.2-24 Safety input process data and LED: ST Green and Red blinking

	Bit7	Bit6	Bit5	Bit4	Bit3	Bit2	Bit1	Bit0	LED	Status
Byte0	-	-	-	-	-	-	-	-	ST	Green/Red blinking
Byte1	-	-	-	-	-	-	-	-		
Byte2	-	-	-	-	-	-	-	-	FDI	-
Byte3	-	-	-	-	-	-	-	-		
Byte4	-	-	-	-	-	-	-	-	FDO	-
Byte5	-	-	-	-	-	-	-	-		
Byte6	-	-	-	-	-	-	-	-	INx	-
Byte7	-	-	-	-	-	-	-	-		
Byte8	-	-	-	-	-	-	-	-	Zx	-
Byte9	-	-	-	-	-	-	-	-		

6.2.1.9. Fault No.9

Table 6.2-25 ST Red ON

Fault No.	Possible cause	Action
9	<ul style="list-style-type: none"> Module may detect self-test error. Please power cycle again. If the problem persists after these countermeasures, please replace the module. See Table 6.2-26 for reference of the LED. 	<ul style="list-style-type: none"> Power cycle Replace the new safety IO module.

Table 6.2-26 Safety input process data LED: ST LED Red ON

	Bit7	Bit6	Bit5	Bit4	Bit3	Bit2	Bit1	Bit0	LED	Status
Byte0	-	-	-	-	-	-	-	-	ST	Red ON
Byte1	-	-	-	-	-	-	-	-		
Byte2	-	-	-	-	-	-	-	-	FDI	-
Byte3	-	-	-	-	-	-	-	-		
Byte4	-	-	-	-	-	-	-	-	FDO	-
Byte5	-	-	-	-	-	-	-	-		
Byte6	-	-	-	-	-	-	-	-	INx	-
Byte7	-	-	-	-	-	-	-	-		
Byte8	-	-	-	-	-	-	-	-	Zx	-
Byte9	-	-	-	-	-	-	-	-		

6.2.1.10. Fault No.10

Table 6.2-27 Other

Fault No.	Possible cause	Action
10	<ul style="list-style-type: none"> Module may detect self-test error. Please power cycle again. If the problem persists after these countermeasures, please replace the module. 	<ul style="list-style-type: none"> Power cycle Replace the new safety IO module.
	<ul style="list-style-type: none"> The module may already have TUNID set by another PLC. 	<ul style="list-style-type: none"> Safety reset Set TUNID again
	<ul style="list-style-type: none"> None of the others fault symptoms apply. 	Refer to the fieldbus or connection device manual for troubleshooting. If the problem persists, please try the following. <ul style="list-style-type: none"> Power cycle Replace the new safety IO module.

6.3. Safety integrity level with the system

! WARNING



This section provide the maximum achievable safety level for each application. However the achievable safety level depends on the user environment how to wiring and software configuring the module (e.g. The cable meet ISO13849 requirement, through implementation of channel comparison). The the overall safety level of the final equipment that using the Safety IO module should be calculated in your responsibility.

Table 6.3-1 Achievable safety level by each application example

Application example	SIL	PL
Single channel safety input (1oo1)	2	d
Single channel safety input with safety output (1oo1 + FDO)	2	d
Two singles channel safety input (1oo1 x 2)	3	e
Two singles channel safety input with safety output (1oo1 x 2 + FDO)	3	e
Two channel safety input (1oo2)	3	e
Two channel safety input with safety output (1oo2 + FDO)	3	e
Safety output	3	e

6.3.1. Safety inputs

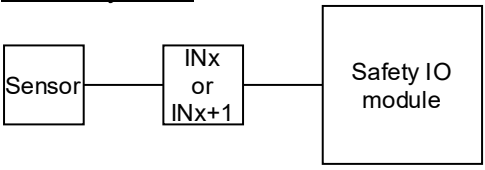
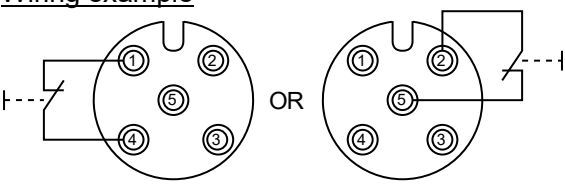
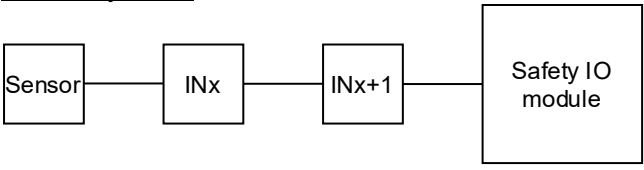
Table 6.3-2 Achievable safety level in Safety input function

Channel equivalent	Wiring example (CN0-7) and Reliability block	Clock pulse	Achievable safety level	
			SIL	PL
Single channel (1oo1) Device example <ul style="list-style-type: none"> • Reset switch • E-stop switch • Limit switch 	<u>Reliability block</u> 	Yes	2	d
	<u>Wiring example</u> 	No	2	d
Two single channel (1oo1 x 2) <ul style="list-style-type: none"> • Reset switch • E-stop switch • Limit switch • Two-hand switches • OSSD device 	<u>Reliability block</u> 	Yes	3*	e*
	<u>Wiring example</u> 			

Channel equivalent	Wiring example (CN0-7) and Reliability block	Clock pulse	Achievable safety level	
			SIL	PL
		No	2	d
	<p>Reliability block</p> <p>Wiring example</p>	No	3*	e*
Two channels equivalent (1oo2) Device example • E-stop switch • Limit switch • Two-hand switches • OSSD device	<p>Reliability block</p> <p>Wiring example</p>	Yes	3	e
	<p>Reliability block</p> <p>Wiring example</p>	No	3	e
	<p>Reliability block</p> <p>Wiring example</p>	No	3	e

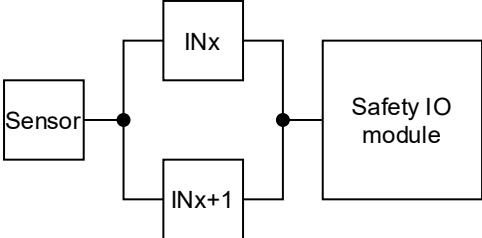
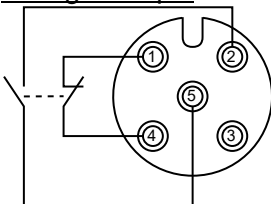
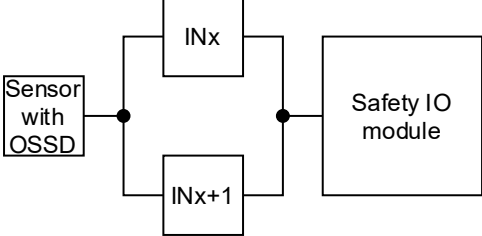
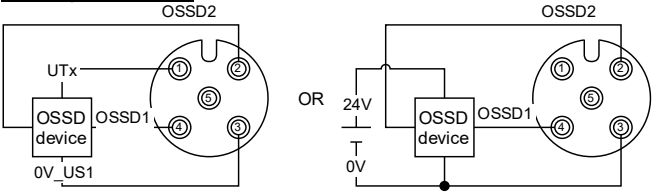
Channel equivalent	Wiring example (CN0-7) and Reliability block	Clock pulse	Achievable safety level	
			SIL	PL
Two channel equivalent (1oo2 Non-equivalent) Device example <ul style="list-style-type: none"> • E-stop switch • Limit switch • Two-hand switches • OSSD device 	Reliability block 	Yes	3	e
	Wiring example 	No	3	e
	Reliability block 	No	3	e
	Wiring example 			

*: Maximum achievable safety levels dependent on user software. For example, through implementation of channel comparison.

! WARNING

- The wiring is an example. Please re-calculate the safety level according to the actual usage environment, which is within your own responsibility.
- For applications where Clock pulse is disabled, please check the safety function at the diagnostic interval requested by the sensor at regular intervals (e.g. once a month, once a year).
- The connected device should be compliant with functional safety. It must have a safety level equal to or higher than the safety IO module. The sensor, connector and cable should meet the fault exclusion requirement of ISO 13849.

6.3.2. Safety outputs

Table 6.3-3 Achievable safety level in Safety output function

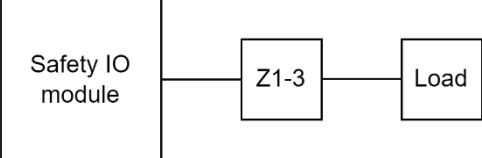
Application example	Wiring example (Z1-3) and Reliability block	Achievable safety level	
		SIL	PL
Device example • Valve • Relay	<u>Reliability block</u> 	3	e

⚠ WARNING

- The wiring is an example. Please re-calculate the safety level according to the actual usage environment, which is within your own responsibility.
- The connected device should be compliant with functional safety. It must have a safety level equal to or higher than the safety IO module. The sensor, connector and cable should meet the fault exclusion requirement of ISO 13849.

6.3.3. Safety input and Safety output

Table 6.3-4 Achievable safety level in safety input with safety output function

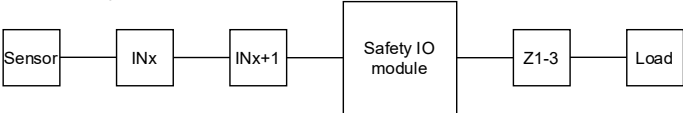
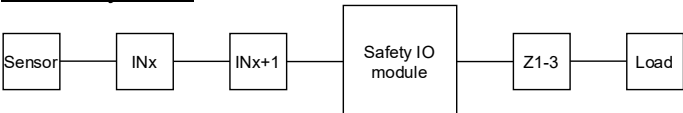
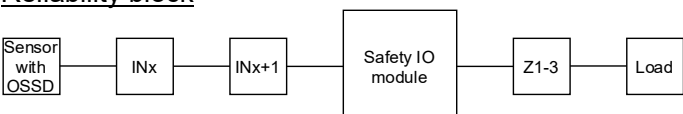
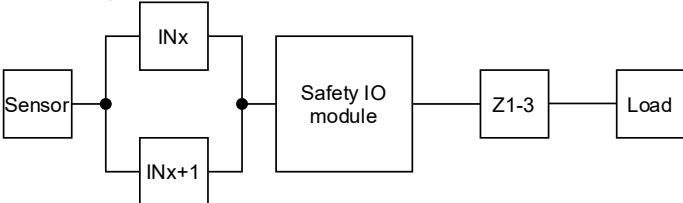
Channel equivalent	Reliability block	Clock pulse	Achievable safety level	
			SIL	PL
Single channel 1oo1 with safety output	<u>Reliability block</u> 	Yes	2	d
		No	2	d
Two singles channel 1oo1 with safety output	<u>Reliability block</u> 	Yes	3*	e*
		No	2	d
	<u>Reliability block</u> 	No	3	e
1oo2 Equivalent with safety output	<u>Reliability block</u> 	Yes	3	e
		No	3	e
	<u>Reliability block</u>	No	3	e

Channel equivalent	Reliability block	Clock pulse	Achievable safety level	
			SIL	PL
1oo2 Non-equivalent with safety output	<p><u>Reliability block</u></p>	Yes	3	e
		No	3	e

*: Maximum achievable safety levels dependent on user software. For example, through implementation of channel comparison.

WARNING	
<ul style="list-style-type: none"> • The wiring is an example. Please re-calculate the safety level according to the actual usage environment, which is within your own responsibility. • For applications where Clock pulse is disabled, please check the safety function at the diagnostic interval requested by the sensor at regular intervals (e.g. once a month, once a year). • The connected device should be compliant with functional safety. It must have a safety level equal to or higher than the safety IO module. The sensor, connector and cable should meet the fault exclusion requirement of ISO 13849. 	

6.4. Glossary

Table 6.4-1 Glossary

Initial	Items	Description
C	Clock pulse	A pulse is output to the sensor power supply to detect a cross circuit. This pulse calls Clock pulse in this manual.
	Cross circuit	A wiring fault where 2 signals are accidentally swapped e.g. UT1 and the other UT are incorrectly wired to the wrong inputs.
D	Discrepancy time	The difference time between the two signals in input
O	OSSD	An Output Signal Switching Device is a safety related output of a sensor that are self-checked.
S	Safety reset	Services provided by CIP safety. This service is used when restarting the Safety IO module, etc.
	Short circuit	Signal is either short circuited to another signal or 0V
	Stuck at	The output/input values are fixed to a certain logic which is not dependent on the control content.
T	TUNID	Services provided by CIP safety. Parameter for CIP safety that are generated based on SCCRC and SCTS etc., and are required when establishing a safe communication.

6.5. Accessories

See the Fieldbus module instruction manual for the detail.



Revision history
Revision 1: March 26 th , 2026 (Including the additional models)

SMC Corporation

Tel: + 81 3 5207 8249 Fax: +81 3 5298 5362
URL <https://www.smcworld.com>

Note: Specifications are subject to change without prior notice and any obligation on the part of the manufacturer.
© SMC Corporation All Rights Reserved
CIP Safety™ is a trademark of ODVA, Inc.

