



Operation Manual

PRODUCT NAME

Fieldbus system
Analog unit

MODEL / Series / Product Number

EX600-AXA
EX600-AYA
EX600-AMB

SMC Corporation

Table of Contents

Safety Instructions	3
System Outline	9
Assembly	10
Mounting and Installation	12
Installation	12
Wiring	14
Analog input unit	
Model Indication and How to Order	15
Names and Functions of Product	15
Mounting and Installation	16
Wiring	16
LED Display	18
Specification	19
Specifications	19
Dimensions	24
Analog output unit	
Model Indication and How to Order	25
Names and Functions of Product	25
Mounting and Installation	26
Wiring	26
LED Display	27
Specification	28
Specifications	28
Dimensions	32
Analog I/O unit	
Model Indication and How to Order	33
Names and Functions of Product	33
Mounting and Installation	34
Wiring	34
LED Display	36
Specification	37
Specifications	37
Dimensions	44

Common items

Maintenance	45
Troubleshooting	46
Parameter Setting	46
I/O Map	46
Diagnostic	46
Accessories	46
Precautions before mounting	47



Safety Instructions

These safety instructions are intended to prevent hazardous situations and/or equipment damage. These instructions indicate the level of potential hazard with the labels of “**Caution**,” “**Warning**” or “**Danger**.” They are all important notes for safety and must be followed in addition to International Standards (ISO/IEC)^{*)}, and other safety regulations.

*) ISO 4414: Pneumatic fluid power - General rules and safety requirements for systems and their components
ISO 4413: Hydraulic fluid power - General rules and safety requirements for systems and their components
IEC 60204-1: Safety of machinery - Electrical equipment of machines - Part 1: General requirements
ISO 10218-1: Robots and robotic devices - Safety requirements for industrial robots - Part 1: Robots
etc.



Danger

Danger indicates a hazard with a high level of risk which, if not avoided, will result in death or serious injury.



Warning

Warning indicates a hazard with a medium level of risk which, if not avoided, could result in death or serious injury.



Caution

Caution indicates a hazard with a low level of risk which, if not avoided, could result in minor or moderate injury.



Warning

1. The compatibility of the product is the responsibility of the person who designs the equipment or decides its specifications.

Since the product specified here is used under various operating conditions, its compatibility with specific equipment must be decided by the person who designs the equipment or decides its specifications based on necessary analysis and test results. The expected performance and safety assurance of the equipment will be the responsibility of the person who has determined its compatibility with the product. This person should also continuously review all specifications of the product referring to its latest catalog information, with a view to giving due consideration to any possibility of equipment failure when configuring the equipment.

2. Only personnel with appropriate training should operate machinery and equipment.

The product specified here may become unsafe if handled incorrectly. The assembly, operation and maintenance of machines or equipment including our products must be performed by an operator who is appropriately trained and experienced.

3. Do not service or attempt to remove product and machinery/equipment until safety is confirmed.

1. The inspection and maintenance of machinery/equipment should only be performed after measures to prevent falling or runaway of the driven objects have been confirmed.
2. When the product is to be removed, confirm that the safety measures as mentioned above are implemented and the power from any appropriate source is cut, and read and understand the specific product precautions of all relevant products carefully.
3. Before machinery/equipment is restarted, take measures to prevent unexpected operation and malfunction.

4. Our products cannot be used beyond their specifications. Our products are not developed, designed, and manufactured to be used under the following conditions or environments. Use under such conditions or environments is not covered.

1. Conditions and environments outside of the given specifications, or use outdoors or in a place exposed to direct sunlight.
2. Use for nuclear power, railways, aviation, space equipment, ships, vehicles, military application, equipment affecting human life, body, and property, fuel equipment, entertainment equipment, emergency shut-off circuits, press clutches, brake circuits, safety equipment, etc., and use for applications that do not conform to standard specifications such as catalogs and operation manuals.
3. Use for interlock circuits, except for use with double interlock such as installing a mechanical protection function in case of failure. Please periodically inspect the product to confirm that the product is operating properly.



Safety Instructions

Caution

We develop, design, and manufacture our products to be used for automatic control equipment, and provide them for peaceful use in manufacturing industries. Use in non-manufacturing industries is not covered.

Products we manufacture and sell cannot be used for the purpose of transactions or certification specified in the Measurement Act.

The new Measurement Act prohibits use of any unit other than SI units in Japan.

Limited warranty and Disclaimer/Compliance Requirements

The product used is subject to the following “Limited warranty and Disclaimer” and “Compliance Requirements”.

Read and accept them before using the product.

Limited warranty and Disclaimer

1. The warranty period of the product is 1 year in service or 1.5 years after the product is delivered, whichever is first.*2)
Also, the product may have specified durability, running distance or replacement parts. Please consult your nearest sales branch.
2. For any failure or damage reported within the warranty period which is clearly our responsibility, a replacement product or necessary parts will be provided.
This limited warranty applies only to our product independently, and not to any other damage incurred due to the failure of the product.
3. Prior to using SMC products, please read and understand the warranty terms and disclaimers noted in the specified catalog for the particular products.

***2) Vacuum pads are excluded from this 1 year warranty.**

A vacuum pad is a consumable part, so it is warranted for a year after it is delivered.

Also, even within the warranty period, the wear of a product due to the use of the vacuum pad or failure due to the deterioration of rubber material are not covered by the limited warranty

Compliance Requirements

1. The use of SMC products with production equipment for the manufacture of weapons of mass destruction (WMD) or any other weapon is strictly prohibited.
2. The exports of SMC products or technology from one country to another are governed by the relevant security laws and regulations of the countries involved in the transaction. Prior to the shipment of a SMC product to another country, assure that all local rules governing that export are known and followed.

Operator

- ◆ This operation manual is intended for those who have knowledge of machinery using pneumatic equipment, and have sufficient knowledge of assembly, operation and maintenance of such equipment. Only those persons are allowed to perform assembly, operation and maintenance.
- ◆ Read and understand this operation manual carefully before assembling, operating or providing maintenance to the product.

■ Safety Instructions

Warning

- Do not disassemble, modify (including changing the printed circuit board) or repair.
An injury or failure can result.
- Do not operate or set with wet hands.
This may lead to an electric shock.
- Do not operate the product outside of the specifications.
Do not use for flammable or harmful fluids.
Fire, malfunction, or damage to the product can result.
Verify the specifications before use.
- Do not operate in an atmosphere containing flammable or explosive gases.
Fire or an explosion can result.
This product is not designed to be explosion proof.
- If using the product in an interlocking circuit:
 - Provide a double interlocking system, for example a mechanical system.
 - Check the product regularly for proper operation.Otherwise malfunction can result, causing an accident.
- The following instructions must be followed during maintenance:
 - Turn off the power supply.
 - Stop the air supply, exhaust the residual pressure and verify that the air is released before performing maintenance.Otherwise an injury can result.

Caution

- When handling the unit or assembling/replacing units:
 - Do not touch the sharp metal parts of the connector or plug for connecting units.
 - Take care not to hit your hand when disassembling the unit.
The connecting portions of the unit are firmly joined with seals.
 - When joining units, take care not to get fingers caught between units.
An injury can result.
- After maintenance is complete, perform appropriate functional inspections.
Stop operation if the equipment does not function properly.
Safety cannot be assured in the case of unexpected malfunction.
- Provide grounding to assure the safety and noise resistance of the Fieldbus system.
Individual grounding should be provided close to the product with a short cable.

■ NOTE

- Follow the instructions given below when designing, selecting and handling the product.
- The instructions on design and selection (installation, wiring, environment, adjustment, operation, maintenance, etc.) described below must also be followed.
 - *Product specifications
 - The direct current power supply to combine should be UL 1310 Class2 power supply when conformity to UL is necessary.
 - Use the specified voltage.
Otherwise failure or malfunction can result.
 - The power supply for the unit should be 0V as the standard for both the power supply for outputs and the power supply for inputs and control.

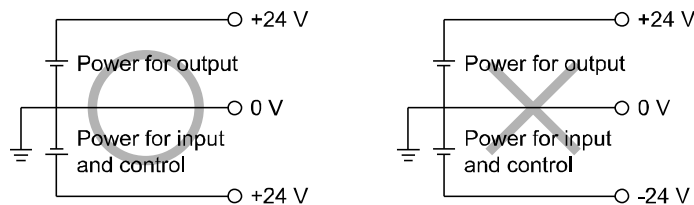

- Reserve a space for maintenance.
Allow sufficient space for maintenance when designing the system.
- Do not remove any nameplates or labels.
This can lead to incorrect maintenance, or misreading of the operation manual, which could cause damage or malfunction to the product.
It may also result in non-conformity to safety standards.
- Beware of inrush current when the power supply is turned on.
Some connected loads can apply an initial charge current which will activate the over current protection function, causing the unit to malfunction.

●Product handling

*Installation

- Do not drop, hit or apply excessive shock to the SI unit.
Otherwise damage to the product can result, causing malfunction.
- Tighten to the specified tightening torque.
If the tightening torque is exceeded the mounting screws may be broken.
IP67 protection cannot be guaranteed if the screws are not tightened to the specified torque.
- If a large manifold valve is mounted, lift the unit so that stress is not applied to the connecting part while transporting.
The stress may cause breakage of the connecting part. The unit may become very heavy depending on the combination. Transportation/installation shall be performed by multiple operators.
- Never mount a product in a location that will be used as a foothold.
The product may be damaged if excessive force is applied by stepping or climbing onto it.

*Wiring

- Avoid repeatedly bending or stretching the cables, or placing heavy load on them.
Repetitive bending stress or tensile stress can cause breakage of the cable.
- Wire correctly.
Incorrect wiring can break the product.
- Do not perform wiring while the power is on.
Otherwise damage to the SI unit and/or input or output device can result, causing malfunction.
- Do not route wires and cables together with power or high voltage cables.
Otherwise the SI unit and/or input or output device can malfunction due to interference of noise and surge voltage from power and high voltage cables to the signal line.
Route the wires (piping) of the SI unit and/or input or output device separately from power or high voltage cables.
- Confirm proper insulation of wiring.
Poor insulation (interference from another circuit, poor insulation between terminals, etc.) can lead to excess voltage or current being applied to the product, causing damage.
- Take appropriate measures against noise, such as using a noise filter, when the Fieldbus system is incorporated into equipment.
Otherwise noise can cause malfunction.

*Environment

- Select the proper type of protection according to the environment of operation.
IP67 protection is achieved when the following conditions are met.
 - (1)The units are connected properly with fieldbus cable with M12 connector and power cable with M12 (M8) connector.
 - (2)Suitable mounting of each unit and manifold valve.
 - (3)Be sure to fit a waterproof cap on any unused connectors.
If using in an environment that is exposed to water splashes, please take measures such as using a cover.
Do not use in an environment where moisture or water vapor are present. Otherwise failure and malfunction can result.
- Do not use in a place where the product could be splashed by oil or chemicals.
If the product is to be used in an environment containing oils or chemicals such as coolant or cleaning solvent, even for a short time, it may be adversely affected (damage, malfunction etc.).
- Do not use the product in an environment where corrosive gases or fluids could be splashed.
Otherwise damage to the product and malfunction can result.
- Do not use in an area where surges are generated.
If there is equipment generating large surge near the unit (magnetic type lifter, high frequency inductive furnace, welding machine, motor, etc.), this can cause deterioration of the internal circuitry element of the unit or result in damage. Take measures against the surge sources, and prevent the lines from coming into close contact.

- When a surge-generating load such as a relay, valve or lamp is driven directly, use a product with a built-in surge absorbing element.
Direct drive of a load generating surge voltage can damage the unit.
- The product is CE/UKCA marked, but not immune to lightning strikes. Take measures against lightning strikes in the system.
- Prevent foreign matter such as dust or wire debris from getting inside the product.
- Mount the product in a place that is not exposed to vibration or impact.
Otherwise failure or malfunction can result.
- Do not use the product in an environment that is exposed to temperature cycle.
Heat cycles other than ordinary changes in temperature can adversely affect the inside of the product.
- Do not expose the product to direct sunlight.
If using in a location directly exposed to sunlight, shade the product from the sunlight.
Otherwise failure or malfunction can result.
- Keep within the specified ambient temperature range.
Otherwise malfunction can result.
- Do not operate close to a heat source, or in a location exposed to radiant heat.
Otherwise malfunction can result.

***Adjustment and Operation**

- Set the switches by using a sharp-pointed screwdriver etc. When setting the switch, do not touch other unrelated parts.
This can cause parts damage or malfunction due to a short circuit.
- Perform settings suitable for the operating conditions.
Incorrect setting can cause operation failure.
For details of each setting, refer to the SI unit Operation Manual.
- Please refer to the PLC manufacturer's manual etc. for details of programming and addresses.
For the PLC protocol and programming refer to the relevant manufacturer's documentation.

***Maintenance**

- Turn off the power supply, stop the supplied air, exhaust the residual pressure and verify the release of air before performing maintenance.
There is a risk of unexpected malfunction.
- Perform regular maintenance and inspections.
There is a risk of unexpected malfunction.
- After maintenance is complete, perform appropriate functional inspections.
Stop operation if the equipment does not function properly.
Otherwise safety is not assured due to an unexpected malfunction or incorrect operation.
- Do not use solvents such as benzene, thinner etc. to clean each unit.
They could damage the surface of the body and erase the markings on the body.
Use a soft cloth to remove stains.
For heavy stains, use a cloth soaked with diluted neutral detergent and fully squeezed, then wipe up the stains again with a dry cloth.

System Outline

•System configuration

The EX600 range of units can be connected to various types of Fieldbus to realize the reduction of input or output device wiring and the distributed control system. The unit communicates with the Fieldbus through the SI unit. One SI unit can be connected with manifold valves with up to 32 outputs and the input • output • I/O units with maximum 10 units.

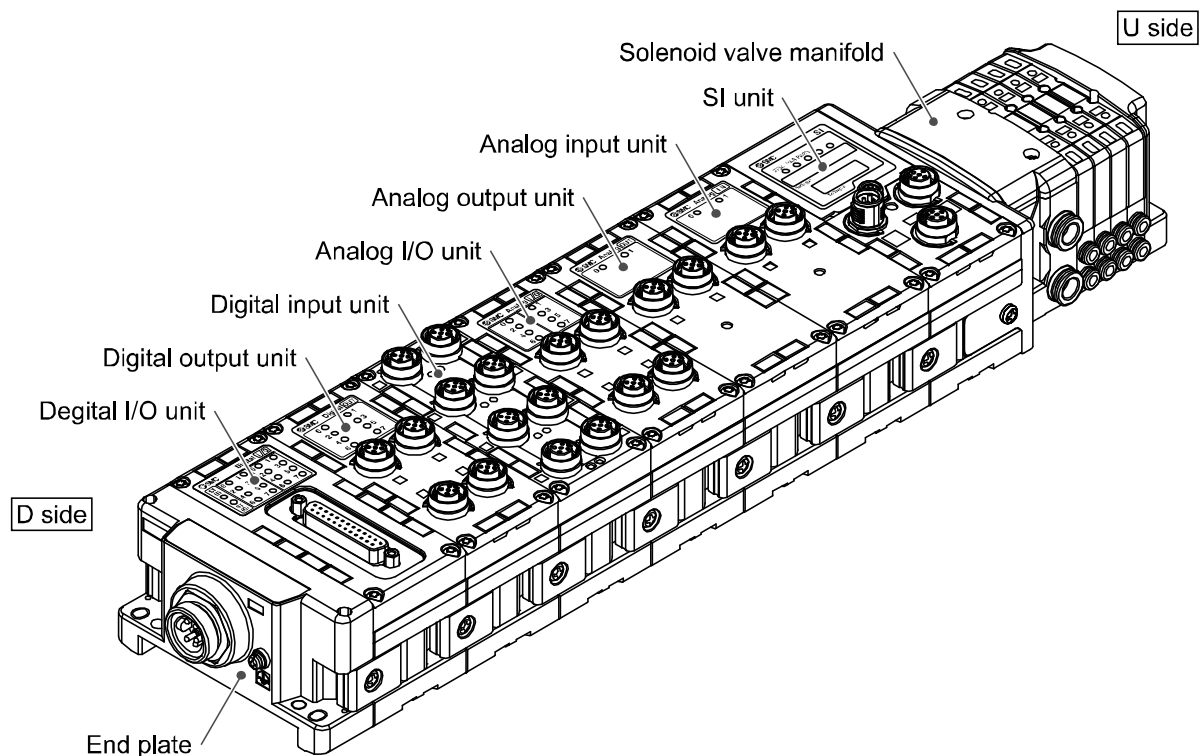

SI unit: Performs Fieldbus communication and solenoid valve manifold ON/OFF output.

Digital input unit: For connecting sensors with switch output capability. PNP and NPN types are available.

Digital output unit: For connecting output device such as solenoid valves, lamps, buzzers, etc. PNP and NPN types are available.

Digital I/O unit: This unit has both digital input and output functions. PNP and NPN types are available.

Analog input unit: For connecting sensors with analog output capability.

Analog output unit: This can be connected to the equipment which can read analog input.

Analog I/O unit: This unit has both analog input and output functions.

End plate: Connected at EX600 Manifold's D side, incorporating the power supply connection.

Solenoid valve manifold: An assembly of solenoid valves. One connector is used as the electric connection to all connected valves.

Assembly

•Composing the unit as a manifold

*: If the unit was purchased as a manifold, the work described in this section is not necessary.

(1)Connect the unit to the end plate.

The Digital unit, Analog unit can be connected in any order.

Tighten the bracket of the joint using tightening torque 1.5 to 1.6 Nm.

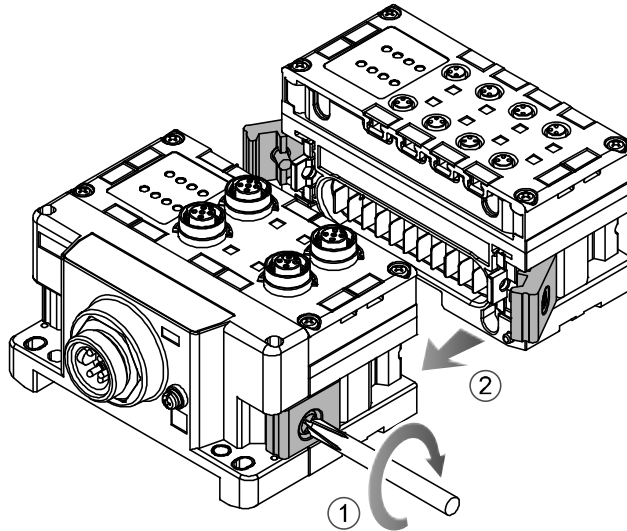

(2)Add more units.

Up to 10 units (including the SI unit) can be connected to one manifold.

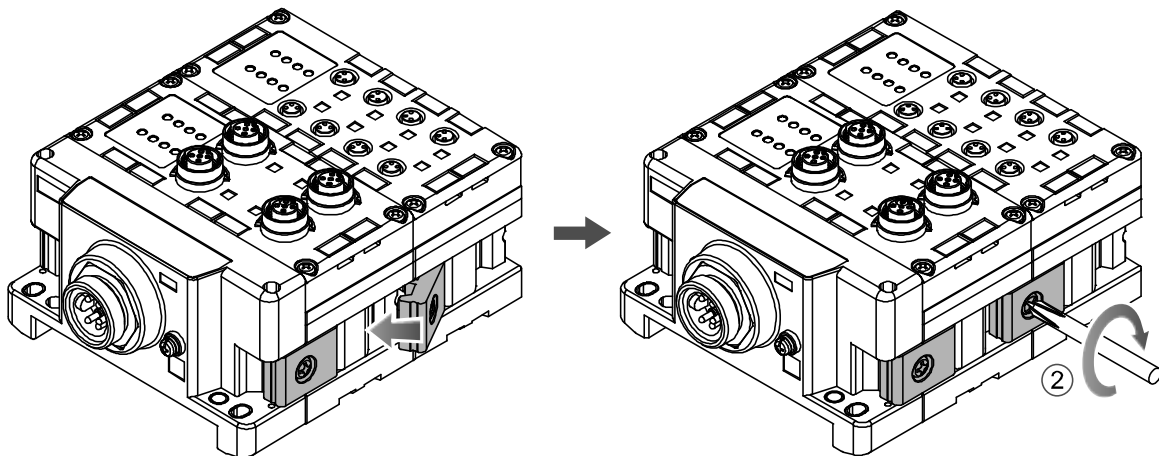

(3)Connecting the SI unit.

After connecting the necessary units, connect the SI unit.

Connecting method is the same as above (1), (2).

(4) Mounting the valve plate.

Mount the valve plate (EX600-ZMV□) to the valve manifold using the valve set screws. (M3x8)
Apply 0.6 to 0.7 Nm tightening torque to the screws.

Screw mounting place	
SV	: 2 places
S0700	: 2 places
VQC1000	: 2 places
VQC2000	: 3 places
VQC4000	: 4 places
SY	: 2 places

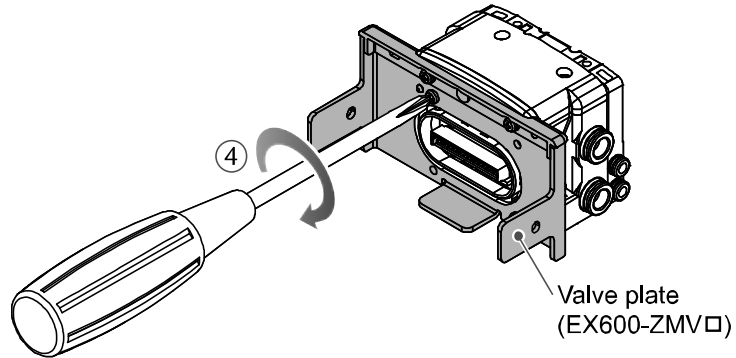

(5) Connect the SI unit and the valve manifold.

Insert the valve plate to the valve plate set groove on the side of SI unit.
Then, tighten it with the valve plate set screws (M4x6) to fix the plate.
Tightening torque for set screws 0.7 to 0.8 Nm.

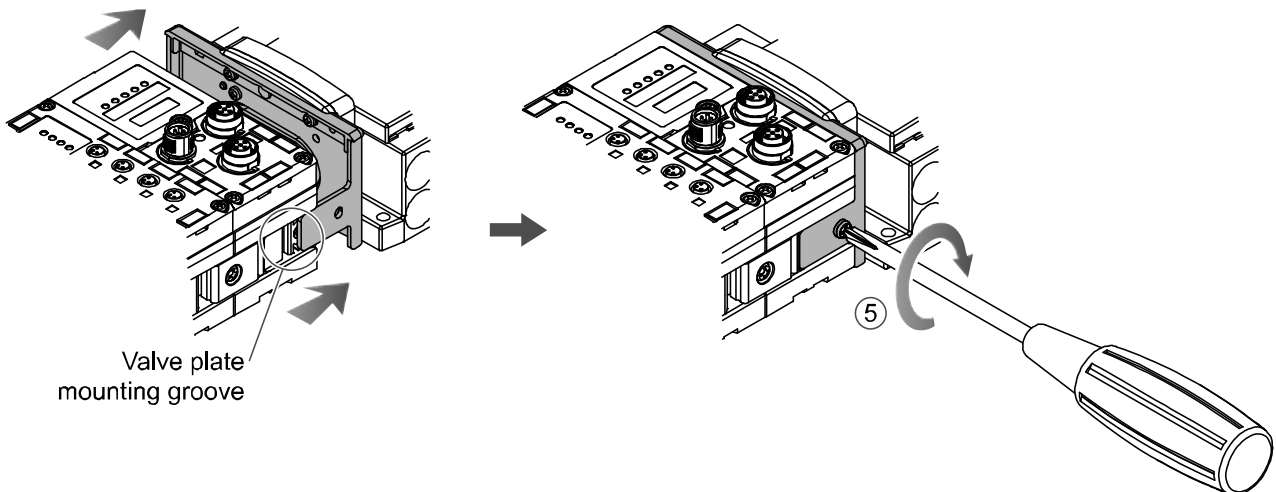

● Precautions for handling

- Please do not connect the unit while the power supply is active. It will cause equipment damage.
- Take care not to drop the nuts of Joint bracket.

Mounting and Installation

■ Installation

• Direct mounting

(1) When joining six or more units, fix the middle part of the complete EX600 unit with an intermediate reinforcing brace (EX600-ZMB1) before mounting using 2-M4x5 screws.

Tightening torque: 0.7 to 0.8 Nm.

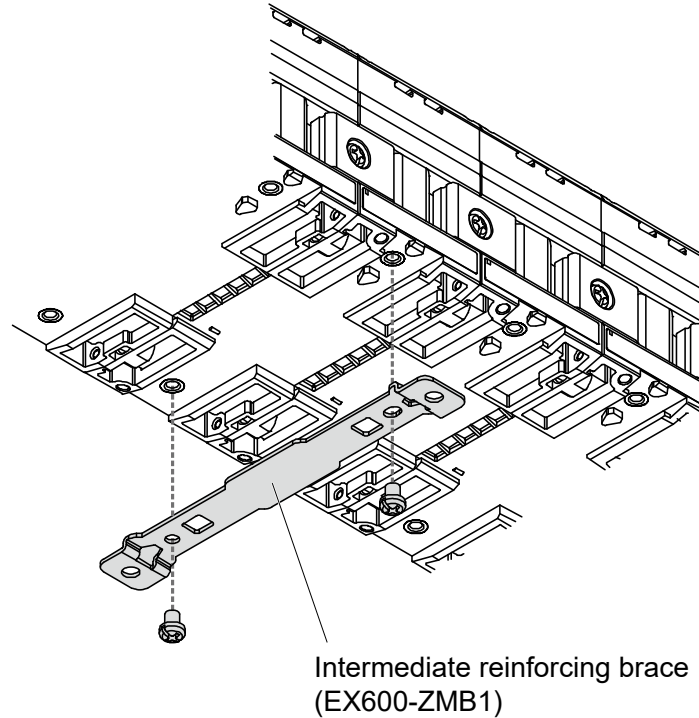

(2) Fix and tighten the end plates at one end of the unit. (M4)

Tightening torque: 0.7 to 0.8 Nm.

Fix the end plate at the valve side while referring to the operation manual of the corresponding valve manifold.

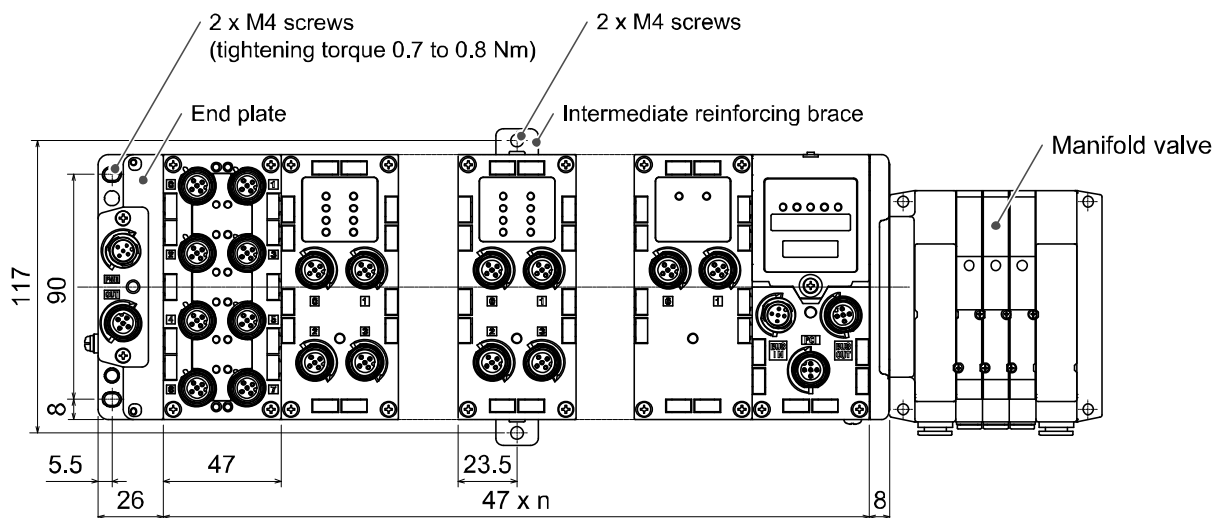

n (Number of connected units) ≤ 10

•DIN rail mounting

(Available for series other than SY series. Refer to the catalog for SY series.)

(1)When joining six or more units, fix the middle part of the complete EX600 unit with an intermediate reinforcing brace (EX600-ZMB2) before mounting, using 2-M4x6 screws.

Tightening torque: 0.7 to 0.8 Nm.

(2)Mount the end plate bracket (EX600-ZMA2) to the end plate at the opposite end to the valves, using 2-M4x14 screws.

Tightening torque: 0.7 to 0.8 Nm.

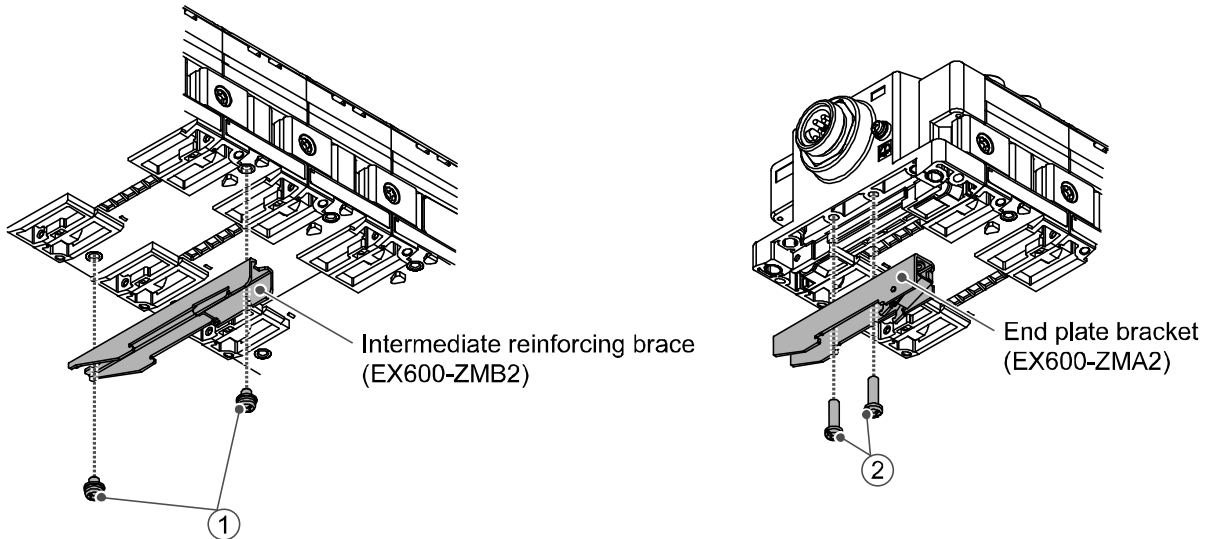

(3)Hook the DIN rail mounting groove to the DIN rail.

(4)Press the manifold using its side hooked to the DIN rail as a fulcrum until the manifold is locked.

(5)Fix the manifold by tightening the DIN rail fixing screws of the EX600-ZMA2. (M4x20)

Tightening torque: 0.7 to 0.8 Nm.

The tightening torque at the valve side depends on the valve type.

Refer to the operation manual of the corresponding valve manifold.

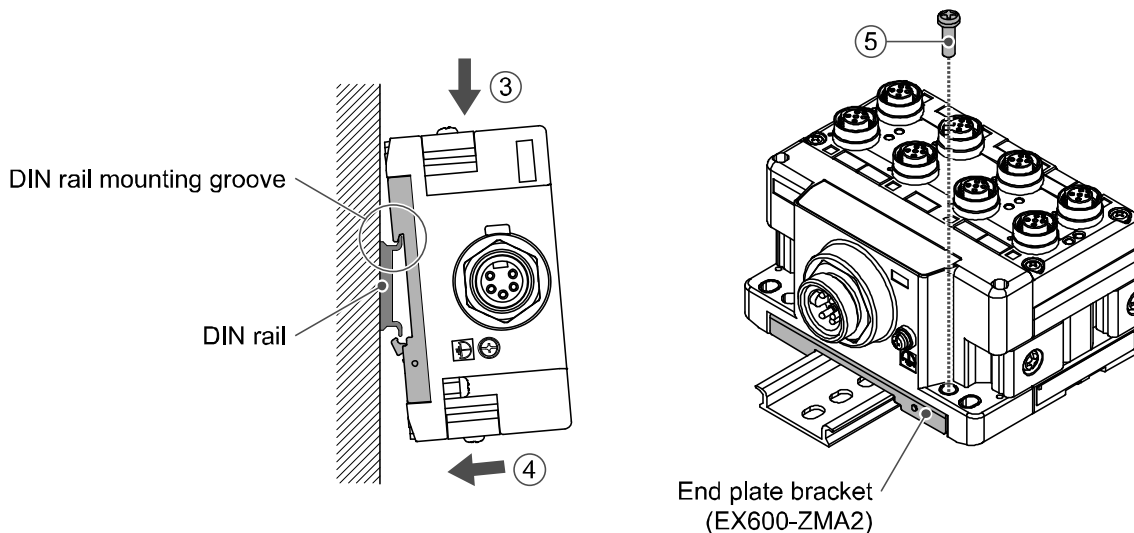

■Wiring

•Connect the M12 or M8 connector cable. M12 connector is applicable for SPEEDCON connector. SPEEDCON connector wiring method is explained below.

(1)Align the mark B on the metal bracket of the cable side connector (plug/socket) with the mark A.

(2)Align the mark C on the unit and insert the connector into the unit vertically.

If they are not aligned, the connector cannot be joined properly.

(3)When the mark B of the connector has been turned 180 degrees (1/2 turn), wiring is completed. Confirm that the connection is not loose. If turned too far, it will become hard to remove the connector.

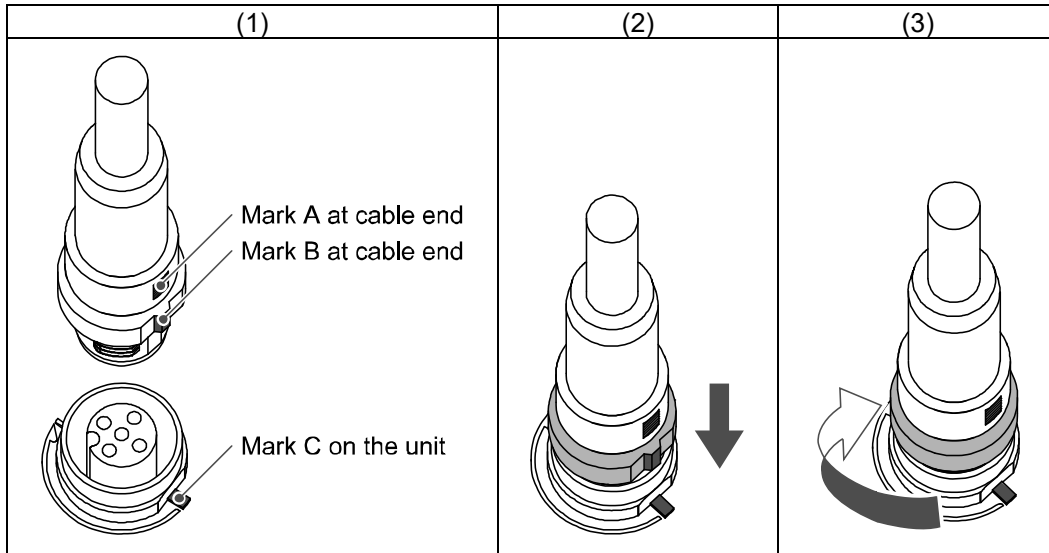

•Mounting the marker

Signal name of the input or output devices and unit address can be written to the marker, and it can be installed to each unit.

Mount the marker (EX600-ZT1) into the marker groove as required.

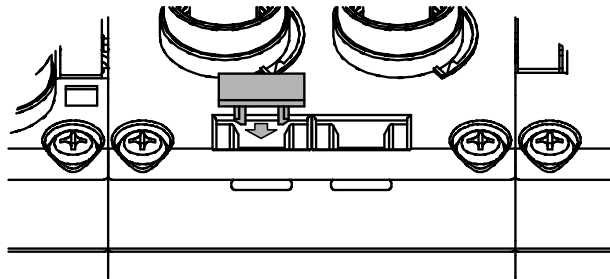

Analog input unit

Model Indication and How to Order

EX600-AX□

Analog input

Connector and number of input channels

Symbol	Connector	Number of input channels
A	2xM12 connector (5 pin) *	2 channels

*: An M12 connector (4 pin) can also be connected.

Names and Functions of Product

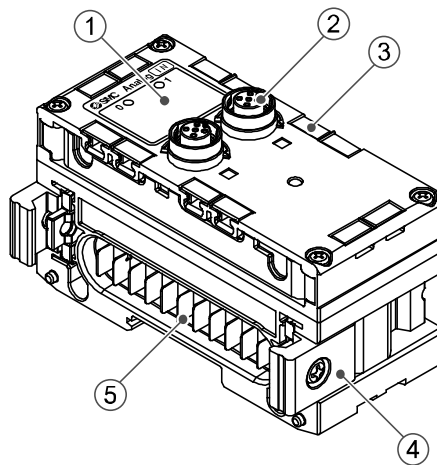

No.	Description	Function
1	Status display LED	Displays the status of the unit.
2	Connector (Analog input)	Connector for analog input device.
3	Marker groove	Groove to mount a marker.
4	Joint bracket	Bracket for joining to adjacent units.
5	Unit Connector (Plug)	Transmits signals and power supplies to adjacent units.

Mounting and Installation

■Wiring

○Connector pin assignment and circuit diagram

•Connector pin assignment

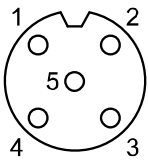
Configuration	Pin number	Signal name
	1	24 V (Control and input)
	2	Input +
	3	0 V (Control and input)
	4	Input -
	5	FE

*: An M12 connector (4 pin) can also be connected.

•Circuit diagram

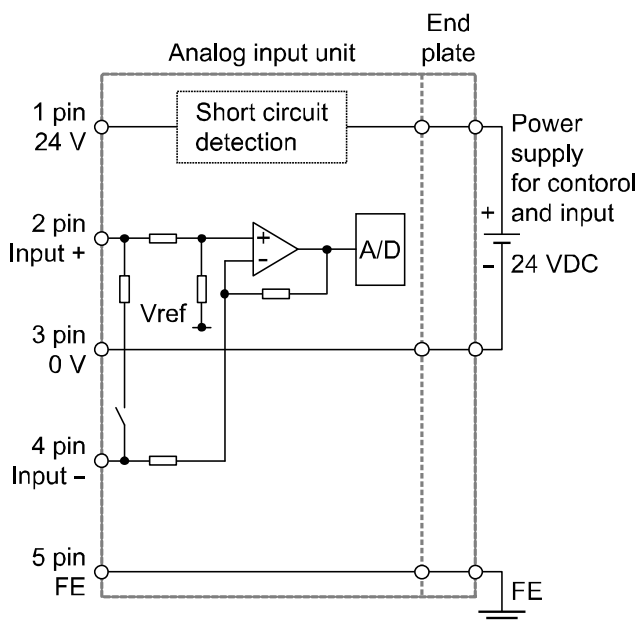

Input impedance

Voltage input: 100 k Ω

Current input: 50 Ω

●Precautions for handling

Be sure to fit a seal cap on any unused connectors. Proper use of the seal cap enables the enclosure to achieve IP67 specification.

○ Examples of wiring with input devices

- When using a sensor whose analog output signal is 0 V standard type.

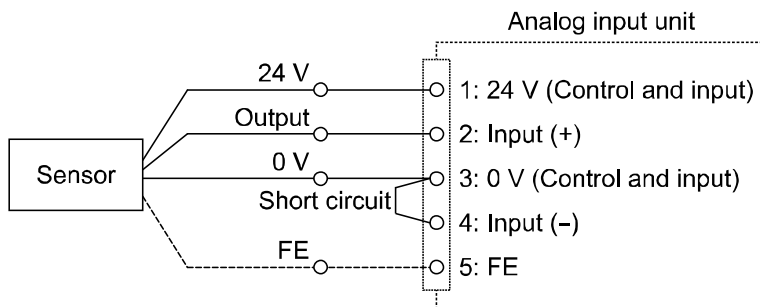

- When using a 2-wire current output type sensor.

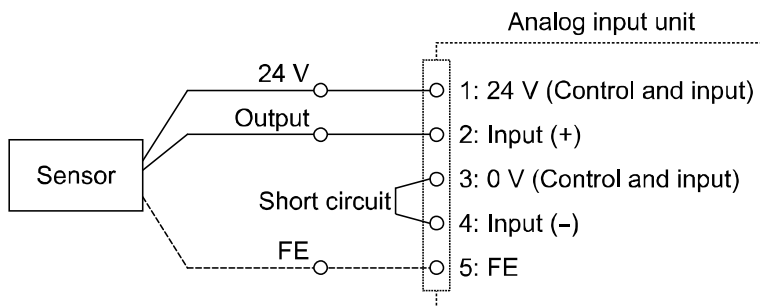

- When using a differential output type sensor.

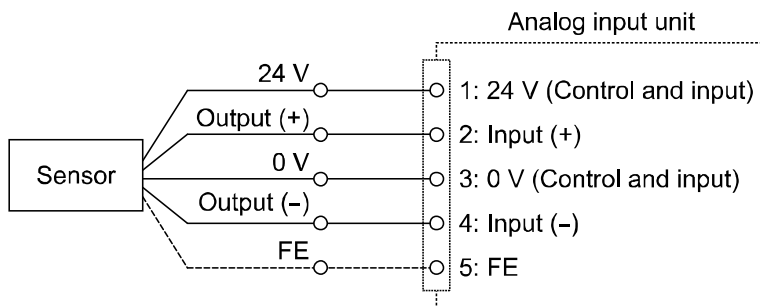

● Precautions for handling

When an analog sensor is connected to the Analog input unit, pay attention to the following cautions.

EX600 analog input has a differential input specification, and it receives 2-pin (input +) signal based on 4-pin (input -). Because of the specification, if 4-pin is not connected, it will not be able to read the signal input properly. Therefore, when using an analog sensor that does not have the differential output type, 3-pin and 4-pin should be connected externally.

LED Display

The status display LED shows following unit status.
Various kinds of status can be checked as follows:

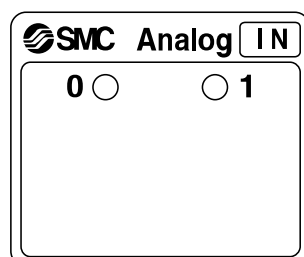

Display	Content
○ OFF	The power supply for control and input is OFF.
● Green LED is ON	The product is operating normally.
● Red LED is ON	The power supply of input device has a short circuit.
● ● 0 and 1 red LEDs are ON	Either of the following conditions: <ul style="list-style-type: none"> •The current value of the analog input device has exceeded the upper or lower limit. •When the range is set by current input type, voltage is input from the analog input device.
⊙ Red LED is flashing	Either of the following conditions: <ul style="list-style-type: none"> •The upper or lower limit of the range is exceeded. •The upper or lower limit of the measuring value (With user's setting value) is exceeded.

*: Refer to troubleshooting (SI unit Operation Manual of protocol used) for the further details of countermeasures.

Specification

■ Specifications

Model		EX600-AXA		
Input specifications	Input type	Voltage input type	Current input type	
	Input connector	M12 connector (5 pin) Socket *1		
	Number of input channels	2 channels (1 channel/Connector)		
	Power supply voltage (Control and input)	24 VDC Class2, 2 A		
	Max. sensor supply current	0.5 A/Channel		
	Protective function	Short circuit protection		
	Input signal range	12 bit Resolution	0 to 10 V, 1 to 5 V, 0 to 5 V	0 to 20 mA, 4 to 20 mA
		16 bit Resolution	-10 to 10 V, -5 to 5 V	-20 to 20 mA
	Max. rated input signal	±15 V	±40 mA	
	Input impedance	100 kΩ	50 Ω	
	Linearity (25 °C)	±0.05%F.S or less		
	Repeatability (25 °C)	±0.15%F.S. or less		
	Absolute accuracy (25 °C)	±0.5%F.S. or less	±0.6%F.S. or less	
	Current consumption	70 mA or less		
Environment	Enclosure	IP67 (With manifold assembled) *2		
	Operating temperature range	-10 to 50 °C (Max. surrounding air temperature rating: 50 °C) *3		
	Storage temperature range	-20 to 60 °C		
	Operating humidity range	35 to 85%RH (No condensation)		
	Withstand voltage	500 VAC for 1 min. between external terminals and FE		
	Insulation resistance	500 VDC, 10 MΩ or more between external terminals and FE		
	Pollution degree	For use in Pollution Degree 3 Environment (UL508)		
Standard	CE/UKCA marked, UL (CSA)			
Weight	290 g			

*1: An M12 connector (4 pin) can also be connected.

*2: All unused connectors must have a seal cap fitted.

*3: The UL compliant temperature is 0 to 50 °C.

○Analog input characteristics

(1)Offset binary data format

•Input signal range: 0 to 10 V, 0 to 5 V, 0 to 20 mA

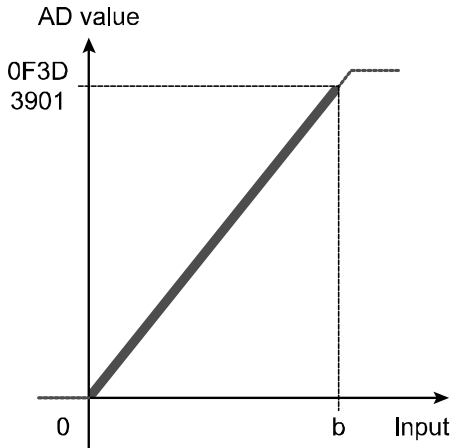

AD value		Input signal range (0 to b)		
Hexadecimal number	Decimal number	Voltage [V]		Current [mA]
		0 to 10 V	0 to 5 V	0 to 20 mA
0FFF	4095	10.5	5.25	21
0F3D	3901	10	5	20
0800	2048	5.25	2.625	10.5
0000	0	0	0	0

•Input signal range: 1 to 5 V, 4 to 20 mA

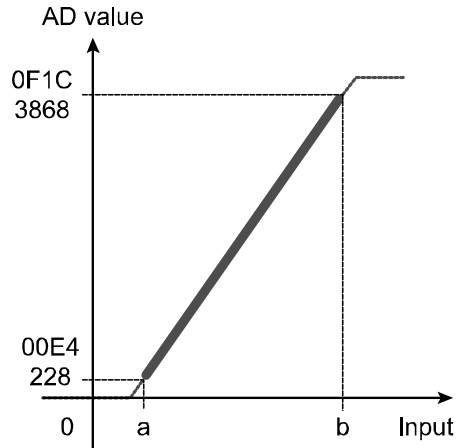

AD value		Input signal range (a to b)		
Hexadecimal number	Decimal number	Voltage [V]		Current [mA]
		1 to 5 V	4 to 20 mA	
0FFF	4095	5.25	21	
0F1C	3868	5	20	
0800	2048	3	12	
00E4	228	1	4	
0000	0	0.75	3	

•Data format

		Byte0								Byte1							
CH0		15	14	13	12	11	10	9	8	7	6	5	4	3	2	1	0
		0	0	0	0	MSB				AD value							
		Byte2								Byte3							
CH1		15	14	13	12	11	10	9	8	7	6	5	4	3	2	1	0
		0	0	0	0	MSB				AD value							

- Input signal range: -10 to 10 V, -5 to 5 V, -20 to 20 mA

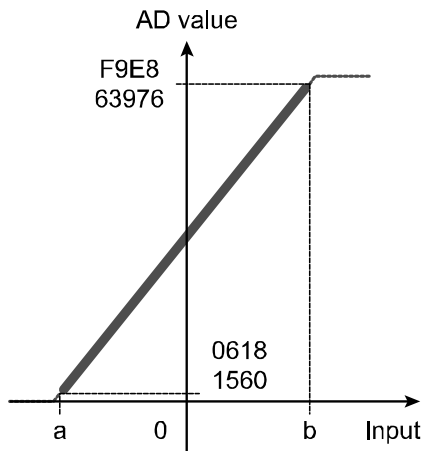

AD value		Input signal range (a to b)		
Hexadecimal number	Decimal number	Voltage [V]		Current [mA]
		-10 to 10 V	-5 to 5 V	-20 to 20 mA
FFFF	65535	10.5	5.25	21
F9E8	63976	10	5	20
BCF4	48372	5	2.5	10
8000	32768	0	0	0
430C	17164	-5	-2.5	-10
0618	1560	-10	-5	-20
0000	0	-10.5	-5.25	-21

- Data format

		Byte0								Byte1							
CH0		15	14	13	12	11	10	9	8	7	6	5	4	3	2	1	0
		MSB AD value LSB															
		Byte2								Byte3							
CH1		15	14	13	12	11	10	9	8	7	6	5	4	3	2	1	0
		MSB AD value LSB															

(2) Signed binary data format and two's complement data format

•Input signal range: 0 to 10 V, 0 to 5 V, 0 to 20 mA

•Input signal range: 1 to 5 V, 4 to 20 mA

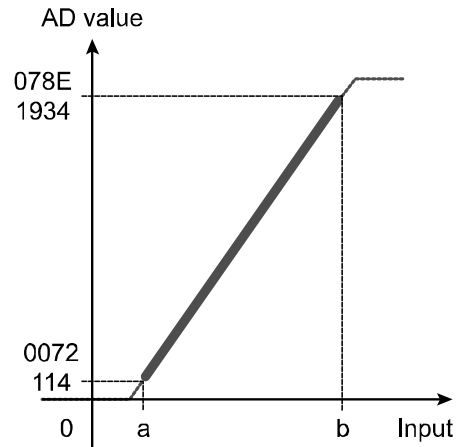
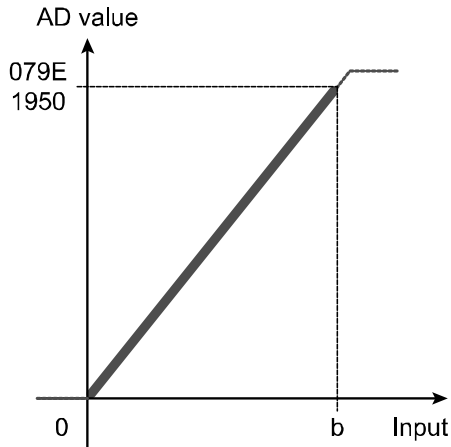

AD value		Input signal range (0 to b)		
Hexadecimal number	Decimal number	Voltage [V]		Current [mA]
		0 to 10 V	0 to 5 V	0 to 20 mA
07FF	2047	10.5	5.25	21
079E	1950	10	5	20
0400	1024	5.25	2.625	10.5
0000	0	0	0	0

AD value		Input signal range (a to b)		
Hexadecimal number	Decimal number	Voltage [V]		Current [mA]
		1 to 5 V	4 to 20 mA	
07FF	2047	5.25	21	
078E	1934	5	20	
0400	1024	3	12	
0072	114	1	4	
0000	0	0.75	3	

•Data format

		Byte0								Byte1							
CH0		15	14	13	12	11	10	9	8	7	6	5	4	3	2	1	0
		0	0	0	0	Sign	MSB			AD value							
		Byte2								Byte3							
CH1		15	14	13	12	11	10	9	8	7	6	5	4	3	2	1	0
		0	0	0	0	Sign	MSB			AD value							

•Input signal range : -10 to 10 V, -5 to 5 V, -20 to 20 mA

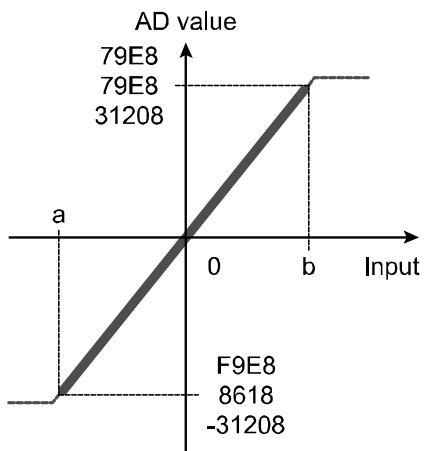

AD value			Input signal range (a to b)		
Hexadecimal number (Signed binary format)	Hexadecimal number (Two's complement format)	Decimal number	Voltage [V]		Current [mA]
			-10 to 10 V	-5 to 5 V	-20 to 20 mA
7FFF	7FFF	32767	10.5	5.25	21
79E8	79E8	31208	10	5	20
3CF4	3CF4	15604	5	2.5	10
0000	0000	0	0	0	0
BCF4	C30C	-15604	-5	-2.5	-10
F9E8	8618	-31208	-10	-5	-20
FFFF	8000	-32767	-10.5	-5.25	-21

•Data format

		Byte0								Byte1							
CH0		15	14	13	12	11	10	9	8	7	6	5	4	3	2	1	0
	Sign	MSB								AD value							
		Byte2								Byte3							
CH1		15	14	13	12	11	10	9	8	7	6	5	4	3	2	1	0
	Sign	MSB								AD value							

■Dimensions

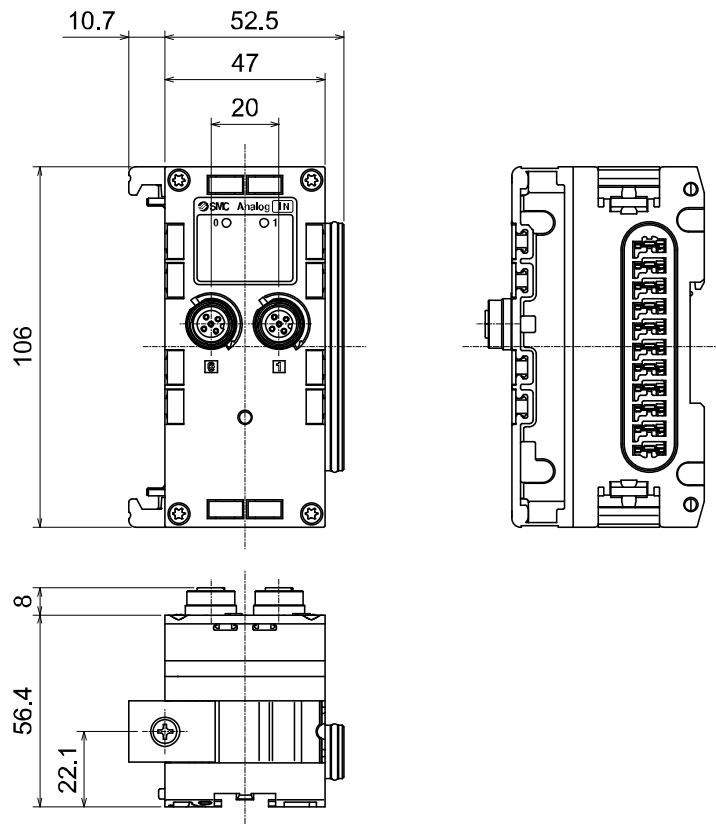

Analog output unit

Model Indication and How to Order

EX600-AY□

Analog output

Connector and number of output channels

Symbol	Connector	Number of output channels
A	2xM12 connector (5 pin) *	2 channels

*: An M12 connector (4 pin) can also be connected.

Names and Functions of Product

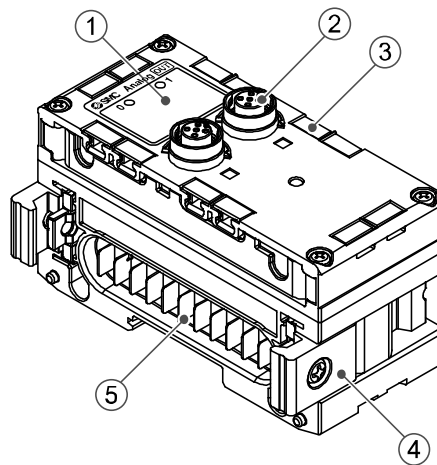

No.	Description	Function
1	Status display LED	Displays the status of the unit.
2	Connector (Analog output)	Connector for analog output device.
3	Marker groove	Groove to mount a marker.
4	Joint bracket	Bracket for joining to adjacent units.
5	Unit Connector (Plug)	Transmits signals and power supplies to adjacent units.

Mounting and Installation

■Wiring

○Connector pin assignment and circuit diagram

•Connector pin assignment

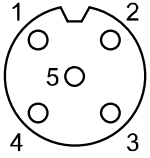
Configuration	Pin number	Signal name
	1	24V (Output)
	2	Output
	3	0V (Output)
	4	0V (Output)
	5	FE

*: An M12 connector (4 pin) can also be connected.

•Circuit diagram

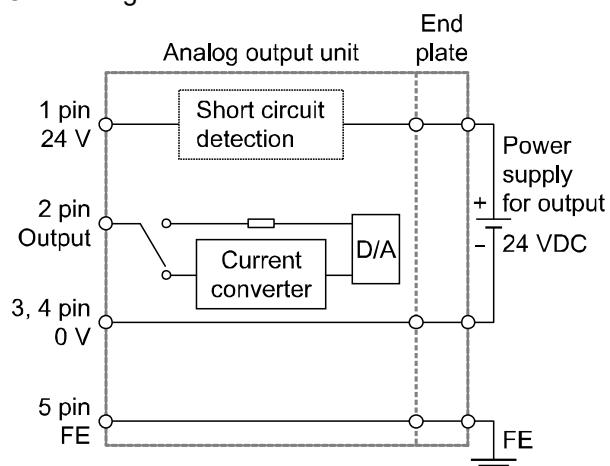

Load impedance

Voltage output: 1 k Ω or more

Current output: 600 Ω or less

●Precautions for handling

Be sure to fit a seal cap on any unused connectors. Proper use of the seal cap enables the enclosure to achieve IP67 specification.

LED Display

The status display LED shows the following unit status.
Various kinds of status can be checked as follows:

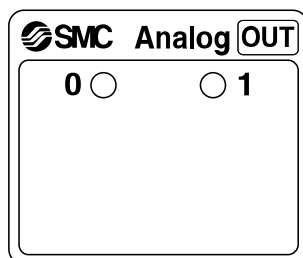

Display	Content
○ OFF	The power supply for the control and input is OFF.
● Green LED is ON	The product is operating normally.
● Red LED is ON	The power supply of output device has a short circuit.
⊙ Red LED is flashing	The upper or lower limit of the output value (With user's setting value) is exceeded.

*: Refer to troubleshooting (SI unit Operation Manual of protocol used) for the further details of countermeasures.

Specification

■ Specifications

Model		EX600-AYA		
Output Specifications	Output type	Voltage output type	Current output type	
	Output connector	M12 connector (5 pin) Socket *1		
	Number of output channels	2 channels (1 channel/Connector)		
	Power supply voltage (Control and input)	24 VDC Class2, 2 A		
	Power supply voltage (Output)	24 VDC Class2, 2 A		
	Max. load current	0.5 A/Channel		
	Protective function	Short circuit protection		
	Output signal range	12 bit Resolution *2	0 to 10 V, 1 to 5 V, 0 to 5 V	0 to 20 mA, 4 to 20 mA
	Load impedance	1 kΩ or more	600 Ω or less	
	Linearity	±0.05% F.S or less		
	Repeatability	±0.15% F.S. or less		
	Absolute accuracy	±0.5% F.S. or less	±0.6% F.S. or less	
	Current consumption	70 mA or less		
Environment	Enclosure	IP67 (With manifold assembled) *3		
	Operating temperature range	-10 to 50 °C (Max. surrounding air temperature rating: 50 °C) *4		
	Storage temperature range	-20 to 60 °C		
	Operating humidity range	35 to 85%RH (No condensation)		
	Withstand voltage	500 VAC for 1 minute between external terminals and FE		
	Insulation resistance	500 VDC, 10 MΩ min. between external terminals and FE		
Pollution degree	For use in Pollution Degree 3 Environment (UL508)			
Standard	CE/UKCA marked, UL(CSA)			
Weight	290 g			

*1: An M12 connector (4 pin) can also be connected.

*2: All unused connectors must have a seal cap fitted.

*3: The UL compliant temperature is 0 to 50 °C.

•Analog output characteristics

(1)Offset binary date format

- Output signal range: 0 to 10 V, 0 to 5 V, 0 to 20 mA
- Output signal range: 1 to 5 V, 4 to 20 mA

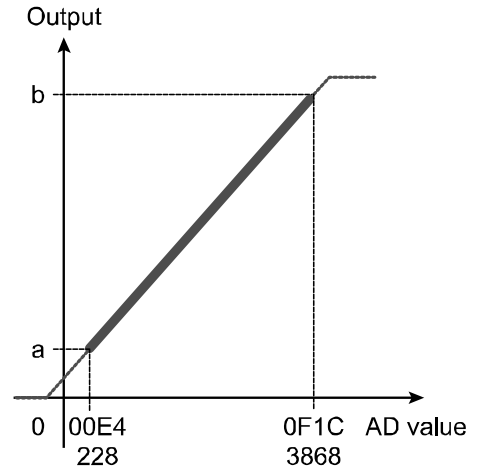
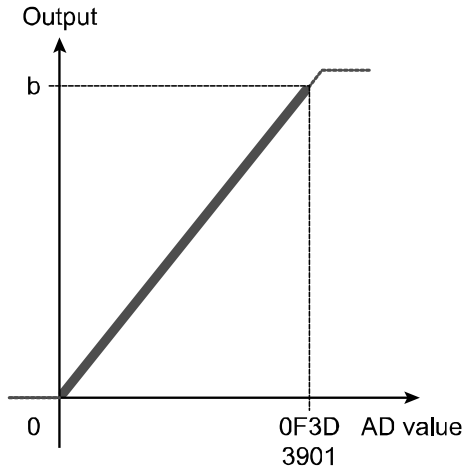

AD value		Output signal range (0 to b)		
Hexadecimal number	Decimal number	Voltage [V]		Current [mA]
		0 to 10 V	0 to 5 V	0 to 20 mA
0FFF	4095	10.5	5.25	21
0F3D	3901	10	5	20
0800	2048	5.25	2.625	10.5
0000	0	0	0	0

AD value		Output signal range (a to b)		
Hexadecimal number	Decimal number	Voltage [V]		Current [mA]
		1 to 5 V	4 to 20 mA	
0FFF	4095	5.25	21	
0F1C	3868	5	20	
0800	2048	3	12	
00E4	228	1	4	
0000	0	0.75	3	

•Data format

		Byte0								Byte1											
CH0		15	14	13	12	11	10	9	8	7	6	5	4	3	2	1	0				
		0	0	0	0	MSB								AD value							
CH1		15	14	13	12	11	10	9	8	7	6	5	4	3	2	1	0				
		0	0	0	0	MSB								AD value							

(2) Signed binary data format and two's complement data format

- Output signal range: 0 to 10 V, 0 to 5 V, 0 to 20 mA
- Output signal range: 1 to 5 V, 4 to 20 mA

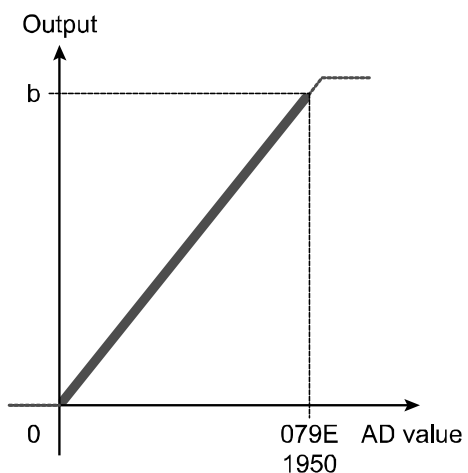

AD value		Output signal range (0 to b)		
Hexadecimal number	Decimal number	Voltage [V]		Current [mA]
		0 to 10 V	0 to 5 V	0 to 20 mA
07FF	2047	10.5	5.25	21
079E	1950	10	5	20
0400	1024	5.25	2.625	10.5
0000	0	0	0	0

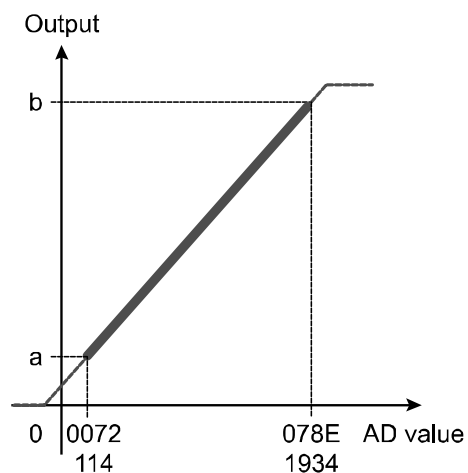

AD value		Output signal range (a to b)	
Hexadecimal number	Decimal number	Voltage [V]	Current [mA]
		1 to 5 V	4 to 20 mA
07FF	2047	5.25	21
078E	1934	5	20
0400	1024	3	12
0072	114	1	4
0000	0	0.75	3

•Data format

	Byte0								Byte1								
CH0	15	14	13	12	11	10	9	8	7	6	5	4	3	2	1	0	
	0	0	0	0	Sign	MSB			AD value								LSB
	Byte2								Byte3								
CH1	15	14	13	12	11	10	9	8	7	6	5	4	3	2	1	0	
	0	0	0	0	Sign	MSB			AD value								LSB

(3) Scaled data format

In the scaled data format, AD values corresponding to the output signal range can be optionally set between FFFF and 7FFF or -32767 and 32767. The resolution can be set by specifying the upper and lower limits of the scale.

$$\text{Resolution} = \frac{\text{Upper limit value of the range} - \text{Lower limit value of the range}}{\text{Upper limit value of the scale} - \text{Lower limit value of the scale}}$$

Example: when the range is 1 to 5 V

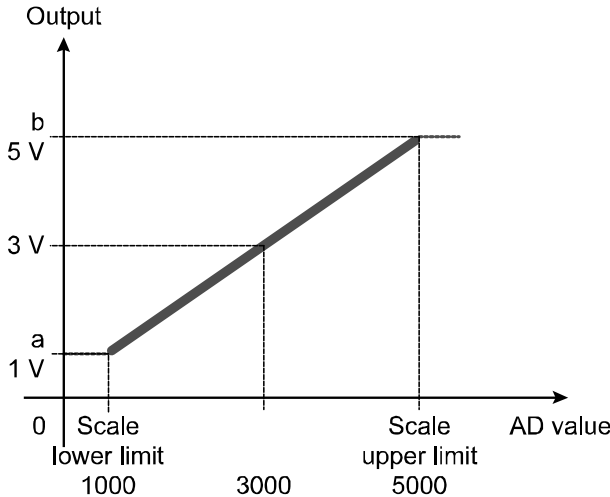

1. Set the range to 1 to 5 V.
2. When the upper limit of the scale is set to 5000, and the lower limit of the scale is set to 1000, the result will be as follows.
 - 1000 ... 1 V is output
 - 2000 ... 2 V is output
 - 3000 ... 3 V is output
 - 4000 ... 4 V is output
 - 5000 ... 5 V is output
3. The resolution from 1 to 5 V is 1/1000 based on the calculation $(5\text{ V} - 1\text{ V}) / (5000 - 1000) = 1/1000$.

	AD value		Output signal range (a to b)				
	Hexadecimal number	Decimal number	Voltage [V]			Current [mA]	
			0 to 10 V	1 to 5 V	0 to 5 V	0 to 20 mA	4 to 20 mA
Scale upper limit	FFFE to 7FFF	-32766 to 32767	10	5	5	20	20
Scale lower limit	FFFF to 7FFE	-32767 to 32766	0	1	0	0	4

•Data format

		Byte0								Byte1							
CH0		15	14	13	12	11	10	9	8	7	6	5	4	3	2	1	0
	Sign	MSB								AD value							
		Byte2								Byte3							
CH1		15	14	13	12	11	10	9	8	7	6	5	4	3	2	1	0
	Sign	MSB								AD value							

•Precautions for handling

When setting, make sure that the scale upper limit value is larger than the scale lower limit value (Scale lower limit value < Scale upper limit value).

■Dimensions

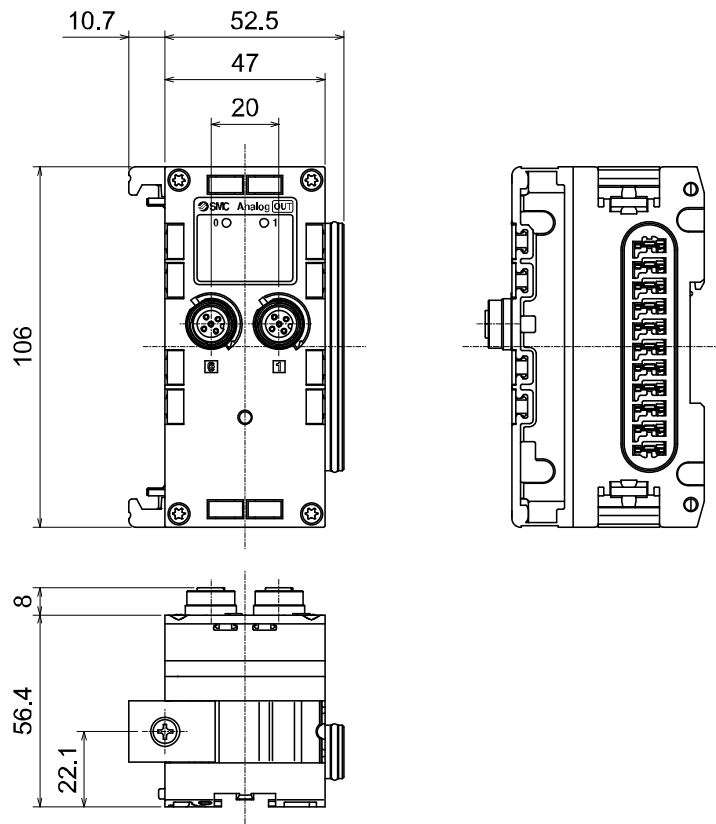

Analog I/O unit

Model Indication and How to Order

EX600-AM□

Analog I/O

Connector and number of channels

Symbol	Connector	Number of input channels	Number of output channels
B	4xM12 connector (5 pin) *	2 channels	2 channels

□*: An M12 connector (4 pin) can also be connected.

Names and Functions of Product

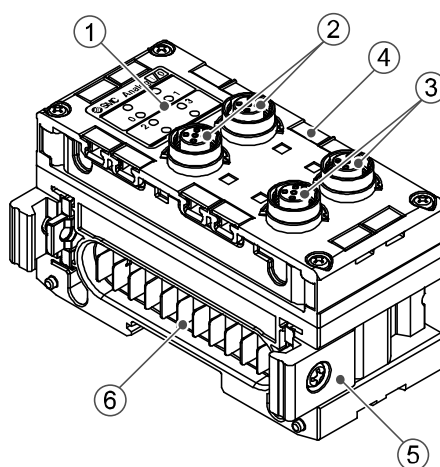

No.	Description	Function
1	Status display LED	Displays the status of the unit.
2	Connector (Analog input)	Connector for analog input device.
3	Connector (Analog output)	Connector for analog output device.
4	Marker groove	Groove to mount a marker.
5	Joint bracket	Bracket for joining to adjacent units.
6	Unit connector (Plug)	Transmits signals and power supplies to adjacent units.

Mounting and Installation

■Wiring

○Connector pin assignment and circuit diagram

•Connector pin assignment

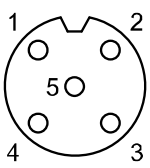
Configuration	Pin number	Signal name	
		Input connector	Output connector
	1	24 V (Control and Input)	24 V (Output)
	2	Input +	Output
	3	0 V (Control and input)	0 V (Output)
	4	Input -	0 V (Output)
	5	FE	FE

*: An M12 connector (4 pin) can also be connected.

•Circuit diagram

•Input circuit diagram

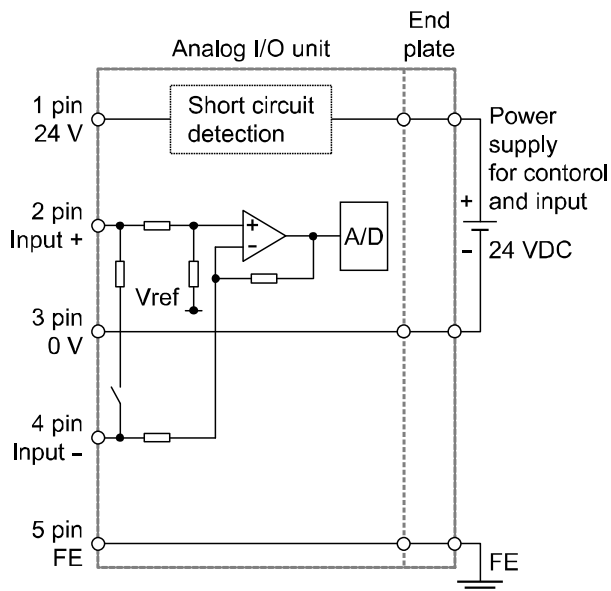

Input impedance

Voltage input: 100 k Ω
Current input: 250 Ω

•Output circuit diagram

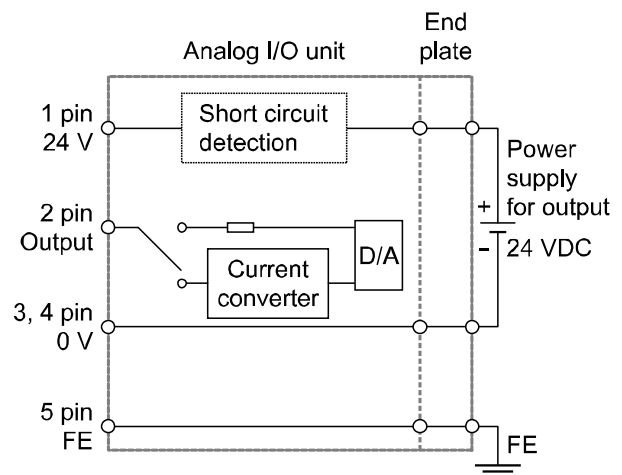

Load impedance

Voltage output: 1 k Ω or more
Current output: 600 Ω or less

•Precautions for handling

Be sure to fit a seal cap on any unused connectors. Proper use of the seal cap enables the enclosure to achieve IP67 specification.

○ Examples of wiring with input devices

- When using a sensor whose analog output signal is 0 V standard type.

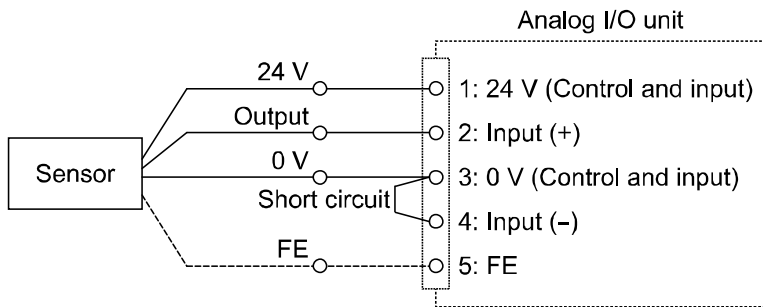

- When using a 2-wire current output type sensor.

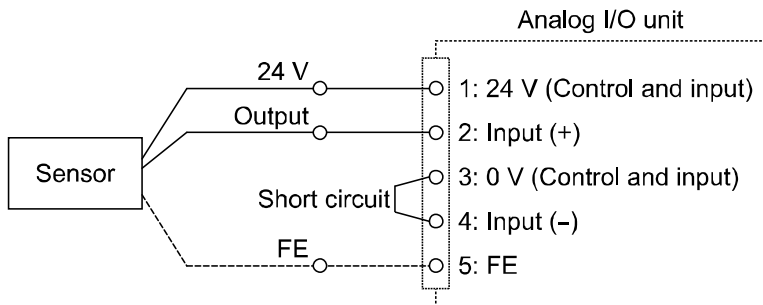

- When using a differential output type sensor.

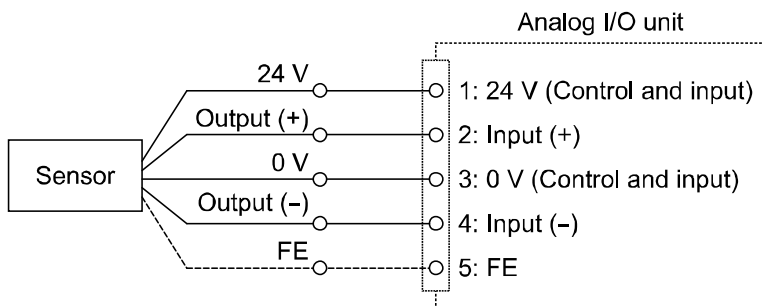

● Precautions for handling

When an analog sensor is connected to the Analog I/O unit, pay attention to the following cautions.

EX600 analog input has a differential input specification, and it receives 2-pin (input +) signal based on 4-pin (input -). Because of the specification, if 4-pin is not connected, it will not be able to read the signal input properly. Therefore, when using an analog sensor that does not have the differential output type, 3-pin and 4-pin should be connected externally.

LED Display

The status display LED shows following unit status.
Various kinds of status can be checked as follows:

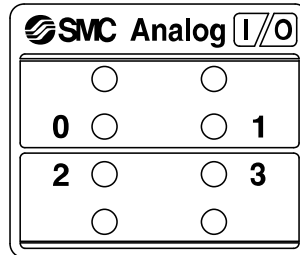

Display	Content	
	Input	Output
○ OFF	The power supply for control and input is OFF.	The power supply for control and input is OFF.
● Green LED is ON	The product is operating normally.	The product is operating normally.
● Red LED is ON	The power supply of input device has a short circuit.	The power supply of output device has a short circuit.
0 ● ● 1 0 and 1 red LEDs are ON	Either of the following conditions: •The current value of the analog input device has exceeded the upper or lower limit. •When the range is set by current input type, voltage is input from the analog input device.	/
⚡ Red LED is flashing	Either of the following conditions: •The upper or lower limit of the range is exceeded. •The upper or lower limit of the measuring value (With user's setting value) is exceeded.	The upper or lower limit of the output value (With user's setting value) is exceeded.

*: Refer to troubleshooting (SI unit Operation Manual of protocol used) for the further details of countermeasures.

Specification

■ Specifications

Model		EX600-AMB		
Input specifications	Input type	Voltage input type	Current input type	
	Input connector	M12 connector (5 pin) Socket *1		
	Number of input channels	2 channels (1 channel/Connector)		
	Power supply voltage (Control and input)	24 VDC Class2, 2 A		
	Max. sensor supply current	0.5 A/Channel		
	Protective function	Short circuit protection		
	Input signal range	12 bit Resolution *2	0 to 10 V, 1 to 5 V, 0 to 5 V	0 to 20 mA, 4 to 20 mA
	Max. rated input signal		15 V	40 mA
	Input impedance		100 k Ω	250 Ω
	Linearity (25 °C)		$\pm 0.05\%$ F.S. or less	
	Repeatability (25 °C)		$\pm 0.15\%$ F.S. or less	
	Absolute accuracy (25 °C)		$\pm 0.5\%$ F.S. or less	$\pm 0.6\%$ F.S. or less
Output specifications	Output type	Voltage output type	Current output type	
	Output connector	M12 connector (5 pin) Socket *1		
	Number of output channels	2 channels (1 channel/Connector)		
	Power supply voltage (Output)	24 VDC Class2, 2 A		
	Max. load current	0.5 A/Channel		
	Protective function	Short circuit protection		
	Output signal range	12 bit Resolution *2	0 to 10 V, 1 to 5 V, 0 to 5 V	0 to 20 mA, 4 to 20 mA
	Load impedance		1 k Ω or more	600 Ω or less
	Linearity (25 °C)		$\pm 0.05\%$ F.S. or less	
	Repeatability (25 °C)		$\pm 0.15\%$ F.S. or less	
	Absolute accuracy (25 °C)		$\pm 0.5\%$ F.S. or less	$\pm 0.6\%$ F.S. or less
	Current consumption	100 mA or less		
Environment	Enclosure	IP67 (With manifold assembled) *3		
	Operating temperature range	-10 to 50 °C (Max. surrounding air temperature rating: 50 °C) *4		
	Storage temperature range	-20 to 60 °C		
	Operating humidity range	35 to 85%RH (No condensation)		
	Withstand voltage	500 VAC for 1 min. between external terminals and FE		
	Insulation resistance	500 VDC, 10 M Ω or more between external terminals and FE		
	Pollution degree	For use in Pollution Degree 3 Environment (UL508)		
Standard	CE/UKCA marked, UL (CSA)			
Weight	300 g			

*1: An M12 (4 pin) connector can also be connected.

*2: All unused connectors must have a seal cap fitted.

*3: □ The UL compliant temperature is 0 to 50 °C.

○Analog input characteristics

(1)Offset binary data format

•Input signal range: 0 to 10 V, 0 to 5 V, 0 to 20 mA

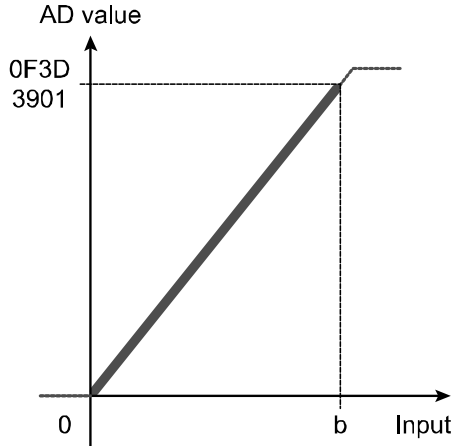

AD value		Input signal range (0 to b)		
Hexadecimal number	Decimal number	Voltage [V]		Current [mA]
		0 to 10 V	0 to 5 V	0 to 20 mA
0FFF	4095	10.5	5.25	21
0F3D	3901	10	5	20
0800	2048	5.25	2.625	10.5
0000	0	0	0	0

•Input signal range: 1 to 5 V, 4 to 20 mA

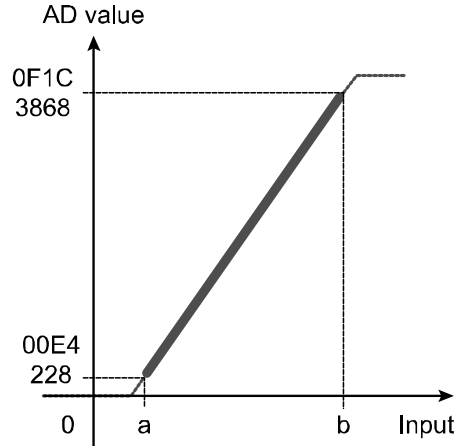

AD value		Input signal range (a to b)	
Hexadecimal number	Decimal number	Voltage [V]	
		1 to 5 V	4 to 20 mA
0FFF	4095	5.25	21
0F1C	3868	5	20
0800	2048	3	12
00E4	228	1	4
0000	0	0.75	3

•Data format

	Byte0								Byte1								
CH0	15	14	13	12	11	10	9	8	7	6	5	4	3	2	1	0	
	0	0	0	0	MSB				AD value								LSB
	Byte2								Byte3								
CH1	15	14	13	12	11	10	9	8	7	6	5	4	3	2	1	0	
	0	0	0	0	MSB				AD value								LSB

(2) Signed binary data format and two's complement data format

• Input signal range: 0 to 10 V, 0 to 5 V, 0 to 20 mA

• Input signal range: 1 to 5 V, 4 to 20 mA

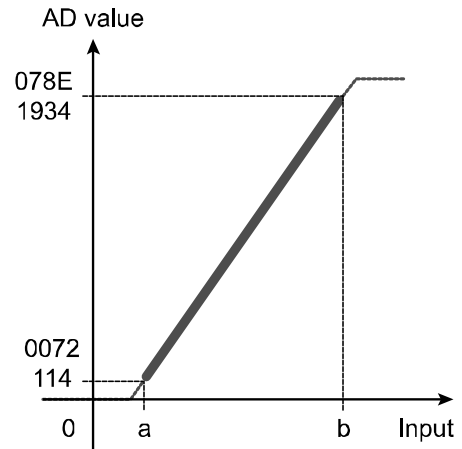
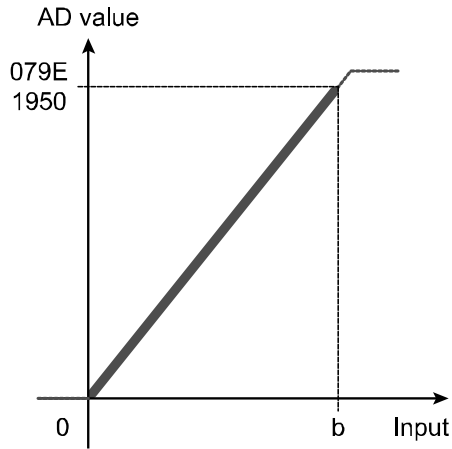

AD value		Input signal range (0 to b)		
Hexadecimal number	Decimal number	Voltage [V]		Current [mA]
		0 to 10 V	0 to 5 V	0 to 20 mA
07FF	2047	10.5	5.25	21
079E	1950	10	5	20
0400	1024	5.25	2.625	10.5
0000	0	0	0	0

AD value		Input signal range (a to b)		
Hexadecimal number	Decimal number	Voltage [V]		Current [mA]
		1 to 5 V	4 to 20 mA	
07FF	2047	5.25	21	
078E	1934	5	20	
0400	1024	3	12	
0072	114	1	4	
0000	0	0.75	3	

• Data format

		Byte0						Byte1									
CH0		15	14	13	12	11	10	9	8	7	6	5	4	3	2	1	0
		0	0	0	0	Sign	MSB		AD value								LSB
		Byte2						Byte3									
CH1		15	14	13	12	11	10	9	8	7	6	5	4	3	2	1	0
		0	0	0	0	Sign	MSB		AD value								LSB

(3) Scaled data format

In the scaled data format, AD values corresponding to the input signal range can be optionally set between FFFF and 7FFF or -32767 and 32767. The resolution can be set by specifying the upper and lower limits of the scale.

$$\text{Resolution} = \frac{\text{Upper limit value of the range} - \text{Lower limit value of the range}}{\text{Upper limit value of the scale} - \text{Lower limit value of the scale}}$$

Example: when the range is 1 to 5 V

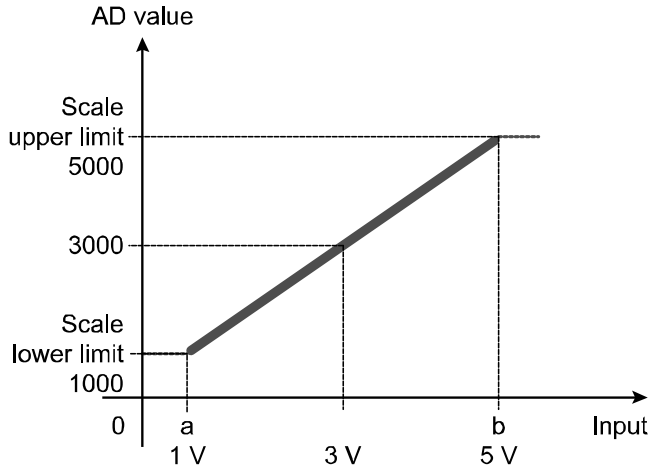

1. Set the range to 1 to 5 V.
2. When the upper limit of the scale is set to 5000, and the lower limit of the scale is set to 1000, the result will be as follows.
 - 1000 ... 1 V is input
 - 2000 ... 2 V is input
 - 3000 ... 3 V is input
 - 4000 ... 4 V is input
 - 5000 ... 5 V is input
3. The resolution from 1 to 5 V is 1/1000 based on the calculation $(5 \text{ V} - 1 \text{ V}) / (5000 - 1000) = 1/1000$.

	AD value		Input signal range (a to b)				
	Hexadecimal number	Decimal number	Voltage [V]			Current [mA]	
			0 to 10 V	1 to 5 V	0 to 5 V	0 to 20 mA	4 to 20 mA
Scale upper limit	FFFF to 7FFF	-32766 to 32767	10	5	5	20	20
Scale lower limit	FFFF to 7FFE	-32767 to 32766	0	1	0	0	4

•Data format

		Byte0								Byte1							
CH0		15	14	13	12	11	10	9	8	7	6	5	4	3	2	1	0
	Sign	MSB								AD value							
		Byte2								Byte3							
CH1		15	14	13	12	11	10	9	8	7	6	5	4	3	2	1	0
	Sign	MSB								AD value							

•Precautions for handling

When setting, make sure that the scale upper limit value is larger than the scale lower limit value (scale lower limit value < scale upper limit value).

•Analog output characteristics

(1)Offset binary date format

•Output signal range: 0 to 10 V, 0 to 5 V, 0 to 20 mA

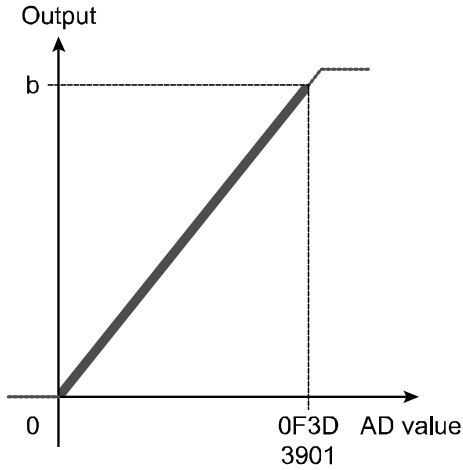

AD value		Output signal range (0 to b)		
Hexadecimal number	Decimal number	Voltage [V]		Current [mA]
		0 to 10 V	0 to 5 V	0 to 20 mA
0FFF	4095	10.5	5.25	21
0F3D	3901	10	5	20
0800	2048	5.25	2.625	10.5
0000	0	0	0	0

•Output signal range: 1 to 5 V, 4 to 20 mA

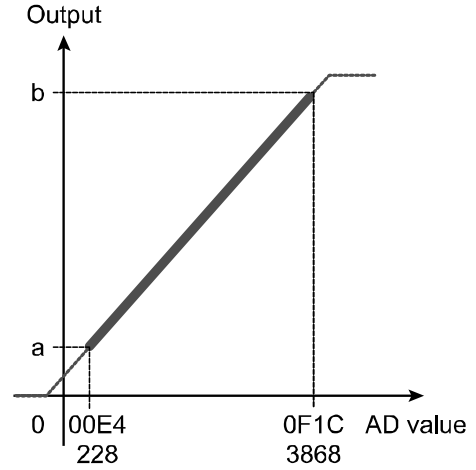

AD value		Output signal range (a to b)	
Hexadecimal number	Decimal number	Voltage [V]	Current [mA]
		1 to 5 V	4 to 20 mA
0FFF	4095	5.25	21
0F1C	3868	5	20
0800	2048	3	12
00E4	228	1	4
0000	0	0.75	3

•Data format

		Byte0								Byte1							
CH2		15	14	13	12	11	10	9	8	7	6	5	4	3	2	1	0
		0	0	0	0	MSB				AD value							
		Byte1								Byte2							
CH3		15	14	13	12	11	10	9	8	7	6	5	4	3	2	1	0
		0	0	0	0	MSB				AD value							

(2) Signed binary data format and two's complement data format

- Output signal range: 0 to 10 V, 0 to 5 V, 0 to 20 mA
- Output signal range: 1 to 5 V, 4 to 20 mA

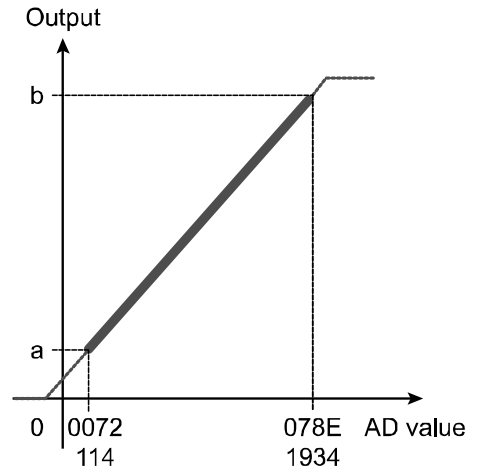
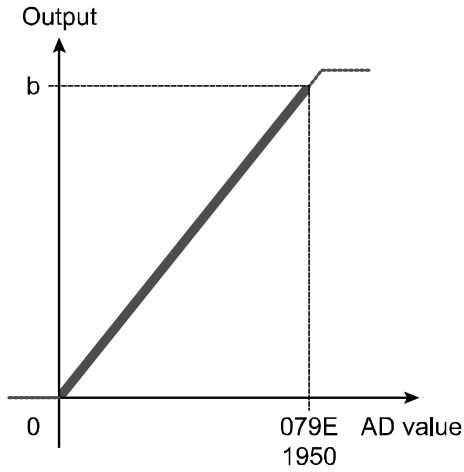

AD value		Output signal range (0 to b)		
Hexadecimal number	Decimal number	Voltage [V]		Current [mA]
		0 to 10 V	0 to 5 V	0 to 20 mA
07FF	2047	10.5	5.25	21
079E	1950	10	5	20
0400	1024	5.25	2.625	10.5
0000	0	0	0	0

AD value		Output signal range (a to b)		
Hexadecimal number	Decimal number	Voltage [V]		Current [mA]
		1 to 5 V	4 to 20 mA	
07FF	2047	5.25	21	
078E	1934	5	20	
0400	1024	3	12	
0072	114	1	4	
0000	0	0.75	3	

•Data format

		Byte0								Byte1							
CH2		15	14	13	12	11	10	9	8	7	6	5	4	3	2	1	0
		0	0	0	0	Sign	MSB AD value										LSB
		Byte2								Byte3							
CH3		15	14	13	12	11	10	9	8	7	6	5	4	3	2	1	0
		0	0	0	0	Sign	MSB AD value										LSB

(3) Scaled data format

In the scaled data format, AD values corresponding to the input signal range can be optionally set between FFFF and 7FFF or -32767 and 32767. The resolution can be set by specifying the upper and lower limits of the scale.

$$\text{Resolution} = \frac{\text{Upper limit value of the range} - \text{Lower limit value of the range}}{\text{Upper limit value of the scale} - \text{Lower limit value of the scale}}$$

Example: when the range is 1 to 5 V

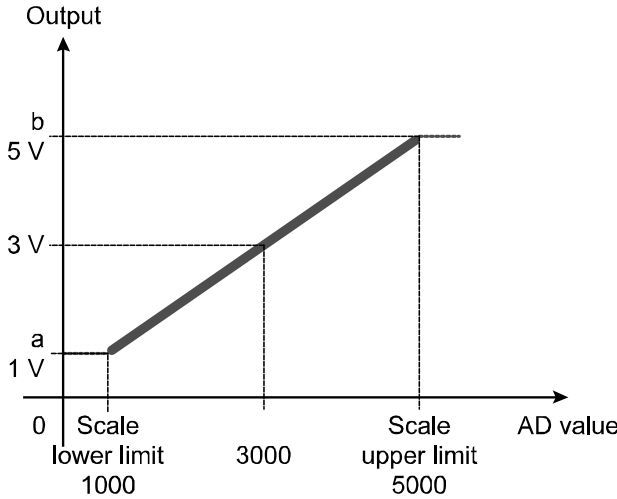

1. Set the range to 1 to 5 V.
2. When the upper limit of the scale is set to 5000, and the lower limit of the scale is set to 1000, the result will be as follows.
 - 1000 ... 1 V is output
 - 2000 ... 2 V is output
 - 3000 ... 3 V is output
 - 4000 ... 4 V is output
 - 5000 ... 5 V is output
3. The resolution from 1 to 5 V is 1/1000 based on the calculation $(5\text{ V} - 1\text{ V}) / (5000 - 1000) = 1/1000$.

	AD value		Output signal range (a to b)				
	Hexadecimal number	Decimal number	Voltage [V]			Current [mA]	
			0 to 10 V	1 to 5 V	0 to 5 V	0 to 20 mA	4 to 20 mA
Scale upper limit	FFFE to 7FFF	-32766 to 32767	10	5	5	20	20
Scale lower limit	FFFF to 7FFE	-32767 to 32766	0	1	0	0	4

•Data format

		Byte0								Byte1							
CH2		15	14	13	12	11	10	9	8	7	6	5	4	3	2	1	0
	Sign	MSB								AD value							
		Byte2								Byte3							
CH3		15	14	13	12	11	10	9	8	7	6	5	4	3	2	1	0
	Sign	MSB								AD value							

•Precautions for handling

When setting, make sure that the scale upper limit value is larger than the scale lower limit value (scale lower limit value < scale upper limit value).

■Dimensions

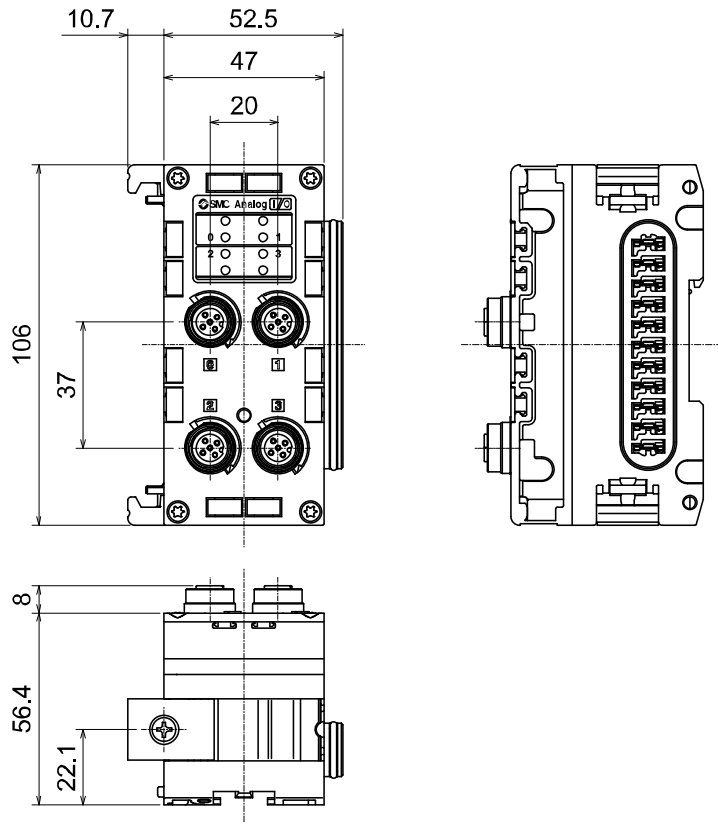

Common items

Maintenance

Turn off the power supply, stop the supplied air, exhaust the residual pressure and verify the release of air before performing maintenance.

Cleaning method

Use a soft cloth to remove stains.

For heavy stains, use a cloth soaked with diluted neutral detergent and fully squeezed, then wipe up the stains again with a dry cloth.

Do not use solvents such as benzene, thinner etc. to clean each unit.

Inspection item	Content of inspection
Connector/Electric wiring	Connect properly if the connection is loose.
Seal cap	Tighten properly if the connection is loose.
Thread for mounting and installation	If the thread is loose, re-tighten it to the specified torque.
Connection cables	If the cable is broken or any other abnormality is confirmed by appearance, replace the cable with a new one.
Supply source voltage	Check if source voltage within the specification range (24 VDC \pm 10%) is supplied.

How to reset the product for power cut or forcible de-energizing

Supply power to the product.

The output status just before the power failure is not maintained when power supply is recovered.

Start operation after confirming safety of the entire equipment.

Troubleshooting

Refer to the SI unit Operation Manual of protocol used.

Parameter Setting

Refer to the SI unit Operation Manual of protocol used.

I/O Map

Refer to the SI unit Operation Manual of protocol used.

Diagnostic

Refer to the SI unit Operation Manual of protocol used.

Accessories

Refer to the SI unit Operation Manual of protocol used.

Precautions before mounting

The units that can be connected vary depending on the product number.
Check the applicable unit type before mounting the unit.

		SI Unit			
		EX600-SPR□ (PROFIBUS DP)	EX600-SPR□A (PROFIBUS DP)	EX600-SMJ□ (CC-Link)	EX600-SEN□ (EtherNet/IP)
		EX600-SDN□ (DeviceNet)	EX600-SDN□A (DeviceNet)		
Digital unit	EX600-DX□B	○	○	○	○
	EX600-DX□C□	○	○	○	○
	EX600-DX□D	○	○	○	○
	EX600-DX□E	×	○	○	○
	EX600-DX□F	×	○	○	○
	EX600-DY□B	○	○	○	○
	EX600-DY□E	×	○	○	○
	EX600-DY□F	×	○	○	○
	EX600-DM□E	×	○	○	○
	EX600-DM□F	×	○	○	○
Analog unit	EX600-AXA	○	○	○	○
	EX600-AYA	×	○	○	○
	EX600-AMB	×	○	○	○
H. T.	EX600-HT1	○	○	○	×
	EX600-HT1A	○	○	○	○

		H. T.	
		EX600-HT1-□	EX600-HT1A-□
SI Unit	EX600-SPR□ (PROFIBUS DP)	○	○
	EX600-SPR□A (PROFIBUS DP)	○	○
	EX600-SDN□ (DeviceNet)	○	○
	EX600-SDN□A (DeviceNet)	○	○
	EX600-SMJ□ (CC-Link)	○	○
	EX600-SEN□ (EtherNet/IP)	×	○
Digital Unit	EX600-DX□B	○	○
	EX600-DX□C□	○	○
	EX600-DX□D	○	○
	EX600-DX□E	×	○
	EX600-DX□F	×	○
	EX600-DY□B	○	○
	EX600-DY□E	×	○
	EX600-DY□F	×	○
	EX600-DM□E	×	○
	EX600-DM□F	×	○
Analog Unit	EX600-AXA	○	○
	EX600-AYA	×	○
	EX600-AMB	×	○

Revision history

- A: Contents revised in several places.
- B: Revision (Pollution degree)
- C: 「Limited warranty and Disclaimer」 and
「measurement laws」 are added.
- D: Contents revised in several places [May 2024]

SMC Corporation

Tel: + 81 3 5207 8249 Fax: +81 3 5298 5362

URL <https://www.smcworld.com>

Note: Specifications are subject to change without prior notice and any obligation on the part of the manufacturer.
© SMC Corporation All Rights Reserved

