



Operation Manual

PRODUCT NAME

Fieldbus system
(DeviceNet[®] compliant)

MODEL / Series / Product Number

EX510-GDN1 Series

SMC Corporation

Table of Contents

Safety Instructions	3
Model Indication and How to Order	8
Summary of Product Parts	9
Definition and terminology	10
Common Specifications	12
EX510 GW Unit	
Summary of Product Parts	13
Mounting and Installation	14
Installation	14
Wiring	15
Setting	20
Specification	24
Specifications	24
Dimensions	25
SI Unit	
Summary of Product Parts	26
Mounting and Installation	28
Installation	28
Wiring	29
Setting	33
Specification	33
Specifications	33
Dimensions	34
Output Unit	
Summary of Product Parts	35
Mounting and Installation	36
Installation	36
Wiring	37
Specification	40
Specifications	40
Dimensions	40

Input Unit

Summary of Product Parts	41
Mounting and Installation	42
Installation	42
Wiring	44
Specification	48
Specifications	48
Dimensions	48
Maintenance	49
Troubleshooting	50
Option	56



Safety Instructions

These safety instructions are intended to prevent hazardous situations and/or equipment damage. These instructions indicate the level of potential hazard with the labels of “**Caution**,” “**Warning**” or “**Danger**.” They are all important notes for safety and must be followed in addition to International Standards (ISO/IEC)^{*)}, and other safety regulations.

*1) ISO 4414: Pneumatic fluid power - General rules and safety requirements for systems and their components
ISO 4413: Hydraulic fluid power - General rules and safety requirements for systems and their components
IEC 60204-1: Safety of machinery - Electrical equipment of machines - Part 1: General requirements
ISO 10218-1: Robots and robotic devices - Safety requirements for industrial robots - Part 1: Robots
etc.



Danger

Danger indicates a hazard with a high level of risk which, if not avoided, will result in death or serious injury.



Warning

Warning indicates a hazard with a medium level of risk which, if not avoided, could result in death or serious injury.



Caution

Caution indicates a hazard with a low level of risk which, if not avoided, could result in minor or moderate injury.



Warning

1. The compatibility of the product is the responsibility of the person who designs the equipment or decides its specifications.

Since the product specified here is used under various operating conditions, its compatibility with specific equipment must be decided by the person who designs the equipment or decides its specifications based on necessary analysis and test results. The expected performance and safety assurance of the equipment will be the responsibility of the person who has determined its compatibility with the product. This person should also continuously review all specifications of the product referring to its latest catalog information, with a view to giving due consideration to any possibility of equipment failure when configuring the equipment.

2. Only personnel with appropriate training should operate machinery and equipment.

The product specified here may become unsafe if handled incorrectly. The assembly, operation and maintenance of machines or equipment including our products must be performed by an operator who is appropriately trained and experienced.

3. Do not service or attempt to remove product and machinery/equipment until safety is confirmed.

1. The inspection and maintenance of machinery/equipment should only be performed after measures to prevent falling or runaway of the driven objects have been confirmed.
2. When the product is to be removed, confirm that the safety measures as mentioned above are implemented and the power from any appropriate source is cut, and read and understand the specific product precautions of all relevant products carefully.
3. Before machinery/equipment is restarted, take measures to prevent unexpected operation and malfunction.

4. Our products cannot be used beyond their specifications. Our products are not developed, designed, and manufactured to be used under the following conditions or environments. Use under such conditions or environments is not covered.

1. Conditions and environments outside of the given specifications, or use outdoors or in a place exposed to direct sunlight.
2. Use for nuclear power, railways, aviation, space equipment, ships, vehicles, military application, equipment affecting human life, body, and property, fuel equipment, entertainment equipment, emergency shut-off circuits, press clutches, brake circuits, safety equipment, etc., and use for applications that do not conform to standard specifications such as catalogs and operation manuals.
3. Use for interlock circuits, except for use with double interlock such as installing a mechanical protection function in case of failure. Please periodically inspect the product to confirm that the product is operating properly.



Safety Instructions

Caution

We develop, design, and manufacture our products to be used for automatic control equipment, and provide them for peaceful use in manufacturing industries.

Use in non-manufacturing industries is not covered.

Products we manufacture and sell cannot be used for the purpose of transactions or certification specified in the Measurement Act.

The new Measurement Act prohibits use of any unit other than SI units in Japan.

Limited warranty and Disclaimer/Compliance Requirements

The product used is subject to the following “Limited warranty and Disclaimer” and “Compliance Requirements”.

Read and accept them before using the product.

Limited warranty and Disclaimer

1. The warranty period of the product is 1 year in service or 1.5 years after the product is delivered, whichever is first.*2)
Also, the product may have specified durability, running distance or replacement parts. Please consult your nearest sales branch.
2. For any failure or damage reported within the warranty period which is clearly our responsibility, a replacement product or necessary parts will be provided.
This limited warranty applies only to our product independently, and not to any other damage incurred due to the failure of the product.
3. Prior to using SMC products, please read and understand the warranty terms and disclaimers noted in the specified catalog for the particular products.

***2) Vacuum pads are excluded from this 1 year warranty.**

A vacuum pad is a consumable part, so it is warranted for a year after it is delivered.

Also, even within the warranty period, the wear of a product due to the use of the vacuum pad or failure due to the deterioration of rubber material are not covered by the limited warranty

Compliance Requirements

1. The use of SMC products with production equipment for the manufacture of weapons of mass destruction (WMD) or any other weapon is strictly prohibited.
2. The exports of SMC products or technology from one country to another are governed by the relevant security laws and regulations of the countries involved in the transaction. Prior to the shipment of a SMC product to another country, assure that all local rules governing that export are known and followed.

Operator

- ◆ This operation manual is intended for those who have knowledge of machinery using pneumatic equipment, and have sufficient knowledge of assembly, operation and maintenance of such equipment. Only those persons are allowed to perform assembly, operation and maintenance.
- ◆ Read and understand this operation manual carefully before assembling, operating or providing maintenance to the product.

■ Safety Instructions

Warning

- Do not disassemble, modify (including changing the printed circuit board) or repair.
An injury or failure can result.
- Do not operate the product outside of the specifications.
Do not use for flammable or harmful fluids.
Fire, malfunction, or damage to the product can result.
Verify the specifications before use.
- Do not operate in an atmosphere containing flammable or explosive gases.
Fire or an explosion can result.
This product is not designed to be explosion proof.
- If using the product in an interlocking circuit:
 - Provide a double interlocking system, for example a mechanical system.
 - Check the product regularly for proper operation.Otherwise malfunction can result, causing an accident.
- The following instructions must be followed during maintenance:
 - Turn off the power supply.
 - Stop the air supply, exhaust the residual pressure and verify that the air is released before performing maintenance.Otherwise an injury can result.

Caution

- After maintenance is complete, perform appropriate functional inspections.
Stop operation if the equipment does not function properly.
Safety cannot be assured in the case of unexpected malfunction.
- Provide grounding to assure the noise resistance of the GW unit.
Individual grounding should be provided close to the product with a short cable.

■NOTE

○Follow the instructions given below when designing, selecting and handling the product.

●The instructions on design and selection (installation, wiring, environment, adjustment, operation, maintenance, etc.) described below must also be followed.

*Product specifications

●When conformity to UL is required, the SI unit should be used with a UL1310 Class 2 power supply.

●Use the specified voltage.

Otherwise failure or malfunction can result.

●Reserve a space for maintenance.

Allow sufficient space for maintenance when designing the system.

●Do not remove any nameplates or labels.

This can lead to incorrect maintenance, or misreading of the operation manual, which could cause damage or malfunction to the product.

●It may also result in non-conformity to safety standards.

●Product handling

*Installation

●Do not drop, hit or apply excessive shock to the fieldbus system.

Otherwise damage to the product can result, causing malfunction.

●Tighten to the specified tightening torque.

If the tightening torque is exceeded the mounting screws may be broken.

●Never mount a product in a location that will be used as a foothold.

The product may be damaged if excessive force is applied by stepping or climbing onto it.

*Wiring

●Avoid repeatedly bending or stretching the cables, or placing heavy load on them.

Repetitive bending stress or tensile stress can cause breakage of the cable.

●Wire correctly.

Incorrect wiring can break the product.

●Do not perform wiring while the power is on.

Otherwise damage to the fieldbus system and/or I/O device can result, causing malfunction.

●Do not route wires and cables together with power or high voltage cables.

Otherwise the fieldbus system and/or I/O device can malfunction due to interference of noise and surge voltage from power and high voltage cables to the signal line.

Route the wires (piping) of the fieldbus system and/or I/O device separately from power or high voltage cables.

●Confirm proper insulation of wiring.

Poor insulation (interference from another circuit, poor insulation between terminals, etc.) can lead to excess voltage or current being applied to the product, causing damage.

●Take appropriate measures against noise, such as using a noise filter, when the fieldbus system is incorporated into equipment.

Otherwise noise can cause malfunction.

●Separate the power line for output devices from the power line for input devices and controlling GW.

Otherwise noise or induced surge voltage can cause malfunction.

*Environment

- Do not use the product in area that is exposed to corrosive gases, chemicals, sea water, water or steam.
Otherwise failure or malfunction can result.
- Do not use in an area where surges are generated.
If there is equipment which generates a large amount of surge (solenoid type lifter, high frequency induction furnace, motor, etc.) close to the fieldbus system, this may cause deterioration or breakage of the internal circuit of the fieldbus system. Avoid sources of surge generation and crossed lines.
- When a surge-generating load such as a relay or solenoid is driven directly, use an fieldbus system with a built-in surge absorbing element.
Direct drive of a load generating surge voltage can damage the fieldbus system.
- The product is CE/UKCA marked, but not immune to lightning strikes. Take measures against lightning strikes in the system.
- Prevent foreign matter such as remnant of wires from entering the fieldbus system to avoid failure and malfunction.
- Mount the product in a place that is not exposed to excessive vibration or impact.
Otherwise failure or malfunction can result.
- Do not use the product in an environment that is exposed to temperature cycle.
Heat cycles other than ordinary changes in temperature can adversely affect the inside of the product.
- Do not expose the product to direct sunlight.
If using in a location directly exposed to sunlight, shade the product from the sunlight.
Otherwise failure or malfunction can result.
- Keep within the specified ambient temperature range.
Otherwise malfunction can result.
- Do not operate close to a heat source, or in a location exposed to radiant heat.
Otherwise malfunction can result.

*Adjustment and Operation

- Set the switches by using a sharp-pointed screwdriver etc.
It may damage set switches.
- Perform settings suitable for the operating conditions.
Incorrect setting can cause operation failure.
- Please refer to the PLC manufacturer's manual etc. for details of programming and addresses.
For the PLC protocol and programming refer to the relevant manufacturer's documentation.

*Maintenance

- Turn off the power supply, stop the supplied air, exhaust the residual pressure and verify the release of air before performing maintenance.
There is a risk of unexpected malfunction.
- Perform regular maintenance and inspections.
There is a risk of unexpected malfunction.
- After maintenance is complete, perform appropriate functional inspections.
Stop operation if the equipment does not function properly.
Otherwise safety is not assured due to an unexpected malfunction or incorrect operation.
- Do not use solvents such as benzene, thinner etc. to clean the each unit.
They could damage the surface of the body and erase the markings on the body.
Use a soft cloth to remove stains.
For heavy stains, use a cloth soaked with diluted neutral detergent and fully squeezed, then wipe up the stains again with a dry cloth.

Model Indication and How to Order

- GW unit: DeviceNet® compatible



- Input unit

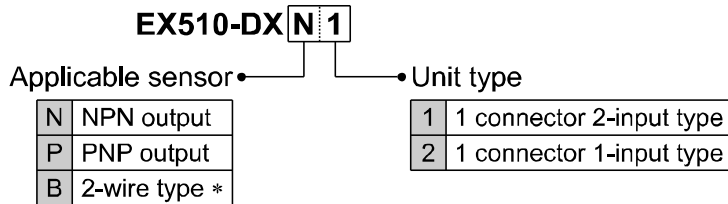

*: B (2-wire type) is available with 1 connector, 2-input type only.

- SI unit

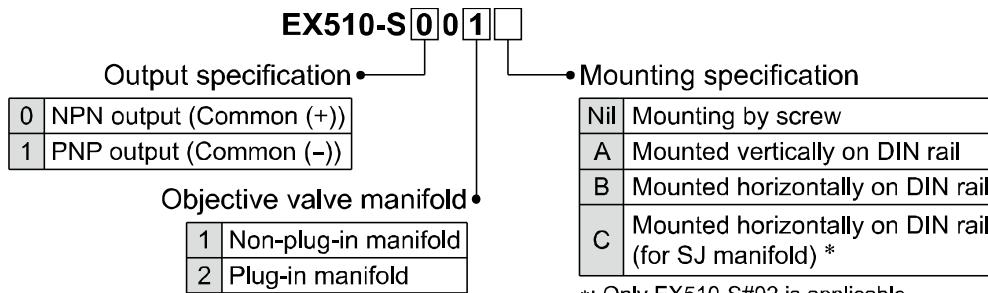

*: Only EX510-S#02 is applicable.

- Output unit

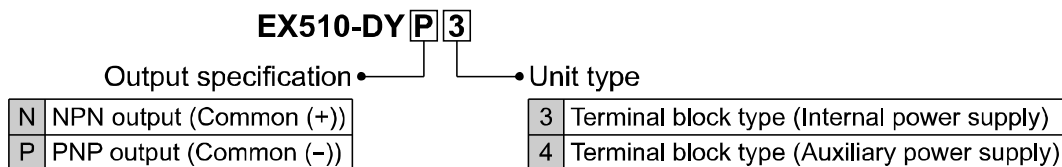

For the detail of part no. of solenoid valve manifold and independent solenoid valve with SI unit, refer to Operation Manual or other equivalent documents of used solenoid valve.

Summary of Product Parts

•System structure

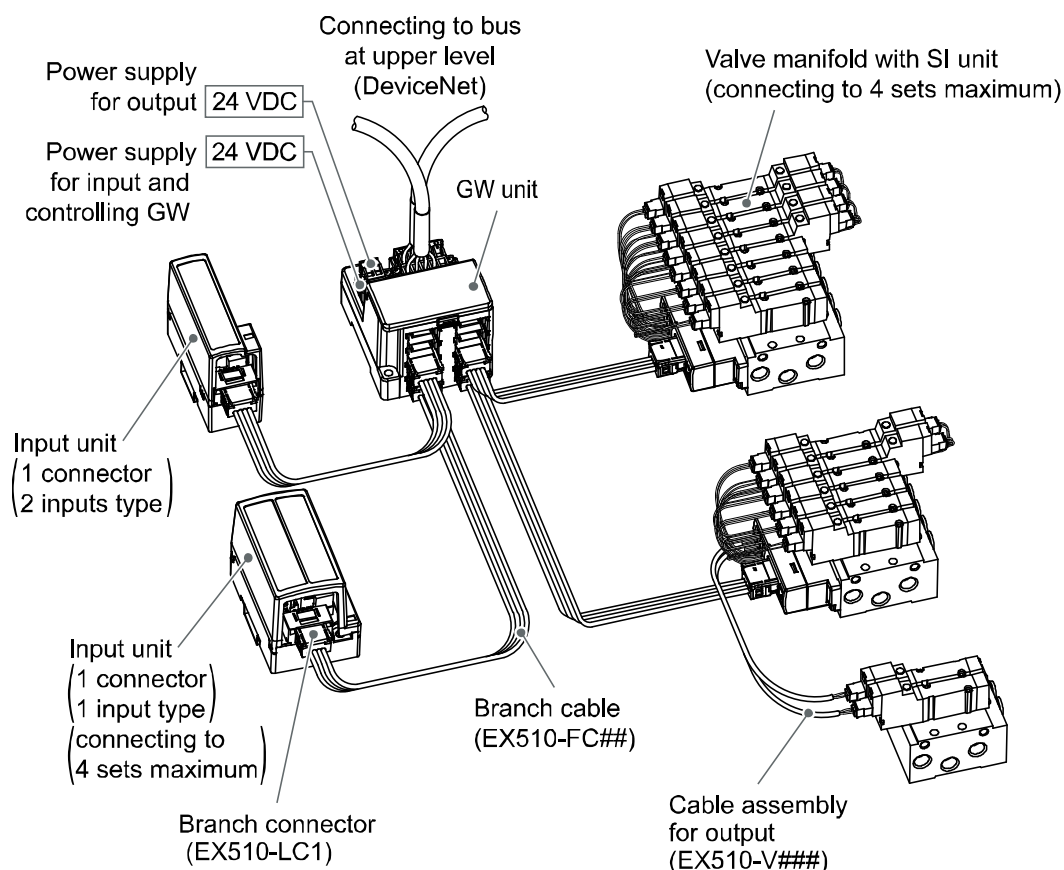

- Capable of decentralized control of 64 input points/64 output points.
Decentralized control of 4 input branches (maximum points of 16 x 4 branches) and 4 output branches (maximum points of 16 x 4 branches) per one GW unit is possible.
- Easy setting and wiring
Slave side does not need switch settings, but GW unit needs them such as address setting.
It is possible to adjust length of branch cable and crimp branch cable without dedicated tool.
Each slave does not need individual power supply because the branch cable is 4-core flat cable including a power supply line.
- Compact design
Small and compact design is applied for all of GW unit which realizes decentralized control, Input unit which connects input equipments such as sensor, and SI unit which connects output equipment such as solenoid valve.
- Flexible setting of number of occupied station
Utilize I/O point effectively by setting number of occupied station of GW unit.
- Applicable to each type of solenoid valves
SMC's solenoid valves can be easily wired for serial communication.
(Refer to Manifold Valve for applicable valve.)
The extra output of SI unit can be used to actuate 2-port valve etc, with a cable assembly for output.

■ Definition and terminology

	Term	Meaning
A	Address (Station address)	A number allocated to identify the unit connected on the DeviceNet® network. It is not allowed to be duplicated.
B	Branch wiring	A method to branch and connect a communication line and power line from GW unit to SI unit and Input unit.
C	Communication connector	A connecting part to transmit a communication signal which goes and returns between equipments in field bus.
	Communication port	A connection port to distribute a communication line and power line from GW unit to SI unit and Input unit.
	Communication speed	A speed at which data is sent and received in field bus etc. It depends on an equipment (PLC etc.) at high side and is indicated by bps (bit per second).
	Connector lock pin	A pin that prevents the connector for connecting load to be connected to SI unit from coming off.
	Conductor resistance	A electric resistance of a conductor. It is a value to show ease of current flow.
	Current consumption	A current necessary to operate a product normally. In this case, the current applied to a load is not included.
	Current sink type (NPN output)	An output configuration of an input equipment which uses NPN transistor for signal outputting part. It sinks current with input and that is the reason why it is called sink.
	Current source type (PNP output)	An output configuration of an input equipment which uses PNP transistor for signal outputting part. It sources current with input and that is the reason why it is called source.
D	Data rate	An amount of data which can be sent from one equipment to the other equipment. Referred to as transmission speed of data.
	DeviceNet®	An open Fieldbus for factory automation, developed by Rockwell Automation. It came into wide use mainly in US and became widespread in Europe, Japan and China.
	Diagnostic information	Diagnostic information from the GW unit. It is composed of the standard diagnostic information defined by DeviceNet® and the peculiar diagnostic information to GW unit.
	DIN rail	A metallic rail conforming with DIN (German Federation) standard.
E	Enclosure (IP)	An abbreviation of Ingress Protection. It is a standard related to protection of a product from foreign matters (hand, steel ball, steel wire, dust, water etc.).
F	FG	An abbreviation of frame ground meaning a body ground. Used to show a ground simply.
	Field bus	A standard which uses digital communication to transmit a signal between an equipment running at factory and field (instrumentation and operation equipment) and controller.
G	GND	An abbreviation of ground meaning reference voltage for signal. It has a same potential level as a shield wire (sheath) of signal line and connector and is referred to as a reference potential to transmit an electrical signal.
	GW unit	A unit used to connect protocols conforming with different standards in one network. In this system, it is regarded as a unit to adjust between DeviceNet® protocol and SMC dedicated protocol and connect them.

	Term	Meaning
I	Impedance	A resistance generated when alternating current is applied to a circuit. Referred to as alternating current resistance.
	Input delay time	Refer to "Transmission delay".
	Input point	The number of point which can receive information from an input equipment (sensor, switch etc.).
L	LED	An abbreviation of Light Emitting Diode meaning a kind of semiconductor element which emits light when current is applied.
M	MAC ID	An abbreviation of Media-Access-Control Identification. It is regarded as the node address specified by the DeviceNet® standard.
	Manifold	A component used to join many valves into one.
	MNS	An abbreviation of module status/network status. It shows if the power is applied to the GW unit and if the DeviceNet® operates normally including its communication status.
N	NPN output	An output configuration which operates an output equipment by using NPN transistor. Referred to as positive common type because positive potential is applied to common wire of power supply.
O	Opt-coupler insulation	A method for insulation by converting an electric signal to an optic signal once and using an element called opt-coupler which shows "1" and "0" when turned on and off. An opt-coupler has a part to convert an electric signal to an optic signal or opposite of it and so can be separated electrically and insulated.
	Output point	The number of point which can operate an output equipment (solenoid valve, light and motor starter etc.)
P	PLC (Programmable Logic Controller)	An abbreviation of Programmable Logic Controller. It controls timely along with a program for logic algorithm, sequential operation and arithmetic operation.
	PNP output	An output configuration which operates an output equipment by using PNP transistor. Referred to as negative common type because negative potential is applied to common wire of power supply.
	Power supply connector	A connecting part to apply power to a product.
	Power supply voltage range	A range of power supply voltage to operate a product normally.
R	Rated voltage	A optimum value of power supply voltage applied to a product. It can ensure normal operation of a product with this voltage in specified operating environment.
S	Serial transmission	A method to enable large information to be sent and received sequentially in one communication line by aligning them in line.
	Short protection	A method to protect an internal circuit from being damaged when power supply and GND terminal are shorted.
	SI unit	An abbreviation of serial interface. It sends and receives data by bit through a couple of signal lines, convert it to parallel and correspondingly control connected load. (A serial-to-parallel converting unit)
T	Terminating resistor	A resistor mounted on both ends of wiring for connecting equipment to field bus. It prevents reflection of a signal at the end and subsequent disturbance of the signal.
	Transmission delay	A time delay from when a specified input passes a reference point until when an output reaches the reference point.

Common Specifications

•EX510 series common specifications

Item	Specification
Rated voltage	24 VDC *1
Allowable instantaneous electrical stop	1 msec. or less
Enclosure	IP20
Applicable standard	UL/CSA, CE/UKCA marked
Withstand voltage	500 VAC 1 minute (between FG and external terminal block)
Insulation resistance	10 MΩ or more (500 VDC is given between FG and external terminal block)
Ambient temperature	Operating: -10 to 50 °C Storage: -20 to 60 °C
Ambient humidity	35 to 85%RH (No dew condensation)
Operating atmosphere	No corrosive gas

*1: When conformity to UL is required, the product should be used with a UL1310 Class 2 power supply.

EX510 GW unit

Summary of Product Parts

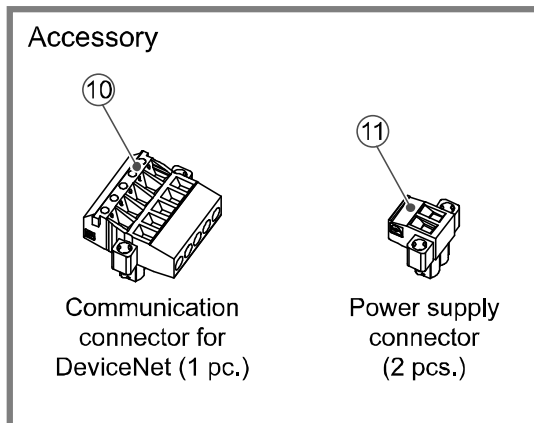
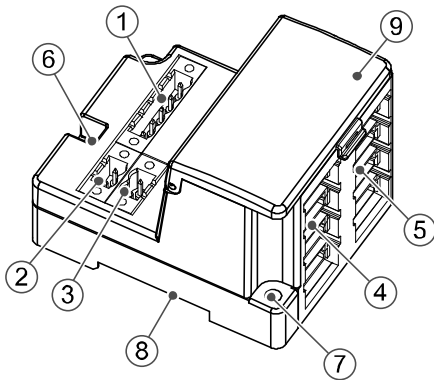

No.	Element	Description
1	Communication socket (BUS)	Connect to DeviceNet® line with a communication connector for DeviceNet® (⑩).
2	Power supply socket (PWR(V))	Supplying power for output devices such as a solenoid valve with a power supply connector (⑪).
3	Power supply socket (PWR)	Supplying power for controlling GW and for input devices such as a sensor with a power supply connector (⑪).
4	GW unit side branch connector (for input)	Connecting an Input unit etc. by using branch cables (EX510-FC##).
5	GW unit side branch connector (for output)	Connecting an SI unit (manifold valve) etc. by using branch cables (EX510-FC##).
6	Ground terminal (FG)	Used for grounding.
7	Mounting hole	Used when an unit is mounted with two M4 screws.
8	DIN rail mounting slot	Used when an unit is mounted to DIN rail.
9	Display/switch setting part	Sets up the switch on such as LED display and address, I/O points.

Mounting and Installation

■ Installation

● Screw installation

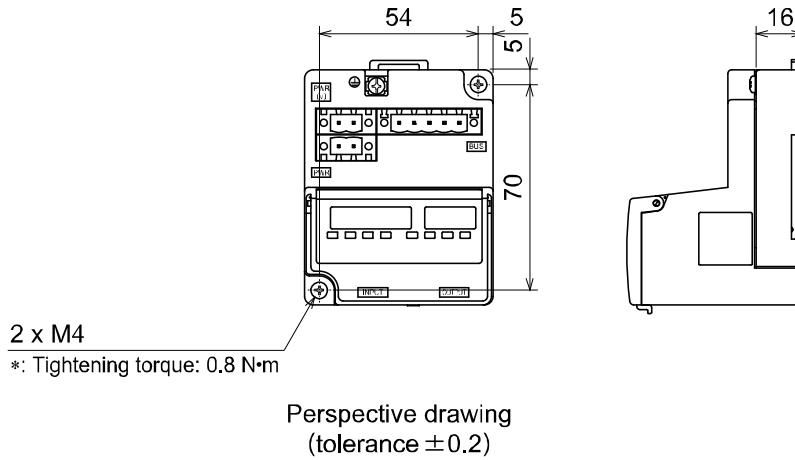

● DIN rail installation

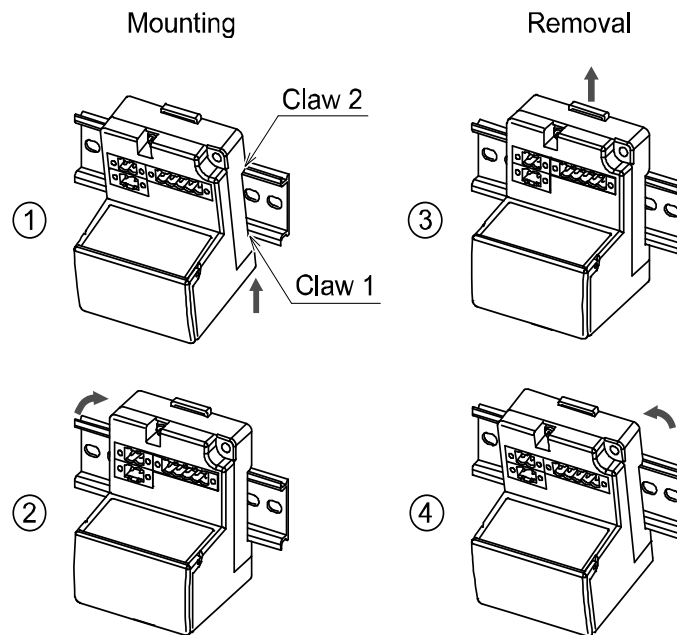

Put claw 1 of the body under DIN rail and push it upward. Push down Claw 2 to the opposite rail until the claw clicks securely on to rail. (Mounting procedure ① and ②)

For removing, lever up the DIN rail fixing plate of the body with a flat blade screwdriver, and remove it by tilting Claw 2 side forward. (Removal procedure ③ and ④)

■ Wiring

● Internal circuit and wiring

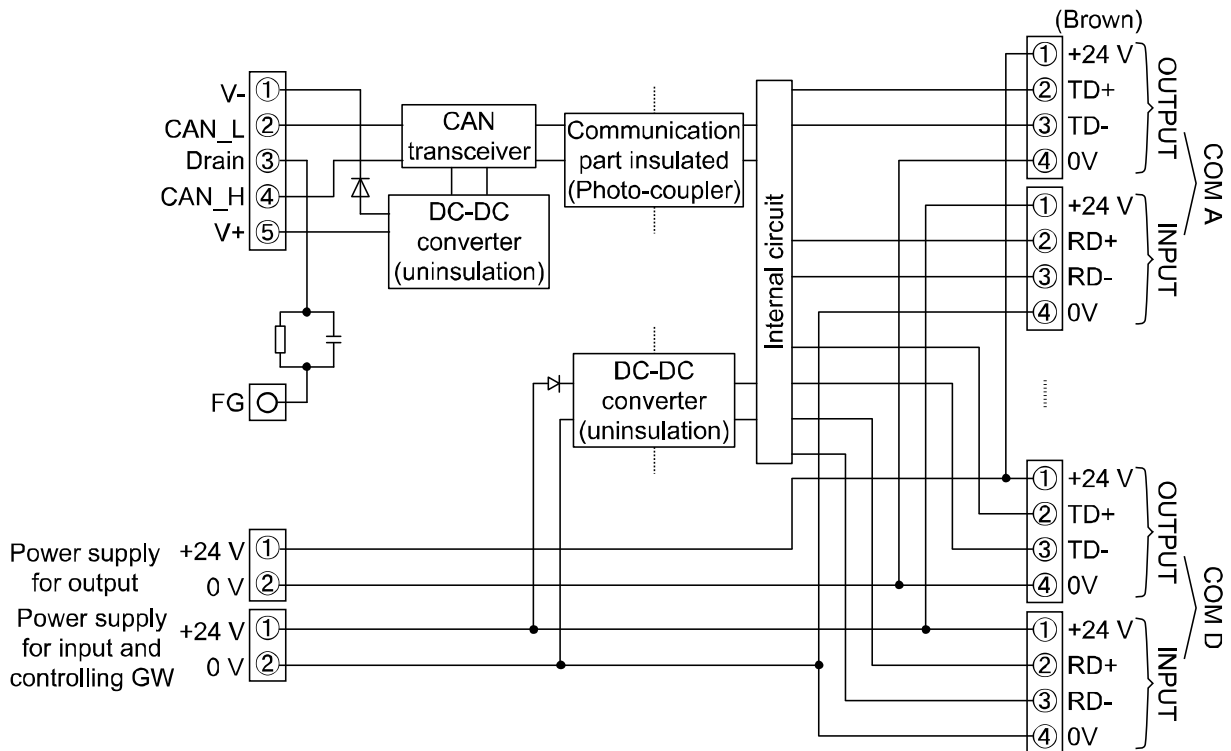

The wirings are described in the following order.

1. Communication wiring: Connection with DeviceNet®.



2. Power supply wiring: Connections of power supplies for output and input devices and controlling GW.



3. Branch wiring: Connection from GW unit to SI unit or Input unit.

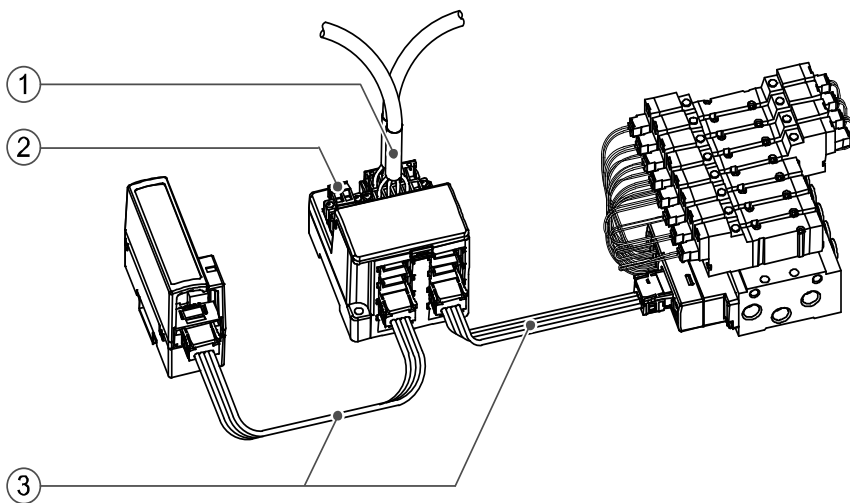

1. Communication wiring

The method to connect a DeviceNet® detected cable and a GW unit DeviceNet® communication connector is shown below.

Connecting cable

- Make sure to connect the signal cables to designated pins (Refer to Fig. 1).
The DeviceNet® communication connector is suitable for use with wire sizes from AWG24 to 12 (0.2 mm² to 2.5 mm²).
Tighten the wiring screws (M3 slotted head screws) firmly with a tightening torque of 0.5 to 0.6 N·m.
- Make sure to connect "terminal resistor" between "CAN_H"- "CAN_L" to the units at the both ends of the system. Terminating resistor is 121 Ω ±1%, 1/4 W (Refer to Fig. 2).
- Refer to Fig. 3 about how to connect to the unit.
Tighten the connector fixing screws (M2.5 slotted head screws) firmly with a tightening torque of 0.2 to 0.3 N·m.

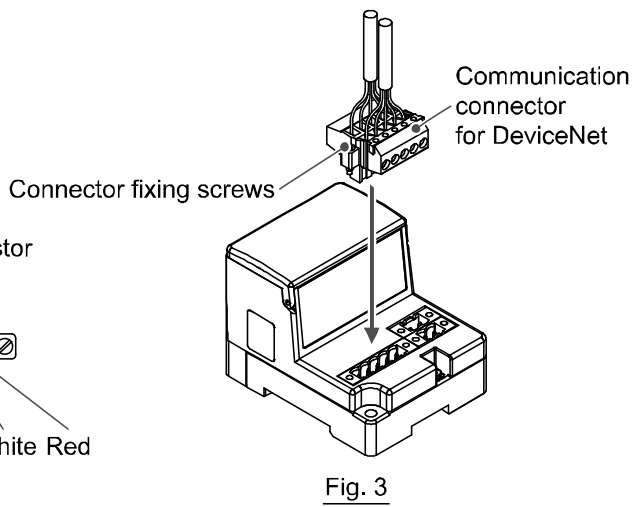
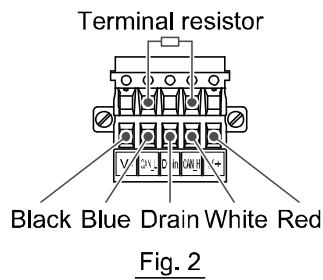
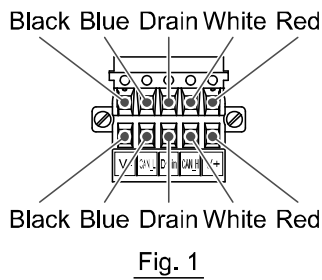

2. Power supply wiring

Connect power supply wiring to the two power supply 2-pin connectors. Power supply consists of 2 systems, but they it can be used with both of single power supply and separate power supplies. Also, other units do not need individual power supply. Make sure of connection with the designated pin. The power supply connector is suitable for use with wire sizes from AWG24 to 12 (0.2 mm² to 2.5 mm²). The tightening torque is 0.5 to 0.6 N•m.

Refer to Fig. 4 about how to connecting. When SI unit etc. (EX510-S#0#) is used besides the external power supply type Output unit, it is necessary to supply power for output to the GW unit and the Output unit.

A. For separate power supply use

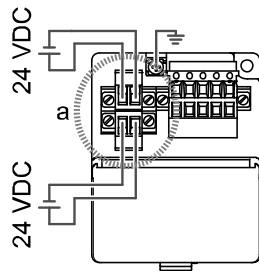

B. For single power supply use

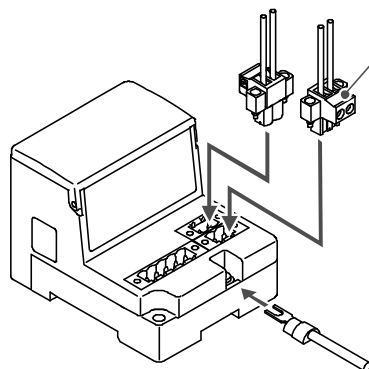
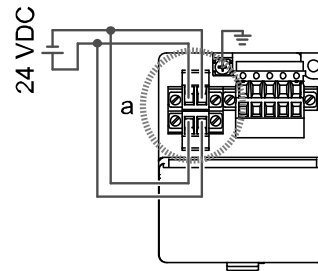

Power supply zonnector

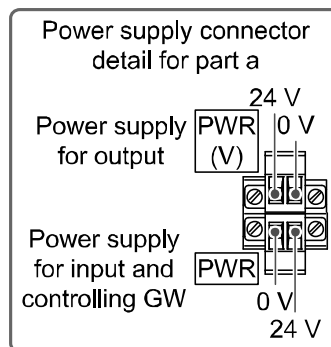

Fig. 4

NOTE

Ground the FG terminal.

3. Branch wiring

Each unit is wired with a branch cable, and connected with a branch connector.
Two branch connectors are attached to each of SI unit, Input unit and Output unit.

Pressure welding for branch connector

The method of pressure welding for branch connector is explained.

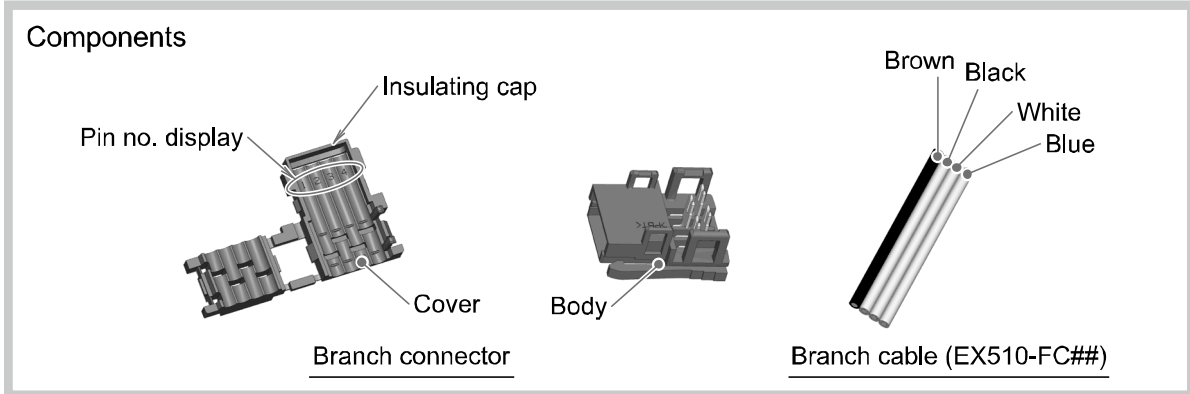

Working procedure

① Set a branch cable to the cover.

- (1) Set the brown wire of the branch cable so that it comes to the pin #1.
(2) Meet the cable end to the insulating cap at the cover.

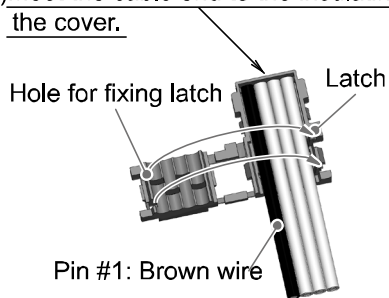

- (3) Fold the cover so that the branch cable can be put between the cover.
(4) Fix the latch tip by inserting to a hole for fixing latch.

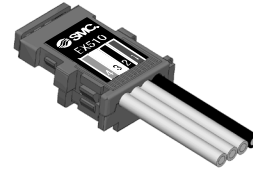

*: Check the color of wire written on a branch connector and the color of branch cable are same.

- ② Fix to the body tentatively
Fit 4 latches on the body to 4 ditches on the cover, and press them until the latch engages to the level 1.

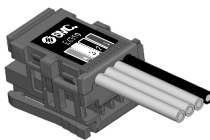

- ③ Press
Press the cover to the body with plier etc.

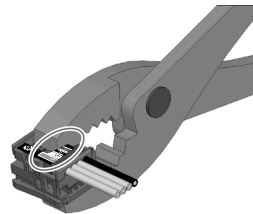

- ④ Confirmation
It is completed with a check on 4 latches engaging

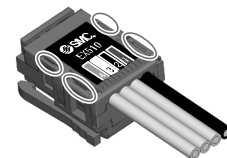

Wiring of branch cables

How to connect branch cable is shown below.

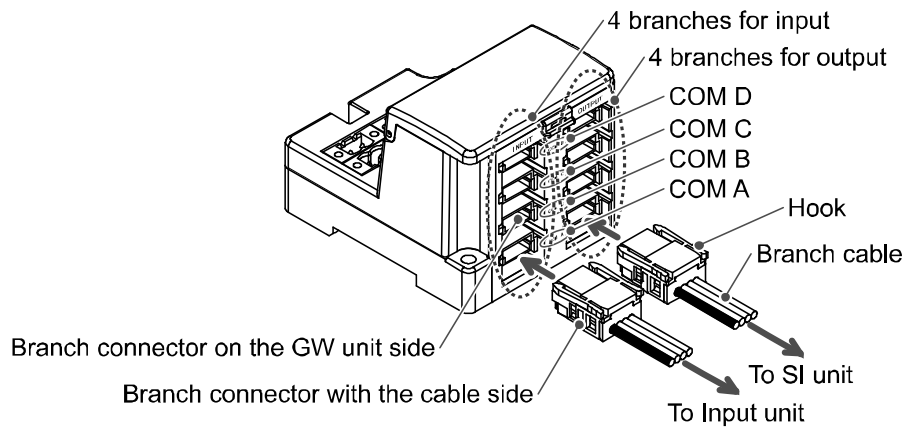

Connect the branch connectors for GW unit in order from the bottom one (COM A, B, C, and D).

NOTE

1. Select a branch cable length suitable to avoid stress being applied to the branch connector and cable, and provide sufficient cable length for maintenance.
2. Do not pull the branch connector and branch cable after wiring. There is a risk of damage.
3. Do not open and close the branch connector hook repeatedly. There is a risk of damage.
4. Cut the branch cable and replace the branch connector when the branch connector hook is broken or no longer functions.
5. Use SMC branch connector (product No.: EX510-LC1) and branch cable (product No.: EX510-FC##). Usage of other branch connector or cable is out of the applicable range of product guarantee.

Setting

•Display for setting

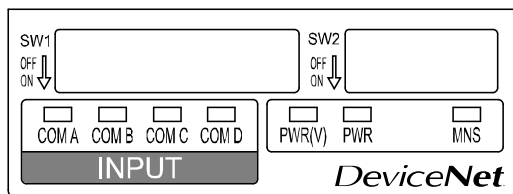

Display	Contents
PWR(V)	The power for output is supplied at specified voltage: Lights up The power for output is not supplied at specified voltage: Goes off
PWR	The power for DeviceNet® is supplied: Lights up The power for DeviceNet® is not supplied: Goes off
MNS	Power off, off line, or duplicate check MAC ID: Lights off Waiting for I/O connection (online): Green flashing I/O connection completed (online): Green lights up I/O connection · time out (Light degree of communication error): Red flashing MAC ID duplicate error, or BUS OFF error: Red lights up (Heavy degree of communication error)
COM A	COM A is receiving data: Lights up *2 COM A is having no data to receive: Goes off
COM B	COM B is receiving data: Lights up *2 COM B is having no data to receive: Goes off
COM C	COM C is receiving data: Lights up *2 COM C is having no data to receive: Goes off
COM D	COM D is receiving data: Lights up *2 COM D is having no data to receive: Goes off

*: Only when Input is connected and communicated normally.
COM A-D LED does not light up if the port is not set to be "used" by input point setting.

•Switch setting

NOTE

1. Open the cover, and set DIP switch with a flat blade driver, etc.
2. Make sure that switch setting is performed with power supply turned off.
3. Be sure to perform this setting of the switch before use.

1. Setting of MAC ID • Communication speed • HOLD/CLR • HW/SW mode (SW1)

Setting of address is performed with SW1.

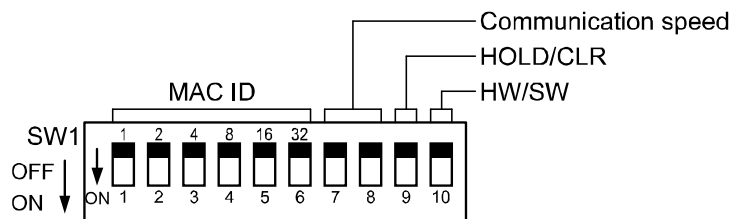

•**MAC ID setting (Switch No.1 to 6)**

All setting are turned ON at shipment and the MAC ID is set to 63.

Make sure to set the MAC ID in the range of 0 to 63.

MAC ID	1 (No.1)	2 (No.2)	4 (No.3)	8 (No.4)	16 (No.5)	32 (No.6)
0	OFF	OFF	OFF	OFF	OFF	OFF
1	ON	OFF	OFF	OFF	OFF	OFF
2	OFF	ON	OFF	OFF	OFF	OFF
3	ON	ON	OFF	OFF	OFF	OFF
:	:	:	:	:	:	:
10	OFF	ON	OFF	ON	OFF	OFF
11	ON	ON	OFF	ON	OFF	OFF
:	:	:	:	:	:	:
62	OFF	ON	ON	ON	ON	ON
63	ON	ON	ON	ON	ON	ON

•**Communication speed setting (Switch No.7 to 8)**

Make sure to set the communication speed in the range as follows.

All setting are turned OFF at shipment, set to 125 kbps.

Communication speed	No.7	No.8
125 kbps	OFF	OFF
250 kbps	ON	OFF
500 kbps	OFF	ON
-	ON	ON

•**HOLD/CLR setting (Switch No.9)**

The setting is as follows.

The setting at shipment is turned OFF, set to CLR.

HOLD/CLR	No.9	Function
CLR	OFF	Output is cleared when an error occurs.
HOLD	ON	Output is held when an error occurs.

●HW/SW mode setting (Switch No.10)

The setting is as follows.

The setting at shipment is turned OFF, set to HW mode.

Mode	No.10	Function
HW	OFF	Set MAC ID and communication speed with SW1 to 8.
SW	ON	MAC ID and communication speed are set by network. *: No.1 to 8 (SW1) are ignored.

2. Flexible setting of I/O point (SW2)

I/O point can be changed with SW2.

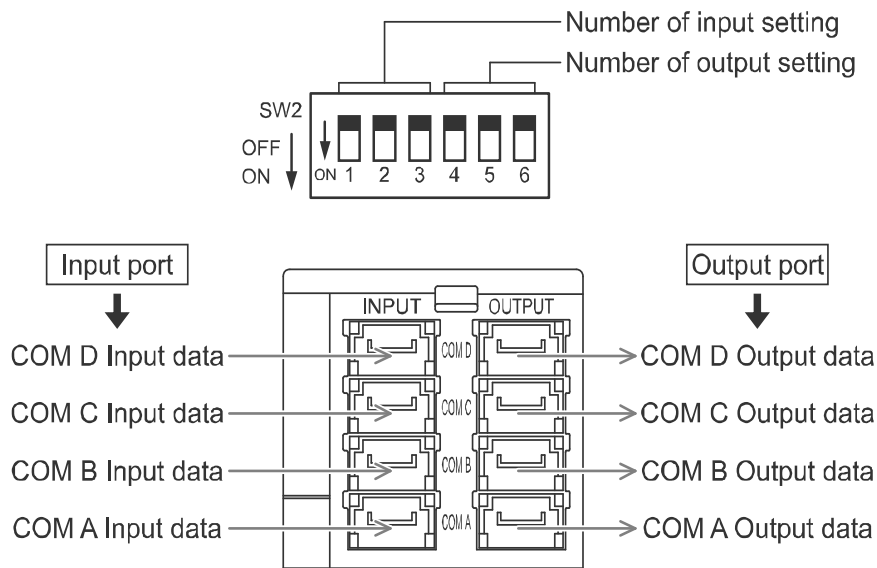

●Input setting (Switch No.1 to 3)

The setting at shipment is turned OFF, set to 64.

No.1	No.2	No.3	Input point	COM A	COM B	COM C	COM D	
OFF	OFF	OFF	64	16	16	16	16	
OFF	OFF	ON	0	-	-	-	-	
OFF	ON	OFF	16	8	8	-	-	
OFF	ON	ON	16	16	-	-	-	
ON	OFF	OFF	32	8	8	8	8	
ON	OFF	ON	32	16	16	-	-	
ON	ON	OFF	Reserve					
ON	ON	ON						

*: It cannot be set to 0 simultaneously for input and output point.

●Output setting (Switch No.4 to 6)

The setting at shipment is turned OFF, set to 64.

No.4	No.5	No.6	Output point	COM A	COM B	COM C	COM D		
OFF	OFF	OFF	64	16	16	16	16		
OFF	OFF	ON	0	-	-	-	-		
OFF	ON	OFF	16	8	8	-	-		
OFF	ON	ON	16	16	16	-	-		
ON	OFF	OFF	32	8	8	8	8		
ON	OFF	ON	32	16	16	-	-		
ON	ON	OFF	Reserve						
ON	ON	ON							

*: It cannot be set to 0 simultaneously for input and output point.

3. Setting I/O Memory map

GW unit occupies memory area as follows according to the number of I/O point set up on the front page.

Ex.) Input point: 64, Output point: 64 (Setting at shipment)

In case of the input data, the sensor signal data of the Input unit which was connected with the COM A port, occupies "Word (a)" of the input area.

If a sensor signal is stored in the "0 bit" of the Input unit, it becomes like the figure below.

In the same way, in the case of the output data, the contents displayed in "Word (c)" of the output area.

●Memory map of input data

Input area	Branch connector (INPUT)	Data (2 byte)			
		MSB		LSB	
		15	8	7	0
Word (a)	COM A	byte (b+1)		byte (b)	
Word (a+1)	COM B	byte (b+3)		byte (b+2)	
Word (a+2)	COM C	byte (b+5)		byte (b+4)	
Word (a+3)	COM D	byte (b+7)		byte (b+6)	
:	:				

(a, b=0 to)

●Memory map of output data

Output area	Branch connector (OUTPUT)	Data (2 byte)			
		MSB		LSB	
		15	8	7	0
Word(c)	COM A	byte (d+1)		byte (b)	
Word(c+1)	COM B	byte (d+3)		byte (b+2)	
Word(c+2)	COM C	byte (d+5)		byte (b+4)	
Word(c+3)	COM D	byte (d+7)		byte (b+6)	
:	:				

(c, d=0 to)

NOTE

Read carefully the user manual of PLC which is used as a master.

The method of PLC setup, reading from or writing to memory differ from one PLC manufacturer to another.

Specification

■ Specifications

● Basic specifications

Rated voltage	24 VDC *		
Power supply voltage	Power supply for input and controlling: 24 VDC±10% Power supply for output: 24 VDC+10%/-5% (Warning for voltage drop is given at approx. 20 V)		
Rated current	Power supply for input and controlling: Max. 4.1 A <table border="1" style="margin-left: 20px;"> <tr> <td>Inside GW unit: 0.1 A</td> </tr> <tr> <td>Input unit: 4 A</td> </tr> </table> Power supply for output: Max. 6 A	Inside GW unit: 0.1 A	Input unit: 4 A
Inside GW unit: 0.1 A			
Input unit: 4 A			
Input/Output point	Input point: Max. 64/Output point: Max. 64 (Changeable by switch settings)		
Weight	160 g (including accessories)		

*: When conformity to UL is required, the product should be used with a UL1310 Class 2 power supply.

● Higher-level bus

Compatible system	DeviceNet® Release 2.0
Number of station occupied	Group2 Only Server
MAC ID setting	0 to 63
Device information	Vender code: 7 (SMC Corp.) Product type: 12 Product code: 100
Applicable message	Duplicate MAC ID Check Message Group2 Only Unconnected Explicit Message Explicit Message Poll/I/O Message
I/O message size	Input: Max. 8 byte, Output: Max. 8 byte (Changeable by switch settings)

Communication speed		125 kbps	250 kbps	500 kbps
Max. length of Network	Thick cable	500 m or less	250 m or less	100 m or less
	Thin cable	100m or less		
Total extended cable length		156 m or less	78 m or less	39 m or less

*: Max. extended cable length is 6 m

● Lower-level bus

Number of branches for input/output	4 branches for input, 4 branches for output
Communication type	Communication protocol: dedicated for SMC Communication speed: 750 kbps
Current for input branch *	Max. 1 A per branch
Current for output branch	Max. 1.5 A per branch
Branch cable length	Within 20 m (Refer to diagram right for details.)

*: Maximum value in total of current consumption and load current of connected input equipments.

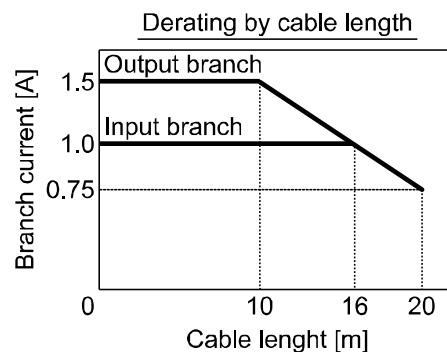

■Dimensions

- GW unit (EX510-GDN1)

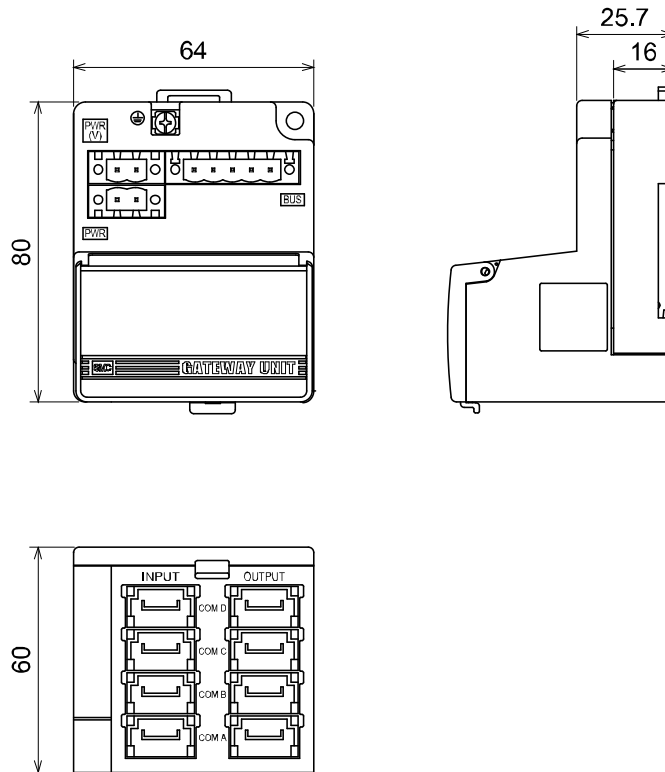

SI unit

Summary of Product Parts

SI unit is the unit to be combined with manifold solenoid valves to communicate with GW unit. It can be used with a plug lead type and plug in type solenoid valves.

Single solenoid valve can be operated by using empty ports. (Only for EX510-S □01 □)

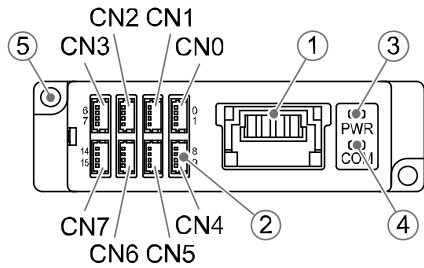

Accessory

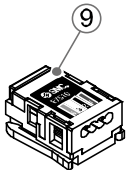

Branch connector
(2 pcs.) (EX510-LC1)

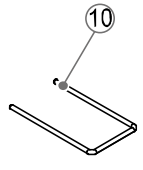

Connector lock pin
(1 pc.) *

*: It is integrated into the body of the unit for EX510-S#02#.

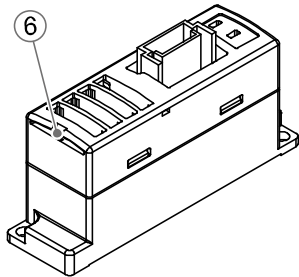

EX510-S#01

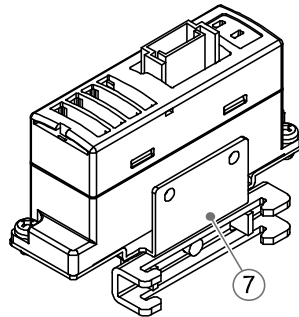

EX510-S#01B

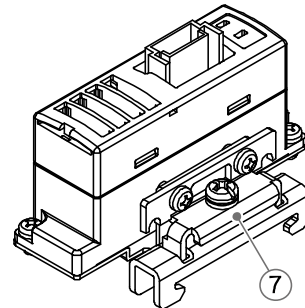

EX510-S#01A

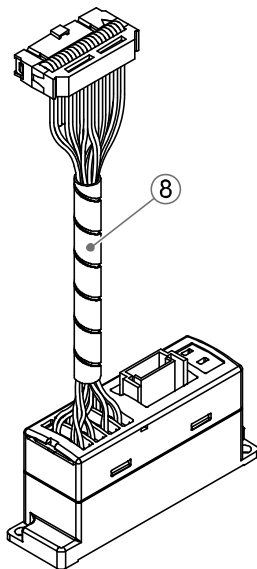

EX510-S#02

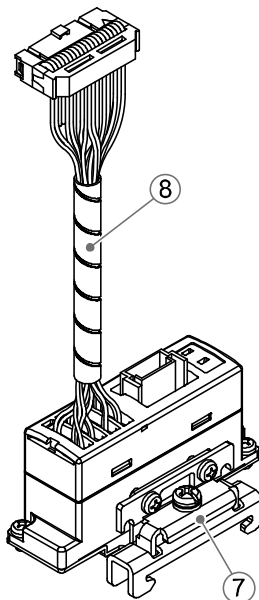

EX510-S#02A

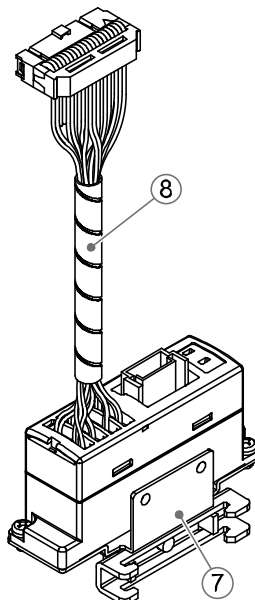

EX510-S#02B

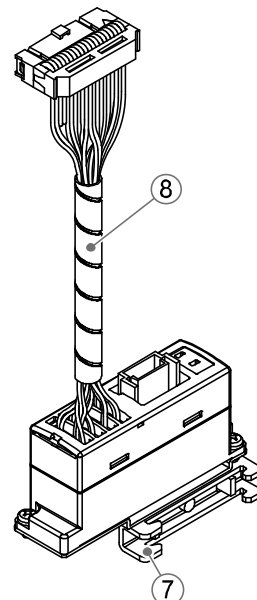

EX510-S#02C

No.	Element	Description
1	Branch connector on the SI unit side	Used to crimp branch connector (⑨) into branch cable (EX510-FC##) and connected them to GW unit.
2	Load mounting connector	Connecting output equipment such as solenoid valve.
3	Power supply LED	Lights up: Power ON (Normal) Goes off: Power OFF
4	Communication LED	Lights up: Data received Goes off: No data received
5	Mounting hole	Used to mount the unit with two M3 screws.
6	Connector locking pin inserted hole	Receiving connector locking pin (⑩).
7	Mounting bracket	Possible to mount on DIN rail.
8	Adapter cable assembly	Connects a plug-in valve manifold. (Only for EX510-S#02#)

*: Only mounting direction of the SI unit to the mounting bracket is different between EX510-S###A and EX510-S###B. Mounting direction can be changed from horizontal to vertical by changing the screws which construct the mounting bracket. Mounting direction of the EX510-S#02C cannot be changed to vertical as the its mounting bracket is exclusive for horizontal mounting.

Mounting and Installation

■ Installation

Each SI unit is mounted and removed as shown on the following figure.

● Mounted by screw

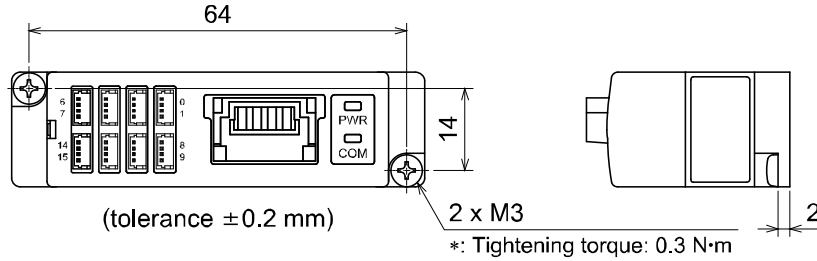

● Mounted on DIN rail

Vertical mounting

EX510-S#01A
EX510-S#02A

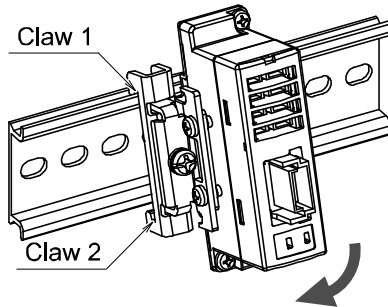

Horizontal mounting

EX510-S#01B
EX510-S#02B, C

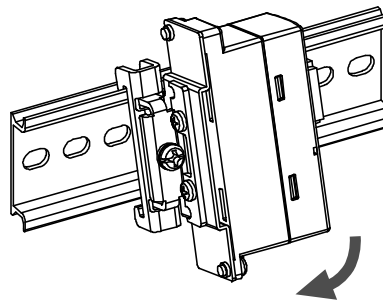

1, Hook claw 1 over the upper side and claw 2 over the low side of DIN rail respectively.

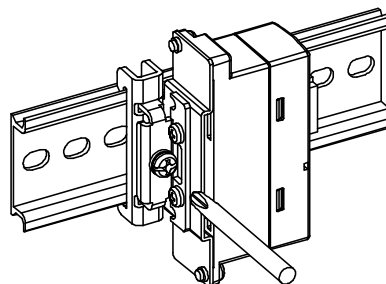
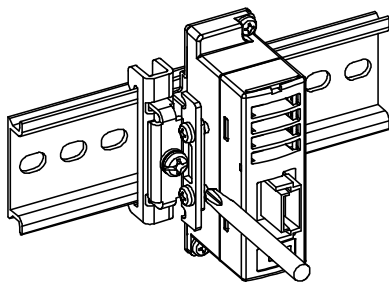

2, Tighten the screw by Phillips screw driver until DIN rail is secured. (Tightening torque: 0.6 N·m)

3, When the DIN rail is disconnected, loosen the screw and unengaged claw 2 and then claw 1 in order.

■Wiring

●Internal circuit and wiring

●EX510-S001#

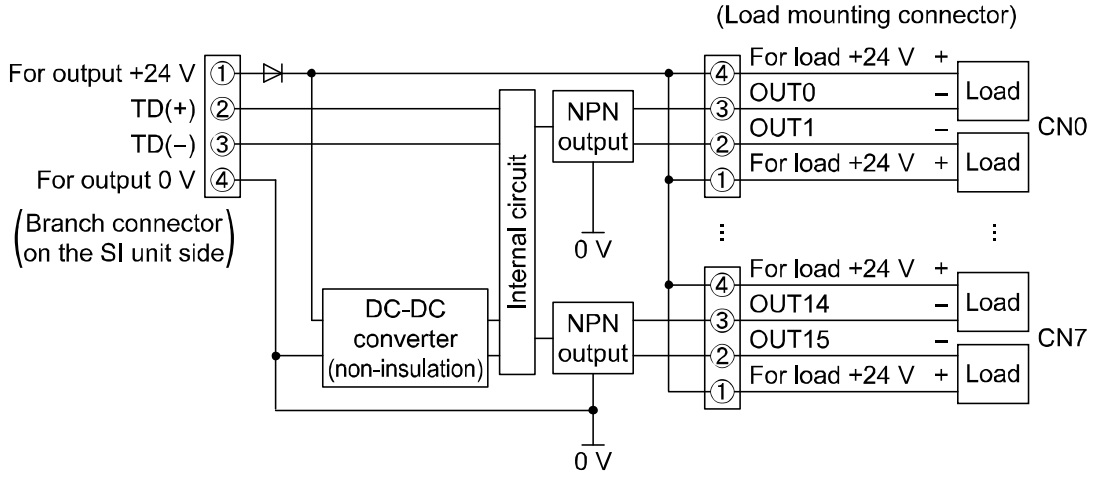

●EX510-S101#

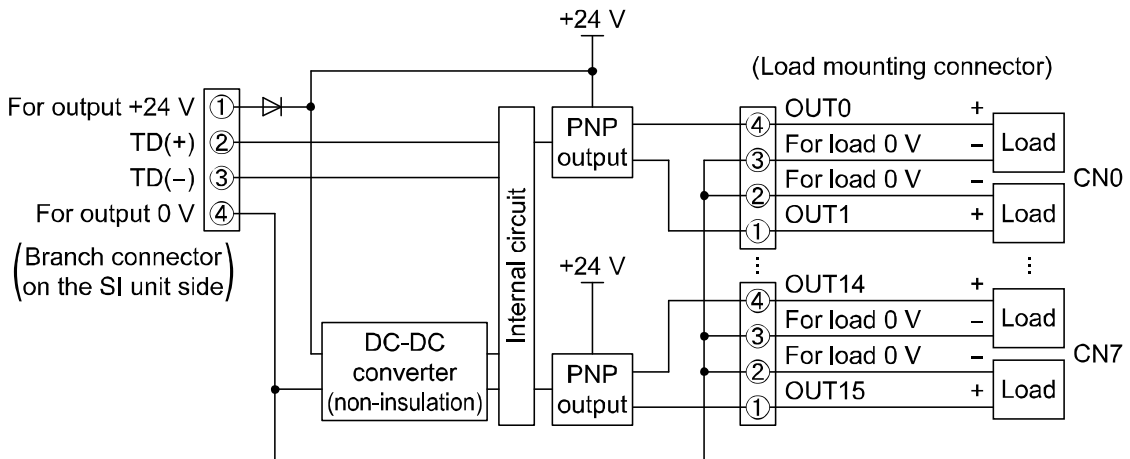

•EX510-S002#

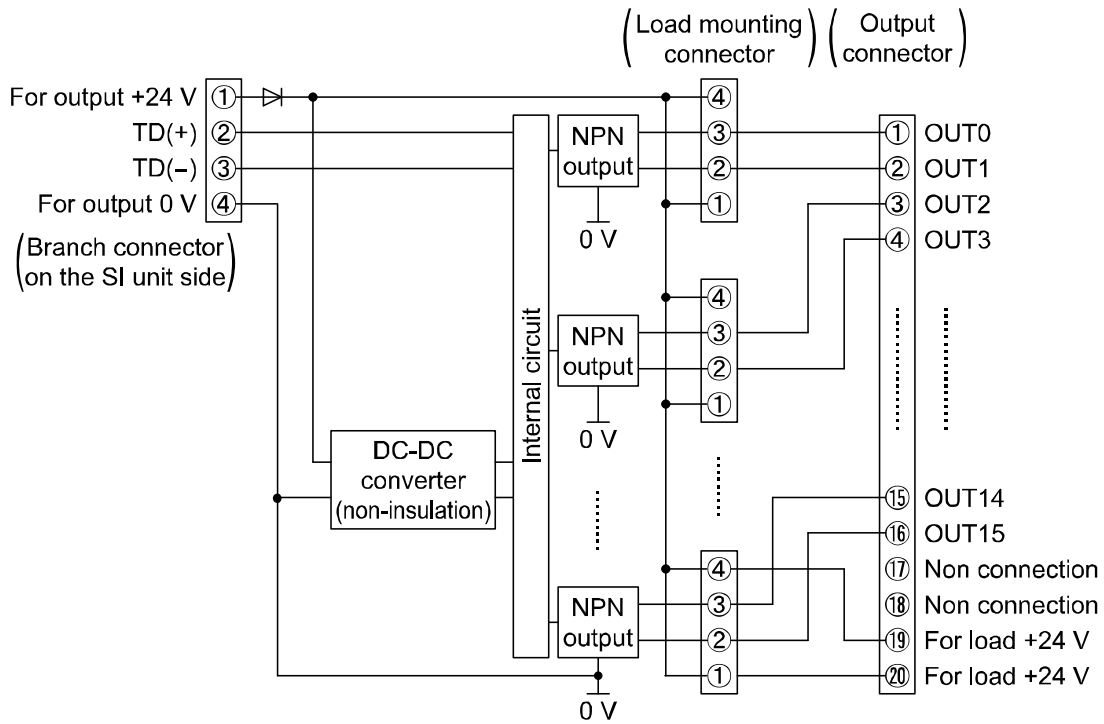

•EX510-S102#

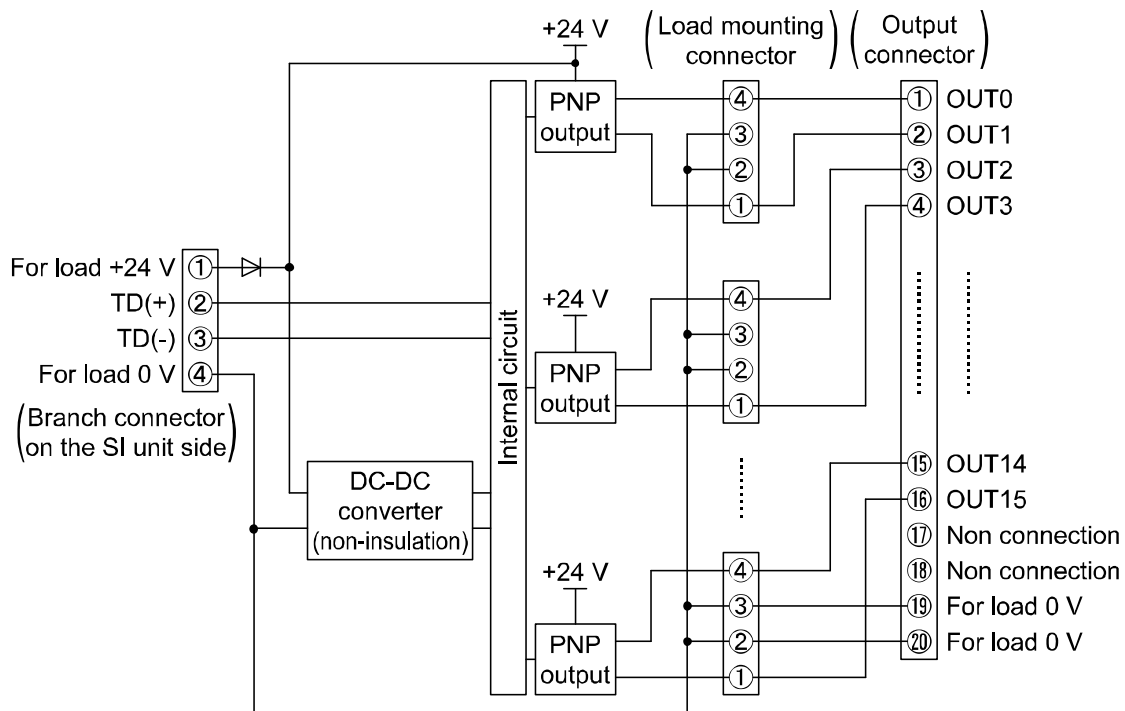

- Wiring of the branch cable and connector for connecting load
(Connector for connecting load: Applicable only to EX510-S#01#)
- Wiring of branch cables and load mounting connector are shown below.
- Insert load mounting connector with pinsette. After insertion at all load mounting connectors is completed, insert connector locking pin. The output no. of each load mounting connector can be found on the below.

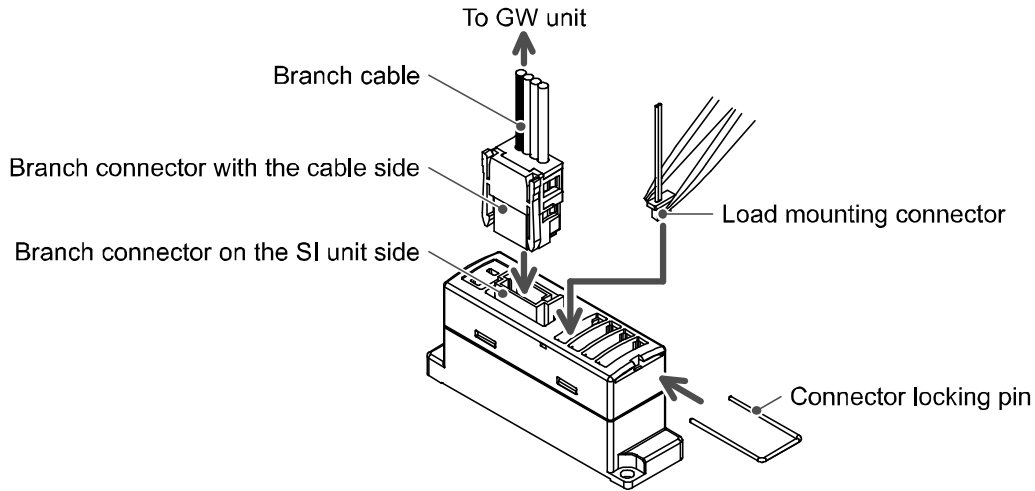

*: For crimping of a branch connector, refer to page 18.

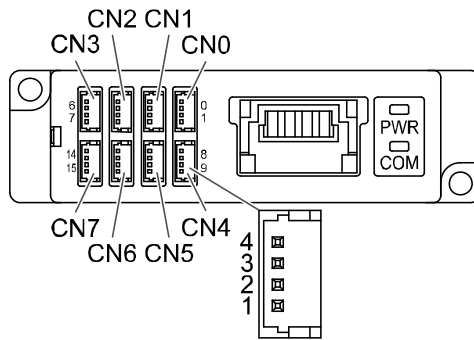

•Load connecting connector pin assignment (EX510-S#01#)

•EX510-S001#

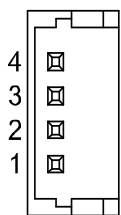

No.	Name	Function							
		CN0	CN1	CN2	CN3	CN4	CN5	CN6	CN7
4	COM	Load actuating common (+)							
3	Output (n)	OUT0	OUT2	OUT4	OUT6	OUT8	OUT10	OUT12	OUT14
2	Output (n+1)	OUT1	OUT3	OUT5	OUT7	OUT9	OUT11	OUT13	OUT15
1	COM	Load actuating common (+)							

•EX510-S101#

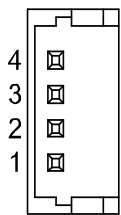

No.	Name	Function							
		CN0	CN1	CN2	CN3	CN4	CN5	CN6	CN7
4	Output (n)	OUT0	OUT2	OUT4	OUT6	OUT8	OUT10	OUT12	OUT14
3	COM	Load actuating common (-)							
2	COM	Load actuating common (-)							
1	Output (n+1)	OUT1	OUT3	OUT5	OUT7	OUT9	OUT11	OUT13	OUT15

●Output connector (MIL20-pin) pin assignment (EX510-S#02#)

●EX510-S002#

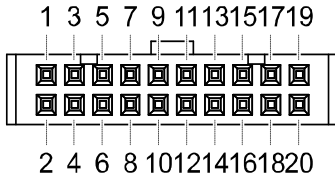

Terminal No.	1	3	5	7	9	11	13	15	17	19
Output No.	0	2	4	6	8	10	12	14	-	24 V
Type	-	-	-	-	-	-	-	-	-	+COM
Terminal No.	2	4	6	8	10	12	14	16	18	20
Output No.	1	3	5	7	9	11	13	15	-	24 V
Type	-	-	-	-	-	-	-	-	-	+COM

●EX510-S102#

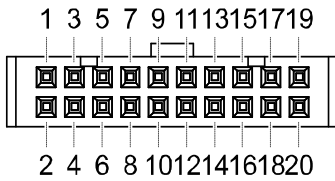

Terminal No.	1	3	5	7	9	11	13	15	17	19
Output No.	0	2	4	6	8	10	12	14	-	0 V
Type	+	+	+	+	+	+	+	+	-	-COM
Terminal No.	2	4	6	8	10	12	14	16	18	20
Output No.	1	3	5	7	9	11	13	15	-	0 V
Type	+	+	+	+	+	+	+	+	-	-COM

*: Only a flat cable type manifold (P kit) can be connected to EX510-S#02#. It cannot be connected to PCW type (G/J kit) according to the different pin assign.

●Use of remaining output (Only for EX510-S#01#)

Remaining output of SI unit can be used by using a cable assembly for output. (Refer to the figure below.) Refer to "SI unit specifications" on page 33 for the load current restriction of SI unit.

Power consumption of each valve series is shown in the table below. Refer to the catalog of each valve series for detail.

Valve series	Power consumption
SY3000/5000/7000/9000	Standard: 0.4 W (approx. 17 mA) With power saving circuit: 0.1 W (approx. 4 mA)
SYJ3000/5000/7000	Standard: 0.4 W (approx. 17 mA) With power saving circuit: 0.1 W (approx. 4 mA)
VQZ1000/2000/3000	Standard: 1.0 W (approx. 42 mA) Low wattage: 0.5 W (approx. 21 mA)

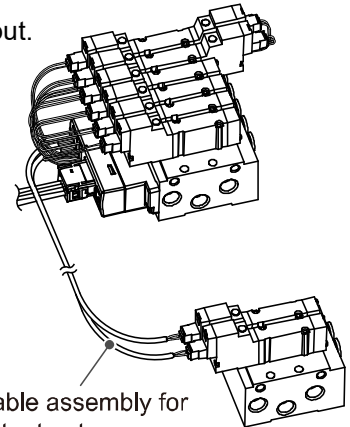

Cable assembly for output entry (EX510-V###)

Refer to "Wiring of the branch cable and connector for connecting load" on page 31 for how to wire the cable assembly for output.

NOTE

Do not pull the cable assembly for output strongly. It can cause defective connection or broken wire.

Setting

•Setting of display

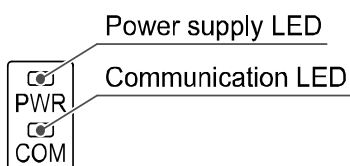

Display	Contents
Power supply LED	Lights up: The power for output is supplied at specified voltage. Goes off: The power for output is not supplied at specified voltage.
Communication LED	Lights up: Data is being received from a GW unit Goes off: No data is being received.

Specification

■Specifications

•SI unit specifications

Item	Specification	
Model No.	EX510-S001#, EX510-S002#	EX510-S101#, EX510-S102#
Output type	NPN output (Sink type)	PNP output (source type)
Number of output points	16 points	
Rated load voltage	24 VDC *	
Max. load current	Meet the three following conditions: (1) 1 point: 0.25 A or less (2) 1 unit: 1.4 A or less (3) Total current of OUT0 to OUT7: 1 A or less, Total current of OUT8 to OUT15: 1 A or less	
Protection	Built-in protection circuit for short circuit	
Current consumption	50 mA or less (inside of SI unit)	
Weight	EX510-S#01: 40 g/EX510-S#01A, B: 80 g/EX510-S#02: 50 g EX510-S#02A, B, C: 90 g (including accessories)	

*: When conformity to UL is required, the product should be used with a UL1310 Class 2 power supply.

•Applicable solenoid valve series

The following manifold valve can be used for EX510 series.

•Non-plug in type

Valve series	Model No.
SY	3000, 5000, 7000, 9000
SYJ	3000, 5000, 7000
S0700	0700
VQZ	1000, 2000, 3000

•Plug-in type

Valve series	Model No.
SJ	2000, 3000
SZ	3000
SY	3000, 5000
SQ	1000, 2000
VQ	1000, 2000

Refer to the catalogs and Operation Manual of each valve series for solenoid valve and manifold, etc.

■Dimensions

●EX510-S#01

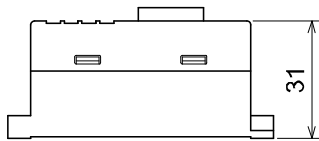
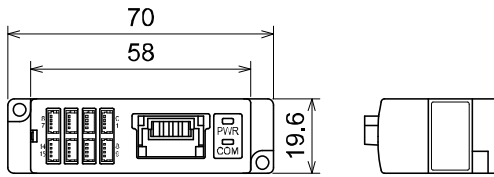

●EX510-S#01A

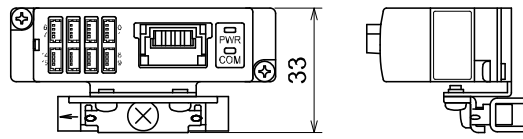

●EX510-S#01B

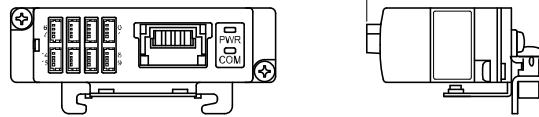

●EX510-S#02

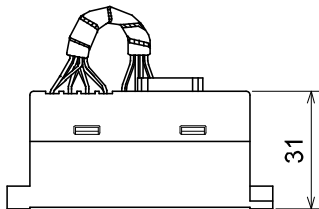
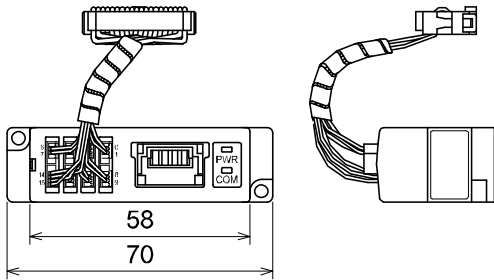

●EX510-S#02A

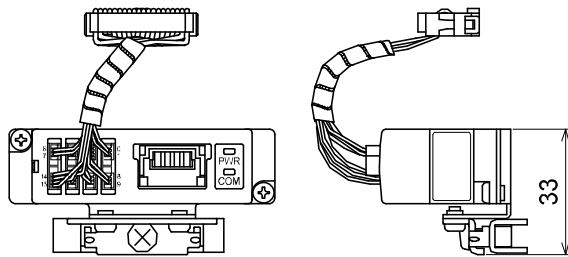

●EX510-S#02B

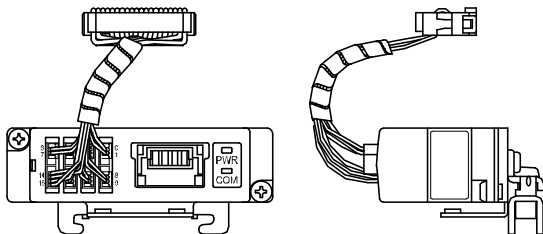

●EX510-S#02C

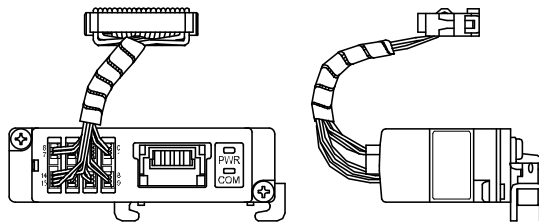

Refer to the catalogs and Operation Manual of each valve series for dimensions of the manifold valve.

Output unit

Summary of Product Parts

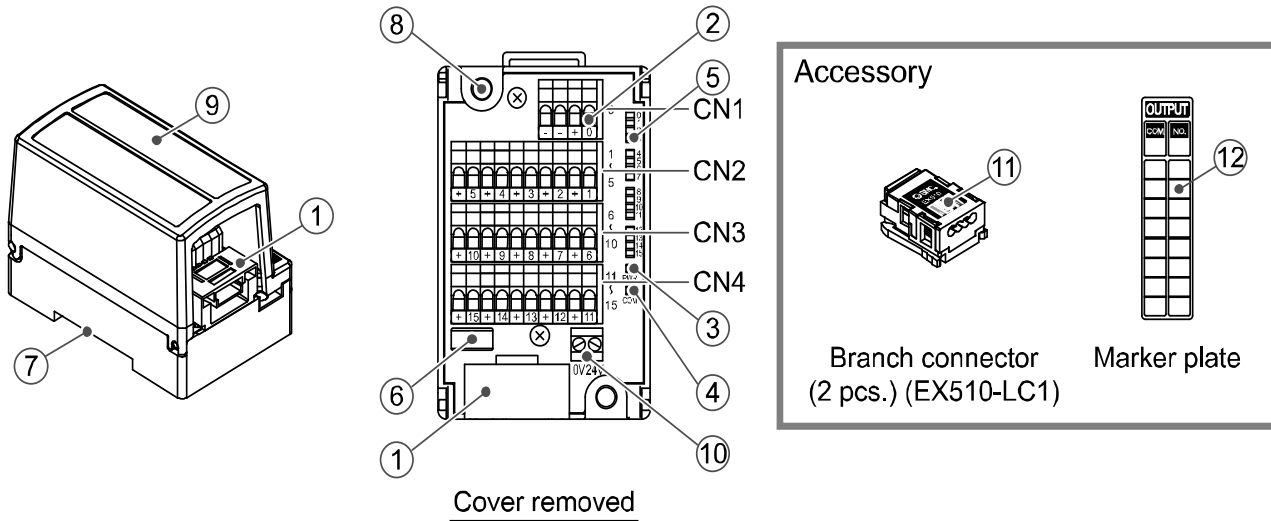

No.	Element	Description
1	Branch connector on the Output unit side	Used to crimp branch connector (⑪) into branch cable (EX510-FC##) and connected them to GW unit.
2	Output terminal block	Used to connect output load, etc.
3	Power supply LED	Lights up: Power ON (normal) Goes off: Power OFF
4	Communication LED	Lights up: Receiving data Goes off: No communication data
5	Display LED	Lights up: Output signal ON Goes off: Output signal OFF
6	Fuse	Fuse is replaceable.
7	Mounting slot	Used to mount DIN rail on the unit.
8	Mounting hole	The unit is mounted by two M4 screws.
9	Cover	Used to protect cable and provided with marker plate (⑫) on the top.
10	Terminal block for auxiliary power supply	Used to supply power for the loads. (EX510-DYN4, EX510-DYP4)

Mounting and Installation

■ Installation

- Mounted by screw

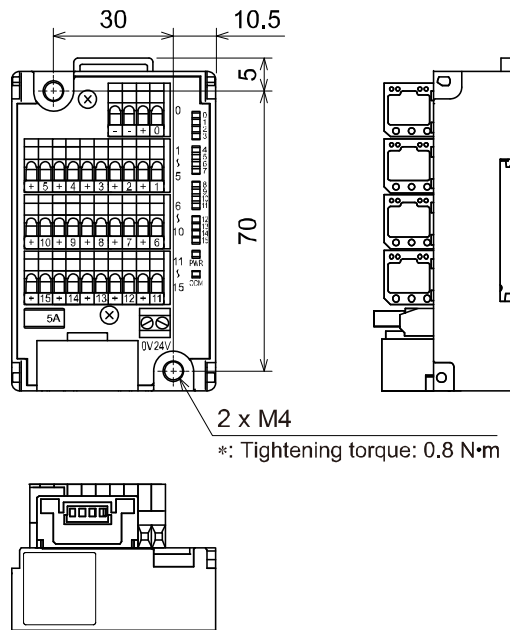

Cover removed (tolerance ± 0.2 mm)

- Mounted on DIN rail (Common for EX510-DY#1 and 2)

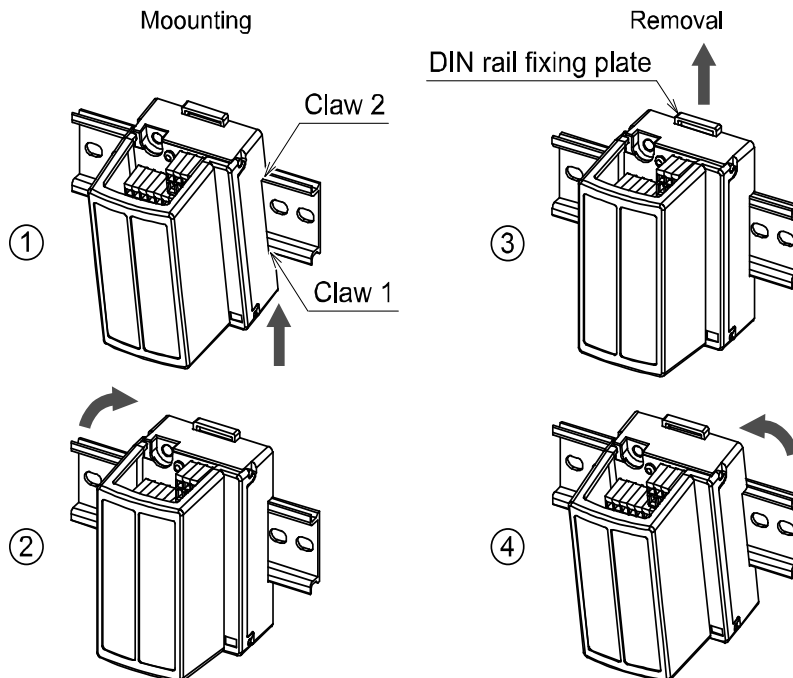

Put claw 1 at the body under DIN rail and push it upward. Push down claw 2 to the opposite rail unit the claw clicks to be set stably. (Mounting procedure ① and ②)

For removing, push up DIN rail fixing plate at the body with a flat screwdriver, and remove it by tilting claw 2 side forward. (Removal procedure ③ and ④)

■Wiring

●Internal circuit and wiring

●EX510-DYN3: Output unit for NPN (Internal power supply type)

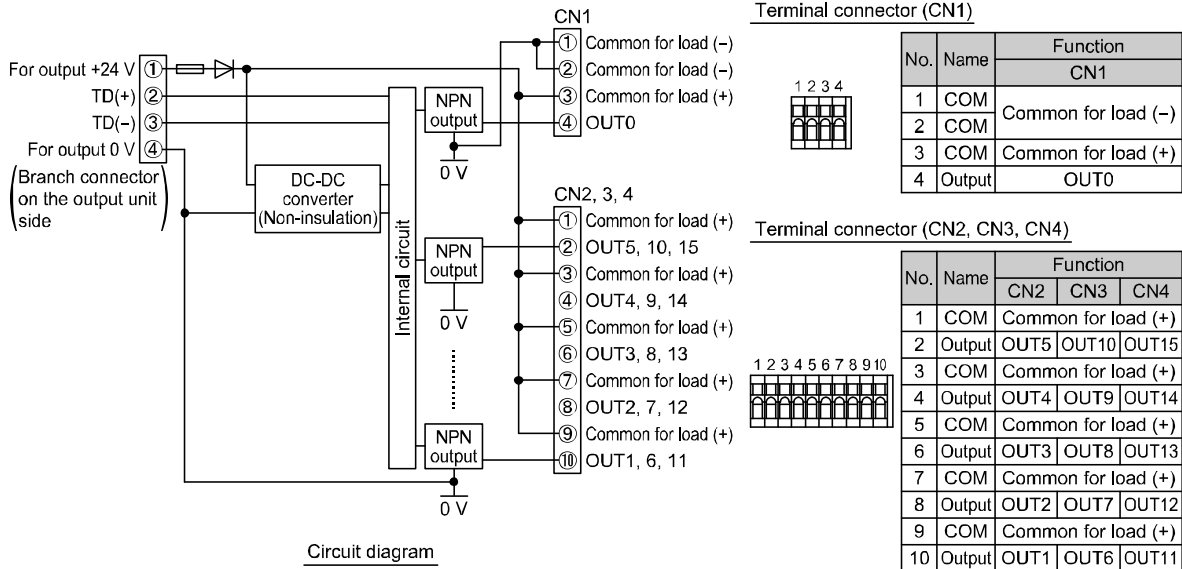

●EX510-DYN4: Output unit for NPN (Auxiliary power supply type)

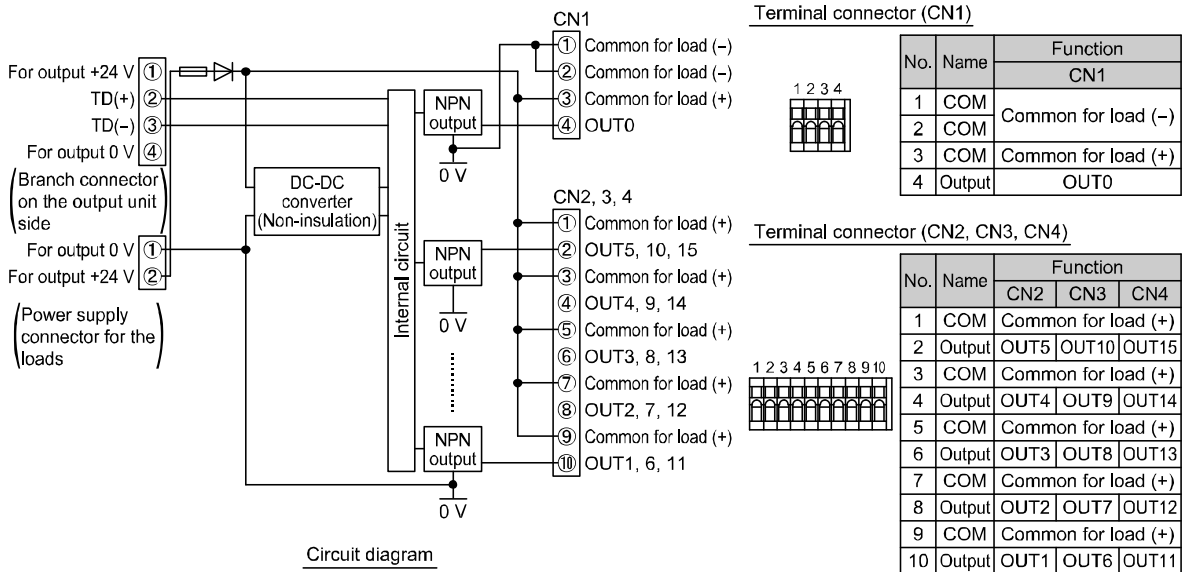

●EX510-DYP3: Output unit for PNP (Internal power supply type)

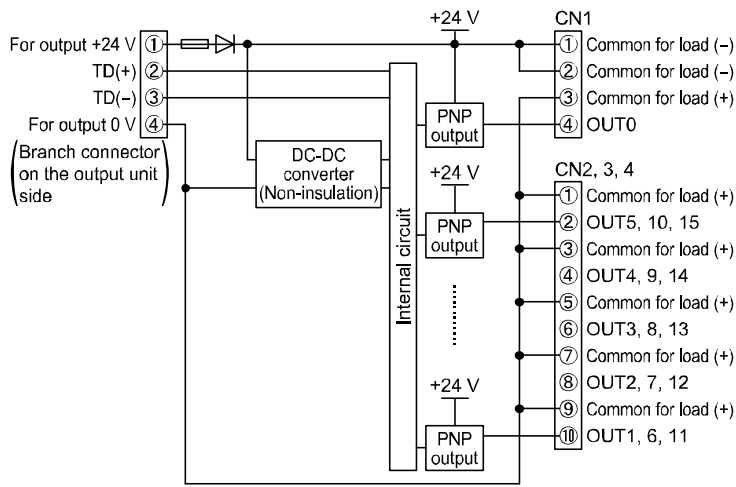

Circuit diagram

Terminal connector (CN1)



No.	Name	Function
CN1		
1	COM	Common for load (+)
2	COM	Common for load (-)
3	COM	Common for load (-)
4	Output	OUT0

Terminal connector (CN2, CN3, CN4)

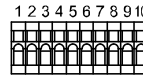

No.	Name	Function		
		CN2	CN3	CN4
1	COM	Common for load (-)		
2	Output	OUT5	OUT10	OUT15
3	COM	Common for load (-)		
4	Output	OUT4	OUT9	OUT14
5	COM	Common for load (-)		
6	Output	OUT3	OUT8	OUT13
7	COM	Common for load (-)		
8	Output	OUT2	OUT7	OUT12
9	COM	Common for load (-)		
10	Output	OUT1	OUT6	OUT11

●EX510-DYP4: Output unit for PNP (Auxiliary power supply type)

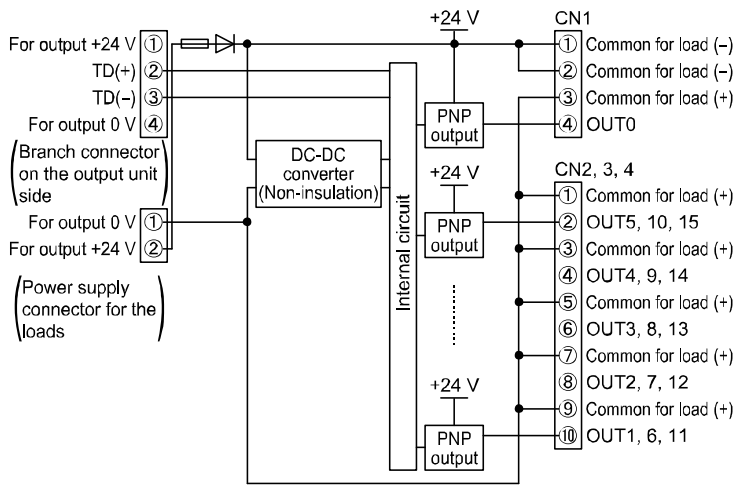

Circuit diagram

Terminal connector (CN1)



No.	Name	Function
CN1		
1	COM	Common for load (+)
2	COM	Common for load (-)
3	COM	Common for load (-)
4	Output	OUT0

Terminal connector (CN2, CN3, CN4)

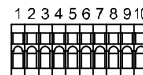

No.	Name	Function		
		CN2	CN3	CN4
1	COM	Common for load (-)		
2	Output	OUT5	OUT10	OUT15
3	COM	Common for load (-)		
4	Output	OUT4	OUT9	OUT14
5	COM	Common for load (-)		
6	Output	OUT3	OUT8	OUT13
7	COM	Common for load (-)		
8	Output	OUT2	OUT7	OUT12
9	COM	Common for load (-)		
10	Output	OUT1	OUT6	OUT11

•Wiring of the branch cable, and load electric wire and terminal block connector

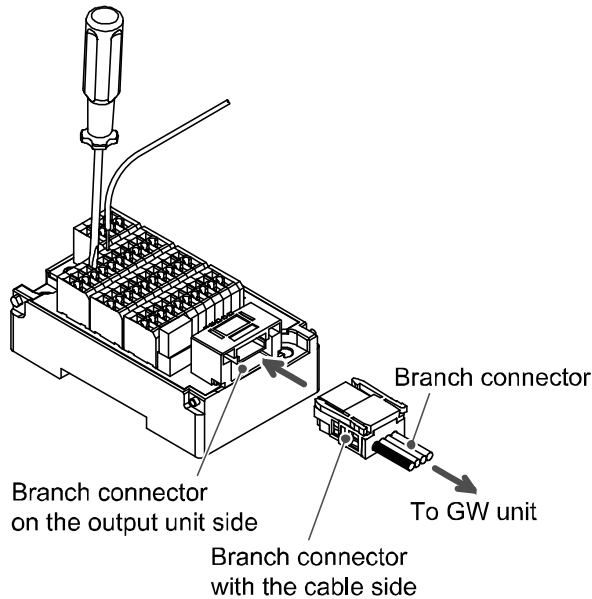

- Insert flat blade watch driver from slots on a terminal block connector to the end position.
- Hold clamping part opened with a blade of the driver.
- Insert electric wire into a clamping unit of a terminal block and pull the driver to finish wiring.
- Applicable electric wire size is 0.08 to 1.5 mm² (AWG 16 to 28).
- Wire sheath stripped length is 5 to 6 mm.
- Too long stripped length might expose conductor and cause insulation failure, and too short stripped length might get the sheath caught or make the conductor unclamped or clamped improperly resulting in contact failure or disconnection of electric wire.
- The flat blade watch driver shall have 2.5 mm x 0.4 mm blade end width and hold the clamp opened.

*: For crimping of a branch connector, refer to page 18.

The terminal block connector can be connected with the following electric wires.

- Solid wire, fine stranded wire, stranded conductor ultrasonically bonded, stranded conductor with ferrule, stranded conductor with pin terminal.

Wiring of power supply line and terminal block for external power supply.

- Applicable electric wire size is 0.14 to 1.5 mm² (AWG 16 to 26).
- Wire sheath stripped length is 4 to 6 mm.
- Too long stripped length might expose conductor and cause insulation failure, and too short stripped length might get the sheath caught or make the conductor unclamped or clamped improperly resulting in contact failure or disconnection of electric wire.
- The flat blade watch driver shall have 2.5 mm x 0.4 mm blade end width and hold the clamp opened.
- Tightening torque for terminal block: 0.22 N•m at minimum.

Maximum load current

Internal power supply type (EX510-DYN3, DYP3)

- The following three requirements shall be satisfied: (1) 0.5 A or less per point.
(2) 1 A or less per unit.
(3) Total current from OUT0 to 7 and from OUT8 to 15 is 1 A respectively.

Auxiliary power supply type (EX510-DYN4, DYP4)

- The following three requirements shall be satisfied: (1) 0.5 A or less per point.
(2) 3 A or less per unit.
(3) Total current from OUT0 to 7 and from OUT8 to 15 is 1.5 A respectively.

For the load to the light, place an in-rush current restriction resistor to prevent potential fusing due to in-rush current.

Specification

■ Specifications

Model No.	EX510-DYN3	EX510-DYP3	EX510-DYN4	EX510-DYP4
Output type	NPN	PNP	NPN	PNP
Rated load voltage	24 VDC *			
Power supply type	Internal power supply (from GW unit)		External power supply (from power supply connector)	
Power supply connector acceptable electric wire	-		0.14 to 1.5 mm ² (AWG16 to 26)	
Output point	16			
Output connector type	Cage clamp type			
Acceptable electric wire	0.08 to 1.5 mm ² (AWG16 to 28)			
Max. load current	Meet the three following conditions: (1) 1 point: 0.5 A or less (2) 1 unit: 1 A or less (3) Total current of OUT0 to 7: 1 A or less Total current of OUT8 to 15: 1 A or less		Meet the three following conditions: (1) 1 point: 0.5 A or less (2) 1 unit: 3 A or less (3) Total current of OUT0 to 7: 1.5 A or less Total current of OUT8 to 15: 1.5 A or less	
Enclosure	Short circuit installed			
Current consumption	50 mA or less (Internal unit)			
Weight	130 g (Include accessories)			

*: When conformity to UL is required, the product should be used with a UL1310 Class 2 power supply.

● Applicable manifold valve series

The Output unit can drive the 2-port valve of VX, VCW, VDW series, etc.

Refer to the catalogs and Operation Manual of each valve series for detail of the solenoid valve and manifold, etc.

■ Dimensions

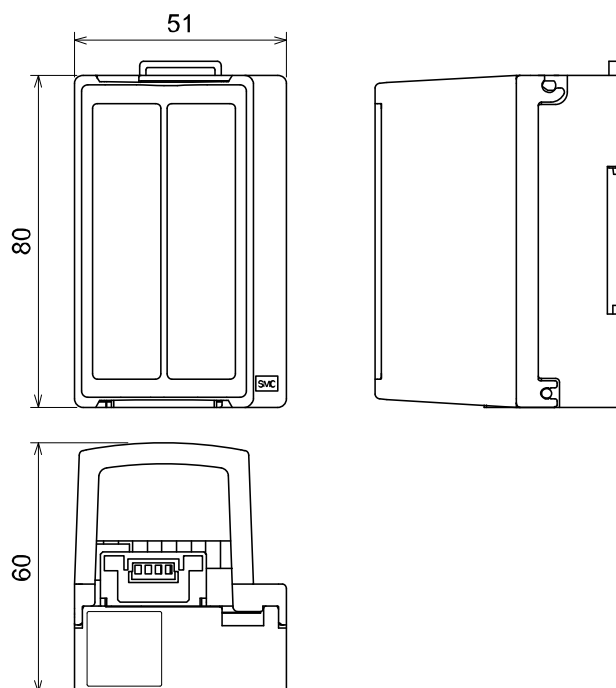

Input unit

Summary of Product Parts

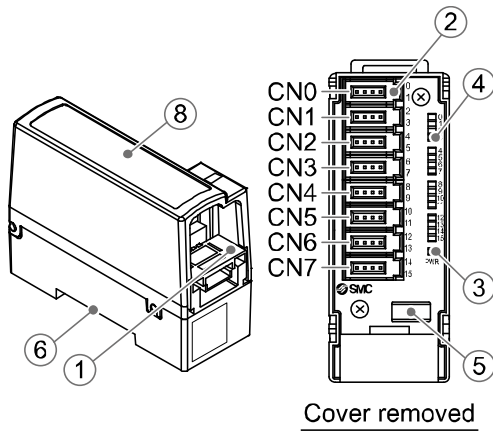

EX510-DX#1

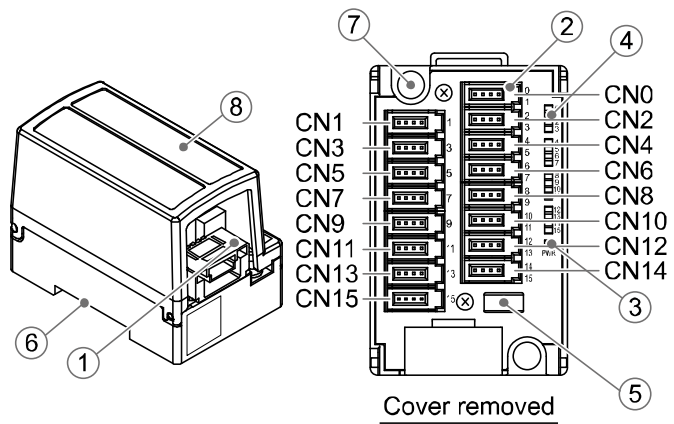

EX510-DX#2

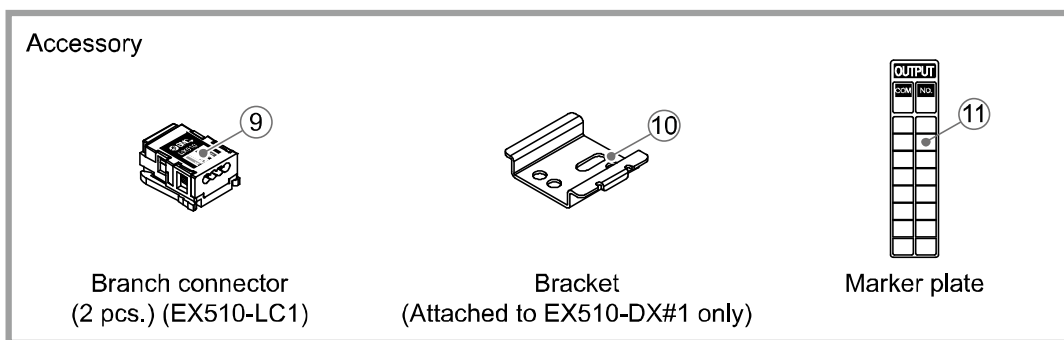

No.	Element	Description
1	Branch connector on the Input unit side	Used to crimp branch connector (⑨) into branch cable (EX510-FC##) and connected them to GW unit.
2	e-con socket	Used to connects sensor.
3	Power supply LED	Lights up: Power ON (normal) Goes off: Power OFF
4	Display LED	Lights up: Sensor signal input ON Goes off: Sensor signal input OFF
5	Fuse	Fuse is replaceable.
6	Mounting slot	Used for mounting the unit on DIN rail and with attached bracket (⑩) (thread mounting).
7	Mounting hole	Used to mount the unit with two M4 screws. (EX510-DX# only)
8	Cover	Used to protect sensor cable and provided with marker plate (⑪) on the top.

Mounting and Installation

■ Installation

● Mounted by screw

● EX510-DX#1

<Mounting example 1>

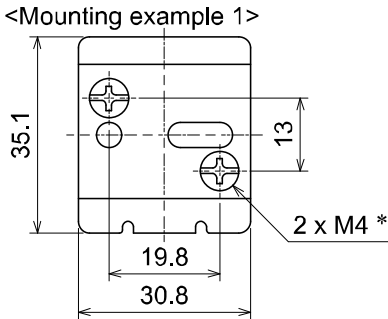

<Mounting example 2>

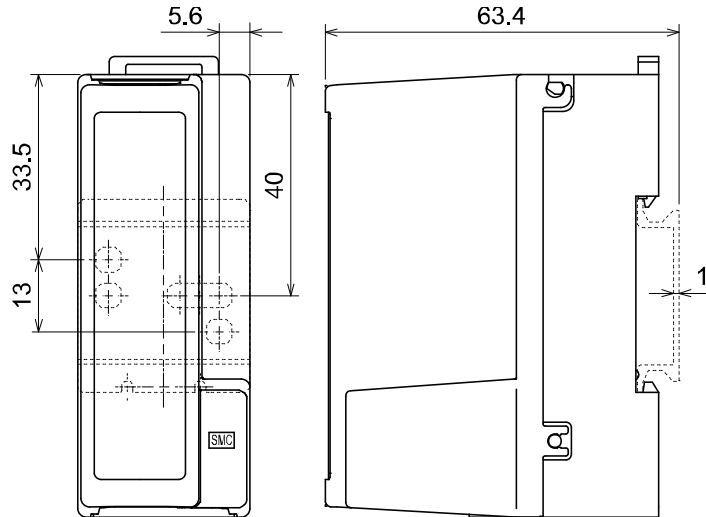
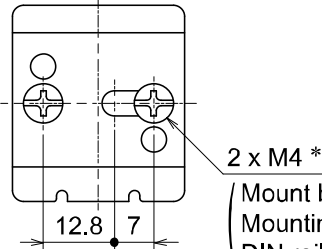

(Mount bracket with 2 pieces of M4 screw.
Mounting and removal method of bracket are the same as "Mounted on DIN rail" in the next item.)

● EX510-DX#2

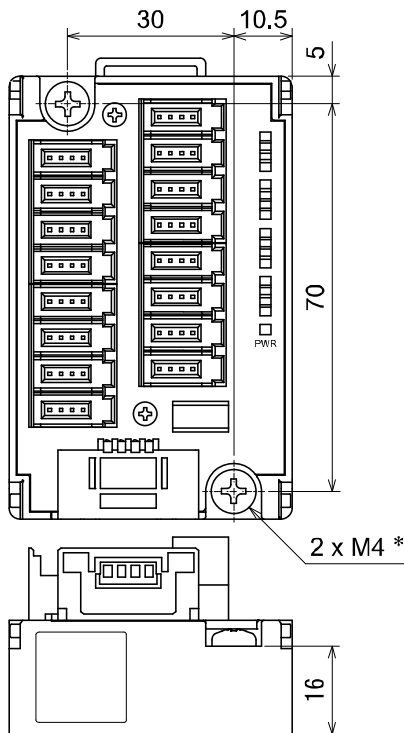

Cover removed (tolerance ± 0.2 mm)

*: Tightening torque: 0.8 N·m

•Mounted on DIN rail (Common to EX510-DX# and 2)

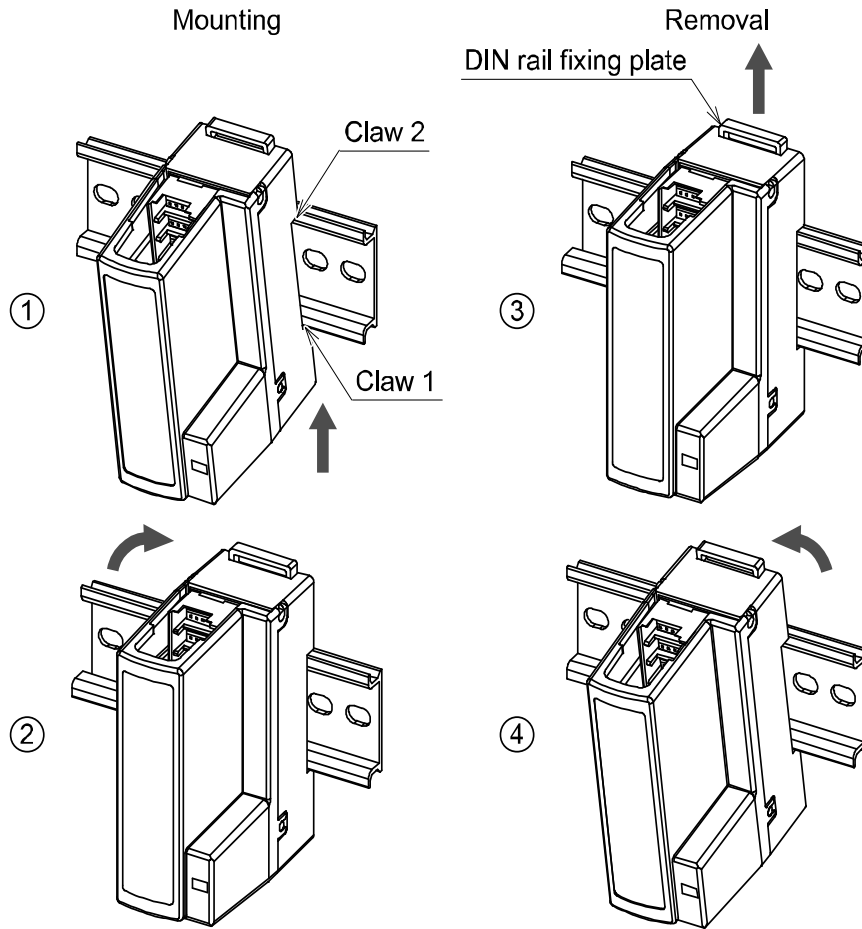

Put claw 1 at the body under DIN rail or bracket and push it upward. Push down claw 2 to the opposite rail until the claw clicks to be set stably. (Mounting procedure ① and ②)

For removing, push up DIN rail fixing plate at the body with a flat screwdriver, and remove it by tilting Claw 2 side forward. (Removal procedure ③ and ④)

■Wiring

●Internal circuit and wiring

●EX510-DXB1: Input unit for 2-wire type (1 connector 2-input type)

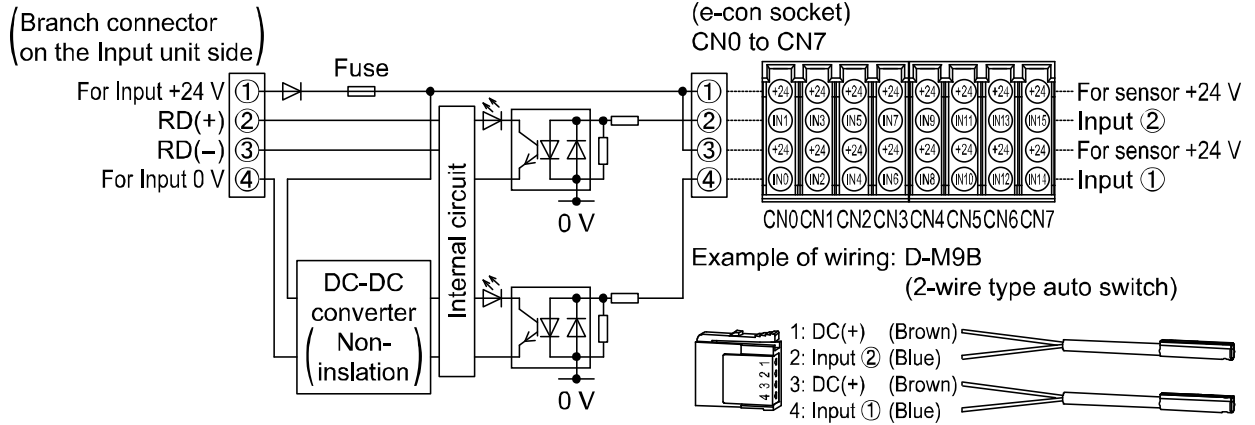

●EX510-DXN1: Input unit for NPN (1 connector 2-input type)

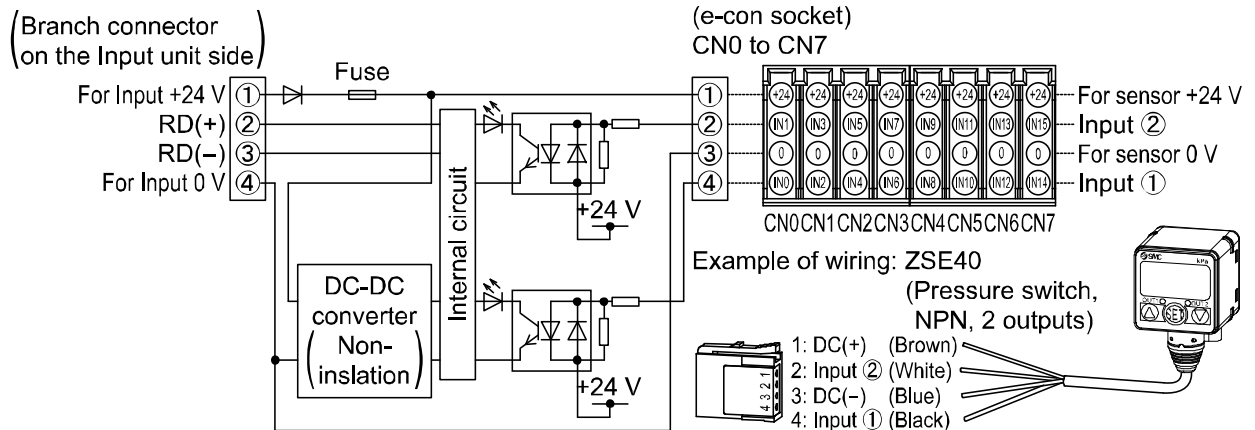

●EX510-DXP1: Input unit for PNP (1 connector 2-input type)

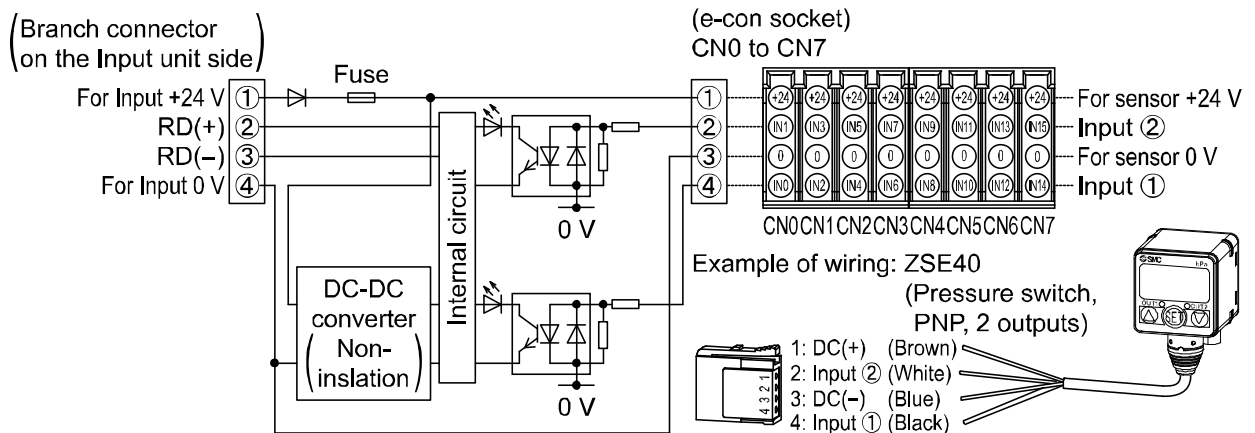

•EX510-DXN2: Input unit for NPN (1 connector 1 input type)

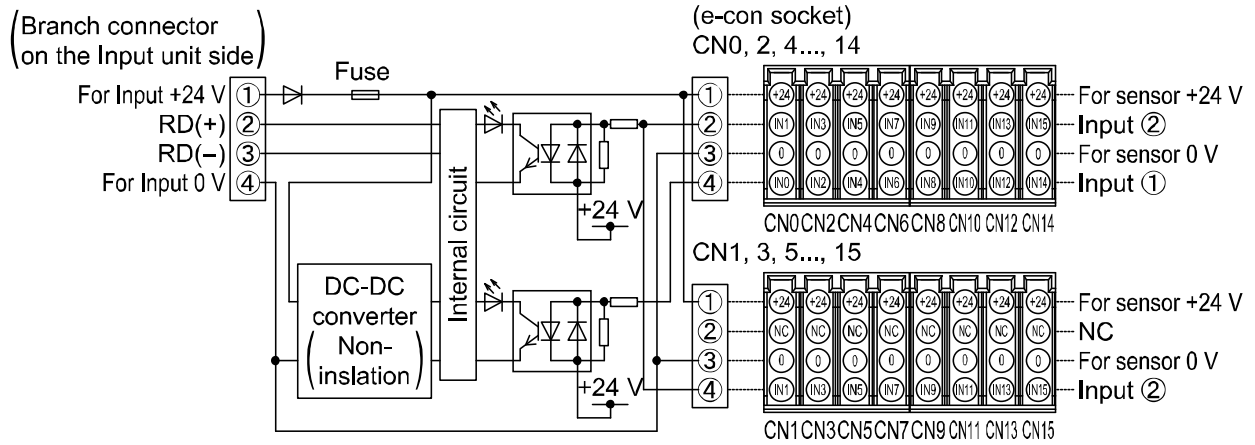

Example of wiring: D-M9N (3-wire type auto switch NPN output)

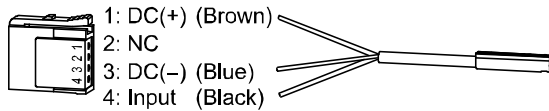

•EX510-DXP2: Input unit for PNP (1 connector 1 input type)

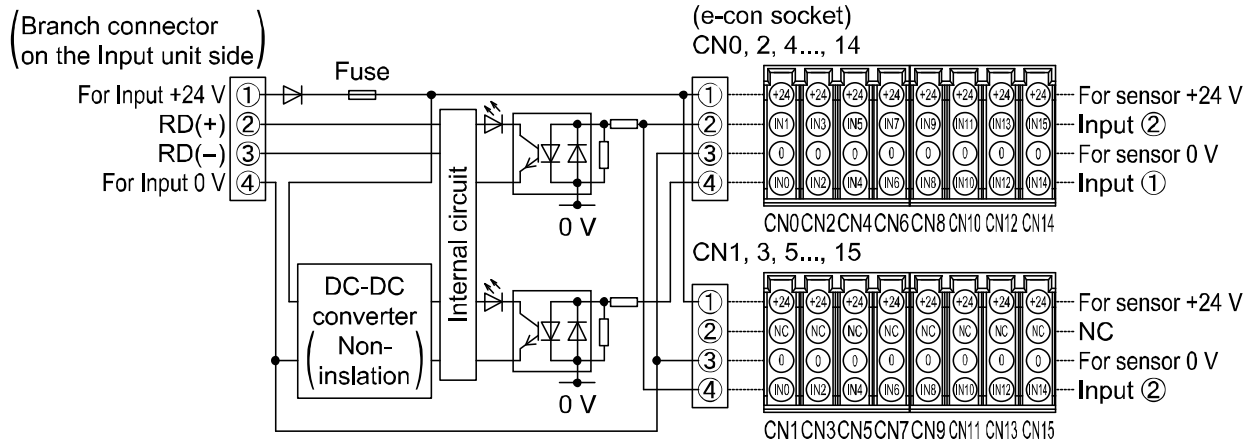

Example of wiring: D-M9P (3-wire type auto switch PNP output)

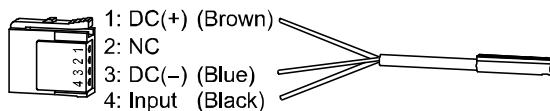

- Wiring of branch cables and e-con
 - Insert the branch connector at cable side into mating connector at Input unit side.
 - Connect e-con after removal of cover.

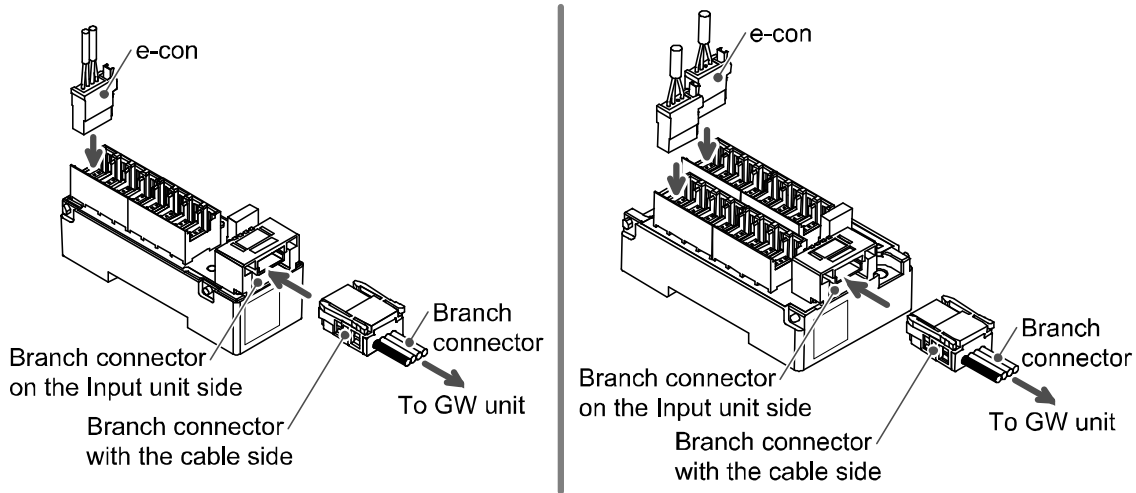

*: For crimping of a branch connector, refer to page 18.

- Sensor connection
 - Utilize e-con to connect the sensor to the Input unit.
 - Strip the sensor wire as shown in the right figure.
(Refer to the table below for correspondence between connector and electrical wire gauge.)

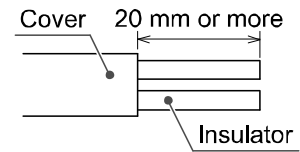

Applicable wire

SMC product No. (1pc.)	Colour of cover	Diameter (φ)	Nominal sectional area (mm ²) *1	AMP product No.
ZS-28-CA-1	Orange	0.6 to 0.9	0.1 to 0.5 (AWG26 to 20 *2)	3-1473562-4
ZS-28-CA-2	Red	0.9 to 1.0		1-1473562-4
ZS-28-CA-3	Yellow	1.0 to 1.15		1473562-4
ZS-28-CA-4	Blue	1.15 to 1.35		2-1473562-4
ZS-28-CA-5	Green	1.35 to 1.60		4-1473562-4

SMC product No. (1pc.)	Colour of cover	Diameter (φ)	Nominal sectional area (mm ²) *1	3M product No.
ZS-28-C	Red	0.8 to 1.0	0.14 to 0.2 (AWG26 to 24 *2)	37104-3101-000FL
ZS-28-C-1	Yellow	1.0 to 1.2		37104-3122-000FL
ZS-28-C-2	Orange	1.2 to 1.6		37104-3163-000FL
ZS-28-C-3	Green	1.0 to 1.2	0.3 to 0.5 (AWG22 to 20 *2)	37104-2124-000FL
ZS-28-C-4	Blue	1.2 to 1.6		37104-2165-000FL
ZS-28-C-5	Gray	1.6 to 2.0		37104-2206-000FL

SMC product No. (1pc.)	Colour of cover	Diameter (φ)	Nominal sectional area (mm ²) *1	OMRON product No.
-	Transparent	1.5 or less	0.08 to 0.5 (AWG28 to 20 *2)	XN2A-1470

*1: Nominal sectional area is the value provided by the manufacturer.

*2: AWG size is a reference.

- Insert the cable to the end with checking correspondence between color of cable and number stamped on e-con. (Refer to page 44 "Internal circuit and wiring")

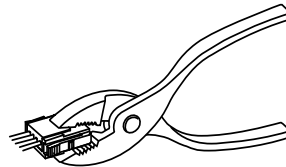
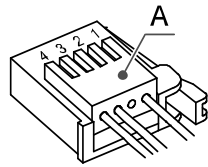

- It checks that the above-mentioned preparation work has been performed correctly, and "A" part shown in the left figure is pushed by hand and makes temporary connection.
- "A" part's center is straightly pushed in by tools, such as pliers.
- e-con is cannot be reused once crimped for connection. For the connection failure such as incorrect order of wire and incomplete insertion, please use the new e-con for sensor.

Specification

Specifications

Item	Specification		
Model No.	EX510-DXN#	EX510-DXP#	EX510-DXB1
Applicable sensor	NPN output	PNP output	2 wire type
Number of input points	16 points (Refer to diagram below for details.)		
Supply voltage for sensor	24 VDC *		
Max. supply current for sensor	0.2 A/1 point, 0.9 A/1 unit		
Current consumption	100 mA or less (inside of Input unit)		
Input resistance	5.6 kΩ		
Rated input current	4 mA or less		
ON voltage/ON current	17 V or more/2.5 mA or more (Between input terminal and +24 V for sensor)	17 V or more/2.5 mA or more (Between input terminal and 0 V for sensor)	
OFF voltage/OFF current	7 V or less/1 mA or less (Between input terminal and +24 V for sensor)	7 V or less/1 mA or less (Between input terminal and 0 V for sensor)	
LED display	Green LED (lights up during ON time)		
Weight	EX510-DX#1: 90 g, EX510-DX#2: 110 g (including accessories)		

*: When conformity to UL is required, the product should be used with a UL1310 Class 2 power supply.

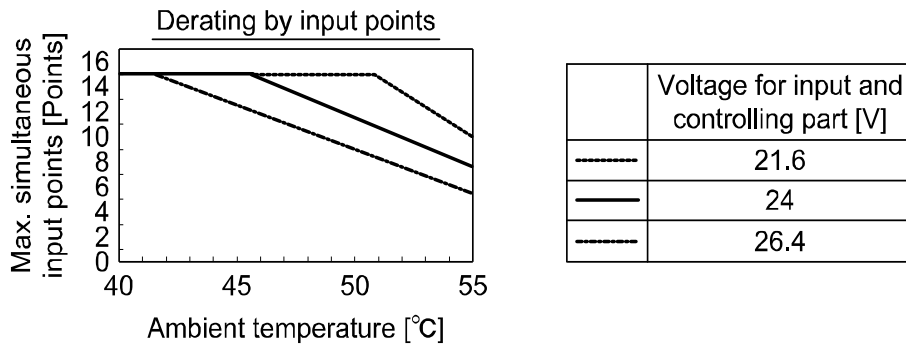

Dimensions

•EX510-DX#1

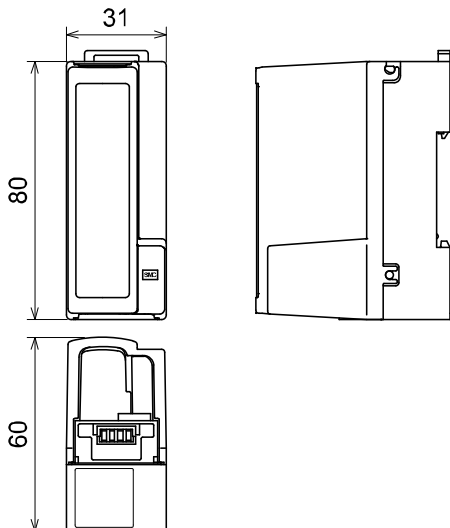

•EX510-DX#2

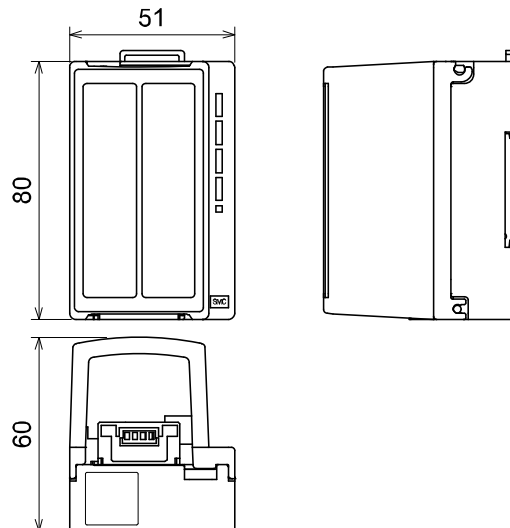

Maintenance

•Mounting and wiring conditions

Check items	Condition	Solution
Confirm the connectors of each unit (communication, power supply, input and output) is firmly connected.	No looseness	Give an additional tightening.
Confirm the terminating resistor is connected to both ends of network. (If this system is located at termination of network.)		
Confirm there is no breakage of connecting cable.	No defect on appearance	Replace with a new one if there is a defect found on appearance.

•Service parts

Check items	Condition	Solution
DeviceNet® compatible cable for moving parts (if used)	No defect on appearance and conductor resistance	Replace with a new one if there is a defect found on appearance and conductor resistance.
Display and operation	No defect on operating conditions and display	Replace with new unit if there is unintentional operation and defect found on display.

•Power supply

Check items	Condition	Solution
Measure the voltage at both ends of input and GW controlling part power supply and confirm the voltage is within specifications.	24 VDC \pm 10%	Investigate the cause of fluctuation of the voltage and take measure.
Measure the voltage at both ends of output power supply and confirm the voltage is within specifications.	24 VDC +10%/-5%	Investigate the cause of fluctuation of the voltage and take measure.

How to reset the product for power cut or forcible de-energizing

Supply power to the product.

The output status just before the power failure is not maintained when power supply is recovered.

Start operation after confirming safety of the entire equipment.

Troubleshooting

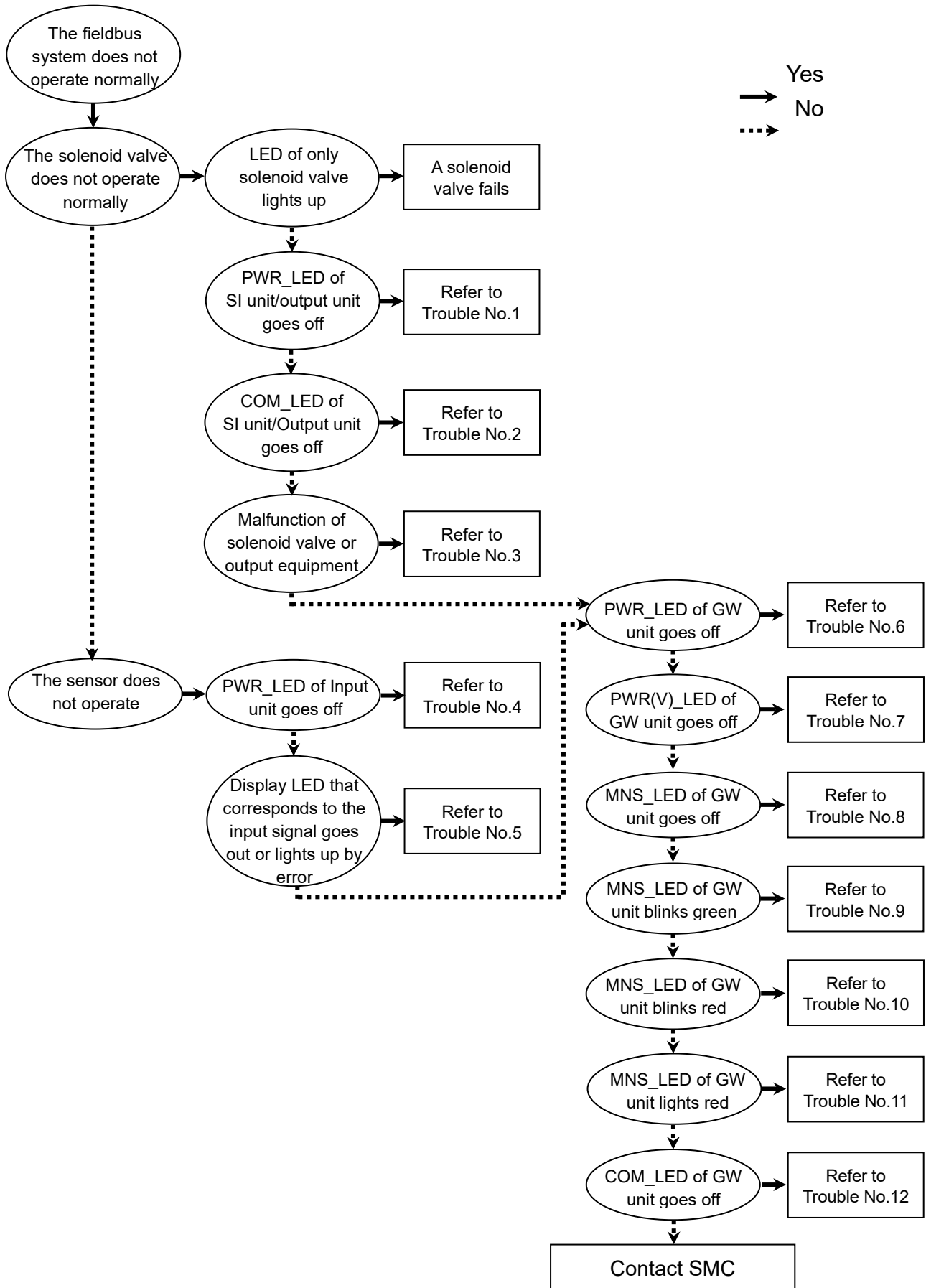

Trouble No.1

Trouble	Possible cause	Investigation method of cause	Solution
PWR LED of SI unit/Output unit goes off	Incorrect wiring of branch cable	Check that the cable of the branch cable is not broken or mis-connected or loosen at the connection.	Check the branch cable. (Replace the cable if it is broken.)
	Incorrect wiring of power source for output	Check that the power cable for output is correctly wired to the power connector of GW unit or Output unit.	Review the wiring.
	Failure of the power supply for the power for output	Check the power status for output.	Supply 24 VDC+10%/-5% to power source for output of GW unit or Output unit.

Trouble No.2

Trouble	Possible cause	Investigation method of cause	Solution
COM LED of SI unit/Output unit goes off	Incorrect wiring of branch cable	Check that the cable of the branch cable is not broken or mis-connected or loosen at the connection.	Check the branch cable. (Replace the cable if it is broken.)
	Failure of the branch cable	Check that the power supply line is not in the same route as the power line and/or the high voltage line.	Separate the power supply cable from the power line and/or high voltage line. Supply power to GW unit or the Output unit after separation is confirmed to be completed.
		Check the wire length of the branch cable and if the exclusive cable is used.	Review the wiring of the branch cable.

Trouble No.3

Trouble	Possible cause	Investigation method of cause	Solution
Malfunction of solenoid valve or Output unit	Incorrect wiring or connection between SI unit/Output unit and solenoid valve/output equipment	Check that the connections of the connectors between SI unit/Output unit and solenoid valve/output equipment are not loosened.	Check the connection between SI unit/Output unit and solenoid valve/output equipment.
		Check that the cables between SI unit/Output unit and solenoid valve/output equipment is not broken or mis-connected.	Check the connection between SI unit/Output unit and solenoid valve/output equipment. (Replace the cable if it is broken.)
	Abnormal power voltage	Check that the supply power voltage from SI unit/Output unit is within the power supply voltage range, and that the branch cable length and the specified current of the unit are within the specified range.	Supply 24 VDC+10%/-5% to the solenoid valve/power supply for output.
	Malfunction with the solenoid valve or output equipment	Check the troubleshooting of solenoid valve/output equipment.	Check the troubleshooting of solenoid valve/output equipment.
	Malfunction with the solenoid valve or output equipment	Replace the SI unit/Output unit with other one to check if it operates normally.	Replace the SI unit/Output unit.

Trouble No.4

Trouble	Possible cause	Investigation method of cause	Solution
PWR LED of the Input unit goes off	Incorrect wiring of the branch cable	Check that the cable of the branch cable is not broken or mis-connected or loosen at the connection.	Check the connection of the branch cable. (Replace the cable if it is broken.)
	Incorrect wiring of power supply to the controller for input and GW	Check that the wiring of the power supply for controller for input and GW to the power supply connector of the GW unit is correctly done.	Review the wiring of the power cable of GW unit.
	Failure of the power supply to the controller for input and GW	Check the power supply status to the controller for input and GW.	Supply 24 VDC±10% to the input of GW unit and power supply to the controller for GW.
	Fuse of the Input unit blows	Check that fuse of the Input unit is not blown.	Eliminate the cause of short-circuit and replace the fuse.
	Malfunction with the Input unit	Replace the Input unit and check if it operates normally.	Replace the Input unit.

Trouble No.5

Trouble	Possible cause	Investigation method of cause	Solution
Display LED corresponding to input signal goes off or lights up by error	Inconsistent polarity in sensors	Check that the Input unit specifications (NPN, PNP) and the sensor specifications are consistent.	Make a suitable combination of Input unit and sensor.
	Incorrect connection of the sensor	Check that the sensor cable is not broken and the connection between the sensor cable and the connector is not loosened.	Review the connection of the sensor cable. (Replace the cable if it is broken.)
	Sensor failure	Check the troubleshooting of the sensor.	Check the troubleshooting of the sensor.

Trouble No.6

Trouble	Possible cause	Investigation method of cause	Solution
PWR LED of GW unit goes off	Incorrect wiring of the communication power supply for DeviceNet®	Check that the cable of communication power supply for DeviceNet® is not broken and the connection between the power supply cable and the connector is not loosened.	Review the connection of the power supply cable. (Replace the cable if it is broken.)
		Check that the wiring of the power supply cable is correctly done.	Review the wiring of the power supply cable.
	Failure of the power supply of the communication power supply for DeviceNet®	Check the supply voltage to the communication power supply for DeviceNet®.	Supply 11 V to 25 VDC to the communication power supply for DeviceNet®.

Trouble No.7

Trouble	Possible cause	Investigation method of cause	Solution
PWR(V) LED of GW unit goes off	Incorrect wiring of the power supply for output	Check that the cable of the power supply for output is not broken and the connection between the power supply cable and connector is not loosened.	Review the connection of the power supply cable. (Replace the cable if it is broken.)
		Check that the wiring of the power supply cable is correctly done.	Check the wiring of the power supply cable.
	Failure of the power supply for output	Check the supply voltage to the power supply for output.	Supply 24 VDC+10%/-5%to the power supply for output.
	Incorrect wiring of the power supply for the input and controlling GW	Check that the cable of the power supply for input and controlling GW is not broken and the connection between the power supply cable and connector is not loosened.	Check the connection of the power supply cable. (Replace the cable if it is broken.)
		Check that the wiring of the power supply cable is correctly done.	Review the wiring of the power supply cable.
Failure with the power supply of input and controlling GW	Check the supply voltage to the power supply for input and controlling GW.	Supply 24 VDC±10% to the power supply for input and controlling GW.	

Trouble No.8

Trouble	Possible cause	Investigation method of cause	Solution
MNS LED of GW unit goes off	Communication setting error	Check that the communication speed of the PLC and GW unit is consistent.	Review the setting of the communication speed.
	Communication error	Check the wiring length of the communication line against the communication speed, the existence of the terminal resistance at the both end of the main line, and that the exclusive cable for DeviceNet® is used.	Review the wiring.

Trouble No.9

Trouble	Possible cause	Investigation method of cause	Solution
Green blinking of MNS LED of GW unit	The connection is standing by	Check that the PLC master makes normal operation.	Review the PLC setting.
		Check that the GW unit is correctly registered to the scan list if a scan list is used for the network.	Check the registration of the scan list.

Trouble No.10

Trouble	Possible cause	Investigation method of cause	Solution
Red blinking of MNS LED of GW unit	Communication connection timeout	Check if the DeviceNet® cable length is within specification (trunk line and drop line).	Configure DeviceNet® cable as specified by DeviceNet® specification.
		Check the DeviceNet® communication cable is not broken and there is no loose connection. Check that no repetitive bending stress or pulling force is being applied to the cable.	Connect the DeviceNet® communication cable correctly.
		Check the terminating resistor (121 Ω) is installed at both ends of the trunk line.	Install the terminating resistor (121 Ω) properly.
		Check that the FG terminal is grounded.	Ground the FG terminal to improve the noise resistance of the fieldbus system.
		Check that the power supply line is not in the same route as the power line and/or high voltage line.	Separate the power supply line from the power line and the high voltage line.
		Confirm that power is supplied to the master station.	Supply power to the master station correctly.

Trouble No.11

Trouble	Possible cause	Investigation method of cause	Solution
Red blinking of MNS LED of GW unit	Duplicated MAC ID	Check that the MAC ID is not duplicated.	Review the MAC ID setting.
	Communication setting error	Check that the communication speed of PLC and GW unit is inconsistent.	Review the communication speed setting.
	Abnormal status of GW unit	Check that FG terminal is grounded.	Ground the FG terminal to improve the noise resistance of the fieldbus system.
		Check that the power supply line is not in the same route as the power line and/or high voltage line.	Separate the power supply line from the power line and the high voltage line.
	GW unit failure	Replace the GW unit and check if it makes normal operation.	Replace the GW unit.

Trouble No.12

Trouble	Possible cause	Investigation method of cause	Solution
COM LED of GW unit goes off	Incorrect wiring of the branch cable	Check that the cable of the branch cable is not broken or mis-connected, and that the connection is not loosened.	Review the connection of the branch cable. (Replace the cable if it is broken.)
	Incomplete connection of the Input unit	Check that the Input unit is connected after the input port.	Check that the Input unit is connected after the input port.
	Incorrect wiring of the power supply for input and control for GW	Check that the wiring of the power supply of input and GW unit control to the power supply connector of the GW unit is correctly made.	Review the wiring of the power supply cable of GW unit.
	Power supply failure of the power for input and control for GW	Check the power supply state of the control for input and GW.	Supply 24VDC±10% to the power supply to control for GW and input of GW.
	Fuse of the Input unit blown	Check that the fuse of the Input unit is not blown.	Replace the fuse.

Option

•Branch cable

It is a 4-core flat cable used for connection between each unit.

EX510-FC 1 0

Cable length [L]

01	1 m
02	2 m
05	5 m
10	10 m
20	20 m
60*	60 m

*: Cable length of 20 m is available.
Cut the cable in 20 m or less.

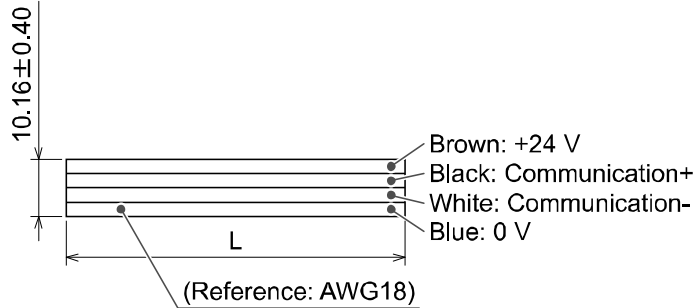

•Branch connector (Every 1 pc.)

It is a connector used to connect the branch cable to each unit.

SI unit and Input unit are attached with the branch connector for 2 pcs. each.

EX510-LC1



(When pressure welding)

Electric specification	
Rated voltage	24 VDC
Rated current	Max. 5.0 A
Contact resistance	20 mΩ or less
Withstand voltage	1000 VAC per 1 minute (Leak current 1 mA or less)

•Cable assembly for output entry

It is a cable assembly to take the remaining output of the SI unit out of it.

EX510-V S 1 0 S

Output point

S	1 point
W	2 points

Valve connector

Nil	Without valve connector
S	For SY/SYJ
Q	For VQ/VQZ *

*: The common(+) type of VQ series is only available.

Cable length [L]

10	1.0 m
30	3.0 m

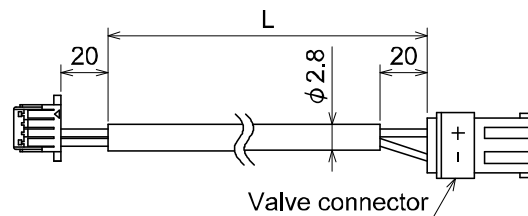

●**e-con**

It is a connector used for connecting a sensor to the Input unit (EX510-DX##).

Refer to "Sensor connection" on page 46 for the connector part number and the applicable electric wire size.

ZS-28-C □ - □

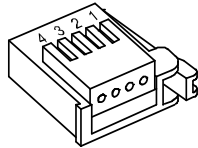

●**Fuse for replacement**

It is a fuse for replacement used for Input unit(EX510-DX##) and Output(EX510-DY##) unit.

EX9-FU 1 0

Object model No.

10	1 A
50	5 A

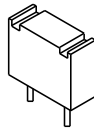

Electric specification		
Model no.	EX9-FU10	EX9-FU50
Applicable model	EX510-DX## EX510-DY#3	EX510-DY#4
Rated current	1 A	5 A
Rated insulation capacity	48 VAC/DC 50 A	
Fuse resistance value	0.145 Ω	18 mΩ

Revision history

A: Correct words.
B: Add the explanation of the setting method for each function.
Correct words.
C: Add the contents.
D: Revision.
E: Modified errors in text.
F: Limited warranty and Disclaimer are added.
G: Contents revised in several places.
H: Contents revised in several places.
I: Contents revised in several places [May 2024]

SMC Corporation

Tel: + 81 3 5207 8249 Fax: +81 3 5298 5362

URL <https://www.smcworld.com>

Note: Specifications are subject to change without prior notice and any obligation on the part of the manufacturer.
© SMC Corporation All Rights Reserved

