



# Operation Manual

PRODUCT NAME

SI unit for CC-Link

MODEL / Series / Product Number

*EX180-SMJ3/5# Series*

**SMC Corporation**

# Contents

Safety Instructions	2
How to Order	7
Summary of Product Parts	8
Definition and terminology	8
Installation and Cabling	9
General Instructions on installation	9
Connecting cables	10
LED Display and Settings	12
Troubleshooting and Maintenance	16
Maintenance	20
Specifications	21
Table of specifications	21
Dimensions	22



# Safety Instructions

These safety instructions are intended to prevent hazardous situations and/or equipment damage. These instructions indicate the level of potential hazard with the labels of “**Caution**,” “**Warning**” or “**Danger**.” They are all important notes for safety and must be followed in addition to International Standards (ISO/IEC)<sup>\*1)</sup>, and other safety regulations.

\*1) ISO 4414: Pneumatic fluid power - General rules and safety requirements for systems and their components  
ISO 4413: Hydraulic fluid power - General rules and safety requirements for systems and their components  
IEC 60204-1: Safety of machinery - Electrical equipment of machines - Part 1: General requirements  
ISO 10218-1: Robots and robotic devices - Safety requirements for industrial robots - Part 1: Robots  
etc.



## Danger

**Danger** indicates a hazard with a high level of risk which, if not avoided, will result in death or serious injury.



## Warning

**Warning** indicates a hazard with a medium level of risk which, if not avoided, could result in death or serious injury.



## Caution

**Caution** indicates a hazard with a low level of risk which, if not avoided, could result in minor or moderate injury.



## Warning

### 1. The compatibility of the product is the responsibility of the person who designs the equipment or decides its specifications.

Since the product specified here is used under various operating conditions, its compatibility with specific equipment must be decided by the person who designs the equipment or decides its specifications based on necessary analysis and test results. The expected performance and safety assurance of the equipment will be the responsibility of the person who has determined its compatibility with the product. This person should also continuously review all specifications of the product referring to its latest catalog information, with a view to giving due consideration to any possibility of equipment failure when configuring the equipment.

### 2. Only personnel with appropriate training should operate machinery and equipment.

The product specified here may become unsafe if handled incorrectly. The assembly, operation and maintenance of machines or equipment including our products must be performed by an operator who is appropriately trained and experienced.

### 3. Do not service or attempt to remove product and machinery/equipment until safety is confirmed.

1. The inspection and maintenance of machinery/equipment should only be performed after measures to prevent falling or runaway of the driven objects have been confirmed.
2. When the product is to be removed, confirm that the safety measures as mentioned above are implemented and the power from any appropriate source is cut, and read and understand the specific product precautions of all relevant products carefully.
3. Before machinery/equipment is restarted, take measures to prevent unexpected operation and malfunction.

### 4. Our products cannot be used beyond their specifications. Our products are not developed, designed, and manufactured to be used under the following conditions or environments. Use under such conditions or environments is not covered.

1. Conditions and environments outside of the given specifications, or use outdoors or in a place exposed to direct sunlight.
2. Use for nuclear power, railways, aviation, space equipment, ships, vehicles, military application, equipment affecting human life, body, and property, fuel equipment, entertainment equipment, emergency shut-off circuits, press clutches, brake circuits, safety equipment, etc., and use for applications that do not conform to standard specifications such as catalogs and operation manuals.
3. Use for interlock circuits, except for use with double interlock such as installing a mechanical protection function in case of failure. Please periodically inspect the product to confirm that the product is operating properly.



# Safety Instructions

## Caution

**We develop, design, and manufacture our products to be used for automatic control equipment, and provide them for peaceful use in manufacturing industries.**

**Use in non-manufacturing industries is not covered.**

Products we manufacture and sell cannot be used for the purpose of transactions or certification specified in the Measurement Act.

The new Measurement Act prohibits use of any unit other than SI units in Japan.

## Limited warranty and Disclaimer/Compliance Requirements

The product used is subject to the following “Limited warranty and Disclaimer” and “Compliance Requirements”.

Read and accept them before using the product.

### Limited warranty and Disclaimer

1. The warranty period of the product is 1 year in service or 1.5 years after the product is delivered, whichever is first.\*2)  
Also, the product may have specified durability, running distance or replacement parts. Please consult your nearest sales branch.
2. For any failure or damage reported within the warranty period which is clearly our responsibility, a replacement product or necessary parts will be provided.  
This limited warranty applies only to our product independently, and not to any other damage incurred due to the failure of the product.
3. Prior to using SMC products, please read and understand the warranty terms and disclaimers noted in the specified catalog for the particular products.

**\*2) Vacuum pads are excluded from this 1 year warranty.**

A vacuum pad is a consumable part, so it is warranted for a year after it is delivered.

Also, even within the warranty period, the wear of a product due to the use of the vacuum pad or failure due to the deterioration of rubber material are not covered by the limited warranty

### Compliance Requirements

1. The use of SMC products with production equipment for the manufacture of weapons of mass destruction (WMD) or any other weapon is strictly prohibited.
2. The exports of SMC products or technology from one country to another are governed by the relevant security laws and regulations of the countries involved in the transaction. Prior to the shipment of a SMC product to another country, assure that all local rules governing that export are known and followed.

## Operator

- ◆ This operation manual is intended for those who have knowledge of machinery using pneumatic equipment, and have sufficient knowledge of assembly, operation and maintenance of such equipment. Only those persons are allowed to perform assembly, operation and maintenance.
- ◆ Read and understand this operation manual carefully before assembling, operating or providing maintenance to the product.

### ■ Safety Instructions

#### **Warning**

- Do not disassemble, modify (including changing the printed circuit board) or repair.  
Do not use the components other than the specified components.  
An injury or failure can result.
- Do not operate the product outside of the specifications.  
Do not use for flammable or harmful fluids.  
Fire, malfunction, or damage to the product can result.  
Verify the specifications before use.
- Do not operate in an atmosphere containing flammable or explosive gases.  
Fire or an explosion can result.  
This product is not designed to be explosion proof.
- If using the product in an interlocking circuit:
  - Provide a double interlocking system, for example a mechanical system.
  - Check the product regularly for proper operation.Otherwise malfunction can result, causing an accident.
- The following instructions must be followed during maintenance:
  - Turn off the power supply.
  - Stop the air supply, exhaust the residual pressure and verify that the air is released before performing maintenance.Otherwise an injury can result.

#### **Caution**

- After maintenance is complete, perform appropriate functional inspections.  
Stop operation if the equipment does not function properly.  
Safety cannot be assured in the case of unexpected malfunction.
- Provide grounding to assure the noise resistance of the Fieldbus system.  
Individual grounding should be provided close to the product with a short cable.

## ■NOTE

○Follow the instructions given below when designing, selecting and handling the product.

- The instructions on design and selection (installation, wiring, environment, adjustment, operation, maintenance, etc.) described below must also be followed.

### \*Product specifications

- When conformity to UL is necessary the SI unit must be used with a UL1310 Class2 power supply.
- The SI unit is a UL approved product only if they have a  mark on the body.
- Use the specified voltage.  
Otherwise failure or malfunction can result.
- Reserve a space for maintenance.  
Allow sufficient space for maintenance when designing the system.
- Do not remove any nameplates or labels.  
This can lead to incorrect maintenance, or misreading of the operation manual, which could cause damage or malfunction to the product.  
It may also result in non-conformity to safety standards.

### ●Product handling

#### \*Installation

- Do not drop, hit or apply excessive shock to the fieldbus system.  
Otherwise damage to the product can result, causing malfunction.
- Tighten to the specified tightening torque.  
If the tightening torque is exceeded the mounting screws may be broken.
- Never mount a product in a location that will be used as a foothold.  
The product may be damaged if excessive force is applied by stepping or climbing onto it.

#### \*Wiring

- Avoid repeatedly bending or stretching the cables, or placing heavy load on them.  
Repetitive bending stress or tensile stress can cause breakage of the cable.
- Wire correctly.  
Incorrect wiring can break the product.
- Do not perform wiring while the power is on.  
Otherwise damage to the fieldbus system and/or I/O device can result, causing malfunction.
- Do not route wires and cables together with power or high voltage cables.  
Otherwise the fieldbus system and/or I/O device can malfunction due to interference of noise and surge voltage from power and high voltage cables to the signal line.  
Route the wires (piping) of the fieldbus system and/or I/O device separately from power or high voltage cables.
- Confirm proper insulation of wiring.  
Poor insulation (interference from another circuit, poor insulation between terminals, etc.) can lead to excess voltage or current being applied to the product, causing damage.
- Take appropriate measures against noise, such as using a noise filter, when the fieldbus system is incorporated into equipment.  
Otherwise noise can cause malfunction.

#### \*Environment

- Do not use the product in area that is exposed to corrosive gases, chemicals, sea water, water or steam.  
Otherwise failure or malfunction can result.
- Do not use in an area where surges are generated.  
If there is equipment which generates a large amount of surge (solenoid type lifter, high frequency induction furnace, motor, etc.) close to the fieldbus system, this may cause deterioration or breakage of the internal circuit of the fieldbus system. Avoid sources of surge generation and crossed lines.
- When a surge-generating load such as a relay or solenoid is driven directly, use an fieldbus system with a built-in surge absorbing element.  
Direct drive of a load generating surge voltage can damage the fieldbus system.
- The product is CE/UKCA marked, but not immune to lightning strikes. Take measures against lightning strikes in the system.
- Prevent foreign matter such as remnant of wires from entering the fieldbus system to avoid failure and malfunction.
- Mount the product in a place that is not exposed to vibration or impact.  
Otherwise failure or malfunction can result.
- Do not use the product in an environment that is exposed to temperature cycle.  
Heat cycles other than ordinary changes in temperature can adversely affect the inside of the product.
- Do not expose the product to direct sunlight.  
If using in a location directly exposed to sunlight, shade the product from the sunlight.  
Otherwise failure or malfunction can result.
- Keep within the specified ambient temperature range.  
Otherwise malfunction can result.
- Do not operate close to a heat source, or in a location exposed to radiant heat.  
Otherwise malfunction can result.

#### \*Adjustment and Operation

- Set the switches by using a sharp-pointed screwdriver etc.  
It may damage set switches.
- Perform settings suitable for the operating conditions.  
Incorrect setting can cause operation failure.  
For details of each setting, refer to page 13 of this manual.
- Please refer to the PLC manufacturer's manual etc. for details of programming and addresses.  
For the PLC protocol and programming refer to the relevant manufacturer's documentation.

#### \*Maintenance

- Turn off the power supply, stop the supplied air, exhaust the residual pressure and verify the release of air before performing maintenance.  
There is a risk of unexpected malfunction.
- Perform regular maintenance and inspections.  
There is a risk of unexpected malfunction.
- After maintenance is complete, perform appropriate functional inspections.  
Stop operation if the equipment does not function properly.  
Otherwise safety is not assured due to an unexpected malfunction or incorrect operation.
- Do not use solvents such as benzene, thinner etc. to clean the each unit.  
They could damage the surface of the body and erase the markings on the body.  
Use a soft cloth to remove stains.  
For heavy stains, use a cloth soaked with diluted neutral detergent and fully squeezed, then wipe up the stains again with a dry cloth.

## How to Order

- EX180 series SI unit

EX180-S MJ □

- Communication connector specifications

Nil	T branch type
A	Straight type

- Network, number of outputs, output type

MJ3	Applicable for CC-Link, 32 outputs, NPN (positive common)/sink
MJ5	Applicable for CC-Link, 32 outputs, PNP (negative common)/source

- Accessories: Communication connector

EX180-C MJ □

- Communication connector specifications

1	T branch type
2	Straight type

- Network

MJ	Applicable for CC-Link
----	------------------------

- Accessories: Power supply connector

EX180-CP1



## Summary of Product Parts

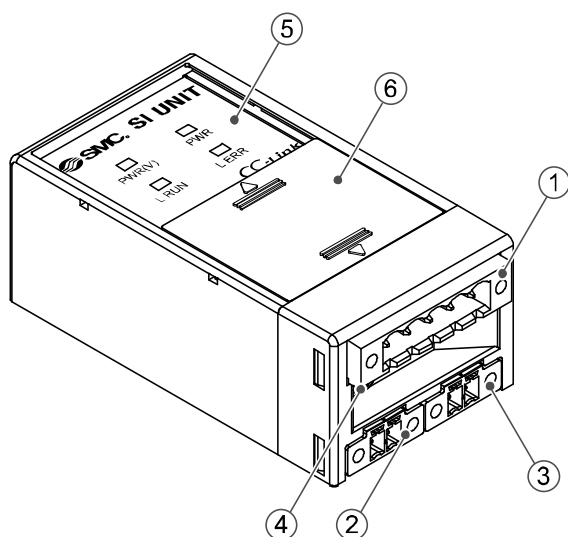

Communication connector for CC-Link (1 pc.)  
EX180-SMJ3/5                      EX180-SMJ3A/5A

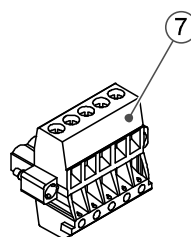

(EX180-CMJ1)

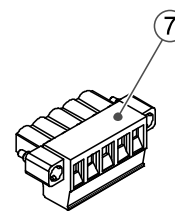

(EX180-CMJ2)

Power supply connector (2 pcs.)

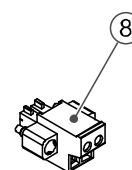

(EX180-CP1)

### Accessories

No.	Element	Description
1	Fieldbus interface connector (BUS)	The connector for CC-Link (⑦) that is used to connect to the CC-Link bus line.
2	Socket for the power supply (PWR(V))	The connector for the power supply (⑧) that is used to supply the power for the solenoid valves.
3	Socket for the power supply (PWR)	The connector for the power supply in accessories (⑧) that is used to supply the power for the SI unit.
4	FG terminal	Functional Earth.
5	Display	LED diagnostic display.
6	Switch setting part	Set the number of the host stations and the communication speed.

### ■ Definition and terminology

	Term	Explanation
N	Node number	0 is assigned to the master station of the CC-Link network. 1 to 64 are assigned to slave stations. It is necessary to assign node numbers to slave stations taking into consideration the number of occupied stations, so that node numbers are not duplicated.
	Number of stations	The total number of occupied slave stations connected to the CC-Link network
O	Occupied node number	Station number that one slave station uses on the network. It can be set from 1 to 4 stations depending on the amount of data.
R	Remote I/O	Station for which only bit data can be used. Occupies only one station. (Example: Digital unit, solenoid valve, sensor, etc.)
S	Slave station	Collective description of stations other than the master station.

## Installation and Cabling

### ■ General Instructions on installation

#### ○ Applicable valve series

The EX180 series SI unit can be mounted on the following valve manifolds.

#### ● Manifold

SJ2000, SJ3000, S0700 series

\*: Refer to the catalogues and operation manuals for details on the solenoid valves and manifolds.

#### ● How to mount the manifold

1. Mount the SI unit to the manifold so that the mounting guide of the SI unit case mates with the manifold groove.
2. Secure the SI unit using the two sliding locks.

①

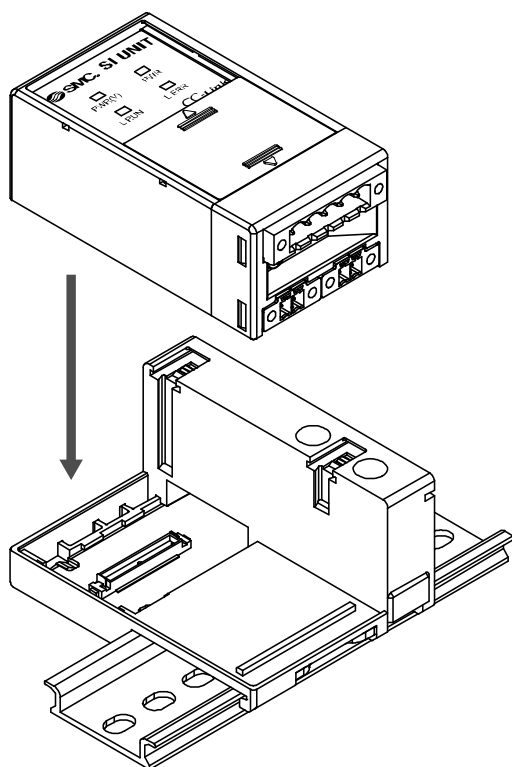

②

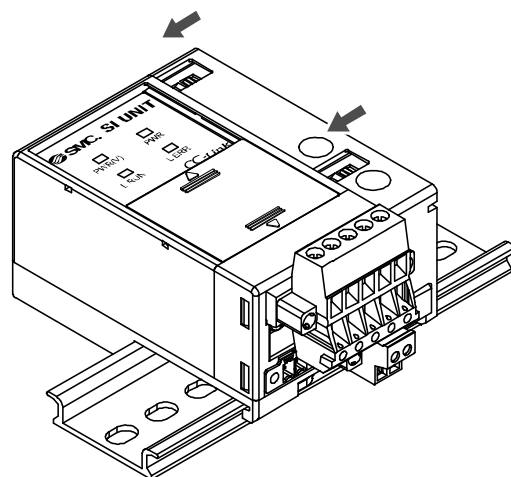

#### ● Caution

The EX180-SMJ1□ can not mount on the valve manifold for the EX180-SMJ3□/5□.

The EX180-SMJ3□/5□ also can not mount on the valve manifold for the EX180-SMJ1□.

## ■Connecting cables

### 1. Wiring for communication

Wiring of the CC-Link cable and communication connector is shown below.

(1)Connect the signal lines to the assigned pins. (Figure 1)

The CC-Link communication connector is suitable for use with wire sizes from AWG24 to 12 (0.2 mm<sup>2</sup> to 2.5 mm<sup>2</sup>).

The required tightening torque is 0.5 to 0.6 Nm.

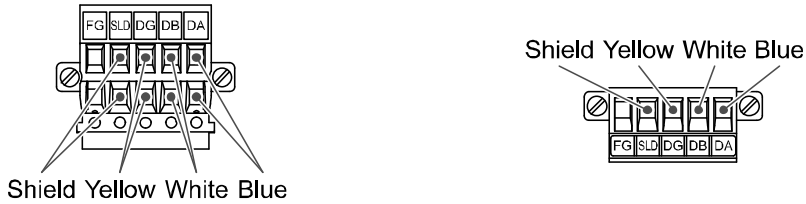

Figure 1

(2)Use the internal terminating resistor only when the SI unit is placed at the end of the CC-Link main line. An external terminating resistor should not be used when the internal resistor is used. The terminating resistor value will be outside the specified range. A network communication error may occur.

\*: Refer to page 13 for the switch settings.

(3)How to connect.

- Note

Connect the shield line for CC-Link cable to "SLD" of each unit.

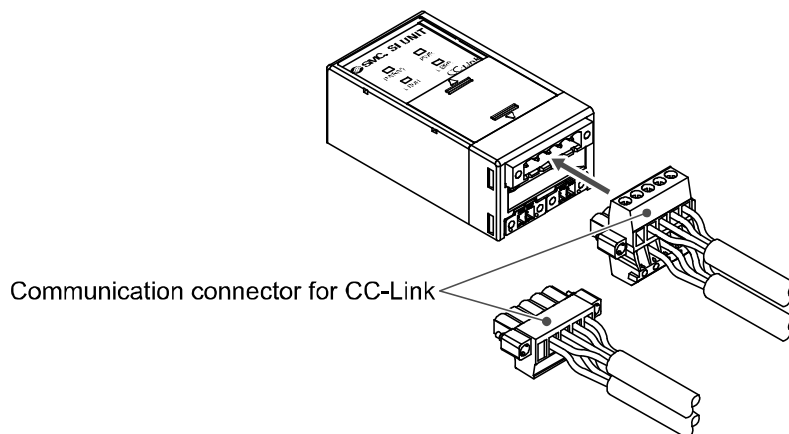

Figure 2

## 2. Wiring of the power supply

Connect the power supply to the power supply connector (2 pcs.).

The power supply connector is suitable for use with wire sizes from AWG28 to 16 (0.14 mm<sup>2</sup> to 1.5 mm<sup>2</sup>). The EX180 power supply structure consists of two systems. These systems can operate alone or with another power supply.

Wire to the assigned pins. (Figure 3, Figure 4)

The tightening torque is 0.22 to 0.25 Nm.

### ●Note

Ground the FG terminal with a ground resistance of 100 Ω or less.

Tighten the FG terminal (M3 round head combination screw) firmly with a tightening torque of 0.3 Nm.

Tighten the connector fixing screws (M2.5 slotted head screws) firmly with a tightening torque of 0.2 to 0.3 Nm.

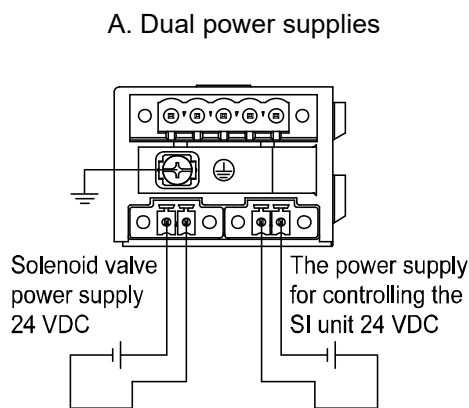

Figure 3

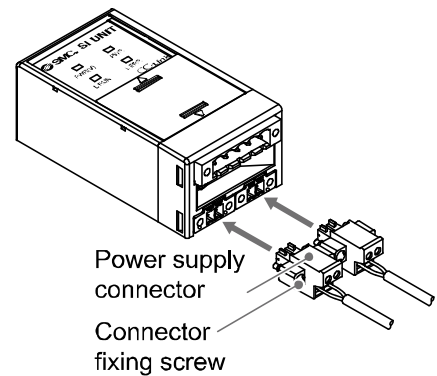
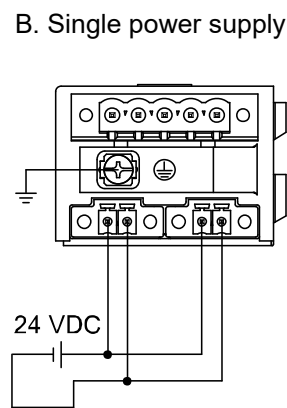
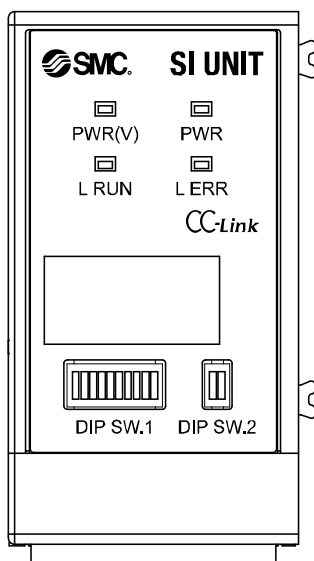

Figure 4

\*: Communication connector FG and FG terminal are connected inside the SI unit.  
Ground one of the terminals with the ground resistance of 100 Ω or less.

## LED Indication and Settings

### oLED Indication



LED	Description	LED status
PWR(V)	Solenoid valve power supply is supplied at specified voltage	ON
	Solenoid valve power supply is not supplied at specified voltage	OFF
PWR	SI unit power supply supplied within the specified range	ON
	SI unit power supply not connected or out of range	OFF
L RUN	Normal communication	ON
	Communication terminated (Time over error)	OFF
L ERR	Communication error	ON
	Address or communication speed changed during operation	Flashing
	Normal communication	OFF

○Switch setting

Turn off the power supply while setting the DIP switches.

Open the cover and set the DIP switches with a small flat blade screwdriver.

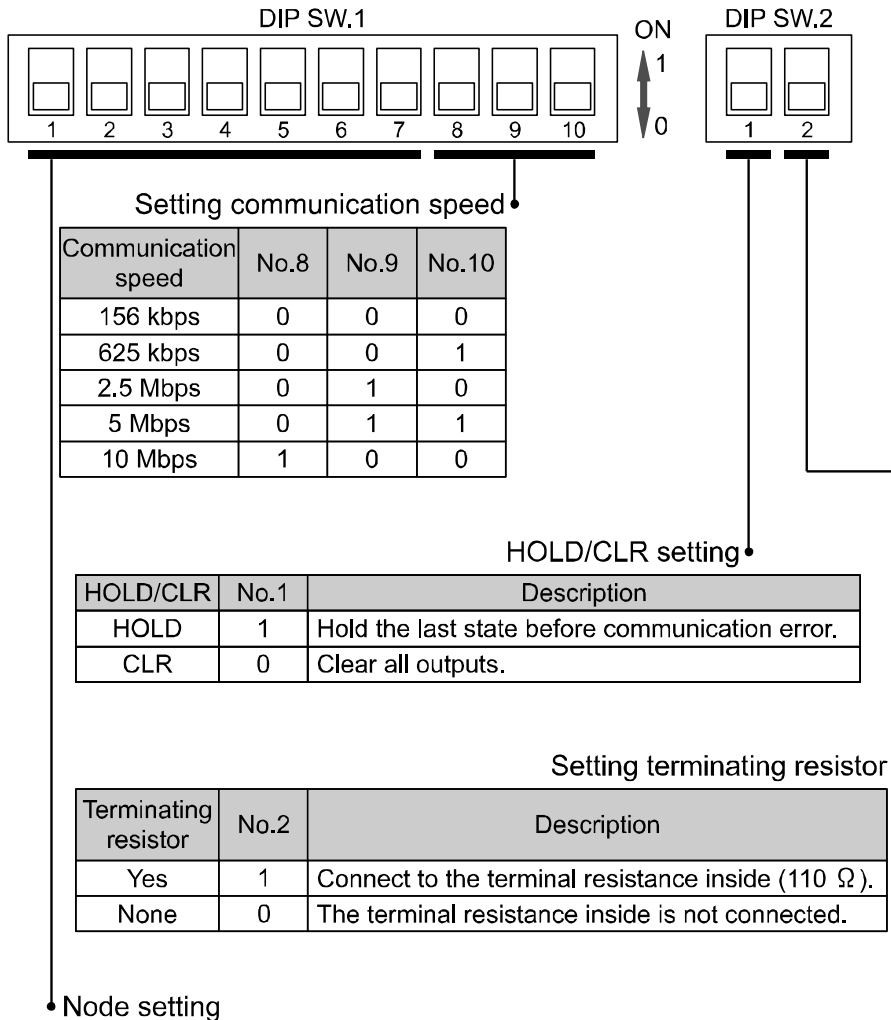

●Node setting

Node	X10 (Switch No.)			X1 (Switch No.)			
	40 (No.1)	20 (No.2)	10 (No.3)	8 (No.4)	4 (No.5)	2 (No.6)	1 (No.7)
1	0	0	0	0	0	0	1
2	0	0	0	0	0	1	0
3	0	0	0	0	0	1	1
:	:	:	:	:	:	:	:
63	1	1	0	0	0	1	1
64	1	1	0	0	1	0	0

○Output information

**I/O mapping table for master station Buffer Memory.**

EX180-SMJ3□/5□ is a remote I/O station (1 station occupied, 32 inputs/32 outputs).

An example of when the SI unit station number is set to 01 is shown below.

Master station buffer area

e.g.: "QJ61BT11N"

Node number	Buffer memory address	Remote input (RX)	Buffer memory address	Remote output (RY)
1	E0H	RX0F to RX00	160H	RY0F to RY00
	E1H	RX1F to RX10	161H	RY1F to RY10
2	E2H	RX2F to RX20	162H	RY2F to RY20
	E3H	RX3F to RX30	163H	RY3F to RY30
3	E4H	RX4F to RX40	164H	RY4F to RY40
	E5H	RX5F to RX50	165H	RY5F to RY50
4	E6H	RX6F to RX60	166H	RY6F to RY60
	E7H	RX7F to RX70	167H	RY7F to RY70
5	E8H	RX8F to RX80	168H	RY8F to RY80
	E9H	RX9F to RX90	169H	RY9F to RY90
6	EAH	RXAF to RXA0	16AH	RYAF to RYA0
	EBH	RXBF to RXB0	16BH	RYBF to RYB0
⋮	⋮	⋮	⋮	⋮

I/O memory map of EX180-SMJ3□/5□  
(For station number 1)

Remote input (RX)		Remote output (RY)	
RX00	Unused	RY00	Output No.0
		RY01	Output No.1
		RY02	Output No.2
⋮	⋮	⋮	⋮
RX0F	Unused	RY0D	Output No.13
		RY0E	Output No.14
		RY0F	Output No.15
RX10	Unused	RY10	Output No.16
		RY11	Output No.17
		RY12	Output No.18
⋮	⋮	⋮	⋮
RX1F	Unused	RY1D	Output No.29
		RY1E	Output No.30
		RY1F	Output No.31

Unused area cannot be used.

When remote I/O station is assigned to master station buffer area, the area of 32 inputs/32 outputs will be used.

0: Solenoid valve OFF

1: Valve ON

○Output number assignment

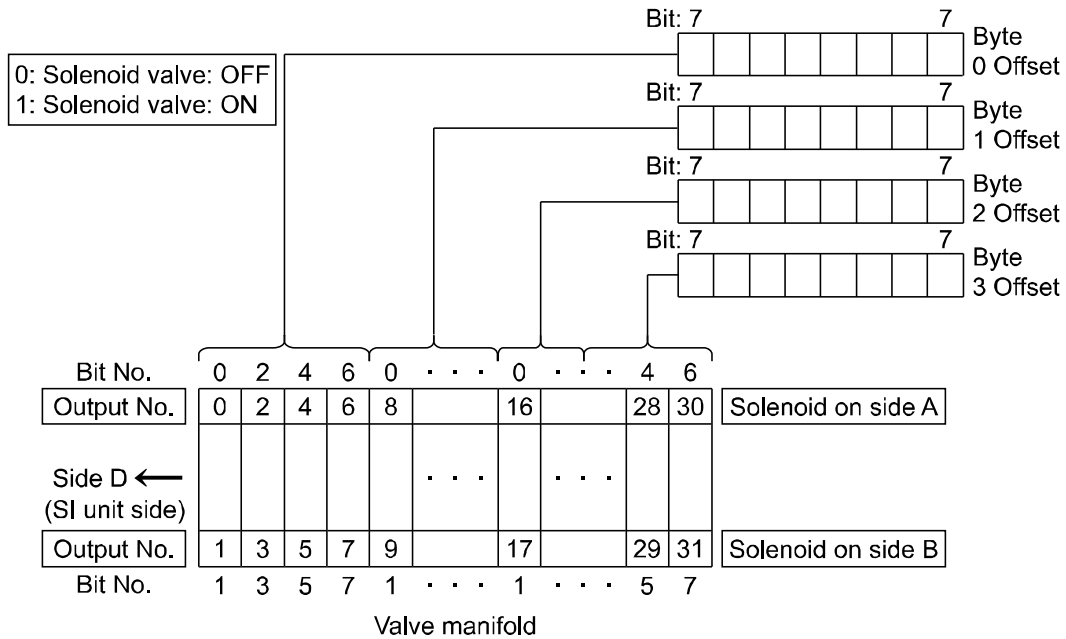

- \*: The output number refers to the solenoid position on the manifold and starts at zero.
- \*: Standard wiring on the manifold is for double-solenoid valves and output number starts A side and B side in that order as shown in the Figure a.  
If you mount a single-solenoid valve on the standard wiring manifold, output number for B side valve is skipped.
- \*: Custom wiring for mixed mounting single-solenoid valves and double-solenoid-valves can be specified with a Wiring Specification Sheet. For the SJ series valve manifold, the single or double wiring specification can be selected according to the solenoid type. (Figure b)
- \*: Bit status "0" and "1" on a data corresponds solenoid valve status ON and OFF (0: OFF, 1: ON), and output number starts at zero from LSB (least significant bit).

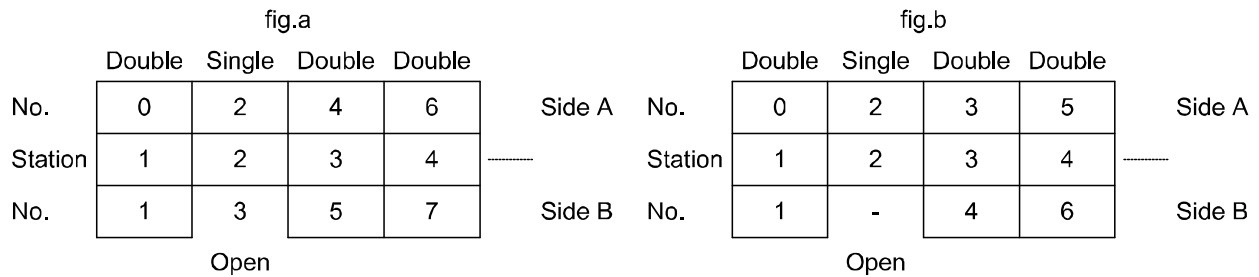



# Troubleshooting and Maintenance

## ○ Troubleshooting Chart

**Applicable SI unit: EX180-SMJ3□/5□**

When any malfunction is observed, perform the following troubleshooting.

When the troubleshooting does not apply to your problem and the operation returns to normal after replacing the SI unit, it is presumed that SI unit has malfunctioned. It may be possible that the malfunctioning of the SI unit is caused by the operating environment (network structure). Please consult SMC if further troubleshooting is necessary.

If the cause of the problem is not found using the troubleshooting provided below, it is presumed that the parameter setting of the master station and the network structure are inconsistent. In this case, please refer to the Troubleshooting section of the CC-Link master unit.

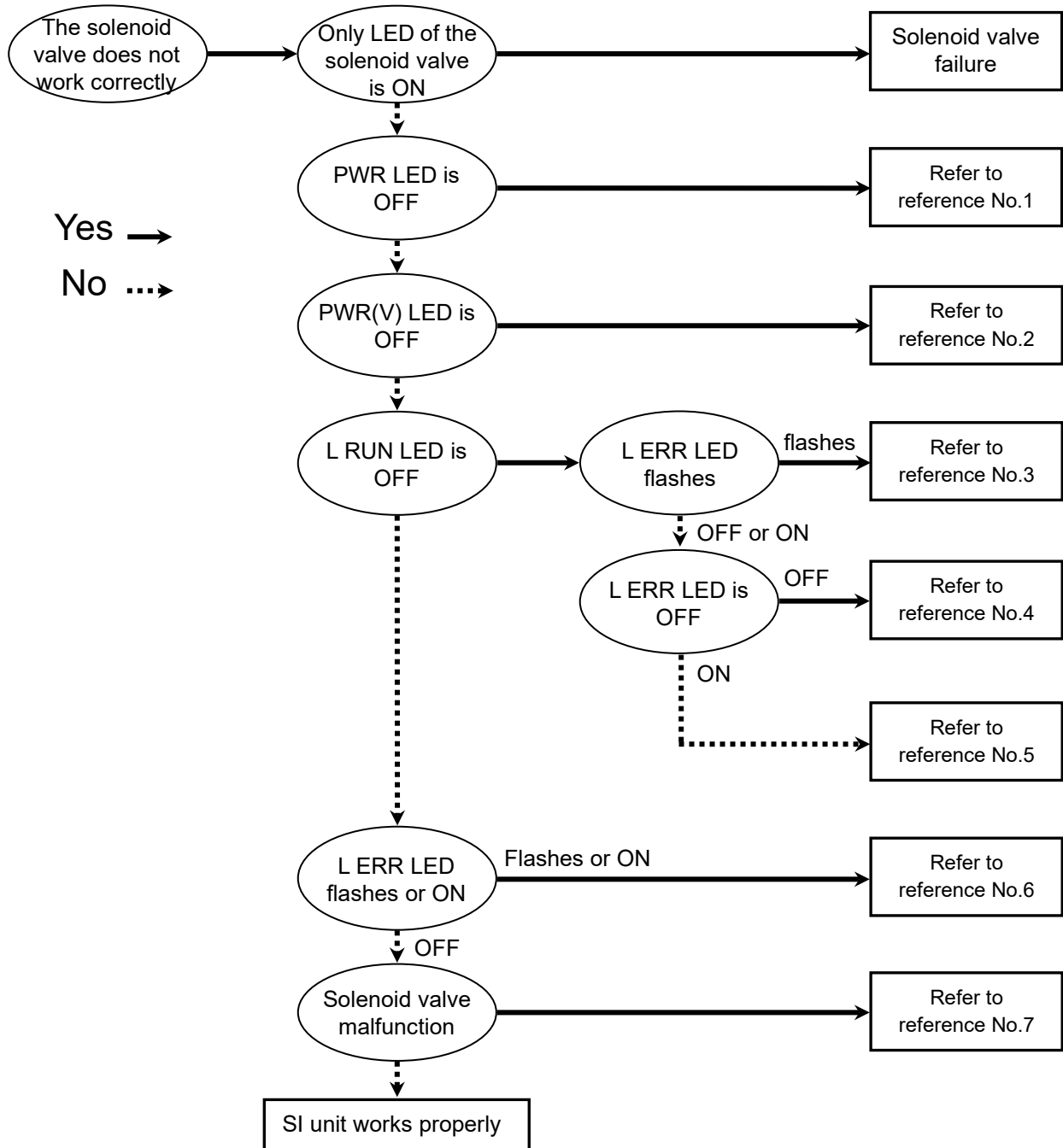

○Cross-Reference for Troubleshooting

Reference No.	Problem		Possible cause	Investigation method	Countermeasure
1	PWR LED is OFF		Incorrect wiring of the power supply for control of the SI unit	Check the cable for the power supply controlling the SI unit, and confirm that the connection between the power supply cable and the connector is not loose. Confirm that repeated bending stress or pulling force which can cause a broken wire is not applied to the cable.	Connect the power supply cable correctly.
				Confirm the wiring of the power supply for the SI unit.	Wire correctly.
			Incorrect power supply for the SI unit control.	Confirm the power supply voltage.	Supply 24 VDC $\pm$ 10% to the power supply for the SI unit control.
2	PWR(V) LED is OFF		Wiring failure of the power supply for the solenoid valve	Check the cable for the solenoid valve is not broken, and confirm that the connection between the power supply cable and the connector is not loose. Confirm that repeated bending stress or pulling force which can cause a broken wire is not applied to the cable.	Connect the power supply cable correctly.
				Confirm the wiring of the power supply for the solenoid valve is correct.	Wire correctly.
			Failure of the power supply for the solenoid valve	Confirm the supply voltage for the power supply for the solenoid valve.	Supply 24 VDC +10/-5% for the power supply for the solenoid valve.
3	L RUN LED is OFF	L ERR LED flashes	Incorrect wiring length or terminal resistance	Check the network length is acceptable for the communicating speed, the presence of termination at both ends, and suitable CC-Link cable has been used.	Wire and set correctly.
			Incorrect setting change of the communication speed	Confirm the communication speed setting has not been changed whilst power was supplied to the SI unit.	Shut off the power supply for the SI unit. After setting correctly supply power to the SI unit.
			Incorrect setting change of the node number.	Confirm the node number setting was not changed whilst power was supplied to the SI unit.	
			Communication failure	Check that there is no equipment or high voltage line that can generate noise around the communication and power supply lines.	Keep the communication and power supply cables away from the noise source.

Reference No.	Problem		Possible cause	Investigation method	Countermeasure
4	L RUN LED is OFF	L ERR LED is OFF	Failure of the power supply for the master station	Confirm that power is supplied to the master station	Supply power to the master station correctly.
			Communication line wiring failure	Check the communication cable is not broken, and that there are no loose connections between the power supply cable and connector. Confirm that repeated bending stress or pulling force which can cause a broken open wire is not applied to the cable.	Connect the communication cable correctly.
				Check proper wiring of the communication cable.	Wire correctly.
			Communication failure	Check that there is no equipment or high voltage line that can generate noise around the communication and power supply lines.	Keep the communication and power supply cables away from the noise source.
			Incorrect node number	Confirm the node number setting and the station information set in the master station is correct.	Set correctly.
			Communication speed setting is incorrect.	Confirm that the communication speed setting of the SI unit and the communication speed setting of the master are the same.	
5	L RUN LED is OFF	L ERR LED is ON	Incorrect node number setting. Incorrect node number duplication	Confirm the node number setting of the SI unit and the node number setting has not been duplicated.	Set correctly.
			Incorrect communication speed setting.	Confirm the SI unit communication speed setting is correct.	

Reference No.	Problem		Possible cause	Investigation method	Countermeasure
6	L RUN LED is ON	L ERR LED flashes	Incorrect change of the communication speed	Confirm the communication speed setting has not been changed whilst power is supplied to the SI unit.	Shut off the power supply for the SI unit. After setting correctly supply power to the SI unit.
			Incorrect change of the node number.	Confirm the node number setting has not been changed whilst power is supplied to the SI unit.	
			Communication failure	Check that there is no equipment or high voltage line that can generate noise around the communication and power supply lines.	
7	Solenoid valve malfunction		Solenoid valve failure	Check the operation by replacing the solenoid valve. Or refer to Troubleshooting for the solenoid valve.	Check the Troubleshooting for the solenoid valve. Or contact to the department in charge of the solenoid valve
			Connection between SI unit and valve manifold is defective	Check that there is no contact failure such as bending of the connector pins between the SI unit and valve manifold	Connect the SI unit and valve manifold properly.
			More than 33 valves are connected	Check the total number of solenoid valves connected to the manifold is 32 or less.	Ensure the total number of solenoid valves is 32 or less.

## ■ Maintenance

### ● Mounting/Wiring

Item	Criterion	Remedy
Check the SI unit connector for the communication and the power supply are connected properly.	Not loose.	Perform extra tightening. (Refer to "Wiring" of this operation manual)
Confirm that the terminal resistor is properly connected to both ends of the CC-Link network.	Not loose.	Perform extra tightening.
Confirm that the connection cable is not broken.	No problem on the appearance.	If any problem is confirmed from the appearance, replace the cable.

### ● Hardware

Item	Criterion	Remedy
Cable for moving parts (If the cable is used)	No problem is found on the appearance or the conductor resistance value. (Confirm that the resistance value does not exceed the specification)	If any visible problem is found or the conductor resistance value is out of specification, replace the cable. Please refer to the specification of the cable for the conductor resistance.
SI unit	No abnormal operation or LED display.	Replace the SI unit if the operation or LED display is abnormal.

### ● Power supply

Item	Criterion	Remedy
Measure the voltage at both ends of the power supply for the SI unit and check if the voltage is within the specified range.	24 VDC $\pm$ 10%	Investigate the cause of voltage fluctuation and fix the problem.
Measure the voltage at both ends of the solenoid valve power supply and check if the voltage is within the specified range.	24 VDC +10/-5%	Investigate the cause of voltage fluctuation and fix the problem.

# Specifications

## ■ Table of specifications

Item		Specifications				
Network communication specifications	Applicable system	CC-Link Ver.1.10				
	Occupied number of stations	1 node				
	Allowable node number setting	1 to 64				
	Station type	Remote I/O node				
	Transmission speed	156 kbps	625 kbps	2.5 Mbps	5 Mbps	10 Mbps
	Min. cable length between nodes	20 cm or more				
	Max. total cable length	1200 m	900 m	400 m	160 m	100 m
Rated voltage		24 VDC				
Power supply voltage range		Power supply for SI unit: 24 VDC $\pm$ 10% Power supply for the solenoid valves: 24 VDC +10/-5% (Voltage drop warning is generated at approximately 20 V)				
Current consumption		Power supply for SI unit: 0.1 A or less Power supply for the solenoid valves				
Output specification	Output type	EX180-SMJ3□: NPN (positive common)/sink EX180-SMJ5□: PNP (negative common)/source				
	Number of outputs	32 points				
	Connection load	Solenoid valve with surge voltage suppressor of 24 VDC and 1 W or less (manufactured by SMC)				
	Output setting at the time of communication error	Hold/Clear (Switch setting)				
Environment	Enclosure	IP20				
	Withstand voltage	500 VAC 1 min. (Between FG and external terminal)				
	Insulation resistance	10 M $\Omega$ or more (500 VDC, Between FG and external terminal)				
	Ambient temperature	Working temperature: -10 to +50 °C Storage: -20 to +60 °C				
	Ambient humidity	35 to 85%RH (Non condensing)				
	Operating atmosphere	No corrosive gas				
Standard		UL/CSA (E209424), CE/UKCA marked				
Weight		110 g or less (Including accessories)				

# Dimensions

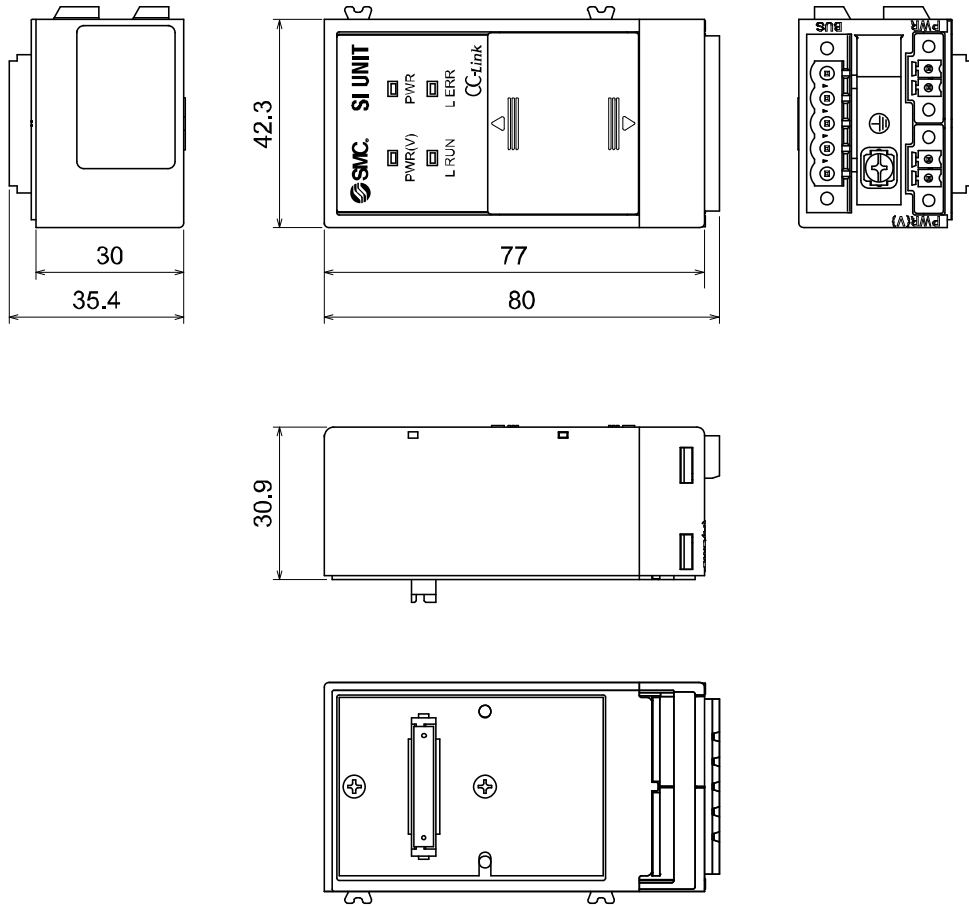

Unit: mm

EX180-SMJ3/5

EX180-SMJ3A/5A

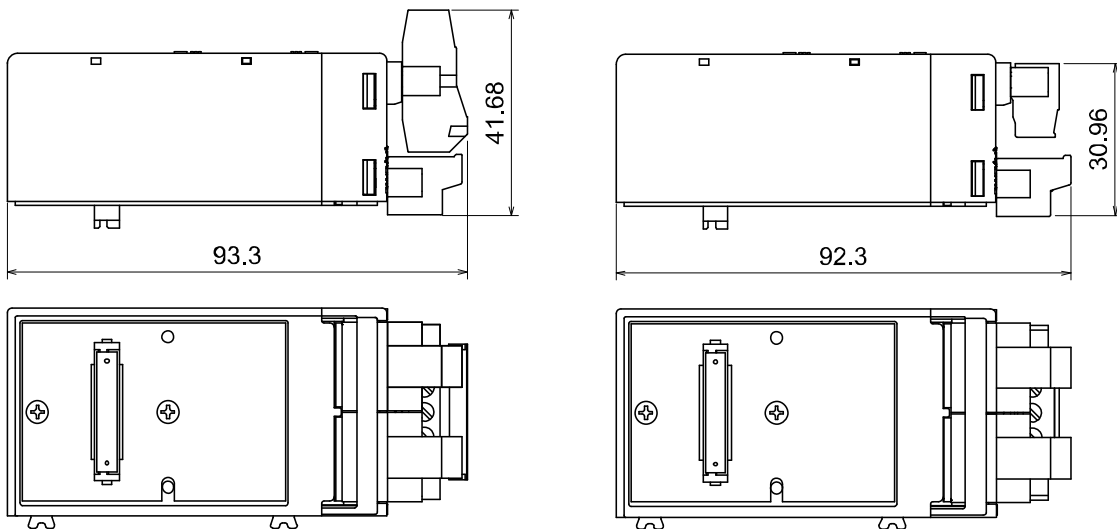

#### Revision history

A: Revision  
B: Limited warranty and Disclaimer are added.  
C: Contents are added.  
D: Contents are added. [June 2017]  
E: Contents revised in several places.  
[January 2021]  
F: Contents revised in several places [May 2024]

## SMC Corporation

Tel: + 81 3 5207 8249 Fax: +81 3 5298 5362  
URL <https://www.smcworld.com>

---

Note: Specifications are subject to change without prior notice and any obligation on the part of the manufacturer.  
© SMC Corporation All Rights Reserved

