



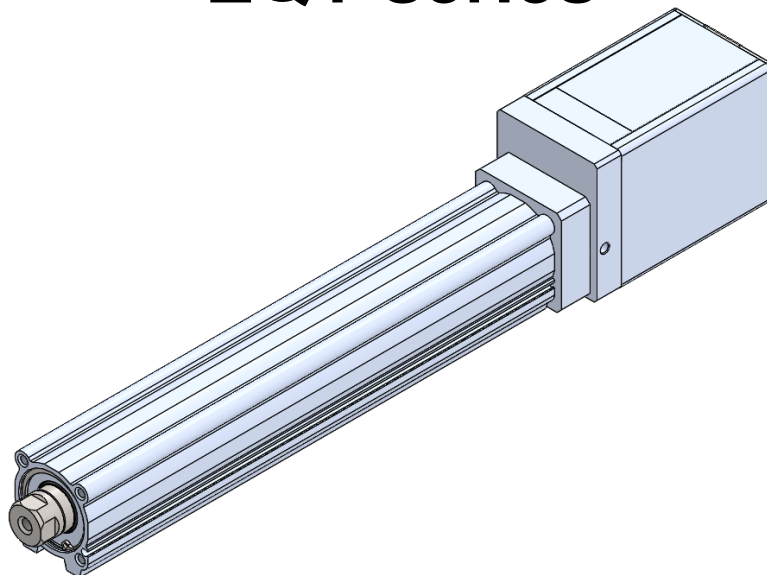
# Operation Manual

PRODUCT NAME

## ***e-Actuator / Rod type*** ***Electric Actuator*** ***Easy to Operate Integrated Controller*** ***(Servo 24VDC)***

Model / Series / Product Number

### **EQY series**



Also refer to the e-Actuator setup software(e-Actuator setup tool)instruction manual.  
Please download this software from our website.  
<http://www.smcworld.com/>

## **SMC Corporation**

<b>Safety Instructions</b> .....	<b>3</b>
Precautions for product specific.....	5
<b>1 Outlines of Product</b> .....	<b>24</b>
1.1 System Construction Example.....	24
1.2 Features.....	25
1.3 How to Order.....	26
1.4 Specification Table.....	27
1.5 Construction.....	29
1.6 Accessories.....	30
<b>2 Installation and Initial Setting</b> .....	<b>31</b>
2.1 Flow from installation to initial setting.....	31
2.2 Check the contents of the package.....	32
2.3 Preparation of necessary supplies.....	33
2.4 Installation of electric actuators.....	34
2.5 Wiring and Connection.....	35
2.5.1 Connection to input power supply.....	35
2.5.2 Connection to PC.....	40
2.5.3 Connection to PLC.....	40
2.6 Power ON alarm (error).....	42
2.7 Setup of the operation parameters.....	42
2.8 Test run.....	43
<b>3 Operation</b> .....	<b>44</b>
3.1 Operation flow.....	44
3.2 Procedure for power set up.....	45
3.2.1 Procedure for power start up.....	45
3.2.2 Power Supply Startup.....	45
3.3 Operation Instructions.....	47
3.3.1 Outline of operation command.....	47
3.3.2 Positioning operation.....	47
3.3.3 Pushing operation.....	50
3.3.4 Reset.....	53
3.4 Operation Examples.....	54
3.4.1 Positioning operation.....	54
3.4.2 Pushing operation.....	55
<b>4 Operation Mechanism</b> .....	<b>56</b>

4.1	Positioning operation .....	56
4.2	Pushing operation .....	56
4.3	Return to origin .....	58
4.4	Response time in receiving an electric actuator input signal .....	59
4.5	Methods of interrupting operation .....	59
<b>5</b>	<b>Alarm detection .....</b>	<b>60</b>
5.1	Parallel signal output for the alarm group .....	60
5.2	Alarm details .....	60
<b>6</b>	<b>Troubleshooting .....</b>	<b>64</b>
<b>7</b>	<b>Specifications .....</b>	<b>69</b>
7.1	Basic specifications of the product .....	69
7.2	Parts Description .....	70
7.3	Power supply connector Specification .....	71
7.4	I/O Connector specifications .....	72
7.4.1	Details of parallel input/output signals .....	72
7.4.2	Parallel input/output specification .....	74
7.4.3	Parallel input/output type circuit (NPN and PNP) .....	74
<b>8</b>	<b>Setting .....</b>	<b>75</b>
8.1	Operation data .....	75
8.2	Parameter .....	77
<b>9</b>	<b>Optional parts (sold separately) .....</b>	<b>79</b>
9.1	Power supply cable .....	79
9.2	I/O cable .....	79
9.3	Setup communication cable .....	80
9.4	Configuration software .....	80



# e-Actuator/ Rod Type Safety Instructions

These safety instructions are intended to prevent hazardous situations and/or equipment damage. These instructions indicate the level of potential hazard with the labels of “Caution,” “Warning” or “Danger.”

They are all important notes for safety and must be followed in addition to International Standards (ISO/IEC)\*1), and other safety regulations.

\*1) ISO 4414: Pneumatic fluid power - General rules and safety requirements for systems and their components  
ISO 4413: Hydraulic fluid power - General rules and safety requirements for systems and their components  
IEC 60204-1: Safety of machinery - Electrical equipment of machines - Part 1: General requirements  
ISO 10218-1: Robots and robotic devices - Safety requirements for industrial robots - Part 1: Robots etc.



## **Danger**

**Danger** indicates a hazard with a high level of risk which, if not avoided, will result in death or serious injury.



## **Warning**

**Warning** indicates a hazard with a medium level of risk which, if not avoided, could result in death or serious injury.



## **Caution**

**Caution** indicates a hazard with a low level of risk which, if not avoided, could result in minor or moderate injury.

## **Warning**

### **1. The compatibility of the product is the responsibility of the person who designs the equipment or decides its specifications.**

Since the product specified here is used under various operating conditions, its compatibility with specific equipment must be decided by the person who designs the equipment or decides its specifications based on necessary analysis and test results.

The expected performance and safety assurance of the equipment will be the responsibility of the person who has determined its compatibility with the product.

This person should also continuously review all specifications of the product referring to its latest catalog information, with a view to giving due consideration to any possibility of equipment failure when configuring the equipment.

### **2. Only personnel with appropriate training should operate machinery and equipment.**

The product specified here may become unsafe if handled incorrectly.

The assembly, operation and maintenance of machines or equipment including our products must be performed by an operator who is appropriately trained and experienced.

### **3. Do not service or attempt to remove product and machinery/equipment until safety is confirmed.**

1. The inspection and maintenance of machinery/equipment should only be performed after measures to prevent falling or runaway of the driven objects have been confirmed.

2. When the product is to be removed, confirm that the safety measures as mentioned above are implemented and the power from any appropriate source is cut, and read and understand the specific product precautions of all relevant products carefully.

3. Before machinery/equipment is restarted, take measures to prevent unexpected operation and malfunction.

### **4. Our products cannot be used beyond their specifications. Our products are not developed, designed, and manufactured to be used under the following conditions or environments. Use under such conditions or environments is not covered.**

1. Conditions and environments outside of the given specifications, or use outdoors or in a place exposed to direct sunlight.

2. Use for nuclear power, railways, aviation, space equipment, ships, vehicles, military application, equipment affecting human life, body, and property, fuel equipment, entertainment equipment, emergency shut-off circuits, press clutches, brake circuits, safety equipment, etc., and use for applications that do not conform to standard specifications such as catalogs and operation manuals.

3. Use for interlock circuits, except for use with double interlock such as installing a mechanical protection function in case of failure. Please periodically inspect the product to confirm that the product is operating properly.



# e-Actuator/ Rod Type Safety Instructions

## Caution

**We develop, design, and manufacture our products to be used for automatic control equipment, and provide them for peaceful use in manufacturing business.**

**Use in non-manufacturing business is not covered.**

Products we manufacture and sell cannot be used for the purpose of transactions or certification specified in the Measurement Act.

The new Measurement Act prohibits use of any unit other than SI units in Japan.

## Limited warranty and Disclaimer/Compliance Requirements

The product used is subject to the following “Limited warranty and Disclaimer” and “Compliance Requirements”.

Read and accept them before using the product.

### Limited warranty and Disclaimer

1. The warranty period of the product is 1 year in service or 1.5 years after the product is delivered, whichever is first.\*2)

Also, the product may have specified durability, running distance or replacement parts. Please consult your nearest sales branch.

2. For any failure or damage reported within the warranty period which is clearly our responsibility, a replacement product or necessary parts will be provided.

This limited warranty applies only to our product independently, and not to any other damage incurred due to the failure of the product.

3. Prior to using SMC products, please read and understand the warranty terms and disclaimers noted in the specified catalog for the particular products.

\*2) Vacuum pads are excluded from this 1 year warranty.

A vacuum pad is a consumable part, so it is warranted for a year after it is delivered.

Also, even within the warranty period, the wear of a product due to the use of the vacuum pad or failure due to the deterioration of rubber material are not covered by the limited warranty.

### Compliance Requirements

1. The use of SMC products with production equipment for the manufacture of weapons of mass destruction(WMD) or any other weapon is strictly prohibited.

2. The exports of SMC products or technology from one country to another are governed by the relevant security laws and regulation of the countries involved in the transaction. Prior to the shipment of a SMC product to another country, assure that all local rules governing that export are known and followed.

## Precautions for product specific

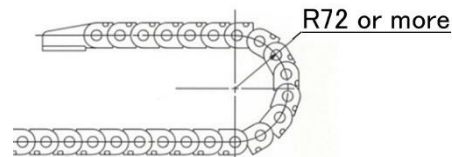
### Precautions for wiring and cable

#### Warning

- ① **Installation, adjustment, inspection, or wiring changes should be conducted with the power supply to this product turned OFF.**  
Electrical shock, malfunction, or damage can result.
- ② **Never disassemble the cable.**
- ③ **Never connect or disconnect the cable or connector with the power ON.**

#### Caution

- ① **Wire the connector securely.**  
Do not apply any voltage to the terminals other than those specified in the Operation Manual.
- ② **Wire the connector correctly.**  
Check for correct connector wiring and polarity.
- ③ **Take appropriate measures against noise.**  
Noise in a signal line may cause malfunction.  
As a countermeasure, high voltage and low voltage cables should be separated, and keep wiring lengths short, etc.
- ③ **Do not connect power or high-voltage cables in the same wiring path as the unit.**  
The product can malfunction due to noise and surge voltage interference in the signal line from power and high-voltage cables. Separate the wiring of the electric actuator and its peripheral device from that of power and high-voltage cables.
- ⑤ **Take care that actuator movement does not damage cables.**
- ⑥ **Operate with cables secured.**  
Avoid bending cables at sharp angles where they enter the electric actuator.
- ⑦ **Avoid twisting, folding, rotating, or applying external force to the cable.**  
Electric shock, wire breakage, contact failure, or a loss of product control may occur.
- ⑧ **Fix the Communication cable for setting in place before using.**  
Communication cable for setting is not a robotic type cable and can be damaged when moved.
- ⑨ **When repeatedly bending power or I/O cables, do not place them in a flexible moving tube with a radius smaller than the specified value (72mm minimum).**  
If the product is repeatedly bent, please check periodically for cable disconnection and contact failure.



#### ⑩ **Confirm wiring insulation.**

Poor insulation (interference with other circuits, poor insulation between terminals etc.) can apply excessive voltage or current to the product causing damage.

- ⑪ **The electric actuator speed and force may change depending on the cable length, load, and mounting conditions.**  
Furthermore, if the cable length exceeds 5 m, then it will decrease by up to 10% for every additional 5 m. (If cable length is 15m: Maximum 20% reduction.)
- ⑫ **When checking the conductivity of the cable, be careful not to deform the connector's mating hole and terminals.**  
Inserting a non-compatible connector, tool, cylinder-shaped object, etc., into the connector's mating hole can cause the mating hole or terminals to become deformed, which may cause contact failure or disconnection.
- ⑬ **Refrain from plugging in and unplugging the connector frequently.**  
Doing so may result in contact failure or disconnection.
- ⑭ **Do not connect wires while the power is ON.**  
It may cause the electric actuator or its peripheral devices to be damaged, causing a malfunction.

## 【Transportation】



### Caution

- ① **Do not carry or swing the product by the cable or motor.**

## Electric Actuators / Common Precautions

### ■ Design



### Warning

- ① **Be sure to read this Operation Manual.**  
Handling or operation other than that specified in this Operation Manual may lead to damage or product failure.  
Any damage attributed to the use beyond the specifications is not guaranteed.
- ② **There is a possibility of dangerous sudden action by the product if sliding parts of machinery are twisted due to external forces etc.**  
In such cases, human injury may occur, such as by catching hands or feet in the machinery, or damage to the machinery itself may occur. Design the machinery to avoid such dangers.
- ③ **A protective cover is recommended to minimize the risk of personal injury.**  
If a driven object and moving parts of the product are in close proximity, personal injury may occur. Design the system to avoid contact with the human body.
- ④ **Securely tighten all stationary parts and connected parts so that they will not become loose.**  
When the product operates with high frequency or is installed where there is a lot of vibration, ensure that all parts remain secure.
- ⑤ **Consider a possible loss of power source.**  
Take measures to prevent injury and equipment damage even in the case of a power source failure.
- ⑥ **Consider behavior of emergency stop of whole system.**  
Design the system so that human injury and/or damage to machinery and equipment will not be caused when it is stopped by a safety device for abnormal conditions such as a power outage or a manual emergency stop of whole system.
- ⑦ **Consider the action when operation is restarted after an emergency stop or abnormal stop of whole system.**  
Design the system so that human injury or equipment damage will not occur upon restart of operation of whole system.
- ⑧ **Never disassemble or modify (including additional machining) the product.**  
An injury or failure can result.  
It will cause the loss of the product performance.

- ⑨ **Do not use the stop signal as the emergency stop of the system.**  
Stop by shutdown of M24V is for stopping the electric actuator with deceleration.  
For the emergency stop of the equipment, design the system with a separate emergency stop circuit conforming to relevant safety standards.
- ⑩ **When using the electric actuator for vertical applications, it is necessary to build in a safety device.**  
The rod may fall due to the weight of work. The safety device should not interfere with normal operation of the machine.
- ⑪ **Do not exceed the product specifications even if a work load is supported by external guides.**  
Although the Electric actuator moment is reduced by the external guides, the required trans- port ability (the relationship between the speed and the work load) is not reduced.
- ⑫ **In order to prevent danger and damage due to the breakdown and the malfunction of this product, which may occur at a certain probability, a backup system should be established in advance by giving a multiple-layered structure or a fail-safe design to the equipment, etc.**
- ⑬ **Avoid designing a system that allows the driving part of an electric actuator to operate with a spring or other external force.**

### **Caution**

- ① **Operate within the limits of the maximum usable stroke.**  
The product will be damaged if it is used with a stroke which exceeds the maximum stroke. Refer to the specifications of the product.
- ② **When the product repeatedly cycles with partial strokes, operate it at a full stroke at least once a day or every 1000 strokes.**  
Otherwise, lubrication can be lost.
- ③ **Do not use the product in applications where excessive external force or impact force is applied to it.**  
The product can be damaged. The components, including the motor, are manufactured to precise tolerances. Even a slight deformation may cause a malfunction or seizure.
- ④ **Refer to the Auto Switches Precautions (Best Pneumatics No②) if an auto switch is to be built in and used.**
- ⑤ **When UL compliance is required, the electric actuator and controller/driver should be used with a UL1310 class 2 power supply.**
- ⑥ **Do not exceed the product specifications even if a work load is supported by external guides.**  
Although the actuator moment is reduced by external guides, the required trans- port ability (the relationship between the speed and the work load) is not reduced.

## ■ **Mounting**

### **Warning**

- ① **Install and operate the product only after reading this Operation Manual carefully and understanding its contents. Keep the manual in a safe place for future reference.**
- ② **Observe the tightening torque for screws.**  
Tighten the screws to the recommended torque for mounting the product.
- ③ **Do not make any alterations to this product.**  
Alterations made to this product may lead to a loss of durability and damage to the product, which can lead to human injury and damage to other equipment and machinery.
- ④ **Make sure to connect the piston rod and the load so that their axial centers and movement directions match.**



There will be damage/excessive wear on the lead screw if the external guide is not parallel.

- ⑤ **When an external guide is used, connect the moving parts of the product and the load in such a way that there is no interference at any point within the stroke.**  
Do not scratch or damage the sliding part by hitting it with an object. Components are manufactured to precise tolerances, so the slightest deformation may cause faulty operation.
- ⑤ **Prevent the seizure of rotating parts (pins, etc.) by applying grease.**
- ⑥ **Do not use the product until it is verified that the equipment can operate properly.**  
After mounting or repair, connect the power supply to the product and perform appropriate functional inspections to check it is mounted correctly.
- ⑧ **When one side is fixed**  
When an actuator is operated at a high speed with one end fixed and the other free (basic, flange, or direct mount types), a bending moment may act on the actuator due to the vibration generated at the stroke end, which can damage the actuator. In such a case, install a mounting bracket to suppress the vibration of the actuator body, or reduce the speed so that the actuator does not vibrate. Also, use a mounting bracket when moving the actuator body or when a long stroke actuator is mounted horizontally and fixed at one end.
- ⑨ **When mounting the actuator or attaching the work piece, do not apply strong impact or large moment.**  
If an external force above the allowable moment is applied, it may cause looseness in the guide unit, an increase in sliding resistance or other problems.
- ⑨ **Maintenance space**  
Allow sufficient space around the product for maintenance and inspection.
- ⑪ **The electric actuator and its peripheral devices should be installed on a fire-proof material.**  
Direct installation on or near a flammable material may cause a fire.
- ⑫ **Do not install the product in a place subject to vibrations and impacts.**  
It will cause failure or malfunction.
- ⑬ **Take measures to ensure that the operating temperatures of the electric actuator and its peripheral devices are within the range of the specifications.**  
**also should be installed with 50mm or larger spaces between each side of it and the other structures or components.**  
It may cause a malfunction of the controller and its peripheral devices and a fire.
- ⑭ **Do not mount the controller and its peripheral devices near a large electromagnetic contactor or no-fuse breaker which generates vibration on the same panel. Mount them on different panels, or keep the controller and its peripheral devices away from such a vibration source.**
- ⑮ **Install the electric actuator and its peripheral devices on a flat surface.**  
If the mounting surface is distorted or uneven, an unacceptable force may be added to the housing, etc., causing problems.

## ■ Handling

### Warning

- ① **Do not touch the motor while in operation.**  
The surface temperature of the motor can increase to approx. 80°C due to operating conditions. Energizing alone may also cause this temperature increase. Do not touch the motor when in operation as it may cause burns.
- ② **If abnormal heating, smoking or fire, etc., occurs in the product, immediately turn OFF**

the power supply.

- ③ **Immediately stop operation if abnormal noise or vibration occurs.**  
If abnormal operation noise or vibration occurs, the product may have been mounted incorrectly. Unless operation of the product is stopped for inspection, the product can be seriously damaged.
- ④ **Never touch the rotating part of the motor or moving part of the actuator while in operation.**
- ⑤ **When installing, adjusting, inspecting or performing maintenance on the product and related equipment, be sure to turn off the power supply to them. Then, lock it so that no one other than the person working can turn the power on, or implement measures such as a safety plug.**
- ⑥ **The inside of the electric actuator and its connector should not be touched.**  
It may cause an electric shock or damage to the controller.
- ⑦ **Do not perform the operation or setting of the product with wet hands.**  
Doing so may cause an electric shock.
- ⑧ **Products with damage or those missing any components should not be used.**  
An electric shock, fire, or injury may result.
- ⑨ **Be careful not to be caught or hit by the workpiece while the electric actuator is moving.**  
It may cause an injury.
- ⑩ **Do not connect the power supply to the product before confirming the area to which the work-piece moves is safe.**  
The movement of the workpiece may cause an accident.
- ⑪ **Before installation, wiring, and maintenance, the voltage should be checked with a tester 5 minutes after the power supply has been turned off.**  
Otherwise, an electric shock, fire, or injury may result.
- ⑫ **Do not use the product in an area where dust, powder, water, chemicals, or oil is in the air.**  
It will cause failure or malfunction.
- ⑬ **Do not use the product in an area where a magnetic field is generated.**  
It will cause failure or malfunction.
- ⑭ **Do not install the product in an environment containing flammable gas, explosive gas, or corrosive gas.**  
It could lead to fire, explosion and corrosion.
- ⑮ **Radiant heat from strong heat sources, such as a furnace, direct sunlight, etc., should not be applied to the product.**  
It will cause failure of the electric actuator or its peripheral devices.
- ⑯ **Do not use the product in an environment subject to a temperature cycle.**  
It will cause failure of the electric actuator or its peripheral devices.
- ⑰ **Do not use the product in a place where electrical surges are generated.**  
When there are units that generate a large amount of surge around the product (e.g. solenoid type lifters, high-frequency induction furnaces, motors, etc.), this may cause deterioration or damage to the product's internal circuit. Avoid sources of surge generation and crossed lines.
- ⑱ **Do not install the product in an environment under the effect of vibrations and impacts.**  
It will cause failure or malfunction.
- ⑲ **When a surge-generating load, such as a relay or solenoid valve, is driven directly, use a product that incorporates a surge protection device.**

**⚠ Caution**

- ① **Conduct the following inspection before operation.**
  - a) Confirm that the power supply line and each signal line is not damaged.
  - b) No play or looseness of the connectors to each power line and signal line
  - c) No play or looseness of the mounting
  - d) Confirm that the electric actuator/cylinder/controller/driver is operating correctly.
  - e) Confirm the function of the emergency stop of the whole system.
  
- ② **If several persons are to be working concurrently, determine the procedure, signs, measures against abnormality, and restarting measures in advance. Then, have someone else, supervise the work.**
  
- ③ **The product may operate at a speed different from the set speed depending on the load and resistance.**

When selecting a product, check the catalog for instructions regarding selection and specifications.
  
- ④ **Do not apply a load, impact, or resistance in addition to the transferred load during the return to origin.**

If the product is made to return to origin by pushing force, a displacement of the origin position may occur.
  
- ④ **Do not remove the product name plate.**
  
- ⑤ **Operation tests should be carried out at a low speed. Start operation using a predefined speed after confirming there are no problems.**
  
- ⑥ **Do not apply forces of impact, collision, or resistance to the moving parts of an actuator during operation.**

Doing so will cause a decrease in product life, damage to the product, etc.

**【Grounding】**

**⚠ Warning**

- ① **Ensure that the product is grounded to allow the noise tolerance of the electric actuator.**

Otherwise it may cause an electric shock or fire.
  
- ② **Dedicated grounding should be used.**

Grounding should be to a D-class ground. (Ground resistance 100Ω or less)
  
- ③ **The earth cable length should be as short as possible.**
  
- ④ **In the unlikely event that malfunction is caused by the ground connection, then it may be disconnected.**

■ **Power supply**

**⚠ Caution**

- ① **Use a power supply that has low noise between lines and between the power and ground.**

In cases where noise is high, an isolation transformer should be used.
  
- ② **The grounding point should be as near as possible to the electric actuator.**

If the power supply is of the “inrush-current control” type, a voltage drop may occur during the acceleration or deceleration of the actuator.
  
- ③ **Appropriate measures should be taken to prevent lightning surges. Ground the surge**

absorber for lightning separately from the grounding of the electric actuator and its peripheral devices.

## 【Unpackaging】

### Caution

① **Check the received product is as ordered.**

If a different product is installed from the one ordered, injury or damage can result.

## ■ Operating environment

### Warning

① **Avoid use in the following environments.**

1. Locations where a large amount of dust and cutting chips are airborne.
2. Locations where the ambient temperature is outside the range of the temperature specification (refer to specifications).
3. Locations where the ambient humidity is outside the range of the humidity specification (refer to specifications).
4. Locations where corrosive gas, flammable gas, sea water, water and steam are present.
5. Locations where strong magnetic or electric fields are generated.
6. Locations where direct vibration or impact is applied to the product.
7. Areas that are exposed to splashes of water and oil drops.
8. Areas exposed to direct sunlight (ultraviolet rays).
9. Environment at an altitude of 1000 meters or higher.  
Heat dissipation and withstand voltage will decrease. Contact SMC for details.

② **Do not use in an environment where the product is directly exposed to liquid, such as cutting oils.**

If cutting oils, coolant or oil mist contaminates the product, failure or increased sliding resistance can result.

③ **Install a protective cover when the product is used in an environment directly exposed to foreign matter such as dust, cutting chips and spatter.**

Play or increased sliding resistance can result.

④ **Shade the sunlight in the place where the product is applied with direct sunshine.**

⑤ **Shield the product if there is a heat source nearby.**

When there is a heat source surrounding the product, the radiated heat from the heat source can increase the temperature of the product beyond the operating temperature range.

⑥ **Grease oil can be reduced due to the external environment and operating conditions. The lubrication performance may deteriorate and shorten the life of the product.**

## 【Storage】

### Warning

① **Do not store the product in a place in direct contact with rain or water drops or is exposed to harmful gas or liquid.**

② **Store in an area that is shaded from direct sunlight and has a temperature and humidity within the specified range (-10°C to 60°C and 35% to 85% no condensation or freezing).**

③ **Do not apply vibration or impact to the product during storage.**

## ■ Maintenance

### Warning

① **Do not disassemble or repair the product.**

Fire or electric shock can result. Contact SMC, in case of disassembly for the maintenance.

② **Before modifying or checking the wiring, the voltage should be checked with a tester 5 minutes after the power supply is turned off.**

Electric shock can result.

- ③ **Install the electric actuator and its peripheral devices on a fire-proof material.**  
Direct installation on or near a flammable material may cause a fire.
- ④ **Do not install the product in a place subject to vibrations and impacts.**  
It will cause failure or malfunction.
- ⑤ **Take measure so that the operating temperature of this electric actuator and its peripheral devices are within the range of the specifications. Also, this electric actuator should be installed with 50mm or more between each side of it and other structures or components.**  
It may cause a malfunction of the controller and its peripheral devices or a fire.
- ⑥ **Do not mount the electric actuator and its peripheral devices near a large electromagnetic contactor or no-fuse breaker which generates vibration on the same panel. Mount them on different panels, or keep the electric actuator and its peripheral devices away from such a vibration source.**
- ⑦ **Install the electric actuator and its peripheral devices on a flat surface.**  
If the mounting surface is distorted or uneven, an unacceptable force may be added to the case, etc., causing problems.

#### **Caution**

- ① **Maintenance should be performed according to the procedure indicated in the Operation Manual.**  
Incorrect handling can cause an injury, damage or malfunction of equipment and machinery.
- ② **Removal of product**  
When equipment is serviced, first confirm that measures are in place to prevent dropping of work pieces and run-away of equipment, etc., and then cut the power supply to the system. When machinery is restarted, check that operation is normal with actuators in the proper positions.

#### **【Lubrication】**

##### **Caution**

- ① **The product has been lubricated for life at manufacture, and does not require lubrication in service.**  
Contact SMC if lubrication will be applied.

#### **■ Precautions for actuator with lock**

##### **Warning**

- ① **Do not use the lock as a safety lock or a control that requires a locking force.**  
The lock used for the product with a lock is designed to prevent dropping of the work piece.
- ② **For vertical mounting, use the product with a lock.**  
If the product is not equipped with a lock, the product will move and drop the work piece when the power is removed. If the actuator with lock is not used, preventative measure should be taken by the design of the equipment.
- ③ **"Measures against drops" means preventing a work piece from dropping due to its weight when the product operation is stopped and the power supply is turned off.**
- ④ **Do not apply an impact load or strong vibration while the lock is activated.**  
If an external impact load or strong vibration is applied to the product, the lock will lose its holding force and damage to the sliding part of the lock or reduced lifetime can result. The same situations will occur when the lock slips due to a force higher than its holding force, as this will accelerate the wear to the lock.
- ⑤ **Do not apply liquid or oil and grease to the lock or its surrounding.**  
When liquid or oil and grease are adhered to the sliding part of the lock, its holding force will reduce significantly. Or, lock sliding part performance and condition changes may cause a lock release malfunction.

- ⑥ **Take measures against drops and check that safety is assured before mounting, adjustment and inspection of the product.**  
If the lock is released with the product mounted vertically, a work piece can drop due to its weight.
- ⑦ **When the actuator is operated manually, supply 24VDC to the [LK RLS] terminal of the power supply connector.**  
If the product is manually operated without releasing the lock, wearing of the lock sliding surface will be increased, causing reduction in the holding force and the life of the locking mechanism.
- ⑧ **Do not supply 24VDC power supply constantly to the [LK RLS(Lock release)] terminal.**  
Only supply 24 VDC power supply to the [LK RLS(Lock release)] terminal during manual operation.  
If power is supplied to the [LK RLS] terminal continuously, the lock will be released, and workpieces may be dropped during stop condition.

## Electric actuators / Rod type - Common precautions

### ■ Design/ Selection

#### Caution

- ① **Do not apply a load in excess of the actuator specification.**  
A product should be selected based on the maximum work load and allowable moment.  
If the product is used outside of the operating specification, eccentric load applied to the guide will become excessive and have adverse effects such as creating play in the guide, reduced accuracy and reduced product life.
- ② **Do not exceed the speed limit of the specification.**  
Select a suitable actuator by the relationship of allowable work load and speed. Noise or reduction of accuracy may occur, if the actuator is operated in excess of its specification. This could lead to reduced accuracy and reduced product file.
- ③ **Do not use the product in applications where excessive external force or impact force is applied.**  
This can lead to premature failure of the product.
- ④ **Select a suitable actuator by the relationship of the work load and speed.**  
If the body is fixed at the end of the actuator (end mounting), excessive load will act on the actuator body, which may adversely affect the operation and life of the product.

## ■ Handling



### Caution

#### ① OUT output signal

##### 1) Positioning Operation

When the actuator moves to within a set range using parameter 【OUT output signal with】 , the output signal, INP, will be turned on.

Set to [0.50] or higher. It may cause malfunction.

#### ② When pushing operation, be sure to use in “pushing operation”.

**Do not hit the work piece in positioning operation or in the range of positioning operation.** It may lead to a malfunction.

#### ③ Keep the specifications driving speed range for pushing operation.

This may lead to damage and malfunction.

#### ④ Check the specification for the minimum speed of the actuator. Operation outside the specifications may cause malfunctions such as knocking.

#### ⑤ The actual speed of the product can be changed by the load.

When selecting a product, check the catalog for instructions regarding selection and specifications.

#### ⑥ Do not apply a load, impact or resistance in addition to a transferred load during return to origin.

Otherwise, the origin can be displaced since it is based on the detected motor torque.

#### ⑦ In pushing operation, set the product to a position of at least 2mm away from a work piece. (This position is referred to as a pushing start position.)

If the product is set to the same position as a work piece, the following alarm and unstable operation can occur.

##### a. "Posn failde" alarm

The product cannot reach a pushing start position due to the deviation of work pieces in width.

##### b. "Pushing ALM" alarm

The product is pushed back from a pushing start position after starting to push.

#### ⑧ Do not scratch or gouge the sliding parts of the piston rod, by striking or grasping them with other objects.

Piston rod is manufactured to precise tolerances, so that even a slight deformation may cause malfunction.

#### ⑨ Please connect the product such that the impact and load may not be added to the rod from the side when an external guide is used.

Use a freely moving connector (such as a floating joint).

#### ⑩ Please do not operate body itself by the piston rod fixing.

An excessive load joins the piston rod, and it causes defective operation and the longevity decrease.

- ⑪ **When an actuator is operated with one end fixed and the other free (ends tapped or flange type), a bending moment may act on the actuator due to vibration generated at the stroke end, which can damage the actuator. In such a case, install a mounting bracket to suppress the vibration of the actuator body or reduce the speed so that the actuator does not vibrate at the stroke end.**

Also, use a mounting bracket when moving the actuator body or when a long stroke actuator is mounted horizontally and fixed at one end.

- ⑫ **Avoid using the electric actuator in such a way that rotational torque would be applied to the piston rod.**

If rotational torque is applied, the non-rotating guide will become deformed, thus affecting the non-rotating accuracy. Refer to the table below for the approximate values of the allowable range of rotational torque.

Allowable rotational torque (N · m or less)	EQY16**	EQY25**	EQY32**
		0.8	1.1

To screw a bracket or a nut onto the threaded portion at the tip of the piston rod, make sure to retract the piston rod entirely, and place a wrench over the flat portion of the rod that protrudes. Tighten it by giving consideration to prevent the tightening torque from being applied to the non-rotating guide.



- ⑬ **Operate within the following ranges of the duty ratio when pushing operation.**

The duty ratio is a ratio at the time that can keep being pushed.

Model	Ambient temperature [°C]	Pushing force [%]	Duty ratio [%]	Continuous Pushing force time [mm]
EQY16	40 or less	25~45	100	-
EQY25	40 or less	25~50	100	-
EQY32	40 or less	30~70	100	-

- ⑭ **When installing the main unit, ensure that the cable can bend according to the minimum specified radius (48 mm minimum).**



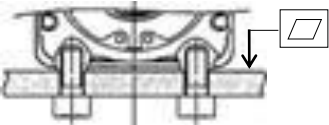
## ■ Mounting

### ⚠ Caution

⑮ Design the installation so that the temperature surrounding the actuator is 40°C or less.

② Keep the flatness of the mounting surface within the following ranges when mounting the actuator body and work piece.

Insufficient flatness of the work piece or the surface onto which the actuator body is to be mounted can cause increased sliding resistance, noise, life time reduction.

Model	Mounting point	Flatness
EQY*	Body/Bottom of the body 	0.1mm or less

③ Fix 'Socket' square width across flats in the piston rod point with the spanner etc. , prevent the piston rod from rotating, and tighten the screw tightening when work piece or tool, etc. are installed properly by the torque value within the Maximum tightening torque.

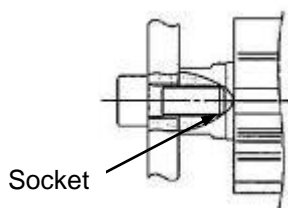
It causes the abnormal reaction of an auto switch, the space of an internal guide, and an increase of the sliding resistance, etc.

④ When mounting the product, use screws of adequate length and tighten them to the correct torque.

Tightening the screws with a higher torque than the maximum may cause malfunction, whilst tightening with a lower torque can cause the displacement of the mounting position or in extreme conditions detaching of the work piece.

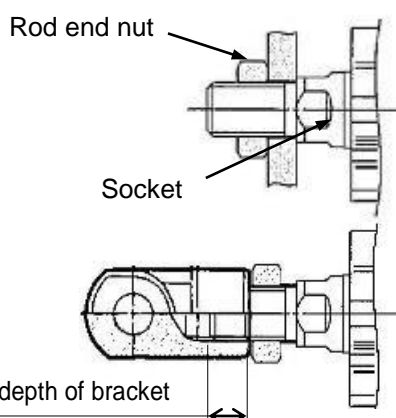
### <How to install the EQY Series>

#### Work fixed/ Rod end female thread



Model	Bolt used	Tightening [N·m]	Max. screw depth [mm]	Tip socket opposite side[mm]
EQY16	M5x0.8	3±10%	10	14
EQY25	M8x1.25	12.5±10%	13	17
EQY32	M8x1.25	12.5±10%	13	22

#### Work fixed/ Rod end male thread

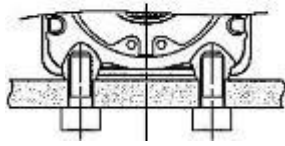


Model	Bolt used	Tightening [N·m]	Max. screw depth [mm]	Tip socket opposite side[mm]
EQY16	M8x1.25	12.5±10%	12	14
EQY25	M14x1.5	50±10%	20.5	17

Model	Rod end Nut		Tip fitting thread depth [mm]
	Opposite[mm]	Length[mm]	
EQY16	13	5	5 or more
EQY25	16 - 22	8	8 or more
EQY32	22	8	8 or more

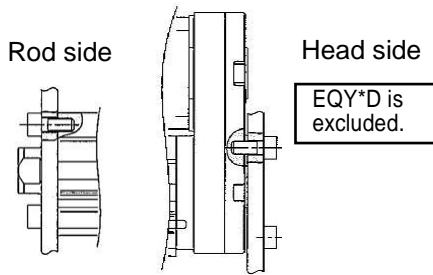
\*Rod end nuts are accessories.

Mounting / Body bottom tapped style



Model	Bolt used	Tightening torque [N·m]	Max. screw depth [mm]
EQY16	M4x0.7	1.5±10%	5.5
EQY25	M5x0.8	3.0±10%	6.5
EQY32	M6x1.0	5.2±10%	8.5

Mounting/Rod side, Head side tapped style



Model	Bolt used	Tightening torque [N·m]	Max. screw depth [mm]
EQY16	M4x0.7	1.5±10%	7
EQY25	M5x0.8	3.0±10%	7
EQY32	M6x1.0	5.2±10%	7

**⚠ Caution**

If the mounting surface of the controller is distorted or not flat, excessive force may be applied to the housing, etc. causing malfunction.  
Mount this product on a plane surface.

■ **Maintenance**

**⚠ Caution**

- ① **Cut the power supply during maintenance and replacement of the product.**

**【 Maintenance frequency 】**

Perform maintenance according to the table below. Please contact SMC if there are any problems.

Frequency	Appearance check	Belt check
Inspect daily before operating	○	-
Inspection every six months / 1000km / 5million cycle*	○	○

\*Either of inspection early time is selected.

**【 Items for visual appearance check 】**

1. Loose set screws, abnormal dirt.
2. Check of flaw and cable joint
3. Vibration, noise

**【Grease application】**

If grease lubrication performance is reduced due to operating environment or operating conditions, please re-apply grease.

**1. Grease application to the piston rod**

Fully extend the piston rod by performing a JOG operation and apply grease to the base of the piston rod.

\*For lubrication, use lithium grease No. 2.

When ordering the grease from SMC, please order a grease pack: GR-S-□.

Grease package No.
GR-S-010 (10g)
GR-S-020 (20g)

L=10 to 15mm  
(per 100mm of piston stroke)  
e.g.) For 200mm stroke, L = 20 to 30mm  
\* Apply grease evenly over the piston rod base.

After applying grease, operate the piston rod 2 to 3 times to spread the grease evenly over the full stroke of the piston rod.

**2. Grease application to the inside of the body and to the ball screw**

(For strokes of 200 mm or more)

Move the piston rod to the extended end by JOG operation, etc., and remove the oil filler cap. Insert the tip of the spray grease into the grease inlet and spray the inside of the body with grease. After applying grease, attach the cap.

Make it reciprocate 2 to 3 times by JOG operation, etc. to distribute the grease evenly.

\* For lubrication, use lithium soap grease No. 2.

**[ Items for belt check ]**

Check the belt regularly as shown in “maintenance frequency”.

Stop operation immediately and contact SMC when the belt appears to be like the photographs shown below.

**a. Tooth shape canvas is worn out**

Canvas fiber becomes fuzzy. Rubber is removed and the fiber becomes white in color. Lines of fibers become unclear.



Teth become fuzzy

**b. Peeling off or wearing of the side of the belt**

Belt corner becomes round and frayed threads sticks out.



Bottom portion of belt gear worn-out (frayed thread exposed )

**c. Belt partially cut**

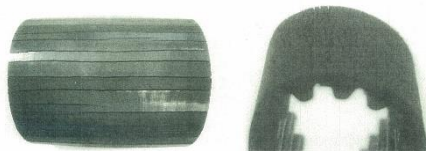
Belt is partially cut. Foreign matter caught in teeth other than cut part causes flaw.

**d. Vertical line of belt teeth**

Flaw which is made when the belt runs on the flange.

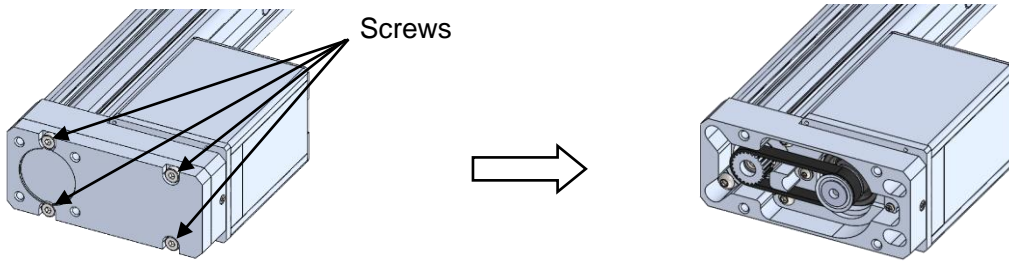
**e. Rubber back of the belt is softened and sticky**

**f. Crack on the back of the belt**

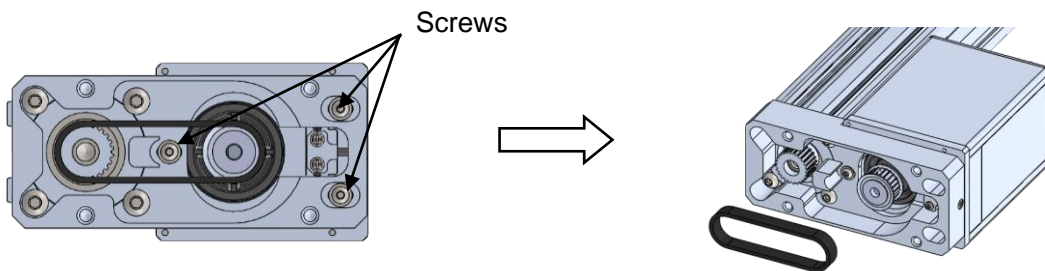


## ■ Replacement of belt

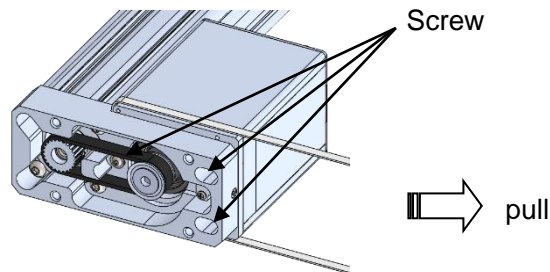
- ① After screws are removed, the "Pulley plate" is removed.



- ② The motor fixing screws are loosened (To extent in which the slide can be done), the "Bearing support" is removed, and the "Belt" is removed.



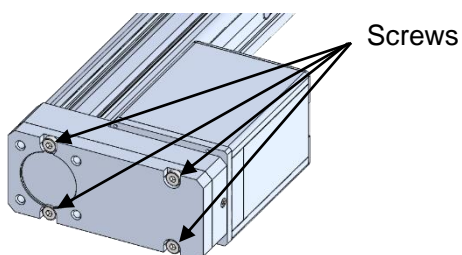
- ③ After the "Belt" is installed, and the bearing support is obtained, the root of the "Motor" is pulled using a string or a long banding band. With the tensile force adjusted, tighten the screws which fix the actuator to the motor. (Refer to the table below)



Model	Belt Part number	Pull tension [N]
EQY16	LE-D-2-7	9.8
EQY25	LE-D-1-3	19.6
EQY32	LE-D-19-4	49.0

Model	Screw size	Tightening torque [Nm]
EQY16	M3	0.63±10%
EQY25		
EQY32	M4	1.5±10%

- ④ "Pulley plate" installation. (Refer to the table below)



Model	Screw size	Tightening torque [Nm]
EQY16	M3	0.63±10%
EQY25	M4	1.5±10%
EQY32	M6	5.2±10%

## Specific precautions for Battery-less absolute encoder

### ⚠ Warning

① **Do not use in an environment where a strong magnetic fields are present.**

A magnetic sensor is used in the encoder.

Therefore, if the actuator motor is used in a strong magnetic field environment, malfunction or failure may occur.

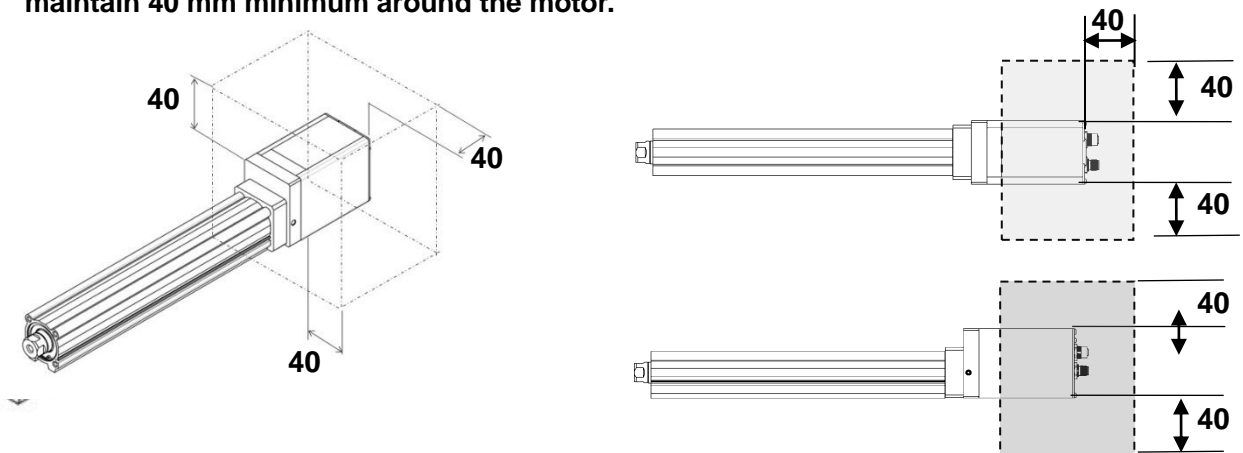
The major failure is described below.

- Reduction of transporting ability (pushing force, speed)
- Damage to the actuator due to collision to the workpiece by positional displacement occurred.

Do not expose the actuator motor to a magnetic field with a magnetic flux density of 13 mT or more.

(Example 1)

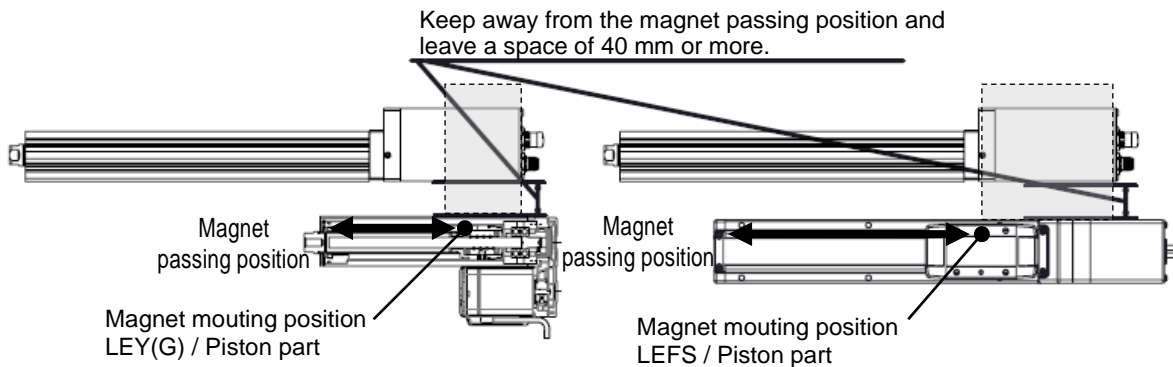
**When installing an air cylinder with an auto switch (ex. CDQ2 series) side by side, maintain 40 mm minimum around the motor.**



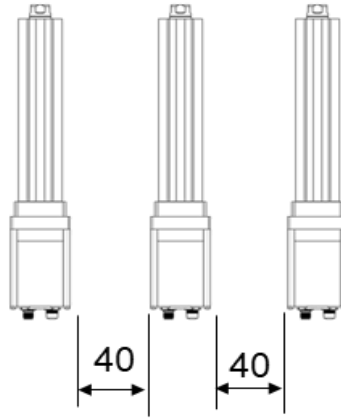
Air cylinder installation with an auto switch is forbidden in the shaded area.

Example 2)

When installing electric actuator LEY(G) or LEF, EQF, EQY series with an auto switch side by side, leave a gap of 40 mm or more with respect to the position where the magnet passes.



The motors of the electric actuator can be installed close to each other.



**⚠ Caution**

**① Supply power when the actuator is stationary.**

The electric actuator acquires the absolute position data from the absolute encoder when power is applied.

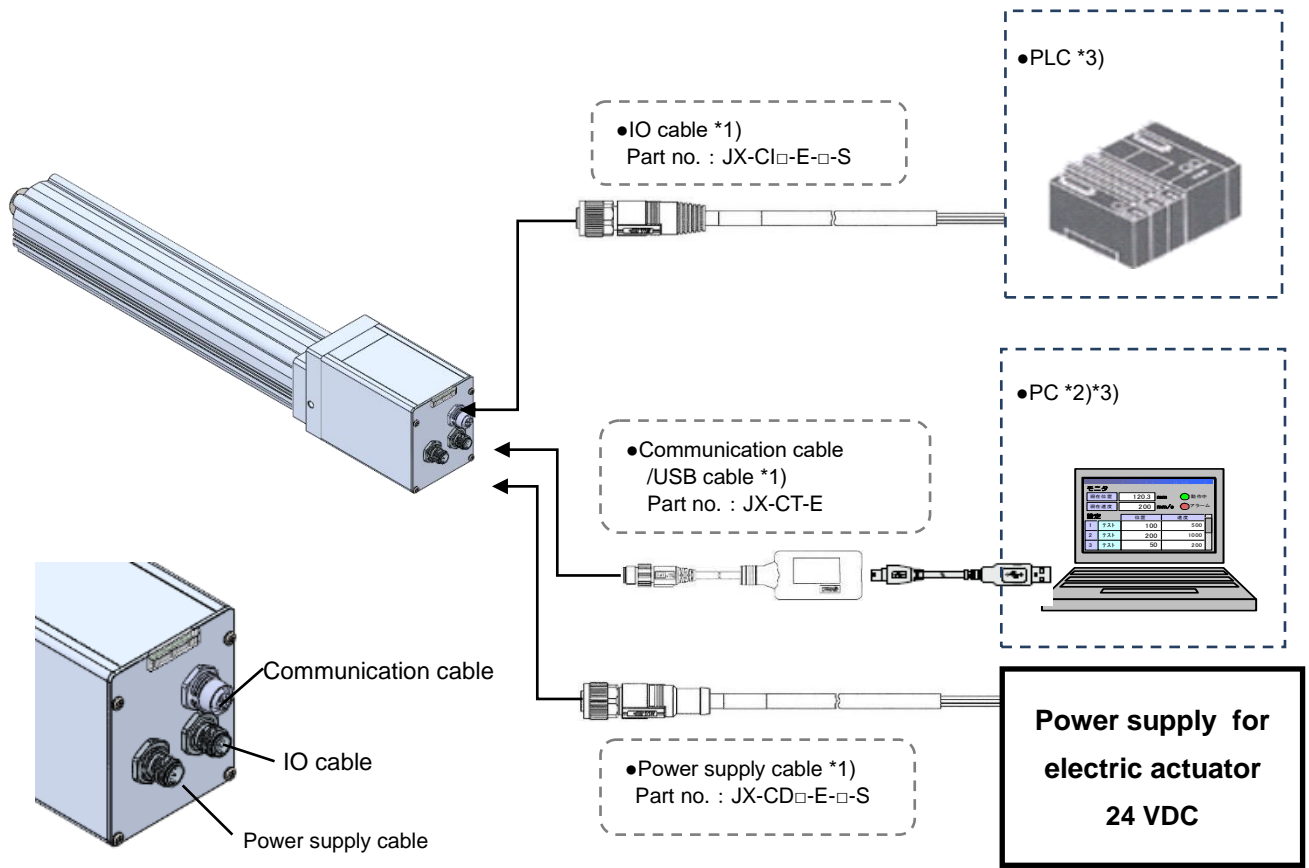
Therefore, if the power is applied to the electric actuator when the actuator is moving with an external force, the controller fails to acquire the absolute position data, which generates an alarm.



# 1 Outline of Product

## 1.1 System Construction Example

An example of a system configuration using the electric actuator is shown below.



\*1 Optional item.

\*2 Latest version of the configuration software must be used.

Please download it from the SMC website. <https://www.smcworld.com/>

\*3 PLC and PC are prepared by the user.

## 1.2 Features

Features of the electric actuator.

- Electric actuator control

Positioning operation and operation at a specific speed and force of the actuator are possible by controlling the Step motor (24 VDC servo).

- Specified force operation

Control the pushing force or the pressing force of the electric actuator.

- Alarm detection function

Abnormal conditions are automatically detected. Alarms are output via CC-Link communication.

The alarm history can be stored in the controller memory.

- Possible to select single solenoid, double solenoid, and closed center modes

Three control modes are available the single solenoid, double solenoid, and closed center and a valve control similar to a pneumatic air cylinder can be specified by selecting the mode.

- It is possible to perform the positioning operation to both ends or intermediate point and pushing operation to the end

Control the electric actuator according to the operation data specified by the input of parallel I/O.

It is possible to set up the operation data using setup software.

The positioning to both ends or the pushing operation can be set using single solenoid and double solenoid modes.

- OUT output function

The OUT output turns ON when the position of the electric actuator is within the range of the "OUT signal output width" parameter of the target position.

- Data input method

It is possible to perform parameter setup, status monitoring, trial run and alarm reset via the serial communication with a PC installed with the actuator setting software.

- Applicable for the Battery-Less Absolute Encoder

When using the electric actuator compatible with battery-less absolute encoder, detection of the absolute position enables the encoder to detect the actuator position when power is supplied, so operation is available with no return to origin operation.

### **Caution**

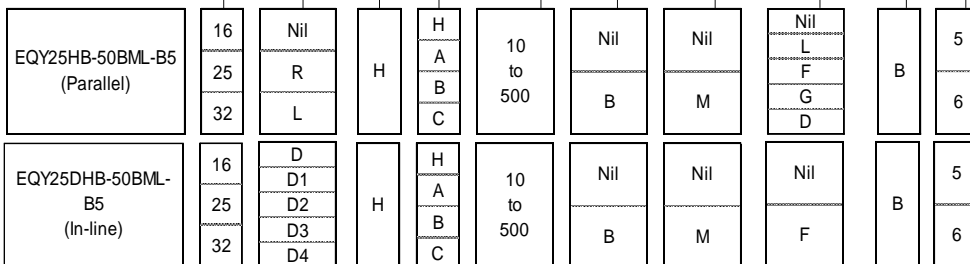
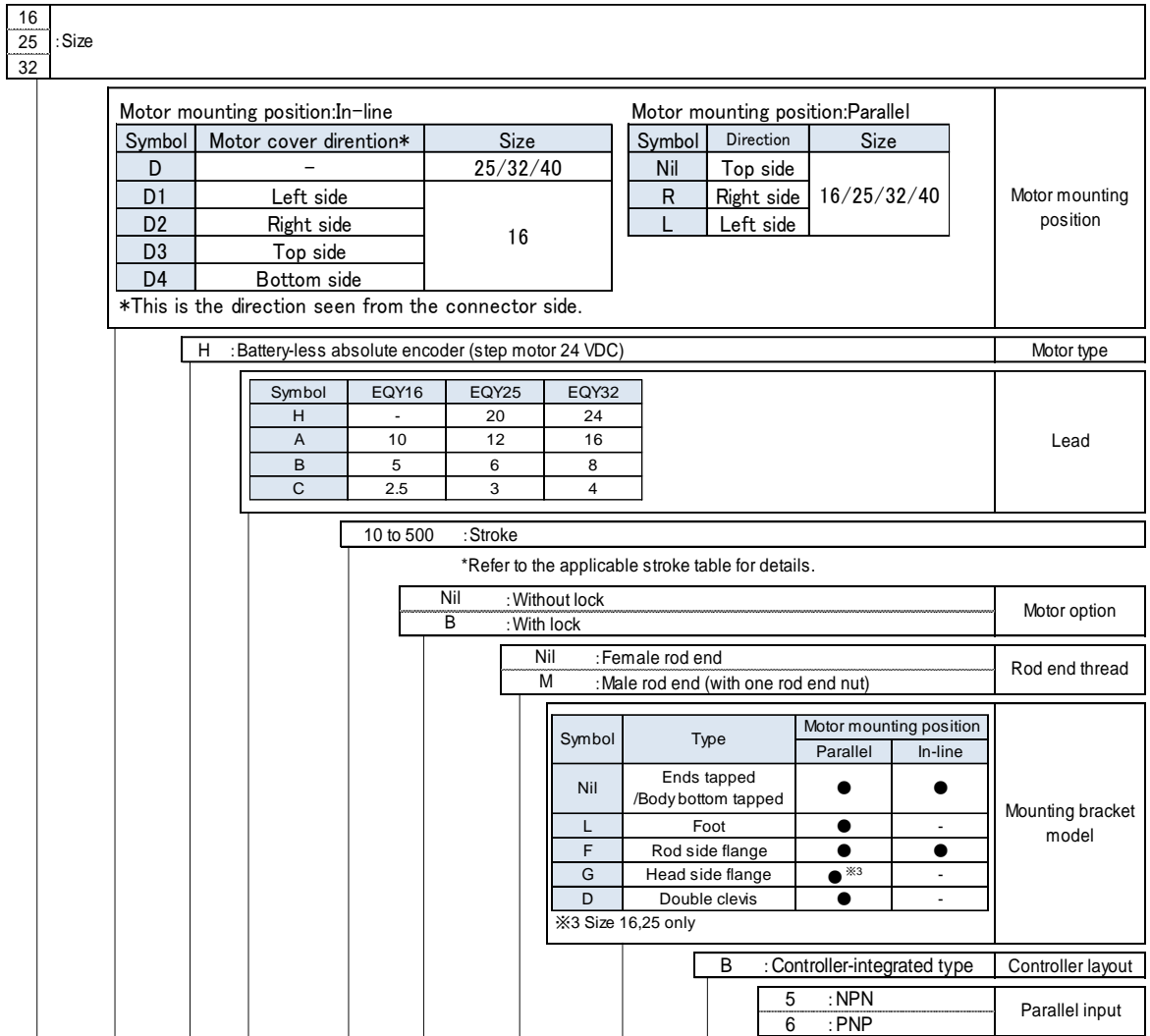
When the device is set up or failure occurs, please refer to the operation manual of software as well as this operation manual.

Keep this operation manual accessible for reference when necessary.

# 1.3 How to Order

How to order is shown below.

E Q Y 25 D H B - 50       - B 5



### Applicable stroke table

Size	Stroke [mm]											Manufacturable stroke range
	30	50	100	150	200	250	300	350	400	450	500	
16	●	●	●	●	●	●	●	-	-	-	-	10 to 300
25	●	●		●	●	●	●	●	●	-	-	15 to 400
32	●	●	●	●	●	●	●	●	●	●	●	20 to 500

## 1.4 Specifications

### Battery-less absolute encoder type (Step motor 24 VDC)

Model		EQY16			EQY25				EQY32					
Actuator specification	Stroke [mm]	30 to 300			30 to 400				30 to 500					
	Work load [kg] Note.1)	Horizontal	17	25	40	8	26	40	70	30	50	90	100	
		Vertical	3	6	10	2	8	16	30	3	13	26	46	
	Pushing force[N] Note2),3),4)		19 to 38	36 to 74	69 to 141	31 to 61	63 to 122	126 to 238	232 to 452	50 to 118	80 to 189	156 to 370	296 to 707	
	Speed[mm/s]	Stroke Range	to 300	15 to 700	8 to 350	4 to 175	30 to 900	18 to 700	9 to 450	5 to 225	30 to 900	24 to 800	12 to 400	6 to 200
			350 to 400	-	-	-	30 to 900	18 to 600	9 to 300	5 to 150	30 to 900	24 to 640	12 to 320	6 to 160
			400 to 500	-	-	-	-	-	-	-	30 to 900	24 to 640	12 to 320	6 to 160
	Max. acceleration/deceleration speed [mm/s <sup>2</sup> ]	Horizontal	10000											
		Vertical	5000											
	Pushing speed [mm/s <sup>2</sup> ] Note5)		25			35				30				
	Positioning repeatability [mm]		±0.02											
	Lost motion[mm] Note6)		0.1 or less											
	Lead [mm]		20	12	6	20	12	6	3	24	16	8	4	
	Impact/Vibration resistance[m/s <sup>2</sup> ] Note7)		50/20											
Actuation type		Ball screw+Belt (EQY□H), Ball screw(EQY□DH)												
Guide type		Sliding bush (Piston rod)												
Operating frequency [°C]		5 to 40												
Operating humidity [%RH]		90 or less (Non-excitation-operated type)												
Electric specification	Motor size	□42						□56						
	Motor type	Battery-less Absolute (Step motor 24VDC)												
	Encoder	Battery-less Absolute												
	Power supply voltage [V]	24VDC±10%												
	Power [W] Note8),9)	Max. 86			Max. 86				Max. 104					
Lock unit specifications	Type Note10)	Non-excitation-operated type												
	Holding force [N]	20	39	78	47	78	157	294	75	108	216	421		
	Power consumption [W] Note9)	2.9			5				5					
	Power supply voltage [V]	24VDC±10%												

Note1) Horizontal : Use an external guide (external guide friction coefficient: 0.1 or less).

The maximum value of the work load for the positioning operation.

The actual transported mass and transport speed will vary depending on the external guide conditions.

Also, please check the speed/acceleration and duty ratio depending on the payload in the "Speed vs. payload graph" in the catalog.

Vertical : Use an external guide (external guide friction coefficient: 0.1 or less) when the rod is directed upward or radial load is applied to the rod.

The maximum value of the work load for the positioning operation.

The actual transported mass and transport speed will vary depending on the external guide conditions.

Also, please check the speed/acceleration and duty ratio depending on the payload in the "Speed vs. payload graph" in the catalog.

Set the acceleration/deceleration to horizontal: 10000 [mm/s<sup>2</sup>] or less, vertical: 5000 [mm/s<sup>2</sup>] or less.

Note 2) Pushing force accuracy is ±20% (F.S.).

Note 3) The setting range for the "Pushing force" is from 25% to 50%(EQY25□H) and 30% to 70%(EQY32□H).

The pushing force setting range varies depending on the duty ratio and pushing speed. Please check the "Thrust Conversion Graph" in the catalog.

Note 4) Speed and thrust may vary depending on cable length, load, installation conditions, etc.

If the cable length exceeds 5m, the speed/thrust will decrease by up to 10% for every 5m. (For 15m: Max. 20% reduction)

Note 5) "Pushing speed" is the allowable speed for the pushing operation.

When transporting and pushing a workpiece, operate the actuator with the "vertical load capacity" or less.

Note 6) This is a reference value for correcting errors in reciprocating motion.

Note 7) Impact resistance: In a drop impact test, no malfunction occurred in the axial direction and perpendicular direction of the feed screw. (value at the initial stage)

Vibration resistance: 45 to 2000 Hz 1 sweep, no malfunction in the axial direction and perpendicular direction of the feed screw. (value at the initial stage)

Note 8) Power indicates the maximum power during operation including the controller.

Use this when selecting the power supply capacity.

Note 9) For an actuator with lock, add the power consumption for the lock.

Note 10) Only applies to actuators supplied with a lock.

Weight

Series	EQY16 (Motor mounting position: parallel type)							
Stroke[mm]	30	50	100	150	200	250	300	Additional mass with lock
Product weight[kg]	0.62	0.64	0.77	0.93	1.10	1.22	1.33	0.19

Series	EQY25 (Motor mounting position: parallel type)									
Stroke[mm]	30	50	100	150	200	250	300	350	400	Additional mass with lock
Product weight[kg]	1.74	1.81	1.98	2.24	2.42	2.59	2.77	2.94	3.12	0.31

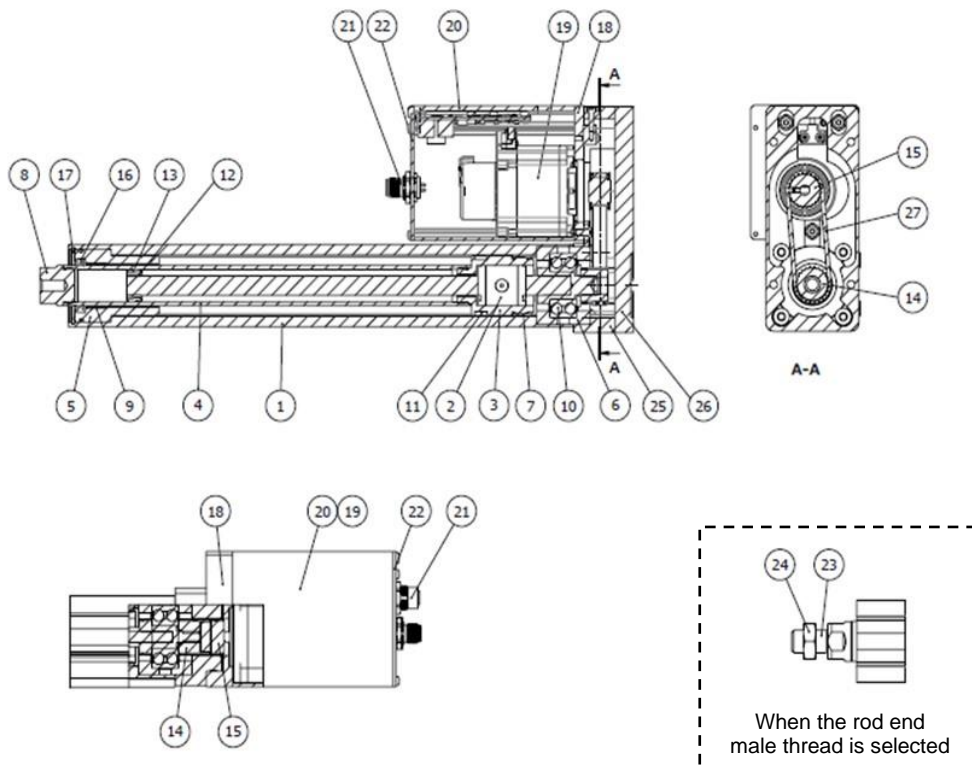
Series	EQY32 (Motor mounting position: parallel type)											
Stroke[mm]	30	50	100	150	200	250	300	350	400	450	500	Additional mass with lock
Product weight[kg]	2.74	2.85	3.14	3.42	3.82	4.11	4.39	4.68	4.97	5.25	5.54	0.58

Series	EQY16 (Motor mounting position: In-line)							
Stroke[mm]	30	50	100	150	200	250	300	Additional mass with lock
Product weight[kg]	0.60	0.63	0.76	0.92	1.09	1.20	1.31	0.19

Series	EQY25 (Motor mounting position: In-line)									
Stroke[mm]	30	50	100	150	200	250	300	350	400	Additional mass with lock
Product weight[kg]	1.60	1.67	1.84	2.10	2.28	2.45	2.63	2.80	2.98	0.31

Series	EQY32 (Motor mounting position: In-line)											
Stroke[mm]	30	50	100	150	200	250	300	350	400	450	500	Additional mass with lock
Product weight[kg]	2.55	2.66	2.95	3.23	3.63	3.92	4.20	4.49	4.78	5.06	5.35	0.58

## 1.5 Construction



### Component Parts

No.	Description	Material	Note
1	Body	Aluminum alloy	Anodized
2	Ball screw assembly	-	
3	Piston	Aluminum alloy	
4	Piston rod	Stainless steel	Hard chrome plating
5	Rod cover	Aluminum alloy	
6	Bearing holder	Aluminum alloy	
7	Rotation stopper	Synthetic resins	
8	Socket (Female thread)	Free cutting carbon steels	Nickel plating
9	Bushing	Bearing alloy	
10	Bearing	-	
11	Magnet	-	
12	Wear ring holder	Stainless steel	For 101 strokes or more

No.	Description	Material	Note
13	Wear ring	Synthetic resins	For 101 strokes or more
14	Pulley/Hub	Aluminum alloy	
15	Pulley /Hub	Aluminum alloy	
16	Retaining ring	NBR	
17	Retaining ring	Steel for spring	
18	Motor Adapter	Aluminum alloy	Anodized
19	Motor	-	
20	Motor cover	Aluminum alloy	Anodized
21	Connector	-	
22	End cover	Aluminum alloy	Anodized
23	Socket(Male thread)	Free cutting	Nickel plating
24	Hexagon nut	-	For rod end male threads

### Components Parts (Top/Right/Left side parallel only)

No.	Description	Part	Remarks
25	Return box	Aluminum die-cast	Coating
26	Return plate	Aluminum die-cast	Coating
27	Belt	-	

### Replacement Parts (Top/Right/Left side parallel only)/Belt

No.	Size	Order No.
27	16	LE-D-2-7
	25	LE-D-19-3
	32	LE-D-19-4

### Mounting Bracket Part No.

Size	Foot	Flange	Double clevis
16	LEY-L016	LEY-F016	LEY-D016
25	EQY-L025	EQY-F025	EQY-D025
32	EQY-L032	EQY-F032	EQY-D032

### Replacement Parts /Grease pack

Applied portion	Order No.
Piston rod	GR-S-010(10G)
	GR-S-020(20G)

\*When ordering foot bracket, order 2 pieces per actuator.

\*Refer to "1-6 Accesories" for belonging parts of each bracket.

## 1.6 Accessories

### Rod end thread

Rod end thread	Accessories	
	Part name	QTY
Male	Rod end male thread	1

### Mounting bracket

Mounting	Motor mounting position		Accessories	
	Parallel	In-line	Part name	QTY
Foot type	●	-	Foot bracket	2
			Mounting bolt	4
Rod side Flange type	●	●	Flange	1
			Mounting bolt	4
Head side Flange type	●	-	Flange	1
			Mounting bolt	4
Double clevis type	●	-	Clevis	1
			Clevis pin	1
			Retaining ring	2
			Mounting bolt	4

### ■Optional parts (sold separately)

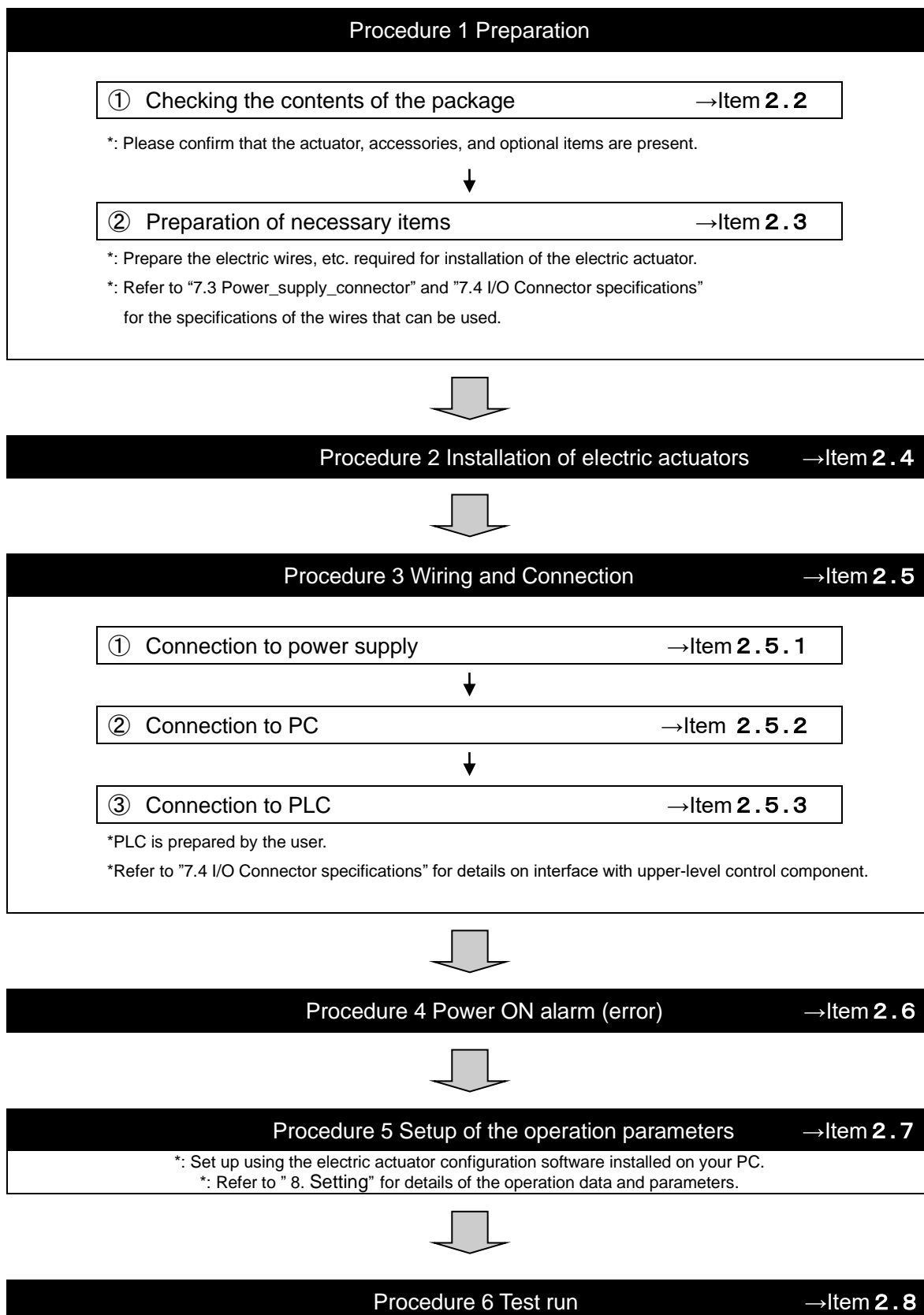
- Power supply cable
- Parallel I/O cable
- Communication cable
- USB cable
- Setup software

Refer to **9 Optional parts (sold separately)** for details of optional parts.

## 2 Installation and Initial Setting

### 2.1 Flow procedure from installation to initial setting

Be sure to check the procedure below before use.

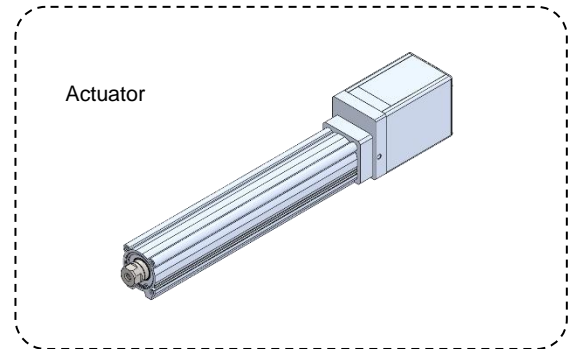




## 2.2 Check the contents of the package

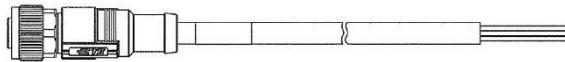
After unpacking everything, check the description on the label to identify the electric actuator and the number of accessories. If any parts are missing or damaged, please contact your distributor.

Product Name and Number	Quantity
Electric actuator (EQY□)	1 pcs.

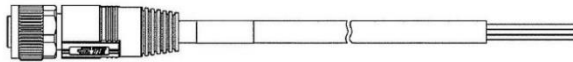


### 【Optional parts】 (sold separately)

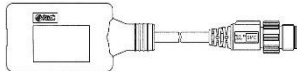
- Power supply cable



- I/O cable



- Setup communication cable



- USB cable



- Setup software

Please download the setup software from the SMC website. <https://www.smcworld.com/>

## 2.3 Preparation of necessary supplies

Please prepare the following items for installation and wiring.

- Wiring cables
- M4 screws
- Cable with crimping terminals
- Switch (24 VDC, contact capacity of 0.5 A or more) : For lock release

Please provide the following equipment to run the system.

- 24 VDC power supply
- PC
- PLC

## 2.4 Installation of electric actuators

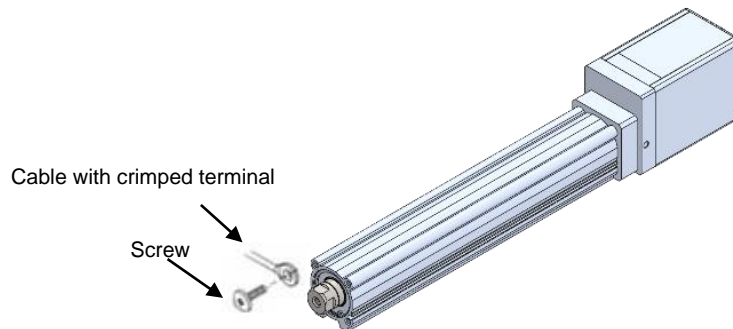
Install the electric actuator at the installation location using the following method.

### (1) Mounting

Refer to "Precautions for product specific" for "Electric actuator/Individual precautions" information on screws and tightening torques to be used for mounting workpieces and tools and for mounting the actuator.

### (2) Connection to ground

Be sure to ground the mounting hole of the body.

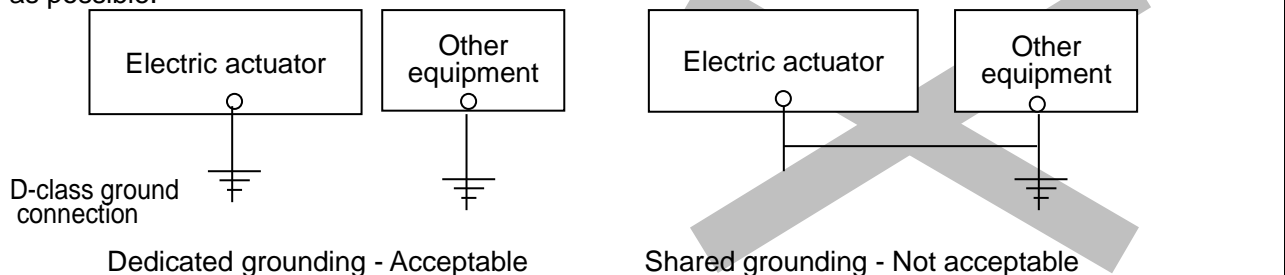


#### ⚠ Caution

The M4 screw, cable with crimped terminal and toothed washer must be prepared by the user. The actuator must be connected to Ground to reduce noise. If further noise resistance is required, consider measures such as grounding the 0 V (signal ground). When grounding the 0 V, avoid flowing noise from the ground to the 0 V.

#### ⚠ Caution

The earth should be a dedicated earth connection. Use a D-class ground connection (ground with a resistance of less than  $100\Omega$ ). The cross sectional area of the grounding cable shall be  $2\text{mm}^2$  minimum. The Grounding point should be as near as possible to the actuator. Keep the grounding cable as short as possible.

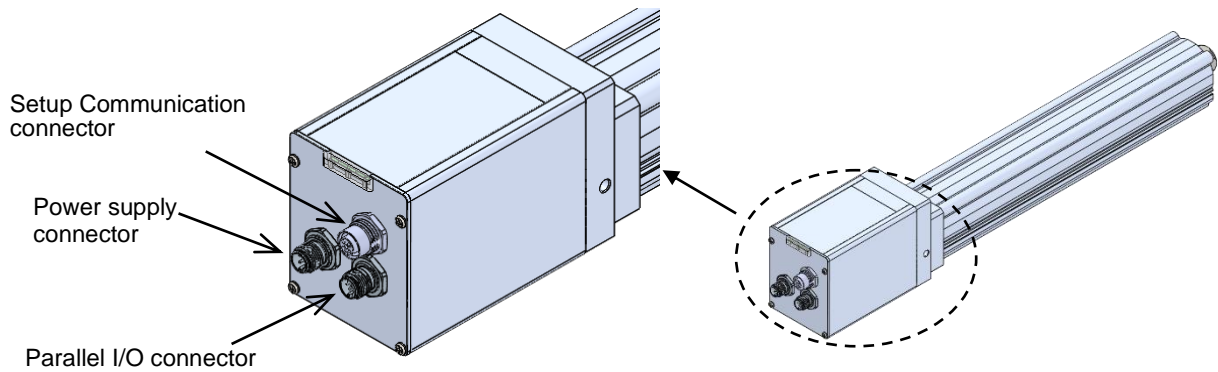


### (3) Precautions for electric actuator compatible with battery-less absolute encoder installation

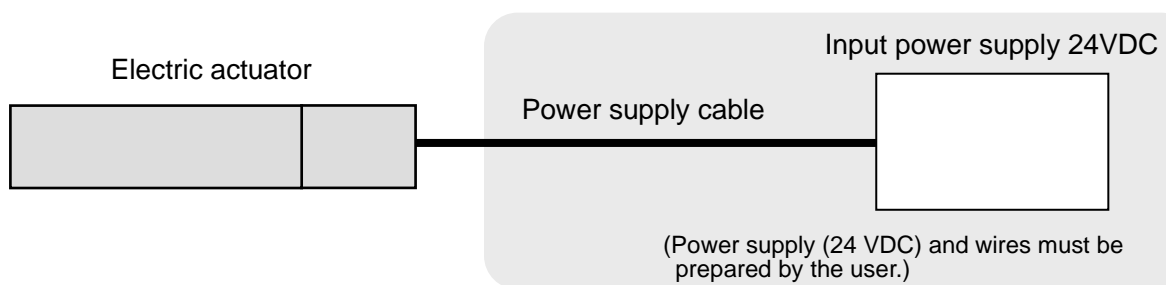
Please refer to Precautions for product specific of Individual precautions for battery-less absolute encoder.

## 2.5 Wiring and Connection

Connect the cable to the connector part of the electric actuator.



### 2.5.1 Connection to input power supply



#### **⚠ Caution**

Do not use an inrush current control type of power supply.

#### (1) Wiring of the power supply cable

Connect the power supply cable to the 24VDC power supply according to instructions 1) ,2) and 3) and then insert it into the actuator connector.

#### **⚠ Caution**

Arrange wiring so that the conductors of each wire do not contact other lines.

#### 1) Wiring of power supply (C24V, M24V, 0V)

Connect the positive side (+) of the actuator input power supply 24VDC to the C24V and M24V electric wire of the power supply cable and connect the negative (-) to the 0V electric wire.

#### **⚠ Caution**

Do not use a power supply with "inrush-current control" for the power supply.

## 2) Wiring of the stop switch (EMG)

When applying 24 V to M24V electric wire, the product starts operating. When 24 V is turned off, the Servo OFF activates and the product stops operating.

A stop switch must be installed by the user to stop the actuator in abnormal situations for this M24V wire.

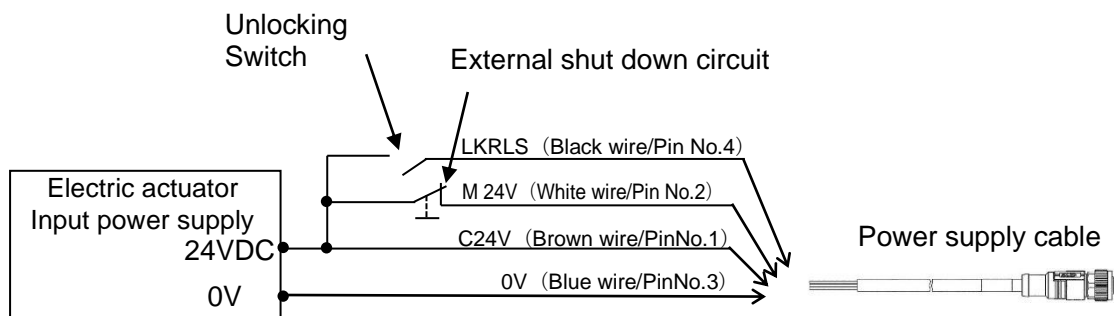
Refer to ■ **Wiring of shutdown circuit** for wiring.

## 3) Wiring of the lock release (LK RLS)

Install an unlocking switch for adjustment or recovery during an emergency of the locking actuator.

\* The switch (24 VDC, contact capacity: 0.5 A or more) needs to be prepared by the user.

One terminal of the lock release switch should be connected to the 24 VDC power supply and the other should be connected to the LK RLS electric wire. When this is switched on, the lock will be released.



### ⚠ Caution

It is not necessary to connect the LK RLS terminal when the actuator does not have a locking mechanism.

The LK RLS wire terminal is only used for adjustment and emergency return. It must not be energized during normal operation.

After wiring the power supply plug, connect it to the power connector of the actuator.

## (2) Wiring of a shutdown circuit

Design the circuit so that M24V is turned off when the stop switch and ALARM are turned off.

(see P.35 Fig.1-1 and Fig.1-2 for circuit example)

Operation resumes when the stop is released. Please release the stop after fully confirming safety.

The operation when the stop is released differs depending on the mode.

Please check the following.

### Operation when stop is released.

- For single solenoid mode

Operation starts according to the state of the IN1 signal.

When IN1 is OFF: Moves to the home end. When IN1 is ON: Moves to the opposite end.

- For double solenoid mode

Executes IN0 or IN1 that was input immediately before releasing the stop.

If IN0 and IN1 are not changed while M24V is OFF, the operation before the stop switch (or ALARM) was turned off will resume.

If the operation is not restarted immediately after the stop is released, turn off the C24V as well as the M24V. (see P.36 Fig.2-1 and Fig.2-2 for circuit example)

If the C24V is turn off when stopped, the operation will start when IN0 or IN1 turns ON after the stop is released.

- For closed center mode

Operation according to the state of the IN0 and IN1 signals.

If you do not restart the operation after releasing the stop, release the stop while both IN0 and IN1 are OFF.

IN0	IN1	Operation when stop is released
ON	OFF	Move to origin end
OFF	ON	Move to opposite end
ON	ON	Move to intermediate position
OFF	OFF	Stop

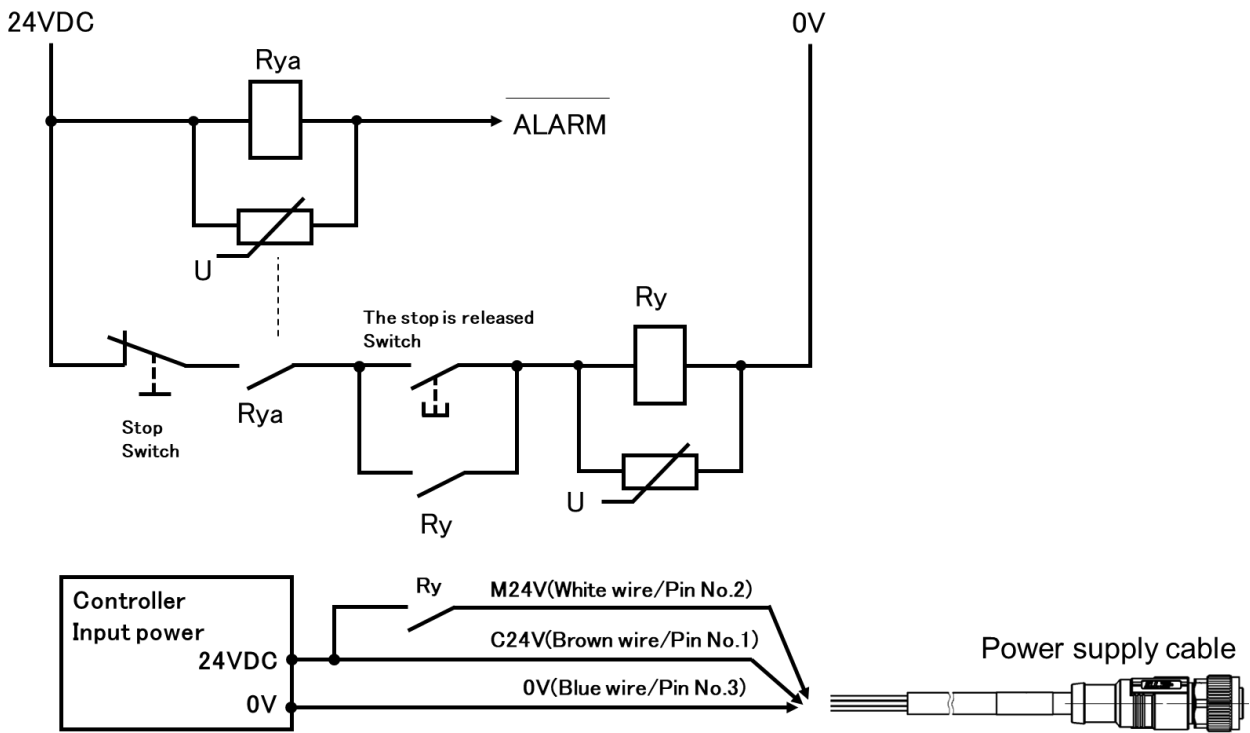
### Caution

When a shutdown is input, the actuator stops with maximum deceleration, then the motor is turned OFF.

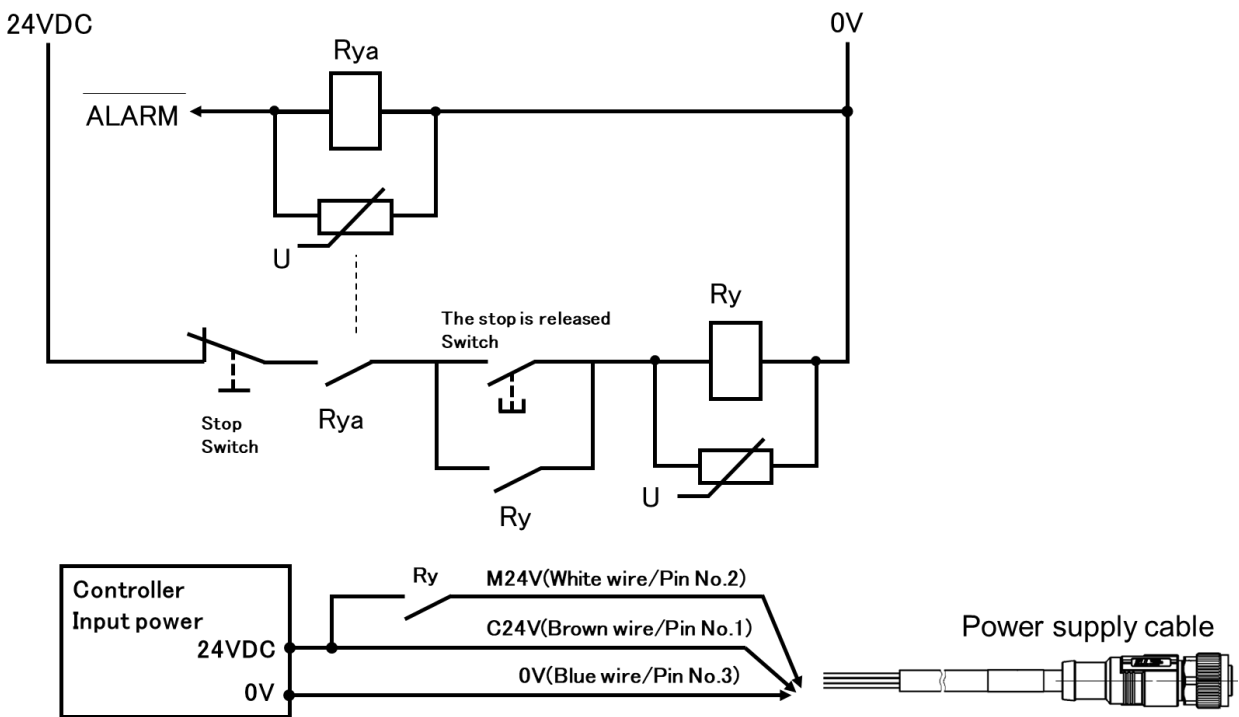
### Warning

If an electric actuator with lock is used vertically, a delay in response of the Lock may occur when turning off the motor power supply (M24V), and the moving part of the actuator may drop due to the weight of the actuator itself.

**Fig.1-1 Circuit example(for NPN type)**

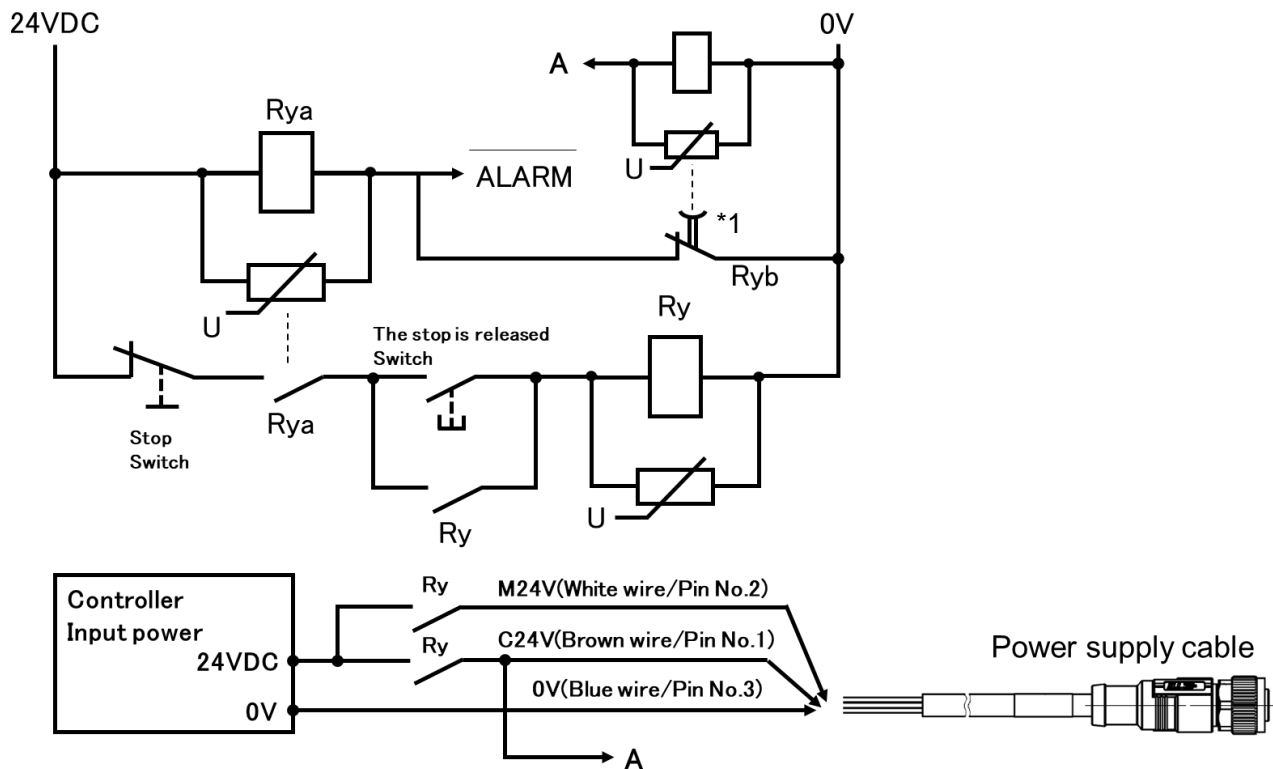


**Fig.1-2 Circuit example(for PNP type)**



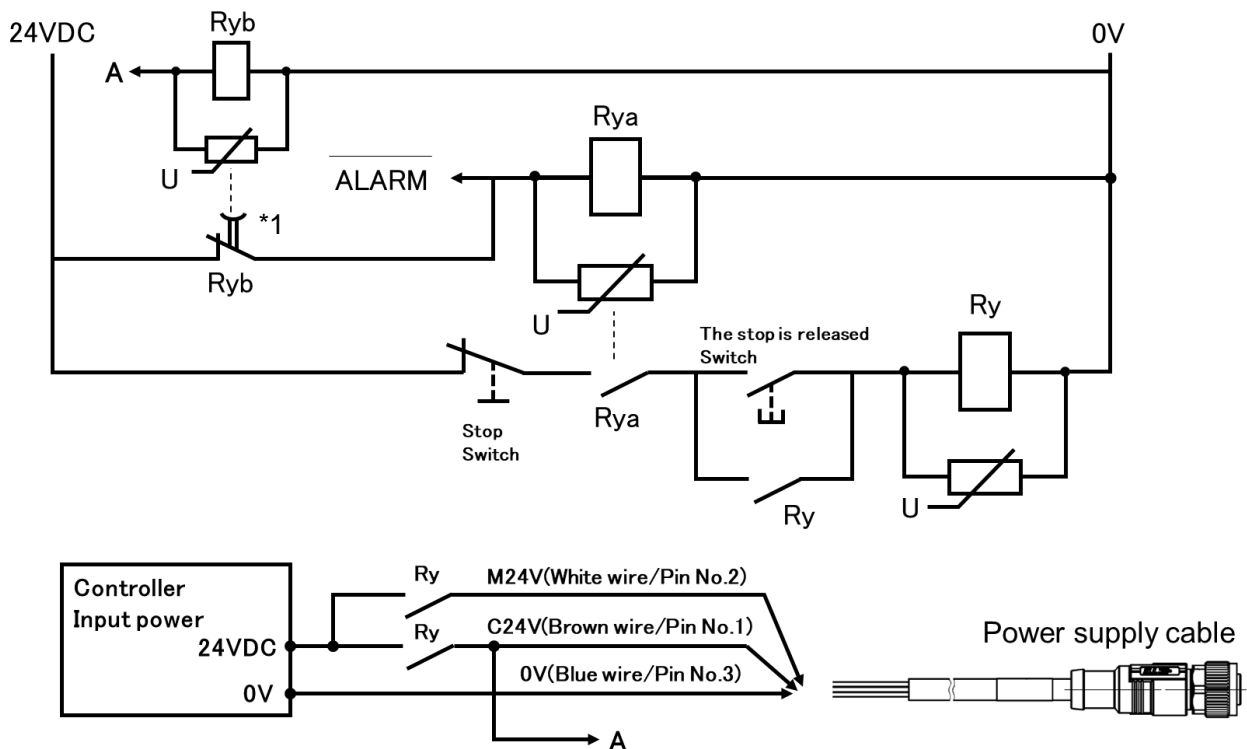
**Fig. 2-1 Circuit example(For NPN type)**

**Example where operation is not restarted when double solenoid mode stop is released.**



**Fig. 2-2 Circuit example(for PNP type)**

**Example where operation is not restarted when double solenoid mode stop is released)**



Set the timer setting value to 0.5 seconds or more.  
 Also, add the delay time such as the rise time of the 24V power supply specification to the timer setting value.  
 e.g. If the delay time of the 24V power supply is 1.0 seconds, the timer setting value will be: 1.5 (=0.5+1.0) seconds or more.

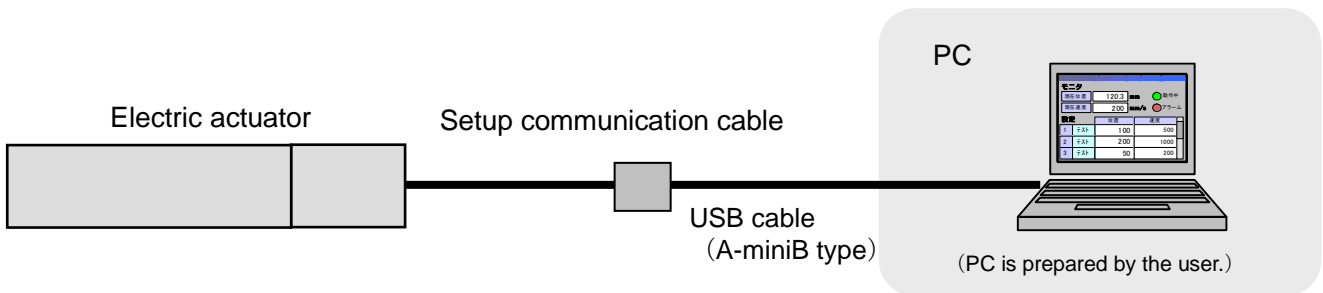


## 2.5.2 Connection to PC

---

Connect the setup communication cable between the communication connector of the electric actuator and the PC.

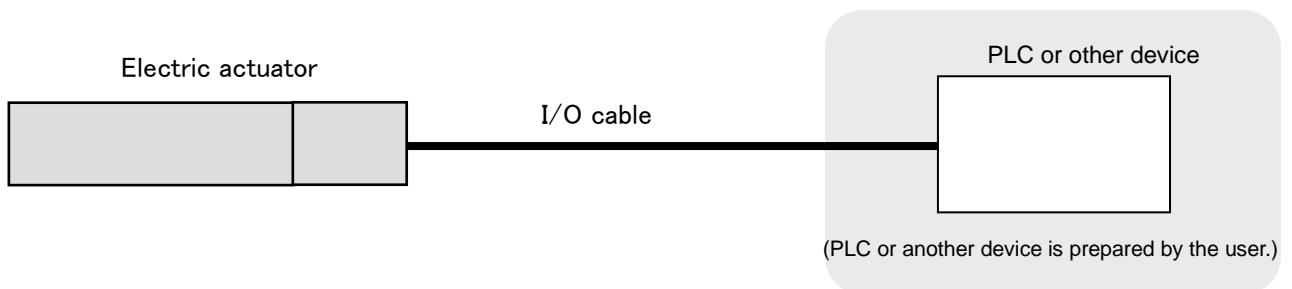
- Setup communication cable part number (with A-miniB type USB cable): JX-CT-E



## 2.5.3 Connection to PLC

---

Connect the I/O cable between the I/O connector of the electric actuator and the PLC, etc.



Refer to "[7.4 I/O Connector specifications](#)" for details on parallel input/output and parallel input/output signals.

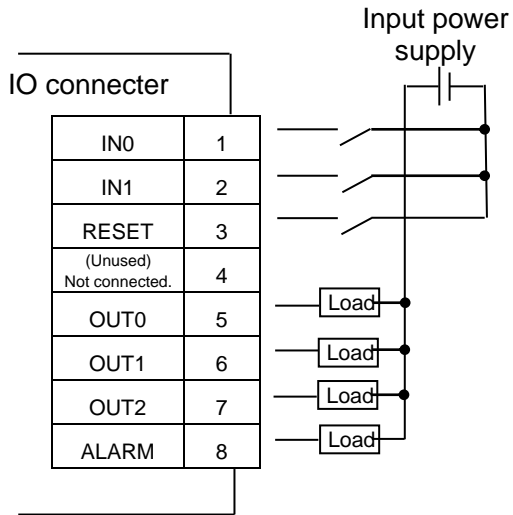
### ■ I/O Wiring Example

Use the I/O cable (JX-CI□-E-□-S) for connecting a PLC to the I/O connector.

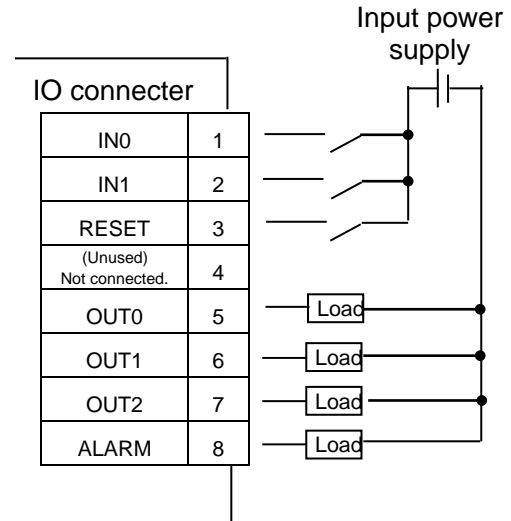
Wiring depends on the parallel input/output type of the actuator (NPN or PNP).

Perform wiring referring to the wiring diagram below.

●NPN type



●PNP type

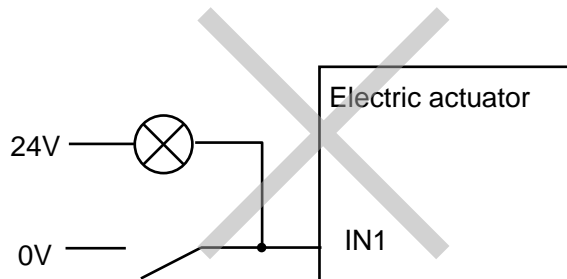


**⚠ Caution**

The parallel input/output of this electric actuator is of non-isolated specification.

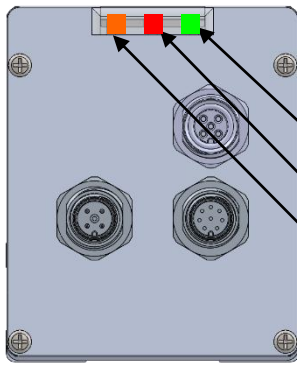
- The power supply for parallel input/output should be common to the power supply input to the control power supply C24V.
- Do not apply 5 V or more to the NPN type input terminal (IN0, IN1, RESET).  
It may damage the input circuit.

Example) Do not connect the LED to the input terminal as shown in the diagram below.



## 2.6 Power ON alarm (error)

Check that there is no problem with the wiring while referring to [2.5 Wiring and Connection](#) and supply 24 VDC power supply between C24V - 0V (power supply input for control) and between M24V - 0V (power supply input for power line) of the power supply cable.



Electric actuator

LED	LED status	Status
PWR (Green)	ON	Normal
ALM (Red)	OFF	No alarms
OVL(Orange)	OFF	No Overload warning

If the [PWR] LED on the electric actuator is green, it is in normal condition.

If the [ALM] LED on the electric actuator is red, an alarm has been generated.

\*If the [PWR] LED on the electric actuator is off, the voltage between M24V - 0V is low or 0 VDC.

\*If the [OVL] LED on the electric actuator is orange, the electric actuator operation may be in an overload condition.

### ⚠ Caution

When an alarm is generated, connect the setup software to the setup communication connector of the electric actuator, check the alarm details, and solve the cause while referring to [5.Alarm detection](#).

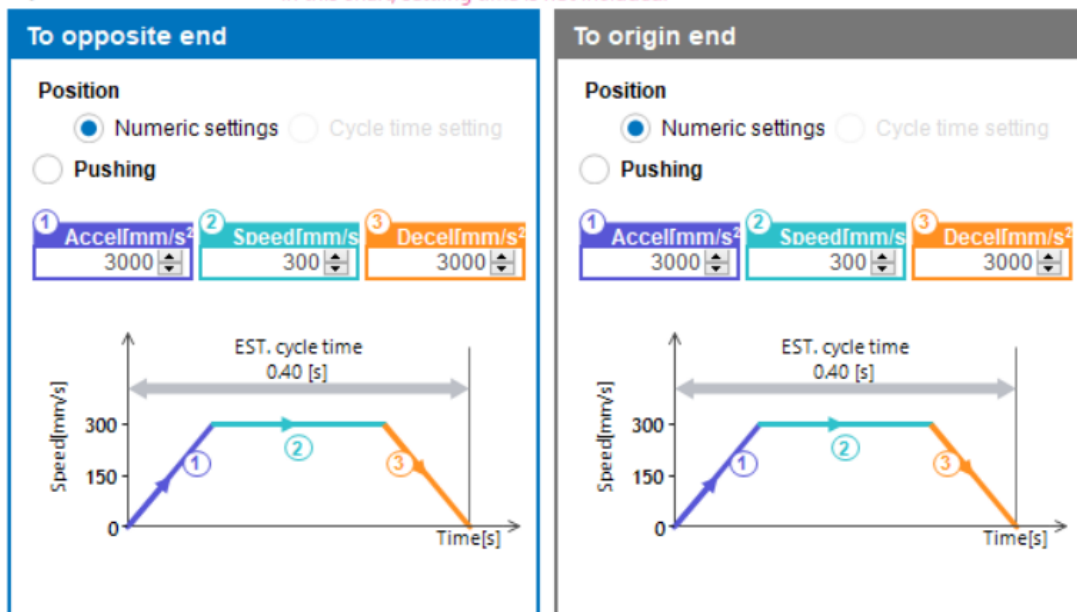
Refer to the operation manual of the setup software for the alarm checking method.

## 2.7 Setup of the operation parameters

Set the operating data and parameters using the setting software.

- Setting Software \*Refer to the operation manual of the setting software for the setup method.

Operation condition \* In this chart, settling time is not included.



## ■ Settings and Data Entry

Setup of the operation data is required using the setup software to move the electric actuator to the specified position. The data entered using the setup software is stored in the memory of the electric actuator.

Three types of control modes that provide control similar to a pneumatic cylinder are available with this electric actuator, which could be used according to the purpose and preference.

Select from the three modes described below using the setup software.

The setting at the time of shipment is set to "**Closed center mode**" as default.

- Single solenoid mode

The electric actuator can be controlled in a similar way to controlling a single solenoid valve.

The actuator moves to the opposite end when the IN1 input signal is turned ON and moves to the origin end when turned OFF.

The Positioning operation to both ends or the pushing operation is possible.



### Warning

In the single solenoid mode, note that the operation will immediately start after the actuator input power is supplied when the stop position is at a position other than the origin end or the opposite end.

- Double solenoid mode

The electric actuator can be controlled in a similar way to controlling a double solenoid valve.

The actuator moves to the origin end when the IN0 input signal is turned ON and moves to the opposite end when the IN1 input signal is turned ON.

The Positioning operation to both ends or the pushing operation is possible.

- Closed center mode

The electric actuator can be controlled in a similar way to controlling a closed center valve.

The actuator moves to the origin end when IN0 input signal is turned ON (IN1 input signal is turned OFF).

The actuator moves to the opposite end when the IN1 input signal is turned ON (IN0 input signal is turned OFF).

The actuator moves to the intermediate position when both IN0 input signal and IN1 input signal are turned ON.

The positioning operation to both ends and the intermediate position as well as the pushing operation to both ends are possible.

Refer to 8 Setting for details of the operation data and parameters.

## 2.8 Test run

Test run to ensure that the electric actuator is operating normally in the system.

Refer to the operation manual of the setting software for how to perform a trial run.

## 3 Operation

### 3.1 Operation flow

The startup procedure varies depending on the power-on situation.

#### Procedure1 Startup

- When turning on the power supply normally after shipment from SMC
- When supplying power again after resetting the alarm Group E or after changing the parameter of "return to origin direction"



#### Procedure 2 Operation Instructions

- |                          |            |
|--------------------------|------------|
| ① Positioning operation  | →Item3.3.2 |
| ② Pushing operation      | →Item3.3.3 |
| ③ Reset                  | →Item3.3.4 |
| ④ Interrupting operation | →Item4.5   |

## 3.2 Procedure for power set up

### 3.2.1 Procedure for power start up

The following is a Startup procedure for the battery-less absolute encoder for every occasion that occurs when the power is applied

- (1) **When turning on the power supply normally after shipment from SMC**
- (2) **When supplying power again after resetting the alarm Group E due to power supply shutdown or after changing the parameter of "return to origin direction"**  
\*Return to origin is required. Return to origin is performed as the first operation command after turning on the power supply.



Warning

The operation for the return to the origin is performed after resetting the Group E alarm and when the operation command is given as the first IN0, IN1 after changing the "return to origin direction" parameter followed by the content of the operation command.

### 3.2.2 Power Supply Startup

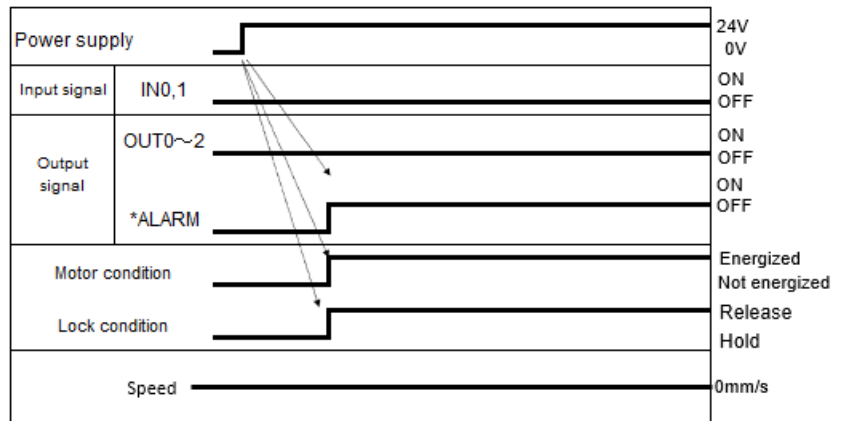
- (1) **When turning on the power supply after shipment from SMC**

The operation preparation is complete if "\*\*ALARM" is turned ON (no alarm) when the power supply is turned on again.

#### - Procedure -

1. Turn on the power supply
- ↓
2. \*It is possible to provide operation command by IN0 and IN1 when the ALARM output is turned ON and servo is turned ON.

#### -Timing chart-



\*\*\*Alarm" and "\*\*ESTOP" are displayed in negative logic.

\*\*\*Alarm" and "\*\*ESTOP" are displayed in negative logic.

### ! Caution

When the slider is not at the origin end position in the single solenoid mode, it moves to the origin end by turning OFF the IN1 input.

**(2) When supplying power again after resetting the alarm Group E or after changing the parameter of "return to origin direction"**

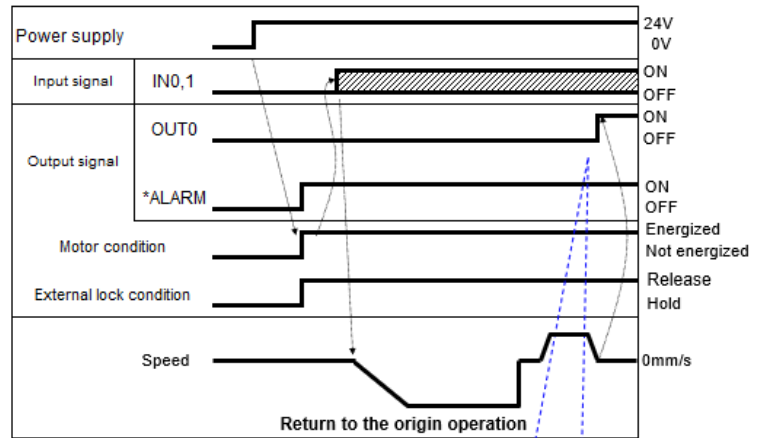
Return to the origin operation is required when the alarm Group E is generated and the alarm is reset due to power supply shutdown or when the "return to origin direction" parameter is changed.

**- Procedure -**

1. Turn on the power supply  
↓
2. \*Turn the ALARM output ON and the servo ON.  
\*The lock will be released for the actuator with a lock.  
↓
3. Turn the IN0 input or IN1 input ON  
(Performs the return to the origin operation.)  
\*Return to the origin operation is performed as the first operation command after resetting the alarm Group E or after the "return to origin direction" parameter is changed.  
↓
4. OUT0 output is ON  
Return to origin completed.

It is possible to provide an operation command by IN0 and IN1.

**-Timing chart-**



\*The \*\*ALARM" is displayed in negative logic.

ON when return to the origin is completed.

**⚠ Warning**

The operation for the return to origin is performed after resetting the Group E alarm and when the operation command is given as the first IN0, IN1 after changing the "return to origin direction" parameter followed by the content of the operation command.

### 3.3 Operation Instructions

#### 3.3.1 Outline of operation commands

Operation commands can be provided by the operation data pre-registered in the electric actuator using parallel I/O signals.

The operation procedure differs according to the control mode.

There are two operation patterns within the operation data.

- Positioning operation
- Pushing operation

There are three control modes.

- Single solenoid mode
- Double solenoid mode
- Closed center mode

The operation procedures are described below.

#### 3.3.2 Positioning operation

##### (1) Positioning operation using single solenoid mode

###### - Procedure (Single solenoid mode) -

1. Specify a command operation using the operation data by turning IN1 input ON/OFF.  
⇒ Load the specified operation data.

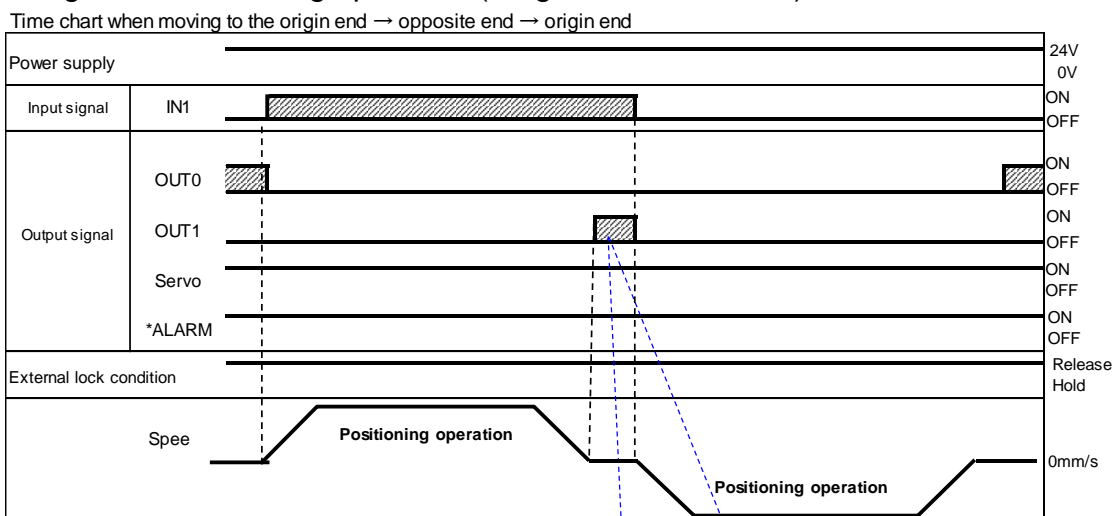
IN1: ON → Command to move to the opposite end IN1: OFF → Command to move to the origin end
---

2. Start the positioning operation.

3. When reaching the target position, OUT \*output signal corresponding to the operation data turns ON. The positioning operation is completed.

OUT0 output: ON → Completes the move to the origin end OUT1 output: ON → Completes the move to the opposite end
--

###### - Timing chart Positioning operation (Single solenoid mode) -



\*The "\*ALARM" is displayed in negative logic.

\*\*Power ON" in the timing chart shows the power supply is turned ON.

\*\*Servo ON" shows that power is supplied to the motor and it is operable.

\* If the IN1 input signal is OFF when the power supply is turned on again, the operation to the "Origin end" will be operated immediately, so please check the safety before proceeding.



## (2) Positioning operation using double solenoid mode

### - Procedure (Double solenoid mode) -

1. Specify a command operation using the operation data by turning IN0 or IN1 inputs ON.

⇒ Load the specified operation data

IN0 input: ON (IN1: OFF) → Command to move to the origin end
IN1 input: ON (IN0: OFF) → Command to move to the opposite end

↓

2. Start the positioning operation.

Turn IN0 or IN1 input OFF

↓

3. When reaching the target position, OUT0 output and OUT1 output signal turn ON corresponding to the operation data.

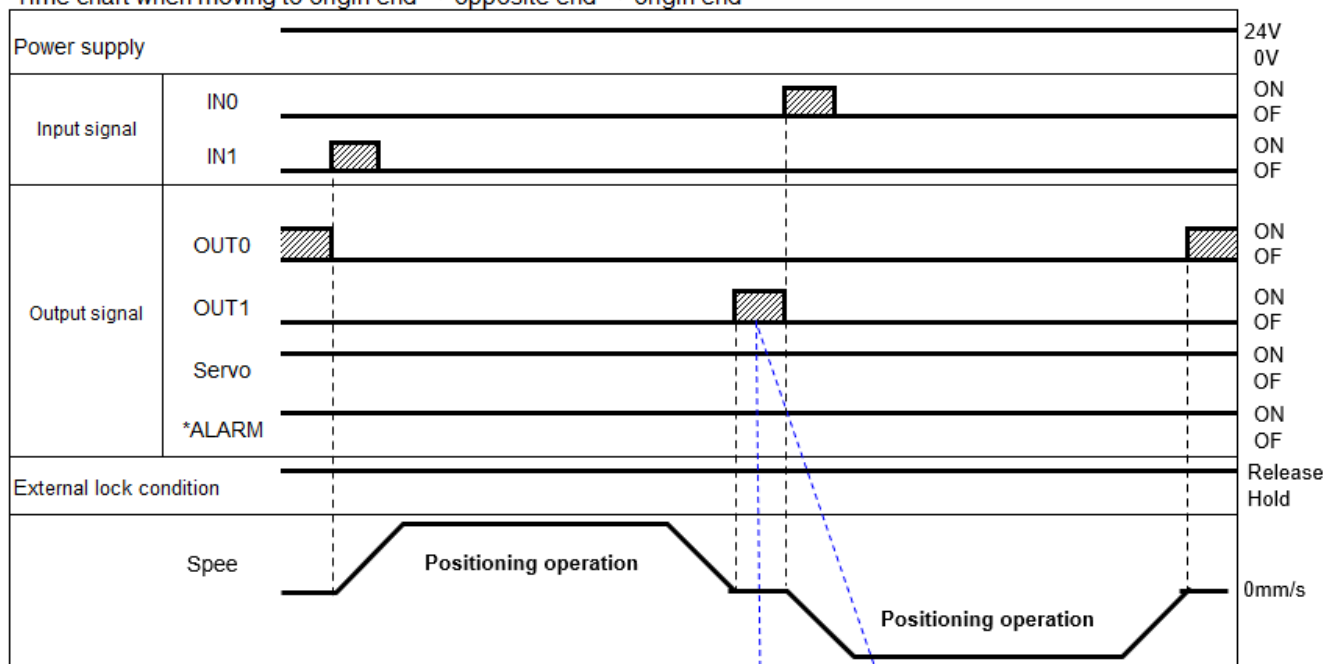
The positioning operation is completed.

OUT0 output: ON → Completes the move to the origin end
OUT1 output: ON → Completes the move to the opposite end

\*In double solenoid mode, simultaneous ON or simultaneous OFF of IN0 and IN1 is invalid. The operation condition or the stopped condition continues accordingly.

### - Timing chart Positioning operation (Double solenoid mode) -

Time chart when moving to origin end → opposite end → origin end



\*The "\*"ALARM" is displayed in negative logic.

\*\*"Power ON" in the timing chart shows the power supply is turned ON.

\*\*"Servo ON" shows that power is supplied to the motor and it is operable.

### (3) Positioning operation using closed center mode

#### - Procedure (Closed center mode) -

1. Specify a command operation using the operation data by turning IN0 and IN1 inputs ON/OFF.

⇒ Load the specified operation data.

( IN0 input: ON (IN1: OFF) → Command to move to the origin end  
 IN1 input: ON(IN0: OFF) → Command to move to the opposite end  
 IN0, IN1 input: ON → Command to move to the intermediate point )



2. Start the positioning operation.



3. When reaching the target position, the OUT0, OUT1, and OUT2 output signals corresponding to the operation data turn ON.

The positioning operation is completed.

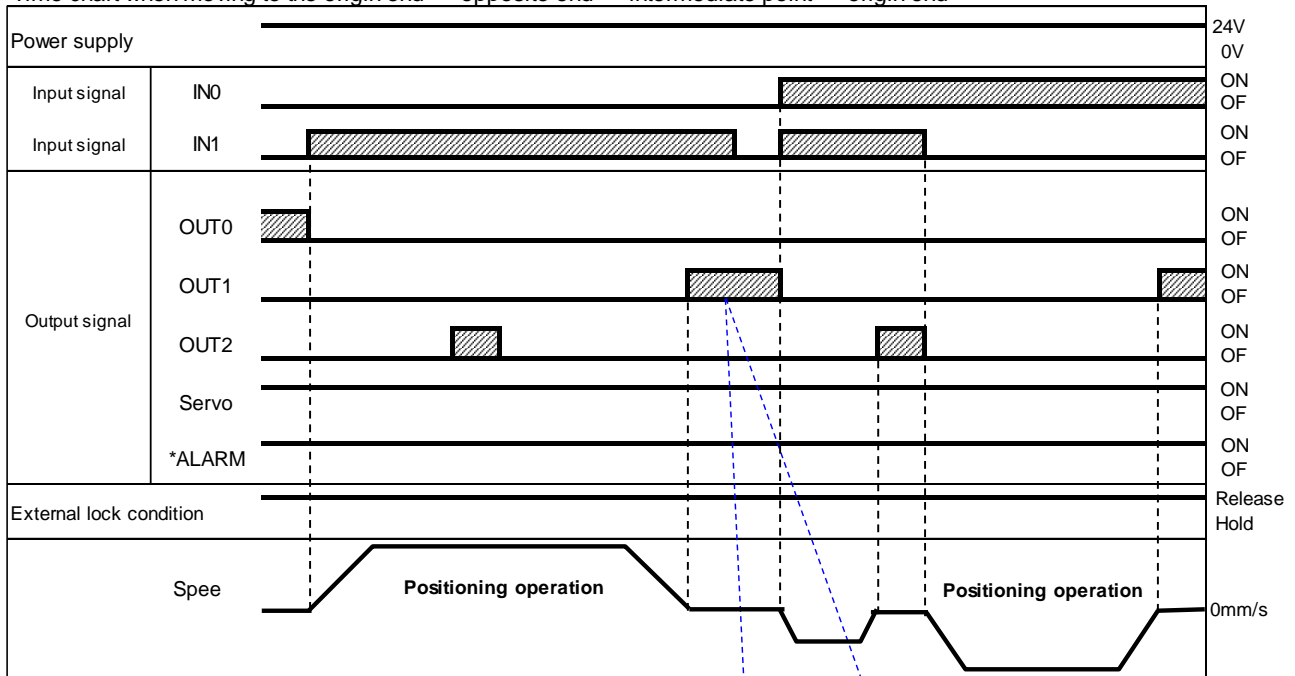
( OUT0 output: ON → Completes the move to the origin end  
 OUT1 output: ON → Completes the move to the opposite end  
 OUT2 output: ON → Completes the move to the intermediate point )

\*When IN0 and IN1 are turned OFF simultaneously in the closed center mode, the deceleration and stop operation performed when in operation condition or the stopped condition will be maintained when stopped.

\*Pushing operation cannot be performed at the intermediate point.

#### - Timing chart Positioning operation (Closed center mode) -

Time chart when moving to the origin end → opposite end → intermediate point → origin end



\*The "\*ALARM" is displayed in negative logic.

\*\*"Power ON" in the timing chart shows the power supply is turned ON.

\*\*"Servo ON" shows that power is supplied to the motor and it is operable.

\*The operation stops when the signal of IN0 or IN1 is turned OFF.

### 3.3.3 Pushing operation

#### (1) Pushing operation using single solenoid mode

##### - Procedure (Single solenoid mode) -

1. Specify a command operation using the operation data by turning IN1 input ON/OFF.  
⇒ Load the specified operation data.

{ IN1: ON → Command to move to the opposite end  
 IN1: OFF → Command to move to the origin end }

↓

2. Starts the positioning operation until the start position for the pushing operation.

↓

3. Starts pushing operation at low speed when it reaches the start position for the pushing operation.

↓

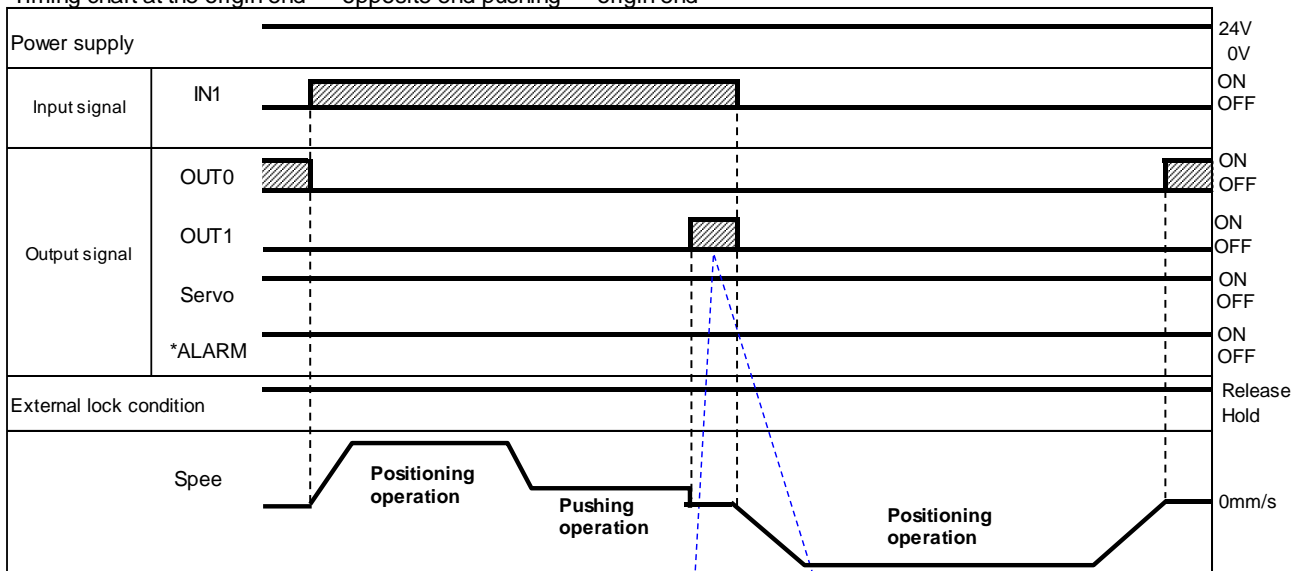
4. When the pushing operation is started and the set pushing force is reached, the OUT0 and OUT1 output signals corresponding to the commanded operation data turn ON to complete the pushing operation.

(Pushing force set by the operation data is generated.)

{ OUT0 output: ON → Completes pushing to the origin end  
 OUT1 output: ON → Completes pushing to the opposite end }

##### - Timing chart Pushing operation (Single solenoid mode) -

Timing chart at the origin end → opposite end pushing → origin end



\*The "\*"ALARM" is displayed in negative logic.

\*\*"Power ON" in the timing chart shows the power supply is turned ON.

\*\*"Servo ON" shows that power is supplied to the motor and it is operable.

\* If the IN1 input signal is OFF when the power supply is turned on again, the operation to the "Origin end" will be operated immediately, so please check the safety before proceeding.

## (2) Pushing operation using double solenoid mode

### - Procedure (Double solenoid mode) -

1. Specify a command operation using the operation data by turning IN0 and IN1 inputs ON/OFF.

⇒ Load the specified operation data.

{ IN0: ON → Command to move to the opposite end  
 IN1: OFF → Command to move to the origin end }

↓

2. Starts the positioning operation until the start position for the pushing operation.

↓

3. Starts pushing operation at low speed when it reaches the start position for the pushing operation.

↓

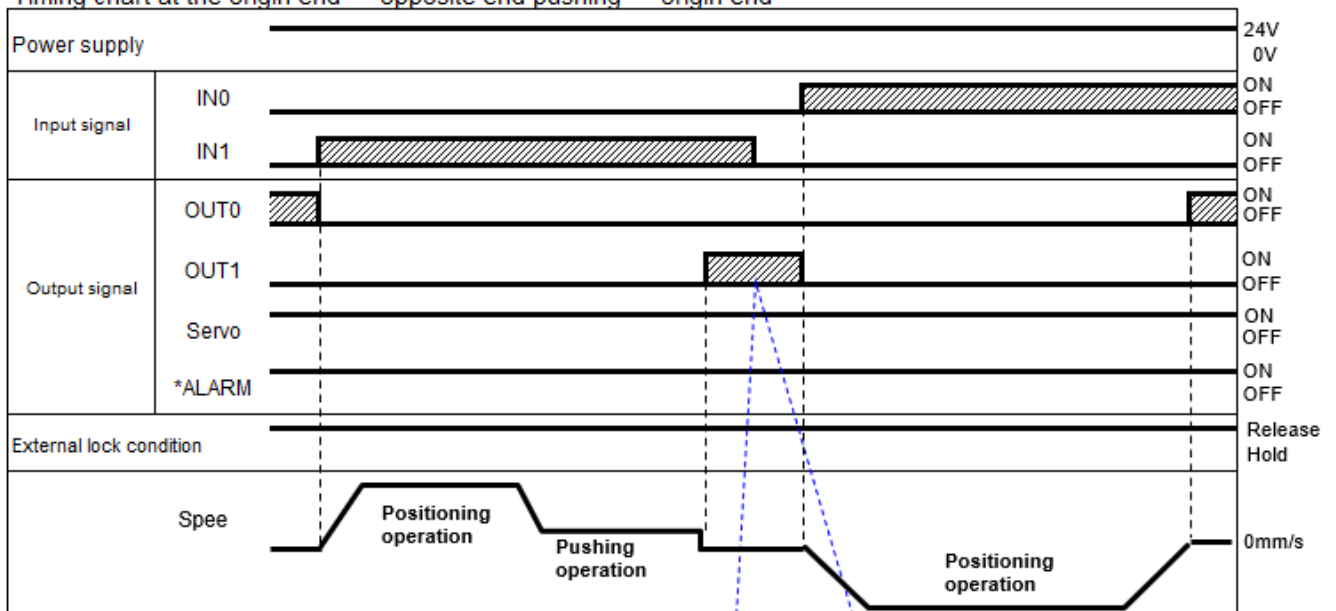
4. When the pushing operation is started and the set pushing force is reached, the OUT0 and OUT1 output signals corresponding to the commanded operation data turn ON to complete the pushing operation.

(Pushing force set by the operation data is generated.)

{ OUT0 output: ON → Completes pushing to the origin end  
 OUT1 output: ON → Completes pushing to the opposite end }

### - Timing chart Pushing operation (Double solenoid mode) -

Timing chart at the origin end → opposite end pushing → origin end



IOU output signal is ON when a force equal to the operation data "pushing force" or more is generated.

\*The \*\*ALARM" is displayed in negative logic.

\*\*Power ON" in the timing chart shows the power supply is turned ON.

\*\*Servo ON" shows that power is supplied to the motor and it is operable.

### (3) Pushing operation using closed mode

#### - Procedure (Closed mode) -

1. Specify a command operation using the operation data by turning IN0 and IN1 inputs ON/OFF.

⇒ Load the specified operation data.

{ IN0 input: ON (IN1: OFF) → Command to move to the origin end  
 IN1 input: ON(IN0: OFF) → Command to move to the opposite end  
 \*Pushing operation cannot be performed at the intermediate point.



2. Starts the positioning operation until the start position for the pushing operation.



3. Starts pushing operation at low speed when it reaches the start position for the pushing operation. [Pushing speed EQY16:25mm/s EQY25:35mm/s EQY32:30mm/s]

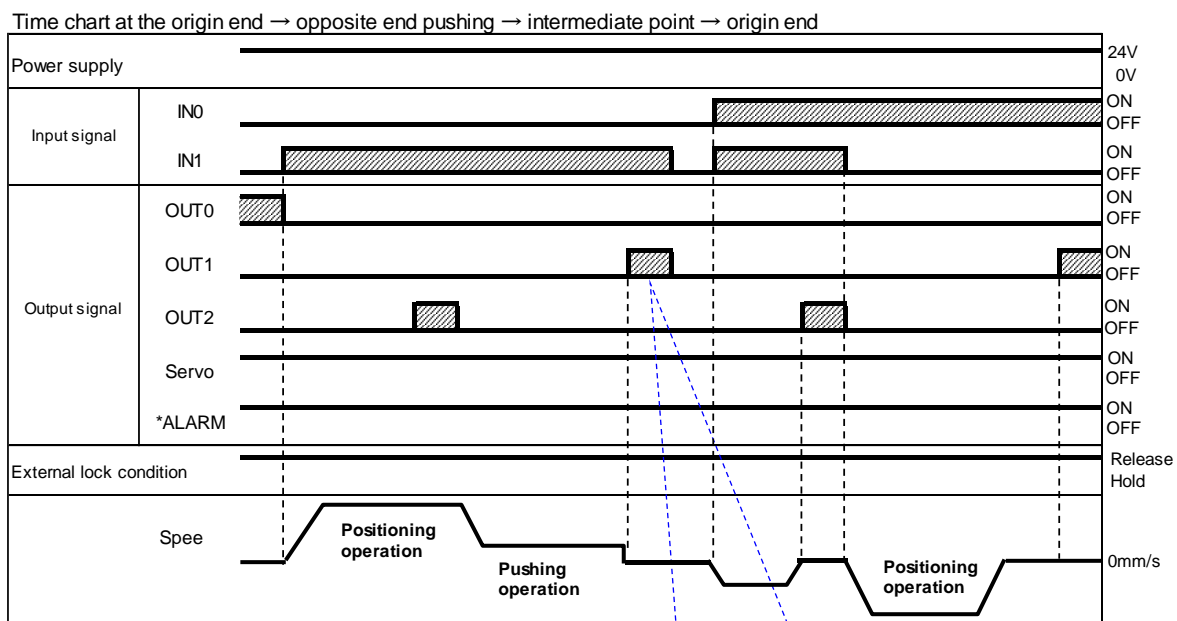


4. When the pushing operation is started and the set pushing force is reached, the OUT0 and OUT1 output signals corresponding to the commanded operation data turn ON to complete the pushing operation.

(Pushing force set by the operation data is generated.)

{ OUT0 output: ON → Completes pushing to the origin end  
 OUT1 output: ON → Completes pushing to the opposite end  
 \*Pushing operation cannot be performed at the intermediate point.

#### - Timing chart Pushing operation (Closed mode) -



\*The "\*"ALARM" is displayed in negative logic.

\*\*"Power ON" in the timing chart shows the power supply is turned ON.

\*\*"Servo ON" shows that power is supplied to the motor and it is operable.

\*The operation stops when the signal of IN0 or IN1 is turned OFF.

IOUT output signal is ON when a force equal to the operation data "pushing force" or more is generated.

### 3.3.4 Reset

#### Alarm reset

**- Procedure -**

(1) Alarm is generated

(\*ALARM output turns OFF.)

↓

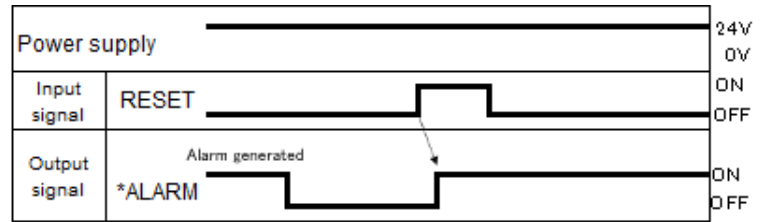
(2) Turn the RESET input ON.

↓

(3) The \*ALARM output turns ON when the generated alarm is of the alarm Groups B to D and the cause of the alarm is solved.

(Alarm will be reset.)

- Timing chart alarm reset-



\*\*\*ALARM\* is displayed in negative logic.

#### Warning

Thoroughly check safety before resetting the alarm since the operation described below will be performed according to the mode immediately after the alarm is reset by the RESET signal.

• Single solenoid mode or closed center mode:

When the alarm is reset, the command from the upper-level device such as a PLC will take effect, and the operation commanded by the upper-level device will be operated immediately.

• Double solenoid mode:

The operation commanded by the upper-level device such as a PLC at the generation of the alarm will be performed immediately after the alarm is reset. (Even if both IN0 and IN1 commands are turned OFF at reset, the operation commanded at the generation of the alarm will be performed.)

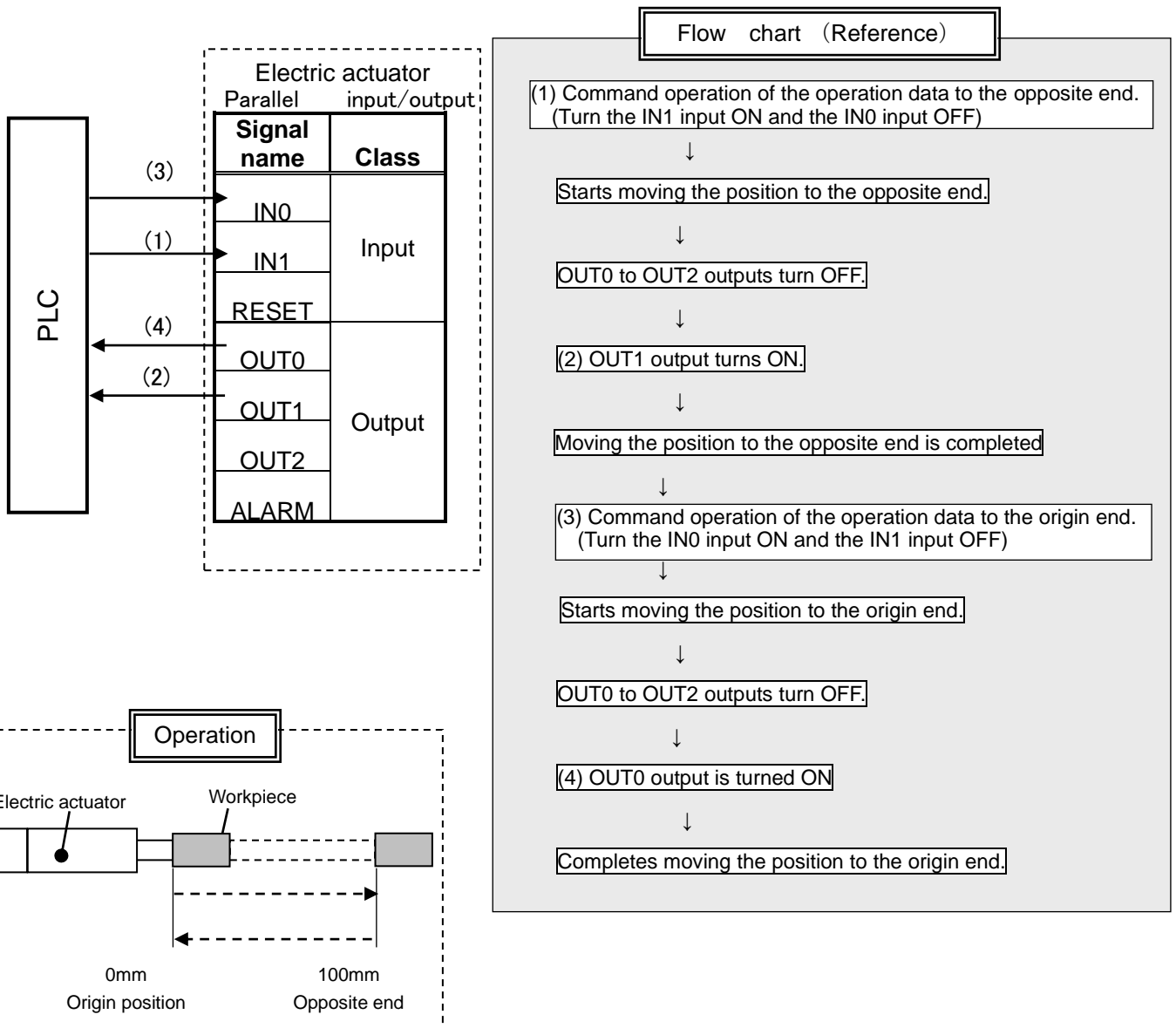
### 3.4 Operation Examples

#### 3.4.1 Positioning operation

Example) A setting example in double solenoid mode is described when it is moved from the origin end (0 mm position) to the opposite end (100 mm position) with a speed of 100 mm/s (operation command to the opposite end) and then moved from the opposite end (100 mm position) to the origin end (0 mm position) with a speed of 300 mm/s (operation command to the intermediate point).

#### ■ Operation data setting example (Double solenoid mode)

No.	Position mm	Speed mm/s	Acceleration mm/s <sup>2</sup>	Deceleration mm/s <sup>2</sup>
1	Origin end	0.00	300	3000
2	Opposite end	100.00	100	3000



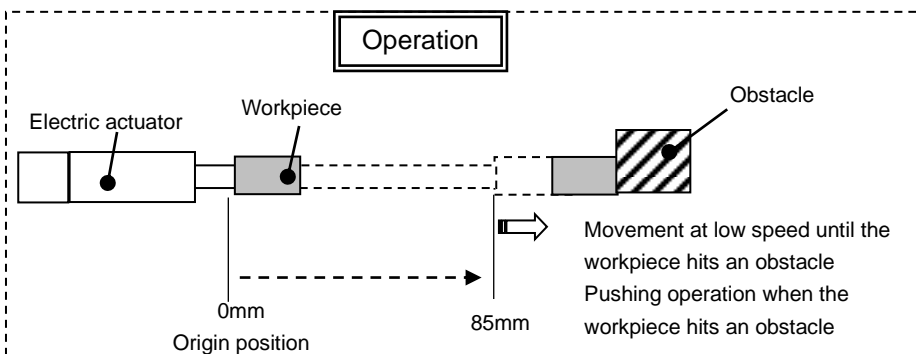
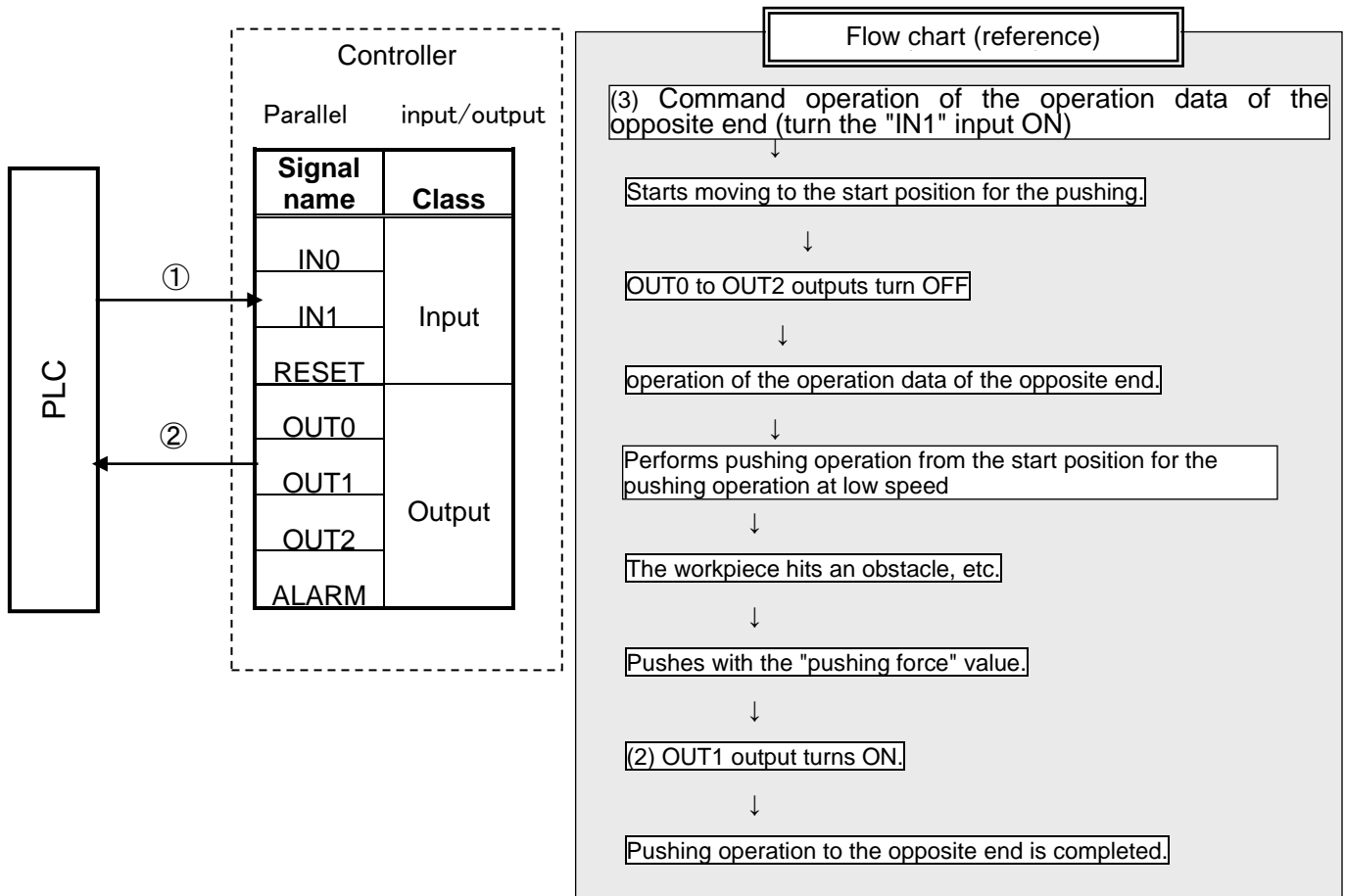
### 3.4.2 Pushing operation

Example) A setting example in closed center mode is described when it is moved from the origin end to the position 85 mm from the start position for the pushing operation with a speed of 50 mm/s (move command to the opposite end), moved from the 85 mm position to the opposite end in low speed (pushing operation), and when the workpiece hits an obstacle, perform pushing operation with 60% force.

#### ■ Operation data setting example (Closed center mode)

No.	Position mm	Speed mm/s	Acceleration mm/s <sup>2</sup>	Deceleration mm/s <sup>2</sup>	Start position for the pushing operation mm	Pushing force %
1	Origin end	0.00	100	3000	10.00	50
2	Opposite end	100.00	50	3000	85.00	60
3	Intermediate point	40.00	200	3000	Setting not available	Setting not available

\*Pushing to the intermediate point is not available in the closed center mode.



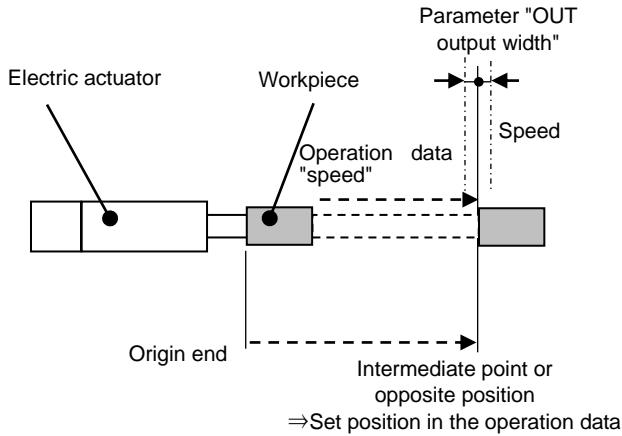


## 4 Operation Mechanism

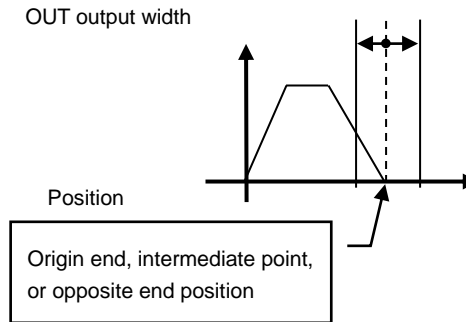
### 4.1 Positioning operation

When a check mark is entered with the setup software in the "Positioning operation" of the operation data, the positioning operation will be set and it will move to the position set as the "origin end, opposite end, and intermediate point" of the operation data using the "speed" and "acceleration/deceleration" set in the operation data.

#### • Positioning operation example



#### • Positioning operation (speed/position) example



### 4.2 Pushing operation

The pushing operation will be performed when a check mark is entered in the "pushing operation" of the operation data of the setup software.

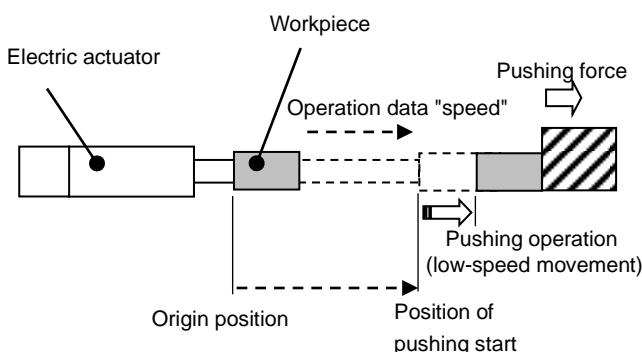
Similar to the normal positioning operation, the positioning operation to the position set in the "start position for the pushing operation" of the operation data will be performed by "speed" and "acceleration/deceleration" set in the operation data, and start the pushing operation from the "start position for the pushing operation."

The force at or below the "pushing force" set in the operation data will be applied during the pushing operation.

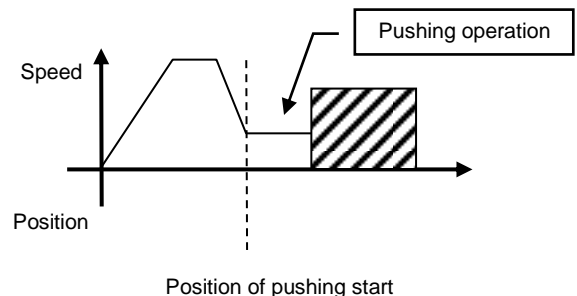
#### (1) When the pushing operation is successful

The OUT output turns ON when the force set in the "pushing force" of the operation data is applied for a certain time. The pushing force will be maintained after the OUT output is turned ON.

#### • Pushing operation example

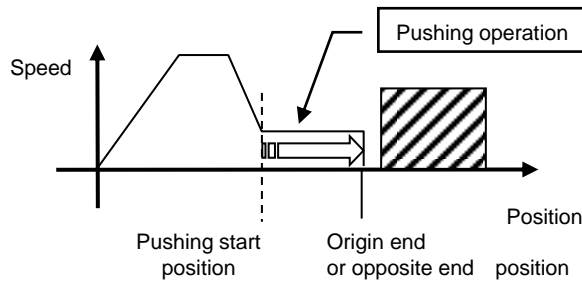


#### • Pushing operation (speed/position) example



## (2) When the pushing operation is unsuccessful (idling)

The pushing operation will stop if the pushing operation is not completed when it is moved from the start position for the pushing operation to the "opposite end or origin end" set in the operation data. In this case, the OUT output will be turned OFF.

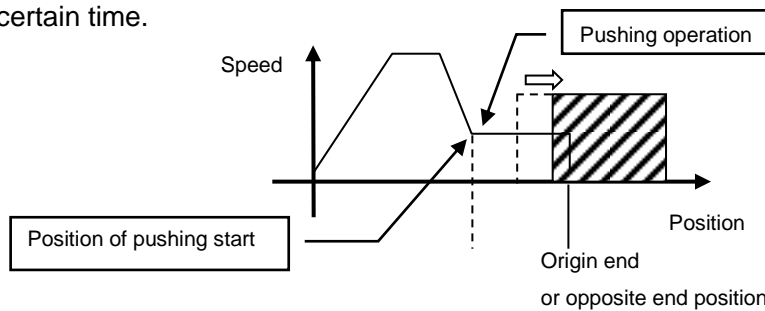


## (3) When the workpiece moves after completing the pushing operation

(1) When the workpiece moves in the pushing direction

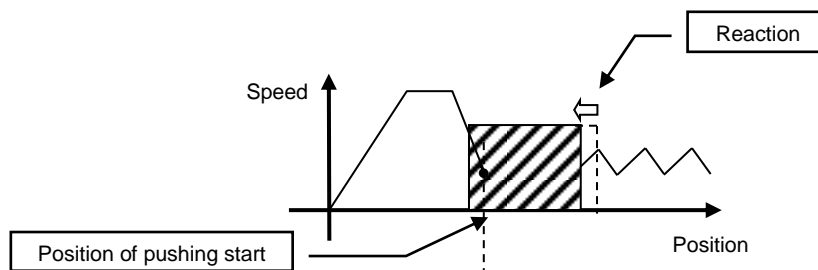
When the electric actuator has moved due to a decrease in the reaction force of the pushing target after the completion of the pushing operation, the OUT output will turn OFF and follows the change to the position set as the "opposite end or origin end" of the operation data.

The OUT output turns ON again when the force set in the "pushing force" of the operation data is applied for a certain time.



(2) If the workpiece moves in the opposite direction of the pushing force (due to a large reaction force from the workpiece) or if the reaction force from the pushing target becomes larger and the electric actuator is pushed back, it continues to be pushed back while OUT output is turned ON until the reaction force and pushing force are balanced.

(The electric actuator will be pushed back toward the start position for the pushing operation.)



### 4.3 Return to origin

The operation to return to origin is required in the events described below.

(1)When the Motor is replaced

(2)When the alarm "Group E" is generated reset the alarm by turning on the power supply again.

(3)The "return to origin direction" parameter is changed

With this electric actuator, the "Absolute encoder ID mismatch error (153)" alarm will be generated when turning on the power supply after "(1) when the motor is replaced." In such a case, reset the alarm and perform the return to origin operation.

The alarm is reset at the shipment from the factory with a brand-new electric actuator. Therefore, the "Absolute encoder ID mismatch error alarm (153)" will not be generated when turning on the power supply in (1).

#### ● Return to the origin operation

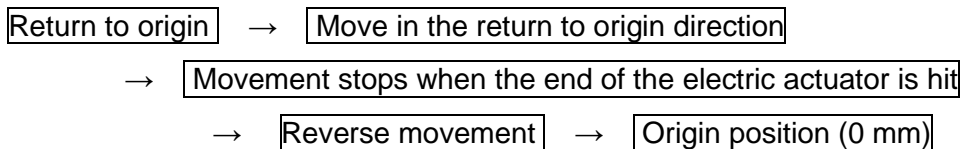
For (1), (2), and (3) described above, the first operation command of IN0 and IN1 after turning on the power supply will be the operation to return to origin.

When the operation to return to origin is performed, the electric actuator moves in the return to origin direction from the initial position when the power supply was turned on. ((1))

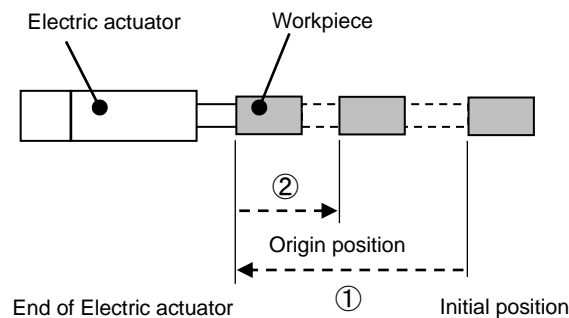
The slider moves to the end of the electric actuator and after a certain time it is stopped, the electric actuator will recognize the position as the end of the electric actuator.

Then, the electric actuator moves at a low speed in the direction opposite to the return to origin direction. ((2))

The position after the movement will be set as the origin position (0 mm position).



#### ●Return to origin operation example



### ⚠ Warning

The operation for the return to origin is performed after resetting the Group E alarm and "Absolute encoder ID mismatch error" alarm or when the operation command is given as the first IN0, IN1 after changing the "return to origin direction" parameter followed by the content of the operation command.

### ⚠ Caution

The return to origin direction of the electric actuator differs according to the electric actuator and the "return to origin direction" parameter.

#### 4.4 Response time in receiving an electric actuator input signal

Factors of the response delay to the electric actuator input signal are described below.

- (1) Delay in electric actuator input signal scan
- (2) Delay in analysis and computing of the input signal
- (3) Delay in analysis and processing of the command

Make sure to have intervals of 15 ms or longer (30 ms is recommended) between input signals and maintain the state of the signal for the same period of time because delay in PLC processing and electric actuator scan can occur.

#### 4.5 Methods of interrupting operation

There are two methods for interrupting the operation and stopping the electric actuator during the positioning operation and pushing operation as described below.

- Shutdown of M24V
- Limited to the closed center mode, turn both IN0 and IN1 input signals OFF

If the M24V is turned OFF during operation, the electric actuator decelerates and stops, and the servo will turn OFF, which does not hold the stopped position. (For an electric actuator with a lock, it is held by the lock function.)

### **Warning**

When the electric actuator is stopped by shutting down M24V, thoroughly check the safety before turning on the power supply to M24V again since the operation described below will be performed immediately after the power supply of M24V is turned on.

- Single solenoid mode or closed center mode:

When the M24V power supply is turned on again, the command from the upper-level device such as a PLC will take effect, and the operation commanded by the upper-level device when the power supply is turned on will be operated immediately.

- Double solenoid mode:

The operation commanded by the upper-level device such as a PLC at the shutdown of M24V will be performed immediately after the M24V power supply is turned on again. (Even if both IN0 and IN1 commands are turned OFF when the power supply to M24V is turned on again, the operation commanded at the shutdown of M24V will be performed.)

## 5 Alarm detection

The details of the alarm can be checked using the setting software.

Refer to the operation manual of the setup software for the alarm checking method.

When an alarm is generated, deactivate the alarm after troubleshooting and correcting the error with reference to **5.2 Alarm details**.

### 5.1 Parallel signal output for the alarm group



The alarm types are categorized into four groups for this electric actuator in which the servo ON condition and the return to origin completion condition according to the alarm group after an alarm is generated are shown in the table below.

Alarm group	Servo ON condition	Return to origin completion condition	Operation restart procedure
Alarm group B	No change	No change	Input RESET
Alarm group C	No change	No change	Input RESET
Alarm group D	OFF	No change Note)	Input RESET Note)
Alarm group E	OFF	OFF	Power supply for control is turned off ⇒ Supply again

\*After the absolute encoder ID mismatch error (01-153) alarm is generated, the operation to return to origin is required when restarting the operation

### 5.2 Alarm details

Electric actuator setup software name (code)	Group	Alarm reset method	Conditions/Countermeasures
Drive data value is wrong (048)	B	Input RESET	<p><b>&lt;Condition&gt;</b> This alarm occurs when the "speed" during pushing operation is less than the "pushing speed".</p> <p><b>&lt;Countermeasure&gt;</b> Set the "speed" to the "pushing speed" or higher. [Pushing speed EQY16:25mm/s EQY25:35mm/s EQY32:30mm/s]</p>
Set stroke is outside the stroke limit. (052)	B	Input RESET	<p><b>&lt;Condition&gt;</b> (1) The current actuator position outside the stroke limit specified by the origin end and opposite end. (2) When the position at completion of return to origin is outside the setting range of the origin end and the opposite end.</p> <p><b>&lt;Countermeasure&gt;</b> If this alarm occurs, please input the RESET signal, and then repeat the operation instruction again.</p>
Return to origin was not completed within the set time (097)	C	Input RESET	<p><b>&lt;Condition&gt;</b> Return to origin is not completed within the set time.</p> <p><b>&lt;Countermeasure&gt;</b> Check if the movement of the actuator was interrupted.</p>
Operation command was provided when the servo was turned OFF (098)	C	Input RESET	<p><b>&lt;Condition&gt;</b> While the servo motor is turned off (24 VDC power supply not supplied to M24V), the positioning operation, pushing operation, or JOG operation command was provided.</p> <p><b>&lt;Countermeasure&gt;</b> If an alarm is generated, command the operation after resetting the alarm and in servo ON condition (24 VDC power supply is turned on for M24V).</p>

Return to origin position is incomplete (099)	C	Input RESET	<p>&lt;Condition&gt; - When changing the parameter "Rotating direction reference" -When alarm group E has occurred. In the above, the alarm occurs when JOG or Inching teaching is indicated from the setting software (e-Actuator setup tool) and the actuator power is turned on again.</p> <p>&lt;Countermeasure&gt; If this alarm occurs, please input the RESET signal first. Then carry out the JOG or Inching teaching after performing a drive test from the setting software (e-Actuator setup tool). (When a drive test is indicated, the "Return to Origin operation" is carried out first.)</p>
The motor was rotated while the initial data of the encoder was communicating (101)	C	Input RESET	<p>&lt;Condition&gt; The Power supply was turned on when the actuator was operating due to an external force.</p> <p>&lt;Countermeasure&gt; Turn the RESET signal ON when the actuator is stopped.</p>
Error occurred during communication with the encoder (106)	C	Input RESET	<p>&lt;Condition&gt; This alarm occurs when an abnormality in communication with the encoder is detected when the power supply is turned on.</p> <p>&lt;Countermeasure&gt; As this error may be caused by noise, check the peripheral devices and remove devices that may be the source of the noise.</p>
The motor speed has exceeded the set value (144)	D	Input RESET	<p>&lt;Condition&gt; The motor speed exceeds the specified value due to an external force or other factors.</p> <p>&lt;Countermeasure&gt; Do not perform any operation that exceeds the maximum speed of the electric actuator.</p> <div data-bbox="584 1167 1498 1296" style="border: 1px solid black; padding: 5px;"> <p style="text-align: center;"> <b>Caution</b></p> <p>Please refer to the operation manual or the catalog of the electric actuator for the maximum speed of the electric actuator.</p> </div>
Motor power supply voltage is outside the set range (145)	D	Input RESET	<p>&lt;Condition&gt; The alarm may be generated by an increase in the regenerative power due to the electric actuator operation method.</p> <p>&lt;Countermeasure&gt; Check if the operating condition of the electric actuator is within the specification range.</p> <div data-bbox="584 1581 1498 1711" style="border: 1px solid black; padding: 5px;"> <p style="text-align: center;"> <b>Caution</b></p> <p>Please refer to the operation manual or the catalog of the electric actuator for the operation method of the electric actuator.</p> </div>
The internal temperature of the electric actuator is above the specified value (146)	D	Input RESET	<p>&lt;Condition&gt; The ambient temperature of the power element in the electric actuator is too high.</p> <p>&lt;Countermeasure&gt; Make improvements so that the temperature around the electric actuator is kept within the specifications.</p>

The control power supply voltage is outside the specifications (147)	D	Input RESET	<b>&lt;Condition&gt;</b> The control power supply voltage is out of the specified range.
			<b>&lt;Countermeasure&gt;</b> Check the voltage supplied to the control power supply (C24V).
A large current was applied for a certain time (148)	D	Input RESET	<b>&lt;Condition&gt;</b> An overload condition occurred for a certain time.
			<b>&lt;Countermeasure&gt;</b> Check that the movement of the electric actuator is not interrupted. In addition, confirm whether the electric actuator load, speed, and acceleration/deceleration are within the specification range.
The target position was not reached within the specified time limit (149)	D	Input RESET	<b>&lt;Condition&gt;</b> The actuator failed to reach the target position within the specified time limit.
			<b>&lt;Countermeasure&gt;</b> Check that the movement of the electric actuator is not interrupted. Confirm whether the electric actuator load, speed, and acceleration/deceleration are within the specification range. When the "Positioning time level" parameter has been set to a low value, reset the value to the default value.
Communication error occurred (150)	D	Input RESET	<b>&lt;Condition&gt;</b> The setup communication cable is not detached after operating the "Simple data setting screen" of the setup software (e-Actuator setup tool).
			<b>&lt;Countermeasure&gt;</b> Detach the setup communication cable after using the setup software (e-Actuator setup tool).
Encoder error (192)	E	Turn off the control power supply	<b>&lt;Condition&gt;</b> Abnormality in communication with the encoder.
			<b>&lt;Countermeasure&gt;</b> As it may be caused by noise, check the peripheral devices and remove devices that may be the source of the noise. Please contact SMC if it cannot be solved.
The output current is abnormally high (194)	E	Turn off the control power supply	<b>&lt;Condition&gt;</b> The output current is abnormally high.
			<b>&lt;Countermeasure&gt;</b> Please contact SMC when this alarm is generated.
Current sensor error (195)	E	Turn off the control power supply	<b>&lt;Condition&gt;</b> (1) Abnormality in the current sensor is detected when the M24V power supply to the electric actuator is turned on. (2) When the power supply capacity is insufficient.
			<b>&lt;Countermeasure&gt;</b> (1) Check whether the electric actuator is operating from an external force when turning on the M24V power supply. When the electric actuator is installed vertically, check whether LK RLS is energized or not. If the alarm is still generated when the power is reapplied, please contact SMC. (2) Please check if the power supply capacity is sufficient or not.

(049)			<b>&lt;Condition&gt;</b> Please contact SMC when this alarm is generated.
(051)			
(103)			
(109)			
(153)	-	-	
(193)			
(197)			<b>&lt;Countermeasure&gt;</b> Please contact SMC when this alarm is generated.
(198)			
(202)			

## **Warning**

Thoroughly check safety before resetting the alarm since the operation described below will be performed according to the mode immediately after the alarm is reset by the RESET signal.

- Single solenoid mode or closed center mode:

When the alarm is reset, the command from the upper-level device such as a PLC will take effect, and the operation commanded by the upper-level device will be operated immediately.

- Double solenoid mode:

The operation commanded by the upper-level device such as a PLC will be performed immediately after the alarm is reset. (Even if both IN0 and IN1 commands are turned OFF at reset, the operation commanded at the generation of the alarm will be performed.)



## 6 Troubleshooting

Refer to the table below for troubleshooting. When the causes in the troubleshooting table cannot be identified and normal operation can be recovered only by replacing the product, the product itself is probably faulty.

The product failure may be due to the operating conditions (application). Please contact SMC for assistance.

### Warning

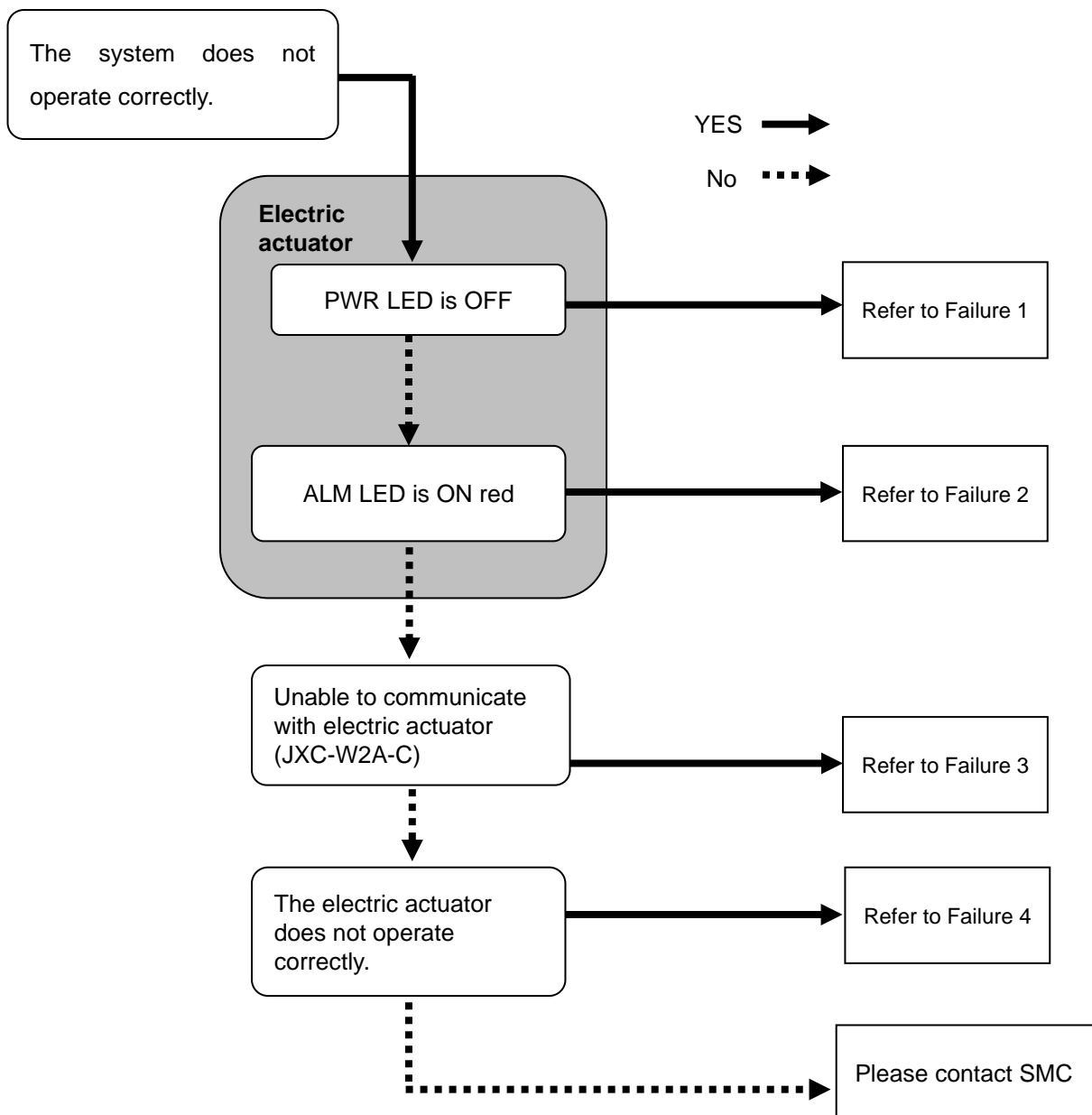
Thoroughly check safety before resetting the alarm since the operation described below will be performed according to the mode immediately after the alarm is reset by the RESET signal.

- Single solenoid mode or closed center mode:

When the alarm is reset, the command from the upper-level device such as a PLC will take effect, and the operation commanded by the upper-level device will be operated immediately.

- Double solenoid mode:

The operation commanded by the upper-level device such as a PLC will be performed immediately after the alarm is reset. (Even if both IN0 and IN1 commands are turned OFF at reset, the operation commanded at the generation of the alarm will be performed.)



Problem No.	Problem	Possible cause	Investigation method and possible cause	Countermeasures
1	LED is OFF.	Power fault	Is the green LED on the electric actuator ON?	Check the voltage and current supplied to the electric actuator. ⇒ <b><u>2.5.1 Connection to input power supply</u></b>
		Incorrect wiring	Check that the wiring is correct.	Check if the wiring is connected correctly or if there is any broken wire or short-circuit by referring to this operation manual. Correct the wiring and check that the input/output of each signal is correct. ⇒ <b><u>2.5.1 Connection to input power supply</u></b> ⇒ <b><u>2.5.3 Connection to PLC</u></b>
2	ALM: LED is ON	Alarm generated	Check if the electric actuator is in an alarm condition.	Refer to this electric actuator operation manual, and take appropriate measures. ⇒ <b><u>5 Alarm detection</u></b>
3	Communication fault (JX-CT-E)	The USB driver is not installed	Check that the USB driver for the communication cable is installed.	Please install the USB driver for the USB cable. The USB driver's installation starts when the communication cable is connected to the PC. Refer to the "Setup software (e-Actuator set up tool) installation procedure" for installation
		Incorrect COM port setting	For details of the COM port setting and checking methods refer to the "Setting software" (e-Actuator Set up tool).	The COM port allocated to the communication cable is different for different PC's. Please confirm the COM port number with the communication cable connected. The COM port number can be checked using the Device Manager of the PC. Refer to the "Setup software (e-Actuator setup tool) installation procedure" for methods to confirm and set the COM port number.
		Connection failure	Check the wiring.	Please confirm Electric actuator = communications cable = USB cable = PC is connected. For example, communication cannot be established if the connector has been damaged. Please confirm that the electric actuator power supply has been turned ON. Communication cannot be established if the power supply is off. If equipment other than the actuator (PLC and measurement equipment) relates to PC, remove these before checking. (There is a possibility that the communication with other equipment interferes in the PC.)

4	Actuator does not operate at all.	Lock release error	When the unlock switch is turned ON or OFF there is an unlocking sound made.	If there is no sound of lock release from the electric actuator with lock, the lock may be broken. If the problem persists, please contact SMC.
		External equipment failure	Check that the PLC connected to the electric actuator operates correctly.	Check the operation by test run using the "Setting software" (e-Actuator Set up tool). If the actuator is operated normally, then a signal output from the PLC is a possible suspect. Refer to the operation manual and take appropriate measures. ⇒ <b><u>7.4.1 Details of parallel input/output signals</u></b>
		Influence of a magnetic force	Check if there is equipment which generates a magnetic force, such as a magnet or electro-magnetic coil near the actuator.	All equipment, which generates a magnetic force, should be kept away from the motor. For example, keep 40 mm minimum distance from the actuator with auto switch.
		Stop command	If the actuator is not energized, the servo will be OFF and does not operate. Check if a voltage of 24 VDC is applied to the M24V terminal.	Apply 24VDC to the M24V terminal.
	Operation stops intermittently	Incorrect wiring	Check that the wiring is correct.	Check if the wiring is connected correctly or if there is any broken wire or short-circuit by referring to this operation manual. Correct the wiring and check that the input/output of each signal is correct. Separate the power supply for the actuator input and the parallel I/O signal power supply. ⇒ <b><u>2.5.1 Connection to input power supply</u></b> ⇒ <b><u>2.5.3 Connection to PLC</u></b>
		Electric noise	Check that the grounding is connected correctly. Are power cables for other equipment and electric actuator cables bundled together?	Connect to Ground correctly. Avoid bundling the cables with power cables of other equipment. Are power cables for other equipment and electric actuator cables bundled together? ⇒ <b><u>2.4 Installation of electric actuators</u></b>
		Incorrect parameters	Check that the parameter values are correct.	Modify the parameters accordingly and check the operation. ⇒ <b><u>2.7 Setup of the operation parameters</u></b> ⇒ <b><u>8 Setting</u></b>
		Voltage drop	Check if there are any temporary voltage drops in the power supply. (When a temporary voltage drop occurs, the M24V terminal of the power supply connector will turn OFF and the electric actuator will stop. However, this stop will be released	There is a possibility of a momentary voltage drop because the capacity of the power supply is insufficient, or if the power supply is the "inrush-current control" type. ⇒ <b><u>7 Specifications</u></b>
		Influence of a magnetic force	Check if there is equipment which generates a magnetic force, such as a magnet or electro-magnetic coil near the actuator.	All equipment, which generates a magnetic force, should be kept away from the motor. For example, keep 40 mm minimum distance from the actuator with auto switch.

	Signal timing	Check the timing of the signal from the PLC to the electric actuator.	Make sure to have intervals of 15 ms or longer (30 ms is recommended) between the input signals and maintain the state of the signal for the same time period because a delay in PLC processing and the electric actuator control scan can occur. ⇒ <b><u>4.4 Response time in receiving an electric actuator input signal</u></b>
	Alarm generated	Is the electric actuator in the alarm condition?	Refer to the operation manual, and take appropriate measures. ⇒ <b><u>5 Alarm detection</u></b>
The actuator does not move to the correct position.	Incorrect Origin position	If it is in a pushing operation, repeat a return to origin operation several times to check if the electric actuator returns to the origin correctly.	Perform the return to origin operation several times to check the origin position. Take other measures to make the electric actuator operate normally (remove foreign matter that interferes with the actuator)
	Incorrect parameters	Check that the parameter values are appropriate and the program is correct.	Check the maximum speed, maximum acceleration speed, and maximum deceleration speed of the electric actuator again, and then be sure to enter the correct parameters to check for correct operation. ⇒ <b><u>2.7 Setup of the operation parameters</u></b> ⇒ <b><u>8 Setting</u></b>
Does not move to the correct position.	Incorrect wiring	Check that the wiring is correct.	Check again if the wiring is connected correctly or if there is any broken wire or short-circuit by referring to the operation manual. Correct the wiring if there is any incorrect wiring and check that the input/output of each signal is correct. In addition, 0 V (GND) of both the electric actuator input power supply and the parallel input/output signal power supply shall be the same. ⇒ <b><u>2.5.1 Connection to input power supply</u></b> ⇒ <b><u>2.5.3 Connection to PLC</u></b>
	Influence of a magnetic force	Check if there is equipment which generates a magnetic force, such as a magnet or electro-magnetic coil near the actuator.	All equipment, which generates a magnetic force, should be kept away from the motor. For example, keep 40 mm minimum distance from the actuator with auto switch.
	Signal timing	Check that the PLC connected to the electric actuator operates correctly.	Make sure to have intervals of 15 ms or longer (30 ms is recommended) between input signals and maintain the state of the signal for the same period because delay in PLC processing and electric actuator control part scan can occur. ⇒ <b><u>4.4 Response time in receiving an electric actuator input signal</u></b>
	Data not stored correctly	Check that the data (step data or parameters) is written correctly?	One of the following actions occurred during data writing (while the power supply LED (green) was on). · Turn off the electric actuator input power supply. · Disconnected/ connected the cables. Input the correct data (step data, parameter) again and confirm the operation. ⇒ <b><u>7 Specifications</u></b> ⇒ <b><u>2.7 Setup of the operation parameters</u></b> ⇒ <b><u>8 Setting</u></b>

Required speed is not achieved	Incorrect parameters	Check that the parameter values are correct.	Check the maximum speed and acceleration speed of the electric actuator and be sure to input the correct parameters. ⇒ <b><u>2.7 Setup of the operation parameters</u></b> ⇒ <b><u>8 Setting</u></b>
	Operation pattern is not suitable.	Check if a trapezoidal acceleration/deceleration is programmed for the actuator operation.	In case of such an operation, the actuator may start slowing down before it reaches the maximum speed. Modify the setting to make the moving distance longer or the acceleration larger. ⇒ <b><u>2.7 Setup of the operation parameters</u></b> ⇒ <b><u>8 Setting</u></b>
	Influence of a magnetic force	Check if there is equipment which generates a magnetic force, such as a magnet or electro-magnetic coil near the actuator.	All equipment, which generates a magnetic force, should be kept away from the motor. For example, keep 40 mm minimum distance from the actuator with auto switch.
	Voltage drop occurred	Check if there are any temporary voltage drops in the power supply. (When a temporary voltage drop occurs, the M24V terminal of the power supply connector will be in low voltage and the electric actuator will stop. However, this stop will be released when the voltage recovers.)	There is a possibility of a momentary voltage drop because the capacity of the power supply is insufficient, or if the power supply is an "inrush-current control" type. ⇒ <b><u>7 Specifications</u></b>

### **Warning**

Thoroughly check safety before resetting the alarm since the operation described below will be performed according to the mode immediately after the alarm is reset by the RESET signal.

- Single solenoid mode or closed center mode:

When the alarm is reset, the command from the upper-level device such as a PLC will take effect, and the operation commanded by the upper-level device will be operated immediately.

- Double solenoid mode:

The operation commanded by the upper-level device such as a PLC will be performed immediately after the alarm is reset. (Even if both IN0 and IN1 commands are turned OFF at reset, the operation commanded at the generation of the alarm will be performed.)

## 7 Specifications

### 7.1 Basic specifications of the product

Basic specifications of the product are shown below.

Item	Specification
Controlled motor	Step motor (servo 24 VDC )
Power supply <sup>Note 1) 2)</sup>	Power supply voltage : 24VDC±10% 【for motor drive power control, stop, lock brake release】
Parallel input	3 inputs
Parallel output	4 outputs (40 mA maximum)
Compatible encoder	Battery-less absolute encoder (resolution: 4096 pulses/rotation)
Serial communication	Serial communication RS485 (For JX-CT□-E cable)
LED display	LED x3 (Green/Orange/Red)
Lock control	Unlocking terminal (applicable to non-excitation magnetizing lock)
Cable length	I/O cable: 10 m maximum Power supply cable : 10m maximum
Cooling method	Natural air cooling
Operating temperature range	0°C to 40°C (No freezing) <sup>Note 3)</sup>
Operating humidity range	90%RH or less (No condensation)
Storage temperature range	-10 to 60°C (No freezing)
Storage humidity range	90%RH or less (No condensation)
Insulation resistance	Between the external terminals and case 50 MΩ (500 VDC)

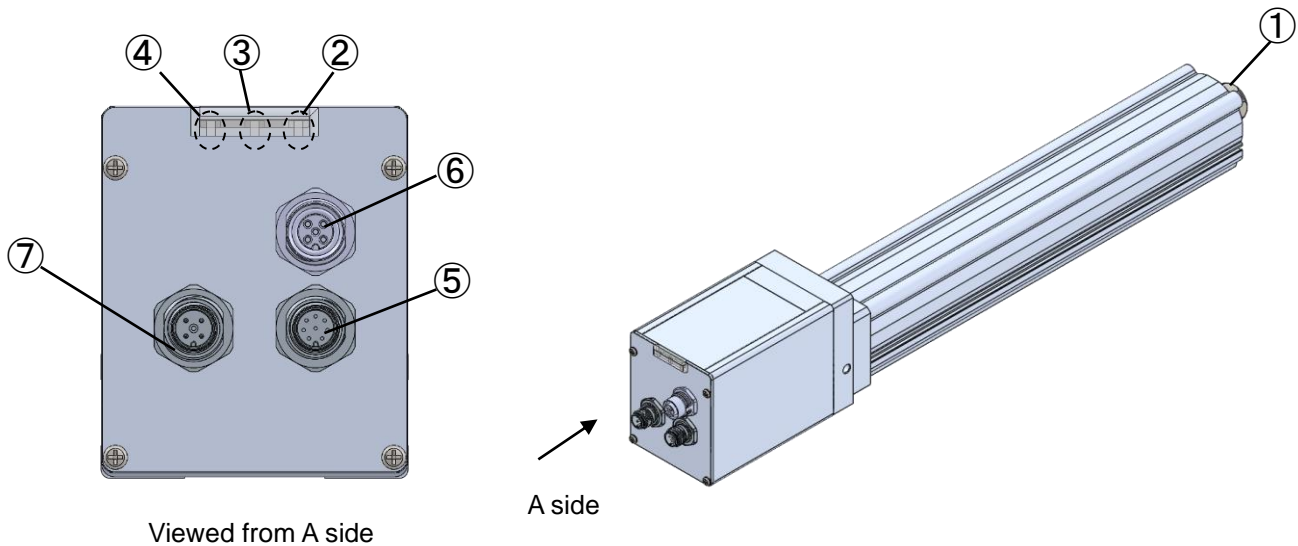
Note 1 ) Do not use the power supply of the “inrush current restraining control type”.

Note 2 ) The power consumption varies depending on the electric actuator model.

Refer to the specifications of the electric actuator for more details.

## 7.2 Parts Description

Details of the parts of the electric actuator.



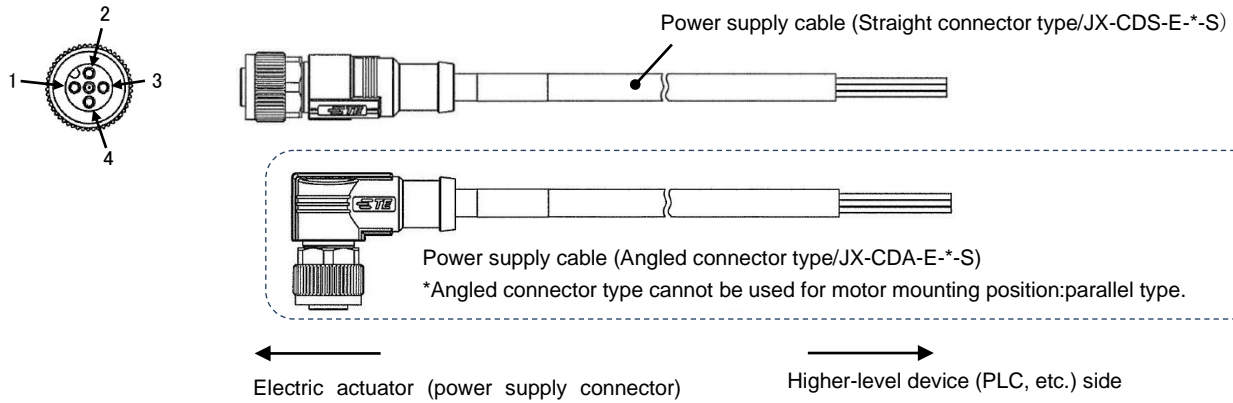
No.	Item	Details
①	Piston rod	Drive terminal Loads and transfers workpieces, etc.
②	Power supply LED (Green)	Power supply ON/No alarm: Green LED is ON Power supply OFF (M24V: OFF, C24V: OFF or ON)
③	Alarm LED (Red)	Red LED is ON: Alarm is generated
④	Over load Warning LED (Orange)	Orange LED is ON: Over-load Warning is generated Indicated operation may be overloaded. Please modify the operation details.
⑤	Parallel I/O Connector (8 pins)	Connect to a PLC using an I/O cable. (3 inputs, 4 inputs)
⑥	Setup Communication Connector (5 pins)	Connects to a PC.
⑦	Power supply connector (4 pins)	Connect to actuator input power supply (24 VDC) using power supply cable. Control power (+)、Motor power (+)、Lock release (+)、Common power (-)

### 7.3 Power supply connector

Connect the power supply cable (JX-CD\*-E-\*-S) to the power supply connector.

When connecting the power supply cable to the power supply connector tighten the socket with a tightening torque of 0.6 N·m.

Specifications of the power supply cable are described below.



<b>Wire conductor size</b>	AWG22
<b>Number of core wires</b>	4
<b>Connector specification</b>	M12, 4-pin socket, A code (Normal key)

Pin No.	Wire color	Terminal name	Function name	Functional explanation
1	Brown	C24V	Control power supply (+)	The control power supply (+) supplied to the electric actuator.
2	White	M24V	Motor power supply (+)	The motor power supply (+) supplied to the electric actuator.
3	Blue	0V	Common power supply (-)	Common for M24V /C24V //LK RLS (-).
4	Black	LK RLS	Lock release (+)	Lock release (+) input.

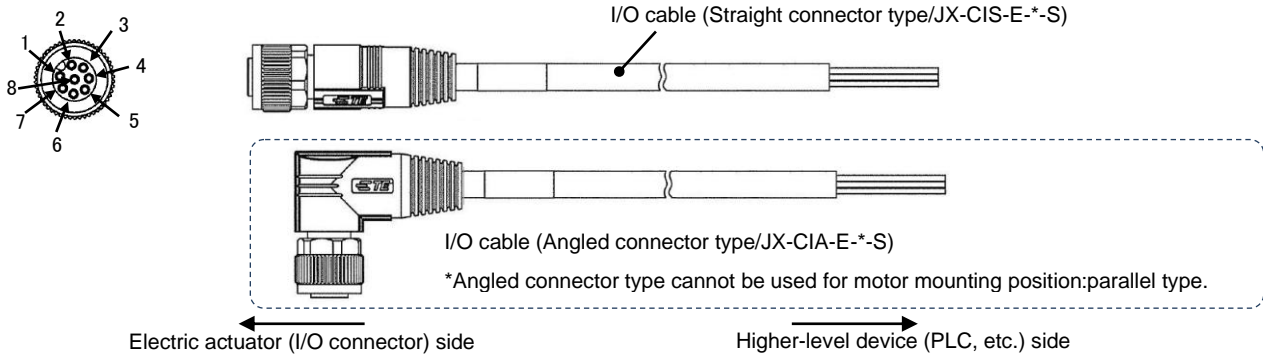


## 7.4 I/O Connector specifications

Connect the I/O cable (JX-CI\*-E-\*-S) to the parallel I/O connector.

When connecting the I/O cable to the parallel I/O connector tighten the socket with a tightening torque of 0.6 N·m.

Specifications of the I/O cable are described below.



<b>Wire conductor size</b>	AWG24
<b>Number of core wires</b>	8
<b>Connector specification</b>	M12, 8-pin socket, A code (Normal key)

### 7.4.1 Details of parallel input/output signals

- Input side -

\*When the I/O cable is green (JX-CI\*-E-\*-S)

Terminal No.	Wire color	Signal name	Description																																				
1	White	INO	The operation data is specified by the combination of ON/OFF of IN0 and IN1 inputs. The combination of IN0 and IN1 inputs for the operation data to command is shown in the table below.																																				
2	Brown	IN1	<table border="1" style="width: 100%; border-collapse: collapse;"> <thead> <tr> <th colspan="2"></th> <th colspan="2" style="text-align: center;">Input</th> </tr> <tr> <th style="text-align: left;">Command operation data</th> <th></th> <th>IN0</th> <th>IN1</th> </tr> </thead> <tbody> <tr> <td style="text-align: center;">Origin end</td> <td></td> <td style="text-align: center;">●</td> <td style="text-align: center;">○</td> </tr> <tr> <td style="text-align: center;">Opposite end</td> <td></td> <td style="text-align: center;">○</td> <td style="text-align: center;">●</td> </tr> <tr> <td style="text-align: center;">Intermediate point</td> <td></td> <td style="text-align: center;">●</td> <td style="text-align: center;">●</td> </tr> <tr> <td colspan="4" style="font-size: small;">*Only for the closed center mode</td> </tr> </tbody> </table> <table border="1" style="width: 50%; border-collapse: collapse;"> <thead> <tr> <th colspan="2"></th> <th style="text-align: center;">Input</th> </tr> <tr> <th style="text-align: left;">Command operation data</th> <th></th> <th>IN1</th> </tr> </thead> <tbody> <tr> <td style="text-align: center;">Origin end</td> <td></td> <td style="text-align: center;">○</td> </tr> <tr> <td style="text-align: center;">Opposite end</td> <td></td> <td style="text-align: center;">●</td> </tr> </tbody> </table> <p style="font-size: small;">○: OFF ●: ON</p>			Input		Command operation data		IN0	IN1	Origin end		●	○	Opposite end		○	●	Intermediate point		●	●	*Only for the closed center mode						Input	Command operation data		IN1	Origin end		○	Opposite end		●
		Input																																					
Command operation data		IN0	IN1																																				
Origin end		●	○																																				
Opposite end		○	●																																				
Intermediate point		●	●																																				
*Only for the closed center mode																																							
		Input																																					
Command operation data		IN1																																					
Origin end		○																																					
Opposite end		●																																					
3	Green	RESET	Resets the alarm.																																				

#### ⚠ Warning

Thoroughly check safety before resetting the alarm since the operation described below will be performed according to the mode immediately after the alarm is reset by the RESET signal.

- Single solenoid mode or closed center mode:

When the alarm is reset, the command from the upper-level device such as a PLC will take effect, and the operation commanded by the upper-level device will be operated immediately.

- Double solenoid mode:

The operation commanded by the upper-level device such as a PLC will be performed immediately after the alarm is reset. (Even if both IN0 and IN1 commands are turned OFF at reset, the operation commanded at the generation of the alarm will be performed.)

#### ⚠ Caution

Make sure to have intervals of 15 ms or longer (30 ms is recommended) between input signals and maintain the state of the signal for the same time period.

- Output side -

\*When the I/O cable is green (JX-CI\*-E-\*-S)

Terminal No.	Wire color	Signal name	Description																
5	Grey	OUT0	<p>The condition where the OUT0, OUT1, and OUT2 outputs turn ON differs when the commanded operation data are for the positioning operation or the pushing operation.</p> <p>[For positioning operation] Turns ON when the current position is within the "Position" +/- "OUT output width" of the operation data.</p>																
6	Pink	OUT1	<p>[For pushing operation] Turns ON when the pushing force is equal to the "pushing force" of the operation data.</p> <p>The OUT0, OUT1, and OUT2 outputs that turn ON by the commanded operation data are shown in the table below.</p> <p style="text-align: right;">○: OFF ●: ON</p> <table border="1" style="margin-left: auto; margin-right: auto;"> <thead> <tr> <th style="text-align: center;">Command operation data \ Output</th> <th style="text-align: center;">OUT0</th> <th style="text-align: center;">OUT1</th> <th style="text-align: center;">OUT2</th> </tr> </thead> <tbody> <tr> <td style="text-align: center;">Origin end</td> <td style="text-align: center;">●</td> <td style="text-align: center;">○</td> <td style="text-align: center;">○</td> </tr> <tr> <td style="text-align: center;">Opposite end</td> <td style="text-align: center;">○</td> <td style="text-align: center;">●</td> <td style="text-align: center;">○</td> </tr> <tr> <td style="text-align: center;">Intermediate point</td> <td style="text-align: center;">○</td> <td style="text-align: center;">○</td> <td style="text-align: center;">●</td> </tr> </tbody> </table>	Command operation data \ Output	OUT0	OUT1	OUT2	Origin end	●	○	○	Opposite end	○	●	○	Intermediate point	○	○	●
Command operation data \ Output	OUT0	OUT1	OUT2																
Origin end	●	○	○																
Opposite end	○	●	○																
Intermediate point	○	○	●																
7	Blue	OUT2																	
8	Red	*ALARM <small>Note 1)</small>	Turned ON when there are no alarms. Turns OFF when an alarm is generated.																

Note 1) \*ALARM is output in negative logic.

Changes in the output signal with respect to the state of the electric actuator are shown in the table below.

Condition signal	Output	OUT*	Servo ON	Lock
Servo ON in the stopped condition after the power supply is turned ON		ON <small>Note 2)</small>	ON	Release
During movement by positioning/pushing operation		OFF	ON	Release
On completion of the positioning operation (when within the OUT output width)		ON <small>Note 2)</small>	ON	Release
Stopped due to pushing a workpiece in pushing operation (maintaining)		ON	ON	Release
Idled and stopped due to no detection of a workpiece during a pushing operation		OFF	ON	Release
Stopped due to shutdown of M24V		OFF <small>Note 2)</small>	OFF	Lock

Note 2) ON when it is within the "OUT output width" of the origin end position, opposite end position, and intermediate point position.

## 7.4.2 Parallel input/output specification

### • Input specification

Items	NPN type	PNP type
Input circuit insulation method	Non-insulated	
Number of inputs	3 points	
Input voltage	-	24 VDC +/- 10 (%)
Input current when ON	5mA	
ON/OFF voltage	ON Voltage: 0V When OFF: OPEN	ON voltage 21.6 VDC or more OFF voltage 4 VDC or less
Current leakage when OFF	1 mA or less	

### • Output specification

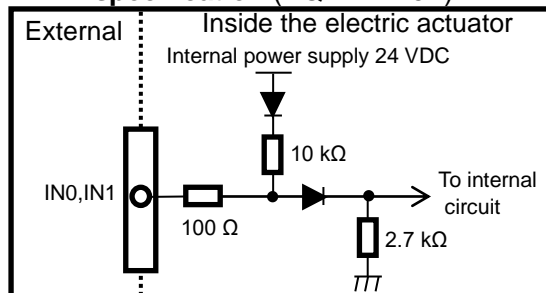
Items	Specification
Output circuit insulation method	Non-insulated
Number of outputs	4 points
Load voltage	24 VDC +/- 10 (%)
Maximum load current	40mA
Residual voltage	2 VDC or less
Current leakage	0.1 mA or less

## 7.4.3 Parallel input/output type actuator circuit (NPN and PNP)

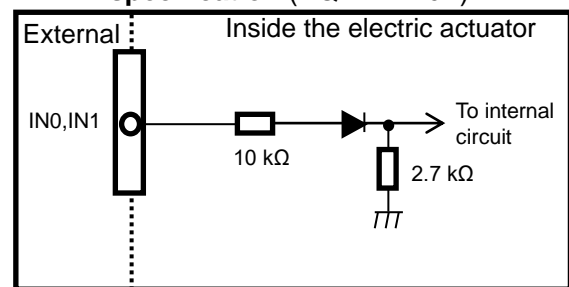
NPN specification and PNP specification are available (parallel I/O type is different between NPN and PNP type) for this electric actuator.

### ■ Parallel I/O input circuit

#### • NPN specification (EQ□□-□-B5□)

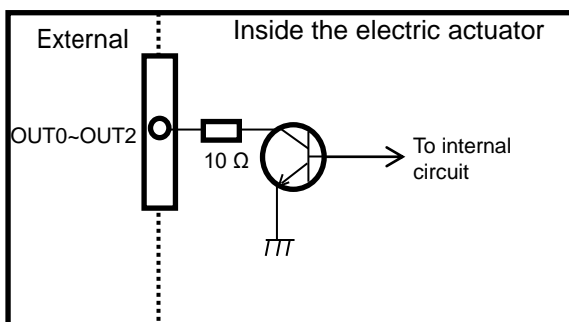


#### • PNP specification (EQ□□-□-B6□)

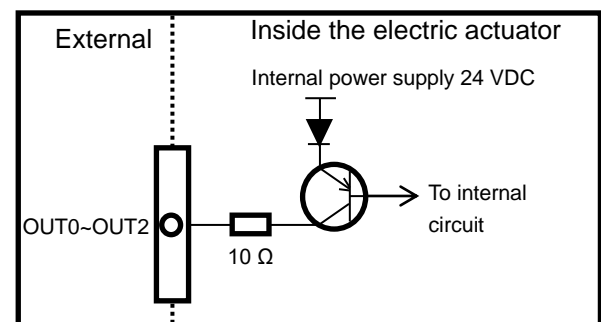


### ■ Parallel I/O output circuit

#### • NPN specification (EQ□□-□-B5□)



#### • PNP specification (EQ□□-□-B6□)



### ⚠ Caution

The parallel input/output of this electric actuator is of a non-isolated specification.

Use the electric actuator input power supply 24 VDC for the power supply of both parallel input and output.

(Use the same input power supply as the control power supply C24V for the parallel input/output power supply.)

## 8 Setting

### 8.1 Operation data

Operation data is the setting for operating the electric actuator.

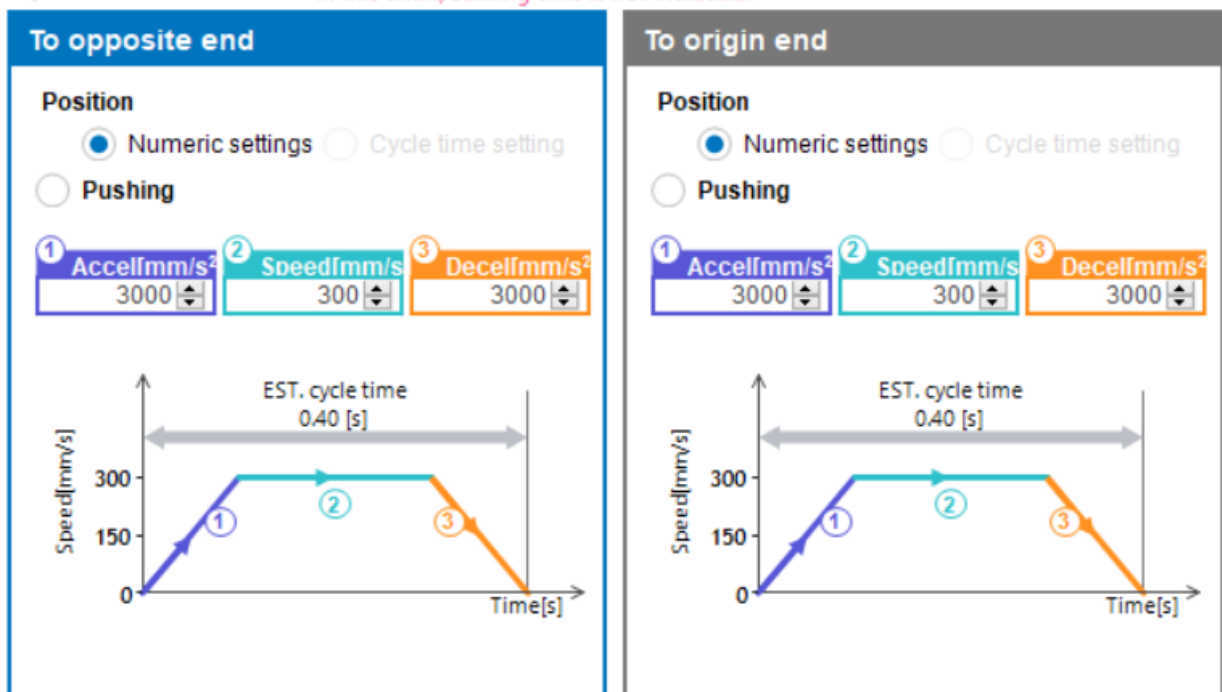
The example shown below is the operation data setting example for the single solenoid mode and double solenoid mode using the e-Actuator setup tool/setup software.

In the closed center mode, the operation data setting screen for the intermediate point is added in the operation condition.

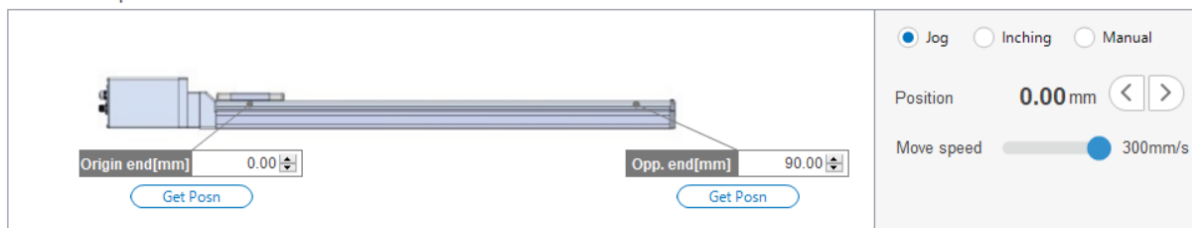
The operation data set in this phase will become effective immediately after it is written in the electric actuator.

Example) Operation data setting of the e-Actuator setup tool/setup software (for single/double solenoid mode)

Operation condition \* In this chart, settling time is not included.



Position setup



### Caution

Write the operation data when the electric actuator in the is stopped condition.

## Details of operation data

Name	Input range	Description
Speed	Minimum value to maximum speed Note 1)	Sets the speed for moving to the target position or the start position for the pushing operation. (Unit: mm/s)
Acceleration	1 to maximum acceleration Note 1)	Sets the acceleration to reach the moving speed. (Unit: mm/s <sup>2</sup> )
Deceleration	1 to maximum acceleration Note 1)	Sets the deceleration from the moving speed to stop. (Unit: mm/s <sup>2</sup> )
Pushing force set values	EQY16: 25~45% EQY25: 25~50% EQY32: 30~70%	Set the ratio of the pressing force.  The maximum pushing force varies depending on each electric actuator. Please check the specification table on page 26.
Origin end	0 to product stroke	Target position of the origin end of the actuator. Or the stop position in pushing operation. (Unit: mm)
Opposite end	0 to product stroke	Target position of the opposite end of the actuator. Or the stop position in pushing operation. (Unit: mm)
Intermediate point	0 to product stroke	Target position of the Intermediate point of the actuator. (Unit: mm)
Pushing position	0 to product stroke	Specifies the position at which the pushing operation starts. (Unit: mm)

Note 1) Please refer to the specification table on page 26.

## 8.2 Parameter

Setting of operation condition and other conditions of the electric actuator.

### Caution

Write the parameter when the electric actuator is in the stopped condition.

### Details of parameters

The parameters can be set using the setup software e-Actuator SETUP tool.

Write column: ☉ = Effective immediately after writing in the electric actuator, ○ = Effective when the power supply is turned on again

Setting	Lead	Default value			Description	Input range	Load
		EQY16	EQY25	EQY32			
Speed	H	Half of the maximum speed of each product			Sets the speed for moving to the target position or to the start position for the pushing operation. (Unit: mm/s)	Input limit value to maximum speed of each product	☉
	A						
	B						
	C						
Acceleration	-	5,000	5,000	5,000	Sets the acceleration to reach the moving speed. (Unit: mm/s <sup>2</sup> )	to 10,000	☉
Deceleration	-	5,000	5,000	5,000	Sets the acceleration to reach the moving speed. (Unit: mm/s <sup>2</sup> )	to 10,000	☉
Pushing force	H	-	76	118	Selects the pushing operation or the positioning operation from the set value.	EQY16: 25 to 45[%] EQY25: 25 to 50[%] EQY32: 30 to 70[%]	☉
	A	38	122	189	For the pushing operation, this value specifies the force to be generated as a percentage of the maximum pushing force. (Unit: %)		
	B	74	238	370	The maximum pushing force depends on the electric actuator, Please refer to the operation manual and the rated force of the electric actuator.		
	C	141	452	707			
Origin end position	-	0	0	0	Sets the target position. (Unit: mm)	0 to Product stroke	☉
Opposite end position	-	Product stroke			Sets the target position. (Unit: mm)	0 to Product stroke	☉
Intermediate point position	-	Half of product stroke			Sets the target position. (Unit: mm)	0 to Product stroke	☉
Start position for the pushing operation	-	Product stroke			Sets the start position for the pushing operation in the pushing operation. (Unit: mm)	0 to Product stroke	☉
OUT signal output width	-	0.5	0.5	0.5	Sets the width to turn the OUT signal ON during the positioning operation. The OUT signal turns ON in the target position ± setting value. (Unit: mm)	0.01 to Product stroke	☉
Rotating direction reference *1	-	In-line: 1 Parallel: 2			Change the coordinate of the electric actuator. The direction will be opposite from the return to the origin when the setting is changed. Therefore, the return to the origin is required.*1	1: Normal direction 2: Reverse direction	○
Acceleration and Deceleration ratio	-	10	10	10	Sets the level of followability of acceleration/deceleration. Followability to the acceleration becomes loose as the setting value increases. (Becomes close to the trapezoidal acceleration as the setting value reaches 0)	10 to 100	☉
Torque when held*2	-	70	50	70	Sets the torque when stopped after the positioning operation. (Unit: %)	EQY16: 1 to 70 EQY25: 1 to 50 EQY32: 1 to 70	☉
Position loop P constant	H	-	150	100	Sets the position loop P constant. ※Please perform the actuator operation after changing this parameter setting under the responsibility of the user.	1 to 200	☉
	A	100	150	100			
	B	60	150	100			
	C	80	90	100			
Speed loop P constant	H	-	130	140	Sets the speed loop P constant. ※Please perform the actuator operation after changing this parameter setting under the responsibility of the user.	1 to 200	☉
	A	160	13	140			
	B	140	140	100			
	C	120	130	120			
Speed loop I constant	H	-	80	100	Sets the speed loop I constant. ※Please perform the actuator operation after changing this parameter setting under the responsibility of the user.	10 to 200	☉
	A	130	100	100			
	B	130	100	80			
	C	60	100	100			
Positioning time level	-	2	2	2	Sets the time to generate the positioning time error alarm. (Unit: s)	0.1 to 25.5	☉

\*1 After changing the rotation direction reference and turning on the power again, return to origin is executed with the first movement command. If movement is obstructed during this return to origin, normal return to origin will not be possible. Therefore, make sure that there are no obstacles or loads within the movable range before returning to the origin so that the actuator can perform the full stroke operation.

 **Caution**

- The direction in which the electric actuator returns to its origin depends on the electric actuator and the "rotation direction reference" parameter.
- If movement is obstructed during the return to origin, a normal return to origin will not be possible. Therefore, make sure that there are no obstacles or loads within the movable range before returning to origin so that the actuator can perform the full stroke operation.

\*2 For vertical use, do not change the torque when held from the Default value.  
For horizontal use, it is possible to lower the torque when held from the Default value, but after changing the torque when held, check if there is any problem with the behavior when the actuator stops.

## 9 Optional parts (sold separately)

The optional parts described below are available (sold separately).

- Power supply cable
- I/O cable
- Setup communication cable
- e-Actuator setup tool/setup software (download from SMC webpage)

### 9.1 Power supply cable

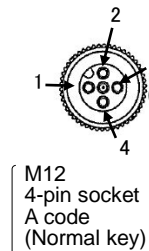
#### JX-CD□-E-□-S

● Cable length (L[m])

1	1.5
3	3
5	5
10	10

● Connector type

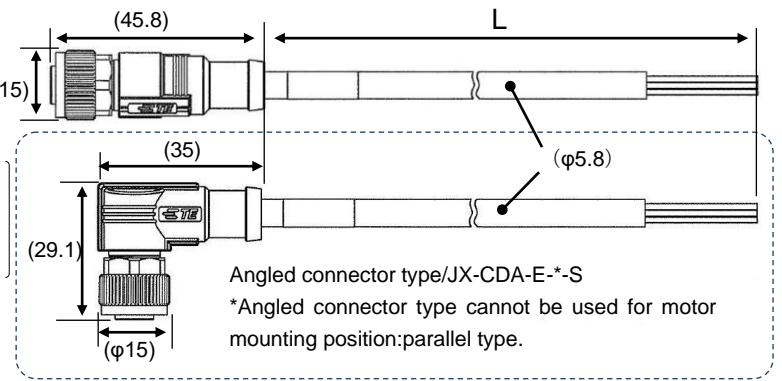
S	Straight
A	Angle



M12  
4-pin socket  
A code  
(Normal key)

\*The terminal on PLC

Straight connector type/JX-CDS-E-\*S



Electric actuator (power supply connector) side

Electric actuator input power supply side

### 9.2 I/O cable

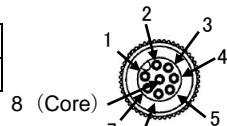
#### JX-CI□-E-□-S

● Cable length (L[m])

1	1.5
3	3
5	5
10	10

● Connector type

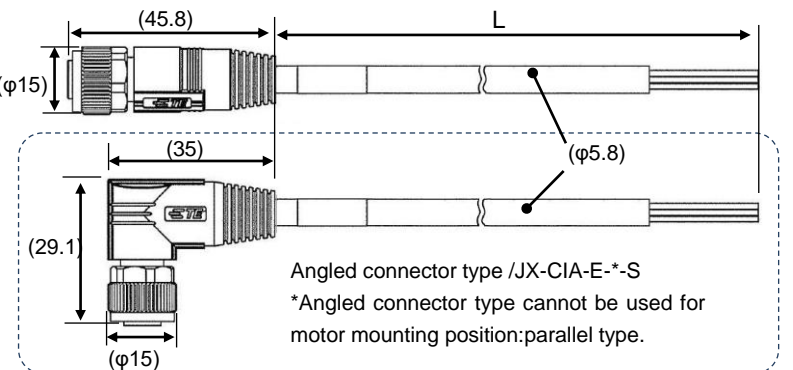
S	Straight
A	Angle



M12  
8-pin socket  
A code  
Normal key

\*The terminal on PLC

Straight connector type /JX-CIS-E-\*S



Electric actuator (parallel I/O connector) side

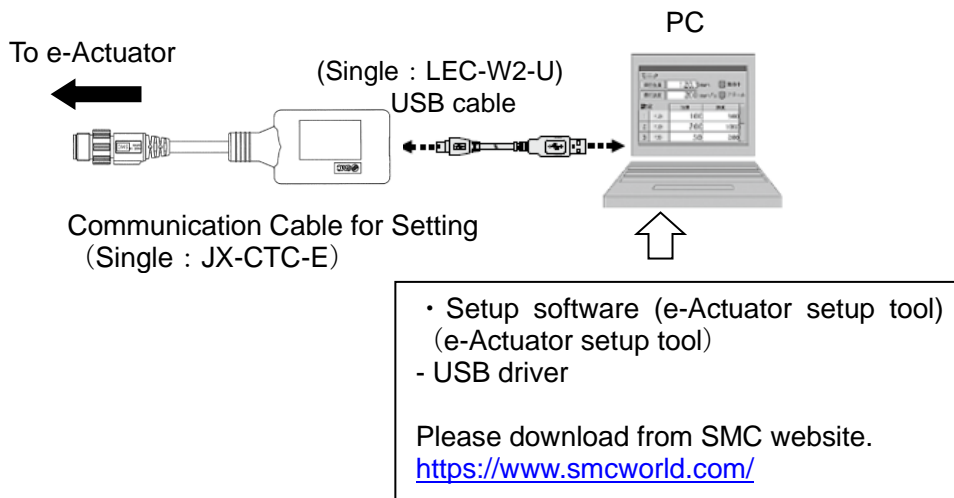
Higher-level device (PLC, etc.)



## 9.3 Setup communication cable

### JX-CT-E

\*Setup communication cable and USB cable (supplied as a set).



## 9.4 Configuration software

### e-Actuator setup tool

#### ■ Operating environment

OS	Windows®10(64bit) Windows®11(64bit)
Communication interface	USB1.1 or USB2.0 port
Display	1024x768 or more

□ Windows®10, and Windows®11 are registered trademarks of United States Microsoft Corporation.

### ⚠ Caution

Please obtain the USB driver and the setup software (e-Actuator setup tool) from SMC website.  
Use the latest version for the setup software.  
Download the upgrade file from the SMC website.

<http://www.smcworld.com/>

#### Revision history

January 2023 : First edition  
March 2023 : Second edition  
December 2023 : Third edition

## SMC Corporation

4-14-1, Sotokanda, Chiyoda-ku, Tokyo 101-0021 JAPAN  
Tel: + 81 3 5207 8249 Fax: +81 3 5298 5362  
URL <https://www.smcworld.com>

---

Note: Specifications are subject to change without prior notice and any obligation on the part of the manufacturer.  
© 2023SMC Corporation All Rights Reserved

