



Operation Manual

PRODUCT NAME

Solid State Auto Switch

MODEL / Series / Product Number

D-M9#A#

SMC Corporation

Table of Contents

Safety Instructions	2
Model Indication and How to Order	9
Summary of Product parts	11
Definition and terminology	11
Mounting and Installation	12
Installation	12
Circuit diagram	13
Troubleshooting	14
Specification	18
Specifications	18
Dimensions	19



Safety Instructions

These safety instructions are intended to prevent hazardous situations and/or equipment damage. These instructions indicate the level of potential hazard with the labels of “**Caution**,” “**Warning**” or “**Danger**.” They are all important notes for safety and must be followed in addition to International Standards (ISO/IEC)^{*)}, and other safety regulations.

*) ISO 4414: Pneumatic fluid power - General rules and safety requirements for systems and their components
ISO 4413: Hydraulic fluid power - General rules and safety requirements for systems and their components
IEC 60204-1: Safety of machinery - Electrical equipment of machines - Part 1: General requirements
ISO 10218-1: Robots and robotic devices - Safety requirements for industrial robots - Part 1: Robots
etc.



Danger

Danger indicates a hazard with a high level of risk which, if not avoided, will result in death or serious injury.



Warning

Warning indicates a hazard with a medium level of risk which, if not avoided, could result in death or serious injury.



Caution

Caution indicates a hazard with a low level of risk which, if not avoided, could result in minor or moderate injury.



Warning

1. The compatibility of the product is the responsibility of the person who designs the equipment or decides its specifications.

Since the product specified here is used under various operating conditions, its compatibility with specific equipment must be decided by the person who designs the equipment or decides its specifications based on necessary analysis and test results. The expected performance and safety assurance of the equipment will be the responsibility of the person who has determined its compatibility with the product. This person should also continuously review all specifications of the product referring to its latest catalog information, with a view to giving due consideration to any possibility of equipment failure when configuring the equipment.

2. Only personnel with appropriate training should operate machinery and equipment.

The product specified here may become unsafe if handled incorrectly. The assembly, operation and maintenance of machines or equipment including our products must be performed by an operator who is appropriately trained and experienced.

3. Do not service or attempt to remove product and machinery/equipment until safety is confirmed.

1. The inspection and maintenance of machinery/equipment should only be performed after measures to prevent falling or runaway of the driven objects have been confirmed.
2. When the product is to be removed, confirm that the safety measures as mentioned above are implemented and the power from any appropriate source is cut, and read and understand the specific product precautions of all relevant products carefully.
3. Before machinery/equipment is restarted, take measures to prevent unexpected operation and malfunction.

4. Our products cannot be used beyond their specifications. Our products are not developed, designed, and manufactured to be used under the following conditions or environments. Use under such conditions or environments is not covered.

1. Conditions and environments outside of the given specifications, or use outdoors or in a place exposed to direct sunlight.
2. Use for nuclear power, railways, aviation, space equipment, ships, vehicles, military application, equipment affecting human life, body, and property, fuel equipment, entertainment equipment, emergency shut-off circuits, press clutches, brake circuits, safety equipment, etc., and use for applications that do not conform to standard specifications such as catalogs and operation manuals.
3. Use for interlock circuits, except for use with double interlock such as installing a mechanical protection function in case of failure. Please periodically inspect the product to confirm that the product is operating properly.



Safety Instructions

Caution

We develop, design, and manufacture our products to be used for automatic control equipment, and provide them for peaceful use in manufacturing industries.

Use in non-manufacturing industries is not covered.

Products we manufacture and sell cannot be used for the purpose of transactions or certification specified in the Measurement Act.

The new Measurement Act prohibits use of any unit other than SI units in Japan.

Limited warranty and Disclaimer/Compliance Requirements

The product used is subject to the following “Limited warranty and Disclaimer” and “Compliance Requirements”.

Read and accept them before using the product.

Limited warranty and Disclaimer

1. The warranty period of the product is 1 year in service or 1.5 years after the product is delivered, whichever is first.*2)
Also, the product may have specified durability, running distance or replacement parts. Please consult your nearest sales branch.
2. For any failure or damage reported within the warranty period which is clearly our responsibility, a replacement product or necessary parts will be provided.
This limited warranty applies only to our product independently, and not to any other damage incurred due to the failure of the product.
3. Prior to using SMC products, please read and understand the warranty terms and disclaimers noted in the specified catalog for the particular products.

***2) Vacuum pads are excluded from this 1 year warranty.**

A vacuum pad is a consumable part, so it is warranted for a year after it is delivered.

Also, even within the warranty period, the wear of a product due to the use of the vacuum pad or failure due to the deterioration of rubber material are not covered by the limited warranty

Compliance Requirements

1. The use of SMC products with production equipment for the manufacture of weapons of mass destruction (WMD) or any other weapon is strictly prohibited.
2. The exports of SMC products or technology from one country to another are governed by the relevant security laws and regulations of the countries involved in the transaction. Prior to the shipment of a SMC product to another country, assure that all local rules governing that export are known and followed.

Operator

- ◆ This operation manual is intended for those who have knowledge of machinery using pneumatic equipment, and have sufficient knowledge of assembly, operation and maintenance of such equipment. Only those persons are allowed to perform assembly, operation and maintenance.
- ◆ Read and understand this operation manual carefully before assembling, operating or providing maintenance to the product.

■ Safety Instructions

Warning

- Do not disassemble, modify (including changing the printed circuit board) or repair.
An injury or failure can result.
- Do not operate the product outside of the specifications.
Do not use for flammable or harmful fluids.
Fire, malfunction, or damage to the product can result.
Verify the specifications before use.
- Do not operate in an atmosphere containing flammable or explosive gases, with dust.
Fire or an explosion can result.
This product is not designed to be explosion proof.
- If using the product in an interlocking circuit:
 - Provide a double interlocking system, for example a mechanical system.
 - Check the product regularly for proper operation.
Otherwise malfunction can result, causing an accident.
- The following instructions must be followed during maintenance:
 - Turn off the power supply.
 - Stop the air supply, exhaust the residual pressure and verify that the air is released before performing maintenance.
Otherwise an injury can result.

Caution

- Do not touch terminals and printed circuit board inside the product.
Otherwise it can cause electric shock, malfunction or damage to the product can result.
- After maintenance is complete, perform appropriate functional inspections.
Stop operation if the equipment does not function properly.
Safety cannot be assured in the case of unexpected malfunction.

Cylinders or actuators include cylinders, air grippers, rotary actuators, and electrical actuators/cylinders.

Design/Selection

1. Confirm the specifications.

If the product is used with excess load applied or beyond the specification range, this may cause the product to break or malfunction. We do not guarantee against any damage if the product is used outside of the specification range.

2. Pay attention to the length of time that a switch is ON at an intermediate stroke position.

When an auto switch is placed at an intermediate position of the stroke and a load is driven at the time the piston passes, the auto switch will operate, but the operating time will be short if the speed is too fast. As a result, the load may not operate completely. The maximum detectable piston speed is:

$$V[\text{mm/s}] = \frac{\text{Auto switch operating range [mm]}}{\text{Time load applied [ms]}} \times 1000$$

3. Take precautions when multiple cylinders/ actuators are used close together.

When multiple auto switch cylinders/actuators are used in close proximity, magnetic field interference may cause the auto switches to malfunction. Maintain a minimum cylinder separation of 40 mm. (When the allowable interval is specified for each cylinder series, use the indicated value.)

The auto switches may malfunction due to the interference from the magnetic fields.

Use of a magnetic screen plate (MU-S025) or commercially available magnetic screen tape can reduce the interference of magnetic force.

4. Ensure sufficient clearance for maintenance activities.

When designing an application, be certain to allow sufficient clearance for maintenance.

5. Do not mount the cylinder or actuator with the auto switch on a footing.

If work personnel gets on or puts the work personnel's foot on the footing accidentally, an excessive load is applied to the cylinder or actuator, causing the cylinder or actuator to break.

6. Design the circuit so that any back-flow current does not flow in if a short-circuit trouble occurs or forced operation is performed to check the operation.

If a back-flow current occurs, this may cause the switch to malfunction or break.

7. When multiple auto switches are required.

"n" indicates the number of auto switches which can be physically mounted on the cylinders/actuators. Detection intervals depends on the auto switch mounting structure and set position, therefore some required interval and set positions may not be available.

8. Limitations on detectable position

There are positions or surfaces (bottom surface of the foot bracket, etc.) where the auto switch cannot be mounted due to the physical interference depending on the cylinder or actuator mounting status or mounting bracket. Select an appropriate auto switch setting position where the auto switch does not interfere with the cylinder or actuator mounting bracket (trunnion or reinforcing ring) after checking it sufficiently.

9. Keep wiring as short as possible.

Be sure to use a wire length of 100 m or less.

When the wire length is long, we recommend the ferrite core is attached to the both ends of the cable to prevent excess noise. A contact protection box is not necessary for solid state switches due to the nature of this product construction.

10. Do not use a load that generates surge voltage.

If driving a load such as a relay that generates a surge voltage, use a built-in surge absorbing element type device.

11. Pay attention to the internal voltage drop of the auto switch.

Generally, the internal voltage drop of the solid state auto switch is larger than that of the reed auto switch. When the auto switches ("n" pcs.) are connected in series, the voltage drop is multiplied by "n". In this case, the auto switches operate correctly, but the loads may not operate. Additionally, note that the 12 VDC relay does not apply to the auto switch.

12. Pay attention to leakage current.

<2-wire type>

Current (leakage current) flows to the load to operate the internal circuit when in the OFF state.

Operating current of load (OFF condition) > Leakage current

If the criteria given in the above formula are not met, it will not reset correctly (stays ON).

Use a 3-wire auto switch if this specification will not be satisfied.

Moreover, leakage current flow to the load will be "n" times larger when "n" auto switches are connected in parallel.

13. Output operation of the solid state auto switch is not stable for 50 [ms] after powered ON.

In the output operation immediately after powered ON or AND connection operation, the input device (PLC or relay, etc.) may judge the ON position as OFF output or the OFF position as ON output.

So, please make the setting on the equipment so that the input judgement signal is set disabled for 50 [ms] immediately after powered ON or AND connection.

When using SMC's AHC system (Auto Hand Changing System) Series MA, please also make this setting.

Mounting/Adjustment

1. Do not drop or bump.

Do not drop, bump, or apply an excessive impact (300 m/s² or more for reed auto switches, 1000 m/s² or more for solid state auto switches) while handling the auto switch. It may cause the auto switch to break or malfunction.

2. Observe the proper tightening torque for mounting an auto switch.

When an auto switch is tightened beyond the range of tightening torque, auto switch mounting screws, auto switch mounting brackets or auto switch may be damaged.

On the other hand, tightening below the range of tightening torque may allow the auto switch to slip out of position.

3. Do not carry a cylinder by the auto switch lead wires.

This may cause disconnection of the lead wire or the internal element to break.

4. Do not use screws other than the set screws installed on the auto switch body to secure the auto switch.

If using other screws, auto switch may be damaged.

5. Mount an auto switch at the center of the operating range.

In the case of 2-color display auto switch, mount it at the center of the green LED illuminating range.

Adjust the mounting position of the auto switch so that the piston stops at the center of the operating range.

(The mounting position shown in the catalog indicates the optimum position at stroke end.)

If mounted at the end of the operating range (around the borderline of ON and OFF), operation will be unstable depending on the operating environment. Also there are some cylinders or actuators with individual setting methods for auto switches. If so, mount it in accordance with the indicated method.

Even if 2-color indication solid state auto switches are fixed at a proper operating range (the green light lights up), the operation may become unstable depending on the installation environment or magnetic field disturbance. (Magnetic body, external magnetic field, proximal installation of cylinders with built-in magnet and actuators, temperature change, other factors for magnetic force fluctuation during operation, etc.)

6. Check the actual actuation status and adjust the auto switch mounting position.

According to the installation environment, the cylinder or actuator may not operate even at its proper mounting position. Even when setting at a midpoint of the stroke, check the actuation status and make the adjustment in the same manner.

Wiring

1. Confirm proper insulation of wiring.

If there is any improper insulation (mixed contact with other circuit, grounding fault, or improper insulation between terminals, etc.) in the wiring, an over-current flows in, causing the auto switch to break.

2. Wire separately from power lines or high voltage lines, avoiding parallel wiring or wiring in the same conduit with these lines.

If an inrush current is generated, the noise may cause the auto switch to malfunction.

3. Avoid repeatedly bending or stretching lead wires.

Broken lead wires will result from repeatedly applying bending stress or stretching force to the lead wires.

Stress and tensile force applied to the connection between the lead wire and auto switch increases the possibility of disconnection.

Keep the lead wire from moving especially in the area where it connects with the auto switch.

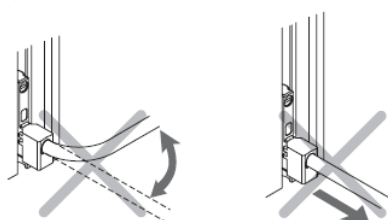

4. Be certain to connect the load before power is applied.

<2-wire type>

If the power is turned ON when an auto switch is not connected to a load, the auto switch will be instantly damaged because of excess current (short circuit).

It is the same as when the 2-wire brown lead wire (+, output) is directly connected to the (+) power supply terminal.

5. Carry out the wiring work after shutting down the power.

If the wiring work is performed with the power turned ON, this may cause electric shock, malfunction, or damage to the auto switch.

6. Do not allow short-circuit of loads.

Otherwise, the protection circuit will be activated and the indicator light will flash.

At the same time, the auto switch will be damaged.

7. Avoid incorrect wiring.

1) If connections are reversed on a 2-wire type auto switch, the auto switch will not be damaged if protected by a protection circuit, but the auto switch will always stay in an ON state.

However, it is still necessary to avoid reversed connections, since the auto switch could be damaged by a load short circuit in this condition.

2) If connections are reversed (power supply line + and power supply line -) on a 3-wire type auto switch, the auto switch will be protected by a protection circuit. However, if the power supply line (+) is connected to the blue wire and the power supply line (-) is connected to the black wire, the auto switch will be damaged.

Operating Environment

1. Never use in an atmosphere of explosive gases, dust.
The structure of auto switches is not intended to prevent explosion. This may lead to explosion hazard.
2. Do not use in an area where a magnetic field is generated.
Auto switches will malfunction or magnets inside cylinders/ actuators will become demagnetized.
3. Do not use in an environment where the auto switch will be continually exposed to water.
Although auto switches satisfy the IEC standard IP67 specifications, do not use in applications continually exposed to water splashing or spray. This may cause improper insulation or malfunction.
4. Do not use in an environment with oil or chemicals.
If auto switches are used in an environment containing coolant, cleaning solvent, various oils, or chemicals even for a short period of time, this may adversely affect the auto switches, resulting in improper insulation, malfunction due to swelling of the potting resin, or hardening of the lead wires.
When using solutions such as cutting oil/grinding oil/cleaning solution, even if there is no problem with a single solution, the workpiece is transported to the next process with the solution from the previous process adhering to it, etc., and multiple solutions may mix and change components, resulting in a short life span.
Depending on the temperature environment and coolant fluid used, water-resistant performance may deteriorate.
5. Do not use in an environment with temperature cycles.
If temperature cycles other than normal temperature changes are applied, this may adversely affect the insides of the auto switches.
6. Avoid accumulation of iron waste or close contact with magnetic substances.
If many iron particles, such as cutting chips or spatters accumulate around a cylinder with the auto switches or an actuator or if a magnetic substance (attracted by a magnet) is put close to a cylinder with the auto switch or an actuator, the magnetic force inside the cylinder or actuator loses, causing the auto switch to malfunction.
7. Do not use in an area where surges are generated.
If there is an equipment unit (electromagnetic lifter, high-frequency induction furnace, motor, or radio, etc.) that generates large surges or electromagnetic waves around cylinders with solid state auto switches or actuators, this may cause the circuit element inside the auto switch to break.
8. Do not use in direct sunlight.
9. Do not mount the product in locations where it is exposed to radiant heat.
10. Take appropriate measures against the lightning surge on the equipment side as the auto switches do not have any lightning surge resistance specified in the CE/UKCA marking.
11. Do not use in environments subject to radiation stress.
It is not designed to withstand radiation, which may cause damage to the malfunction and internal circuit elements of the auto switch.

Maintenance

1. Perform the following maintenance periodically in order to prevent possible danger due to unexpected auto switch malfunction.
 - 1) Secure and tighten auto switch mounting screws.
If screws become loose or the mounting position is dislocated, retighten them after readjusting the mounting position.
 - 2) Confirm that there is no damage to lead wires.
To prevent faulty insulation, replace auto switches or repair lead wires, etc., if damage is discovered.
 - 3) Confirm the detection setting position.
 - Confirm the green light and position of the 2-color display auto switch.
Confirm that the set position stops at the center of the appropriate operating range (green display area).
If the auto switch shows a red LED while in the ON/OFF position, the mounting position is not correct. Re-adjust the auto switch to the optimum position at the center of the operating range.Some cylinders or actuators indicate the individual setting procedures for the auto switch. If so, set the mounting position using the individual setting procedures.
2. Do not use solvents such as benzene, thinner etc. to clean the product.
They could damage the surface of the body and erase the markings on the body. For heavy stains, use a cloth lightly dampened with diluted neutral detergent, then wipe up any residue with a dry cloth.

Model Indication and How to Order

D-M9 **A**

Output type

Symbol	Specification
N	3-wire, NPN
P	3-wire, PNP
B	2-wire

Electric entry

Symbol	Specification
Nil	In line
V	Perpendicular

Lead wire length/
Connector pin assignment

Symbol	Specification
Nil	500 mm (Half strip)
M	1000 mm (Half strip)
L	3000 mm (Half strip)
Z	5000 mm (Half strip)
SAPC	500 mm (M8-3 pin pre-wired)
SBPC	500 mm (M8-4 pin pre-wired)
SDPC	500 mm (M12-4 pin pre-wired)
MAPC	1000 mm (M8-3 pin pre-wired)
MBPC	1000 mm (M8-4 pin pre-wired)
MDPC	1000 mm (M8-3 pin pre-wired)

Summary of Product parts

•D-M9BA/M9NA/M9PA

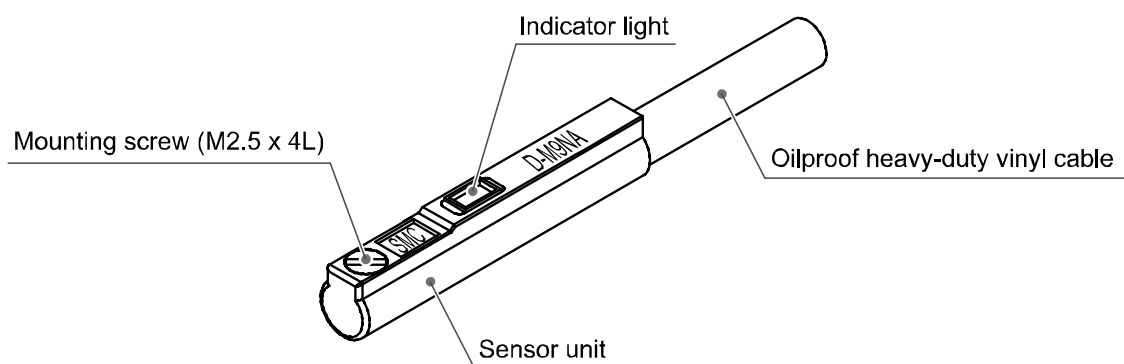

•D-M9BAV/M9NAV/M9PAV

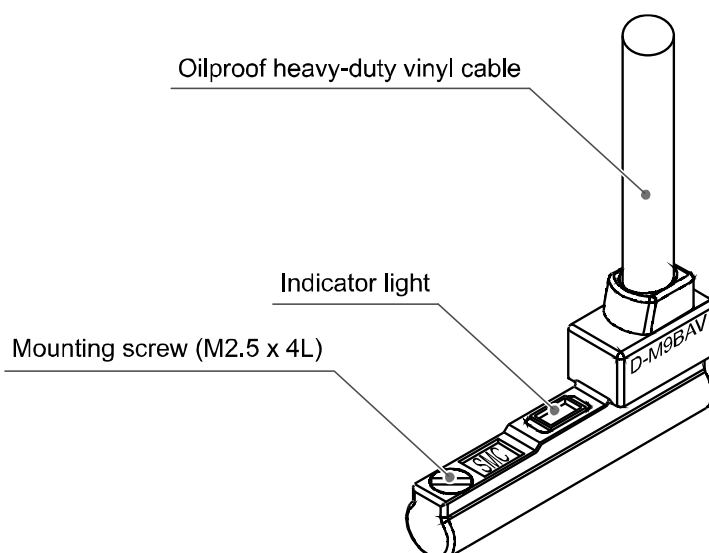

■ Definition and terminology

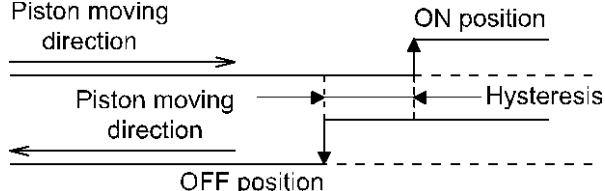
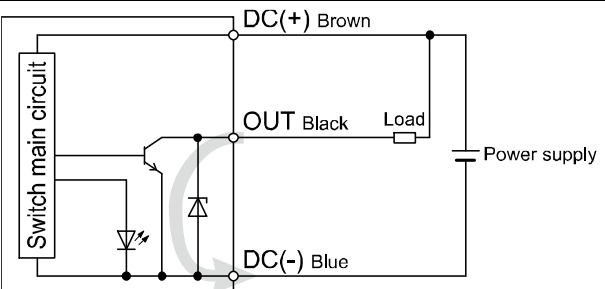
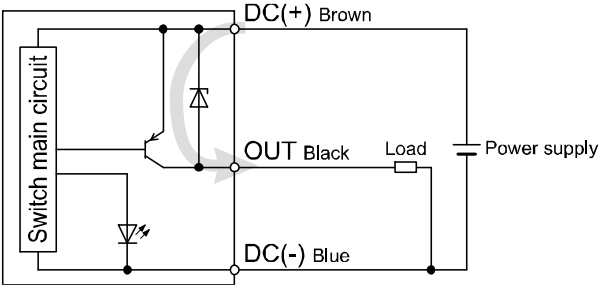
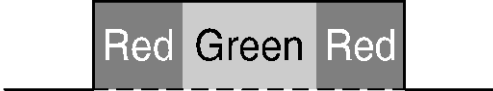
Term	Meaning and definition
Hysteresis	<p>The difference between the points when the Auto switch turns on and off, which is provided to prevent chattering.</p> 
Most sensitive position	<p>The center position of the sensor unit (which gets the strongest reaction of the sensor unit), which means the center position of an operating range as well.</p>
Sequence controller (PLC)	<p>The device to perform sequence control, which performs controlling such as receipt of inputs from the Auto switch along with programming and sending of the output to other machines.</p>
Internal voltage drop	<p>The voltage applied between the COM and signal line when the Auto switch turns on.</p>
Current leakage	<p>The current flowing to the load when the Auto switch turns off.</p>
Load current	<p>The current flowing to the load when the Auto switch turns on.</p>
Solid state auto switch	<p>Auto switch which generates on and off outputs with or without mechanical contact such as a transistor.</p>
Reed auto switch	<p>Auto switch which generates on and off outputs with a mechanical contact.</p>
2-wire auto switch	<p>Auto switch which has only signal line and COM line.</p>
NPN output	<p>Auto switch which sinks current from the signal line when turning on.</p> 
PNP output	<p>Auto switch which sources current from the signal line when turning on.</p> 
2-color indication	<p>A type of indicating methods which lights up the red LED light up when the Auto switch comes to the operating position, and lights up the green LED when the Auto switch comes to the optimum operating position.</p> 

Mounting and Installation

■ Installation

When mounting the Auto switch to actuator it should be done with clamp for actuator.

"How to mount" depends on actuator type and tube I.D. Please refer the actuator catalogue.

When the Auto switch is mounted newly, please prepare the clamp for actuator after confirms that the actuator built in magnet.

• Proper tightening torque

Use a watchmaker driver whose grip diameter is 5 to 6 mm when tightening the mounting screw.

M2.5 mount screw tightening torque range shall be 0.05 to 0.10 N•m (0.5 to 1.0 kgf•cm)

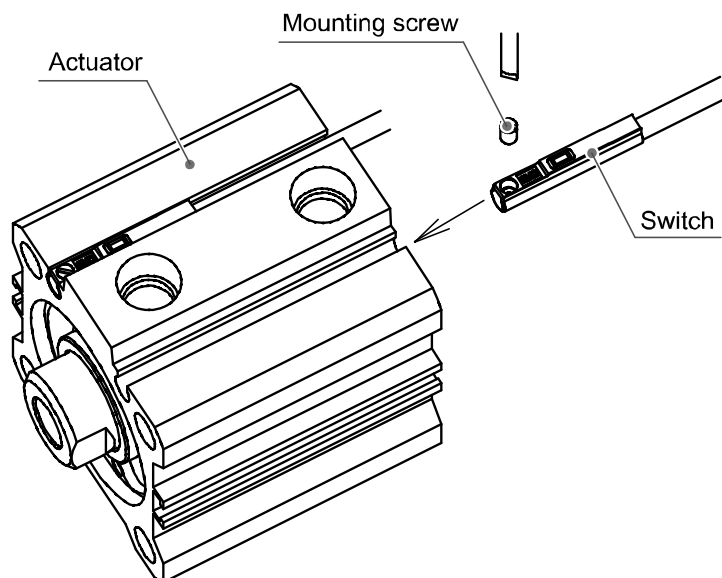

• Setting the detecting position

Set the actuator at the stroke end. Set the switch in the area to where the auto switch red lamp light.

(Detecting actuator end)

Based on A and B dimensions in the actuator catalogue, set the switch.

For actual installation works, perform adjustment with checking the operating conditions of the Auto switch.

Air grippers and rotary actuators have their own setting method. Follow their instructions.

■ Circuit diagram

●D-M9NA(V)

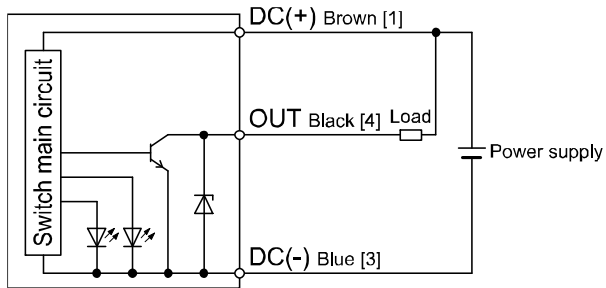

●D-M9PA(V)

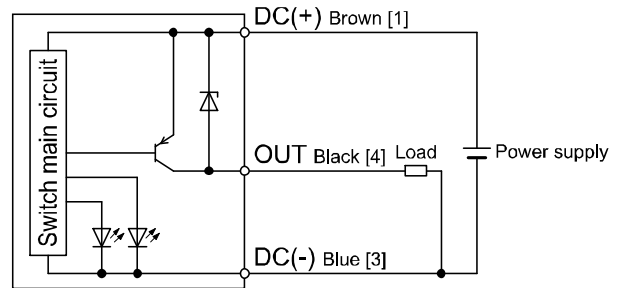

●D-M9BA(V) (Sink input mode)

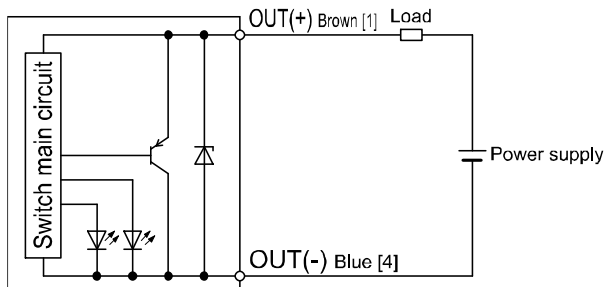

●D-M9BA(V) (Source input mode)

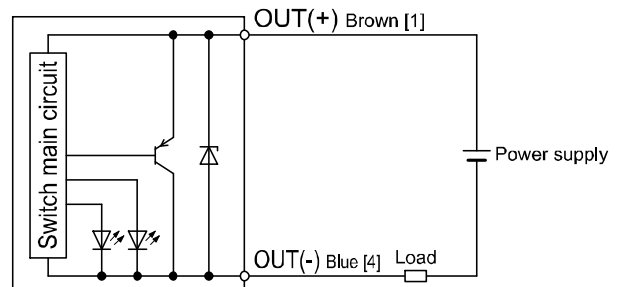

*: The number marked on each lead wire color shows the pin number of pre-wired connector.

Troubleshooting

When the Auto switch falls in operation failure, identify the trouble with the following flow chart.
 A failure of the Auto switch might depend on operating environment (application etc.)
 Contact type: Normally open (normal direction) output

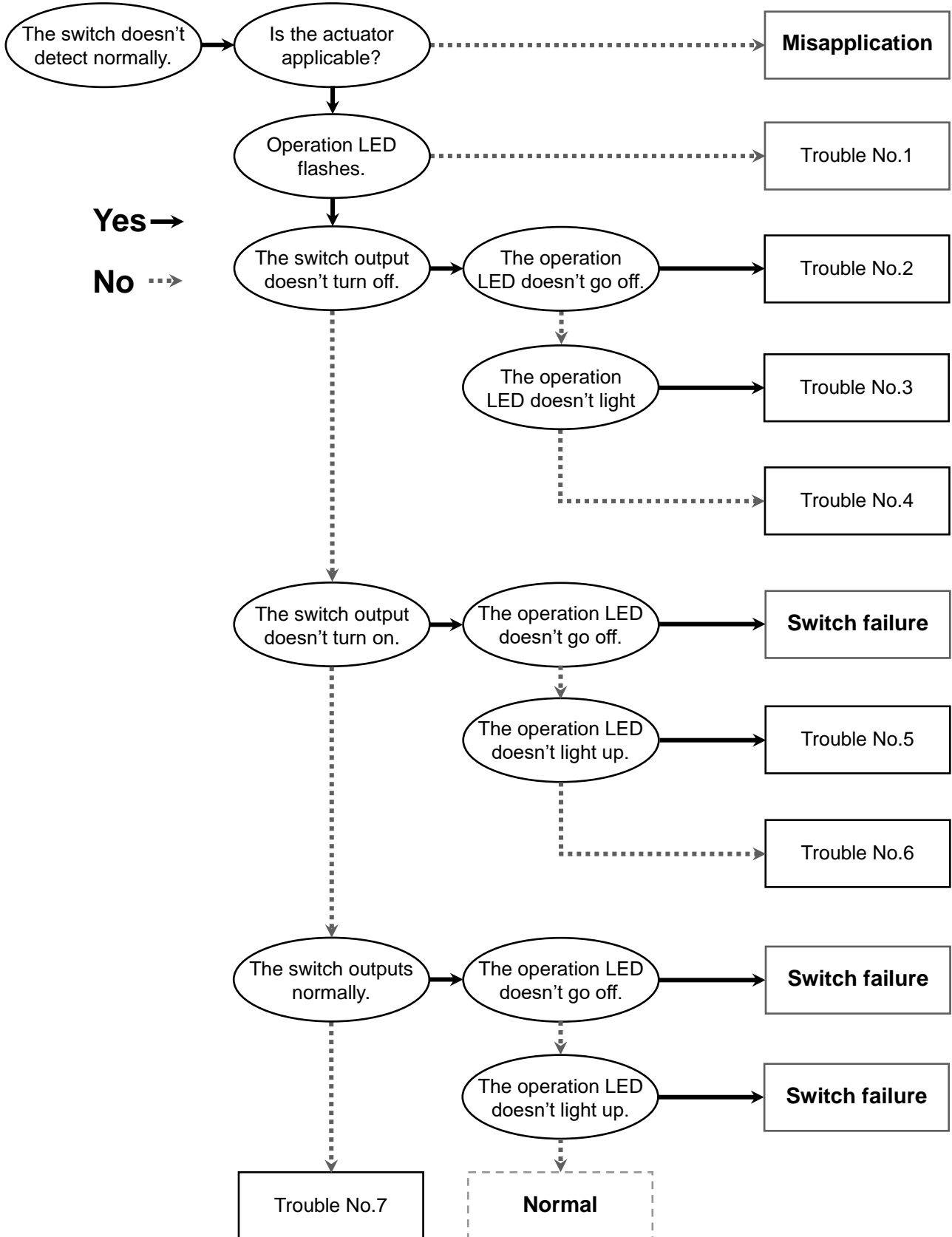

•Cross-reference for troubleshooting

Reference No.	Problem	Possible cause	Investigation method	Countermeasure
1	Output ON and OFF is displayed in turn	Wiring failure	Check that the load is connected.	Correct wiring. (Refer to "Circuit diagram" on page 13.)
		Not match with load specification	Check if load specification satisfy the formula below. Load current ≤ 40 mA	Change to a load which satisfies the formula.
		Lead wire disconnection	Presence of repeated bending stress to one point of the lead wire. (Bend radius/Tensile force to lead wire)	Correct wiring. (Correct tensile force/increase bend radius)
2	Output stays ON Display stays ON	Malfunction due to turbulence magnetic field	Influence of the magnetic field of adjacent cylinder.	Use magnetic shield between cylinders.
		Incorrect setting (mounting) position *: Short stroke	Check if the condition is as below. Switch operation range. > Piston stroke	Displace the switch set position from the operation range center.
3	Output stays ON Display stays OFF	Wiring failure (2-wire type)	Check if the switch wiring connection is reversed (Brown/Blue).	Correct wiring. (Refer to "Circuit diagram" on page 13.)
		Switch failure (3-wire type)		Replace the switch.
4	Output stays ON Display is normal	Not match with load specification (2-wire type)	Check if load specification satisfy the formula below. Load ON voltage > (Switch leak current x n) x Load resistance or load OFF current > (Switch leak current x n) n: Number of switch connected in parallel	Change to 3-wire type or reed Auto switch. Reduce the number of switch connected in parallel.
		Wiring failure (3-wire type)	Check reversed connection of the switch wiring (Black/Blue).	Correct wiring. (Refer to "Circuit diagram" on page 13.)

Reference No.	Problem	Possible cause	Investigation method	Countermeasure
5	Output stays OFF Display stays OFF	Abnormal power source	Check the source voltage. (Zero or very low)	Set the source voltage to specified voltage. (Refer to "Specifications (power voltage and load voltage)" on page 18.)
		Wiring failure	Voltage applied to switch (load voltage).	Correct wiring. (Refer to "Circuit diagram" on page 13.)
		Incorrect setting (mounting) position	Check if detection is made close to the operation range limit.	Correct the position. (Center of operation range)
		Set position displacement	Loose set bracket or set screw.	Fix at the right position with right torque. Tightening torque: 0.05 to 0.10 N·m
		Stop position displacement of the piston	Check if the stroke stop position is Inconsistent.	Stabilize stop position. (Correction of displacement/cushion)
		Decrease of Detected magnetic field (demagnetization)	Presence of magnetic field generating source around the cylinder. (Electric welding machine conductor/ Strong magnet)	Use the shield between magnetic field generating source and cylinder.
			Influence of magnetic field of adjacent cylinder (20 mm or less).	Keeps cylinder away (40 mm or more). Use magnetic shielding.
			Presence of magnetic material (chip) piled up on the cylinder.	Remove piled up magnetic material.
Lead wire disconnected	Presence of repeated bending stress to one point of the lead wire. (Bend radius/Tensile force to lead wire)	Correct wiring. (Correct tensile force/increase bend radius)		
6	Output stays OFF Display is normal	Not match with load specification (2-wire type)	Check if load specification satisfy the formula below. Load ON voltage < Load voltage – (Switch internal voltage drop x n) n: Number of switch connected in serial	Change to 3-wire type or reed Auto switch. Reduce the number of switch connected in serial.
		Wiring failure (Output line) (3-wire type)	Connect condition (connector contact pin / crimp terminal).	Correct wiring. (Re-wiring the connecting part)
		Disconnection of lead wire (black) (3-wire type)	Presence of repeated bending stress to one point of the lead wire. (Bend radius / Tensile force to lead wire)	Correct wiring. (Correct tensile force/increase bend radius)

Reference No.	Problem	Possible cause	Investigation method	Countermeasure
7	Unstable operation (Chattering)	Incorrect setting (mounting) position	Check if detection is made around the limit of operation range.	Correct the position. (center of the operation range.)
		Set position displacement	Loose set bracket or set screw.	Fix at the right position with right torque. Tightening torque: 0.05 to 0.10 N•m
		Wiring failure	Condition of connecting part (connector contact pin/crimp terminal).	Correct wiring. (Re-wiring of connecting part)
		Lead wire disconnection	Presence of repeated bending stress to one point of the lead wire. (Bend radius/Tensile force to lead wire)	Correct wiring. (Correct tensile force/increase bend radius)
		Malfunction due to turbulence magnetic field	Presence of magnetic field generating source around the cylinder. (Cylinder, electric welding machine conductor, motor, magnet etc.)	Use the shield between magnetic field generating source and cylinder. Keep the cylinder away from magnetic field generating source.
	Multiple point operation	Malfunction due to turbulence magnetic field	Influence of the magnetic field of adjacent cylinder.	Use magnetic shield between Cylinders.
	Load does not operate	Detect the intermediate position of the stroke	Check if piston speed satisfy the formula below. Load operation time [s] < Switch operation time [mm] /piston speed [mm/s]	Reduce the piston speed until the formula is satisfied

Specification

■ Specifications

Switch part no.	D-M9NA	D-M9NAV	D-M9PA	D-M9PAV	D-M9BA	D-M9BAV
Lead wire orientation	In line	Perpendicular	In line	Perpendicular	In line	Perpendicular
Wiring	3-wire			2-wire		
Output	NPN		PNP		-	
Applicable load	IC circuit/Relay/PLC			24 VDC Relay/PLC		
Power supply voltage	5/12/24 VDC (4.5 to 28 VDC)			-		
Current consumption	10 mA or less			-		
Load voltage	28 VDC or less		-		24 VDC (10 to 28 VDC)	
Load current	40 mA or less			2.5 to 40 mA		
Internal voltage drop	0.8 V or less at load current of 10 mA (2 V or less at load current of 40 mA)			4 V or less		
Current leakage	100 μ A or less at 24 VDC			0.8 mA or less		
Indication light	Operating position: The red LED lights up. Optimum operating position: The green LED lights up.					
Standard	CE/UKCA marked					

● Oilproof heavy-duty lead wire specifications

Switch part no.	D-M9NA#	D-M9NAV#	D-M9PA#	D-M9PAV#	D-M9BA#	D-M9BAV#
Sheath	Outside diameter (mm)	2.6				
	Wires	3-wire (Brown, Blue, Black)			2-wire (Brown, Blue)	
Insulator	Outside diameter (mm)	0.88				
	Cross section (mm ²)	0.13				
Conductor	Wire diameter (mm)	0.05				
	Minimum bending radius (mm) (Reference value)	17				

■ Dimensions

●D-M9BA/M9NA/M9PA

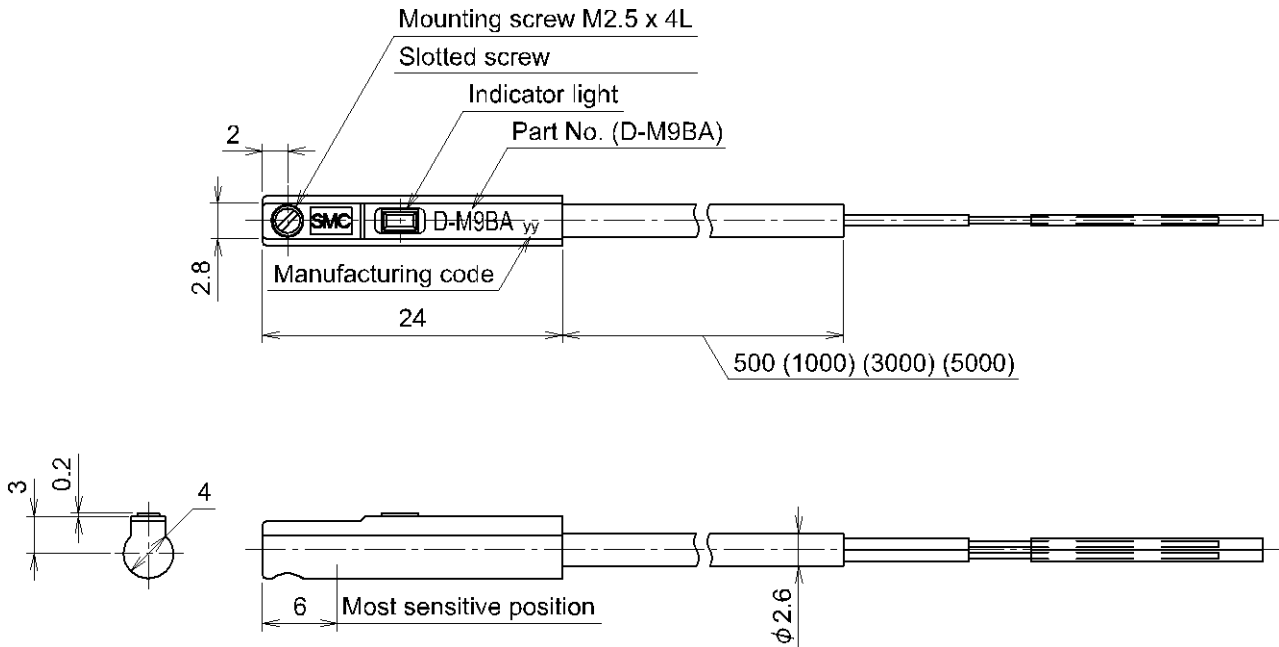

●D-M9BAV/M9NAV/M9PAV

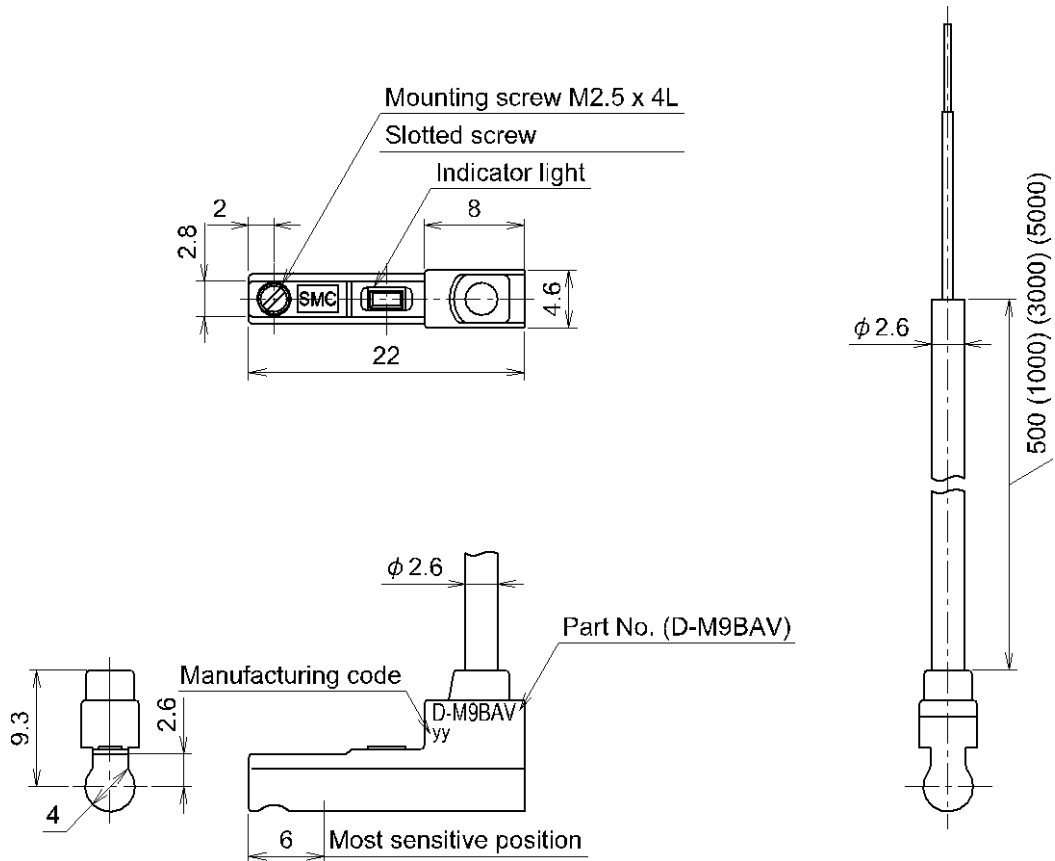

Revision history

A: Modify the contents.
B: Limited warranty and Disclaimer are added.
C: Contents revised in several places.
[August 2016]
D: Contents revised in several places.
[August 2018]
E: Contents revised in several places. [June 2019]
F: Contents revised in several places. [April 2020]
G: Modified errors in text. [October 2020]
H: Contents are added. [July 2022]
I: Revised content in accordance with Safety
Instructions. [April 2024]

SMC Corporation

Tel: + 81 3 5207 8249 Fax: +81 3 5298 5362
URL <https://www.smcworld.com>

Note: Specifications are subject to change without prior notice and any obligation on the part of the manufacturer.
© SMC Corporation All Rights Reserved

