



# Operation Manual

PRODUCT NAME

*Low-Speed Rotary Actuator*

MODEL / Series / Product Number

*CRQ2XB\*10 to 40*

**SMC Corporation**

# Contents

Safety Instructions	2
<b>1. Outline</b>	<b>18</b>
1-1 Specification	18
1-2 Effective torque	19
1-3 Rotation range	19
<b>2. Internal structure and parts description</b>	<b>20</b>
2-1 Size 10,15	20
2-2 Size 20,30,40	21
<b>3. Basic circuit of the rotary actuator</b>	<b>22</b>
3-1 Circuit structure	22
3-2 Recommended equipment	22
<b>4. Mounting</b>	<b>23</b>
4-1 Restriction of the load to axis	23
4-2 Operation of axis fitting referring	23
4-3 Flange application	24
4-4 Piping and operating direction	24
4-5 Operating air	24
<b>5. Setting rotation time</b>	<b>25</b>
5-1 Inertia moment	25
5-2 Kinetic energy	27
<b>6. Rotary actuator with Autoswitch</b>	<b>28</b>
6-1 Autoswitch specification	28
6-2 Autoswitch installation	29
6-3 Autoswitch set position	30
6-4 Internal structure and operation principle	30
<b>7. Maintenance and Inspection</b>	<b>31</b>
7-1 Periodic inspection	31
7-2 Disassemble and reassemble	31
7-2-1 Caution of disassemble	31
7-2-2 Disassembling procedure	32
7-2-3 Assemble procedure	33
7-3 Troubleshooting	37

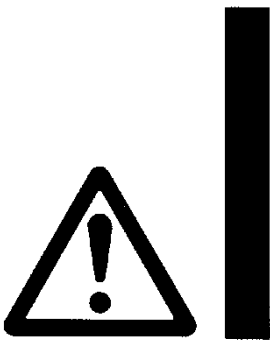

# Safety Instructions

These safety instructions are intended to prevent hazardous situations and/or equipment damage. These instructions indicate the level of potential hazard with the labels of “**Caution**,” “**Warning**” or “**Danger**.” They are all important notes for safety and must be followed in addition to International Standards (ISO/IEC)<sup>1)</sup>, and other safety regulations.

\*1) ISO 4414: Pneumatic fluid power - General rules and safety requirements for systems and their components  
ISO 4413: Hydraulic fluid power - General rules and safety requirements for systems and their components  
IEC 60204-1: Safety of machinery - Electrical equipment of machines - Part 1: General requirements  
ISO 10218-1: Robots and robotic devices - Safety requirements for industrial robots - Part 1: Robots  
etc.

	<b>Danger</b>	<b>Danger</b> indicates a hazard with a high level of risk which, if not avoided, will result in death or serious injury.
	<b>Warning</b>	<b>Warning</b> indicates a hazard with a medium level of risk which, if not avoided, could result in death or serious injury.
	<b>Caution</b>	<b>Caution</b> indicates a hazard with a low level of risk which, if not avoided, could result in minor or moderate injury.

## **Warning**

### **1. The compatibility of the product is the responsibility of the person who designs the equipment or decides its specifications.**

Since the product specified here is used under various operating conditions, its compatibility with specific equipment must be decided by the person who designs the equipment or decides its specifications based on necessary analysis and test results. The expected performance and safety assurance of the equipment will be the responsibility of the person who has determined its compatibility with the product. This person should also continuously review all specifications of the product referring to its latest catalog information, with a view to giving due consideration to any possibility of equipment failure when configuring the equipment.

### **2. Only personnel with appropriate training should operate machinery and equipment.**

The product specified here may become unsafe if handled incorrectly. The assembly, operation and maintenance of machines or equipment including our products must be performed by an operator who is appropriately trained and experienced.

### **3. Do not service or attempt to remove product and machinery/equipment until safety is confirmed.**

1. The inspection and maintenance of machinery/equipment should only be performed after measures to prevent falling or runaway of the driven objects have been confirmed.
2. When the product is to be removed, confirm that the safety measures as mentioned above are implemented and the power from any appropriate source is cut, and read and understand the specific product precautions of all relevant products carefully.
3. Before machinery/equipment is restarted, take measures to prevent unexpected operation and malfunction.

### **4. Our products cannot be used beyond their specifications. Our products are not developed, designed, and manufactured to be used under the following conditions or environments. Use under such conditions or environments is not covered.**

1. Conditions and environments outside of the given specifications, or use outdoors or in a place exposed to direct sunlight.
2. Use for nuclear power, railways, aviation, space equipment, ships, vehicles, military application, equipment affecting human life, body, and property, fuel equipment, entertainment equipment, emergency shut-off circuits, press clutches, brake circuits, safety equipment, etc., and use for applications that do not conform to standard specifications such as catalogs and operation manuals.
3. Use for interlock circuits, except for use with double interlock such as installing a mechanical protection function in case of failure. Please periodically inspect the product to confirm that the product is operating properly.



# Safety Instructions

## Caution

**We develop, design, and manufacture our products to be used for automatic control equipment, and provide them for peaceful use in manufacturing industries.**

**Use in non-manufacturing industries is not covered.**

Products we manufacture and sell cannot be used for the purpose of transactions or certification specified in the Measurement Act.

The new Measurement Act prohibits use of any unit other than SI units in Japan.

## Limited warranty and Disclaimer/Compliance Requirements

The product used is subject to the following “Limited warranty and Disclaimer” and “Compliance Requirements”. Read and accept them before using the product.

### Limited warranty and Disclaimer

1. The warranty period of the product is 1 year in service or 1.5 years after the product is delivered, whichever is first.\*2)

Also, the product may have specified durability, running distance or replacement parts. Please consult your nearest sales branch.

2. For any failure or damage reported within the warranty period which is clearly our responsibility, a replacement product or necessary parts will be provided.

This limited warranty applies only to our product independently, and not to any other damage incurred due to the failure of the product.

3. Prior to using SMC products, please read and understand the warranty terms and disclaimers noted in the specified catalog for the particular products.

**\*2) Vacuum pads are excluded from this 1 year warranty.**

A vacuum pad is a consumable part, so it is warranted for a year after it is delivered.

Also, even within the warranty period, the wear of a product due to the use of the vacuum pad or failure due to the deterioration of rubber material are not covered by the limited warranty

### Compliance Requirements

1. The use of SMC products with production equipment for the manufacture of weapons of mass destruction (WMD) or any other weapon is strictly prohibited.

2. The exports of SMC products or technology from one country to another are governed by the relevant security laws and regulations of the countries involved in the transaction. Prior to the shipment of a SMC product to another country, assure that all local rules governing that export are known and followed.

## **Warning**

**1. Confirm the specifications.**

Products represented in this catalog are designed only for use in compressed air systems.

Do not operate at pressures or temperatures, etc., beyond the range of specifications, as this can cause damage or malfunction. (Refer to the specifications.)

We do not guarantee against any damage if the product is used outside of the specification range.

**2. If the operation involves load fluctuations, ascending/descending movements, or changes in friction resistance, make sure to provide safety measures.**

Operating speed will increase, and bodily injury may occur, or damage to the machinery itself may occur.

**3. If there is a chance that the product will pose a hazard to humans, install a protective cover.**

If the moving portion of the product will pose a hazard to humans or will damage machinery or equipment, provide a construction that prevents direct contact with those areas.

**4. Be certain that the secured portions will not loosen.**

Be certain to adopt a reliable connecting method if the rotary actuator is used very frequently or if it is used in a location that is exposed to a large amount of vibrations.

**5. There may be cases in which a speed reduction circuit or a shock absorber is required.**

If the driven object moves at high speeds or is heavy, it will be unfeasible for only the rotary actuator's cushion to absorb the shock. Therefore, provide a speed-reduction circuit to reduce the rotary actuator's speed before the thrust is applied to the cushion, or an external shock absorber to dampen the shock. If these countermeasures are taken, make sure to take the rigidity of the mechanical equipment into consideration.

**6. Consider the possibility of a reduction in the circuit air pressure caused by a power failure.**

When a rotary actuator is used as clamping mechanism, there is a danger of workpiece dropping if there is a decrease in clamping force, due to a drop in circuit pressure caused by a power failure. Therefore, safety equipment should be installed to prevent damage to machinery and bodily injury.

**7. Consider the possibility of power source related malfunctions that could occur.**

For the machinery equipment that rely on power sources such as compressed air, electricity, or hydraulic pressure, adopt countermeasure to prevent the equipment from causing a hazard to humans or damage to the machinery and equipment in the event of malfunction.

**8. If a speed controller is provided in the exhaust restrictor, implement a safety design taking the residual pressure into consideration.**

If air pressure is applied to the air supply side without residual pressure in the exhaust side, the rotary table will operate at abnormally high speeds, which could pose a hazard to humans and damage the machinery and equipment.

**9. Consider the behavior of the rotary actuator in the event of an emergency stop.**

Devise a safe system so that if a person engages the emergency stop, or if a safety device is tripped during a system malfunction such as a power failure, the movement of the rotary actuator will not cause a hazard to humans or damage the equipment.

**10. Consider the action of the rotary actuator when restarting after an emergency stop.**

Devise a safe design so that the restarting of the rotary actuator will not pose a hazard to humans or damage the equipment. Install manually controlled equipment for safety when the rotary actuator has to be reset to the starting position.

**11. Do not use the product as a shock absorber.**

If an abnormal pressure or air leakage occurs, the rotary actuator's speed reduction capability could become severely affected, which could pose a hazard to humans and damage the machinery and equipment.

**12. Select a speed within the product's allowable energy value.**

If the product's kinetic energy of the load exceeds the allowable value, it could damage the product, and cause a hazard to humans and damage the machinery and equipment.

**13. Provide a shock absorber if the kinetic energy that is applied to the product exceeds the allowable value.**

If the product's kinetic energy exceeds the allowable value, it could damage the product, and cause a hazard to humans and damage the machinery or equipment.

**14. Do not stop or hold the product at midpoint by keeping air pressure in the product. (Air balancers etc.)**

For a product lacking an external stopping mechanism, if the directional control valve is closed to keep the air pressure in the product, in an attempt to stop the product at midpoint, it might not be possible to maintain that stopped position due to an air leakage. As a result, it could pose a hazard to humans and cause damage to machinery and/or equipment.

**15. Give consideration to the decline in strength caused by changes in the shaft shape.**

Some shaft types, such as simple specials, may have shapes and dimensions that result in decreased strength when compared with standard models. Consider this carefully when using.

**16. Do not use two or more rotary actuator with the aim of synchronized movement.**

One of the rotary actuator may bear the load of operation, making synchronized movement impossible, and possibly leading to deformation of the equipment.

**17. Do not use in a location where adverse effect could be occurred by the oozing of the lubricant to the exterior.**

The lubricant coating the interior of the product may leak to the outside of the product from connecting parts of the rotary body, cover, etc.

**18. Do not disassemble the product or make any modifications, including additional machining.**

This may cause human injury and/or an accident.

**19. Refer to the Auto Switches Precautions for using with an auto switch.**

 **Caution**

**1. Do not use below the speed adjustment range specified for the product.**

If the product is used below the specified speed adjustment range, it could cause the product to stick, slip, or the movement to stop.

**2. Do not apply an external torque to the product that exceeds the rated output.**

If an external force that exceeds the product's rated output is applied to the product, it could damage the product.

**3. If it is necessary to provide repeatability of the rotation angle, directly stop the load externally.**

Even with a product that is equipped with an angle adjuster, there are times when the initial rotation angle could change.

**4. Do not use under hydraulic pressure.**

The product will be damaged if it is used by applying hydraulic pressure.

**5. Do not use in a places where there are many temperature fluctuations.**

**When using in lower temperature applications, use caution so that frost does not occur inside the cylinder or the piston rod.**

Operation may be unstable.

**6. Adjust the speed control in the environment in which it will be used in.**

Speed adjustment may be changed if the environment is different.

## Mounting

# **Warning**

### 1. **Operation manual**

Install the product and operate it only after reading the operation manual carefully and understanding its contents. Also, keep the manual in a location where it can be referred to as necessary.

### 2. **Ensure sufficient space for maintenance activities.**

When installing the products, allow access for maintenance.

### 3. **Tighten threads with the proper tightening torque.**

When installing the products, follow the listed torque specifications.

### 4. **Before adjusting the angle by supplying air pressure, take appropriate measures to prevent the equipment from rotating unnecessarily.**

When an adjustment is performed under air pressure, the equipment could rotate and fall during the adjustment, depending on the mounted posture of the equipment. As a result, it could pose a hazard to humans and damage the machinery and equipment.

### 5. **Do not loosen the angle adjustment screw beyond the allowable adjustment range.**

The angle adjustment screw could fall out if it is loosened beyond its allowable adjustment range, which could pose a hazard to humans and damage the machinery and equipment.

### 6. **Do not place a magnetic object near the product.**

The auto switch is a magnetic sensing type. If a magnetic object is placed close to it, the rotary actuator could operate suddenly, which could pose a hazard to humans and damage the machinery and equipment.

### 7. **Do not perform additional machining to the product.**

Additional machining to the product can result in insufficient strength and cause damage to the product. This can lead to possible human injury and damage to the surrounding equipment.

### 8. **Do not enlarge the fixed throttle by modifying the pipe connectors.**

If the hole diameter is enlarged, the product's rotation speed will increase, causing the shock force to increase and damage to the product. As a result, it could pose a hazard to humans and damage the machinery and equipment.

### 9. **If shaft couplings are used, use those with angular freedom.**

If shaft couplings that lack angular freedom are used, they could scrape due to eccentricity, leading to equipment malfunction and product damage. As a result, it could pose a hazard to humans and damage the machinery and equipment.

### 10. **Do not apply to the shaft a load that exceeds the values given in a catalog.**

If a load that exceeds the allowable value is applied to the product, it could lead to equipment malfunction, a hazard to humans and damage to the machinery and equipment. Provided that a dynamic load is not generated, a load that is within the allowable radial / thrust load can be applied. However, applications in which the load is applied directly to the shaft should be avoided whenever possible. The methods such as those described below are recommended to prevent the load from being applied directly to the shaft in order to ensure a proper operating condition.

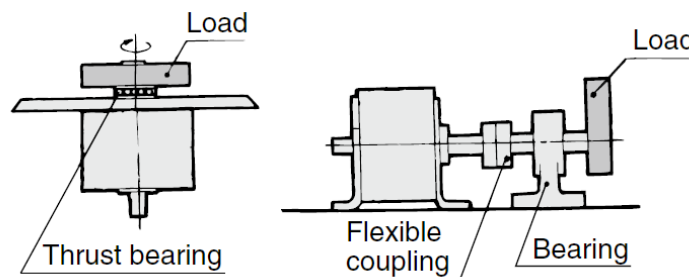

### 11. **Do not use springs, etc., to add force in the rotational movement direction.**

When rotational force from an external spring, etc., acts and generates negative pressure on the product's interior, breakage of the internal seal or acceleration of abrasion may occur.

## 12. Place an external stopper in a position that is away from the rotating shaft.

If the stopper is placed near the rotating shaft, the torque that is generated by the product itself will cause the reaction force which is directed to the stopper to be redirected and applied to the rotating shaft. This will lead to the breakage of the rotating shaft and bearing. As a result, it could pose a hazard to humans and damage the machinery and equipment.

### Precautions when Using External Stoppers

- Be sure to install external stoppers in the proper places. Installation in the wrong place can result in equipment breakage, which could damage other equipment or cause human injury.

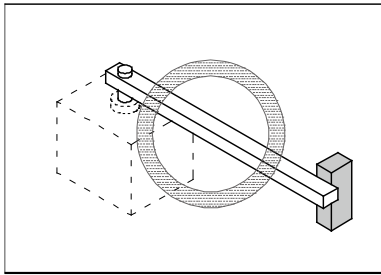

Install the stopper at a sufficient distance from the rotating shaft.

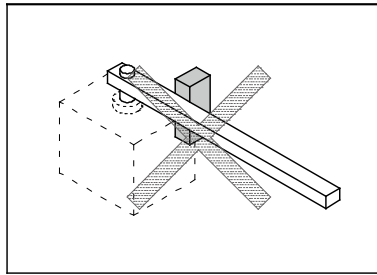

The external stopper becomes a fulcrum, resulting in the load's inertia force being applied to the table as a bending moment.

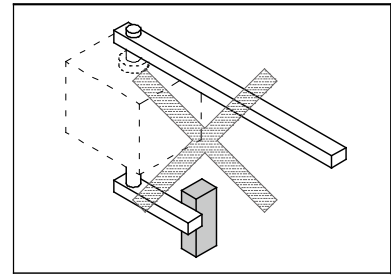

If an external stopper is installed on the opposite side of the load, the inertia force generated by the load is applied directly to the table.

- Install external stoppers within the range of the rotating angle. Installing an external stopper at the maximum rotation angle may result in an inability to fully absorb the kinetic energy generated, and damage to equipment may occur.
- Angle adjustment is available for this product. When using an external stopper, set in a position so that that the adjusting bolt does not collide into the piston.

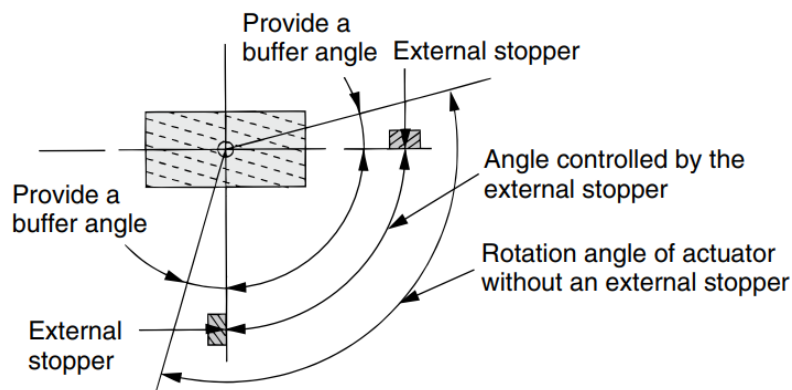

### Precautions when Converting Rotational Motion to Linear Motion

When using a link mechanism, etc., to convert rotational motion to linear motion, and determining the operation end using the stopper on the linear motion end (see below), a small value for  $\theta$  at the operation end may result in the torque of the rotary actuator causing excessive radial load to act on the output axle, and equipment breakage may occur.

Install a stopper on the rotation motion side, or increase the value of  $\theta$  at the operation end, to make sure the load generated does not exceed the allowable value for the product.

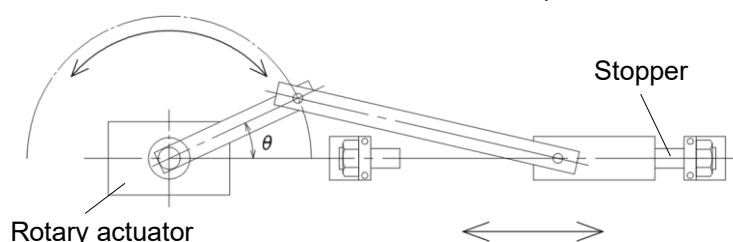

## Caution

1. **Do not use organic solvent to wipe the area of the name plate that shows the model.**  
It will erase what is indicated on the name plate.
2. **Do not hit the rotating shaft by securing the body or hit the body by securing the rotating shaft.**  
These actions could cause the shaft to bend or damage the bearing. When a load must be coupled to the rotating shaft, secure the rotating shaft.
3. **Do not place your foot directly on the shaft or on the equipment that is coupled to the shaft.**  
Placing one's weight directly onto the rotating shaft could cause the rotating shaft or the bearing to become damaged.
4. **If a product is equipped with an angle adjustment function, use it within the specified adjustment range.**  
If the product is used outside the specified adjustment range, it could lead to equipment malfunction or product damage. Refer to the product specifications for details on the adjustment range of the products.
5. **A product with an angle adjustment screw is temporarily secured at an arbitrary position near the rotation end. Before using the product, readjust it to the desired angle and tighten the screw firmly.**

### Piping

## Caution

1. **Refer to the Fittings and Tubing Precautions (Best Automation No.9) for handling one touch fittings.**
2. **Preparation before piping**  
Before piping is connected, it should be thoroughly blown out with air (flushing) or washed to remove chips, cutting oil and other debris from inside the pipe.
3. **Wrapping of pipe tape**  
When screwing piping or fittings into ports, ensure that chips from the pipe threads or sealing material do not enter the piping. Also, if tape is used, leave 1.5 to 2 thread ridges exposed at the end of the threads.

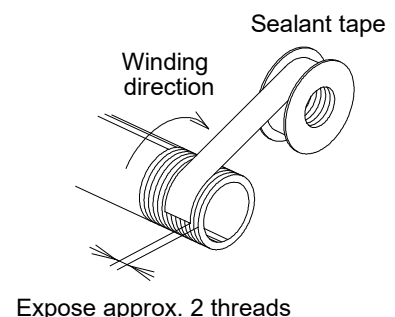

### Speed and Cushion Adjustment

## Warning

1. **To make a speed adjustment, gradually adjust starting from the low speed end.**  
If the speed adjustment is performed from the high speed end, it could damage the product. As a result, it could pose a hazard to humans and damage the machinery and equipment.

## Lubrication

### **Warning**

1. **This product should be used without lubrication. Although it will operate even if it is lubricated, it could lead to sticking or slipping.**

## Air Supply

### **Warning**

1. **Type of fluids**  
Use compressed air.
2. **When there is a large amount of moisture**  
Compressed air containing a large amount of moisture can cause malfunction of pneumatic equipment. An air dryer or water separator should be installed upstream from filters.
3. **Drain flushing**  
If condensation in the drain bowl is not emptied on a regular basis, the bowl will overflow and allow the condensation to enter the compressed air lines. This may cause malfunction of pneumatic equipment. If the drain bowl is difficult to check and remove, installation of a drain bowl with an auto drain option is recommended.
4. **Use clean air.**  
Do not use compressed air that contains chemicals, synthetic oils including organic solvents, salt or corrosive gases, etc., as it can cause damage or malfunction.

### **Caution**

1. **When low dew point air is used as the fluid, degradation of the lubrication properties inside the equipment may occur, resulting in reduced reliability (or reduced service life) of the equipment.**  
Please consider using low dew point products such as 25A-series.
2. **Install an air filter.**  
Install an air filter upstream near the valve. Select an air filter with a filtration size of 5µm or smaller.
3. **Take measures to ensure air quality, such as by installing an aftercooler, air dryer, or water separator.**  
Compressed air that contains a large amount of moisture can cause malfunction of pneumatic equipment such as rotary actuator. Therefore, take appropriate measures to ensure air quality, such as by providing an aftercooler, air dryer, or water separator.
4. **Ensure that the fluid and ambient temperature are within the specified range.**  
If the fluid temperature is 5°C or less, the moisture in the circuit could freeze, causing damage to the seals and equipment malfunction. Therefore, take appropriate measures to prevent freezing.

## Operating Environment

### **Warning**

1. **Do not use in an atmosphere having corrosive gases, chemicals, sea water, water, steam, or where there is direct contact with any of these.**

Refer to the construction for information on the rotary actuator material.

2. **Do not expose the product to direct sunlight for an extended period of time.**
3. **Do not use in a place subject to heavy vibration and/or shock.**
4. **Do not mount the product in locations where it is exposed to radiant heat.**
5. **Do not use in dusty locations or where water oil, etc., splash on the equipment.**

## Maintenance

### **Warning**

1. **Perform maintenance inspection according to the procedures indicated in the operation manual.**

If handled improperly, malfunction and damage of machinery or equipment may occur.

2. **Maintenance work**

If handled improperly, compressed air can be dangerous. Assembly, handling, repair and element replacement of pneumatic systems should be performed by a knowledgeable and experienced person.

3. **Drain flushing**

Remove drainage from air filters regularly.

4. **Removal of equipment, and supply/exhaust of compressed air**

When components are removed, first confirm that measures are in place to prevent workpieces from dropping, run-away equipment, etc. Then, cut off the supply pressure and electric power, and exhaust all compressed air from the system using the residual pressure release function.

When machinery is restarted, proceed with caution after confirming that appropriate measures are in place to prevent cylinders from sudden movement.

### **Caution**

1. **For lubrication, use the designated grease for each specific product.**

The use of a non-designated lubricant could damage the seals.

## Auto Switches Precautions

### Design / Selection

## **Warning**

### 1. **Confirm the specifications.**

If the product is used with excess load applied or beyond the specification range, this may cause the product to break or malfunction. We do not guarantee against any damage if the product is used outside of the specification range.

### 2. **Cautions for use in an interlock circuit.**

When an auto switch is used for an interlock signal requiring high reliability, devise a double interlock system to avoid trouble by providing a mechanical protection function, or by also using another switch (sensor) together with the auto switch.

Also, perform regular maintenance and confirm proper operation.

### 3. **Do not attempt to disassemble, modify (including exchanging the printed circuit boards), or repair the product.**

An injury or failure can result.

## **Caution**

### 1. **Pay attention to the length of time that a switch is ON at an intermediate stroke position.**

When an auto switch is placed at an intermediate position of the stroke and a load is driven, at the time the piston passes the auto switch will operate, but if the speed is too great the operating time will be shortened and the load may not operate properly.

The maximum piston speed is:

$$V(\text{mm/s}) = \frac{\text{Auto switch operating range (mm)}}{\text{Load applied time (ms)}} \times 1000$$

### 2. **Take precautions when multiple rotary actuators are used close together.**

When multiple auto switch rotary actuators are used in close proximity, magnetic field interference may cause the auto switches to malfunction. Maintain a minimum cylinder separation of 40 mm. (When the allowable interval is specified for each cylinder series, use the indicated value.)

The auto switches may malfunction due to interference from the magnetic fields.

Use of a magnetic screen plate (MU-S025) or commercially available magnetic screen tape can reduce the interference of magnetic force.

### 3. **Ensure sufficient clearance for maintenance activities.**

When designing an application, be certain to allow sufficient clearance for maintenance.

### 4. **Do not mount rotary actuator with the auto switch on a footing.**

If work personnel gets on or puts the work personnel's foot on the footing accidentally, an excessive load is applied to the rotary actuator, causing the rotary table to break.

### 5. **Design the circuit so that any back-flow current does not flow in if a short-circuit trouble occurs or forced operation is performed to check the operation.**

If a back-flow current occurs, this may cause the switch to malfunction or break.

### 6. **When multiple auto switches are required.**

"n" indicates the number of auto switches which can be physically mounted on the rotary actuators. Detection intervals depends on the auto switch mounting structure and set position, therefore some required interval and set positions may not be available.

### 7. **Limitations on detectable position**

There are positions or surfaces (bottom surface of the foot bracket, etc.) where the auto switch cannot be mounted due to the physical interference depending on the rotary actuator mounting status or mounting bracket. Select an appropriate auto switch setting position where the auto switch does not interfere with the rotary actuator mounting bracket (trunnion or reinforcing ring) after checking it sufficiently.

**8. Provide enough space for the lead wire.**

Applying stress to the lead wire and auto switch body connection part increases the risk of disconnection. Provide a space of at least the min. bending radius from the lead wire and auto switch body connection part.

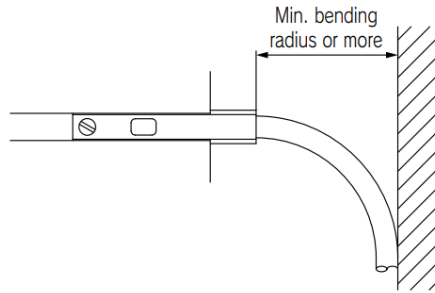

**9. Keep wiring as short as possible.**

<Reed>

As the length of the wiring to a load gets longer, the rush current at switching ON becomes greater, and this may shorten the product's life. (The switch will stay ON all the time.)

- 1) Use a contact protection box when the wire length is 5m or longer.
- 2) Even if an auto switch has a built-in contact protection circuit, when the wiring is more than 30 m long, it is not able to adequately absorb the rush current and its life may be reduced.

<Solid state>

Be sure to use a wire length 100m or less.

When the wire length is long, we recommend the ferrite core should be attached to the both ends of the cable to prevent excess noise. A contact protection box is not necessary for solid state switches due to the nature of this product construction.

**10. Do not use a load that generates surge voltage.**

<Reed>

If a surge voltage is generated, the discharge occurs at the contact, possibly resulting in the shortening of product life.

If driving a load such as a relay that generates a surge voltage, use an auto switch with built-in contact protection circuit or use a contact protection box.

<Solid state>

If driving a load such as a relay that generates a surge voltage, use a built-in surge absorbing element type device.

**11. Pay attention to the internal voltage drop of the auto switch.**

<Reed>

- 1) Auto switch with an indicator light

- If auto switches are connected in series as shown below, take note that there will be a large voltage drop because of internal resistance in the light emitting diodes. (Refer to the internal voltage drop in the auto switch specifications.)

[The voltage drop will be "n" times larger when "n" auto switches are connected.]

Even though an auto switch operates normally, the load may not operate.

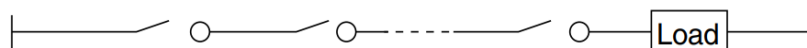

- In the same way, when operating under a specified voltage, although an auto switch may operate normally, the load may not operate. Therefore, the formula below should be satisfied after confirming the minimum operating voltage of the load.

$$\text{Supply voltage} - \text{Internal voltage drop of auto switch} > \text{Minimum operating voltage of load}$$

- 2) If the internal resistance of a light emitting diode causes a problem, select an auto switch without an indicator light.

#### <Solid state / 2-wire type>

Generally, the internal voltage drop of the solid state auto switch is larger than that of the reed auto switch. When the auto switches ("n" pcs.) are connected in series, the voltage drop is multiplied by "n". In this case, the auto switches operate correctly, but the loads may not operate. Additionally, note that the 12 VDC relay does not apply to the auto switch.

### 12. Pay attention to leakage current.

#### <2-wire type>

Current (leakage current) flows to the load to operate the internal circuit even when in the OFF state.

$$\text{Operating current of load (OFF condition)} > \text{Leakage current}$$

If the criteria given in the above formula are not met, it will not reset correctly (stays ON). Use a 3-wire switch if this specification will not be satisfied.

Moreover, leakage current flow to the load will be "n" times larger when "n" auto switches are connected in parallel.

### 13. Output operation of the solid state auto switch is not stable for 50 [ms] after powered ON.

In the output operation immediately after powered ON or AND connection operation, the input device (PCL or relay, etc.) may judge the ON position as OFF output or the OFF position as ON output. So, please make the setting on the equipment so that the input judgement signal is set disabled for 50 [ms] immediately after powered ON or AND connection. When using SMC's AHC system (Auto Hand Changing System) Series MA, please also make this setting.

## Mounting / Adjustment

### **Warning**

#### 1. Do not drop or bump.

Do not drop, bump or apply excessive impacts ( $300\text{m/s}^2$  or more for reed auto switches and  $1000\text{m/s}^2$  or more for solid state auto switches) while handling. Although the body of the auto switch may not be damaged, the inside of the auto switch could be damaged and cause malfunction.

#### 2. Observe the proper tightening torque for mounting an auto switch.

When an auto switch is tightened beyond the range of tightening torque, auto switch mounting screws, auto switch mounting brackets or auto switch may be damaged.

On the other hand, tightening below the range of tightening torque may allow the auto switch to slip out of position.

#### 3. Do not carry a rotary actuator by the auto switch lead wires.

This may cause disconnection of the lead wire or the internal element to break.

#### 4. Do not use screws other than the set screws installed on the auto switch body to secure the auto switch.

If using other screws, auto switch may be damaged.

## 5. Mount an auto switch at the center of the operating range.

In the case of 2-color display auto switch, mount it at the center of the green LED illuminating range. Adjust the mounting position of the auto switch so that the piston stops at the center of the operating range. (The mounting position shown in the catalog indicates the optimum position at stroke end.) If mounted at the end of the operating range (around the borderline of ON and OFF), operation will be unstable depending of the operating environment. Also there are some rotary actuators with individual setting methods for auto switches. If so, mount it in accordance with the indicated method.

**Even if 2-color indication solid state auto switches are fixed at a proper operating range (the green light lights up), the operation may become unstable depending on the installation environment or magnetic field disturbance.**

(Magnetic body, external magnetic field, proximal installation of rotary actuators with built-in magnet and actuators, temperature change, other factors for magnetic force fluctuation during operation, etc.)

## 6. Check the actual actuation status and adjust the auto switch mounting position.

According to the installation environment, the rotary actuator may not operate even at its proper mounting position. Even when setting at a midpoint of the stroke, check the actuation status and make the adjustment in the same manner.

## 7. Be very careful when handling the auto switch mounting band, as it has a thin structure.

### Wiring

## **Warning**

### 1. Confirm proper insulation of wiring.

If there is any improper insulation (mixed contact with other circuit, grounding fault, or improper insulation between terminals, etc.) in the wiring, an over-current flows in, causing the auto switch to break.

### 2. Wire separately from power lines of high voltage lines, avoiding parallel wiring of wiring in the same conduit with these lines.

If an inrush current is generated, the noise may cause the auto switch to malfunction.

### 3. Be certain to connect the load before power is applied.

<2-wire type>

If the power is turned ON when an auto switch is not connected to a load, the auto switch will be instantly damaged because of excess current (short circuit).

It is the same as when the 2-wire brown lead wire (+, output) is directly connected to the (+) power supply terminal.

### 4. Carry out the wiring work after shutting down the power.

If the wiring work is performed with the power turned ON, this may cause electric shock, malfunction, or damage to the auto switch.

## 5. Avoid repeatedly bending or stretching lead wires.

Broken lead wires will result from repeatedly applying bending stress or stretching force to the lead wires. Stress and tensile force applied to the connection between the lead wire and auto switch increases the possibility of disconnection.

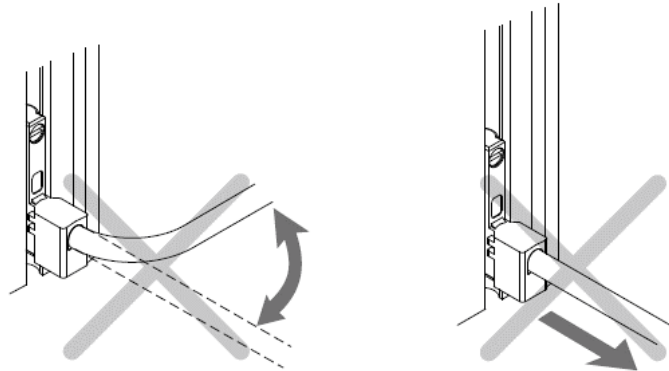

## 6. Do not allow short-circuit of loads.

### <Reed>

If the power is turned ON with a load in a short circuit condition, the switch will be instantly damaged because of excess current flow into the switch.

### <Solid state>

PNP output type auto switches do not have built-in short circuit protection circuits. Carefully handle as the auto switch may be damaged.

## 7. Avoid incorrect wiring.

### <Reed>

A 24 VDC auto switch with indicator light has polarity. The brown lead wire or terminal No.1 is (+), and the blue lead wire or terminal No.2 is (–).

- 1) If connections are reversed, an auto switch will operate, however, the light emitting diode will not light up.

Also, take note that a current greater than that specified will damage a light emitting diode and it will no longer operate.

Applicable model: D-93, A93V

### <Solid state>

- 1) If connections are reversed on a 2-wire type auto switch, the auto switch will not be damaged if protected by a protection circuit, but the auto switch will always stay in an ON state. However, it is still necessary to avoid reversed connections, since the auto switch could be damaged by a load short circuit in this condition.
- 2) If connections are reversed (power supply line + and power supply line –) on a 3-wire type auto switch, the auto switch will be protected by a protection circuit. However, if the power supply line (+) is connected to the blue wire and the power supply line (–) is connected to the black wire, the auto switch will be damaged.

## 8. When the lead wire sheath is stripped, confirm the stripping direction. The insulator may be split or damaged depending on the direction. (D-M9□ only)

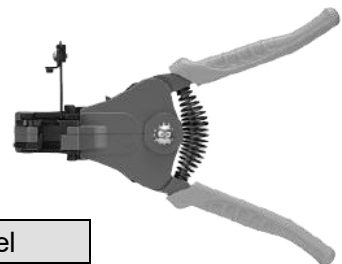
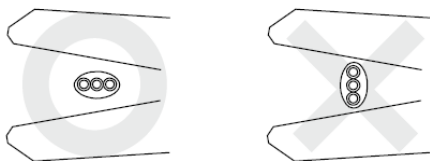

### Recommended Tool

Description	Model
Wire stripper	D-M9N-SWY

\* Stripper for a round cable (Ø2.0) can be used for a 2-wire type cable.

## Operation Environment

### **Warning**

**1. Never use in an atmosphere with explosive gases.**

The structure of auto switches is not intended to prevent explosion. This may lead to explosion hazard.

### **Caution**

**1. Do not use in an area where a magnetic field is generated.**

Auto switches will malfunction or magnets inside rotary actuators will become demagnetized.

**2. Do not use in an environment where the auto switch will be continually exposed to water.**

Although auto switches satisfy IEC standard IP67 construction expect some models (D-A3□, A44□, G39□, K39□, RNK, RPK) do not use auto switches in applications where continually exposed to water splash or spray. This may cause improper insulation or malfunction.

**3. Do not use in an environment with oil or chemicals.**

If auto switches are used in an environment containing coolant, cleaning solvent, various oils, or chemicals even for a short period of time, this may adversely affect the auto switches, resulting in improper insulation, malfunction due to swelling of the potting resin, or hardening of the lead wires.

**4. Do not use in an environment with temperature cycles.**

If temperature cycles other than normal temperature changes are applied, this may adversely affect the insides of the auto switches.

**5. Do not use in an environment where there is excessive impact shock.**

**<Reed>**

When excessive impact ( $300\text{m/s}^2$  or more) is applied to a reed auto switch during operation, the contacts may malfunction and generate or cut off a signal momentarily (1ms or less).

**6. Do not use in an area where surges are generated.**

**<Solid state>**

If there is an equipment unit (electromagnetic lifter, high-frequency induction furnace, motor, or radio, etc.) that generates large surges or electromagnetic waves around cylinders with solid state auto switches or actuators, this may cause the circuit element inside the auto switch to break.

**7. Avoid accumulation of iron waste or close contact with magnetic substances.**

If many iron particles, such as cutting chips or spatters accumulate around a cylinder with the auto switches or an actuator or if a magnetic substance (attracted by a magnet) is put close to a cylinder with the auto switch or an actuator, the magnetic force inside the cylinder or actuator loses, causing the auto switch to malfunction.

**8. Do not use in direct sunlight.**

**9. Do not mount the product in locations where it is exposed to radiant heat.**

**10. Take appropriate measures against the lightning surge on the equipment side as the auto switches do not have any lightning surge resistance specified in the CE marking.**

## Maintenance

### **Warning**

#### **1. Removal of equipment, and supply/exhaust of compressed air.**

Before any machinery or equipment is removed, first ensure that the appropriate measures are in place to prevent the fall or erratic movement of driven objects and equipment, then cut off the electric power and reduce the pressure in the system to zero. Only then should you proceed with the removal of any machinery and equipment.

When machinery is restarted, proceed with caution after confirming that appropriate measures are in place to prevent rotary actuators from moving suddenly.

#### **2. Do not touch a terminal during energizing.**

Touching a terminal during energizing may cause electric shock, malfunction, or auto switch breakage.

### **Caution**

#### **1. Perform the following maintenance periodically in order to prevent possible danger due to unexpected auto switch malfunction.**

##### 1) Secure and tighten auto switch mounting screws.

If screws become loose or the mounting, position is dislocated, retighten them after readjusting the mounting position.

##### 2) Confirm that there is no damage to lead wires.

To prevent faulty insulation, replace auto switches or repair lead wires, etc., if damage is discovered.

##### 3) Confirm the detection setting position.

###### •Red light of 1-color display auto switch

Confirm that the set position stops at the center of the operating range (red display area).

###### •Conform the green light and position of the 2-color display auto switch.

Conform that the set position stops at the center of the appropriate operating range (green display area). If stopped with the red LED lit, the operation may become unstable due to effects of the equipment environment or external disturbance. So, set the mounting position at the center of the appropriate operating range again.

#### **2. Do not use solvents such as benzene, thinner etc. to clean the product.**

They could damage the surface of the body and erase the markings on the body. For heavy stains, use a cloth lightly dampened with diluted neutral detergent, then wipe up any residue with a dry cloth.

## Handling Precautions

### **Caution**

#### **1. Do not remove the protective cover attached to the auto switch (D-A9 · (V)/Z7 · /Z80 type) product body until immediately before the product is to be mounted to the rotary actuator.**

The protective cover attached to the body of the D-A9 · (V)/Z7 · /Z80 type auto switch is intended to reduce impact during handling and prevent the auto switch holding screw from falling out.

In particular, it reduces impact to the auto switch body if it is accidentally bumped when mounting a connector or tubing to the auto switch, so do not remove it until immediately before mounting it to the rotary actuator.

# 1. Outline

This operation manual explains “rack and pinion type compact rotary actuator”.  
Then using the product, load (moment of inertia), rotation time and other factors have to be considered.  
So, confirm the specification of the product prior to use.

## 1-1 Specifications

Table 1. Specification-1

Size	10	15	20	30	40
Fluid	Air (Non-lube)				
Max. operating pressure	0.7 MPa		1.0 MPa		
Min. operating pressure	0.15 MPa		0.1 MPa		
Ambient and fluid temperature	0 to 60°C (No freezing)				
Cushion	Not attached				
Angle adjustment range	Each rotation end $\pm 5^\circ$				
Rotation angle	90°, 180°				
Port size	M5×0.8		Rc 1/8, G 1/8, NPT 1/8, NPTF 1/8		
Output(N·m) *	0.3	0.75	1.8	3.1	5.3

\* Output under the operating pressure at 0.5 MPa.

Table 2. Specification-2

Size	Allowable kinetic energy (J)	Stable operational rotation time adjusting range (s/90°)
10	0.00025	0.7 to 5
15	0.00039	0.7 to 5
20	0.025	1 to 5
30	0.048	1 to 5
40	0.081	1 to 5

Table 3. Specification-3

Size	Weight (g)		Internal volume (cm <sup>3</sup> )	
	90°	180°	90°	180°
10	120	150	1.2	2.2
15	220	270	2.9	5.5
20	600	700	7.1	13.5
30	900	1100	12.1	23.0
40	1400	1600	20.6	39.1

\* Excluding the weight of auto switch.

## 1-2 Effective torque

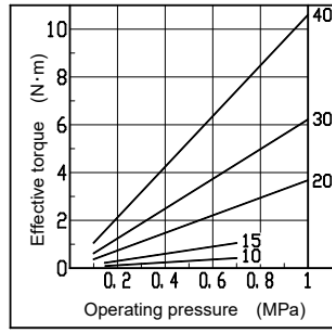

Graph 1. Effective torque

## 1-3 Rotation range

When pressurized from the A port, the shaft will rotate clockwise.

Flat face and parallel key position indicate B port is pressurized.

By adjusting the adjustment bolt, the rotation end can be set within the ranges shown in Figure 1.

If the hexagon nut is excessively tightened when securing the adjustment bolt, the sealing washer may be damaged. Tighten the hexagon nut to a torque not exceeding the value specified in Table 4.

Depending on the operating environment and conditions, the fixing nut may loosen as the number of operating cycles increases. If this causes operational issues, readjust as necessary.

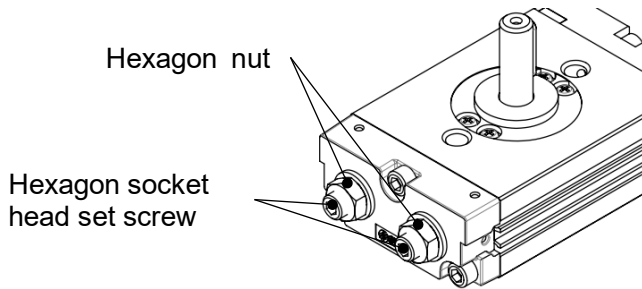
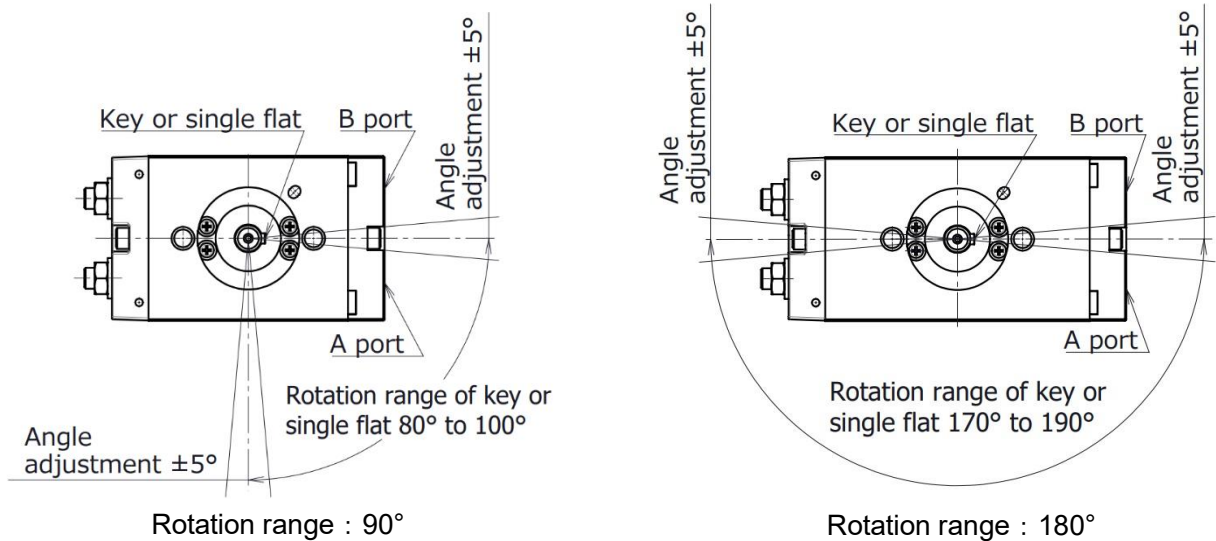

Figure 1

Table 4. Tightening torque

Size	Tightening torque(N · m)
10	1.5
15	2.6
20	5.8
30	5.8
40	12.5

## 2. Internal structure and parts description

2-1 Size 10,15

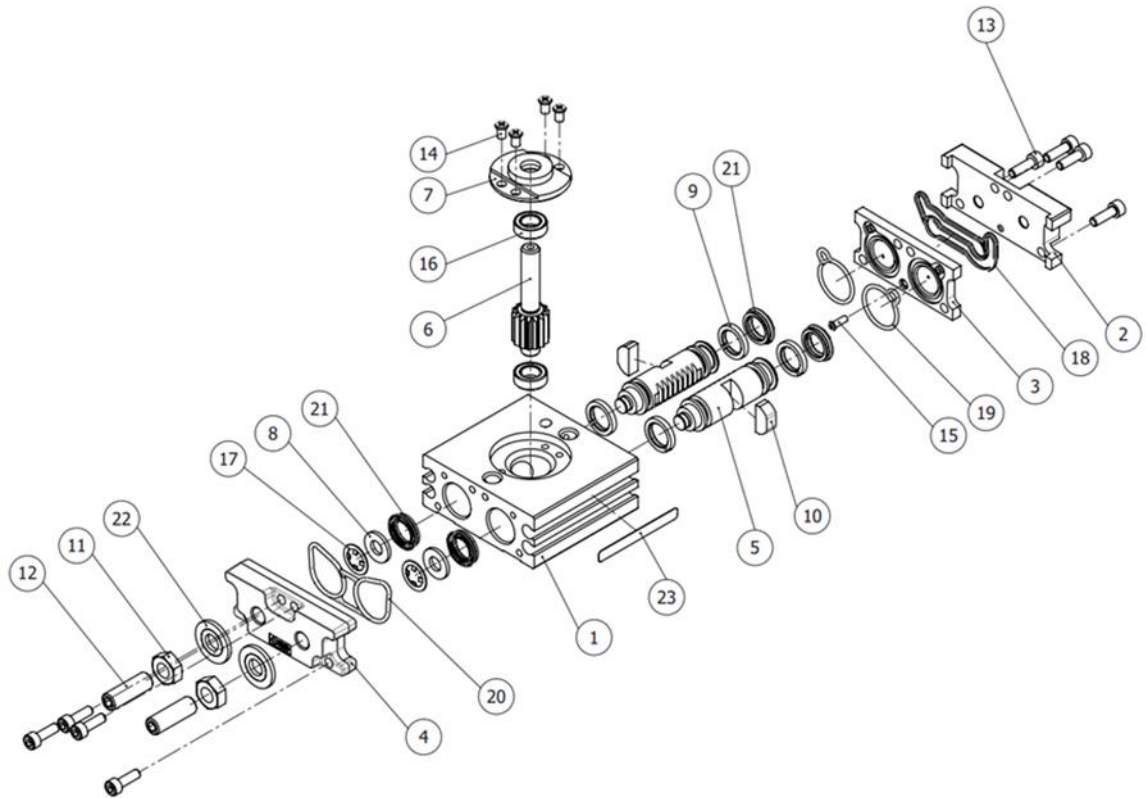

23	Heat transferred label	1	
22	Seal washer	2	
21	Piston seal	4	
20	Gasket for endcover	1	
19	Gasket for cover	2	
18	Seal	1	
17	Type CS retaining ring	2	
16	Bearing	2	
15	Cross recessed No.0 screw	1	
14	Cross recessed No.0 screw	4	
13	Hexagon socket head cap screw	8	
12	Hexagon socket head set screw	2	
11	Hexagon nut	2	
10	Magnet	2	With auto switch only
9	Wearing	4	
8	Seal retainer	2	
7	Bearing retainer	1	
6	Shaft	1	
5	Piston	2	
4	End cover	1	
3	Plate	1	
2	Cover	1	
1	Body	1	
No.	Description	Qty.	Note

2-2 Size 20,30,40

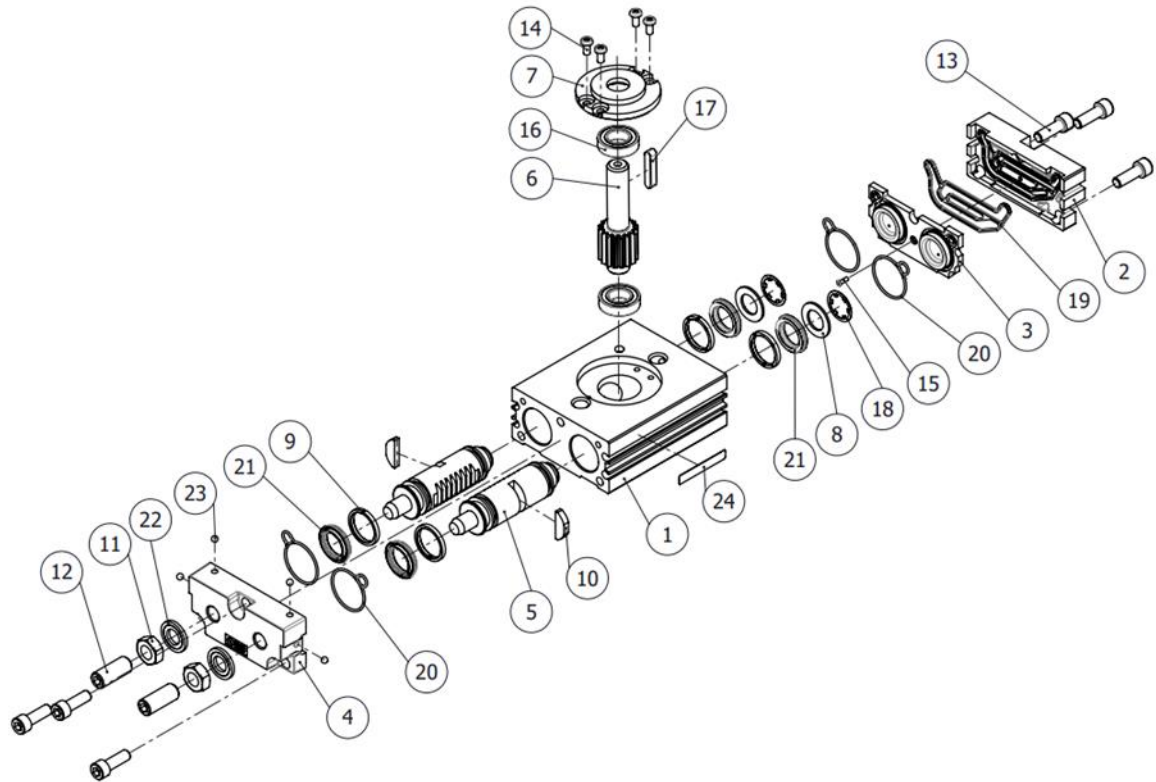

24	Heat transferred label	1	
23	Steel ball	4	
22	Seal washer	2	
21	Piston seal	4	
20	Gasket	4	
19	Seal	1	
18	Type CS retaining ring	2	
17	Parallel key	1	
16	Bearing	2	
15	Cross recessed No.0 screw	1	
14	Cross recessed screw	4	
13	Hexagon socket head cap screw	6	
12	Hexagon socket head set screw	2	
11	Small hexagon nut	2	
10	Magnet	2	With auto switch only
9	Wearing	4	
8	Seal retainer	2	
7	Bearing retainer	1	
6	Shaft	1	
5	Piston	2	
4	End cover	1	
3	Plate	1	
2	Cover	1	
1	Body	1	
No.	Description	Qty.	Note

### 3. Basic circuit

#### 3-1 Circuit structure

The standard circuit for operating a rotary cylinder with an air filter, regulator, solenoid valve and speed controller is shown in Figure 2 below.

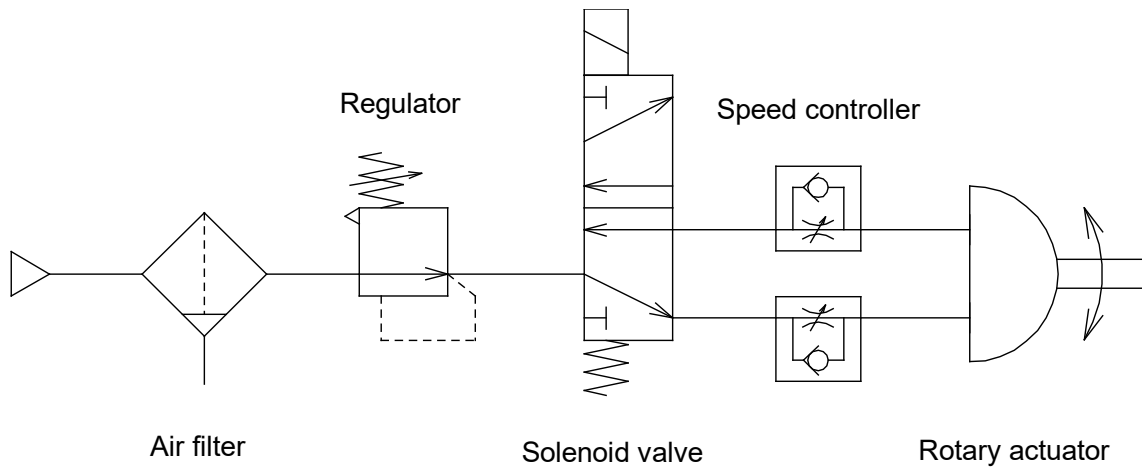

Figure 2. Basic circuit

#### 3-2 Recommended equipment

Table 5 shows recommended solenoid valve, speed controller, tube for the basic circuit in Figure 2.

Table 5. Recommended equipment

Size	Solenoid valve (CV value)	Speed controller	Tubing
10	0.05 to 0.2	AS1000 series	Outer diameter $\geq$ 2.5mm
15			
20	0.15 to 0.2	AS2000 series	Outer diameter $\geq$ 4mm
30			
40			

## 4. Mounting

### 4-1 Confirmation of allowable load

Shaft of load below shows the allowable load when no moving load applied to axis direction.

Avoid applying load to the axis directly as much as possible.

Table 6. Allowable load

Size	Load direction			
	Fsa(N)	Fsb(N)	*Fr(N)	M(N · m)
10	15.7	7.8	14.7	0.21
15	19.6	9.8	19.6	0.32
20	49	29.4	49	0.96
30	98	49	78	1.60
40	108	59	98	2.01

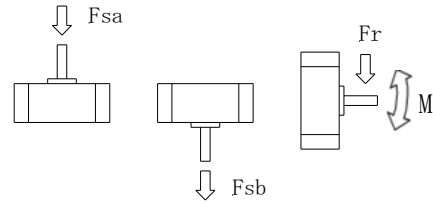

Figure 3

\*Point of application of force of Fr is the center of shaft flat face and longer dimension of the key.

Provided that a dynamic load is not generated, a load that is within the allowable radial/thrust load can be applied.

However, applications in which the load is applied directly to the shaft should be avoided as much as possible.

The methods such as those described below are recommended to prevent the load from being applied directly to the shaft in order to ensure a proper operating condition.

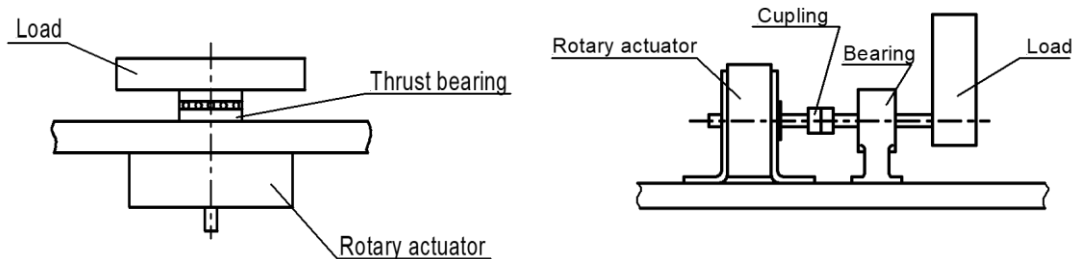

Figure 4

### 4-2 Operation of axis fitting referring

As in Figure 5, alignment of the rotary actuator and the mating axis is necessary when the rotary actuator is used with its axis lengthened. If misaligned, partial load becomes high and the axis is applied with excessive bend moment. Under this condition, shaft operation is not available which lead to cause the damage of axis. In this case, flexible fitting (flexible joint specified by JIS) becomes necessary.

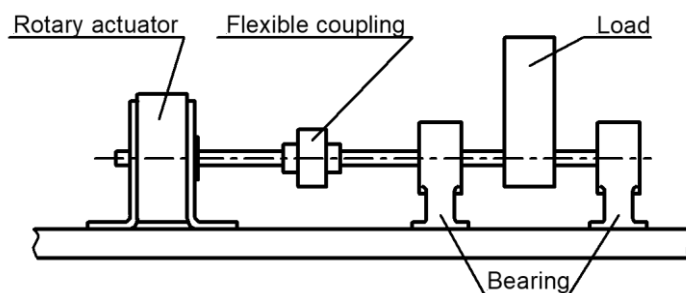

Figure 5

#### 4-3 Flange application

The L dimensions of this unit are shown in Table 7.

When hexagon socket head cap bolt of the JIS standard is used, the head of the bolt will recess into the groove of actuator.

Table 7

Size	L(mm)	Bolt
10	13	M 4
15	16	M 4
20	22.5	M 6
30	24.5	M 8
40	28.5	M 8

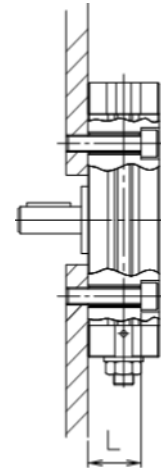

Figure 6

#### 4-4 Direction of piping and operation

Table 8. Port size

Size	Port size
10	M5x0.8
15	
20	Rc 1/8, G 1/8 NPT 1/8, NPTF 1/8
30	
40	

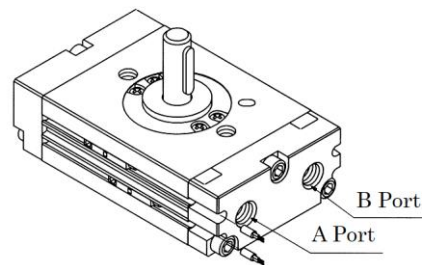

Figure 7. Port location

Fixed orifice is equipped in the rotary actuator port. Don't enlarge the hole. Enlarged hole increases the operation speed of the rotary actuator and the impact which lead to cause the breakage of the rotary actuator.

The axis rotates clockwise when pressurized from A port. Perform followings before piping.

- a) Flush or clean the piping to eliminate metal swarf, cutting oil and dust before connecting piping.
- b) Mind so that the piping swarf and sealing material do not enter into the piping when screwing in piping and fitting. When using the seal tape, leave 1.5~2 threads. (See Figure 8)

#### 4-5 Operating air

Air supplied to the rotary actuator shall be cleaned by the filter. CRQ2X series is lubrication free.

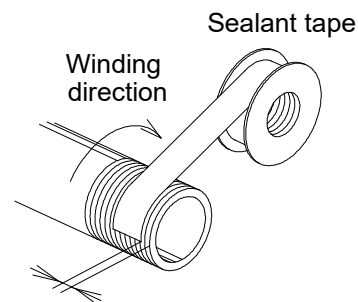

Expose approx. 2 threads  
Figure 8. Wrapping of pipe tape

## 5. Setting rotation time

The load inertia lead to cause the damage of the shaft and internal parts even if generated torque of rotary actuator is small. The calculation of load inertia moment and kinetic energy is necessary to set the rotation time for operating the rotary actuator.

### 5-1 Inertia moment

Inertia moment indicates scales how hard to rotate the object, and also how hard to stop rotating object. An object started by the rotary actuator is getting to have inertia force. When the rotary actuator stops at the stroke end, the actuator received big impact (kinetic energy) due to inertia force. Please refer below for calculation of kinetic energy

$$E = \frac{1}{2} \times I \times \omega^2$$

E : Kinetic energy      J  
I : Inertia moment       $\text{kg} \cdot \text{m}^2$   
 $\omega$  : Angular speed       $\text{rad}/\text{s}$

Allowable kinetic energy for the rotary actuator is limited. The limit of rotation time is obtained by calculating inertia moment. Please refer following for obtaining inertia moment.

#### Basic inertia moment

$$I = m \cdot r^2$$

m : Weight of load.      kg  
r : Load center of gravity and distance of rotation axis.      m

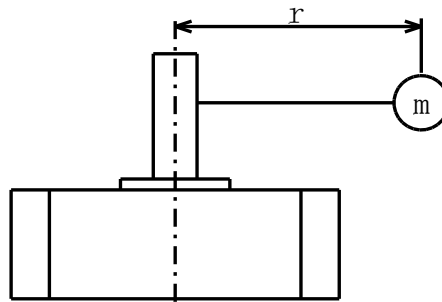

Figure 9

This shows inertia moment of “m (weight)” at “r” from the rotation axis. Calculation of inertia moment depends on the shape of the object. Please refer the shaft on the next page for inertia moment calculation.

## Shaft for calculation of Inertia moment

**① Thin rod**

Location of rotation axis: Perpendicular to the rod and passes one end

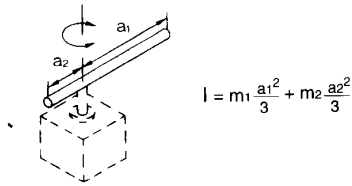

**⑥ Column (Including thin round board)**

Location of rotation axis: Center axis

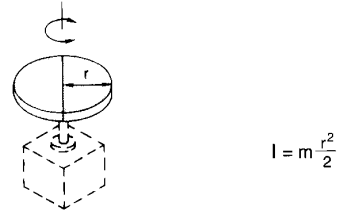

**② Thin rod**

Location of rotation axis: Passes the center of gravity of the rod

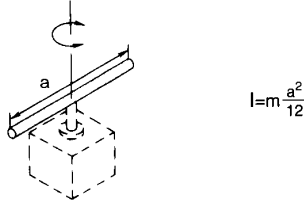

**⑦ Sphere**

Location of rotation axis: Diameter



**③ Thin rectangular board (Rectangular parallelepiped)**

Location of rotation axis: Passes the center of gravity of the board

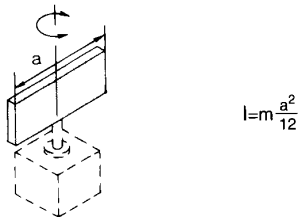

**⑧ Thin round board**

Location of rotation axis: Diameter



**④ Thin rectangular board (Rectangular parallelepiped)**

Location of rotation axis: Perpendicular to the board and passes one end (It is the same for the rectangular parallelepiped made with thicker board)

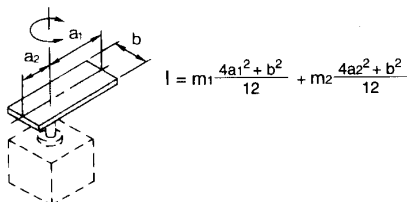

**⑨ With a load at the end of the lever**

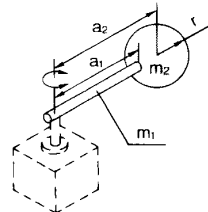

$$I = m_1 \frac{a_1^2}{3} + m_2 a_2^2 + K$$

Example)  $K = m_2 \frac{2r^2}{5}$ , referring to the case ⑦ that the state of  $m_2$  is a ball.

**⑤ Thin rectangular board (Rectangular parallelepiped)**

Location of rotation axis: Passes the center of gravity of the board and perpendicular to the board (It is the same for the rectangular parallelepiped made with thicker board)

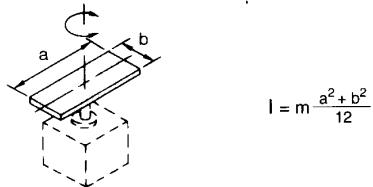

**⑩ Gear Transmission**

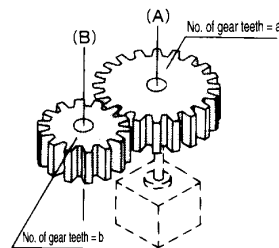

1. Calculate moment of inertia  $I_B$  around axis (B).
2. Replace moment of inertia  $I_B$  around axis (A) with  $I_A$ .  
 $I_A = \left(\frac{a}{b}\right)^2 I_B$

## 5-2 Kinetic energy

Table 9 shows the allowable kinetic energy of the rotary actuator.  
The end angular speed  $\omega$  is obtained by:

$$\omega = \frac{2\theta}{t}$$

$\theta$  : Rotation angle      rad

$t$  : Rotation time        s

Table 9. Allowable kinetic energy

Size	Allowable kinetic energy (J)
10	0.00025
15	0.00039
20	0.025
30	0.048
40	0.081

Kinetic energy E is obtained by:

$$E = \frac{1}{2} \times I \times \omega^2$$

Therefore, the rotary actuator rotation time is:

$$t \geq \sqrt{\frac{2 \times I \times \theta^2}{E}}$$

E : Allowable kinetic energy

J

$\theta$  : Rotation angle

rad

I : Inertia moment

kg · m<sup>2</sup>

Note) IF the rotating speed is slower than 2s/90 degree, it should be calculated to 2s/90 degree.

Angular speed  $\omega$  after t sec. at isometric acceleration is obtained as below

$$\omega = \dot{\omega} \times t \text{----- (1)} \quad \dot{\omega} : \text{Angular acceleration}$$

$$\theta = \int \dot{\omega} t \, dt = \frac{1}{2} \dot{\omega} t^2 + C \text{----- (2)} \quad C : \text{Integral constant}$$

Seconds of arc at  $t = 0$  is  $\theta = 0$ . Therefore  $C = 0$ .

$$\theta = \frac{1}{2} \dot{\omega} t^2 = \frac{1}{2} \omega t$$

Therefore,

$$\omega = \frac{2\theta}{t}$$

## 6. Rotary actuator with auto switch

The piston of rotary actuator with auto switch is attached with magnet on it, and equipped with auto switch outside to detect the piston position (shaft flat face and key groove position).

### 6-1 Auto switch specification

Table 10

Type	Special function	Electrical entry	Indicator	Wiring (Output)	Load voltage		Autoswitch part no.		Lead wire length (m)				Applicable load				
					DC	AC	Electrical entry		0.5	1	3	5					
							Vertical	Horizontal	(Nil)	(M)	(L)	(Z)					
Solid state auto switch	—	Grommet	Yes	3 wires (NPN)	5V,12V	—	M9NV	M9N	●	●	●	○	—	Relay, PLC			
				3 wires (PNP)			M9PV	M9P	●	●	●	○					
				2 wires			M9BV	M9B	●	●	●	○					
	Diagnosis display (2-color)			3 wires (NPN)	24V		M9NWV	M9NW	●	●	●	○					
				3 wires (PNP)			M9PWV	M9PW	●	●	●	○					
				2 wires			M9BWV	M9BW	●	●	●	○					
				3 wires (NPN)			5V,12V	M9NAV	M9NA	○	○	●			○		
	3 wires (PNP)			M9PAV	M9PA			○	○	●	○						
	2 wires			M9BAV	M9BA			○	○	●	○						
	water resistant (2-color)			3 wires (NPN)	24V		No	3 wires (NPN equiv.)	—	5V	A96V	A96			●	●	●
2 wires		100V	A93V	A93		●		●			●	●	—	Relay, PLC			
—			Grommet	Yes		2 wires		24V	12V	100V or less	A90V	A90	●	●	●	●	IC circuit

\*Lead wire length symbols : 0.5m···Nil (Example) M9NW  
1m·····M (Example) M9NWM  
3m·····L (Example) M9NWL  
5m·····Z (Example) M9NWX

\*Auto switches marked with "○" are made to order specification.

\*Although it is possible to mount water resistant type auto switches, note that the rotary actuator itself is not of water resistant construction.

### Reed auto switch

- Lead wire — D-A90(V) and D-A93(V): Oil proof vinyl cabtire cord  
Ø2.7 0.18mm<sup>2</sup>×2-core (brown, blue) 0.5m  
D-A96(V): Oil proof vinyl cabtire cord  
Ø2.7 0.15mm<sup>2</sup>×3-core (brown, black, blue) 0.5m
- Insulation resistance — 50 MΩ or more (500 VDC measured via megohmmeter)  
(between lead wire and case)
- Withstand voltage— 1000 VAC for 1 minute (between lead wire and case)
- Operating time — 1.2ms
- Ambient temperature — -10 to 60°C
- Impact resistance — 300m/s<sup>2</sup>
- Leakage current — None
- Enclosure — IEC60529 Standard IP67
- When the lead wire length is 3m, the part number is suffixed with "L". ex)D-A90L

### Solid state auto switch

- Lead wire — D-M9B(V): Flexible vinyl sheath cable  
2.7×3.2 ellipse 0.15mm<sup>2</sup>×2-core (brown, blue) 0.5m  
D-M9N(V), D-M9P(V): Flexible vinyl sheath cable  
2.7×3.2 ellipse 0.15mm<sup>2</sup>×3-core (brown, black, blue) 0.5m
- Insulation resistance — 50 MΩ or more (500 VDC measured via megohmmeter)  
(between lead wire and case)
- Withstand voltage— 1000 VAC for 1 minute (between lead wire and case)
- Operating time — 1ms or less
- Ambient temperature — -10 to 60°C
- Impact resistance — 1000m/s<sup>2</sup>
- Enclosure — IEC60529 Standard IP67
- When the lead wire length is 3m, the part number is suffixed with "L". ex)D-M90L

### 6-2 Auto switch installation

When tightening the auto switch mounting screw, use a precision screwdriver with a handle of 5 to 6 mm in diame  
Use the designated slotted set screw (M2.5×4L) to mount the auto switch.

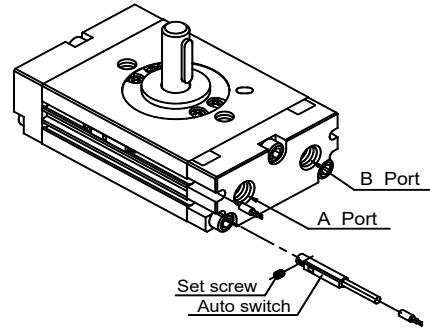

Figure 10

### 6-3 Auto switch set position

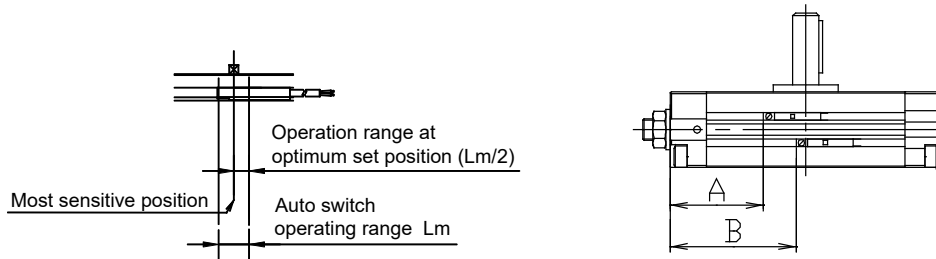

Figure 11

Table 11

Size	Rotation angle (deg)	Reed auto switch				Solid state auto switch			
		A (mm)	B (mm)	Operation range $\theta_m$ (deg)	Hysteresis range(deg)	A (mm)	B (mm)	Operation range $\theta_m$ (deg)	Hysteresis range(deg)
10	90	15	21.5	63	12	19	25.5	61	5
	180	18	31			22	35		
	360	25	52.5			29	56.5		
15	90	18.5	27	52	9	22.5	31	47	4
	180	22.5	39.5			26.5	43.5		
	360	30.5	64.5			34.5	68.5		
20	90	36	48.5	41	9	40	52.5	40	4
	180	42	67.5			46	71.5		
	360	55.5	106			59.5	110		
30	90	43	59	32	7	47	63	29	2
	180	51	82			55	86		
	360	62	125.5			66	129.5		
40	90	50	69	24	5	54	73	24	2
	180	59.5	97.5			63.5	101.5		
	360	72.5	152			76.5	156		

Operation range  $\theta_m$  : The value in which the auto switch operating range “Lm” is converted to axis rotating value.

Hysteresis range : Value of auto switch hysteresis converted to an angle.

Note) The above values are only provided as a guideline, and they are not guaranteed.  
In the actual setting, adjust them after confirming the auto switch operating condition.

## 6-4 Internal structure and operation principle

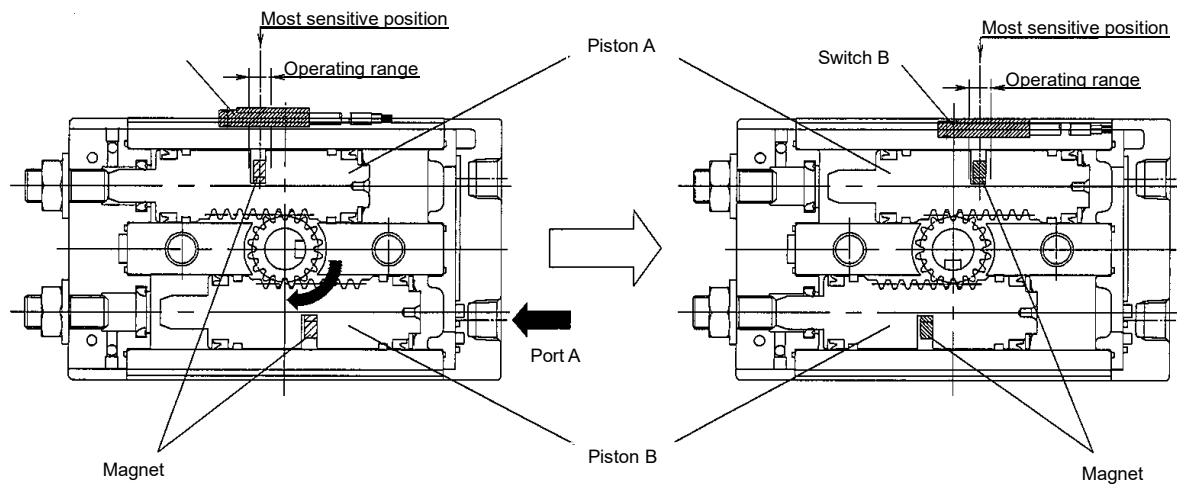

Figure 12

In Figure 12, the switch A is turned on. When pressurized from port A, piston B moves to the left and piston A moves to the right, and the shaft rotates clockwise. At this point, magnet goes out of switch A's operation range to turn off switch A. Then, piston A moves right, and the magnet goes into switch B's operation range to turn on switch B.

## 7. Maintenance and Inspection

Periodic inspection is necessary for optimum use. Generally, annual inspection is recommended for the rotary actuator. Even if no problem is found, seal parts replacement is recommended every three years.

It is highly possible that the actuator is operated out of specification when the components like shaft, pinion, rack, bearing are broken. Please revise the operating condition. In this case, please return the broken actuator to SMC to repair.

### 7-1 Periodic inspection

Check followings for periodic inspection

- (1) If the rotary actuator set screw become loose
- (2) If the rotary actuator set frame become loose
- (3) Smooth operation
- (4) External leak

If problem found, tighten additionally or disassemble to repair.

### 7-2 Disassemble and reassemble

#### 7-2-1 Caution on disassemble

- (1) Disassemble where clean and spacious place.
- (2) Cover the rotary actuator pipe inlet and the end of rubber hose after removing the rotary actuator.
- (3) Mind not to damage internal sliding surface of the rotary actuator when disassembling it.
- (4) Please consult with us when you have any question on disassembling and inspection.

Table 12. Replacement parts

Description	Size								
	10			15			20		
Seal kit	P473010-23			P473020-23			P473030-23		
Parts included in seal kit	No.	Description	Qty.	No.	Description	Qty.	No.	Description	Qty.
	9	Wearing	4	9	Wearing	4	9	Wearing	4
	18	Seal	1	18	Seal	1	19	Seal	1
	19	Gasket for cover	2	19	Gasket for cover	2	20	Gasket	4
	20	Gasket for end cover	1	20	Gasket for end cover	1	21	Piston seal	4
	21	Piston seal	4	21	Piston seal	4	22	Seal washer	2
22	Seal washer	2	22	Seal washer	2				

Description	Size					
	30			40		
Seal kit	P473040-23			P473050-23		
Parts included in seal kit	No.	Description	Qty.	No.	Description	Qty.
	9	Wearing	4	9	Wearing	4
	19	Seal	1	19	Seal	1
	20	Gasket	4	20	Gasket	4
	21	Piston seal	4	21	Piston seal	4
	22	Seal washer	2	22	Seal washer	2

Please refer to Page 21 and 22 for the product construction.

A grease pack (10g) is included.

When only a grease pack is needed, order with the following part number.

**Grease pack part number : P523010-21 (10g)**

### 7-2-2 Disassembling procedure

- (1) Loosen cross recessed No.0 screw (size 10,15) or cross recessed screw (size 20,30,40) .
- (2) Pull out the bearing retainer and the shaft from the body. Remove the bearing from the housing at this time.
- (3) Loosen hexagon socket head cap screw to remove the cover assembly and the end cover assembly.
- (4) Push piston assembly from one side to pull out two piston assemblies from the body.
- (5) Take out the bearing from the body.

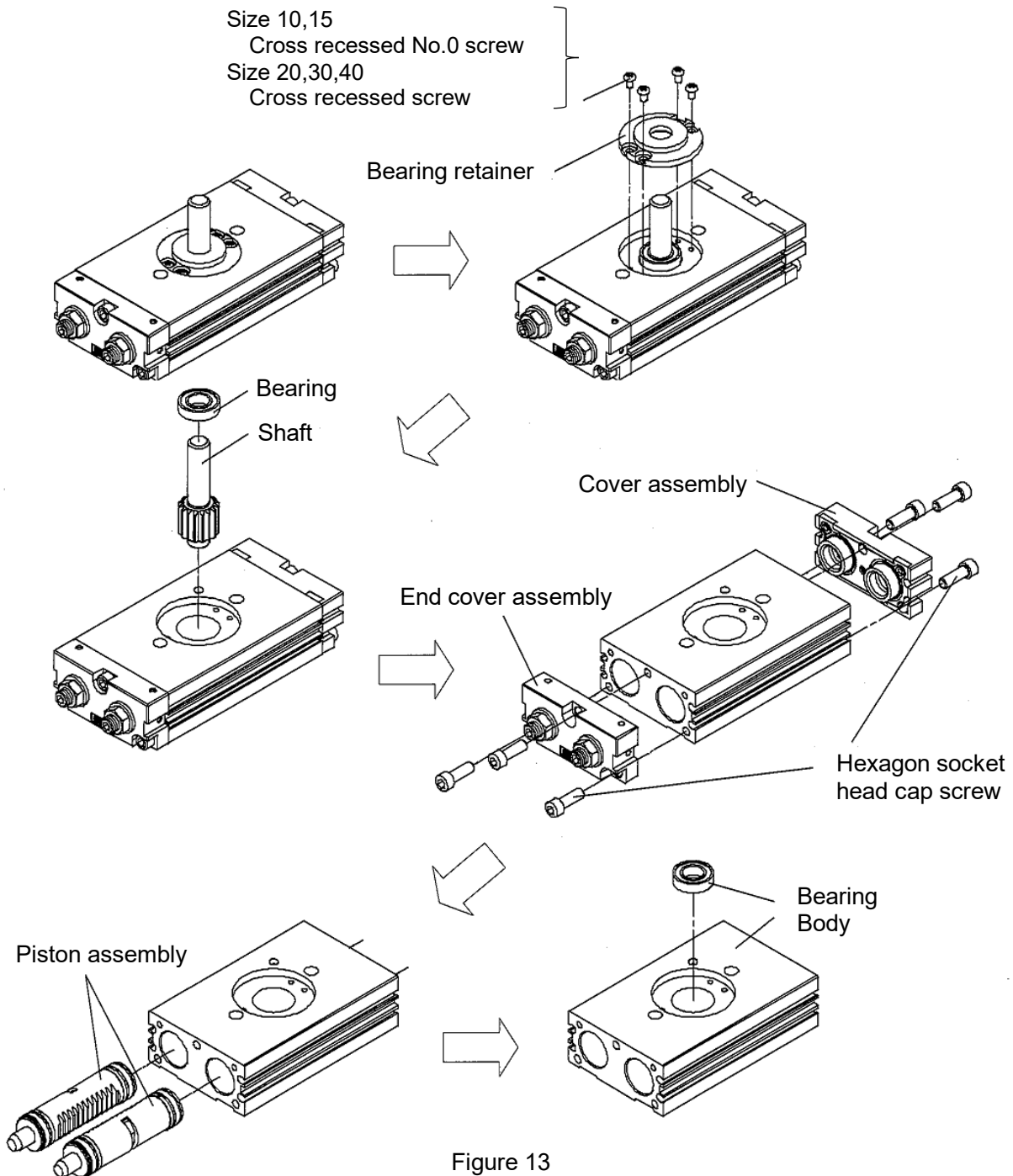

Figure 13

### 7-2-3 Assembly procedure

- (1) Clean each component sufficiently before assembly to prevent a dust from sticking to them. Apply the grease which is included in the seal kit to each part shown in Table 13. The correct amount of grease to be applied should be enough so there is a thin film on the surface of components which is shiny to the eye.

Table 13. Parts applied with grease

Description	Grease applied points	Grease
Cylinder internal surface	Inside of cylinder	P523010-21
Piston	The mouting portion of the piston seal	
Piston seal	The entire surface	
Gasket for cover (Size 10,15)	The entire surface	
Gasket for end cover (Size 10,15)	The entire surface	
Gasket (Size 20,30,40)	The entire surface	
Seal	The entire surface	

#### **Body assembly**

Apply grease after wiping the inside of the cylinder with alcohol, and mount the bearing on the housing.

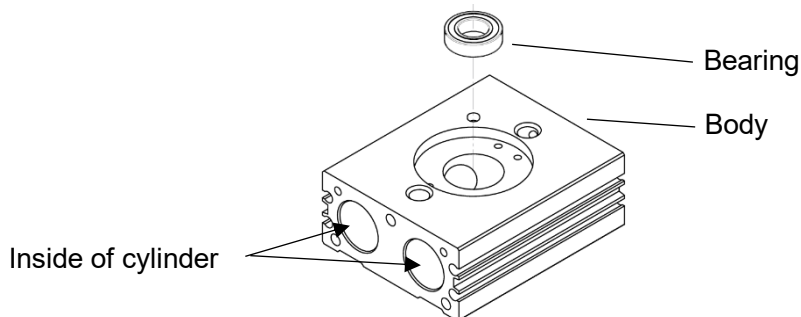

Figure 14

#### **Piston assembly**

Pay attention to the installation direction of the piston seal as the direction is specified. Then mount the piston seal to the piston, taking care not to damage the piston seal.

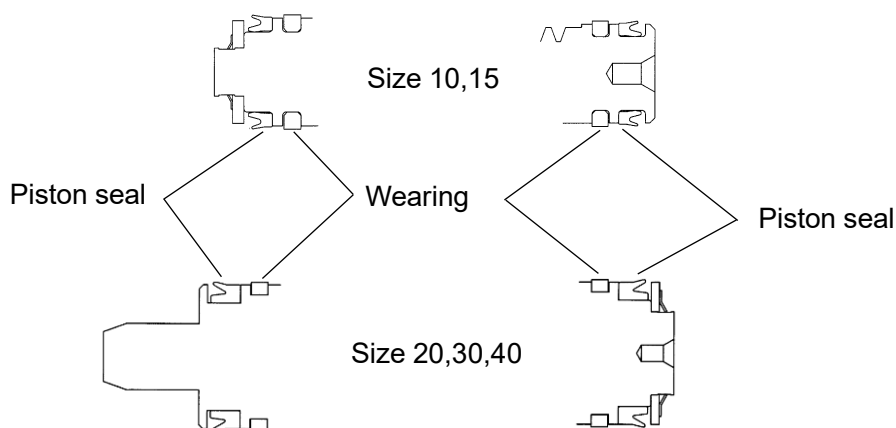

Figure 15

**Cover assembly**

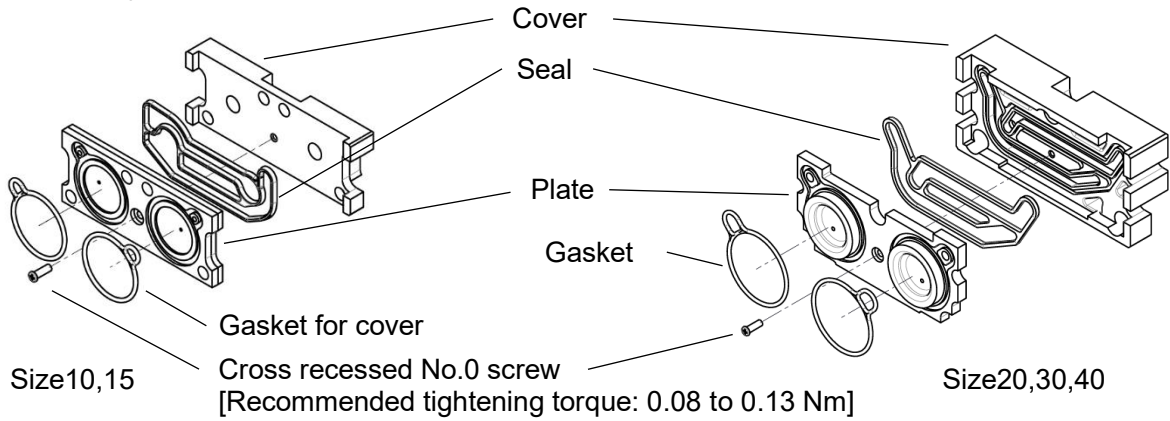

Figure 16

**End cover assembly**

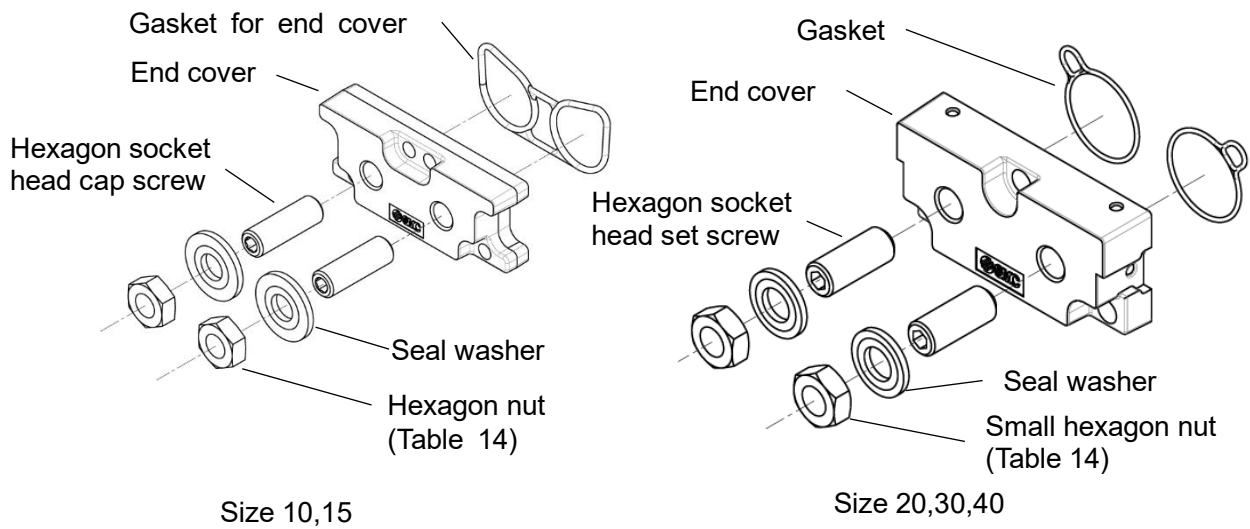

Figure 17

Table 14. Tightening torque

Size	Tightening torque[N · m]
10	1.5
15	2.6
20,30	5.8
40	12.5

To prevent damage to the seal washer, do not exceed the torque values shown in Table 14 when tightening hexagon nuts.

- (2) Insert the piston assembly into the body assembly. At this time, the piston seals pass the opening of the cylinder and should be pressed inward not to be cut on the edge of bore. Pay attention to the insertion direction of the piston assembly.

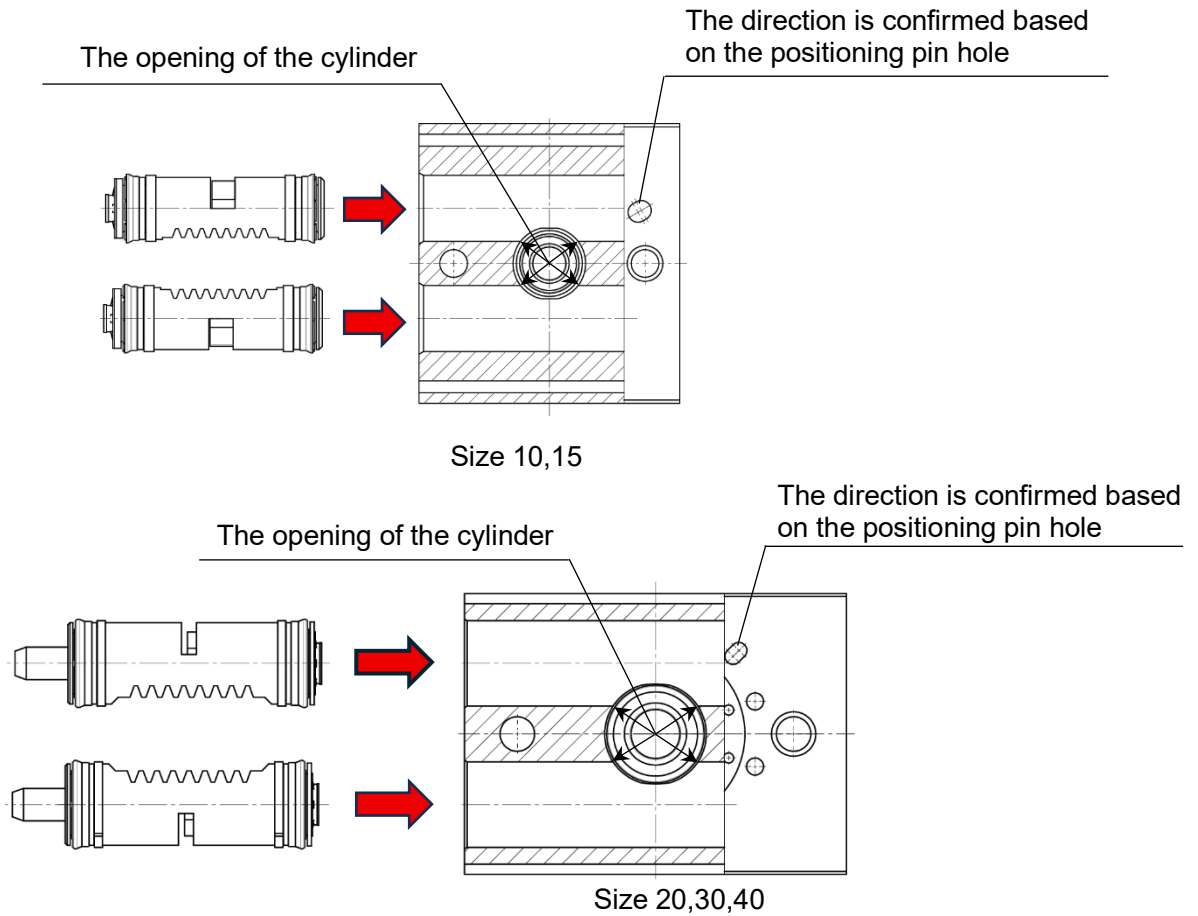

Figure 18

- (3) Hold the piston in place and install the pinion gear on the piston. Figure 19 shows the piston position and Figure 20 shows the pinion gear assembly angle.

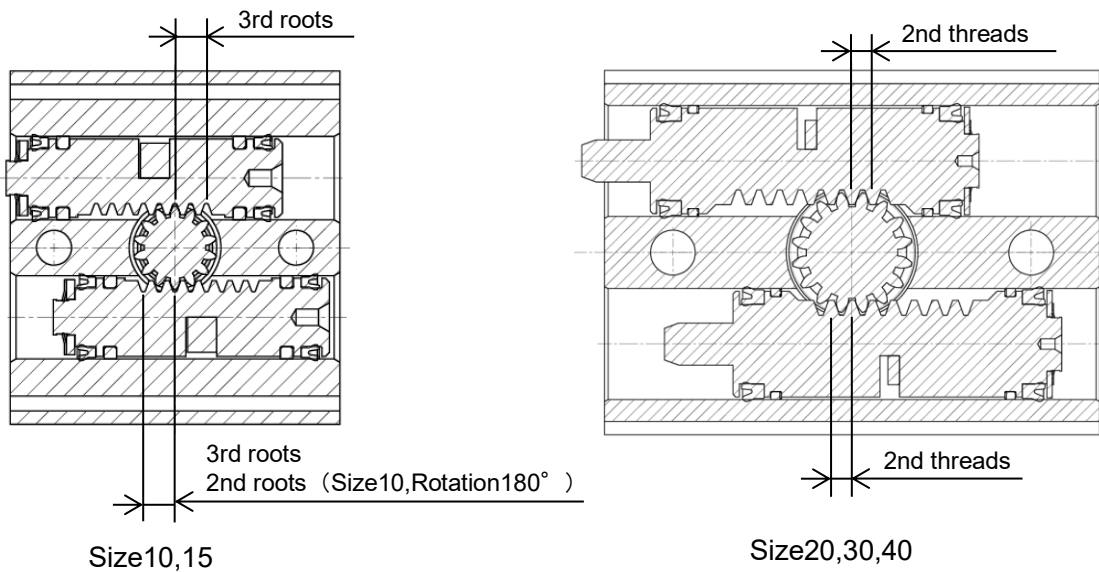

Figure 19

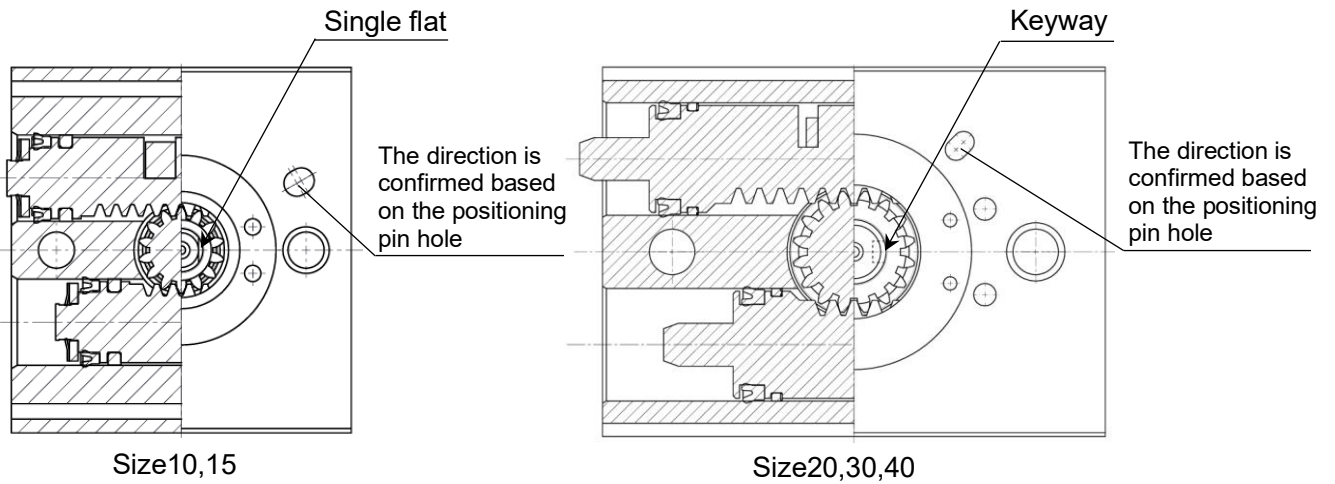

Figure 20

(4) Mount the bearing retainer on the body.

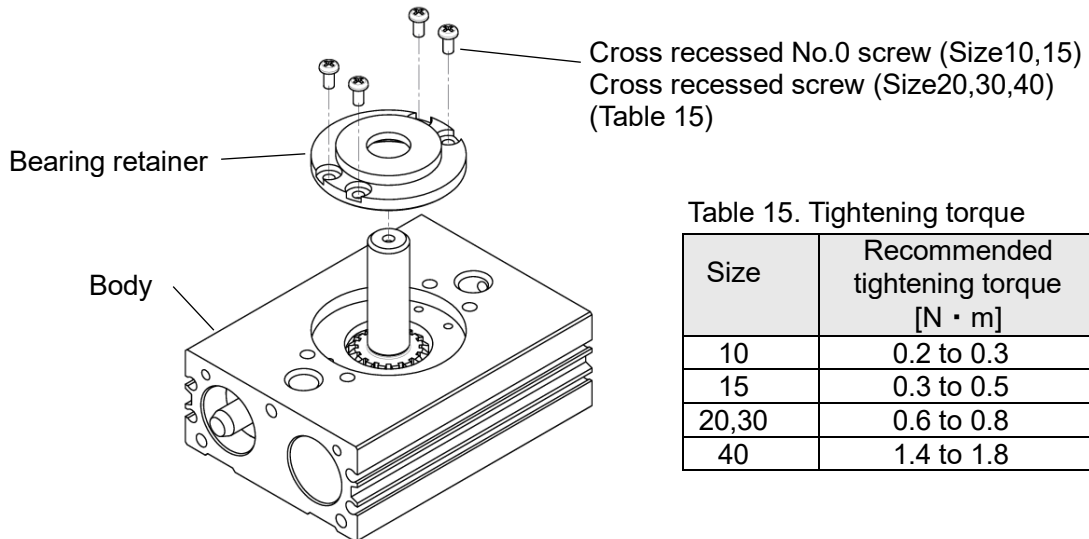

Figure 21

Table 15. Tightening torque

Size	Recommended tightening torque [N · m]
10	0.2 to 0.3
15	0.3 to 0.5
20,30	0.6 to 0.8
40	1.4 to 1.8

(5) Assemble the cover assembly and end cover assembly onto the body.

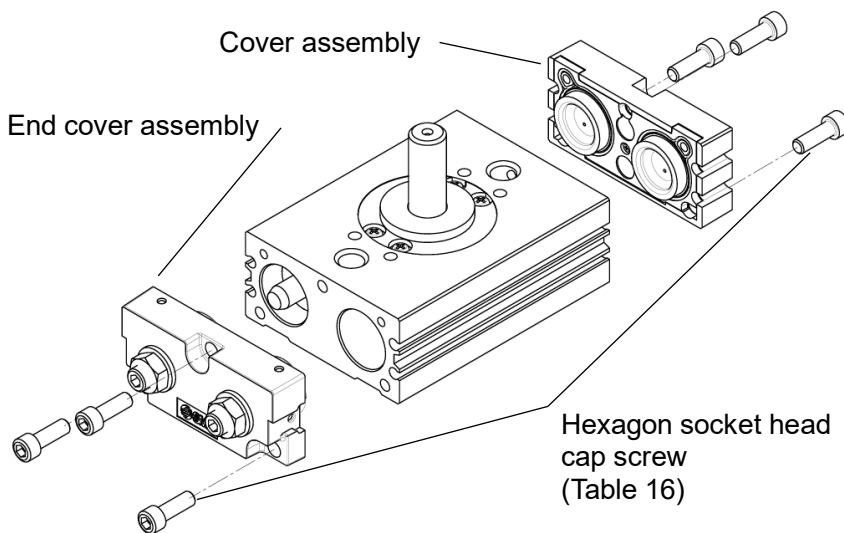

Figure 22

Table 16. Tightening torque

Size	Recommended tightening torque [N · m]
10	0.2 to 0.3
15	0.3 to 0.5
20,30	4.2 to 5.2
40	7.2 to 8.7

(6) Perform operation test after assembling and check external leakage.

### 7-3 Troubleshooting

Problem	Possible cause	Solution
Rotary actuator does not move	Supply pressure is not applied correctly.	Correctly set the regulator at the supply pressure side.
	The directional switching valve (such as a solenoid valve) does not switch.	Correctly apply a signal to the directional switching valve (such as a solenoid valve).
	Air leakage from piping.	Inspect the piping and stop the leakage.
	The restrictor in the port is clogged.	Clean the restrictor. Take the following countermeasures: (1) Blow air through the piping again. (2) Inspect the air filter.
Operation is not smooth. (stick-slip)	The load has some friction.	Reduce the friction resistance.
	The rotation shaft and the item used with it are not aligned.	Align the two centers or use a flexible fitting.
	Insufficient output due to a low supply pressure.	To obtain shaft operation, adjust the supply pressure to make the load ratio appropriate.
	Speed controller is restricted too much.	Adjust the speed controller so that the rotating marks will be in the adjusting range.
Extreme rotating angle changes.	Internal parts are broken.	Replace the rotary actuator with the new one. Then calculate the kinetic energy applied to the rotary actuator and adjust the load and rotation speed to make the value within the allowable kinetic energy.
Air leakage from the shaft	Piston seal is worn out.	The seal parts need to be replaced. Contact SMC.

Problem	Possible cause	Solution
The pinion gear is broken.	Excessive kinetic energy was applied to the rotary actuator.	Replace the rotary actuator with the new one. Then calculate the kinetic energy applied to the rotary actuator and adjust the load and rotation speed to make the value within the allowable kinetic energy.
Insufficient rotating Angle.	The adjustment bolt for angle adjustment is set at a smaller angle than required.	Set the adjustment bolt correctly.
The auto switch will not operate or operates incorrectly.	The auto switch is mounted in an inappropriate position.	Mount the auto switch in the correct position.
	Effect of an external magnetic field.	Check that there is no strong magnetic field present.
	Trouble with the electrical circuit	Check that there is no trouble with the electrical circuit.
	Trouble with the electrical specification	Check there is no trouble with the electrical specification.

#### Revision history

- A: The contents have been revised to the latest version.
- B: Revised safety instructions.
- C: Indicate the tightening torque of the hexagon nut. Revision of auto switch list, and Maintenance and Inspection.

## SMC Corporation

Tel: + 81 3 5207 8249 Fax: +81 3 5298 5362  
URL <https://www.smcworld.com>

---

Note: Specifications are subject to change without prior notice and any obligation on the part of the manufacturer.  
© SMC Corporation All Rights Reserved