



# Operation Manual

PRODUCT NAME

Clamp Cylinder

MODEL / Series / Product Number

CK1 \* 40 & 63 \* — \* \* Z1  
CKG1 \* 40 & 63 \* — \* \* Z1 — \* \*  
CKP1 \* 40 & 63 \* — \* \* Z1 — \* \*

**SMC Corporation**

# Contents

Safety Instructions	P2
1. Specifications	P4
1-1. Specifications	
2. Installation and Handling	P4
2-1. Air supply	
2-2. Design	
2-3. Mounting and Installation	
2-4. Environment	
2-5. Speed control	
2-6. Cushion	
2-7. Directional control	
2-8. Auto switch	
3. Maintenance	P18
3-1. Checks	
3-2. Replacement of seals	
3-3. Consumable parts	
3-4. Troubleshooting	
4. Basic Circuit for Clamp Cylinder Operation	P24
5. Construction	P25



# Safety Instructions

These safety instructions are intended to prevent hazardous situations and/or equipment damage. These instructions indicate the level of potential hazard with the labels of “**Caution**,” “**Warning**” or “**Danger**.” They are all important notes for safety and must be followed in addition to International Standards (ISO/IEC)\*1), and other safety regulations.

\*1) ISO 4414: Pneumatic fluid power - General rules and safety requirements for systems and their components  
ISO 4413: Hydraulic fluid power - General rules and safety requirements for systems and their components  
IEC 60204-1: Safety of machinery - Electrical equipment of machines - Part 1: General requirements  
ISO 10218-1: Robots and robotic devices - Safety requirements for industrial robots - Part 1: Robots  
etc.



## **Danger**

**Danger** indicates a hazard with a high level of risk which, if not avoided, will result in death or serious injury.



## **Warning**

**Warning** indicates a hazard with a medium level of risk which, if not avoided, could result in death or serious injury.



## **Caution**

**Caution** indicates a hazard with a low level of risk which, if not avoided, could result in minor or moderate injury.



## **Warning**

### **1. The compatibility of the product is the responsibility of the person who designs the equipment or decides its specifications.**

Since the product specified here is used under various operating conditions, its compatibility with specific equipment must be decided by the person who designs the equipment or decides its specifications based on necessary analysis and test results. The expected performance and safety assurance of the equipment will be the responsibility of the person who has determined its compatibility with the product. This person should also continuously review all specifications of the product referring to its latest catalog information, with a view to giving due consideration to any possibility of equipment failure when configuring the equipment.

### **2. Only personnel with appropriate training should operate machinery and equipment.**

The product specified here may become unsafe if handled incorrectly. The assembly, operation and maintenance of machines or equipment including our products must be performed by an operator who is appropriately trained and experienced.

### **3. Do not service or attempt to remove product and machinery/equipment until safety is confirmed.**

1. The inspection and maintenance of machinery/equipment should only be performed after measures to prevent falling or runaway of the driven objects have been confirmed.
2. When the product is to be removed, confirm that the safety measures as mentioned above are implemented and the power from any appropriate source is cut, and read and understand the specific product precautions of all relevant products carefully.
3. Before machinery/equipment is restarted, take measures to prevent unexpected operation and malfunction.

### **4. Our products cannot be used beyond their specifications. Our products are not developed, designed, and manufactured to be used under the following conditions or environments. Use under such conditions or environments is not covered.**

1. Conditions and environments outside of the given specifications, or use outdoors or in a place exposed to direct sunlight.
2. Use for nuclear power, railways, aviation, space equipment, ships, vehicles, military application, equipment affecting human life, body, and property, fuel equipment, entertainment equipment, emergency shut-off circuits, press clutches, brake circuits, safety equipment, etc., and use for applications that do not conform to standard specifications such as catalogs and operation manuals.
3. Use for interlock circuits, except for use with double interlock such as installing a mechanical protection function in case of failure. Please periodically inspect the product to confirm that the product is operating properly.



# Safety Instructions

## Caution

**We develop, design, and manufacture our products to be used for automatic control equipment, and provide them for peaceful use in manufacturing industries.**

**Use in non-manufacturing industries is not covered.**

Products we manufacture and sell cannot be used for the purpose of transactions or certification specified in the Measurement Act.

The new Measurement Act prohibits use of any unit other than SI units in Japan.

## Limited warranty and Disclaimer/Compliance Requirements

The product used is subject to the following “Limited warranty and Disclaimer” and “Compliance Requirements”. Read and accept them before using the product.

### Limited warranty and Disclaimer

1. The warranty period of the product is 1 year in service or 1.5 years after the product is delivered, whichever is first.\*2)  
Also, the product may have specified durability, running distance or replacement parts. Please consult your nearest sales branch.
2. For any failure or damage reported within the warranty period which is clearly our responsibility, a replacement product or necessary parts will be provided.  
This limited warranty applies only to our product independently, and not to any other damage incurred due to the failure of the product.
3. Prior to using SMC products, please read and understand the warranty terms and disclaimers noted in the specified catalog for the particular products.

**\*2) Vacuum pads are excluded from this 1 year warranty.**

A vacuum pad is a consumable part, so it is warranted for a year after it is delivered.

Also, even within the warranty period, the wear of a product due to the use of the vacuum pad or failure due to the deterioration of rubber material are not covered by the limited warranty

### Compliance Requirements

1. The use of SMC products with production equipment for the manufacture of weapons of mass destruction (WMD) or any other weapon is strictly prohibited.
2. The exports of SMC products or technology from one country to another are governed by the relevant security laws and regulations of the countries involved in the transaction. Prior to the shipment of a SMC product to another country, assure that all local rules governing that export are known and followed.

# 1. Specifications

## 1-1. Specifications

Fluid	Air
Proof pressure	1.5 MPa
Max. operating pressure	1.0 MPa
Min. operating pressure	0.05 MPa
Ambient and fluid temperature	Without auto switch: -10 to 70°C With auto switch: -10 to 60°C (No freezing)
Lubrication	Non-lube
Stroke length tolerance	+1.4 0 mm
Cushion	Unclamping side (head side): With air cushion
Speed controller	At both ends
Piston speed	50 to 500 mm/sec

### Warning

- **Confirm the specifications.**

The product is designed only for use in industrial compressed air systems. Do not operate at pressures, temperatures or kinetic energy beyond the range of specifications, as this can cause damage or malfunction.

(Refer to the specifications.)

# 2. Installation and Handling

## 2-1. Air supply

The compressed air supplied to the cylinder should be filtered by SMC AF series air filter and regulated to the specified set pressure by SMC AR series regulator.

### Warning

- **Use clean air.**

Do not use compressed air which contains chemicals, synthetic oils containing organic solvents, salts or corrosive gases, etc., as this can cause damage or malfunction.

### Caution

- **Install an air filter.**

Install an air filter upstream near the valve. Select an air filter with a filtration size of 5µm or smaller.

- **Take appropriate measures to ensure air quality, such as providing an aftercooler, air dryer, or water separator.**

Compressed air that contains a large amount of moisture can cause the malfunction of pneumatic equipment such as valves. Therefore, take appropriate measures to ensure air quality, such as providing an aftercooler, air dryer, or water separator.

- **Ensure that the fluid and ambient temperature are within the specified range.**

When operating at temperatures below 5°C, water in the circuit may freeze and cause breakage of seals or malfunction. Corrective measures should be taken to prevent freezing.

For compressed air quality, refer to Best Pneumatics No.5.

- **No lubrication is required.**

## 2-2. Design

The compatibility of the product is the responsibility of the person who designs the equipment or decides its specifications.

### **Warning**

- **There is a possibility of dangerous sudden action by air cylinders if sliding parts of machinery are twisted due to external forces, etc.**  
In such cases, injury may occur, such as hands or feet getting caught in the machinery, or damage to the machinery itself may occur. Design the machinery to avoid such dangers.
- **A protective cover is recommended to minimize the risk of personal injury.**  
If the moving portion of the product will pose a hazard to humans or will damage machinery or equipment, provide a construction that prevents direct contact with those areas.
- **Securely tighten all stationary parts and connected parts so that they will not become loose.**  
Do not use the product where operation frequency is high or the product is exposed to vibration.
- **Design the system so that it will not apply an external force over the maximum force to the product.**  
The product can break, causing a risk of injury or damage to equipment.
- **The product generates a large force. Install on a sufficiently rigid mounting base, taking this force into consideration.**  
There is a risk of injury or damage to equipment.
- **Consider the possibility of a reduction in the circuit air pressure caused by a power failure.**  
When a cylinder is used in a clamping mechanism, the work piece may come off due to a decrease in clamping force because of a decrease in the circuit pressure caused by a power failure, etc. Therefore, safety equipment should be installed to prevent damage to machinery and injury. Suspension equipment and lifting devices also require measures to prevent dropping.
- **Consider a possible loss of power source.**  
Measures should be taken to prevent injury and equipment damage in the event that there is a loss of power to equipment controlled by air pressure, electricity or hydraulics, etc.
- **Consider the behavior of the rotary actuator in the event of an emergency stop.**  
Devise a safety system so that if a person engages the emergency stop, or if a safety device is tripped during a system malfunction such as a power outage, the movement of the cylinder will not cause a hazard to humans or damage the equipment.
- **Consider the action when operation is restarted after an emergency stop or abnormal stop.**  
Design the machinery so that injury or equipment damage will not occur upon restart of operation. When the cylinder has to be reset at the starting position, install manual safety equipment.
- **Intermediate stop**  
It is difficult for this product to make a piston stop at the required intermediate position accurately and precisely using a 3 position closed center type directional control valve, due to the compressibility of air. Furthermore, since valves and cylinders are not guaranteed for zero air leakage, it may not be possible to hold a stopped position for extended periods of time.

### **Caution**

- **Do not touch the cylinder during high speed and high frequency operation of the cylinder.**  
When the cylinder is operating at a high speed and high frequency, the cylinder tube surface temperature increases, and may cause a burn.
- **Do not use the air cylinder as an air-hydro cylinder.**  
If working fluid of the air cylinder is turbine oil, oil leakage can result.
- **Grease is applied to cylinder.**
- **The base oil of grease may seep out.**  
The base oil of grease in the cylinder may seep out of the tube, cover, crimped part or rod bushing depending on the operating conditions (ambient temperature 40 °C or more, pressurized condition, low frequency operation).

## 2-3. Mounting and Installation

- 1) The cylinder should be mounted so that the load is always applied to the piston rod in the axial direction.

For rotational operation, match the rotating direction of the rod cover and workpiece, and mount the product without causing twisting.

- 2) Make sure to flush inside the piping with air before installing to remove foreign matter. Filter removes foreign matter such as dust and scaling inside the piping before the filter, but not after the filter. Foreign matter after the filter enters directly into the solenoid valve and cylinder, reducing the product life.
- 3) When the product is installed on a machine on site, the debris from drilled mounting holes can get in the supply port of the product. Take sufficient care to prevent this.
- 4) Avoid scratches on the external circumference of the piston rod, which is a sliding part of the cylinder.

It may cause operation failure, or air leakage, etc. due to damage to the rod seal.

Scratches or dents to the external and internal circumference of the cylinder tube may cause operation failure, and air leakage, etc. due to damage to the piston seal.

- 5) 3 piping port directions are available.

When changing the port direction, unplug the port to be used, and reuse the port plug with the appropriate amount of sealant in the original port. Before plugging, perform flushing sufficiently to prevent foreign matter such as sealant and dust from entering the cylinder.

### **Caution**

- **Be sure to connect the piston rod and the load so that their axial centers and movement directions match.**

If they do not match, stress could be applied to the rod and the cylinder tube, causing the inner surface of the cylinder tube, the bushing, the rod surface, and the seals to wear and become damaged.

- **When an external guide is used, connect the piston rod end and the load in such a way that there is no interference at any point within the stroke.**

- **Do not apply excessive lateral load to the piston rod.**

- **Prevent the seizure of rotating parts.**

Prevent the seizure of rotating parts (pins, etc.) by applying grease.

- **Do not use the product until you have verified that the equipment can operate properly.**

After installation or repair, apply air and power supplies to the equipment and perform appropriate functional and leakage inspections to make sure the equipment is mounted properly.

## 2-4. Environment

### **Warning**

- **Do not use in environments where there is a danger of corrosion.**
- **Install a cover over the rod if it is used in an area that is dusty, or in an environment in which water or oil splashes on the cylinder.**
- **Avoid storing the product in humid conditions.**

Store the product with the piston rod retracted and avoid humidity, in order to prevent generation of rust.

## **Caution**

- **Preparation before piping**

Before piping, perform air blow (flushing) or cleaning to remove any cutting chips, cutting oil, dust, etc. from the piping and fitting.

- **Wrapping of pipe tape**

When screwing piping or fittings into ports, ensure that chips from the pipe threads or sealing material do not enter the piping.

Also, if pipe tape is used, leave 1.5 to 2 thread ridges exposed at the end of the threads.

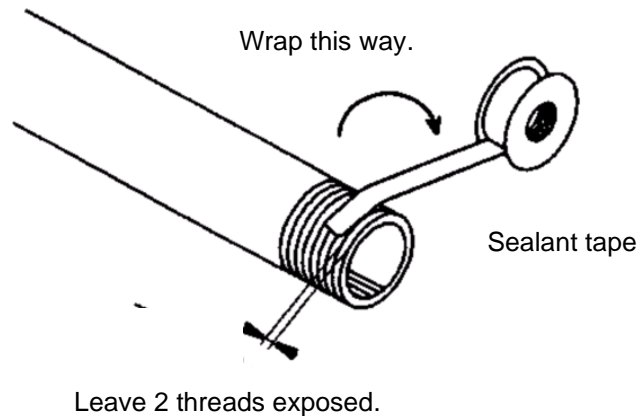

**Fig. 1 Sealant tape**

## **2-5. Speed control**

- 1) CK1 series cylinder has built-in speed controllers (exhaust throttle mechanism) on rod side and head side.

As the speed controllers have no check mechanism but throttle mechanism only, the maximum adjustable speed ratio between the clamping side and unclamping side is 1:4.

- 2) The cylinder is adjusted to control speed appropriately before exiting the factory, but the speed controller valve (marked with S on the rod cover) can be adjusted on the cover according to the operating speed and size of the load.
- 3) Speed controller valve reduces the cylinder speed when it is rotated in the clockwise direction with a smaller orifice, and increases speed when it is rotated in the counter-clockwise direction with a larger orifice.

## **Warning**

- **Speed controller valve is crimped. Do not rotate the speed controller valve for more than 4.5 turns (Ø40:2 turns).**



## 2-6. Cushion

- 1) CK1 series cylinder had a built-in air cushion on the head side.
- 2) Cylinder cushion is adjusted properly before exiting the factory, but the cushion valve on the tube cover can be adjusted according to the working load and operating speed.
- 3) When the cushion valve is turned in the clockwise direction, the orifice becomes smaller and the cushion effectiveness is increased. When the cushion valve is turned in the counter-clockwise direction, the orifice becomes larger and the cushion effectiveness is reduced.
- 4) Cushion seal is subject to wear and cushion effectiveness changes in the product operation for an extended period of time. Readjust the cushion as necessary.
- 5) If the cushion valve is fully closed, the piston may bounce at the end of stroke and not move through the full stroke, or the cushion seal may be damaged due to excessive pressure. Do not fully close the cushion valve.

### Warning

- **Cushion valve is crimped. Do not rotate the cushion valve for more than 2.0 turns.**

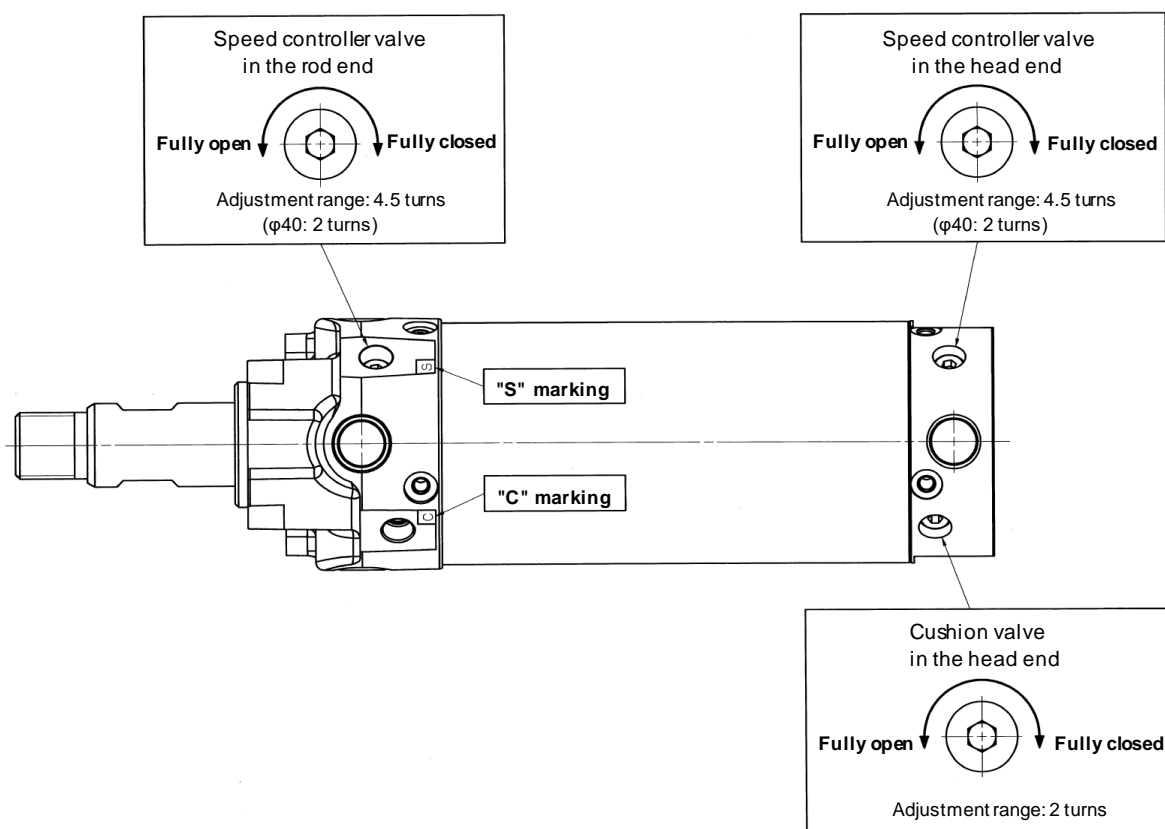

**Fig. 2 Adjustment of speed controller and cushion**

## 2-7. Directional control

To switch the operating direction of the cylinder, mount an applicable solenoid valve selected from SMC's range of solenoid valves.

For improved safety, double solenoid type valve is recommended.

### Warning

- Design a circuit to prevent sudden action of a driven object.

When the product is actuated by an exhaust center type directional control valve or when one side of the piston is pressurized with air exhaust on the other side, which can occur when the product is started after the exhaust of the residual pressure from the circuit, driven objects may act suddenly at high speed. In such cases, injury may occur, such as hands or feet getting caught in the machinery, or damage to the machinery itself. Design the machinery to avoid such dangers.

## 2-8. Auto switch

### Magnetic field resistant auto switch

On the standard built-in magnet clamp cylinder CKG1 series and the strong magnet built-in clamp cylinder CKP1 series, it is possible to install the magnetic field resistant auto switches listed in the table below.

**Applicable Magnetic Field Resistant Auto Switches/** Refer to the Web Catalog for detailed auto switch specifications.

Type	Rod mounting	Band mounting	Auto switch model	Applicable magnetic field	Electrical entry	Indicator light	Wiring (Pin no. in use)	Load voltage	Lead wire length	Applicable load
Solid state auto switch	●	—	D-P3DWASC	AC magnetic field (Single-phase AC welding magnetic field)	Pre-wired connector	2-color indicator	2-wire (3-4)	24 VDC	0.3 m	Relay, PLC
	●	—	D-P3DWASE				2-wire (1-4)			
	●	—	D-P3DWA		Grommet		2-wire		3 m	
	●	—	D-P3DWAL						5 m	
	●	—	D-P3DWAZ		Pre-wired connector		2-wire (3-4)		0.3 m	
	●	●	D-P4DWSC							
	●	●	D-P4DWSE		Grommet		2-wire		3 m	
	●	●	D-P4DWL						5 m	
●	●	D-P4DWZ								

Type	Auto switch model	Applicable magnetic field	Electrical entry	Indicator light	Wiring (Pin no. in use)	Load voltage	Lead wire length	Applicable load
Reed auto switch	D-P79WSE	DC/AC magnetic field	Pre-wired connector	2-color indicator	2-wire (1-4)	24 VDC	0.3 m	Relay, PLC
	D-P74L		Grommet	1-color indicator	2-wire	24 VDC 100 VAC	3 m	
	D-P74Z						5 m	

\* PLC: Programmable Logic Controller.

\* As for the D-P4DW□ type, band mounting type, the auto switch mounting bracket and the auto switch have to be ordered separately. For details, refer to page 13.

### Standard Auto Switches

On the standard built-in magnet clamp cylinder CKG1 series, it is possible to install the standard auto switches listed in the table below.

 Standard auto switches cannot be used under a strong magnetic field.

Type	Special function	Electrical entry	Indicator light	Wiring (Output)	Load voltage		Auto switch model	Lead wire length [m]				Pre-wired connector	Applicable load	
					DC	AC		0.5 (Nil)	1 (M)	3 (L)	5 (Z)			
Solid state auto switch	—	Grommet	Yes	3-wire (NPN)	24 V	—	M9N	●	●	●	○	○	IC circuit	
				3-wire (PNP)			M9P	●	●	●	○	○		
				2-wire			M9B	●	●	●	○	○		
				3-wire (NPN)			M9NW	●	●	●	○	○		
				3-wire (PNP)			M9PW	●	●	●	○	○		
				2-wire			M9BW	●	●	●	○	○		
	Diagnostic indication (2-color indicator)	Water resistant (2-color indicator)	Grommet	Yes	3-wire (NPN)	24 V	—	M9NA	○	○	●	○	○	IC circuit
					3-wire (PNP)			M9PA	○	○	●	○	○	
					2-wire			M9BA	○	○	●	○	○	
					2-wire			M9BA	○	○	●	○	○	
Reed auto switch	—	Grommet	Yes	3-wire (NPN equivalent)	24 V	—	A96	●	—	●	—	—	IC circuit	
				2-wire			A93	●	●	●	●	—		—
							A90	●	—	●	—	—		

\* Solid state auto switches marked with a "○" are produced upon receipt of order  
 \* Auto switches and mounting brackets are shipped together with the product but do not come assembled.  
 \* For the standard magnet type (CKG1), auto switches other than those described above cannot be used.

\* Lead wire length symbols: 0.5 m.....Nil (Example) M9NWV  
 1 m.....M (Example) M9NWVM  
 3 m.....L (Example) M9NWVL  
 5 m.....Z (Example) M9NWVZ

## Auto Switch Proper Mounting Position (Detection at stroke end) and Mounting Height

### D-P3DWA□

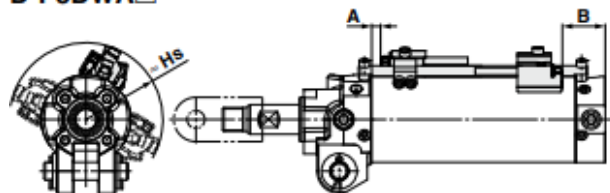

### D-P4DW□

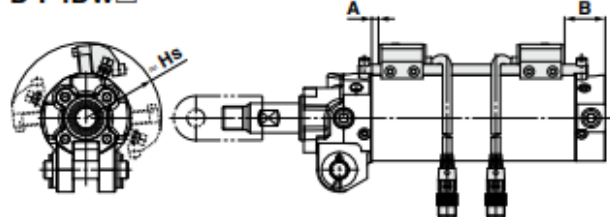

\* The above drawing is the switch rod mounting example for the D-P4DWS□.

### D-P79WSE

### D-P74□

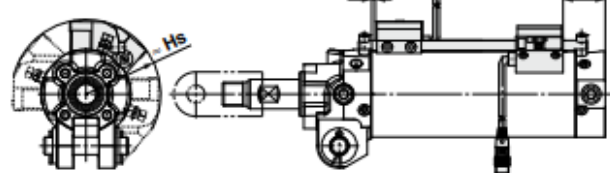

\* The above drawing is the switch rod mounting example for the D-P79WSE.

### D-M9□/M9□W

### D-M9□A/A9□

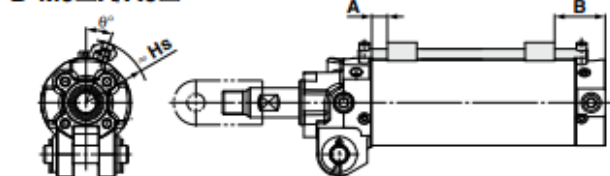

### CKG1 (Standard magnet type)

Unit: mm

Auto switch model	Symbol	Auto switch set value and mounting height		
		ø40	ø50	ø63
D-P3DWA□	A	6.5	8	8
	B	25.5	27	27
	Hs	46.5	52	59
D-P4DW□	A	4	5.5	5.5
	B	23	24.5	24.5
	Hs	45.5	51	58.5
D-M9□ D-M9□W D-M9□A	A	11	12.5	12.5
	B	30	31.5	31.5
	Hs	39	44.5	51.5
D-A9□	A	7	8.5	8.5
	B	26	27.5	27.5
	Hs	39	44.5	51.5

### CKP1 (Strong magnet type)

Unit: mm

Auto switch model	Symbol	Auto switch set value and mounting height		
		ø40	ø50	ø63
D-P79WSE D-P74□	A	0	0	0
	B	26	27	27
	Hs	47.5	51	57.5

\* The mounting position should be referred for reference only for the auto switch mounting position at the stroke end detection. Adjust the auto switch after confirming the operation to set actually.

\* In the case of a 2-color indicator auto switch, mount it at the center of the green LED illuminating range.

However, pay attention that for D-P79WSE the green indicator light will not be illuminated when used close to the edge of the rod end.

\* Adjust the auto switch after confirming the operating conditions in the actual setting

## Minimum Stroke for Auto Switch Mounting

Unit: mm

Auto switch model	With 1 pc.	With 2 pcs.	
		Different surfaces	Same surface
D-P3DWA□	50	50	50
D-P4DW□			
D-P79WSE			
D-P74□			

\* When two D-P3DWA□ are mounted to the cylinder with stroke 50 mm, mount them on different surfaces.

\* The standard strokes of CKG1 are 50, 75, 100, 125, and 150 mm.

The values in the table above are not based on the minimum detection interval when setting the D-P3DWA auto switch, but on the standard minimum stroke of the cylinder.

## Operating Range

Unit: mm

Auto switch model	Bore size		
	40	50	63
D-P3DWA□	5.5	5.5	5.5
D-P4DW□	4	4	4.5
D-P79WSE	8	9	9.5
D-P74□			
D-M9□ D-M9□W D-M9□A	4	4.5	5
D-A9□	8	8	9

\* Values which include hysteresis are for reference purposes only. They are not a guarantee (assuming approximately ±30% dispersion) and may change substantially depending on the ambient environment.

## Auto Switch Mounting Brackets/Part Nos.

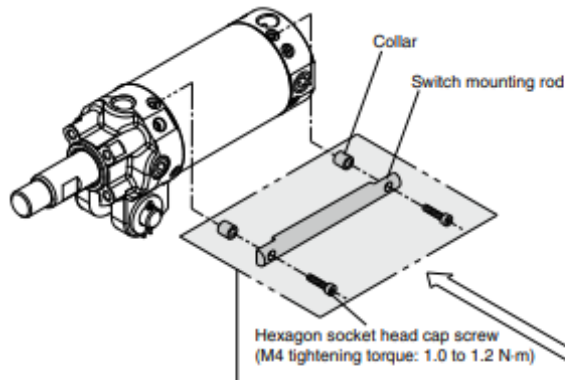

### Auto Switch Mounting Rod Assembly/Part Nos. CKG1 Series

Bore size (mm)	Cylinder stroke (mm)	Part no.
40	50	CKG40-RZ050A
	75	CKG40-RZ075A
	100	CKG40-RZ100A
	125	CKG40-RZ125A
50, 63	150	CKG40-RZ150A
	50	CKG50-RZ050A
	75	CKG50-RZ075A
	100	CKG50-RZ100A
50, 63	125	CKG50-RZ125A
	150	CKG50-RZ150A
	200	CKG50-RZ200A

### CKP1 Series

Bore size (mm)	Cylinder stroke (mm)	Part no.
40	50	CKP50-RZ050A
	75	CKP50-RZ075A
	100	CKP50-RZ100A
	125	CKP50-RZ125A
50, 63	150	CKP50-RZ150A
	50	CKP50-RZ050A
	75	CKP50-RZ075A
	100	CKP50-RZ100A
50, 63	125	CKP50-RZ125A
	150	CKP50-RZ150A
	200	CKP50-RZ200A

### D-M9□/M9□W D-M9□A/A9□

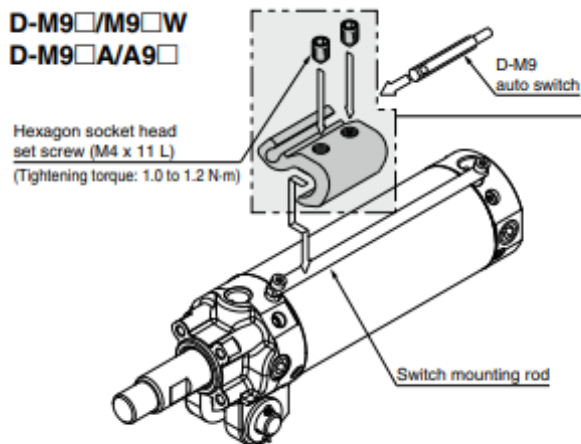

### D-P4DW□ D-P79W□\*1 D-P74

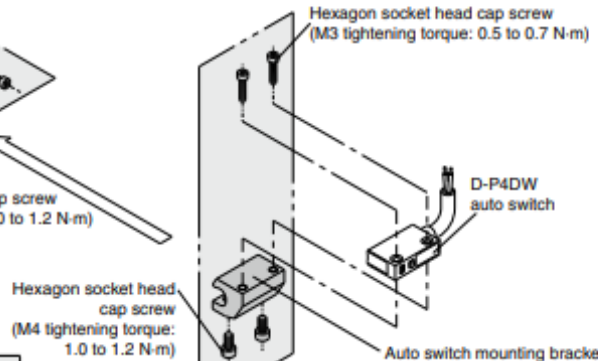

\*1 For the D-P79W□, face the soft-resin mold surface to the switch mounting bracket side for mounting.

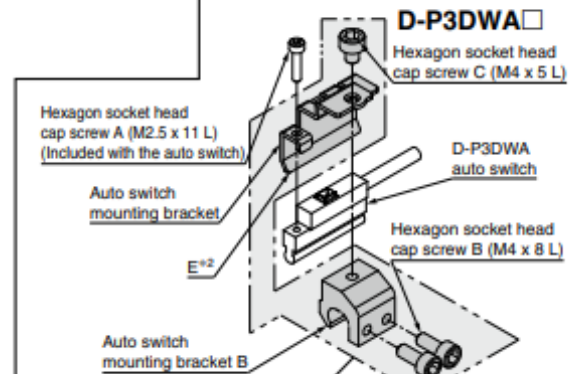

\*2 Mount the part E of the auto switch mounting bracket so that it is in contact with the cylinder tube.

\* The tightening torque for the hexagon socket head cap screw A (M2.5) is 0.2 to 0.3 N·m. Hold the shorter side of a hexagon wrench, and turn it to tighten. (Too much tightening may break the switch.)

\* Tighten the hexagon socket head cap screws B and C (M4) with a tightening torque of 1 to 1.2 N·m.

### Auto Switch Mounting Brackets/Part Nos.

Applicable cylinder	Applicable auto switch	Part no.		
		φ40	φ50	φ63
CKG1	D-P3DWA□	BK7-040S		
	D-P4DW□	BK1T-040		
	D-M9□ D-A9□	BA7-040		
CKP1	D-P79WSE D-P74L/Z	BAP1T-040		

## Auto Switch Mounting (Band Mounting)

### Auto Switch Proper Mounting Position (Detection at stroke end) and Mounting Height

#### D-P4DW□

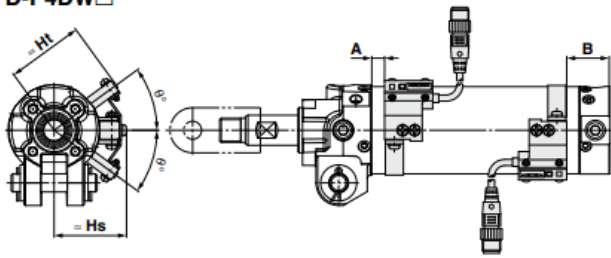

\* The above drawing is the switch band mounting example for the D-P4DWS□.

#### D-M9□/M9□W D-M9□A/A9□

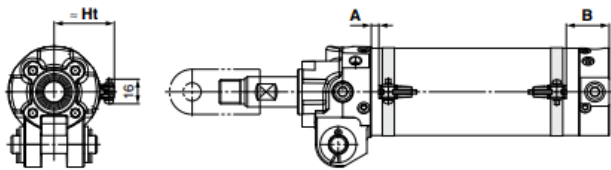

### ⚠ Caution

As for the precautions on the auto switches, product specifications, refer to pages 16 and 17.

### Operating Range

Auto switch model	Bore size		
	40	50	63
D-P4DW□	5	5	5.5
D-M9□ D-M9□W D-M9□A	5.5	6.5	7
D-A9□	8	8	9

\* Values which include hysteresis are for reference purposes only. They are not a guarantee (assuming approximately ±30% dispersion) and may change substantially depending on the ambient environment.

### CKG1 (Standard magnet type)

Unit: mm

Auto switch model	Symbol	Auto switch set value and mounting height		
		ø40	ø50	ø63
D-P4DW□	A	4	5.5	5.5
	B	23	24.5	24.5
	Hs	43	48	55
	Ht	46	51.5	58.5
	θ	40	36	33
D-M9□ D-M9□W D-M9□A	A	11	12.5	12.5
	B	30	31.5	31.5
	Hs	35	40.5	47.5
D-A9□	A	7	8.5	8.5
	B	26	27.5	27.5
	Hs	35	40.5	47.5

- \* The mounting position should be referred for reference only for the auto switch mounting position at the stroke end detection. Adjust the auto switch after confirming the operation to set actually.
- \* The auto switch mounting position is temporarily set at the time of shipping from our factory. Change it to the desired position in accordance to your facility.
- \* For the D-M9□, M9□W, M9□A, A9□, A and B are the dimensions from the end of the head cover/rod cover to the end of the auto switch.
- \* As for the D-P4DW□ type, band mounting type, the auto switch mounting bracket and the auto switch have to be ordered separately. For details, refer to page 13.
- \* In the case of a 2-color indicator auto switch, mount it at the center of the green LED illuminating range.

### Minimum Stroke for Auto Switch Mounting

Unit: mm

Auto switch model	With 1 pc.	With 2 pcs.	
		Different surfaces	Same surface
D-P4DW□	50	50	50
D-M9□ D-M9□W D-M9□A			
D-A9□			

## Auto Switch Mounting Brackets/Part Nos.

Auto switch model	Bore size [mm]		
	40	50	63
D-P4DW□	BA8-040	BA8-050	BA8-063

Auto switch model	Bore size [mm]		
	40	50	63
D-M9□ D-M9□W D-A9□	BMA3-040*1 (A set of a, b, c, d)	BMA3-050*1 (A set of a, b, c, d)	BMA3-063*1 (A set of a, b, c, d)
D-M9□A*2	BMA3-040S (A set of b, c, e, f)	BMA3-050S (A set of b, c, e, f)	BMA3-063S (A set of b, c, e, f)

\*1. The switch brackets (made of polyamide) may not be subject to splashing chemicals as they might damage the brackets, compromising their performance. (Alcohol, Chloroform, Methylamine, Hydrochloric acid, Sulfuric acid, etc)

\*2. When mounting a D-M9□A type auto switch, if the switch bracket is mounted on the indicator light, it may damage the auto switch. Therefore, be sure to avoid mounting the switch bracket on the indicator light.

# Auto Switch Connections and Examples

## Sink Input Specifications

### 3-wire, NPN

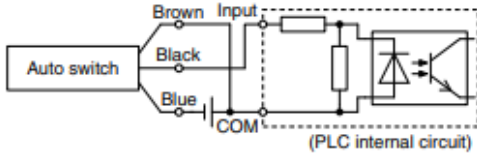

### 2-wire

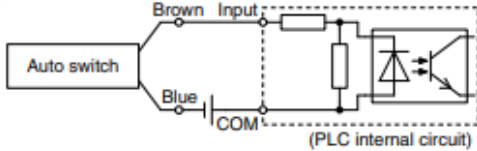

## Source Input Specifications

### 3-wire, PNP

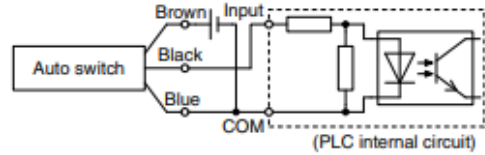

### 2-wire

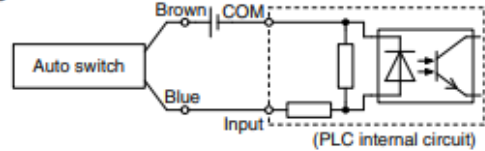

Connect according to the applicable PLC input specifications, as the connection method will vary depending on the PLC input specifications.

## Examples of AND (Series) and OR (Parallel) Connections

\* When using solid state auto switches, ensure the application is set up so the signals for the first 50 ms are invalid. Depending on the operating environment, the product may not operate properly.

### 3-wire AND connection for NPN output

(Using relays)

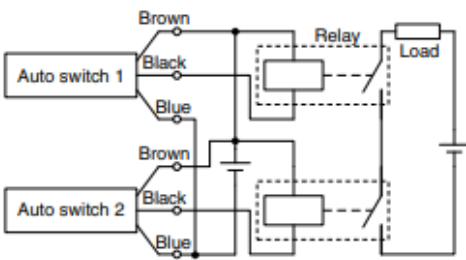

(Performed with auto switches only)

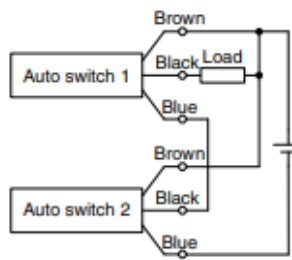

### 3-wire OR connection for NPN output

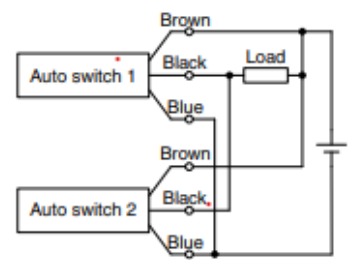

### 3-wire AND connection for PNP output

(Using relays)

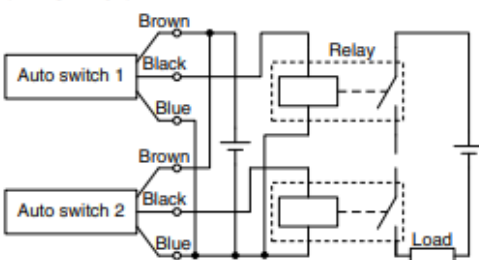

(Performed with auto switches only)

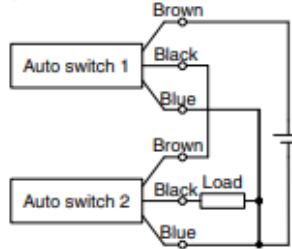

### 3-wire OR connection for PNP output

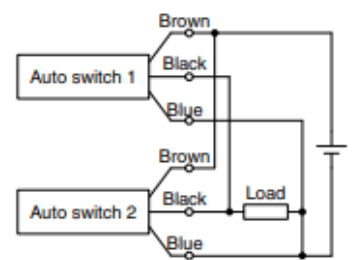

### 2-wire AND connection

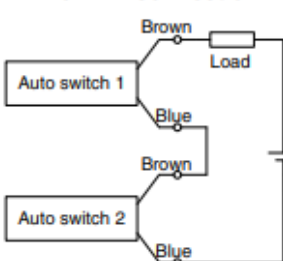

When two auto switches are connected in series, a load may malfunction because the load voltage will decline when in the ON state. The indicator lights will light up when both of the auto switches are in the ON state. Auto switches with a load voltage less than 20 V cannot be used. Please contact SMC if using AND connection for a heat-resistant solid state auto switch or a trimmer switch.

Example) Load voltage at ON  
 Power supply voltage: 24 VDC  
 Internal voltage drop: 4 V  
 Load voltage at ON = Power supply voltage -  
 Internal voltage drop x 2 pcs.  
 = 24 V - 4 V x 2 pcs.  
 = 16 V

### 2-wire OR connection

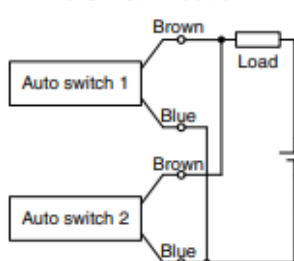

(Solid state)  
 When two auto switches are connected in parallel, malfunction may occur because the load voltage will increase when in the OFF state.

(Reed)  
 Because there is no current leakage, the load voltage will not increase when turned OFF. However, depending on the number of auto switches in the ON state, the indicator lights may sometimes grow dim or not light up, due to the dispersion and reduction of the current flowing to the auto switches.

Example) Load voltage at OFF  
 Leakage current: 1 mA  
 Load impedance: 3 kΩ  
 Load voltage at OFF = Leakage current x 2 pcs. x  
 Load impedance  
 = 1 mA x 2 pcs. x 3 kΩ  
 = 6 V

# Piping Port / Switch Mounting Rod Location Change

## Piping Port Location Change

Piping is possible from 3 directions. When the piping port location is changed, carefully follow the instructions as detailed below.

### Warning

- Do not leave out the component parts when the piping port location is changed.  
Even if one of the component parts is kept away, malfunction may occur, resulting in dangerous operation.
- To prevent air leakage, re-wind the pipe tape and fit into the changed location when the piping port location is changed.

## Switch Mounting Rod Location Change

The switch mounting rod is mountable from 3 directions. When the switch mounting rod is changed, carefully follow the instruction as detailed below.

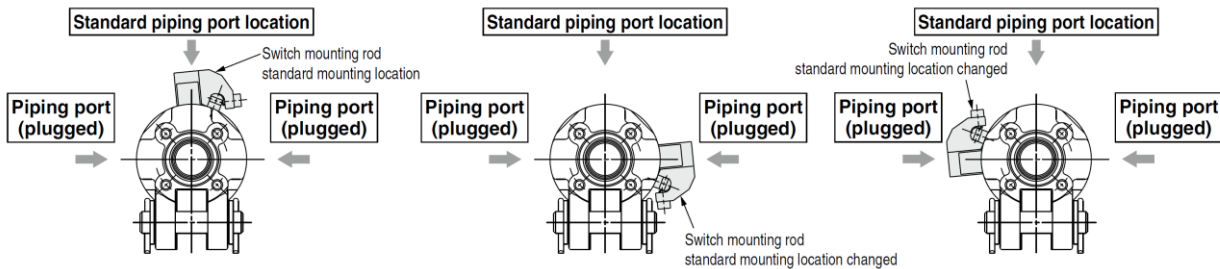

### Warning

- Mount all the component parts to the changed location.  
Even if one of the component parts is kept away, the switch detection error etc. may occur. (Switch mounting rod, switch mounting spacer, hexagon socket head cap screw)
- After the switch mounting rod location is changed, confirm that there is no interference with other parts before use.

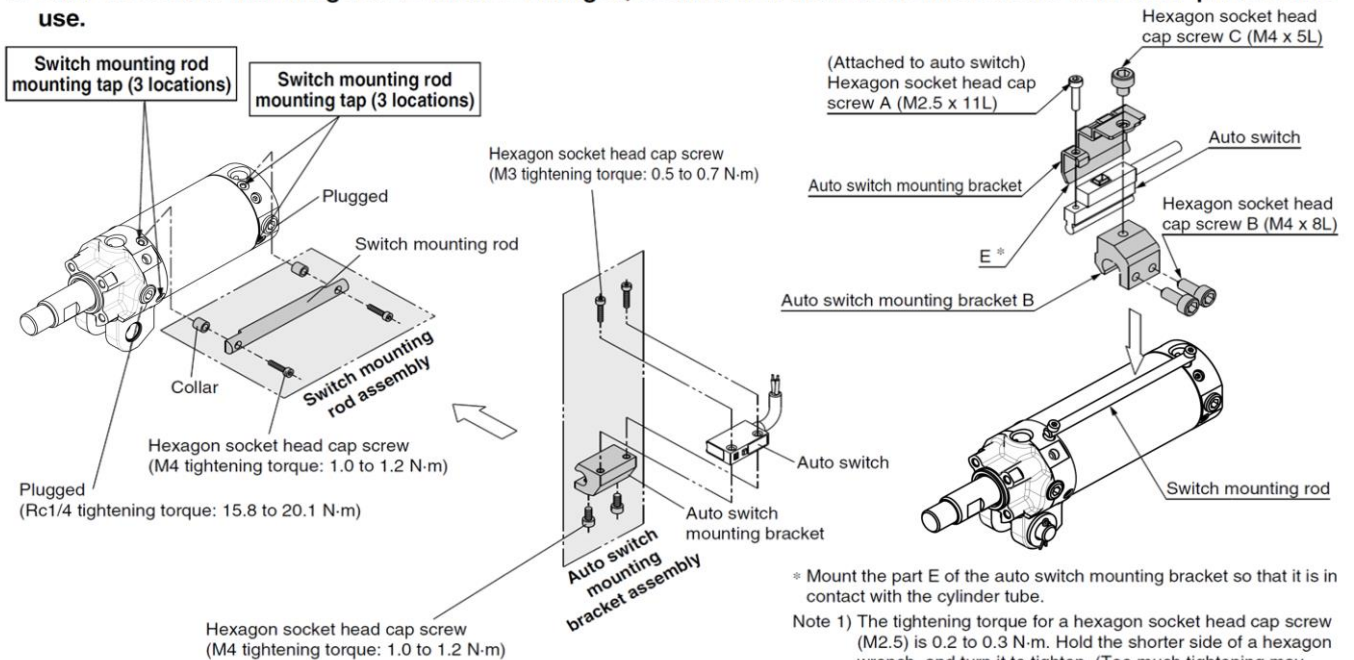

- ※ Mount the part E of the auto switch mounting bracket so that it is in contact with the cylinder tube.
- Note 1) The tightening torque for a hexagon socket head cap screw (M2.5) is 0.2 to 0.3 N-m. Hold the shorter side of a hexagon wrench, and turn it to tighten. (Too much tightening may break the switch)
- Note 2) Tighten the hexagon socket head cap screws B and C (M4) with a tightening torque of 1 to 1.2 N-m.



## Handling

Magnetic field resistant auto switches D-P79WSE/ D-P74□ are specifically for use with strong magnet type cylinders and are not compatible with general auto switches or cylinders. Strong magnet type cylinders are labeled as follows.

Magnetic field resistant cylinder with built-in magnet  
(For use with auto switch D-P7)

## Mounting

1. The minimum stroke for mounting magnetic field resistant auto switches is 50 mm.
2. In order to fully use the capacity of magnetic field resistant auto switches, strictly observe the following precautions.
  - 1) Do not allow the magnetic field to occur when the cylinder piston is moving.
  - 2) When a welding cable or welding gun electrodes are near the cylinder, change the auto switch position to fall within the operational ranges shown in the graphs on page 17, or move the welding cable away from the cylinder.
  - 3) Cannot be used in an environment where welding cables surround the cylinder.
  - 4) If multiple objects that generate a magnetic field (such as a welding cable and a welding gun electrode) move close to an auto switch, the closest they are allowed to be to the auto switch can be calculated by multiplying the safety distance by the number of elements.
3. In an environment where spatter directly hits the lead wire, cover the lead wire with protective tubing.

Use protective tubing with inside diameter of  $\varnothing 8$  or more that has excellent heat resistance and flexibility.
4. Be careful not to drop objects, make dents, or apply excessive impact force when handling.
5. When operating two or more cylinders with magnetic field resistant auto switches in parallel and proximity, separate the auto switches from other cylinder tubes by an additional 30 mm or more.
6. Avoid wiring in a manner in which repeated bending stress or tension is applied to lead wires.
7. Be careful of the mounting direction of the magnetic field resistant auto switch D-P79WSE. Be sure to face the soft-resin mold surface to the switch mounting bracket side for mounting. (Refer to Web Catalog for soft-resin mold surface.)

# Magnetic Field Resistant Reed Auto Switches (D-P79WSE, D-P74□) Safety Distance

## Safety Distance from Side of Auto Switch

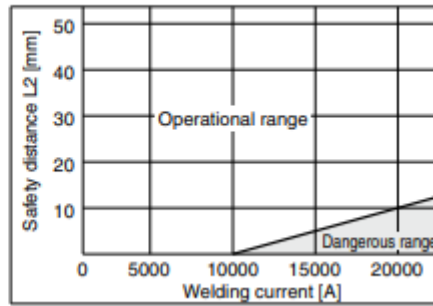
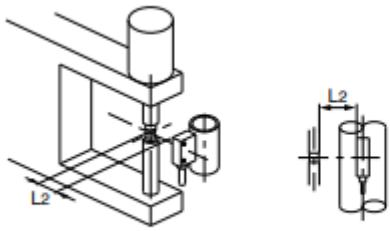
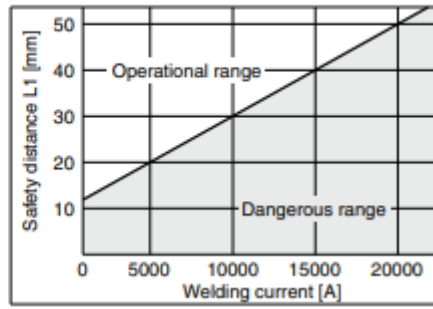
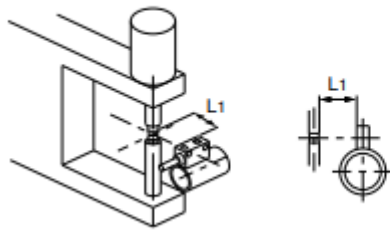

## Safety Distance from Top of Auto Switch

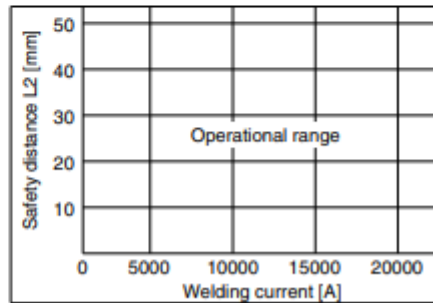
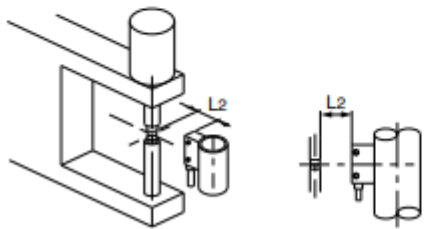
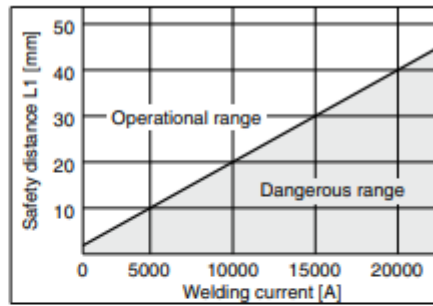
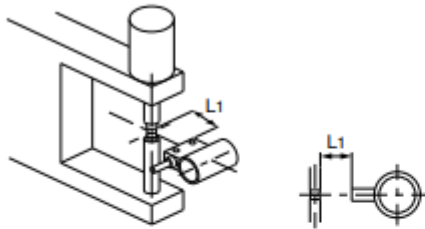

## 3. Maintenance

### 3-1. Checks

The following checks are required for proper cylinder operation.

- 1) Smooth operation
- 2) Changes in piston speed and cycle time.
- 3) Abnormal stroke
- 4) Looseness of mounting frame and excessive deflection
- 5) Internal and external leakage (Change in output)
- 6) Damage to the piston rod sliding surface
- 7) Clogging and discharge drainage of the air filter
- 8) Lubrication of rotating parts (double knuckle joint, pin, etc.)
- 9) Position of auto switches

When any abnormality is found as a result of checking the points above, eliminate causes and take necessary measures such as retightening screws and applying grease.

#### **Warning**

- **At a minimum, maintenance should be performed according to the above items. Perform additional maintenance as necessary.**

Improper handling can cause damage and malfunction of equipment and machinery.

- **Removal of equipment, and supply/exhaust of compressed air.**

Ensure that drop prevention measures and safe lock out of the moving parts are taken, the power of the facility and supply air is shut off and the compressed air in the system is exhausted before removing the equipment.

Before restarting the equipment, confirm that measures are taken to prevent sudden action.

### 3-2. Replacement of seals

For  $\varnothing 40$ , the rod seal, piston seal and tube gasket are replaceable.

Cylinders with  $\varnothing 50$  or larger bore sizes are tightened with a large tightening torque and cannot be disassembled.

#### **Warning**

- **Only people who have sufficient knowledge and experience are allowed to replace seals.**

The person who disassembles and reassembles the cylinder is responsible for the safety of the product.

#### **Caution**

- **When replacing seals, take care not to hurt your hand or finger on the corners of parts.**

### 3-2-1. Disassembly / Reassembly

#### ⚠ Caution

- **Disassemble and assemble the cylinder on a clean cloth in a clean location. Perform on a clean cloth.**

While disassembling, hold the flats of the tube cover gently in a vice and hold the flats of the rod cover with a spanner or monkey wrench to loosen and remove the rod cover. When reassembling, tighten 0 to 2 degrees more than the original position before disassembling.

Cylinders with  $\varnothing 50$  or larger bore sizes are tightened with a large tightening torque and cannot be disassembled.

### 3-2-2. Removal of seals

#### 1) Rod seal

Insert a precision screwdriver from the front of the cover to pull out the seal as shown in Fig. 3.

#### ⚠ Caution

- **Take caution not to damage the seal groove of the cover at this time.**

#### 2) Piston seal

Wipe off grease around piston seal first to make seal removal easier.

As shown in Fig. 4, hold the piston seal with one hand and push it into the groove so that the piston seal can be lifted off and pulled out without using a precision screwdriver.

The groove of the piston is deep, so if the piston seal is removed with a precision screwdriver, it might be damaged.

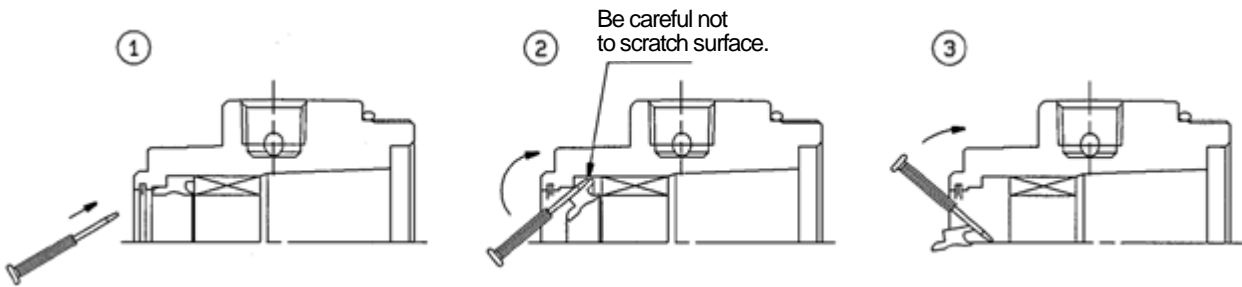

Fig. 3 How to remove rod seal

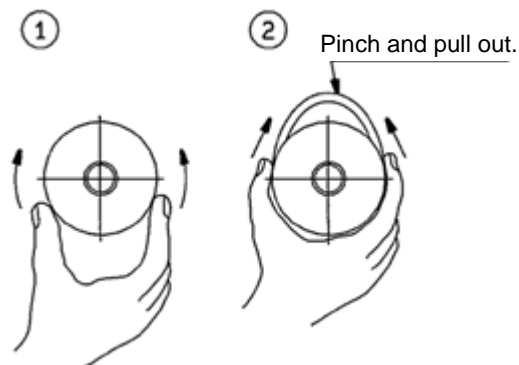

Fig. 4 How to remove piston seal

#### 3) Tube gasket

Pull out with the precision screwdriver.

### 3-2-3. Grease

#### ⚠ Caution

- Use our recommended grease.

Grease pack part number: GR-S-010 (10g), GR-S-020 (20g)

1) ① Rod seal

Apply a thin layer of grease to all surfaces of the new seal to make it easy to install the rod seal and improve sealing.

Fill the groove of the seal with grease, which is necessary for operation.

2) ② Piston seal

Apply a thin layer of grease to all surfaces of the piston seal to make it easy to install the seal.

3) ④ Tube gasket

Apply a thin layer of grease to all surfaces of the tube gasket to make it easy to install the gasket.

4) Parts of cylinder

Grease is applied to the locations shown in Fig.5. The amount of grease per cylinder of 100 stroke is shown in attached table 1. Roughly, one scoop with a forefinger is approximately 3g.

$$L \doteq 100\text{mm, or stroke} \times \frac{1}{2}$$

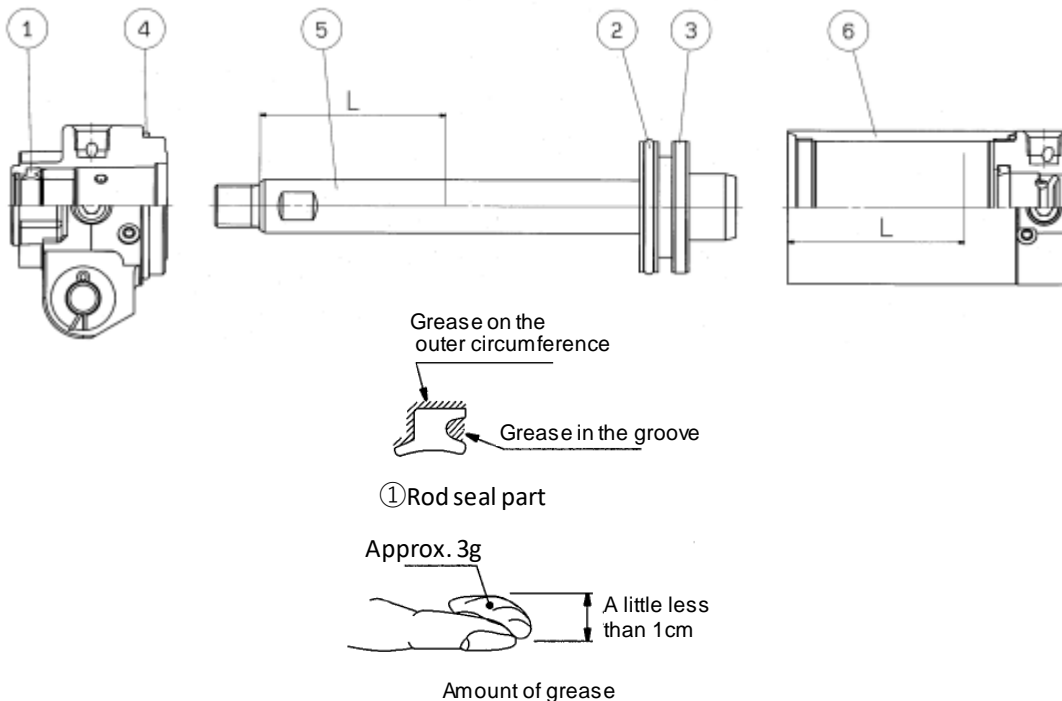

Fig. 5 Position for application of grease

Table 1 Amount of grease

Unit: g

Stroke \ Bore size	Ø40	Position for grease
At 100st	3 to 4	① ② ③ ④ ⑤ ⑥
50st added	1	⑤ ⑥

### 3-2-4. Installation of seals

#### 1) Rod seal (Fig. 5, ① )

Installing directions of the seal are specified.

Apply grease all over the seal and inner surface of the bushing as shown in Fig. 6. If it is difficult to apply grease, for example to a small bore size, use a precision screwdriver.

#### 2) Piston seal (Fig. 5, ② )

Install with care not to twist the piston seal. Apply grease to the seal groove and outer circumference by rubbing grease into them as shown in Fig. 7.

#### 3) Tube gasket (Fig. 5, ④ )

Install with care not to twist the tube gasket.

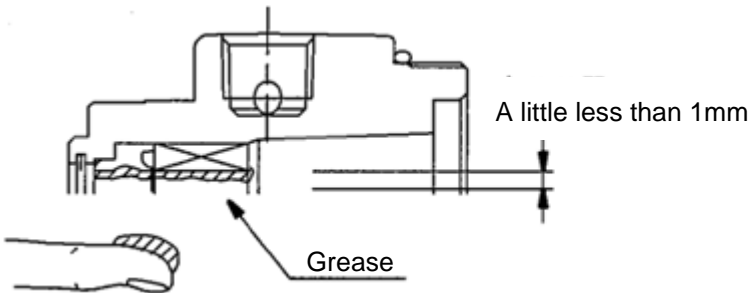

Fig. 6 Rod seal

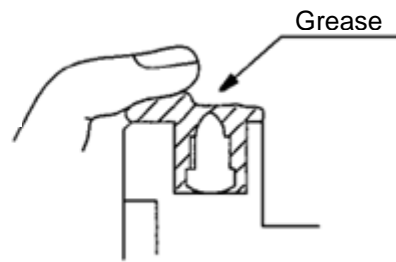

Fig. 7 Piston seal

### ⚠ Caution

- Confirm that there is no problem with operation and sealing ability after assembly.

## 3-3. Consumable parts

### 3-3-1 Replacement parts

	Ø40
Seal kit number	CK1A40-PS
Contents of the seal kit	Rod seal Piston seal Tube gasket 1pc. of each

Grease pack part number: GR-S-010(10g)  
GR-S-020 (20g)

### ⚠ Caution

- The seal is not delivered in sealed packaging for independent storage, so it must be used within 1 year.

### 3-3-2. Storage of seals

#### **Caution**

- Store seals in sealed packaging such as polyethylene bag and place it in a box.
- Avoid locations exposed to direct sunlight, high temperature, and humidity.  
In particular, isolate from equipment that can generate heat, radiation and ozone.
- Do not stack a lot of seals, deform, or damage seals by putting a heavy object on top of them.
- White particles can emerge from the surface of the seal during storage, but they do not affect its performance.

### 3-4. Troubleshooting

Trouble	Major causes	Countermeasures
Operation has lost smoothness.	1. Lubrication failure	- Apply the specified grease after cleaning of parts (Grease pack: GR-S-010(10g) GR-S-020(20g))
	2. Deformation of piston rod	- Replace the cylinder with a new one. When reinstalling the product, adjust the load and mounting position.
	3. Insufficient pressure	- Supply appropriate pressure.
Force has decreased.	1. Air leakage from piston seal	- Replace the piston seal with a new one. See "3-2. Replacement of seals" on page 18.
	2. Air leakage from rod seal	- Replace the rod seal with a new one. See "3-2. Replacement of seals" on page 18.
	3. Insufficient air pressure	- Supply appropriate pressure.
	4. Insufficient flow rate	- The resistance in the fluid path may have increased due to deformation or foreign matter entering the product. Perform repair or cleaning.
	5. Incorrect mounting position of the product	- Mount in a proper position without any force applied to the product.
	6. Deformation of piston rod	- Replace the cylinder with a new one. When reinstalling the product, adjust the load and mounting position.
	7. Lubrication failure	- Refer to the countermeasure for the trouble "Operation has lost smoothness/ lubrication failure."
The product sometimes does not operate.	1. Operation at a very low speed	- Operation at a very low speed can create a condition with almost no pressure difference between the supply side and exhaust side and lower sealing effect, which can cause operation failure. Keep to the specified piston speed.
	2. Problem of equipment other than this product	- Check all items in the system one by one to find the cause. Refer to the catalog and operation manual of the components and equipment for details.
The product has become unable to operate.	1. Damage of piston seal	- If there is leakage from the piston seal, it will be exhausted from the exhaust port of the directional control valve all the time. Replace the piston seal. See "3-2. Replacement of seals" on page 18.
	2. Problem of equipment other than this product	- Check all items in the system one by one to find the cause. Refer to the catalog and operation manual of the components and equipment for details.
	3. Insufficient pressure	- Supply appropriate pressure.
The piston rod has been deformed and broken.	1. Operation at high speed	- Replace the cylinder with a new one. Operation at a high speed can cause impact from the load, deform, and damage the product. Keep within the specified piston speed and allowable kinetic energy.
	2. Excessive external force	- Structural interference, eccentric load or over-load may cause damage and deformation of the cylinder. Eliminate the cause and replace the product with a new one.



Trouble	Major causes	Countermeasures
Switch does not turn on. (Switch sometimes does not turn on)	1. Power supply failure or connection failure	- Check the power supply. - Connect the product properly.
	2. Displacement of auto switch position	- Try to slide the auto switch over the product to check its ON position, and move it to a correct position.
	3. Reduction of magnetic force	- If there is a magnetic source near the product, move it away or install a shield plate to reduce the effect from the magnet. - When the product gets hot, adjust operating frequency to lower it to 60°C. If the above measures do not resolve the problem, replace the product with a new one.
	4. Lowered sensitivity of auto switch	- Eliminate the problem of ambient temperature, vibration, or impact. Replace the switch with a new one if the problem is not solved.
Switch does not turn off. (Switch sometimes does not turn off)	1. Fused contact of auto switch (reed type)	- Check that the voltage and load are within the specified rated values, and replace the auto switch with a new one.
	2. External magnetic field keeping auto switch on.	- If there is a magnetic source near the product, move it away or install a shield plate to reduce the effect from the magnet.

## 4. Basic Circuit for Clamp Cylinder Operation

The basic circuit for operating the product with air filter, regulator, and solenoid valve is shown in the Fig. below.

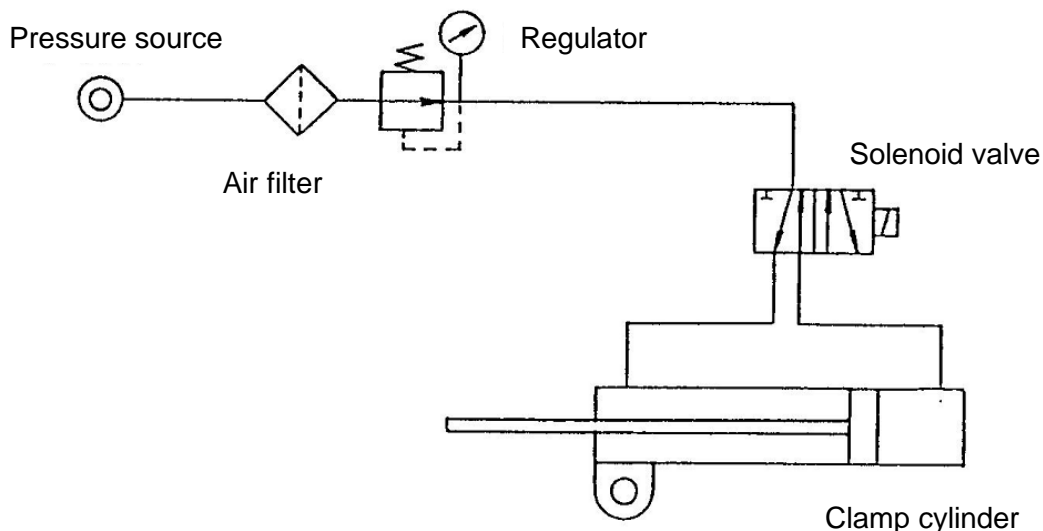

**Fig. 8 Basic circuit**

## 5. Construction

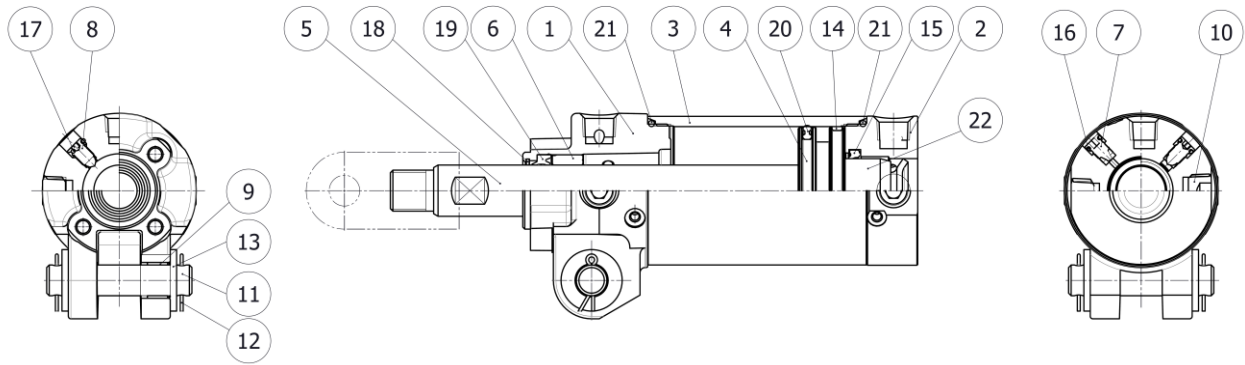

**Fig. 9 Clamp cylinder construction**

No.	Description	Note
1	Rod cover	
2	Head cover	
3	Cylinder tube	
4	Piston	
5	Piston rod	
6	Bushing	
7	Cushion valve	
8	Speed controller valve	
9	Clevis bushing	
10	Hexagon socket head plug	
11	Pin	
12	Cotter pin	
13	Flat washer	
14	Wear ring	
15	Cushion seal	
16	Cushion valve seal	
17	Speed controller valve seal	
18	Coil scraper	
19	Rod seal	
20	Piston seal	
21	Tube gasket	
22	Cushion ring	

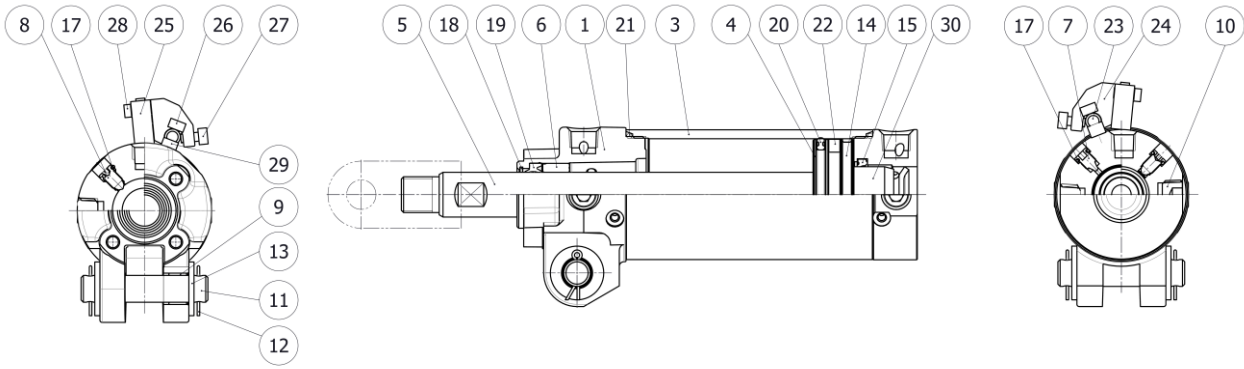

**Fig. 10 Construction of the standard built-in magnet clamp cylinder**

No.	Description	Note
1	Rod cover	
2	Head cover	
3	Cylinder tube	
4	Piston	
5	Piston rod	
6	Bushing	
7	Cushion valve	
8	Speed controller valve	
9	Clevis bushing	
10	Hexagon socket head plug	
11	Pin	
12	Cotter pin	
13	Flat washer	
14	Wear ring	
15	Cushion seal	
16	Cushion valve seal	
17	Speed controller valve seal	
18	Coil scraper	
19	Rod seal	
20	Piston seal	
21	Tube gasket	
22	Magnet	
23	Switch mounting rod	
24	Auto switch mounting bracket	
25	Magnetic field resistant auto switch	
26	Hexagon socket head cap screw	M4x0.7x14L
27	Hexagon socket head cap screw	M4x0.7x8L
28	Hexagon socket head cap screw	M3x0.5x14L
29	Switch mounting spacer	
30	Cushion ring	

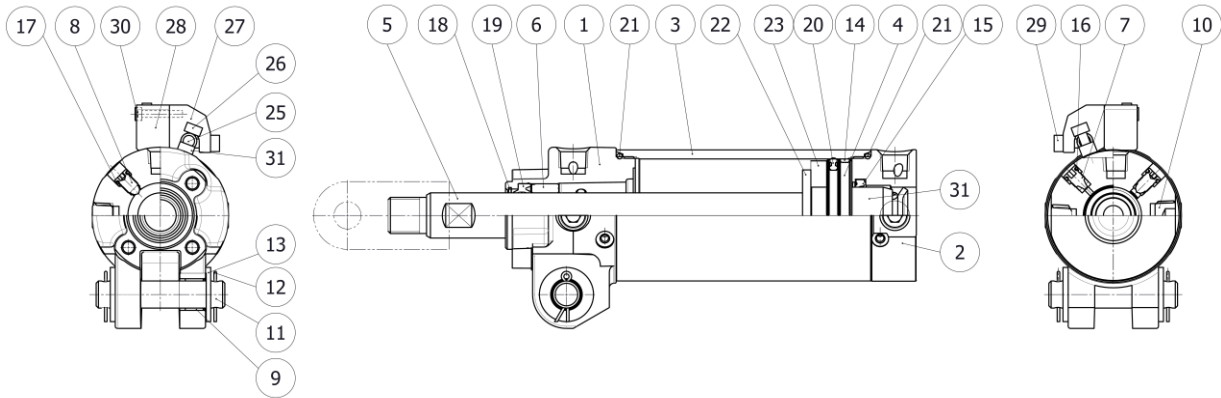

**Fig. 11 Construction of the built-in strong magnet clamp cylinder**

No.	Description	Note
1	Rod cover	
2	Head cover	
3	Cylinder tube	
4	Piston	
5	Piston rod	
6	Bushing	
7	Cushion valve	
8	Speed controller valve	
9	Clevis bushing	
10	Hexagon socket head plug	
11	Pin	
12	Cotter pin	
13	Flat washer	
14	Wear ring	
15	Cushion seal	
16	Cushion valve seal	
17	Speed controller valve seal	
18	Coil scraper	
19	Rod seal	
20	Piston seal	
21	Tube gasket	
22	Magnet holder	
23	Magnet	
24	Switch mounting rod	
25	Auto switch mounting bracket	
26	Magnetic field resistant auto switch	
27	Hexagon socket head cap screw	M4x0.7x14L
28	Hexagon socket head cap screw	M4x0.7x8L
29	Hexagon socket head cap screw	M3x0.5x16L
30	Switch mounting spacer	
31	Cushion ring	

Revision history
1. The contents was changed

# SMC Corporation

Tel: + 81 3 5207 8249 Fax: +81 3 5298 5362  
URL <https://www.smcworld.com>

---

Note: Specifications are subject to change without prior notice and any obligation on the part of the manufacturer.  
© SMC Corporation All Rights Reserved