



Operation Manual

PRODUCT NAME

Precision MONOSASHI-KUN
(High Precision Stroke Reading Cylinder)

MODEL / Series / Product Number

CEP1* Series

SMC Corporation

Contents

1. Safety Instructions	2~6
2. Product Summary	
2-1. System Configuration	7
2-2. How to Order	7
2-2-1. Precision MONOSASHI-KUN	7
2-2-2. Applicable Auto-Switch Models	7
2-2-3. Options	8
2-3. Precautions on Selection	8
3. Specifications	
3-1. Cylinder Specifications	9
3-2. Sensor Specifications	9
4. Wiring	
4-1. Connector Wiring Table	10
4-2. Wiring for CEU5	10
4-3. Noise countermeasures	10
5. Structure and Measuring Principle	
5-1. Structure	11
5-2. Measuring Principle	12
5-3. Relationship Between Pulse and Count	12
6. Troubleshooting	
6-1. Troubleshooting for Measuring Function	13~14
6-2. Troubleshooting for Cylinder Operation	14
Data:	
Outside dimensions of CEP1B12	15
Outside dimensions of CEP1B20	16



Safety Instructions

These safety instructions are intended to prevent hazardous situations and/or equipment damage. These instructions indicate the level of potential hazard with the labels of “**Caution**,” “**Warning**” or “**Danger**.” They are all important notes for safety and must be followed in addition to International Standards (ISO/IEC)^{*)}, and other safety regulations.

*1) ISO 4414: Pneumatic fluid power - General rules and safety requirements for systems and their components
ISO 4413: Hydraulic fluid power - General rules and safety requirements for systems and their components
IEC 60204-1: Safety of machinery - Electrical equipment of machines - Part 1: General requirements
ISO 10218-1: Robots and robotic devices - Safety requirements for industrial robots - Part 1: Robots
etc.



Danger

Danger indicates a hazard with a high level of risk which, if not avoided, will result in death or serious injury.



Warning

Warning indicates a hazard with a medium level of risk which, if not avoided, could result in death or serious injury.



Caution

Caution indicates a hazard with a low level of risk which, if not avoided, could result in minor or moderate injury.



Warning

1. The compatibility of the product is the responsibility of the person who designs the equipment or decides its specifications.

Since the product specified here is used under various operating conditions, its compatibility with specific equipment must be decided by the person who designs the equipment or decides its specifications based on necessary analysis and test results. The expected performance and safety assurance of the equipment will be the responsibility of the person who has determined its compatibility with the product. This person should also continuously review all specifications of the product referring to its latest catalog information, with a view to giving due consideration to any possibility of equipment failure when configuring the equipment.

2. Only personnel with appropriate training should operate machinery and equipment.

The product specified here may become unsafe if handled incorrectly. The assembly, operation and maintenance of machines or equipment including our products must be performed by an operator who is appropriately trained and experienced.

3. Do not service or attempt to remove product and machinery/equipment until safety is confirmed.

1. The inspection and maintenance of machinery/equipment should only be performed after measures to prevent falling or runaway of the driven objects have been confirmed.
2. When the product is to be removed, confirm that the safety measures as mentioned above are implemented and the power from any appropriate source is cut, and read and understand the specific product precautions of all relevant products carefully.
3. Before machinery/equipment is restarted, take measures to prevent unexpected operation and malfunction.

4. SMC products cannot be used beyond their specifications. They are not developed, designed, and manufactured to be used under the following conditions or environments. Use under such conditions or environments is not allowed.

1. Conditions and environments outside of the given specifications, or use outdoors or in a place exposed to direct sunlight.
2. Use for nuclear power, railways, aviation, space equipment, ships, vehicles, military application, equipment affecting human life, body, and property, combustion equipment, entertainment equipment, emergency shut-off circuits, press clutches, brake circuits, safety equipment, etc., and use for applications that do not conform to standard specifications such as catalogs and operation manuals.
3. Use for interlock circuits, except for use with double interlock such as installing a mechanical protection function in case of failure. Please periodically inspect the product to confirm that the product is operating properly.

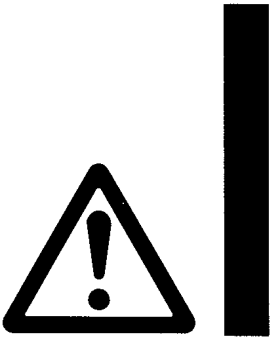

Safety Instructions

Caution

SMC develops, designs, and manufactures products to be used for automatic control equipment, and provides them for peaceful use in manufacturing industries.

Use in non-manufacturing industries is not allowed.

Products SMC manufactures and sells cannot be used for the purpose of transactions or certification specified in the Measurement Act of each country.

The new Measurement Act prohibits use of any unit other than SI units in Japan.

Limited warranty and Disclaimer/Compliance Requirements

The product used is subject to the following “Limited warranty and Disclaimer” and “Compliance Requirements”.

Read and accept them before using the product.

Limited warranty and Disclaimer

1. The warranty period of the product is 1 year in service or 1.5 years after the product is delivered, whichever is first.* 2)

Also, the product may have specified durability, running distance or replacement parts. Please consult your nearest sales branch.

2. For any failure or damage reported within the warranty period which is clearly our responsibility, a replacement product or necessary parts will be provided.

This limited warranty applies only to our product independently, and not to any other damage incurred due to the failure of the product.

3. Prior to using SMC products, please read and understand the warranty terms and disclaimers noted in the specified catalog for the particular products.

***2) Vacuum pads are excluded from this 1 year warranty.**

A vacuum pad is a consumable part, so it is warranted for a year after it is delivered.

Also, even within the warranty period, the wear of a product due to the use of the vacuum pad or failure due to the deterioration of rubber material are not covered by the limited warranty

Compliance Requirements

1. The use of SMC products with production equipment for the manufacture of weapons of mass destruction (WMD) or any other weapon is strictly prohibited.

2. The exports of SMC products or technology from one country to another are governed by the relevant security laws and regulations of the countries involved in the transaction. Prior to the shipment of a SMC product to another country, assure that all local rules governing that export are known and followed.

Operating and Storage Environments

Warning

1. Environments to avoid

Avoid using or storing the products in the following environments which may cause failures. If the products need to be used or stored in those environments, take necessary measures.

- a. Place where ambient temperature exceeds the range of 0°C to 50°C.
- b. Place where ambient humidity exceeds the range of 35% to 85% RH.
- c. Place where condensation occurs due to sudden temperature change.
- d. Place where atmosphere containing corrosive gas, flammable gas or organic solvent.
- e. Place where atmosphere containing conductive powder such as dust and iron chips, oil mist, salt, or organic solvent, or splashing cutting chips, dust and cutting oil (water, liquid) over the products.
- f. Place where the products are exposed to direct sunlight or radiated heat.
- g. Place where strong electromagnetic noise is generated (place where strong electric field, strong magnetic field or surge is generated).
- h. Place where static electricity is discharged or condition that the products have electrostatic discharge.
- i. Place where strong high frequency is generated.
- j. Place where damages of thunder are expected.
- k. Place where vibration or impact is directly given to the products.
- l. Condition that the products are deformed by force or weight applied.

2. Do not close any objects which are affected by magnets.

Since magnets are built in cylinders, do not close magnetic disks, magnetic cards or magnetic tapes. The data may be destroyed.

Precautions on Design

Warning

1. There is a possibility of dangerous sudden action by cylinders if sliding parts of machinery are twisted due to external forces, etc.

In such cases, human injury may occur; e. g., by catching hands or feet in the machinery, or damage to the machinery itself may occur.

2. Provide a cover to minimize the risk of human injury.

When a driven object or moving parts of a cylinder may cause the risk of human injury,

design a structure to avoid contact with human body.

3. Securely tighten all stationary parts and connected parts of cylinders so that they will not become loose.

Tighten cylinders securely especially when they are used in high frequency or in locations where direct vibration or impact shock, etc. will be applied to the body of the cylinder.

4. Deceleration circuits or shock absorbers are needed in some cases.

If a driven object travels at a high speed or is heavy, impact will not be sufficiently absorbed only with the cylinder cushion. In such cases, use a circuit to decelerate the cylinder speed before the cushion becomes effective or use external shock absorbers to reduce impact. At this time, take the rigidity of machinery into account.

5. Consider possible drop of pressure in circuit due to power outage.

For cylinders used in clamping mechanism, a work may become loose due to less clamping force by pressure drop in circuit at the time of power outage. Install safety devices to prevent human injury and machinery damage. Measures should be taken to prevent drop of hanging or lifting equipment.

6. Consider possible loss of power sources.

Measures should be taken to protect against human injury and machinery damage in the event that there is a loss of air pressure, electricity or hydraulic power.

7. Design circuit to prevent shooting out of a driven object.

A driven object is quickly shot out when pressure is supplied from one side of the piston after air in the cylinder is exhausted in such cases that cylinder is actuated by exhaust center type of directional control valve or started after residual air is exhausted from the circuit. At this time, human injury may occur; e.g., by catching hands or feet in the machinery, or damage to the machinery itself may occur. Therefore, the machine should be designed and constructed to prevent shooting out.

8. Consider emergency stops.

Design the machinery so that human injury and/or damage to machinery and equipment will not be caused when machinery is stopped by a safety device under abnormal conditions, a power outage or a manual emergency stop.

9. Consider actions when operation is restarted after an emergency stop or abnormal stop.

Design the machinery so that human injury or equipment damage will not occur upon restart of operation. When the cylinder is required to return to the initial position, provide the equipment with a safe override.

Selection

Warning

manual is designed to be used only in industrial compressed air system. The product should not be used with pressures or temperatures outside the range of the specifications, as this may cause damage or malfunction, etc.

2. Intermediate stop

When cylinder piston is stopped intermediately by 3-position closed center type of directional control valve, intermediate stop positions may not be as precise and exact as hydraulic operation due to compressibility of air. Valves and cylinders are not guaranteed for zero air leakage, and stop position may not be held in a long period of time. Consult SMC for long term holding of stop positions.

Caution

1. Mount speed controller and adjust cylinder operation speed gradually from low speed to a desired speed.

Air Supply

Warning

1. Do not use the product out of the specified ranges for pressure and temperature to pre-vent equipment damage and mal-function.

①Operating pressure:

Ø12: 0.15 to 1.0 MPa

Ø20: 0.1 to 1.0 MPa

②Fluid & ambient temperature: 0 to 60°C

2. Use clean air.

Do not use the product with compressed air includes chemicals, synthetic materials (including organic solvents), salinity, corrosive gases, etc., as this may cause damage or malfunction.

Caution

1. Install air filter.

Install air filter before and in vicinity of valve. The filter should be able to collect particles of 5 microns or smaller. A large quantity of drain may cause malfunction of pneumatic components.

2. Install after cooler, air dryer, auto drain, etc.

Compressed air that includes excessive condensate may cause malfunction of valve and other pneumatic equipment. To prevent this, install after cooler, air dryer, auto drain, etc.

Installation

Warning

1. Do not give torque to the piston rod.
Giving torque to the piston rod may cause damage and malfunction.

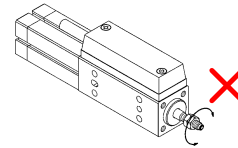

2. Ensure that the equipment operates properly before the use.

3. Operation manual

Do not install the products unless the safety instruction have been read and understood. Keep this operation manual on file for future reference.

4. The threaded section at the end of the piston rod of High Precision Stroke Reading Cylinder is hollow. Please refer to the table below for the allowable tighten torque of the threaded section at the end of the piston rod.

Bore size	Allowable Tighten torque
Φ12	1.5N·m
Φ20	6.0N·m

Caution

1. Maintenance space

When installing the products, allow space for maintenance.

2. Installation of attachment

When hardware and nuts are screwed into the piston rod end, the piston rod should be fully retracted.

Use double nuts to fix a work since Precision MONOSASHI-KUN (Stroke Reading Cylinder) does not have any parallel parts at the rod.

3. Do not give strong impact and/or excessive moment when work is mounted.

External force other than allowable moment may cause rattle at guide part and/or increase in sliding resistance.

4. Use the product in such a condition that load is always applied in the axial direction of the piston rod.

When load is applied in other directions than cylinder axial direction, regulate the load itself by the guide.

Perform a complete centering when cylinder is mounted.

5. Avoid the use where torque is always applied to the piston rod or excessive impact acts on.

6. Do not give any damage and gouge on the sliding part of the piston rod.

Wiring

Warning

1. **Preparation for wiring**

Shut off the power before wiring (including insertion and removal of connectors). Mount a protective cover on the terminal block after wiring.

2. **Check the power**

Make sure the power has sufficient capacity and voltages are within the specified range before wiring.

3. **Grounding**

Ground terminal block F.G. (Frame Ground). Do not ground it with devices generating strong electromagnetic noise.

4. **Check wiring**

Incorrect wiring may cause damage or malfunction of the products. Make sure the wiring is correct before operation.

Caution

1. **Separation of signal wires from power wire**

Avoid common or parallel wiring of signal and power wires to prevent malfunction due to noise.

2. **Wiring arrangement and fixation**

Avoid bending cables sharply at connector part or electrical entry in wiring arrangement. Improper arrangement may cause disconnection which in turn causes malfunction. Fix cables close enough not to give excessive force to the connector.

Piping

Caution

1. **Before piping**

Remove cutting chips, cutting oil, dust, etc. in piping by flushing or cleaning before piping. Care should be taken especially that any cutting chips, cutting oil, dust, etc. do not exist after a filter.

2. **At piping**

- ① Foreign matter should not enter. Entering of foreign matter will cause malfunction.
- ② Cutting chips and sealing materials at piping threads should not enter valves when piping and fittings are screwed in. Leave 1.5 to 2 threads when seal tape is used.

Lubrication

Caution

1. **Lubrication of cylinder**

- ① This cylinder is pre-lubricated and can be used without lubrication.
- ② In case of lubrication, use a equivalent of the

turbine oil type 1 ISO VG32. Once lubrication is performed, it should be continued since the initial lubricant flows out causing malfunction.

Sensor Unit

Caution

1. **Do not remove the sensor unit.**

The position and sensitivity of the sensor is adjusted properly. Removing or replacing the sensor may cause malfunction.

2. **External magnetic field should be 14.5mT or less.**

Strong magnetic field in the vicinity may cause malfunction since CEP1 sensor is magnetic type.

3. **Do not pull sensor cable strongly.**

Such action may cause failure.

4. **Power supply line**

Do not mount any switch or relay to power supply line (12 VDC to 24 VDC).

Measurement

SMC products are not intended for use as instruments for legal metrology.

Measurement instruments that SMC manufactures or sells have not been qualified by type approval tests relevant to the metrology (measurement) laws of each country. Therefore, SMC products cannot be used for business or certification ordained by the metrology (measurement) laws of each country.

Maintenance and Check

Caution

1. **Performing regular check**

Check regularly that the products do not operate with failures unsolved. Check should be done by trained and experienced operators.

2. **Dismantling of product and supply/exhaust of compressed air.**

Before dismantling, ensure that drop preventing and runaway preventing treatments are properly provided, shut the power source of air supplied, and exhausts compressed air in the system. When starting operation again, operate the product with care after ensuring that a treatment for preventing extrusion is properly provided.

3. **Prohibition of disassembly and modification**

To prevent accidents such as failures and electric shocks, do not remove the cover to perform disassembly or modification. If the cover has to be removed, shut off the power before removal.

4. **Disposal**

Request a special agent for handling industrial waste to dispose the products.

2. Product Summary

Precision MONOSASHI-KUN is a cylinder that has a built-in linear encoder.

The scale of the magnetic rod and magnetic sensor detects change in piston position, and pulse signal is outputted with A/B quadrature pulse (90° nominal phase relationship). Position detection in 0.01 mm resolution is possible by inputting this signal to Multi-counter CEU5.

2-1 System Configuration

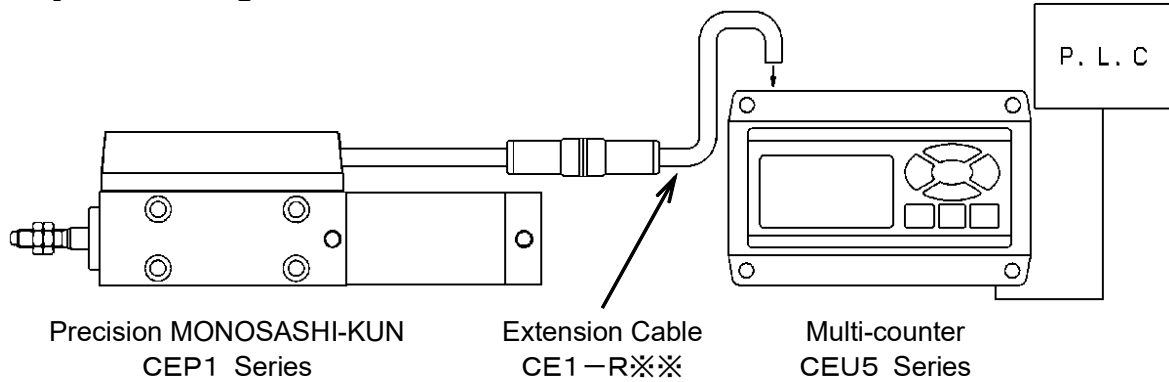

2-2 How to Order

2-2-1 Precision MONOSASHI-KUN

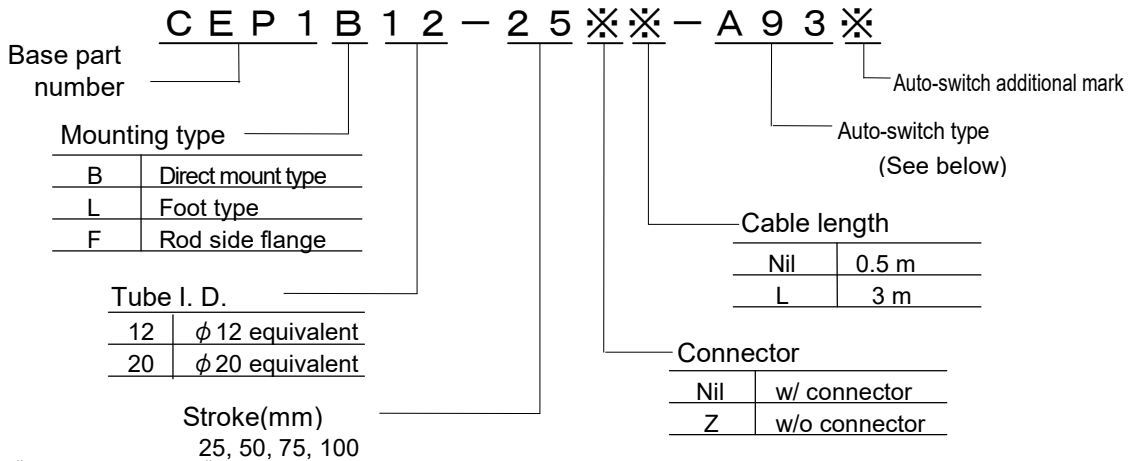

《Made To Order》

Fluoro rubber packing: -XC22 (Ex.) CEP1B12-50-F9N-XC22

2-2-2 Applicable Auto-Switch Models

Mark	Auto-Switch Model	Mark	Auto-Switch Model	Mark	Auto-Switch Model
A90	D-A90	M9N	D-M9N	M9NW	D-M9NW
A93	D-A93	M9P	D-M9P	M9PW	D-M9PW
A96	D-A96	M9B	D-M9B	M9BW	D-M9BW
A90V	D-A90V	M9NV	D-M9NV	M9NWV	D-M9NWV
A93V	D-A93V	M9PV	D-M9PV	M9PWV	D-M9PWV
A96V	D-A96V	M9BV	D-M9BV	M9BWV	D-M9BWV
M9NA	D-M9NA	M9PA	D-M9PA	M9BA	D-M9BA
M9NAV	D-M9NAV	M9PAV	D-M9PAV	M9BAV	D-M9BAV

See separate catalog for the details of Auto-switch.

2-2-3 Options

Multi Counter

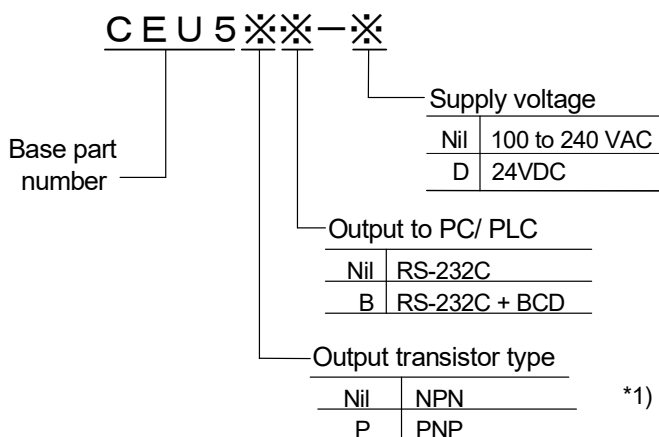

Extension Cable

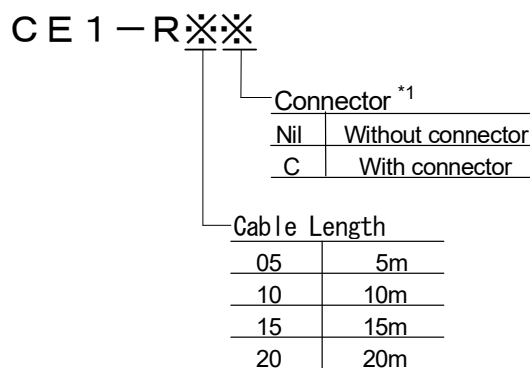

*1) Connector (Female) is mounted on one side of extension cable. Connector (Male) to be enclosed with the mark "C" is the same type as that mounted to standard CEP1.

2-3 Precautions on Selection

- Use Precision MONOSASHI-KUN CEP1 with Multi-Counter CEU5.
Stroke position is not indicated correctly with 3-Point Preset Counter CEU1.
- For SMC CEP1 series and SMC CEU5 series, operation check was performed with SMC extension cable CE1-R※※ for the maximum wire length of 23m. Since operation check was not performed with other counters and cables, a system designer who selects equipment should check the operation.
(See "Countermeasures for Noise" on page 8.)
- When CEP1 with connector is used, extension cable CE1-R※ is necessary. For this extension cable, receptacle connector (female) for CEP1 connector (male) is attached.
- When extension cable is connected to CEP1 without connector, it is necessary to mount male connector on cylinder side. Use CE1-R※C extension cable. For connector with mark "C", one piece of cylinder side connector (male) is enclosed.
- CEP1 without connector can be directly connected to terminal block of counter.

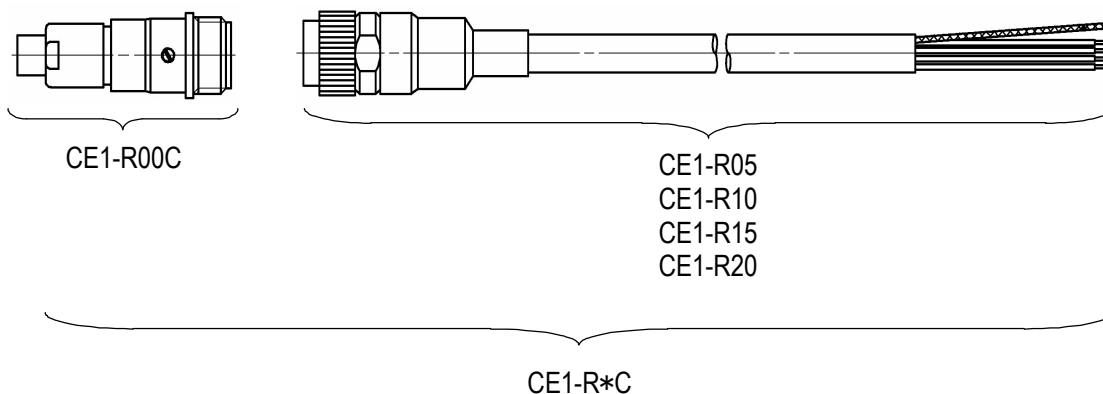

3. Specifications

3-1 Cylinder Specifications

Model	CEP1B12	CEP1B20
Action	Double acting, single rod (Non-rotating piston rod)	
Fluid	Air	
Proof pressure	1.5MPa	
Max. operating pressure	1.0MPa	
Min. operating pressure	0.15 MPa	0.1 MPa
Operating piston speed	50~300mm/s	
Ambient & fluid temperature	0~60° (No freezing)	
Humidity	25~85%RH (No dew condensation)	
Lubrication	Non-lube.	
Stroke tolerance range	0 ~ +1.0	
Cushion	None	
Rod non-rotating accuracy	±2°	±3°
Mounting	Rod side tapping, rod cover through-hole	
Thread tolerance	JSI B0209	

3-2 Sensor Specifications

Cable	φ7, 6-core twisted pair shielding wire (Heat resistance, oil resistance, flameproof)
Maximum wire length	23m* ¹
Position detection method	Incremental encoder (rod with magnetic scale, magnetic sensor)
Magnetic field resistance	14.5mT
Power supply	12 VDC~24VDC (±10%) [Power ripple: 1% or less]
Current consumption	50mA
Resolution	0.01mm (at four times multiplier)
Accuracy(20°C)	±0.02mm* ²
Output type	NPN Open collector (Max. 24 VDC, 40 mA or less)
Output signal	A/B quadrature pulse (90° nominal phase relationship)
Insulation resistance	500 VDC, 50MΩ or more (Case: Between 12E)
Vibration proof	33.3 Hz, 6.8G, two hours each in X and Y directions, four hours in Z direction, Conforming to JIS D1601
Impact resistance	30G, three times each in X, Y and Z directions
Enclosure	IP-67 (IEC standard)* ³

* 1) When SMC cable and SMC CEU5 counter are used.

* 2) Including error due to digital indication at Counter CEU5.

The overall measurement accuracy after being mounted to the equipment may vary depending on the mounting state and environment. When accuracy of the equipment as a whole is required, calibration should be performed by the end users.

* 3) Waterproof for that with cylinder except connector part.

4. Wiring

4-1 Connector Wiring Table

The table below shows combinations of contact mark and wire core color. The connector pin layout shows the layout of CEP1 with connector.

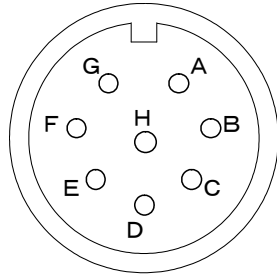

Connector Pin Layout

Combinations of contact mark and core color

Contact Mark	Core Color	Signal
A	White	A-phase
B	Yellow	B-phase
C	Brown	COM(OV)
D	Blue	COM(OV)
E	Red	12 V DC ~24VDC
F	Black	0 V
G	Shield	Shield
H	—	—

4-2 Wiring for CEU5

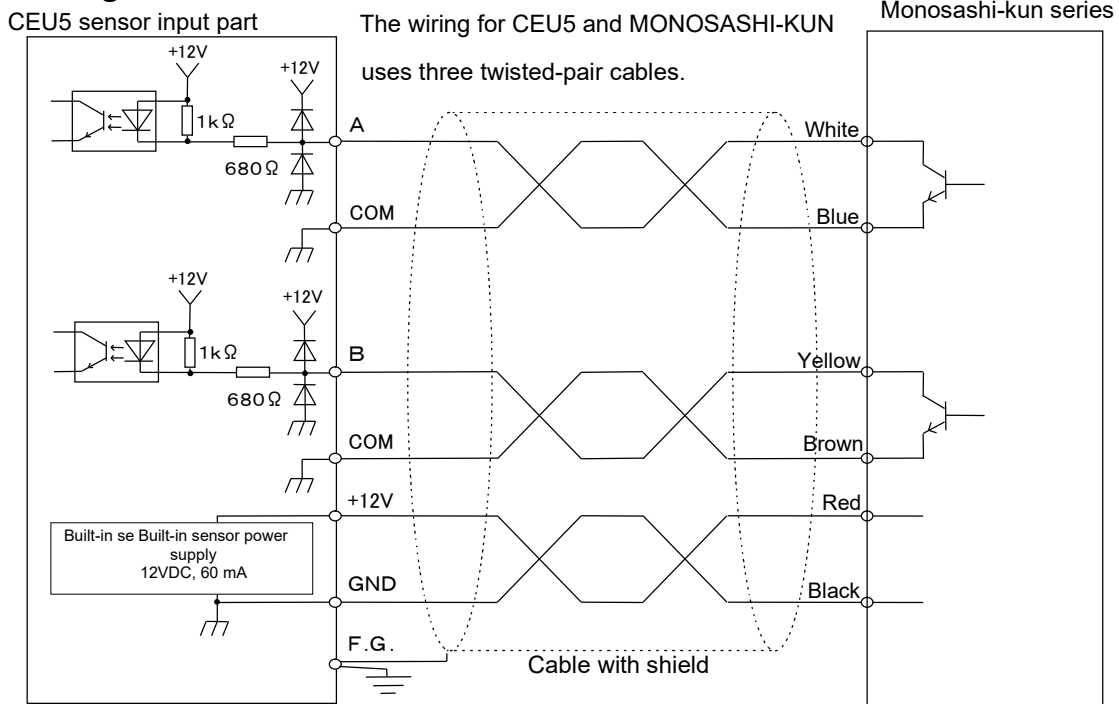

4-3 Noise countermeasures

Follow the instructions below to prevent malfunction due to noise.

1. Use SMC extension cable CE1-R** for wiring of MONOSASHI-KUN and CEU5.
2. Keep signal wires away from the power cables in wiring.
3. Mount a ferrite core to signal cables for possible radiated noise effects of cable.
4. Use stable power source for CEP1 power supply.
5. Mount a noise filter for possible noise effects of power source.

* EMC Directive is satisfied by connecting the multi-counter(CEU5** -D).

Please refer to the operation manual of the multi-counter for details.

5. Structure and Measuring Principle

5-1 Structure

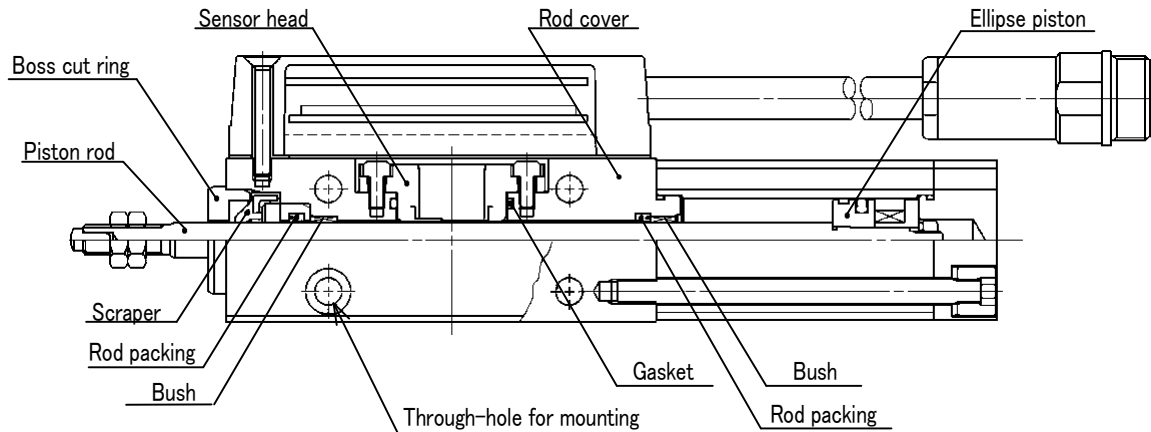

- A part of the piston rod has scale (magnetic scale). In order to maintain the relative position of the scale and the sensor head, ellipse piston is used to have a structure of non-rotating cylinder.



Caution For the use of CEP1, care should be taken for the followings due to the structural characteristics.

- **Do not give torque to the piston rod.**

Giving torque to the piston rod may cause sensor detection failure and cylinder malfunction.

- **Use the product in such a condition that load is always applied in the axial direction of the piston rod.**

Offset load may cause abrasion of bearing and packing. In addition, measuring accuracy may deteriorate.

- **Do not remove the sensor.**

The position and sensitivity of the sensor is adjusted properly. Removing or replacing the sensor may cause malfunction.

- **Do not pull sensor cable strongly.**

Such action may cause detection failure and other failures.

- **External magnetic field should be 14.5mT or less.**

Strong magnetic field in the vicinity may cause malfunction since CEP1 sensor is magnetic type.

This is equivalent to a field in a radius of about 18 cm from a welding part using welding current of about 15000 amperes. When the product is used in stronger magnetic field, take some measures for shield by covering the sensor part with magnetic material.

5-2 Measuring Principle

Precision MONOSASHI-KUN is an air cylinder that has a function to output piston stroke movement as pulse signal in 0.01 mm resolution (at four times multiplier). Measuring Principle is as follows.

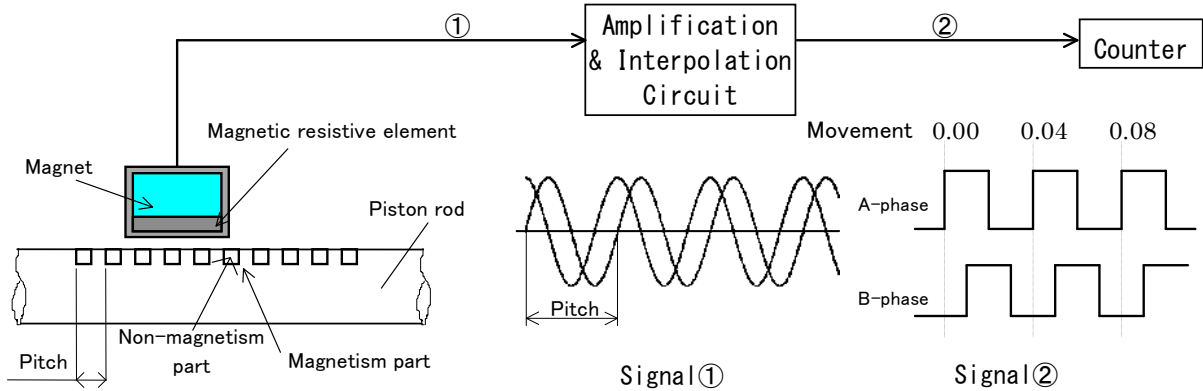

- (1) Piston rod has scale consisting of magnetism layer and non-magnetism layer in 0.8 mm pitch.
- (2) Magnetic resistive element receives 2-phase signal(Signal①) of sin. and cos. by piston rod movement. For this waveform, 1 pitch (0.8 mm) is equal to one cycle.
- (3) This is amplified and divided into 1/20. As a result, 90° phase difference pulse signal (Signal②) is outputted, which is 0.04 mm per pulse.
- (4) By counting this pulse by counter with four-quadrant multiplier, piston position can be detected in 0.01 mm resolution.

5-3 Relationship Between Pulse and Count

CEP1 output is A/B quadrature pulse.

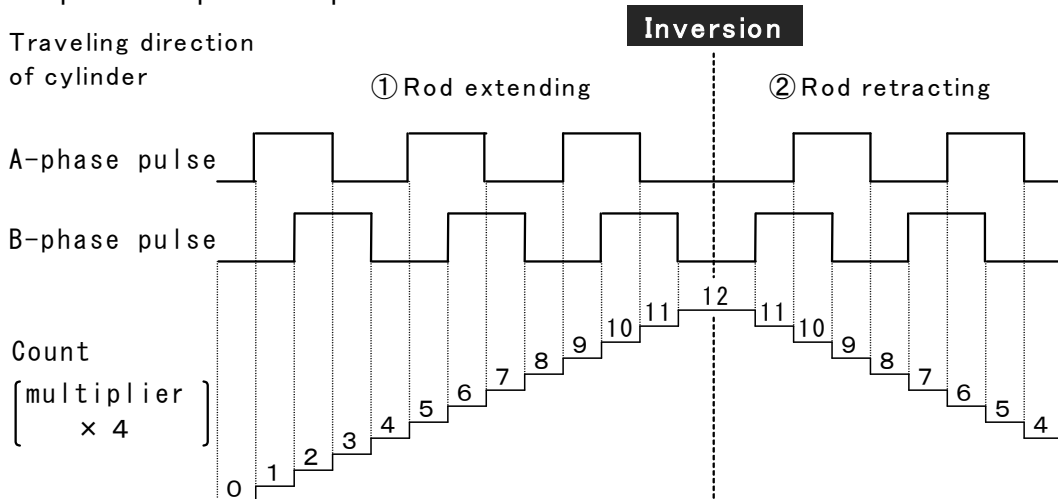

- ① In rod extending direction, A-phase turns on first, then B-phase turns on with the delay of approximately 90° phase difference.
- ② In rod retracting direction, B-phase turns on first, then A-phase turns on with the delay of approximately 90° phase difference. Counter performs addition in ① and does subtraction in ②. When addition in rod retracting direction is needed, switch wiring of A-phase with B-phase.

6. Troubleshooting

6-1 Troubleshooting for Measuring Function

Failure	Cause	Countermeasure	Page of reference
Does not count.	Isn't the wiring removed, or is it correct?	Check the wiring and connector loosening.	10
	Is 12VDC or 24VDC supplied to the sensor?	Supply the rated power (12VDC-24VDC) to the sensor. Power other than the rated may cause failure.	10
	(When CEU5 is used) Is CEU5 in count mode?	Count values are indicated only in the count mode. Press the MODE key to change to the count mode.	See the CEU5 operation manual
	(When other counter is used) Counter setting is wrong.	If input mode switching is available with the counter, check the setting. Set the counter input to adding /subtraction mode, 2-phase input (90° phase difference input).	See the operation manual of the counter.
	Short-circuit of the sensor due to entering of liquid or moisture.	Replacement of sensor unit is necessary if the circuit is corroded. In addition, take some countermeasures to prevent liquid or moisture from entering.	4
	Sensor output circuit will short-circuit if it is improperly wired and current larger than the rated is supplied.	If it failed, repair will be necessary. Consult SMC or the shop.	9, 10
Measured value does not have reproducibility.	Counting speed of the counter is slow or it does not meet the requirements of the input waveform. (Depending on counter, counting speed may slow down due to pulse rise speed and duty conditions.)	CEU5 is recommended. When a counter from other company is used, check the requirements on specifications.	12 and the operation manual of the counter.
	Wiring distance is too long and signal is attenuated. (When counter and cable from other companies are used, wiring distance of 23 m is not guaranteed.)	If the wiring is longer than 23m, provide transducer of differential input/output.	9 and the operation manual of the counter.
	Is there any noise source such as large motor, AC type solenoid valve, relay, inverter power and others in the vicinity?	Take appropriate measures by referring to "Countermeasures for Noise".	10

Failure	Cause	Countermeasure	Page of reference
Measured value does not have reproducibility.	Isn't cylinder speed out of the specified range? When cylinder speed is too fast, counting error may occur. Knocking or bounding may also cause temporal high speed.	Cylinder speed should be in the range of 50 mm/s to 300 mm/s. In addition, prevent knocking and bounding.	9
	Is torque given to the piston rod? If the relative position of the sensor head and the scale is displaced, detection failure may be the result.	Do not give torque to the piston rod.	5, 1 1

6-2 Troubleshooting for Cylinder Operation

Failure	Cause	Countermeasure	Page of reference
Cylinder does not operate.	Is air piping correct?	Check the piping. Perform it after thoroughly reading the precautions in Chapter 1.	5,6
	Isn't the orifice closed completely?	If the orifice is closed completely, open it gradually until it is adjusted properly.	5
	Is torque given to the piston rod? It causes malfunction due to torsion of ellipse piston and the sliding face.	Do not give torque to the piston rod. When operation returns to normal, repair will be required.	5, 1 1
Knocking occurs.	Is cylinder speed within the specified range?	Cylinder speed should be in the range of 50 mm/s to 300 mm/s.	9
	When it is connected to the guide and other equipment, are they centered completely?	Perform centering completely for the connection of other equipment and attachment.	5, 1 1
	Is torque given to the piston rod? It causes malfunction due to torsion of ellipse piston and the sliding face.	Do not give torque to the piston rod.	5, 1 1
	Was lubrication once applied and stopped afterward?	Use the product without lubrication. Once lubrication is performed, it should be continued since the initial grease flows out.	6
	Is the cylinder splashed with solvents and chemicals? Solvents and chemicals may make grease flow out and affect packing.	Do not use in an environment where the product is splashed with solvents and chemicals.	4,5

Revision history
First edition: March 1998
A: Revised in May 1999
B: Revised in July 2011
C: Revised in May 2013
D: Revised in March 2014
E: Revised in March 2023
F: Revised in February 2024
G: Revised in December 2024

SMC Corporation

Tel: + 81 3 5207 8249 Fax: +81 3 5298 5362
URL <https://www.smcworld.com>

Note: Specifications are subject to change without prior notice and any obligation on the part of the manufacturer.
© SMC Corporation All Rights Reserved