



Operation Manual

PRODUCT NAME

Soft Start-up Valve

MODEL / Series / Product Number

AV2000-(F,N)02(B,G,S)-1~6(G,D,Y,DO,YO,KO)(Z)(B,C)(-R,Z)-A
AV3000-(F,N)03(B,G,S)-1~6(G,D,Y,DO,YO,KO)(Z)(B,C)(-R,Z)-A
AV4000-(F,N)04(B,G,S)-1~6(G,D,Y,DO,YO,KO)(Z)(B,C)(-R,Z)-A
AV5000-(F,N)06~10(B,G,S)-1~6(G,D,Y,DO,YO,KO)(Z)(B,C)(-R,Z)-A

AVA2000-(F,N)02(B,G,S)(-R,Z)-A
AVA3000-(F,N)03(B,G,S)(-R,Z)-A
AVA4000-(F,N)04(B,G,S)(-R,Z)-A
AVA5000-(F,N)06~10(B,G,S)(-R,Z)-A

AVL2000-(F,N)02(B,G,S)-(1~6)(D,Y,DO,YO,KO)(Z)(-R,Z)-A
AVL3000-(F,N)02(B,G,S)-(1~6)(D,Y,DO,YO,KO)(Z)(-R,Z)-A
AVL4000-(F,N)02(B,G,S)-(1~6)(D,Y,DO,YO,KO)(Z)(-R,Z)-A
AVL5000-(F,N)06~10(B,G,S)-(1~6)(D,Y,DO,YO,KO)(Z)(-R,Z)-A

SMC Corporation

Contents

	Page
1. Safety Instructions	2~14
2. Application	15
3. Specifications	15~16
4. How to Order	17~21
5. Construction / Parts List	22~23
6. Assembly of Optional Parts	24
7. Working Principle	25
8. Trouble Shooting	26
9. Disassembly Drawing	27
10. Dimensions	28~34



Safety Instructions

These safety instructions are intended to prevent hazardous situations and/or equipment damage. These instructions indicate the level of potential hazard with the labels of “**Caution**,” “**Warning**” or “**Danger**.” They are all important notes for safety and must be followed in addition to International Standards (ISO/IEC)^{*)}, and other safety regulations.

*1) ISO 4414: Pneumatic fluid power - General rules and safety requirements for systems and their components
ISO 4413: Hydraulic fluid power - General rules and safety requirements for systems and their components
IEC 60204-1: Safety of machinery - Electrical equipment of machines - Part 1: General requirements
ISO 10218-1: Robots and robotic devices - Safety requirements for industrial robots - Part 1: Robots
etc.



Danger

Danger indicates a hazard with a high level of risk which, if not avoided, will result in death or serious injury.



Warning

Warning indicates a hazard with a medium level of risk which, if not avoided, could result in death or serious injury.



Caution

Caution indicates a hazard with a low level of risk which, if not avoided, could result in minor or moderate injury.



Warning

1. The compatibility of the product is the responsibility of the person who designs the equipment or decides its specifications.

Since the product specified here is used under various operating conditions, its compatibility with specific equipment must be decided by the person who designs the equipment or decides its specifications based on necessary analysis and test results. The expected performance and safety assurance of the equipment will be the responsibility of the person who has determined its compatibility with the product. This person should also continuously review all specifications of the product referring to its latest catalog information, with a view to giving due consideration to any possibility of equipment failure when configuring the equipment.

2. Only personnel with appropriate training should operate machinery and equipment.

The product specified here may become unsafe if handled incorrectly. The assembly, operation and maintenance of machines or equipment including our products must be performed by an operator who is appropriately trained and experienced.

3. Do not service or attempt to remove product and machinery/equipment until safety is confirmed.

1. The inspection and maintenance of machinery/equipment should only be performed after measures to prevent falling or runaway of the driven objects have been confirmed.
2. When the product is to be removed, confirm that the safety measures as mentioned above are implemented and the power from any appropriate source is cut, and read and understand the specific product precautions of all relevant products carefully.
3. Before machinery/equipment is restarted, take measures to prevent unexpected operation and malfunction.

4. Our products cannot be used beyond their specifications. Our products are not developed, designed, and manufactured to be used under the following conditions or environments. Use under such conditions or environments is not covered.

1. Conditions and environments outside of the given specifications, or use outdoors or in a place exposed to direct sunlight.
2. Use for nuclear power, railways, aviation, space equipment, ships, vehicles, military application, equipment affecting human life, body, and property, fuel equipment, entertainment equipment, emergency shut-off circuits, press clutches, brake circuits, safety equipment, etc., and use for applications that do not conform to standard specifications such as catalogs and operation manuals.
3. Use for interlock circuits, except for use with double interlock such as installing a mechanical protection function in case of failure. Please periodically inspect the product to confirm that the product is operating properly.

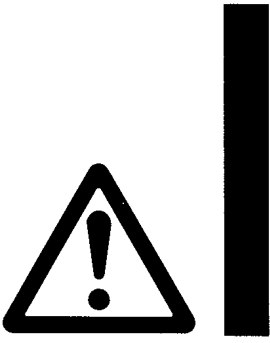

Safety Instructions

Caution

We develop, design, and manufacture our products to be used for automatic control equipment, and provide them for peaceful use in manufacturing industries.

Use in non-manufacturing industries is not covered.

Products we manufacture and sell cannot be used for the purpose of transactions or certification specified in the Measurement Act.

The new Measurement Act prohibits use of any unit other than SI units in Japan.

Limited warranty and Disclaimer/Compliance Requirements

The product used is subject to the following “Limited warranty and Disclaimer” and “Compliance Requirements”.

Read and accept them before using the product.

Limited warranty and Disclaimer

1. The warranty period of the product is 1 year in service or 1.5 years after the product is delivered, whichever is first.*2)

Also, the product may have specified durability, running distance or replacement parts. Please consult your nearest sales branch.

2. For any failure or damage reported within the warranty period which is clearly our responsibility, a replacement product or necessary parts will be provided.

This limited warranty applies only to our product independently, and not to any other damage incurred due to the failure of the product.

3. Prior to using SMC products, please read and understand the warranty terms and disclaimers noted in the specified catalog for the particular products.

***2) Vacuum pads are excluded from this 1 year warranty.**

A vacuum pad is a consumable part, so it is warranted for a year after it is delivered.

Also, even within the warranty period, the wear of a product due to the use of the vacuum pad or failure due to the deterioration of rubber material are not covered by the limited warranty

Compliance Requirements

1. The use of SMC products with production equipment for the manufacture of weapons of mass destruction (WMD) or any other weapon is strictly prohibited.

2. The exports of SMC products or technology from one country to another are governed by the relevant security laws and regulations of the countries involved in the transaction. Prior to the shipment of a SMC product to another country, assure that all local rules governing that export are known and followed.

Design

Warning

1. Actuator operation

When using solenoid valve or actuator in the outlet side of this product, implement appropriate measures to prevent potential danger caused by actuator operation.

2. Holding pressure

Since the valve might have slight internal leakage, it is not suitable for holding pressure in a tank or another vessel for a long period of time.

3. Not suitable for use as an emergency shutoff valve etc.

The valves listed in this catalog are not designed for safety applications such as an emergency shutoff valve. If the valves are used for the mentioned applications, additional safety measures should be adopted.

4. Ventilation

Provide ventilation when using a valve in a confined area, such as in a closed control panel. For example, install a ventilation opening etc. in order to prevent pressure from increasing inside of the confined area and to release the heat generated by the valve.

5. Lock out

We recommend using a lock with a shackle diameter of $\phi 5$ or more for this product (with lock out valve). If a lock with a shackle of less than $\phi 5$ is to be used, please test it on the actual machine.

Selection

Warning

1. Confirm the specifications

The products presented in this catalog are designed only for use in compressed air systems. Do not operate at pressures, temperatures, etc., beyond the range of the specifications, as this can cause damage or malfunction. (Refer to the specifications.)

2. Operation of closed center solenoid valves

Even if this product is used for closed center solenoid valves or actuator with a load factor of 50% or more, lurching (quick extension) cannot be prevented.

3. Using a regulator in the outlet side

When mounting a regulator in the outlet side (A port side), use a check type regulator (AR20K to 60K). With a standard regulator (AR20 to 60), the outlet side pressure may not be released when this valve is exhausted.

4. Operation of solenoid valves in the outlet side

To operate solenoid valves mounted on this product's outlet side (A port side), first confirm that the outlet side's pressure (P_A) has increased to become equal to the inlet side's pressure (P_P).

5. Operation

The residual pressure release function of this product is for emergency use only; therefore, avoid the operation in the same manner as ordinary 3 port valves.

6. Using a lubricator

If mounting a lubricator, mount it on the inlet side (P port side), of this product. If mounted on the outlet side (A port side), back flow of oil will occur and may spurt out of R port.

7. Operation for air blowing

This product cannot be operated for air blowing due to the mechanism that switches the main valve to be fully open after the outlet side's pressure (P_A) increase to approximately 1/2 of the inlet side's pressure (P_P).

8. Extended periods of continuous energization

If a valve will be continuously energized for an extended period of time, the temperature of the valve will increase due to the heat generated by the coil assembly. This will likely adversely affect the performance of the valve. Therefore, if the valve is to be energized for periods of longer than 30 minutes at a time, we advise using the valve with DC specification type which is lower power consumption.

⚠ Caution

1. Leakage voltage

Particularly when using a C-R element (surge voltage suppressor) to protect the switching element, take note that leakage current will flow through the C-R element, thus increasing leakage voltage.

AC coil is 8% or less of the rated voltage.

DC coil is 3% or less of the rated voltage.

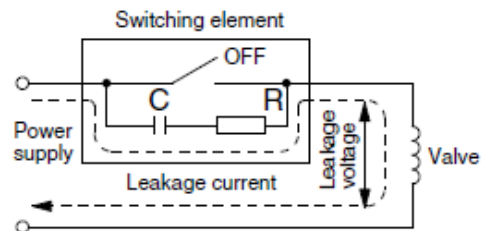

2. Low temperature operation

Although the valve can be operated at temperature as low as 0 °C, measure should be taken 0 °C to avoid solidifying or freezing drainage and moisture, etc.

Mounting

⚠ Warning

1. Operation manual

Mount and operate the product after reading the manual carefully and understanding its contents. Also, keep the manual in a place where it can be referred to as necessary.

2. Maintenance space

Allow sufficient space for maintenance and inspection.

3. If air leakage increases or equipment does not operate properly, stop operation.

After mounting or maintenance, etc., connect the compressed air and power supplies, and perform appropriate function and leakage tests to confirm that the unit is mounted properly.

4. Painting and coating

Warnings or specifications printed or labeled on a product should not be erased, removed or covered up.

Furthermore, painting the resin parts, as this may cause adverse effects depending on the solvent.

Adjustment

Caution

1. Needle operation of low speed air supply

To perform the initial speed adjustment of the outlet side actuator, supply air from this product's inlet side and turn ON the pilot valve. Then, rotate the needle counterclockwise from the fully closed position.

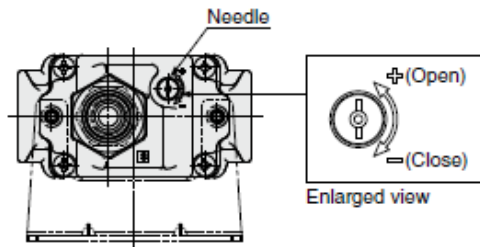

Product bottom surface (exhaust port side)

Piping

Warning

1. Preparation before piping

Before piping is connected, it should be thoroughly blown out by air (flushing) or washed to remove chips, cutting oil and other debris from inside the pipe.

2. Winding of sealant tape

When screwing together pipes and fittings, etc., be certain that chips from the pipe threads and sealing material do not get inside the product. Also, when the sealant tape is used, leave 1 thread ridges exposed at the end of the threads.

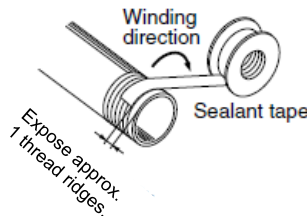

3. Tighten threads with the proper tightening torque

When screwing pipes into this product, tighten with the torques giving below. Also, when using SMC fitting, please tighten with the torque conforming to Catalog or operation manual.

Recommended tightening torque

Thread size	Torque [N·m]
1/8	3 to 5
1/4	8 to 12
3/8	15 to 20
1/2	20 to 25
3/4	28 to 30
1	36 to 38

4. Piping to products

When piping to products, avoid making an error of supply port etc., by referring to the operation manuals.

5. F.R.L module combination

When connecting to a modular F.R.L. combinations (AC20 to AC60), select one of the spacers from accessories. (Refer to page 23 for details.) However, modular combination with AC40-06 is not available.

Furthermore, connect this product to the outlet side of the F.R.L. combination.

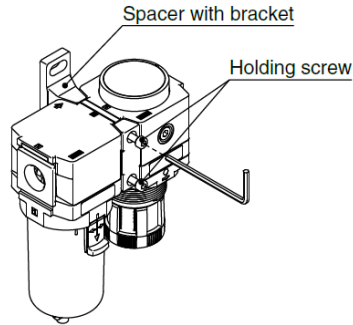

Tighten the 2 holding screws on the spacer with bracket or spacer evenly. Tighten them to the recommended tightening torque. Insufficient tightening torque may result in loosening or sealing failure. Excessive tightening torque may damage the thread, etc.

Recommended Torque

Unit: N·m

Applicable model	AC20□	AC30□	AC40□	AC50□ AC60□
Spacer with Bracket part no.	Y200-T-D	Y300-T-D	Y400-T-D	Y600-T-D
Spacer part no.	Y200-D	Y300-D	Y400-D	Y600-D
Torque	0.36 ±0.036	1.2 ±0.05	1.2 ±0.05	2.0 ±0.1

6. Lockout type handle operating load and moment control

Please do not apply excessive load to the handle when operating the valve switching, when using this product (lockout type) by connected to the outlet side of the F.R.L. combination. Application of excessive moment force to the spacer may cause air leakage. Please consider using one more spacer with bracket on the outlet side of this product, if necessary.

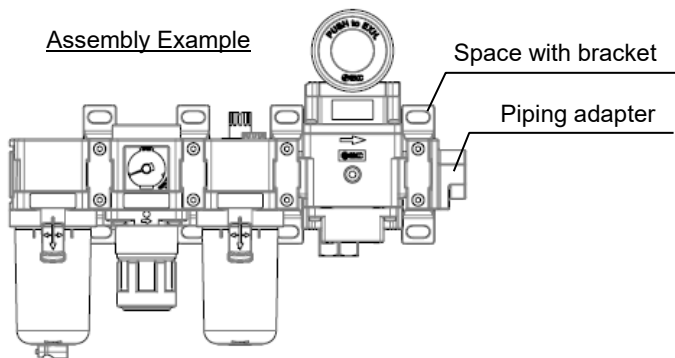

7. Inlet side piping conditions

The normal size of the piping material's or equipment's bore should be equal to or larger than the port size of this product. The combined sonic conductance of the inlet side's (P port side's) piping or equipment should be equal to or larger than the values below. When the piping is restricted or the supply pressure is insufficient, the main valve will not switch and air leakage may occur from the R port.

Series	Combined sonic conductance [dm ³ /(s·bar)]
AV2000-A	1
AV3000-A	4
AV4000-A	7
AV5000-A	10

Wiring



Caution

1. Applied voltage

When electric power is connected to a solenoid valve, be careful to apply the proper voltage. Improper voltage may cause malfunction or coil damage.

2. Check the connection

Check if the connections are correct after completing all wiring.

3. External force applied to the lead wire

If an excessive force is applied to the lead wire, this may cause faulty wiring. Take appropriate measures so that a force of 30N or more is not applied to the lead wire.

4. SMC's Lead Wire Specifications

Cover diameter: 1.55 mm

Conductor area: 0.3 mm² (AWG22 equivalent)

Lubrication



Caution

1. This product has been lubricated for life at the factory, and does not require any further lubrication.
2. If a lubricant is used in the system, use class 1 turbine oil (no additive), ISO VG32. Using other lubricant may cause damage to the product or malfunction. Once lubricant is utilized within the system, since the original lubricant applied within the product during manufacturing will be washed away, please continue to supply lubrication to the system. Without continued lubrication, malfunctions could occur. If turbine oil is used, refer to the corresponding Safety Data Sheet (SDS).
3. **Lubrication amount**
If the lubrication amount is excessive, the oil may accumulate inside the pilot valve, causing a malfunction or response delay. So do not apply a large amount of oil.

Air Supply



Warning

1. Using clear air

Do not use compressed air that contained chemicals, synthetic oils that include organic solvents, salt, corrosive gases, etc., as they may cause damage or malfunction.



Caution

1. Install an air filter

Install an air filter of 5 µm or smaller filtration on upstream side.

2. Take measures to ensure air quality, such as by installing an aftercooler, air dryer, or water separator.

Compressed air that contains a large amount of drainage can cause a malfunction of pneumatic equipment such as valves. Therefore, take appropriate measures to ensure air quality, such as by providing an aftercooler, air dryer, or water separator.

3. Install a mist separator

If an excessive amount of carbon powder is present, install a mist separator on the upstream side. If excessive carbon dust is generated by the compressor, it may adhere to the inside of this product and cause it to malfunction.

Refer to SMC's "Air Cleaning Equipment" catalog for further details on compressed air quality.

Operating Environment



Warning

1. Do not use in atmospheres contacting corrosive gases, chemicals, sea water, water, water steam, or where there is direct contact with any of these.
2. Do not use in explosive atmosphere.
3. Do not use in locations subject to vibration or impact.
4. Do not expose to direct sunlight for an extended period of time. Protective cover should be used to shield.
5. Do not mound in locations where is nearby heat source. Radiated heat should be also prevented.
6. Implement suitable protective measures in locations where there is contact with water droplets, oil, or welding spatter.
7. Install a silencer into exhaust port to prevent the dust ingress if there is a lot of dust in atmosphere, as dust may cause air leakage.

Maintenance



Warning

1. Perform maintenance inspections according to the procedures indicated in the operation manual.

If handled improperly, malfunction and damage of machinery or equipment may occur.

2. Removal of equipment and supply/exhaust of compressed air

When components are removed, first confirm that measures are in place to prevent workpieces from dropping, run-away equipment, etc. Then, cut off the supply pressure and electric power, and exhaust all compressed air from the system using the residual pressure release function.

3. Low frequency operation

Valves should be switched at least once every 30 days to prevent a malfunction. (Use caution regarding the air supply.)

4. Manual override operation

When the manual override is operated, connected equipment will be actuated. Confirm the safety before operating.

⚠ Caution

1. Drain removal

Remove drain from air filters periodically.

Manual Override Operation

⚠ Caution

Control by electricity is not available while manual override is operated.

⚠ Warning

■ **Push-turn locking slotted type [Type B]**

While pressing, turn it the direction of the arrow.

If it is not turned, it can be operated the same way as the non-locking type.

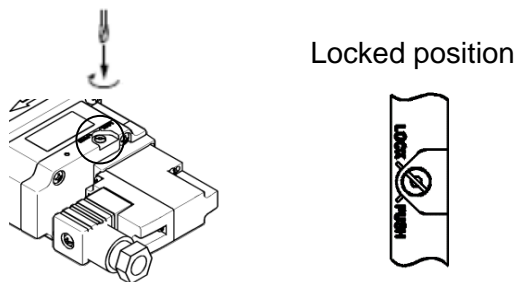

⚠ Caution

When operating the locking type B with a screwdriver, turn it gently using a watchmaker's screwdriver.

[Torque : Less than 0.1N·m]

■ **Push-turn locking lever type [Type C]**

While pressing, turn it the direction of the arrow.

If it is not turned, it can be operated the same way as the non-locking type.

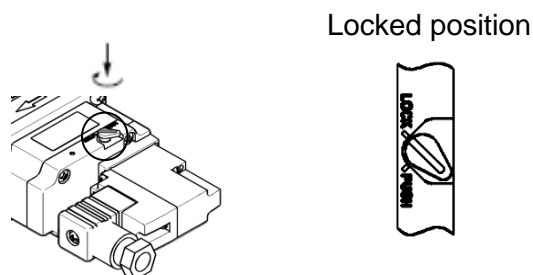

⚠ Caution

When locking the manual override on the push-turn locking types (B, C), be sure to push it down before turning.

Turning without first pushing it down can cause damage to the manual override and trouble such as air leakage etc.

Solenoid Valve for 200/220 VAC Specification

⚠ Warning

AC specification solenoid valves with grommet have a built-in rectifier circuit in the pilot section to operate the DC coil.

With 200/220 VAC specification pilot valves, this built-in rectifier generates heat when energized. The surface may become hot depending on the energized condition; therefore, do not touch the solenoid valves.

Surge Voltage Suppressor

⚠ Caution

<For DC>

Grommet

With light/surge voltage suppressor (GZ)

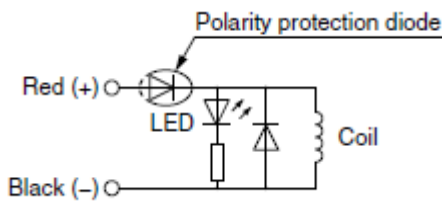

- Connect correctly the lead wires to + (positive) and – (negative) indications on the connector.
- Solenoids, whose lead wires have been pre-wired: positive side red and negative side black.

DIN Terminal

With light/surge voltage suppressor (DZ, YZ)

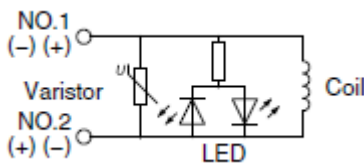

- DIN terminal has no polarity

M12 Connector

With light/surge voltage suppressor (KOZ)

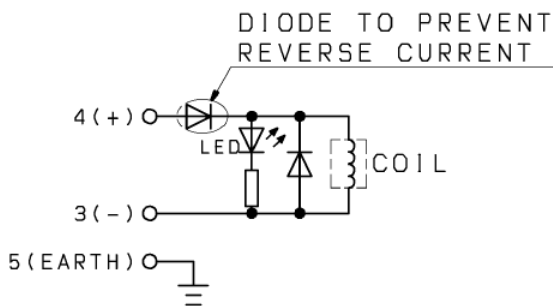

- Connect correctly the lead wires to + (positive) and – (negative) indications on the connector.

Solenoid valve side pin wiring diagram

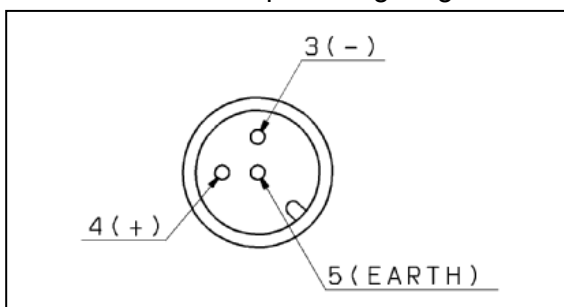

<For AC>

Grommet

With light (GZ)

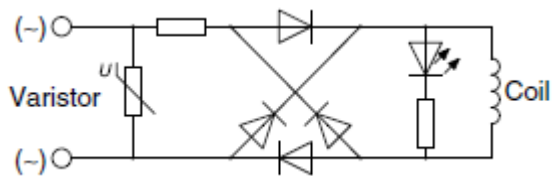

DIN Terminal

With light (DZ, YZ)

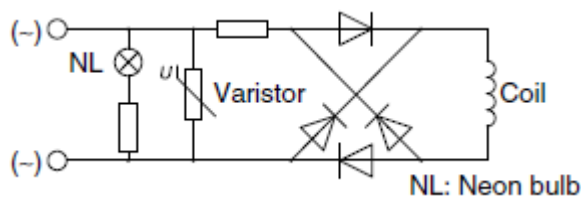

* Surge voltage suppressor of varistor has residual voltage corresponding to the protective element and rated voltage; therefore, protect the controller side from the surge. The residual voltage of the diode is approximately 1 V.

How to Use DIN Terminal Connector

⚠ Caution

Connection

1. Loosen the holding screw and pull the connector out of the solenoid valve terminal block.
2. After removing the holding screw, insert a flat blade screwdriver etc. into the notch on the bottom of the terminal block and pry it open, separating the terminal block and the housing.
3. Loosen the screw (slotted screws) in the terminal block. Insert the lead core wires to the terminals according to the connection method, and secure the wires by re-tightening the terminal screw.
4. Secure the coed by tightening the gland nut

* When making connections, please note that using other than the supported size ($\phi 3.5$ to $\phi 7$) heavy-duty cord will not satisfy IP65 (enclosure) standards. Also, make sure to tighten the gland nut and holding screw within their specified torque ranges.

Changing the entry direction

After separating the terminal block and housing, the core entry can be changed by attaching the housing with 90° interval direction. Note that the direction cannot be changed towards this product.

* When equipped with a light, be careful not to damage the light with the cord's lead wires.

Precautions

Plug in and pull out the connector vertically without tilting to one side.

Compatible cable

Cord O.D.: $\phi 3.5$ to $\phi 7$

(Reference) 0.5mm², 2-core or 3-core, equivalent to JIS C 3306

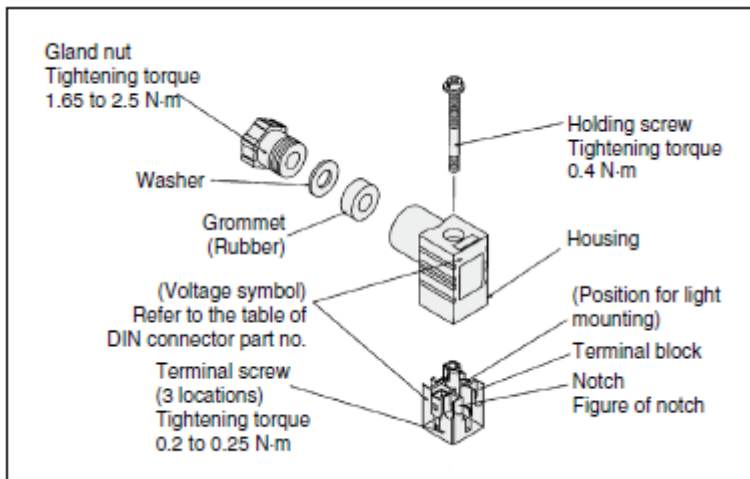

Type "Y"

Y type DIN connector is a DIN connector that conforms to the DIN pitch 8-mm standard.

- D type DIN connector with 9.4mm pitch between terminals is not interchangeable.
- To distinguish from the D type DIN connector, "N" is listed at the end of voltage symbol.
(For connector parts without lights, "N" is not indicated. Refer to the name plate to distinguish.)
- Dimensions are completely the same as D type DIN connector.

DIN Connector Part Nos.

⚠ Caution

<Type D>

Without light	SY100-61-1	SY100-61-1-C
---------------	------------	--------------

With light

Rated voltage	Voltage symbol	Part number (For AV)	Part number (For AVL)
DC24V	24V	SY100-61-3-05	SY100-61-3-05-C
DC12V	12V	SY100-61-3-06	SY100-61-3-06-C
AC100V	100V	SY100-61-2-01	SY100-61-2-01-C
AC200V	200V	SY100-61-2-02	SY100-61-2-02-C
AC110V	110V	SY100-61-2-03	SY100-61-2-03-C
AC220V	220V	SY100-61-2-04	SY100-61-2-04-C

<Type Y>

Without light		SY100-82-1	SY100-82-1-C
---------------	--	------------	--------------

With light

Rated voltage	Voltage symbol	Part number (For AV)	Part number (For AVL)
DC24V	24VN	SY100-82-3-05	SY100-82-3-05-C
DC12V	12VN	SY100-82-3-06	SY100-82-3-06-C
AC100V	100VN	SY100-82-2-01	SY100-82-2-01-C
AC200V	200VN	SY100-82-2-02	SY100-82-2-02-C
AC110V	110VN	SY100-82-2-03	SY100-82-2-03-C
AC220V	220VN	SY100-82-2-04	SY100-82-2-04-C

Circuit Diagram with Light

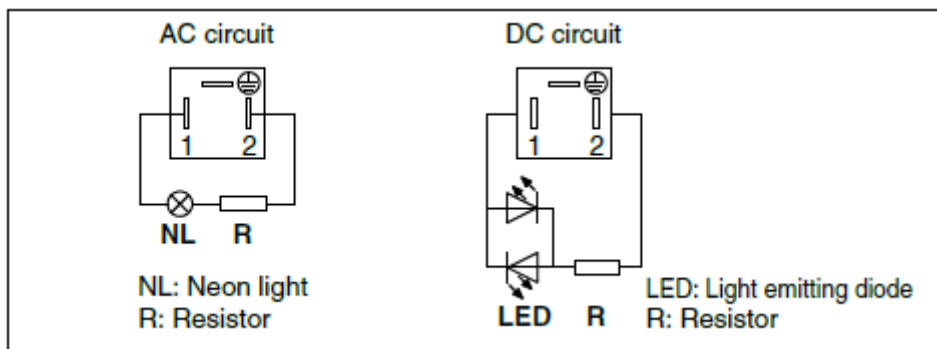

2. Applications

This product is intended for use in circuits that require low speed air supply to gradually raise initial pressure in an air system and for quick exhaust by cutting off air supply when the control power is cut off in the event of a power failure or emergency.

3. Specifications

Specifications

Series		AV2000-A	AV3000-A	AV4000-A	AV5000-A	
Port size	1(P)•2(A)	1/4	3/8	1/2	3/4	1
	3(R)	1/4	3/8	1/2	3/4	
Pressure gauge port size		1/8				
Fluid		Air				
Ambient and fluid temperature		0 to 50 °C *1 (without solenoid valve: 0 to 60 °C *1)				
Proof pressure		1.5MPa				
Operating pressure range		0.2 to 1.0MPa				
Weight (kg)	AV	0.43	0.45	0.80	1.30	1.25
	AVA	0.43	0.45	0.80	1.32	1.27
	AVL (Manual operation)	0.62	0.64	0.99	1.51	1.46
	AVL (Manual operation with solenoid valve)	0.67	0.68	1.03	1.55	1.50
Enclosure		Dust-protected (DIN terminal and M12 connector: IP65 ^{*2})				

*1 If the temperature is low, use the product with dry air to prevent it from freezing.

*2 Based on IEC60529

Solenoid Specifications

Electrical entry		Grommet	DIN terminal	M12 Connector
Rated coil voltage [V]	DC	24, 12V		
	AC 50/60Hz	100, 200, 110[115], 220[230] *1		
Allowable voltage fluctuation	DC	24V	±10% of the rated voltage	
		12V	±10% of the rated voltage	
	AC	100V	±10% of the rated voltage	
		110V *1 [115V]	±10% of the rated voltage [-15% to +5% of the rated voltage]	
		200V	±10% of the rated voltage	
220V *1 [230V]	±10% of the rated voltage [-15% to +5% of the rated voltage]			
Power consumption [W]	DC	0.35 (With light: 0.4)	0.35 (With light: 0.45)	With light: 0.4
Apparent power [VA]	AC	100V	0.78 (With light: 0.81)	0.78 (With light: 0.87)
		110V *1 [115V]	0.86 (With light: 0.89) [0.94 (With light: 0.97)]	0.86 (With light: 0.97) [0.94 (With light: 1.07)]
		200V	1.18 (With light: 1.22)	1.15 (With light: 1.30)
		220V *1 [230V]	1.30 (With light: 1.34) [1.42 (With light: 1.46)]	1.27 (With light: 1.46) [1.39 (With light: 1.60)]
Surge voltage suppressor		Refer to the Specific Product Precautions on page 11 and 12		
Indicator light		LED	LED (Neon bulb for AC)	LED

*1 The 110 VAC and 115 VAC are interchangeable. The 220 VAC and 230 VAC are interchangeable as well.

Flow Rate Characteristics

Series			AV2000-A	AV3000-A	AV4000-A	AV5000-A	
Port size	1(P)→2(A)		1/4	3/8	1/2	3/4	1
	3(R)		1/4	3/8	1/2	3/4	
Flow rate characteristics	1(P)→2(A)	C [dm ³ /(s·bar)]	9.2	13.1	19.2	34.8	41.3
		b	0.36	0.27	0.32	0.66	0.34
		Cv	2.4	3.1	5.1	12.6	13.7
	2(A)→3(R)	C [dm ³ /(s·bar)]	8.8	9.2	10.1	23.7	
		b	0.46	0.48	0.55	0.67	
		Cv	2.5	2.6	3.2	9.2	

Pressure for switching from low speed air supply to rapid air supply

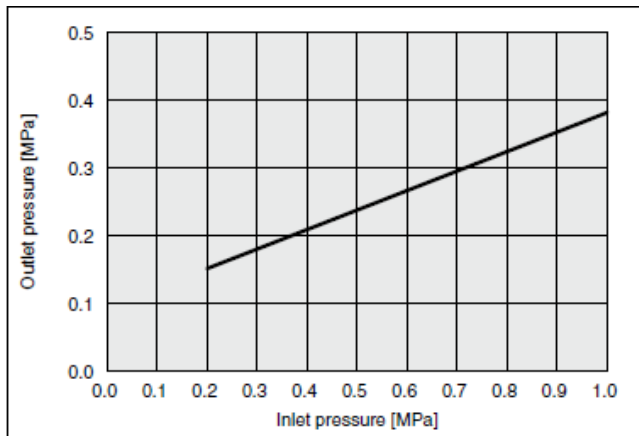

Needle flow characteristics at low speed air supply
* Representative values

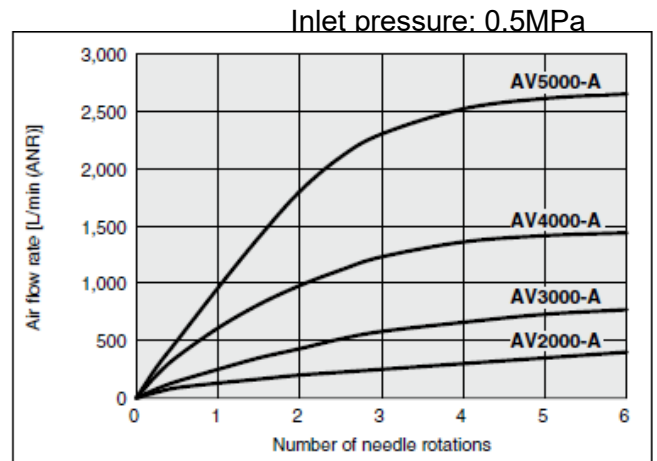

Pilot Pressure range
(for Air operated type)

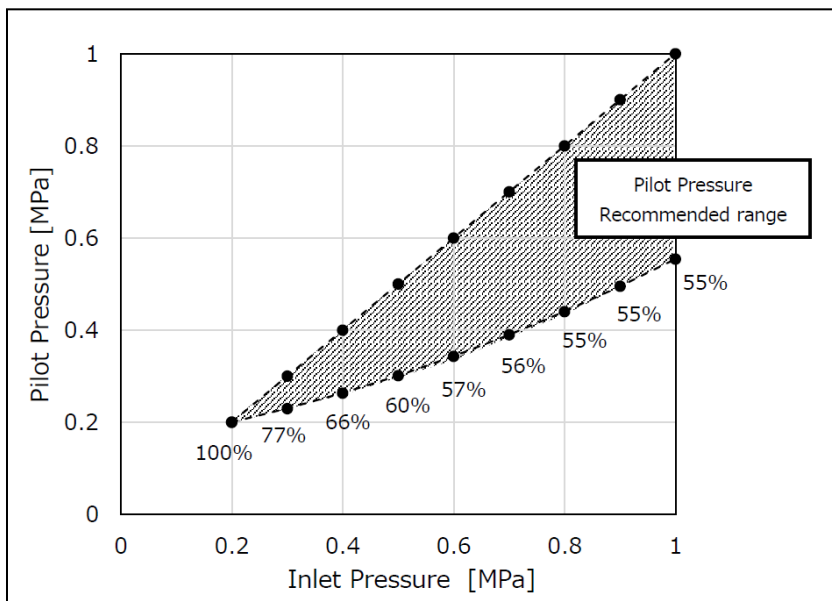

4. How to Order

AV 20 00 - 02 B - 1 D B - - A

1
 2 3 4
 5 6 7 8
 9

		Symbol	Description	1							
				Body size							
				20	30	40	50				
2	Thread type	NIL	Rc	●	●	●	●				
		N	NPT	●	●	●	●				
		F	G	●	●	●	●				
+											
3	Port size 1(P), 2(A)	02	1/4	●	—	—	—				
		03	3/8	—	●	—	—				
		04	1/2	—	—	●	—				
		06	3/4	—	—	—	●				
		10	1	—	—	—	●				
+											
4	Option	a	Mounting	NIL	Without mounting option			●	●	●	●
			B	With bracket			●	●	●	●	
	+										
	b	Pressure gauge	NIL	Without pressure gauge			●	●	●	●	
			G	Round type pressure gauge (with limit indicator)			●	●	●	●	
	+										
c	Silencer	NIL	Without silencer			●	●	●	●		
		S	Silencer (Built-in)			●	●	●	●		
+											
5	d	Rated coil voltage	AC (50/60Hz)	1	100 VAC			●	●	●	●
				2	200 VAC			●	●	●	●
				3	110 VAC [115 VAC] *1			●	●	●	●
			DC	4	220 VAC [230 VAC] *1			●	●	●	●
				5	24 VDC			●	●	●	●
				6	12 VDC			●	●	●	●
+											
6	e	Electrical entry	G	Grommet (Lead wire length: 300mm)			●	●	●	●	
			D	Type D (DIN terminal/With connector)			●	●	●	●	
			Y	Type Y (DIN terminal/With connector) *2			●	●	●	●	
			DO	Type D (DIN terminal/Without connector)			●	●	●	●	
			YO	Type Y (DIN terminal/Without connector)			●	●	●	●	
			KO	M12 connector (Without cable)			○ ^{*3}	○ ^{*3}	○ ^{*3}	○ ^{*3}	
+											
7	f	Light/ surge voltage suppressor	NIL	None			●	●	●	●	
			Z	With light/surge voltage suppressor			○ ^{*4}	○ ^{*4}	○ ^{*4}	○ ^{*4}	
+											
8	g	Manual override	NIL	Non-locking push type			●	●	●	●	
			B	Push-turn locking slotted type			●	●	●	●	
			C	Push-turn locking lever type			●	●	●	●	
+											
9	Semi-standard	h	Flow direction	NIL	Flow direction: Left to right			●	●	●	●
				R	Flow direction: Right to left			●	●	●	●
		+									
i	Pressure unit	NIL	Unit on product label: MPa, Pressure gauge: MPa			●	●	●	●		
		Z ^{*5}	Unit on product label: psi, Pressure gauge: MPa/psi dual scale			○ ^{*6}	○ ^{*6}	○ ^{*6}	○ ^{*6}		

*1 The 110 VAC and 115 VAC are interchangeable. The 220 VAC and 230 VAC are interchangeable as well.

The allowable voltage fluctuation is -15% to +5% of the rated voltage for the 115 VAC or 230 VAC.

*2 Type "Y" is a DIN terminal conforming to EN-175301-803C (former DIN43650C).

CE/UKCA compliant : ● UL certification : ○

	Electrical entry		
	Grommet	DIN terminal	M12 connector
AC	—	●	—
DC	●○	●○	●

*3 When the electrical entry is "KO", only the DC specifications (5 or 6) can be selected for the rated coil voltage.

*4 When the electrical entry is "DO" or "YO", the light/surge voltage suppressor cannot be selected.

When it is "KO", only the "With light/surge voltage suppressor" option can be selected.

*5 For the pipe thread type : NPT

This product is for overseas use only according to the New Measurement Act. (The SI unit type is provided for use in Japan.)

*6 Pressure unit Z : For the pipe thread type : NPT only

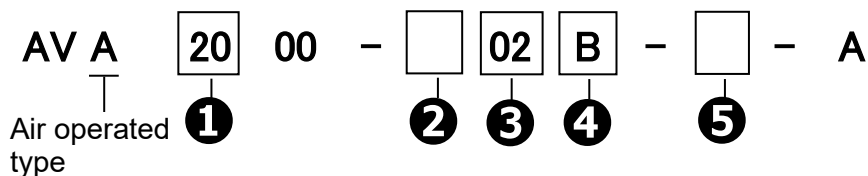

		Symbol	Description	1						
				Body size						
				20	30	40	50			
2	Thread type	NIL	Rc	●	●	●	●			
		N	NPT	●	●	●	●			
		F	G	●	●	●	●			
		+								
3	Port size 1(P), 2(A)	02	1/4	●	—	—	—			
		03	3/8	—	●	—	—			
		04	1/2	—	—	●	—			
		06	3/4	—	—	—	●			
		10	1	—	—	—	●			
		+								
4	Option	a	Mounting	NIL	Without mounting option		●	●	●	●
				B	With bracket		●	●	●	●
			+							
	b	Pressure gauge	NIL	Without pressure gauge		●	●	●	●	
			G	Round type pressure gauge (with limit indicator)		●	●	●	●	
			+							
c	Silencer	NIL	Without silencer		●	●	●	●		
		S	Silencer (Built-in)		●	●	●	●		
		+								
5	Semi-standard	d	Flow direction	NIL	Flow direction: Left to right		●	●	●	●
				R	Flow direction: Right to left		●	●	●	●
				+						
e	Pressure unit	NIL	Unit on product label: MPa, Pressure gauge: MPa		●	●	●	●		
		Z ^{*1}	Unit on product label: psi, Pressure gauge: MPa/psi dual scale		○ ^{*2}	○ ^{*2}	○ ^{*2}	○ ^{*2}		

*1 For the pipe thread type : NPT

This product is for overseas use only according to the New Measurement Act. (The SI unit type is provided for use in Japan.)

*2 Pressure unit Z : For the pipe thread type : NPT only

Manual operation AV L 20 00 - 02 B - A

with solenoid valve AV L 20 00 - 02 B - 1 D - - A

1
2
3
4
5
6
7
8

Lockout type

		Symbol	Description	①					
				Body size					
				20	30	40	50		
②	Thread type	NIL	Rc	●	●	●	●		
		N	NPT	●	●	●	●		
		F	G	●	●	●	●		
+									
③	Port size 1(P), 2(A)	02	1/4	●	—	—	—		
		03	3/8	—	●	—	—		
		04	1/2	—	—	●	—		
		06	3/4	—	—	—	●		
		10	1	—	—	—	●		
+									
④	Option	a	Mounting	NIL	Without mounting option	●	●	●	●
				B	With bracket	●	●	●	●
		+							
		b	Pressure gauge	NIL	Without pressure gauge	●	●	●	●
				G	Round type pressure gauge (with limit indicator)	●	●	●	●
		+							
c	Silencer	NIL	Without silencer	●	●	●	●		
		S	Silencer (Built-in)	●	●	●	●		
+									
⑤	d	Rated coil voltage	AC (50/60Hz)	1	100 VAC	●	●	●	●
				2	200 VAC	●	●	●	●
				3	110 VAC [115 VAC] *1	●	●	●	●
			DC	4	220 VAC [230 VAC] *1	●	●	●	●
				5	24 VDC	●	●	●	●
				6	12 VDC	●	●	●	●
+									
⑥	e	Electrical entry	D	Type D (DIN terminal/With connector)	●	●	●	●	
			Y	Type Y (DIN terminal/With connector) *2	●	●	●	●	
			DO	Type D (DIN terminal/Without connector)	●	●	●	●	
			YO	Type Y (DIN terminal/Without connector)	●	●	●	●	
			KO	M12 connector(Without cable)	○*3	○*3	○*3	○*3	
+									
⑦	f	Light/ surge voltage suppressor	NIL	None	●	●	●	●	
			Z	With light/surge voltage suppressor	○*4	○*4	○*4	○*4	
+									
⑧	Semi-standard	g	Flow direction	NIL	Flow direction: Left to right	●	●	●	●
				R	Flow direction: Right to left	●	●	●	●
		+							
		h	Pressure unit	NIL	Unit on product label: MPa, Pressure gauge: MPa	●	●	●	●
Z*5	Unit on product label: psi, Pressure gauge: MPa/psi dual scale			○*6	○*6	○*6	○*6		

*1 The 110 VAC and 115 VAC are interchangeable. The 220 VAC and 230 VAC are interchangeable as well.

The allowable voltage fluctuation is -15% to +5% of the rated voltage for the 115 VAC or 230 VAC.

*2 Type "Y" is a DIN terminal conforming to EN-175301-803C (former DIN43650C).

*3 When the electrical entry is "KO", only the DC specifications (5 or 6) can be selected for the rated coil voltage.

*4 When the electrical entry is "DO" or "YO", light/surge voltage suppressor cannot be selected.

When it is "KO", only the "With light/surge voltage suppressor" option can be selected.

*5 For the pipe thread type : NPT

This product is for overseas use only according to the New Measurement Act. (The SI unit type is provided for use in Japan.)

*6 Pressure unit Z : For the pipe thread type : NPT only

How to Order of Pilot Valve Assembly

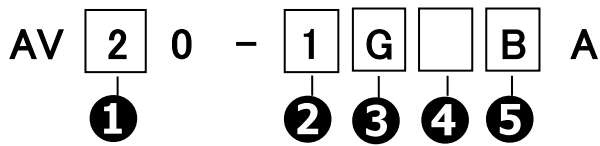

	Symbol	Description
--	--------	-------------

Applicable size			
AV 2000	AV 3000	AV 4000	AV 5000

1	Body size	2	AV2000-A, AV3000-A
		4	AV4000-A, AV5000-A

●	●	—	—
—	—	●	●

2	a	Rated coil voltage	AC (50/60Hz)	1	100 VAC			
				2	200 VAC			
				3	110 VAC [115 VAC] ^{*1}			
				4	220 VAC [230 VAC] ^{*1}			
						DC	5	24 VDC
							6	12 VDC

●	●	●	●
●	●	●	●
●	●	●	●
●	●	●	●
●	●	●	●
●	●	●	●
●	●	●	●

3	b	Electrical entry	G	Grommet (Lead wire length: 300mm)
			D	Type D (DIN terminal/With connector)
			Y	Type Y (DIN terminal/With connector) ^{*2}
			DO	Type D (DIN terminal/Without connector)
			YO	Type Y (DIN terminal/Without connector)
			KO	M12 connector (Without cable)

●	●	●	●
●	●	●	●
●	●	●	●
●	●	●	●
●	●	●	●
●	●	●	●
○ ^{*3}	○ ^{*3}	○ ^{*3}	○ ^{*3}

4	c	Light/surge voltage suppressor	NIL	None
			Z	With light/surge voltage suppressor

●	●	●	●
○ ^{*4}	○ ^{*4}	○ ^{*4}	○ ^{*4}

5	d	Manual override	NIL	Non-locking push type
			B	Push-turn locking slotted type
			C	Push-turn locking lever type

●	●	●	●
●	●	●	●
●	●	●	●

*1 The 110 VAC and 115 VAC are interchangeable. The 220 VAC and 230 VAC are interchangeable as well.

The allowable voltage fluctuation is -15% to +5% of the rated voltage for the 115 VAC or 230 VAC.

*2 Type "Y" is a DIN terminal conforming to EN-175301-803C (former DIN43650C).

*3 When the electrical entry is "KO", only the DC specifications (5 or 6) can be selected for the rated coil voltage.

*4 When the electrical entry is "DO" or "YO", the light/surge voltage suppressor cannot be selected.

When it is "KO", only the "With light/surge voltage suppressor" option can be selected.

Manual operation AV L **2** 0 - A

with solenoid valve AV L **2** 0 - **1** **G** A

1
2
3
4

	Symbol	Description
--	--------	-------------

1	Body size	2	AVL2000 to 5000-A
----------	-----------	----------	-------------------

2	a	Rated coil voltage	AC (50/60Hz)	1	100 VAC			
				2	200 VAC			
				3	110 VAC [115 VAC] ^{*1}			
				4	220 VAC [230 VAC] ^{*1}			
			DC				5	24V DC
							6	12V DC

3	b	Electrical entry		D	Type D (DIN terminal/With connector)
				Y	Type Y (DIN terminal/With connector) ^{*2}
				DO	Type D (DIN terminal/Without connector)
				YO	Type Y (DIN terminal/Without connector)
				KO	M12 connector(Without cable)

4	c	Light/ surge voltage suppressor	NIL	None
			Z	With light/surge voltage suppressor

Applicable size			
AVL 2000	AVL 3000	AVL 4000	AVL 5000

●	●	●	●
---	---	---	---

●	●	●	●
●	●	●	●
●	●	●	●
●	●	●	●
●	●	●	●
●	●	●	●

●	●	●	●
●	●	●	●
●	●	●	●
●	●	●	●
○ ^{*3}	○ ^{*3}	○ ^{*3}	○ ^{*3}

●	●	●	●
○ ^{*4}	○ ^{*4}	○ ^{*4}	○ ^{*4}

^{*1} The 110 VAC and 115 VAC are interchangeable. The 220 VAC and 230 VAC are interchangeable as well.
The allowable voltage fluctuation is -15% to +5% of the rated voltage for the 115 VAC or 230 VAC.

^{*2} Type "Y" is a DIN terminal conforming to EN-175301-803C (former DIN43650C).

^{*3} When the electrical entry is "KO", only the DC specifications (5 or 6) can be selected for the rated coil voltage.

^{*4} When the electrical entry is "DO" or "YO", light/surge voltage suppressor cannot be selected.
When it is "KO", only the "With light/surge voltage suppressor" option can be selected.

5. Construction / Parts list

Appearance

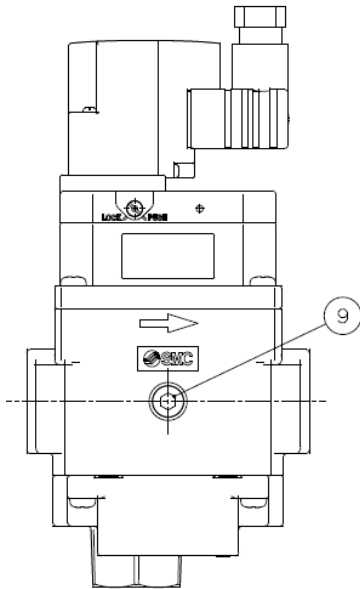

Constructions

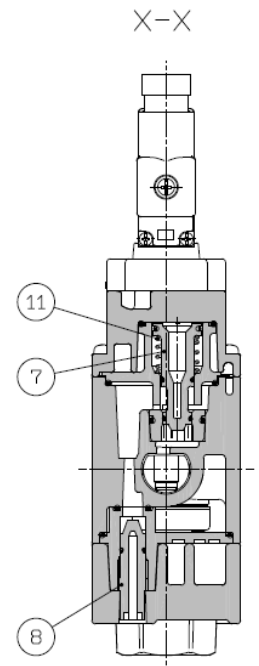
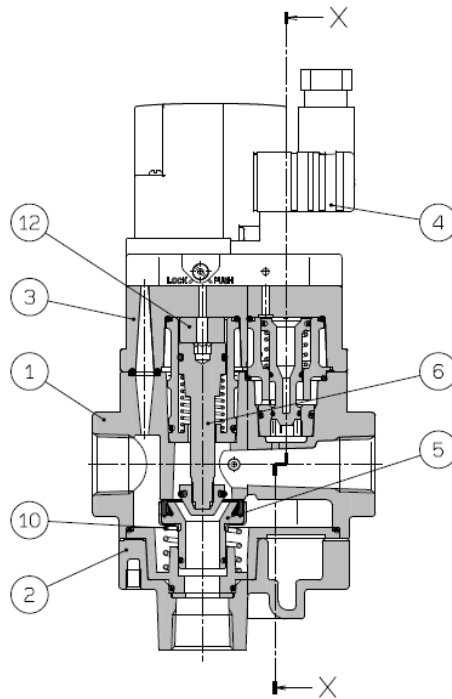

Component Parts

No.	Description	Material
1	Body	Aluminum die-cast
2	Bottom cover	Aluminum die-cast
3	Top cover	Aluminum die-cast

Replacement Parts

No.	Description	Material	AV2000-A	AV3000-A	AV4000-A	AV5000-A
4	Pilot valve assembly* ¹⁾	—	See below.		See below.	
5	Valve assembly	Rubber material: HNBR	AV22P-060AS		AV42P-060AS	AV52P-060AS
6	Control valve assembly	—	AV22P-110AS		AV42P-110AS	AV52P-110AS
7	Piston assembly	POM, NBR	AV22P-120AS		AV42P-120AS	AV52P-120AS
8	Needle assembly	POM, NBR	AV22P-150AS	AV22P-150AS	AV22P-150AS	AV22P-150AS
9	Plug assembly* ²⁾	POM, NBR	AR22P-320AS-□01			
10	Valve spring	Stainless steel	AV22P-170		AV42P-170	AV52P-170
11	Piston spring	Stainless steel	AV22P-190		AV42P-190	AV52P-190
12	Damper	Urethane	AV22P-230		AV42P-230	AV52P-230

*1 See page 20 and 21 for How to Order of the pilot valve.

*2 □ of plug assembly will indicate the connecting screw type. No indication is necessary for R; however, indicate N for NPT.

Optional Parts Nos.

Series	AV2000-A	AV3000-A	AV4000-A	AV5000-A
Bracket Assembly ^{*1}	AV22P-210AS	AV32P-210AS	AV42P-210AS	AV52P-210AS
Silencer Assembly ^{*2}	AV22P-250AS	AV32P-250AS	AV42P-250AS	AV52P-250AS
Pressure gauge ^{*3}	G36-10-□01			
Pressure gauge (MPa/psi dual scale) ^{*4}	G36-P10-N01-X30			

*1 Bracket: 1 pc., Mounting screw: 2 pcs. (3pcs for AV5000-A)

*2 Element, Element O-ring, Element cover: 1 pc. For each

*3 The □ in the pressure gauge part number indicates the type of connection thread. No indication is necessary for R; however, indicate "N" for NPT.

*4 For the pressure unit : Z

This product is for overseas use only according to the New Measurement Act. (The SI unit type is provided for use in Japan.)

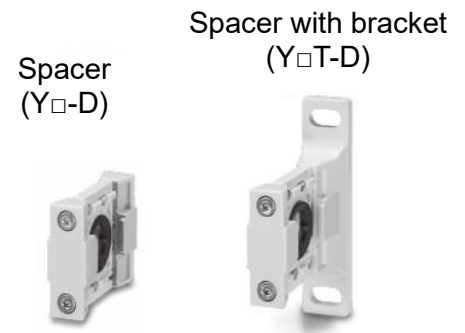

Connecting Spacer for Modular Type F.R.L. Unit

Series	AV2000-A	AV3000-A	AV4000-A	AV5000-A
Spacer	Y200-D	Y300-D	Y400-D	Y600-D
Spacer with bracket	Y200T-D	Y300T-D	Y400T-D	Y600T-D
Applicable model	AC20-D	AC30-D	AC40-D ^{*1}	AC50-D AC60-D

*1 Excludes port size 06

* The AC-A series and the B series can also be connected.

Assembly Example

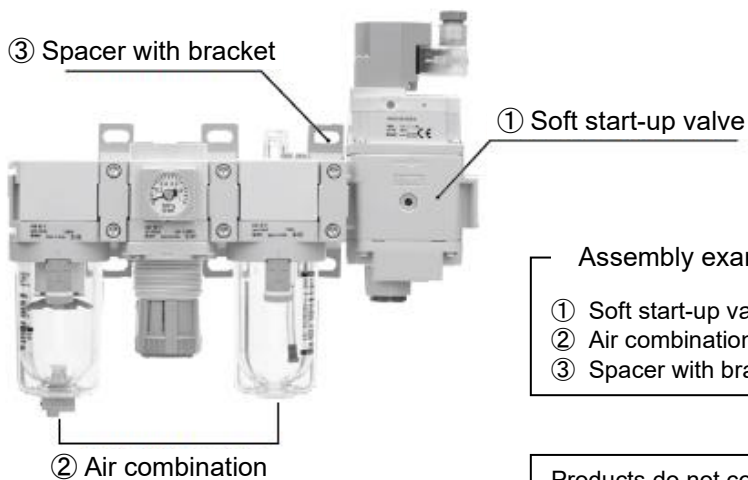

Assembly example

- ① Soft start-up valve: AV3000-03S-5DZB-A 1 pc.
- ② Air combination: AC30-03E-D 1 pc.
- ③ Spacer with bracket: Y300T-D 1 pc.

Products do not come assembled. They should be ordered separately and assembled by the customer.

* The Simple Special System deals with product unification. Please contact your local sales representative for more details.

6. Assembly of Optional parts

(1) Bracket assembly

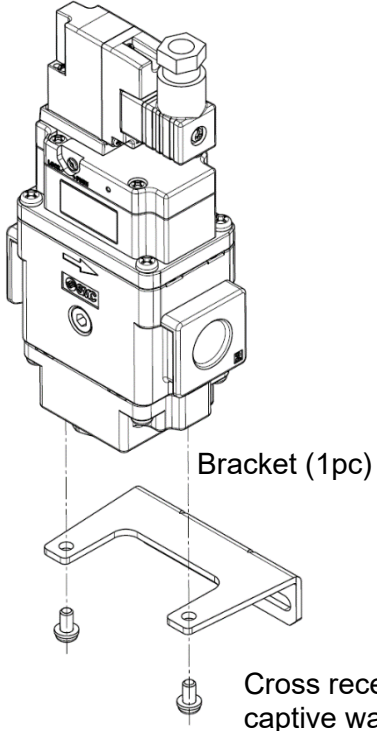

Bracket (1pc)

Cross recessed head screw with captive washer (2pcs)

- 1) Installation of bracket
Align two holes of the bracket with the holes at the bottom of the product. See drawing of the left. (3 holes for AV5000-A)
- 2) Tightening of screw
Insert the mounting screw (cross recessed head screw with captive washer) to the holes of the product at the opposite side of the bracket, and tighten the screw to hold the bracket.

* Use a Phillips screwdriver for tightening the screw.

Bracket assembly part no.	Cross recessed head screw size	Thread Qty
AV22P-210AS	M4x14	2 pcs
AV32P-210AS	M4x14	2 pcs
AV42P-210AS	M5x16	2 pcs
AV52P-210AS	M6x20	3 pcs

(2) Silencer assembly

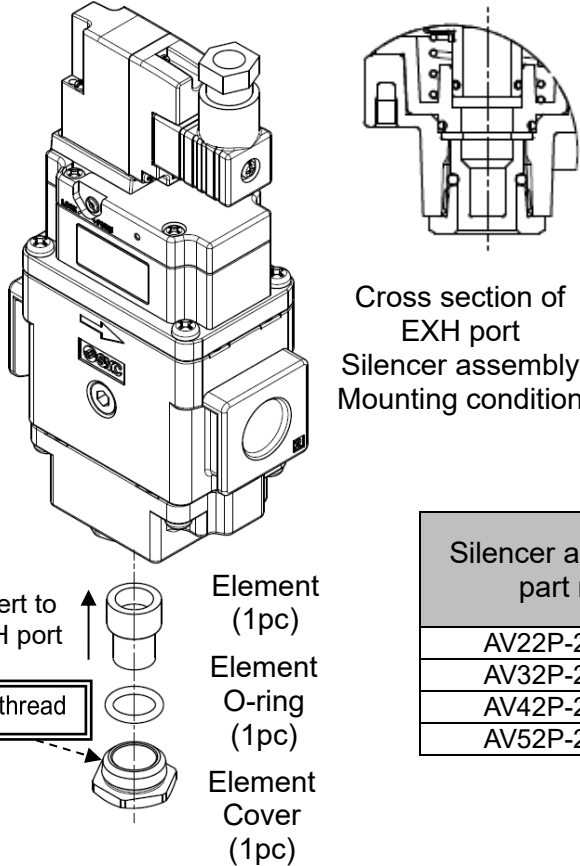

Cross section of EXH port
Silencer assembly
Mounting condition

- 1) Mounting of the element
After inserting the element o-ring to the element, insert the element to EXH port.
- 2) Tightening of the screw of element cover
Mount the element cover to the female thread of EXH port.

* The male thread of the element cover is Uni-thread. It is applicable to all thread types of Rc/G/NPT.
* Refer to the table below for the tightening torque of the element.

Silencer assembly part no.	Uni-thread size	Tightening Torque [N·m]	Noise Reduction [dB] *1
AV22P-250AS	Uni1/4	4 to 5	21
AV32P-250AS	Uni3/8	8 to 9	25
AV42P-250AS	Uni1/2	14 to 15	26
AV52P-250AS	Uni3/4	22 to 24	26

*1 Reference data

7. Working Principle

Working conditions	Pilot valve	Pressure conditions	Operation description	Internal construction/Cylinder actuation circuit (Meter-out control) example
Low Speed air supply		$P_S > P_A$	<p><u>Operation description of the soft start-up valve</u> When the pilot valve ① is energized or turned ON manually, the spool ② is pushed down due to the pilot air and gets into contact with the valve ③, closing the flow passage to port 3 (R). At this time, force that pushed the valve ③ \geq force that pushed down the spool ②. Therefore, the flow passage from the valve ③ to port 2 (A) is still closed. Furthermore, the piston ④ is pushed down due to the pilot air, and the flow passage from the needle ⑤ to port 2 (A) opens. And then, the air pressure whose flow rate is adjusted by the needle ⑤ flows to port 2 (A).</p> <p><u>Description of cylinder actuation</u> The meter-in control of the needle ⑤ slowly moves the cylinder from A to B.</p> <p>P_P: Inlet pressure P_A: Outlet pressure</p>	
High Speed air supply	ON	$P_S \leq P_A$	<p><u>Operation description of the soft start-up valve</u> When the outlet side is filled with pressure supplied from the needle ⑤, P_A increased. When P_A exceeds the specified pressure, the force that pushed up the valve ③ becomes smaller than the force that pushed down the spool ②. Then, the valve ③ is pushed down, opening the flow passage, and pressure is supplied to port 2 (A).</p> <p><u>Description of cylinder actuation</u> When $P_S < P_A$ after the cylinder reaches B, the mail valve fully opens and P_A increase rapidly as shown C to D and becomes the same pressure as P_P.</p> <p>P_S: Pressure for switching to rapid air supply</p>	
Normal operation		$P_S \doteq P_A$	<p><u>Operation description of the soft start-up valve</u> The valve ③ holds the fully open condition.</p> <p><u>Description of cylinder actuation</u> The cylinder operation is controlled by a meter-out circuit on the cylinder side.</p>	
Exhaust	OFF	—	<p><u>Operation description of the soft start-up valve</u> When the pilot valve ① is turned OFF, the pilot air of the spool ② is exhausted from the pilot valve ①, and the spool ② and valve ③ are returned upward due to the spring. This opens the flow passage to the port 3 (R), exhausting the air pressure on the port 2 (A) side. The pilot air of the piston ④ is also exhausted from the pilot valve ①, and the piston ④ is returned upward due to the spring, closing the flow passage from needle ⑤.</p>	

8. Trouble Shooting

Power supply of pilot valve	Phenomenon	Cause	Countermeasure
OFF	Air leaks from 3 (R) port.	<ol style="list-style-type: none"> 1. Inclusion of foreign matter onto sheet surface of the valve assembly. 2. Damage on rubber portion of the valve assembly. 3. Damage of the valve spring. 4. Inclusion of foreign matter onto sheet surface of the piston assembly. 5. Damage on rubber portion of the piston assembly. 6. Damage of the piston spring. 	<ol style="list-style-type: none"> 1. Please air blow the sheet surface of the valve assembly. 2. Please replace the valve assembly. 3. Please replace the valve spring. 4. Please air blow the sheet surface of the piston valve assembly. 5. Please replace the piston valve assembly. 6. Please replace the piston spring.
	The residual pressure is not exhausted.	<ol style="list-style-type: none"> 1. Manual override position of the pilot valve assembly is ON. 2. Failure of the pilot valve assembly. 3. Damage of the spool spring. 	<ol style="list-style-type: none"> 1. Please switch the manual override OFF. 2. Please replace the pilot valve assembly. 3. Please replace the control valve assembly.
ON	Air is not supplied to 2 (A) port. (There is no leakage from 3 (R) port.)	<ol style="list-style-type: none"> 1. Decrease of the operation pressure. 2. Failure of the pilot valve assembly. 3. Condition of the needle operation is closed. 	<ol style="list-style-type: none"> 1. Please supply the operating pressure within 0.2 to 1.0MPa. 2. Please replace the pilot valve assembly. 3. Please turn the needle to the open direction (“+” direction).
	Air is not supplied to 2 (A) port. (There is a leakage from 3 (R) port.)	<ol style="list-style-type: none"> 1. Decrease of the operation pressure. 2. Air supply capacity from 1 (P) port is not sufficiency. (Combined sonic conductance is too small) 	<ol style="list-style-type: none"> 1. Please supply the operating pressure within 0.2 to 1.0MPa. 2. Please refer to the precaution of “PIPING”, and review the piping and the equipment on the upstream side.
	Air leaks from 3 (R) port. (small amount of leakage)	<ol style="list-style-type: none"> 1. Inclusion of foreign matter onto sheet surface of the control valve assembly. 2. Damage on rubber portion of the control valve assembly. 3. Inclusion of foreign matter onto sheet surface of the valve assembly. 4. Damage on rubber portion of the valve assembly. 	<ol style="list-style-type: none"> 1. Please air blow the sheet surface of the control valve assembly. 2. Please replace the control valve assembly. 3. Please air blow the sheet surface of the valve assembly. 4. Please replace the valve assembly.
	Flow adjustment by the switching operation of the needle (open/close) cannot be done. (Air leaks from 2 (A) port even if the needle is closed.)	<ol style="list-style-type: none"> 1. Inclusion of foreign matter onto sheet surface of the control valve assembly. 2. Damage on rubber portion of the control valve assembly. 	<ol style="list-style-type: none"> 1. Please air blow the sheet surface of the control valve assembly. 2. Please replace the control valve assembly.

9. Disassembly drawing

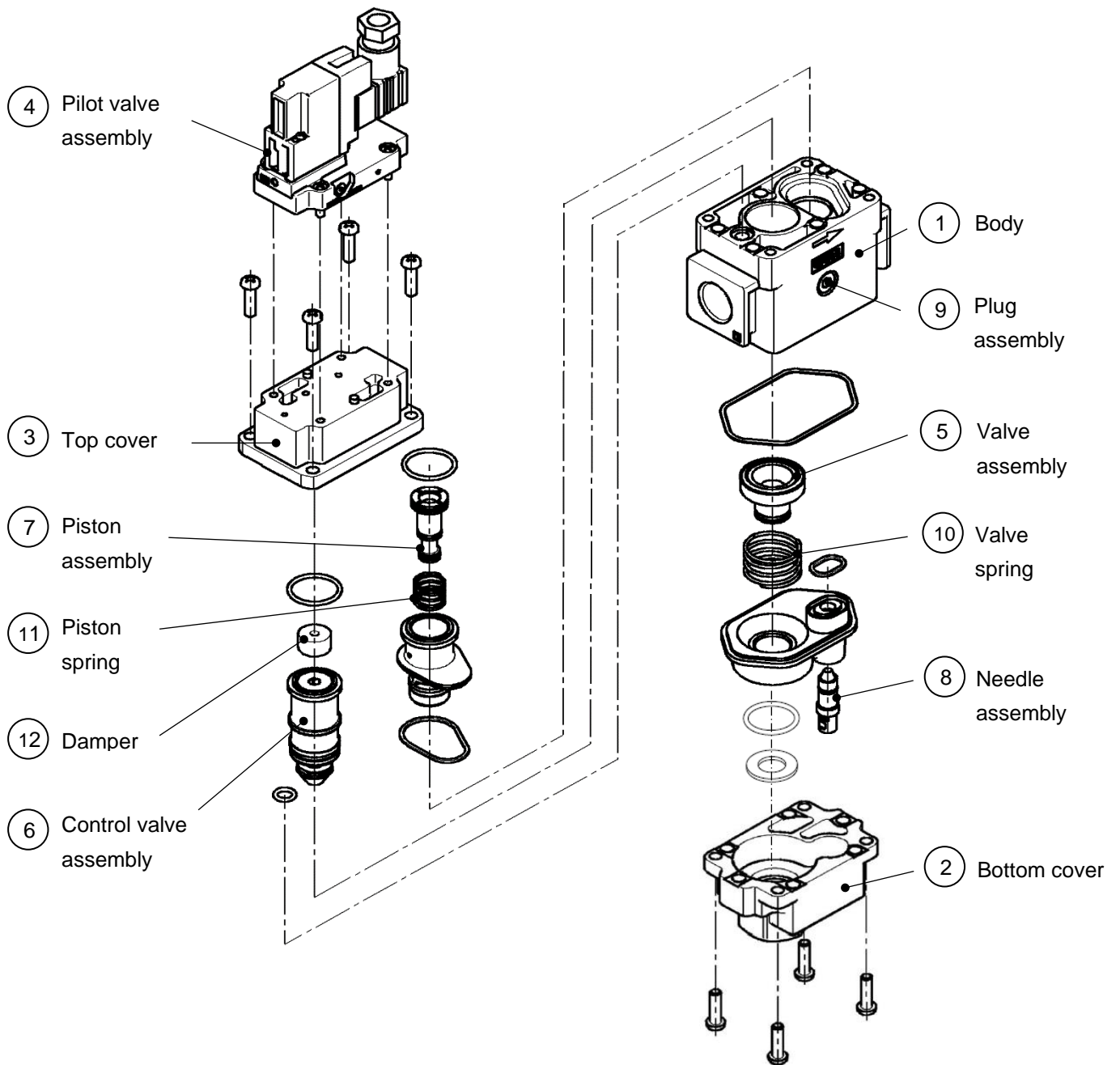

9. Dimensions

Grommet: AV□00-□-□G□-□-A

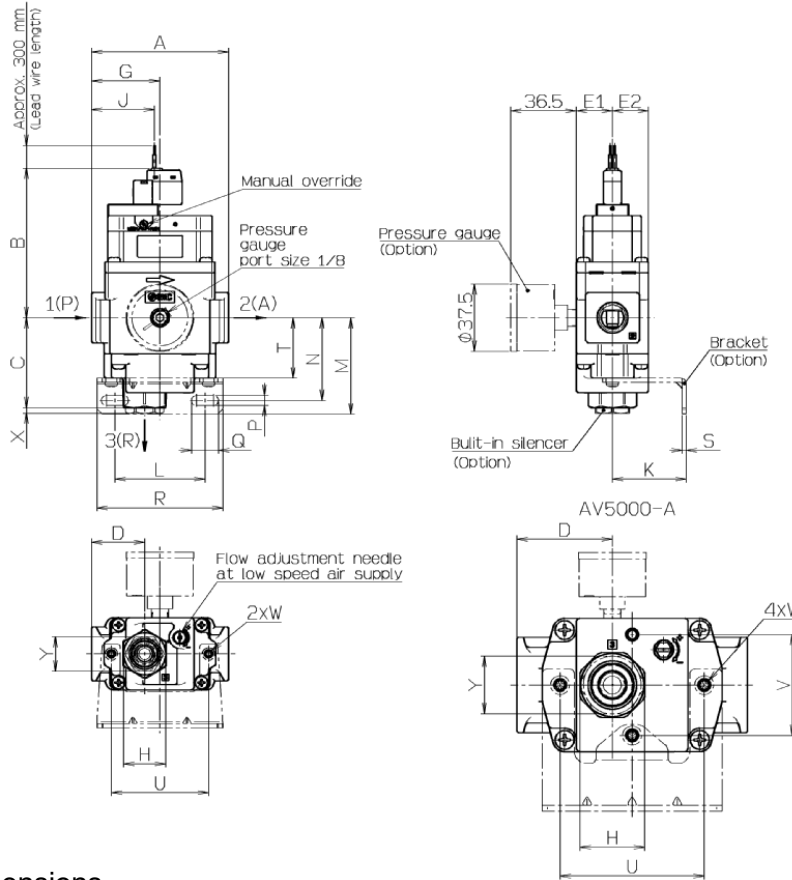

(mm)

Body size	Coil type	B
20	AC	85
	DC	83
30	AC	85
	DC	83
40	AC	95
	DC	93
50	AC	98
	DC	96

Dimensions

(mm)

Model	Standard specifications										
	Port size			A	C	D	E1	E2	G	H	J
	1(P)	2(A)	3(R)								
AV2000-□02-1 to 4G(Z)□-A	1/4	1/4	1/4	66	47	24.5	20	20	33	Width across flats 22	30
AV2000-□02-5 to 6G(Z)□-A	1/4	1/4	1/4								
AV3000-□03-1 to 4G(Z)□-A	3/8	3/8	3/8	76	50	29.5	20	20	38	Width across flats 24	35
AV3000-□03-5 to 6G(Z)□-A	3/8	3/8	3/8								
AV4000-□04-1 to 4G(Z)□-A	1/2	1/2	1/2	98	56	39.5	26	26	49	Width across flats 30	33
AV4000-□04-5 to 6G(Z)□-A	1/2	1/2	1/2								
AV5000-□06,10-1 to 4G(Z)□-A	3/4,1	3/4,1	3/4	128	59	53	37	37	53	Width across flats 36	52
AV5000-□06,10-5 to 6G(Z)□-A	3/4,1	3/4,1	3/4								

Model	Optional specifications													
	With bracket												With built-in silencer	
	K	L	M	N	P	Q	R	S	T	U	V	W	X	Y
AV2000-□02-1 to 4G(Z)□-A	30	50	51.5	44	5.5	10	66	2.3	33.5	54	—	M4 x 0.7 Depth 6	3	Width across flats 14
AV2000-□02-5 to 6G(Z)□-A														
AV3000-□03-1 to 4G(Z)□-A	41	50	53.5	46	5.5	15	70	2.3	33.5	54	—	M4 x 0.7 Depth 6	3	Width across flats 19
AV3000-□03-5 to 6G(Z)□-A														
AV4000-□04-1 to 4G(Z)□-A	50	60	64	54	8.5	18	90	3.2	39	74	—	M5 x 0.8 Depth 6.5	4	Width across flats 22
AV4000-□04-5 to 6G(Z)□-A														
AV5000-□06,10-1 to 4G(Z)□-A	70	75	70	60	11	16	100	3.2	45	80	56	M6 x 1 Depth 8	6	Width across flats 32
AV5000-□06,10-5 to 6G(Z)□-A														

DIN terminal: AV□00-□-□D/Y□-□-A

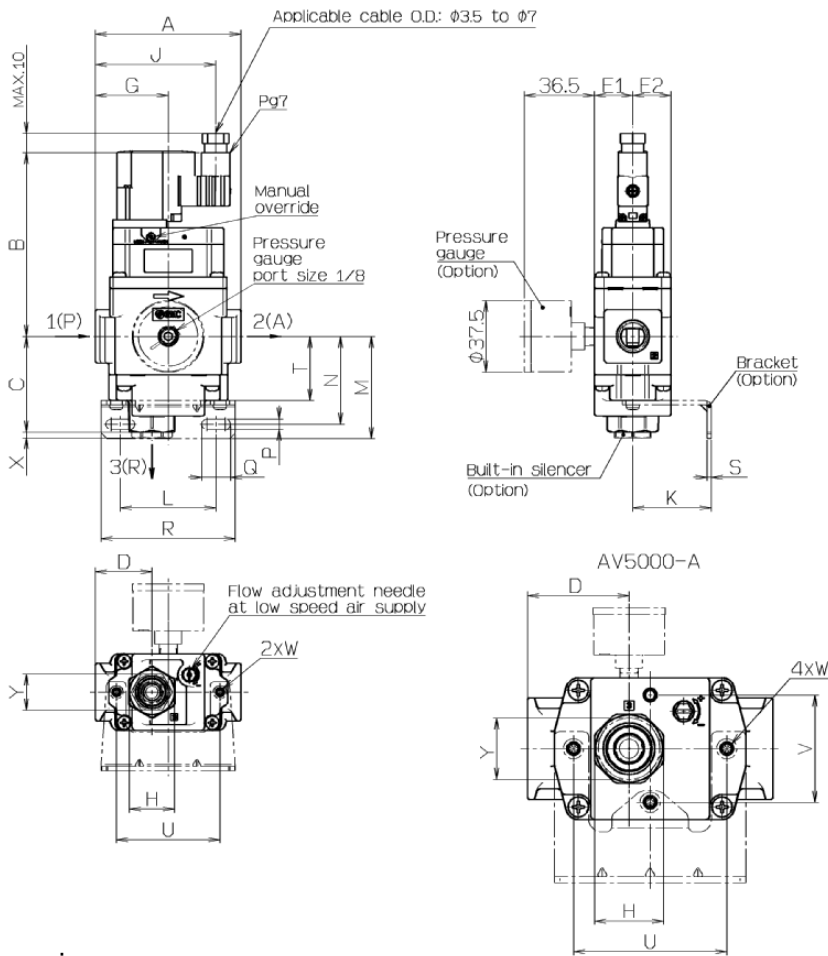

Dimensions

(mm)

Model	Standard specifications											
	Port size			A	B	C	D	E1	E2	G	H	J
	1(P)	2(A)	3(R)									
AV2000-□02-1 to 6D/Y(Z)□-A	1/4	1/4	1/4	66	97	47	24.5	20	20	33	Width across flats 22	58
AV3000-□03-1 to 6D/Y(Z)□-A	3/8	3/8	3/8	76	97	50	29.5	20	20	38	Width across flats 24	63
AV4000-□04-1 to 6D/Y(Z)□-A	1/2	1/2	1/2	98	107	56	39.5	26	26	49	Width across flats 30	61
AV5000-□06,10-1 to 6D/Y(Z)□-A	3/4,1	3/4,1	3/4	128	109	59	53	37	37	53	Width across flats 36	80

Model	Optional specifications													
	With bracket											With built-in silencer		
	K	L	M	N	P	Q	R	S	T	U	V	W	X	Y
AV2000-□02-1 to 6D/Y(Z)□-A	30	50	51.5	44	5.5	10	66	2.3	33.5	54	—	M4 x 0.7 Depth 6	3	Width across flats 14
AV3000-□03-1 to 6D/Y(Z)□-A	41	50	53.5	46	5.5	15	70	2.3	33.5	54	—	M4 x 0.7 Depth 6	3	Width across flats 19
AV4000-□04-1 to 6D/Y(Z)□-A	50	60	64	54	8.5	18	90	3.2	39	74	—	M5 x 0.8 Depth 6.5	4	Width across flats 22
AV5000-□06,10-1 to 6D/Y(Z)□-A	70	75	70	60	11	16	100	3.2	45	80	56	M6 x 1 Depth 8	6	Width across flats 32

M12 connector: AV□00-□-□KOZ-□-A

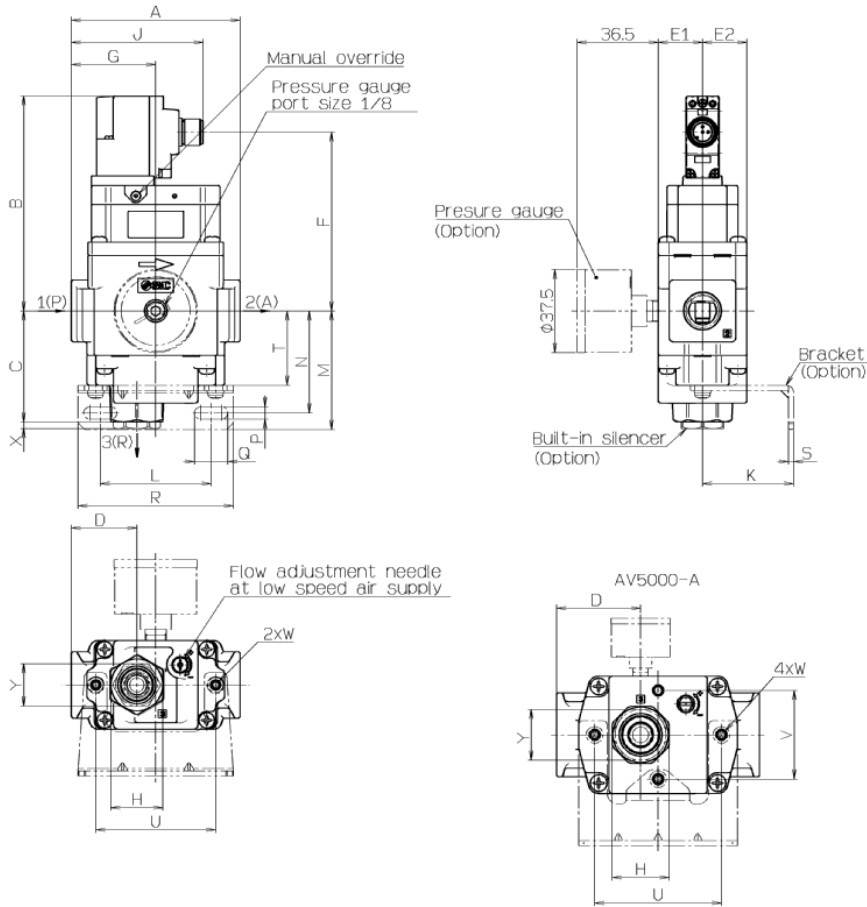

Dimensions

(mm)

Model	Standard specifications												
	Port size			A	B	C	D	E1	E2	F	G	H	J
	1(P)	2(A)	3(R)										
AV2000-□02-5,6KOZ-□-A	1/4	1/4	1/4	66	97	47	24.5	20	20	81	33	Width across flats 22	58
AV3000-□03-5,6KOZ-□-A	3/8	3/8	3/8	76	97	50	29.5	20	20	81	38	Width across flats 24	63
AV4000-□04-5,6KOZ-□-A	1/2	1/2	1/2	98	107	56	39.5	26	26	91	49	Width across flats 30	61
AV5000-□06,10-5,6KOZ-□-A	3/4,1	3/4,1	3/4	128	109	59	53	37	37	94	53	Width across flats 36	80

Model	Optional specifications													
	With bracket											With built-in silencer		
	K	L	M	N	P	Q	R	S	T	U	V	W	X	Y
AV2000-□02-5,6KOZ-□-A	30	50	51.5	44	5.5	10	66	2.3	33.5	54	—	M4 x 0.7 Depth 6	3	Width across flats 14
AV3000-□03-5,6KOZ-□-A	41	50	53.5	46	5.5	15	70	2.3	33.5	54	—	M4 x 0.7 Depth 6	3	Width across flats 19
AV4000-□04-5,6KOZ-□-A	50	60	64	54	8.5	18	90	3.2	39	74	—	M5 x 0.8 Depth 6.5	4	Width across flats 22
AV5000-□06,10-5,6KOZ-□-A	70	75	70	60	11	16	100	3.2	45	80	56	M6 x 1 Depth 8	6	Width across flats 32

Air operated type: AVA□00-□-□-A

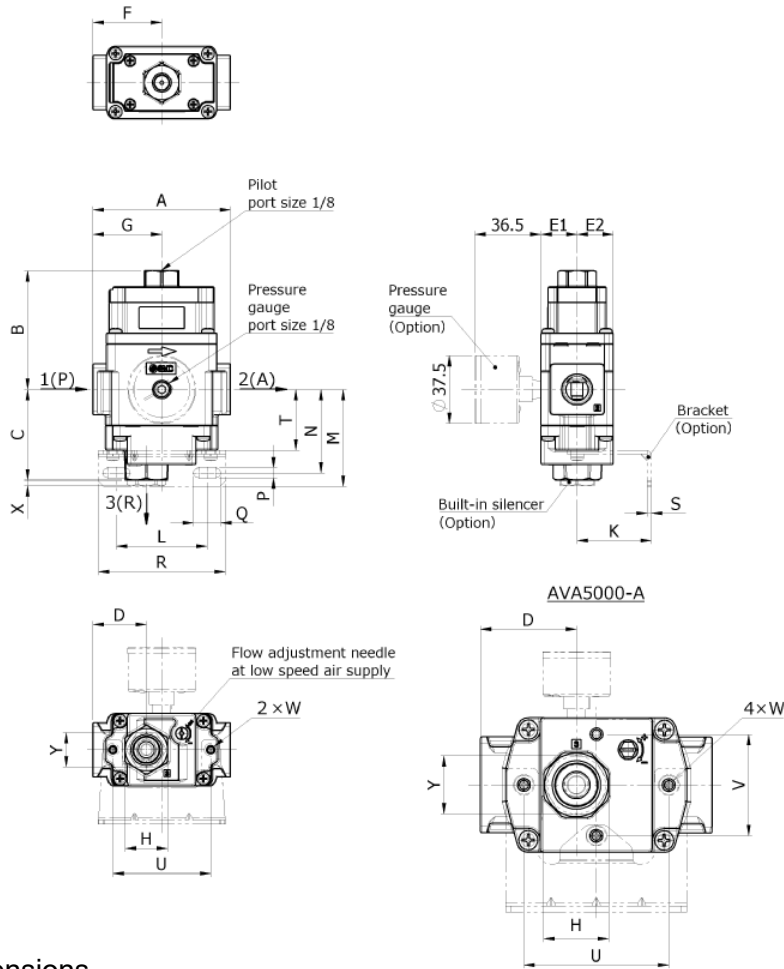

Dimensions

(mm)

Model	Standard specifications												
	Port size			Pilot Port size	A	B	C	D	E1	E2	F	G	H
	1(P)	2(A)	3(R)		66	65.6	47	24.5	20	20	33	33	Width across flats 22
AVA2000-□02-□-A	1/4	1/4	1/4	1/8	66	65.6	47	24.5	20	20	33	33	Width across flats 22
AVA3000-□03-□-A	3/8	3/8	3/8	1/8	76	65.6	50	29.5	20	20	38	38	Width across flats 24
AVA4000-□04-□-A	1/2	1/2	1/2	1/8	98	75.6	56	39.5	26	26	36	49	Width across flats 30
AVA5000-□06,10-□-A	3/4,1	3/4,1	3/4	1/8	128	78.6	59	53	37	37	55	53	Width across flats 36

Model	Optional specifications													
	With bracket												With built-in silencer	
	K	L	M	N	P	Q	R	S	T	U	V	W	X	Y
AVA2000-□02-□-A	30	50	51.5	44	5.5	10	66	2.3	33.5	54	—	M4 x 0.7 Depth 6	3	Width across flats 14
AVA3000-□03-□-A	41	50	53.5	46	5.5	15	70	2.3	33.5	54	—	M4 x 0.7 Depth 6	3	Width across flats 19
AVA4000-□04-□-A	50	60	64	54	8.5	18	90	3.2	39	74	—	M5 x 0.8 Depth 6.5	4	Width across flats 22
AVA5000-□06,10-□-A	70	75	70	60	11	16	100	3.2	45	80	56	M6 x 1 Depth 8	6	Width across flats 32

Lockout type (Manual operation): AVL□00-□-□-A

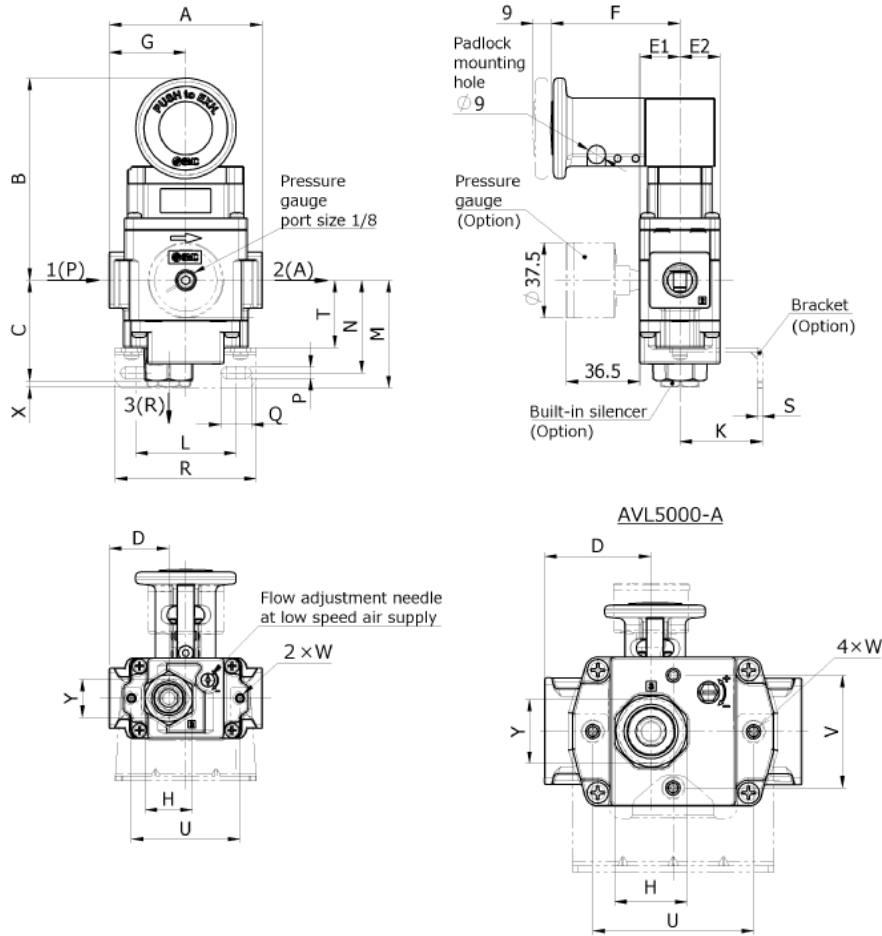

Dimensions

(mm)

Model	Standard specifications											H
	Port size			A	B	C	D	E1	E2	F	G	
	1(P)	2(A)	3(R)									
AVL2000-□02-□-A	1/4	1/4	1/4	66	100.6	47	24.5	20	20	64	33	Width across flats 22
AVL3000-□03-□-A	3/8	3/8	3/8	76	100.6	50	29.5	20	20	64	38	Width across flats 24
AVL4000-□04-□-A	1/2	1/2	1/2	98	110.6	56	39.5	26	26	64	49	Width across flats 30
AVL5000-□06,10-□-A	3/4,1	3/4,1	3/4	128	113.6	59	53	37	37	64	53	Width across flats 36

Model	Optional specifications													
	With bracket												With built-in silencer	
	K	L	M	N	P	Q	R	S	T	U	V	W	X	Y
AVL2000-□02-□-A	30	50	51.5	44	5.5	10	66	2.3	33.5	54	—	M4 x 0.7 Depth 6	3	Width across flats 14
AVL3000-□03-□-A	41	50	53.5	46	5.5	15	70	2.3	33.5	54	—	M4 x 0.7 Depth 6	3	Width across flats 19
AVL4000-□04-□-A	50	60	64	54	8.5	18	90	3.2	39	74	—	M5 x 0.8 Depth 6.5	4	Width across flats 22
AVL5000-□06,10-□-A	70	75	70	60	11	16	100	3.2	45	80	56	M6 x 1 Depth 8	6	Width across flats 32

Lockout type (Manual operation with solenoid valve)

DIN terminal: AVL□00-□-□D/Y□-□-A

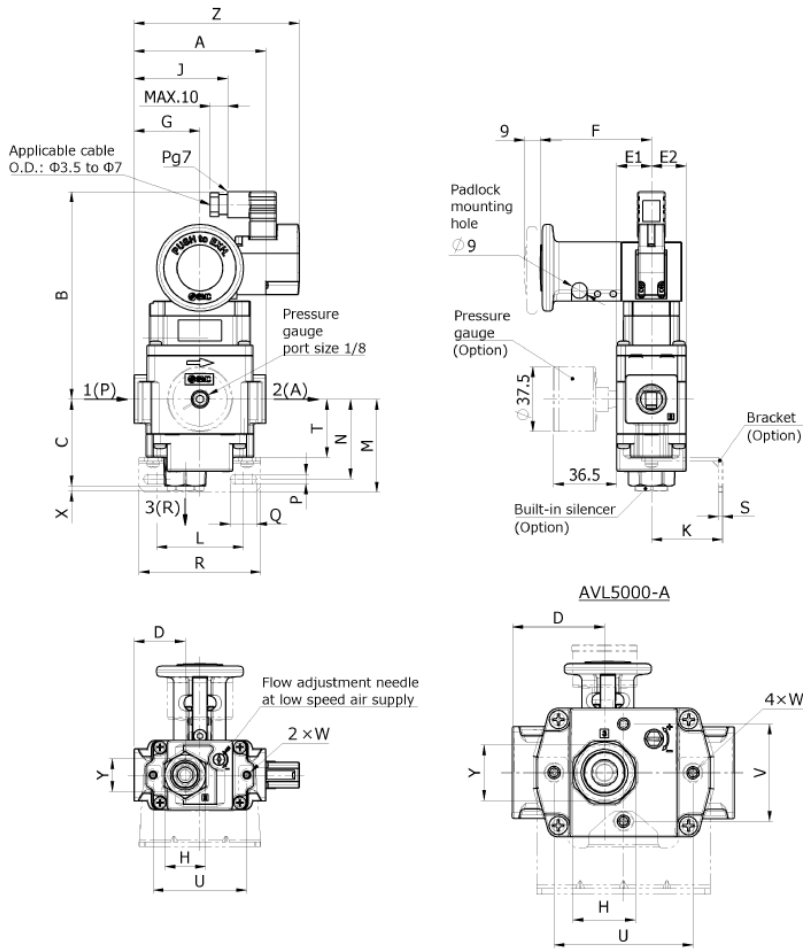

Dimensions

(mm)

Model	Standard specifications													
	Port size			A	B	C	D	E1	E2	F	G	H	J	Z
	1(P)	2(A)	3(R)											
AVL2000-□02-1 to 6D/Y(Z)-□-A	1/4	1/4	1/4	66	119.5	47	24.5	20	20	64	33	Width across flats 22	48.9	90.3
AVL3000-□03-1 to 6D/Y(Z)-□-A	3/8	3/8	3/8	76	119.5	50	29.5	20	20	64	38	Width across flats 24	53.9	95.3
AVL4000-□04-1 to 6D/Y(Z)-□-A	1/2	1/2	1/2	98	129.5	56	39.5	26	26	64	49	Width across flats 30	51.9	93.3
AVL5000-□06,10-1 to 6D/Y(Z)-□-A	3/4·1	3/4·1	3/4	128	132.5	59	53	37	37	64	53	Width across flats 36	70.9	112.3

Model	Optional specifications													
	With bracket												With built-in silencer	
	K	L	M	N	P	Q	R	S	T	U	V	W	X	Y
AVL2000-□02-1 to 6D/Y(Z)-□-A	30	50	51.5	44	5.5	10	66	2.3	33.5	54	—	M4 x 0.7 Depth 6	3	Width across flats 14
AVL3000-□03-1 to 6D/Y(Z)-□-A	41	50	53.5	46	5.5	15	70	2.3	33.5	54	—	M4 x 0.7 Depth 6	3	Width across flats 19
AVL4000-□04-1 to 6D/Y(Z)-□-A	50	60	64	54	8.5	18	90	3.2	39	74	—	M5 x 0.8 Depth 6.5	4	Width across flats 22
AVL5000-□06,10-1 to 6D/Y(Z)-□-A	70	75	70	60	11	16	100	3.2	45	80	56	M6 x 1 Depth 8	6	Width across flats 32

Lockout type (Manual operation with solenoid valve)

M12 connector: AVL□00-□-□KOZ-□-A

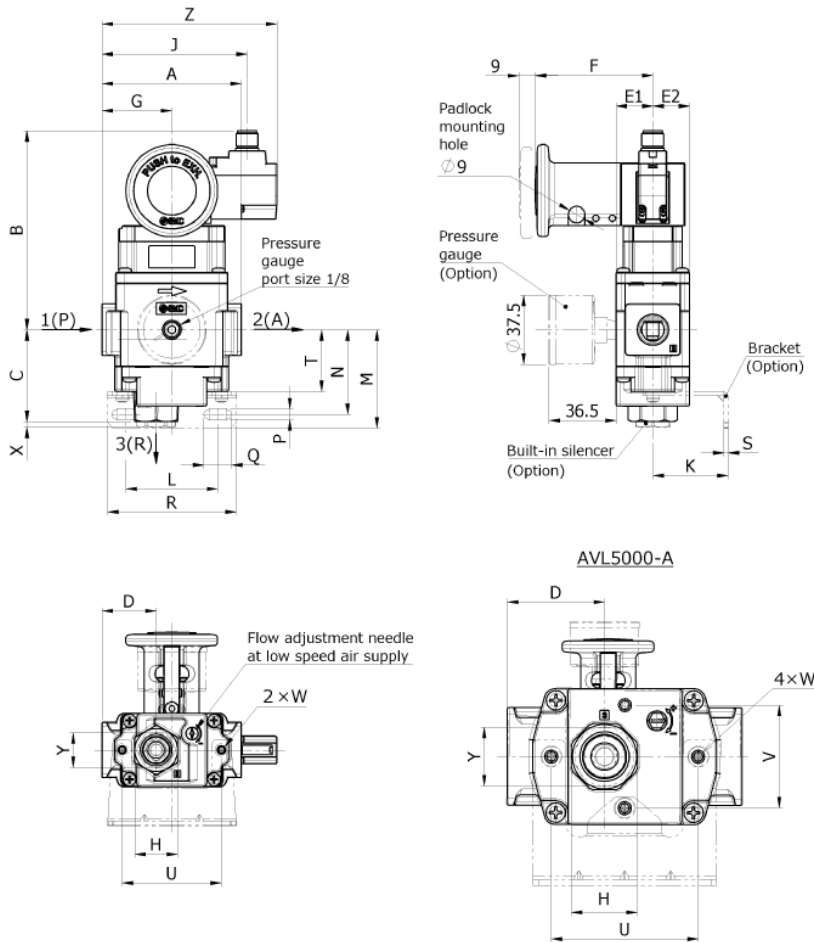

(mm)

Dimensions

Model	Standard specifications													
	Port size			A	B	C	D	E1	E2	F	G	H	J	Z
	1(P)	2(A)	3(R)											
AVL2000-□02-5, 6KOZ-□-A	1/4	1/4	1/4	66	108.1	47	24.5	20	20	64	33	Width across flats 22	74	90.3
AVL3000-□03-5, 6KOZ-□-A	3/8	3/8	3/8	76	108.1	50	29.5	20	20	64	38	Width across flats 24	79	95.3
AVL4000-□04-5, 6KOZ-□-A	1/2	1/2	1/2	98	118.1	56	39.5	26	26	64	49	Width across flats 30	77	93.3
AVL5000-□06,10-5,6KOZ-□-A	3/4·1	3/4·1	3/4	128	121.1	59	53	37	37	64	53	Width across flats 36	96	112.3

Model	Optional specifications													
	With bracket												With built-in silencer	
	K	L	M	N	P	Q	R	S	T	U	V	W	X	Y
AVL2000-□02-5,6KOZ-□-A	30	50	51.5	44	5.5	10	66	2.3	33.5	54	—	M4 x 0.7 Depth 6	3	Width across flats 14
AVL3000-□03-5,6KOZ-□-A	41	50	53.5	46	5.5	15	70	2.3	33.5	54	—	M4 x 0.7 Depth 6	3	Width across flats 19
AVL4000-□04-5,6KOZ-□-A	50	60	64	54	8.5	18	90	3.2	39	74	—	M5 x 0.8 Depth 6.5	4	Width across flats 22
AVL5000-□06,10-5,6KOZ-□-A	70	75	70	60	11	16	100	3.2	45	80	56	M6 x 1 Depth 8	6	Width across flats 32

Revision history

- A** Correction of errors (P32,P33)
- B** Change : Construction and
Disassembly drawing
- C** Change : AVL M12 Connector
Symbol (WO→KO)
Recommended tightening torque (P6)
Dimension "J" (P29)
Add : AV UL certification
Caution (P10)
- D** Add : AV M12 Connector
- E** Change : Safety Instructions (P2,3)
Add : Pressure gauge part number
Selection 8.Extended periods of
continuous energization
SMC's Lead Wire Specifications

SMC Corporation

Tel: + 81 3 5207 8249 Fax: +81 3 5298 5362
URL <https://www.smcworld.com>

Note: Specifications are subject to change without prior notice and any obligation on the part of the manufacturer.
© SMC Corporation All Rights Reserved