



Operation Manual

PRODUCT NAME

Speed Controller Adjustable by Flat Head
Screwdriver with One-touch Fitting
In-line Type

MODEL / Series / Product Number

A S □ □ □ 1F-D

SMC Corporation

Contents

1.Safety Instructions	2~3
2.Specific Product Precautions	4~6
3.Applications	7
4.Specifications	7
5.Troubleshooting	7
6.Construction	8



Speed Controller Adjustable by Flat Head Screwdriver with One-touch Fitting In-line Type

Safety Instructions

These safety instructions are intended to prevent hazardous situations and/or equipment damage. These instructions indicate the level of potential hazard with the labels of “**Caution**,” “**Warning**” or “**Danger**.” They are all important notes for safety and must be followed in addition to International Standards (ISO/IEC)^{*1)}, and other safety regulations.

*1) ISO 4414: Pneumatic fluid power - General rules and safety requirements for systems and their components
ISO 4413: Hydraulic fluid power - General rules and safety requirements for systems and their components
IEC 60204-1: Safety of machinery - Electrical equipment of machines - Part 1: General requirements
ISO 10218-1: Robots and robotic devices - Safety requirements for industrial robots - Part 1: Robots
etc.



Danger

Danger indicates a hazard with a high level of risk which, if not avoided, will result in death or serious injury.

Warning

Warning indicates a hazard with a medium level of risk which, if not avoided, could result in death or serious injury.

Caution

Caution indicates a hazard with a low level of risk which, if not avoided, could result in minor or moderate injury.

Warning

1. The compatibility of the product is the responsibility of the person who designs the equipment or decides its specifications.

Since the product specified here is used under various operating conditions, its compatibility with specific equipment must be decided by the person who designs the equipment or decides its specifications based on necessary analysis and test results. The expected performance and safety assurance of the equipment will be the responsibility of the person who has determined its compatibility with the product. This person should also continuously review all specifications of the product referring to its latest catalog information, with a view to giving due consideration to any possibility of equipment failure when configuring the equipment.

2. Only personnel with appropriate training should operate machinery and equipment.

The product specified here may become unsafe if handled incorrectly. The assembly, operation and maintenance of machines or equipment including our products must be performed by an operator who is appropriately trained and experienced.

3. Do not service or attempt to remove product and machinery/equipment until safety is confirmed.

1. The inspection and maintenance of machinery/equipment should only be performed after measures to prevent falling or runaway of the driven objects have been confirmed.
2. When the product is to be removed, confirm that the safety measures as mentioned above are implemented and the power from any appropriate source is cut, and read and understand the specific product precautions of all relevant products carefully.
3. Before machinery/equipment is restarted, take measures to prevent unexpected operation and malfunction.

4. Our products cannot be used beyond their specifications. Our products are not developed, designed, and manufactured to be used under the following conditions or environments. Use under such conditions or environments is not covered.

1. Conditions and environments outside of the given specifications, or use outdoors or in a place exposed to direct sunlight.
2. Use for nuclear power, railways, aviation, space equipment, ships, vehicles, military application, equipment affecting human life, body, and property, fuel equipment, entertainment equipment, emergency shut-off circuits, press clutches, brake circuits, safety equipment, etc., and use for applications that do not conform to standard specifications such as catalogs and operation manuals.
3. Use for interlock circuits, except for use with double interlock such as installing a mechanical protection function in case of failure. Please periodically inspect the product to confirm that the product is operating properly.



Speed Controller Adjustable by Flat Head Screwdriver with One-touch Fitting In-line Type

Safety Instructions

Caution

We develop, design, and manufacture our products to be used for automatic control equipment, and provide them for peaceful use in manufacturing industries.

Use in non-manufacturing industries is not covered.

Products we manufacture and sell cannot be used for the purpose of transactions or certification specified in the Measurement Act.

The new Measurement Act prohibits use of any unit other than SI units in Japan.

Limited warranty and Disclaimer/Compliance Requirements

The product used is subject to the following "Limited warranty and Disclaimer" and "Compliance Requirements". Read and accept them before using the product.

Limited warranty and Disclaimer

1. The warranty period of the product is 1 year in service or 1.5 years after the product is delivered, whichever is first.*2)
Also, the product may have specified durability, running distance or replacement parts. Please consult your nearest sales branch.
2. For any failure or damage reported within the warranty period which is clearly our responsibility, a replacement product or necessary parts will be provided.
This limited warranty applies only to our product independently, and not to any other damage incurred due to the failure of the product.
3. Prior to using SMC products, please read and understand the warranty terms and disclaimers noted in the specified catalog for the particular products.

***2) Vacuum pads are excluded from this 1 year warranty.**

A vacuum pad is a consumable part, so it is warranted for a year after it is delivered.

Also, even within the warranty period, the wear of a product due to the use of the vacuum pad or failure due to the deterioration of rubber material are not covered by the limited warranty

Compliance Requirements

1. The use of SMC products with production equipment for the manufacture of weapons of mass destruction (WMD) or any other weapon is strictly prohibited.
2. The exports of SMC products or technology from one country to another are governed by the relevant security laws and regulations of the countries involved in the transaction. Prior to the shipment of a SMC product to another country, assure that all local rules governing that export are known and followed.

2. Specific Product Precautions

Design / Selection

warning

- 1. Confirm the specifications.**

Products represented in this catalog are designed only for use in compressed air systems (including vacuum).
Do not operate at pressures or temperatures, etc., beyond the range of specifications, as this can cause damage or malfunction.
(Refer to the specifications.)
We do not guarantee against any damage if the product is used outside of the specification range.
- 2. Products mentioned in this catalog are not designed for the use as stop valve with zero air leakage.**

A certain amount of leakage is allowed in the product's specifications. Tightening the needle to reduce leakage to zero may result in equipment damage.
- 3. Do not disassemble the product or make any modifications, including additional machining.**

It may cause human injury and/or an accident.
- 4. The flow characteristics for each product are representative values.**

The flow characteristics are characteristics of each individual product. Actual values may differ depending on the piping, circuitry, pressure conditions, etc. Also, there are variations in the zero needle rotations position of the flow characteristics, depending on product specifications.

Mounting

warning

- 1. Operation manual**

Install the product and operate it only after reading the operation manual carefully and understanding its contents. Also, keep the manual where it can be referred to as necessary.
- 2. Ensure sufficient space for maintenance activities.**

When installing the products, allow access for maintenance.
- 3. Check the degree of rotation of the needle valve.**

The products in catalog are retainer type so that the needle is not removed completely. Over rotation will cause damage.
- 4. Adjust the speed by opening the needle slowly from the fully closed state.**

Loose needle valves may cause unexpected sudden actuator lurching.

When a needle valve is turned clockwise, it is closed and actuator speed decreases. When a needle valve is turned counterclockwise, it is open and actuator speed increases.

- 5. Do not apply excessive force or shock to the body or fittings with an impact tool.**

It can cause damage or air leakage.

Piping

Caution

- 1. Refer to the Fittings and Tubing Precautions for handling one-touch fittings.**
- 2. Preparation before piping**

Before piping is connected, it should be thoroughly blown out with air (flushing) or washed to remove chips, cutting oil and other debris from inside the pipe.

Air Supply

Warning

- 1. Type of fluids**

Use compressed air as the fluid used.
- 2. When there is a large amount of drainage.**

Compressed air containing a large amount of drainage can cause malfunction of pneumatic equipment. An air dryer or water separator should be installed upstream from filters.
- 3. Drain flushing**

If condensation in the drain bowl is not emptied on a regular basis, the bowl will overflow and allow the condensation to enter the compressed air lines. It causes malfunction of pneumatic equipment. If the drain bowl is difficult to check and remove, installation of a drain bowl with an auto drain option is recommended. For compressed air quality, refer to SMC's Best Pneumatics catalog.
- 4. Use clean air.**

Do not use compressed air that contains chemicals, synthetic oils including organic solvents, salt or corrosive gases, etc., as it can cause damage or malfunction.

Caution

- 1. Install an air filter.**

Install an air filter upstream near the valve.
Select an air filter with a filtration size of 5 µm or smaller.
- 2. Take measures to ensure air quality, such as by installing an aftercooler, air dryer, or water separator.**

Compressed air that contains a large amount of

drainage can cause malfunction of pneumatic equipment such as flow control equipment. Therefore, take appropriate measures to ensure air quality, such as by providing an aftercooler, air dryer, or water separator.

3. Ensure that the fluid and ambient temperature are within the specified range.

If the fluid temperature is 5°C or less, the moisture in the circuit could freeze, causing damage to the seals and leading to equipment malfunction. Therefore, take appropriate measures to prevent freezing. For compressed air quality, refer to SMC's Best Pneumatics catalog.

Operating Environment

warning

1. Do not use in an atmosphere having corrosive gases, chemicals, sea water, water, water steam, or where there is direct contact with any of these.

Refer to each construction drawing on the flow control equipment material.

2. Do not expose the product to direct sunlight for an extended period of time.

3. Do not use in a place subject to heavy vibration and/or shock.

4. Do not mount the product in locations where it is exposed to radiant heat.

5. Using a flat blade screwdriver adjustable type tamper proof speed controller in locations where vibrations or impacts occur could lead to loosening of the needle. So please use a hexagon lock nut adjustable type speed controller.

Maintenance

warning

1. Perform maintenance inspection according to the procedures indicated in the operation manual.

If handled improperly, malfunction and damage of machinery or equipment may occur.

2. Maintenance work

If handled improperly, compressed air can be dangerous. Assembly, handling, repair and element replacement of pneumatic systems should be performed by a knowledgeable and experienced person.

3. Drain flushing

Remove drainage from air filters regularly.

4. Removal of equipment, and supply/exhaust of compressed air

When components are removed, first confirm that measures are in place to prevent workpieces from dropping, run-away equipment, etc. Then, cut off the supply pressure and electric power, and exhaust all compressed air from the system using the residual pressure release function.

When machinery is restarted, proceed with caution after confirming that appropriate measures are in place to prevent cylinders from sudden movement.

One-touch Fittings

Mounting / Piping

Caution

1. Tubing insertion and removal from onetouch fittings

1) Attaching of tubing

(1) Cut the tubing perpendicularly, being careful not to damage the outside surface. Use an SMC tubing cutter "TK-1", "TK-2" or "TK-3". Do not cut the tube with pliers, nippers, scissors, etc., otherwise, the tube will be deformed and trouble may result.

(2) The outside diameter of the polyurethane tubing swells when internal pressure is applied to it. Therefore, it may be possible that the tubing cannot be re-inserted into the one-touch fitting. Check the tubing outside diameter, and when the accuracy of the outside diameter is +0.07 mm or larger for $\varnothing 2$, +0.15 mm or larger for other sizes, insert into the one-touch fitting again, without cutting the tubing to use it. When the tubing is re-inserted into the one-touch fitting, confirm that the tubing goes through the release button smoothly.

(3) Grasp the tube, slowly push it into the one-touch fittings until it comes to a stop.

(4) Pull the tubing back gently to make sure it has a positive seal. Insufficient installation may cause air to leak or the tube to release.

2) Removing of tubing

(1) Push flange evenly and push the release button sufficiently.

(2) Pull out the tube while keeping the release button depressed. If the release button is not held down sufficiently, the tube cannot be withdrawn.

(3) To reuse the tubing, remove the previously lodged portion of the tube. If the lodged portion is left on without being removed, it may result in air leakage and removal of the tube difficult.

2. Connecting products with metal rods

After connecting the products with metal rods (Series KC, etc.) to the one-touch fittings, do not use tubes, resin plugs or reducers, etc. These may come off the fittings.

3. When mounting tubing, resin plugs, metal rods, etc., do not press the release button before mounting.

Also, do not press the release button before mounting. This may result in detachment.

4. When using a tubing other than from SMC, be careful of the tolerance of the tubing O.D. and tubing material.

- 1) Nylon tubing $\leq \pm 0.1$ mm
- 2) Soft nylon tubing $\leq \pm 0.1$ mm
- 3) Polyurethane tubing $\leq +0.15$ mm,
 ≤ -0.2 mm

When the tolerance of the tubing O.D. is insufficient, or the tubing I.D. is different from SMC dimensions, do not use the tube, because the following problems may occur: difficulty in connecting the tubing, leakage, disconnection of the tubing, or fitting damage.

Recommended Piping Conditions

1. When connecting piping to the one-touch fitting, use pipe length with sufficient margin, in accordance with the piping conditions shown in Figure 1.

Also, when using a tying band, etc., to bind the piping together, make sure that external force does not come to bear on the fitting. (see Figure 2)

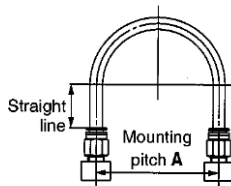

Figure 1 Recommended piping

Unit: mm

tubing size	Mounting pitch A			Straight-line Pipe length
	Nylon tube	Soft nylon tube	Polyurethane tube	
$\phi 3.2$, $\phi 1/8''$	44 or more	29 or more	25 or more	16 or more
$\phi 4$, $\phi 5/32''$	56 or more	30 or more	26 or more	20 or more
$\phi 3/16''$	67 or more	38 or more	38 or more	24 or more
$\phi 6$	84 or more	39 or more	39 or more	30 or more
$\phi 1/4''$	89 or more	56 or more	57 or more	32 or more
$\phi 8$, $5/16''$	112 or more	58 or more	52 or more	40 or more
$\phi 10$	140 or more	70 or more	69 or more	50 or more
$\phi 3/8''$	134 or more	76 or more	69 or more	48 or more
$\phi 12$	168 or more	82 or more	88 or more	60 or more
$\phi 1/2''$	178 or more	118 or more	93 or more	64 or more
$\phi 16$	224 or more	144 or more	114 or more	80 or more

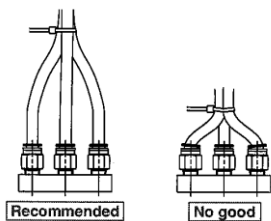

Figure 2 When using a tying band to bind the piping together

3. Application

This equipment is for a use to control the speed of the actuator.

4. Specifications

WORKING FLUID	A I R
Proof pressure	1. 5 MPa
Max. operating pressure	1 MPa
Min. operating pressure	0. 1 MPa
Ambient and fluid temperature	-5 to 60°C (NO FREEZING)
Tube material ⁽¹⁾	Nylon,Soft nylon,Polyurethane

Note 1) Use caution regarding the max.operating pressure when soft nylon or polyurethane tubing is used.

Note 2) Brass parts are all electroless nickel plated, provided as standard.

5. Troubleshooting

Trouble	Possible causes	Countermeasures
Speed(flow) cannot be adjust.	The product is installed in The opposite direction.	Check if the JIS symbol is suitable for the operating conditions.
	Dust inside.	Fully open the needle and apply air blow flom the free flow side. If the problem is not solved even after air blow, install an air filter to the piping, and replace the product with a new one.
Air leaks from the one-touch fitting. Or the tubing disconnects.	Tubing has been cut using pliers or nipper.	Use a tube cutter.
	The tolerance of the outside diameter of the tubing is outside of the specification.	If tubings made by manufacturers other than SMC are Used, check the accuracy of the tubings outside diameter. Nylon tube within ±0.1mm Soft nylon tube within ±0.1mm Polyurethane tube within +0.15mm within -0.2mm

6. Construction

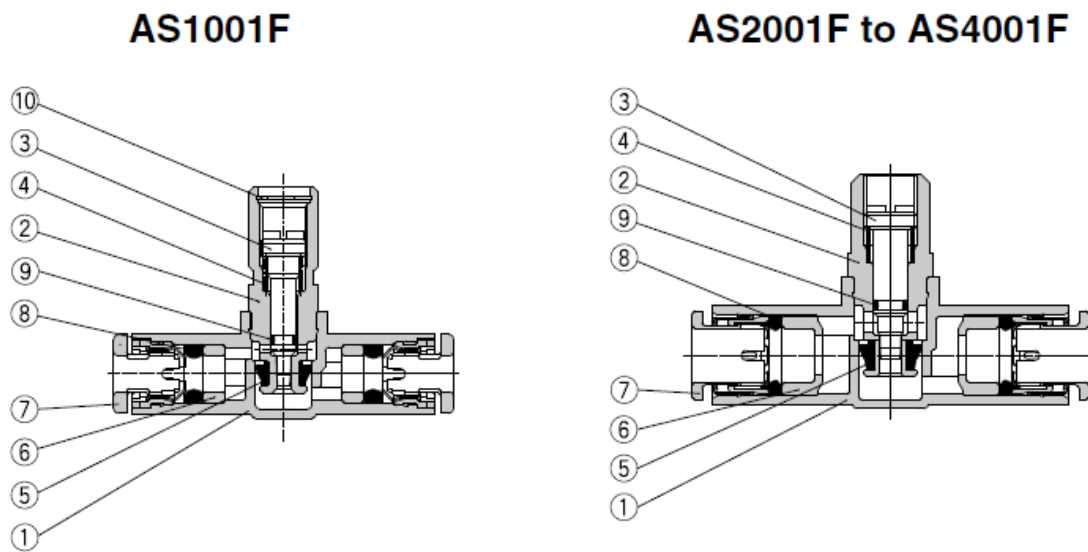

Component Parts

No.	Description	Material	Note
1	Body A	PBT	
2	Body B	Brass	Electroless nickel plated
3	Needle	Brass	Electroless nickel plated
4	Spring	Steel wire ⁽¹⁾	
5	U seal	HNBR	
6	Spacer	—	
7	Cassette	—	
8	Seal	NBR	
9	O-ring	NBR	
10	Retaining ring for hole type C	Tool steel	

Note 1) AS1001F type: Stainless steel

Revision history

SMC Corporation

Tel: + 81 3 5207 8249 Fax: +81 3 5298 5362
URL <https://www.smcworld.com>

Note: Specifications are subject to change without prior notice and any obligation on the part of the manufacturer.
© SMC Corporation All Rights Reserved