



# Operation Manual

PRODUCT NAME

*AIR FILTER*

MODEL / Series / Product Number

AF10-M5(C)(-2,6,R,Z)-A

AF20-(F,N)01 ~ (F,N)02(B,C)(-2,6,C,J,R,Z)-A

AF30-(F,N)02 ~ (F,N)03(B,C,D)(-2,6,8,J,R,W,Z)-A

AF40-(F,N)02 ~ (F,N)04(B,C,D)(-2,6,8,J,R,W,Z)-A

AF40-(F,N)06(B,C,D)(-2,6,8,J,R,W,Z)-A

AF50-(F,N)06 ~ (F,N)10(B)(-2,6,8,J,R,W,Z)-A

AF60-(F,N)10(B)(-2,6,8,J,R,W,Z)-A

**SMC Corporation**

# Contents

	Page
1. SAFETY INSTRUCTIONS	1-5
2. APPLICATION	6
3. SPECIFICATIONS	6
4. HOW TO ORDER	7
5. OPTIONAL BRACKET ASSEMBLY	8
6. TROUBLESHOOTING	9
7. CONSTRUCTION / PARTS LIST	10
8. SPECIFICATIONS OF BOWL ASSEMBLY	11-19
9. REPLACEMENT PROCEDURE	20-27
10. DISASSEMBLY DRAWING	28-29
11. DIMENSIONS	30



# Safety Instructions

These safety instructions are intended to prevent hazardous situations and/or equipment damage. These instructions indicate the level of potential hazard with the labels of “**Caution**,” “**Warning**” or “**Danger**.” They are all important notes for safety and must be followed in addition to International Standards (ISO/IEC)<sup>\*)</sup>, and other safety regulations.

\*) ISO 4414: Pneumatic fluid power - General rules and safety requirements for systems and their components  
ISO 4413: Hydraulic fluid power - General rules and safety requirements for systems and their components  
IEC 60204-1: Safety of machinery - Electrical equipment of machines - Part 1: General requirements  
ISO 10218-1: Robots and robotic devices - Safety requirements for industrial robots - Part 1: Robots  
etc.

	<b>Danger</b>	<b>Danger</b> indicates a hazard with a high level of risk which, if not avoided, will result in death or serious injury.
	<b>Warning</b>	<b>Warning</b> indicates a hazard with a medium level of risk which, if not avoided, could result in death or serious injury.
	<b>Caution</b>	<b>Caution</b> indicates a hazard with a low level of risk which, if not avoided, could result in minor or moderate injury.

## **Warning**

### **1. The compatibility of the product is the responsibility of the person who designs the equipment or decides its specifications.**

Since the product specified here is used under various operating conditions, its compatibility with specific equipment must be decided by the person who designs the equipment or decides its specifications based on necessary analysis and test results. The expected performance and safety assurance of the equipment will be the responsibility of the person who has determined its compatibility with the product. This person should also continuously review all specifications of the product referring to its latest catalog information, with a view to giving due consideration to any possibility of equipment failure when configuring the equipment.

### **2. Only personnel with appropriate training should operate machinery and equipment.**

The product specified here may become unsafe if handled incorrectly. The assembly, operation and maintenance of machines or equipment including our products must be performed by an operator who is appropriately trained and experienced.

### **3. Do not service or attempt to remove product and machinery/equipment until safety is confirmed.**

1. The inspection and maintenance of machinery/equipment should only be performed after measures to prevent falling or runaway of the driven objects have been confirmed.
2. When the product is to be removed, confirm that the safety measures as mentioned above are implemented and the power from any appropriate source is cut, and read and understand the specific product precautions of all relevant products carefully.
3. Before machinery/equipment is restarted, take measures to prevent unexpected operation and malfunction.

### **4. Our products cannot be used beyond their specifications. Our products are not developed, designed, and manufactured to be used under the following conditions or environments. Use under such conditions or environments is not covered.**

1. Conditions and environments outside of the given specifications, or use outdoors or in a place exposed to direct sunlight.
2. Use for nuclear power, railways, aviation, space equipment, ships, vehicles, military application, equipment affecting human life, body, and property, fuel equipment, entertainment equipment, emergency shut-off circuits, press clutches, brake circuits, safety equipment, etc., and use for applications that do not conform to standard specifications such as catalogs and operation manuals.
3. Use for interlock circuits, except for use with double interlock such as installing a mechanical protection function in case of failure. Please periodically inspect the product to confirm that the product is operating properly.



# Safety Instructions

## Caution

We develop, design, and manufacture our products to be used for automatic control equipment, and provide them for peaceful use in manufacturing industries.

**Use in non-manufacturing industries is not covered.**

Products we manufacture and sell cannot be used for the purpose of transactions or certification specified in the Measurement Act.

The new Measurement Act prohibits use of any unit other than SI units in Japan.

## Limited warranty and Disclaimer/Compliance Requirements

The product used is subject to the following “Limited warranty and Disclaimer” and “Compliance Requirements”. Read and accept them before using the product.

### Limited warranty and Disclaimer

1. The warranty period of the product is 1 year in service or 1.5 years after the product is delivered, whichever is first.\*2)  
Also, the product may have specified durability, running distance or replacement parts. Please consult your nearest sales branch.
2. For any failure or damage reported within the warranty period which is clearly our responsibility, a replacement product or necessary parts will be provided.  
This limited warranty applies only to our product independently, and not to any other damage incurred due to the failure of the product.
3. Prior to using SMC products, please read and understand the warranty terms and disclaimers noted in the specified catalog for the particular products.

**\*2) Vacuum pads are excluded from this 1 year warranty.**

A vacuum pad is a consumable part, so it is warranted for a year after it is delivered.

Also, even within the warranty period, the wear of a product due to the use of the vacuum pad or failure due to the deterioration of rubber material are not covered by the limited warranty

### Compliance Requirements

1. The use of SMC products with production equipment for the manufacture of weapons of mass destruction (WMD) or any other weapon is strictly prohibited.
2. The exports of SMC products or technology from one country to another are governed by the relevant security laws and regulations of the countries involved in the transaction. Prior to the shipment of a SMC product to another country, assure that all local rules governing that export are known and followed.

## Precautions for design

### **WARNING**

- ① If no leakage is allowed due to the environment, it cannot be used. Or operating fluid is not air, it cannot be used.
- ② External parts including the handle (Material: polyacetal) and bowl (Material: polycarbonate) are made of resin. Organic solvents including synthetic fluid, chemicals including acetone, alcohol, ethylene chloride, sulphuric acid, nitrate, hydrochloric acid, cutting oil, kerosene, gasoline, lock material of screw are harmful. Do not use the filter regulator where containing those.

Effects organic solvents and chemicals, and where these elements are likely to adhere to the equipment.

Chemical data for substances causing degradation (Reference)

Type	Chemical name	Application examples	Material	
			Polycarbonate	Nylon
Acid	Hydrochloric acid Sulphuric acid, Phosphoric acid Chromic acid	Acid washing liquid for metals	△	×
Alkaline	Sodium hydroxide (Caustic soda) Potash Calcium hydroxide (Slack lime) Ammonia water Carbonate of soda	Degreasing of metals Industrial salts Water-soluble cutting oil	×	○
Inorganic salts	Sodium sulphide Sulphate of potash Sulphate of soda	—	×	△
Chlorine solvents	Carbon tetrachloride Chloroform Ethylene chloride Methylene chloride	Cleaning liquid for metals Printing ink Dilution	×	△
Aromatic series	Benzene Toluene Paint thinner	Coatings Dry cleaning	×	△
Ketone	Acetone Methyl ethyl ketone Cyclohexane	Photographic film Dry cleaning Textile industries	×	×
Alcohol	Ethyl alcohol IPA Methyl alcohol	Antifreeze Adhesives	△	×
Oil	Gasoline Kerosene	—	×	○
Ester	Phthalic acid dim ethyl Phthalic acid diethyl Acetic acid	Synthetic oil Anti-rust additives	×	○
Ether	Methyl ether Ethyl ether	Brake oil additives	×	○
Amino	Methyl amino	Cutting oil Brake oil additives Rubber accelerator	×	×
Other	Thread -lock fluid Seawater Leak tester	—	×	△

○ : Essentially safe    △ : Some effects may occur    × : Effects will occur

When the above factors are present, or there is some doubt, use a metal case for safety.

- ③ Avoid the application where charge and discharge of pressure to bowl is switched frequently. This may damage the bowl. A metal bowl is recommended in these cases.
- ④ Protect from ultra violet ray and radiation heat by shield.

**⚠ CAUTION**

- ① AD17-A and AD27-A with auto drain may leak during exhaust of pressure. (This leakage is allowed in their constructions and not failure.) Be sure to connect piping for drain.

**Selection**

**⚠ WARNING**

- ① Grease used on the internal sliding parts and seals may flow to the outlet side.
- ② N.O. type auto drain should be used under the following requirements to avoid operating failure.  
Output of compressor: 0.75kW or more.  
Discharged flow rate: 100L/min (ANR) or more.  
If multiple auto drains are used, confirm used compressor has capacity over the result of multiplying the above capacity and the number of used auto drains.  
{For example, in case of two auto drain, the compressor need the capacity over 1.5kW [200L/min (ANR)].}  
Operating pressure: 0.1MPa or more at min..
- ③ N.C. type auto drain should be used under the following requirements to avoid operating failure.  
Operating pressure: 0.1MPa or more at min. for AD17-A and AD27-A, 0.15MPa or more at min. for AD37-A and AD47-A.

**Installation**

**⚠ CAUTION**

- ① Do not drop nor apply impact during transportation or installation. This can cause damage to the product.
- ② Do not install in areas of high humid or high temperature. It causes damage of the product and malfunction.
- ③ Connect the air filter ensuring the direction of "1" (IN) and "2" (OUT) for air direction or an arrow. Wrong connection may cause malfunction.
- ④ Install vertically so that outlet of drain would turned downward. Use with the outlet of drain turned horizontal or upward causes malfunction.
- ⑤ Make a space to provide easy access at the bottom when replacing element or draining bowl. The required space is shown on 「11. DIMENSIONS」 (P30).

**Piping**

**⚠ WARNING**

- ① Blow out or clean piping before piping to eliminate swarf, cutting oil, solid foreign material. Contamination of piping may cause damage or malfunction.
- ② When installing piping, avoid chips and sealing materials from piping screws entering the inside of equipment. Or malfunction may occur. When a sealant tape is used, leave 1 thread ridge exposed at the end of the threads.
- ③ Hold the female screw side and screw in piping with recommended tightening torque. Insufficient tightening torque lead to cause loose piping or sealing failure. Excessive torque may lead to cause screw breakage. Tightening without holding female screw side applies excessive force to the piping bracket which lead to cause breakage.

Recommended torque unit: N·m

Screw	M5	1/8	1/4	3/8	1/2	3/4	1
Torque	*1	7~9	12~14	22~24	28~30	28~30	36~38

\*1: First, tighten it by hand , then give it an additional 1/6 turn with a wrench.

- ④ Do not apply any torsional moment, or bending moment except the weight of the air filter itself. External piping needs to be supported separately. Hard piping like steel tube is susceptible to excessive moment load or vibration. Insert the flexible tube to cancel the influence.
- ⑤ Drain guide is not equipped with valve function. Be sure to connect piping for drain. No piping for drain allows the drain and compressed air to exhaust freely. Also, the piping should be performed with drain guide held by spanner to prevent breakage of bowl.

- ⑥ The piping for drain from auto drain should be connected under the following requirements to avoid operating failure.

AD17-A, AD27-A: I.D.  $\phi$ 2.5 ( $\phi$ 3/32") at min., Length 5m (200") at max.

AD37, 47(N)-A: I.D.  $\phi$ 4 ( $\phi$ 3/16") at min., Length 5m (200") at max.

AD38, 48(N)-A: I.D.  $\phi$ 6.5 ( $\phi$ 1/4") at min., Length 5m (200") at max.

### Air Source

#### **WARNING**

- ① Use clean air. Compressed air containing chemicals, organic solvent, synthetic oil or corrosive gas may lead to cause breakage of parts or malfunction.
- ② Air containing too much moisture may cause malfunction. Install the air drier or the aftercooler before the air filter.

### Maintenance

#### **WARNING**

- ① Maintenance and checks should be done by following the procedure in the operation manual. Incorrect handling of the product may cause breakage or malfunction of the equipment or device.
- ② Perform periodical check to find cracks, flaws or other deterioration on resin bowl. If any of them is seen, as malfunction is caused, replace with new bowl.
- ③ Check for dirt in resin bowl periodically. If any dirt is seen, replace with new bowl. And if removing off the dirt by washing instead of using a replacement, never use washing material other than neutral detergent. Otherwise, the bowl is damaged.
- ④ Open and close drain cock manually. Open and close too much may damage the drain cock.
- ⑤ Replace the element before 2 years passed since purchase or pressure drop from initial outlet pressure reaches 0.1MPa. Or the element is broken.
- ⑥ Drain the bowl by opening drain cock before the drain level in the bowl reaches baffle.

#### **CAUTION**

- ① Rotate the handle counterclockwise (O←direction) to exhaust the condensate of the C1SF-A, C2SF(-C)-A.  
Press the push button to exhaust the condensate of the C3SF(-W)-A and C4SF(-W)-A.
- ② Check the element periodically and replace it with a new one if necessary. If it is found that outlet pressure drops or the flow is restricted, check the condition of the element.
- ③ The manual exhaust for emergency case can be performed by counterclockwise rotation of the handle in AD17-A and AD27-A. (O←direction)  
For AD37-A, AD38-A, AD47-A and AD48-A, rotate the drain cock counterclockwise in that case.(O←direction)
- ④ For the N.C. type auto drain, when there is no pressure, condensate which does not operate the auto drain mechanism will remain in the bowl. It is recommended to release the residual condensate manually at the end of the working day.

## 2. APPLICATION

This product aims at eliminating excess moisture and solid foreign material in the air line.

## 3. SPECIFICATIONS

Model	AF10-A	AF20-A	AF30-A	AF40-A	AF40-06-A	AF50-A	AF60-A
Port size	M5	1/8, 1/4	1/4, 3/8	1/4, 3/8, 1/2	3/4	3/4, 1	1
Fluid	Air						
Ambient and fluid temperature	-5 ~ 60°C (Should be no freezing)						
Proof pressure	1.5 MPa						
Max. operating pressure	1.0 MPa						
Filtration	5 µm						
Drain capacity (cm <sup>3</sup> )	2.5	8	25	45			
Bowl material	Polycarbonate						
Bowl guard	—	Semi-standard (Steel plate)	Standard (Polycarbonate)				
Mass (kg)	0.06	0.08	0.18	0.36	0.41	0.87	1.00



# 4. HOW TO ORDER

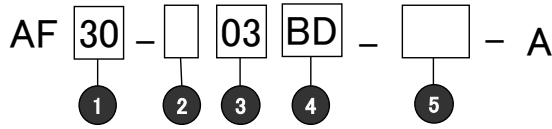

		Symbol	Description	1							
				Body size							
				10	20	30	40	50	60		
2	Thread type	Nil	Meter thread (M5)								
			Rc	●	-	-	-	-	-		
		N	NPT	-	●	●	●	●	●		
		F	G	-	●	●	●	●	●		
		+									
3	Port size	M5	M5	●	-	-	-	-	-		
		01	1/8	-	●	-	-	-	-		
		02	1/4	-	●	●	-	-	-		
		03	3/8	-	-	●	●	-	-		
		04	1/2	-	-	-	●	-	-		
		06	3/4	-	-	-	●	●	-		
		10	1	-	-	-	-	●	●		
		+									
4	Option	a	Mounting	Nil	Without mounting option						
			B	With bracket							
			+								
	b	Float type auto drain	Nil	Without auto drain							
			C	With float type auto drain (N.C.)							
			D	With float type auto drain (N.O.)							
		+									
5	Semi-standard	c	Bowl	Nil	Polycarbonate bowl						
				2	Metal bowl						
				6	Nylon bowl						
				8	Metal bowl with sight glass						
				C	With bowl guard (steel plate)						
				6C	With bowl guard (steel plate) · Nylon bowl						
				+							
		d	Drain port	Nil	With drain cock						
				J	Drain guide 1/8						
				W	Drain cock with barb fitting (For φ6xφ4 nylon tube)						
				+							
		e	Flow direction	Nil	Flow direction : Left to right						
				R	Flow direction : Right to left						
				+							
		f	Pressure unit	Nil	Name plate and caution plate for bowl in imperial units : MPa, °C						
				Z	Name plate and caution plate for bowl in imperial units : psi, °F						

※ Please refer to the catalog when you select the model.

## 5. OPTIONAL BRACKET ASSEMBLY

### 1) Bracket

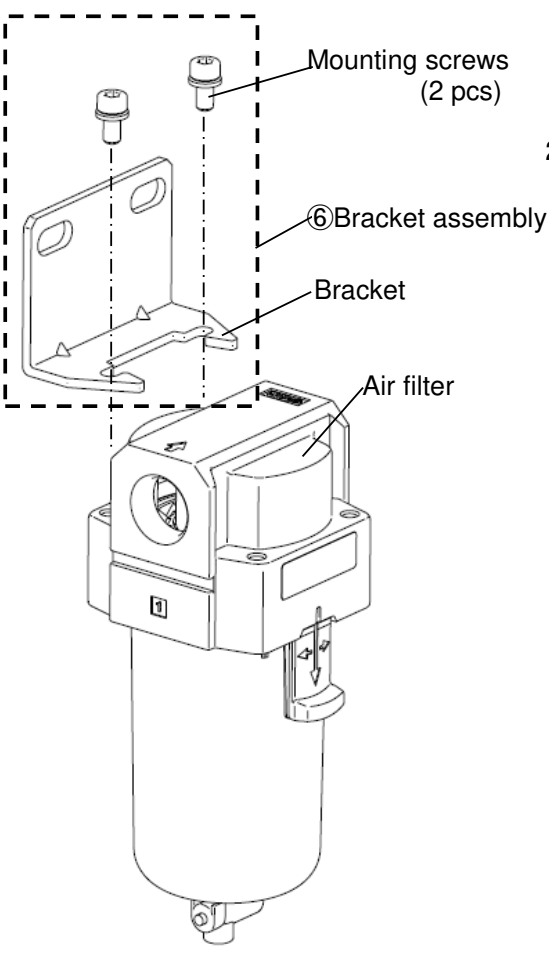

1) Installation of bracket  
Mount the bracket in the direction as shown in diagram.

2) Tightening of mounting screw  
Two mounting screws are tightened by cross pointed driver or hexagon spanner for holding.  
Refer to the table below for correct tool and the tightening torque required.

Air filter	Tools	Tightening torque
AF20-A	Cross pointed driver	$0.75 \pm 0.2 \text{ N} \cdot \text{m}$
AF30-A	Hexagon spanner: nominal 3	$0.75 \pm 0.2 \text{ N} \cdot \text{m}$
AF40-A	Hexagon spanner: nominal 4	$1.5 \pm 0.2 \text{ N} \cdot \text{m}$
AF50-A	Hexagon spanner: nominal 5	$2.6 \pm 0.3 \text{ N} \cdot \text{m}$
AF60-A		

## 6. TROUBLESHOOTING

Refer to 「7. CONSTRUCTION / PARTS LIST」 (P10), 「10. DISASSEMBLY DRAWING」 (P28 to P29).

TROUBLE		POSSIBLE CAUSE	REMEDY
DEMARCATON	PHENOMENON		
Flow rate	Large air resistance reduces flow rate.	1. Clog of the element.	1. Replace the element.
Air leaks	Air leaks between the bowl and the body.	1. Breakage of bowl packing.	1. Replace the bowl packing. Grease up before assembling.
	Air leaks from the bowl.	1. Breakage of bowl.	1. Replace the bowl assembly or with metal bowl.
	Air leaks from the drain cock.	1. The foreign matter caught in the valve of the drain cock. 2. Breakage of the seating part of the drain cock.	1. Open the drain cock for a few seconds for blowing. 2. Replace the bowl assembly.
Operational	No drainage when the drain cock is opened.	1. Blockage of outlet of the drain cock due to solid foreign matter etc.	1. Replace the bowl assembly.
	Too much drain comes from the piping of outlet side.	1. Drain level reaches the baffle plate.	1. Open the drain cock for draining and replace the element.

Note) Grease pack for maintenance "GR-F-###" is recommended for use. (See table 1, table 2)

Table 1. Coating amount per unit

Model	Mass( g )
AF20-A	0.1
AF30-A	0.15
AF40-A	0.2
AF50-A	0.25
AF60-A	0.25

Table 2. Grease pack No.

No.	Mass( g )
GR-F-005	5
GR-F-050	50
GR-F-100	100
GR-F-200	200
GR-F-500	500

## 7. CONSTRUCTION / PARTS LIST

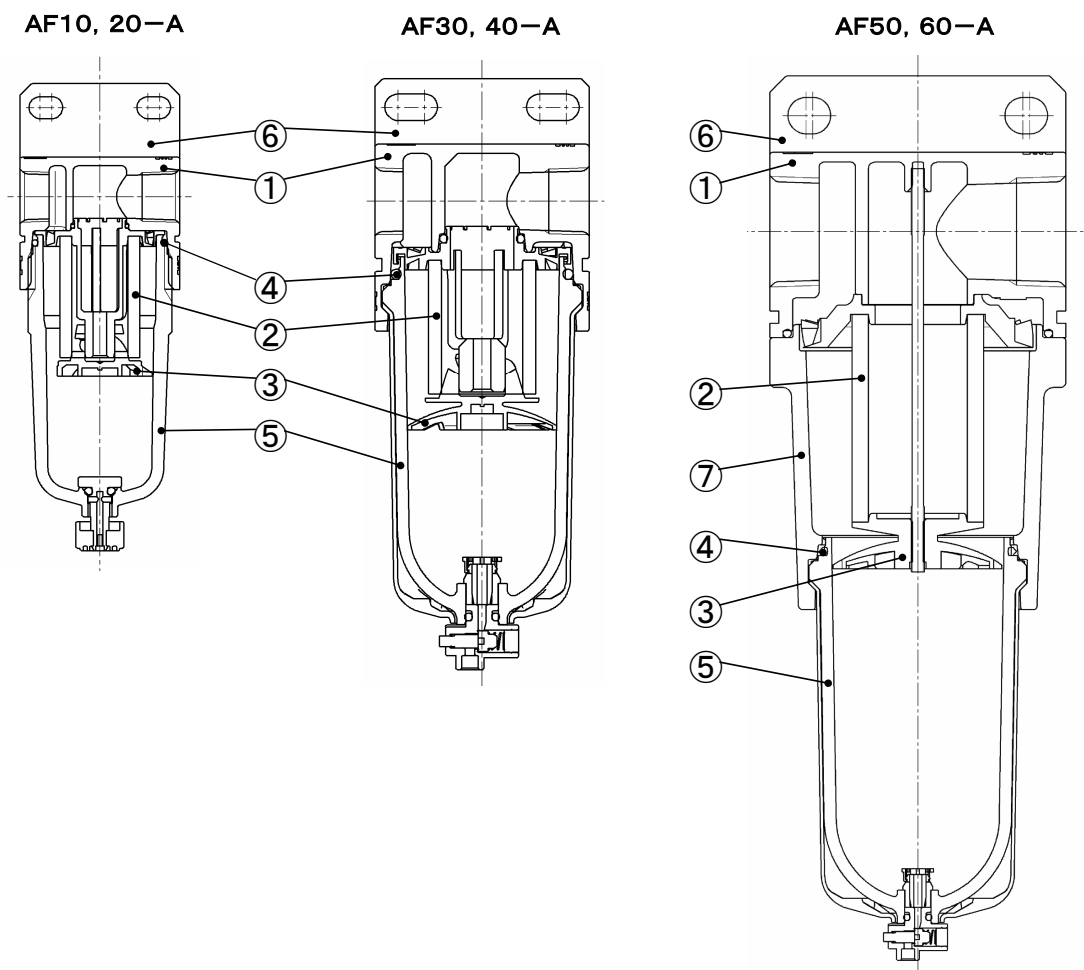

### Component Parts

No.	Description	Material	Applicable model	Note
①	Body	Zinc die cast	AF10-A	White
		Aluminium die cast	AF20-A~AF40-06-A	White
⑦	Housing	Aluminium die cast	AF50-A, AF60-A	White

### Option / Replacement Parts

No.	Description	Material	Part No.						
			AF10-A	AF20-A	AF30-A	AF40-A	AF40-06-A	AF50-A	AF60-A
②	Element	Polyolefin	AF10P-060S	AF20P-060S	AF30P-060S	AF40P-060S	AF40P-060S	AF50P-060S	AF60P-060S
③	Baffle	PBT	<sup>Note1)</sup> AF10P-040S	AF22P-040S	AF32P-040S	AF42P-040S	AF42P-040S	AF50P-040S	AF60P-040S
④	Bowl packing	NBR	C1SFP-260S	C2SFP-260S	C32FP-260S	C42FP-260S			
⑤	Bowl assembly	Polycarbonate	Refer to "8. SPECIFICATIONS OF BOWL ASSEMBLY" (P11 to P19).						
	Auto drain (N.C.)	Polycarbonate							
	Auto drain (N.O.)	Polycarbonate							
⑥	<sup>Note2)</sup> Bracket assembly	Steel plate	-	AF22P-050AS	AF32P-050AS	AF42P-050AS	AF42P-070AS	AF52P-050AS	

Note 1) For AF10 baffle material : POM (AF10P-040S only).

Note 2) Bracket with mounting screws.(2pcs)

Note 3) The number in the table is corresponding to the number in structural drawing (above-mentioned figure) and "8. SPECIFICATIONS OF BOWL ASSEMBLY" (P11 to P19), "10. DISASSEMBLY DRAWING" (P28 to P29).

## 8. SPECIFICATIONS OF BOWL ASSEMBLY

### 1) Bowl assembly / Auto drain for AF10-A

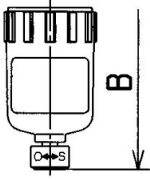
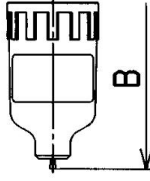
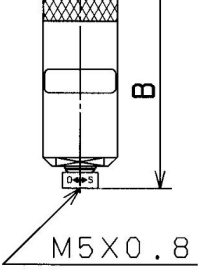
Option	—	6	Note 2) C
Semi-standard	—	6	6
External appearance drawing and part no.	Semi-standard 「—」 (Standard) ⑤Part no. C1SF(-Z)-A		Semi-standard 「—」 (Standard) ⑤Part no. AD17(-Z)-A
	Semi-standard 「6」 ⑤Part no. C1SF-6(Z)-A		Semi-standard 「6」 ⑤Part no. AD17-6(Z)-A
Option	—	2	Note 2) C
Semi-standard	—	2	2
External appearance drawing and part no.	⑤Part no. C1SF-2(Z)-A		⑤Part no. AD17-2(Z)-A
			

Note 1) B in the table shows full dimensions of the product. Refer to 「11. DIMENSIONS」 (P30).

Note 2) Min. operating pressure is 0.1MPa.

Note 3) "Z" of the part with no. ⑤ is semi-standard for indicated unit of pressure and temperature, which is psi and °F

Note 4) The symbol for option and semi-standard are described as 「4. HOW TO ORDER」(P7).

## 2) Bowl assembly / Auto drain for AF20-A

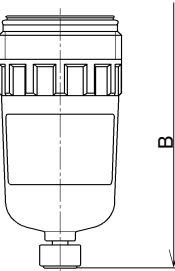
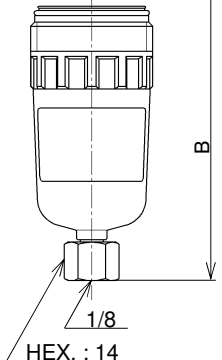
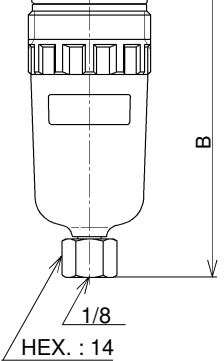
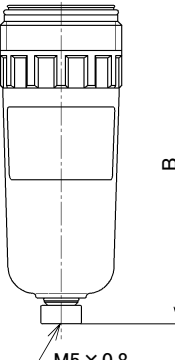
Option	-		-	
Semi-standard	-	6	C	6C
External appearance drawing and part no.	Semi-standard 「-」 (Standard)		Semi-standard 「C」	
	Port thread	⑤Part no.	Port thread	⑤Part no.
	Rc	C2SF-A	Rc	C2SF-C-A
	G	C2SF(-Z)-A	G	C2SF-C(Z)-A
Semi-standard 「6」			Semi-standard 「6C」	
Port thread	⑤Part no.		Port thread	⑤Part no.
Rc	C2SF-6-A		Rc	C2SF-6C-A
G	C2SF-6(Z)-A		G	C2SF-6C(Z)-A
NPT			NPT	
C2SF-6(Z)-A			C2SF-6C(Z)-A	
Option	-		-	
Semi-standard	J	6J	CJ	6CJ
External appearance drawing and part no.	Semi-standard 「J」		Semi-standard 「CJ」	
	Port thread	⑤Part no.	Port thread	⑤Part no.
	Rc	C2SF-J-A	Rc	C2SF-CJ-A
	G	C2SFF-J-A	G	C2SFF-CJ-A
NPT		C2SFN-J(Z)-A	NPT	
C2SFN-J(Z)-A			C2SFN-CJ(Z)-A	
Semi-standard 「6J」			Semi-standard 「6CJ」	
Port thread	⑤Part no.		Port thread	⑤Part no.
Rc	C2SF-6J-A		Rc	C2SF-6CJ-A
G	C2SFF-6J-A		G	C2SFF-6CJ-A
NPT		C2SFN-6J(Z)-A	NPT	
C2SFN-6J(Z)-A			C2SFN-6CJ(Z)-A	
Option	-		-	
Semi-standard	2	2J	2J	2J
External appearance drawing and part no.	Semi-standard 「2」		Semi-standard 「2J」	
	Port thread	⑤Part no.	Port thread	⑤Part no.
	Rc	C2SF-2-A	Rc	C2SF-2J-A
	G	C2SF-2(Z)-A	G	C2SFF-2J-A
NPT		C2SF-2(Z)-A	NPT	
C2SF-2(Z)-A			C2SFN-2J(Z)-A	
Semi-standard 「2J」			Semi-standard 「2J」	
Port thread	⑤Part no.		Port thread	⑤Part no.
Rc	C2SF-2J-A		Rc	C2SF-2J-A
G	C2SFF-2J-A		G	C2SFF-2J-A
NPT		C2SFN-2J(Z)-A	NPT	
C2SFN-2J(Z)-A			C2SFN-2J(Z)-A	
Option	Note 2) C		Note 2) C	
Semi-standard	-	6	C	6C
External appearance drawing and part no.	Semi-standard 「-」 (Standard)		Semi-standard 「C」	
	Port thread	⑤Part no.	Port thread	⑤Part no.
	Rc	AD27-A	Rc	AD27-C-A
	G	AD27(-Z)-A	G	AD27-C(Z)-A
NPT		AD27(-Z)-A	NPT	
AD27(-Z)-A			AD27-C(Z)-A	
Semi-standard 「6」			Semi-standard 「6C」	
Port thread	⑤Part no.		Port thread	⑤Part no.
Rc	AD27-6-A		Rc	AD27-6C-A
G	AD27-6(Z)-A		G	AD27-6C-A
NPT		AD27-6(Z)-A	NPT	
AD27-6(Z)-A			AD27-6C(Z)-A	

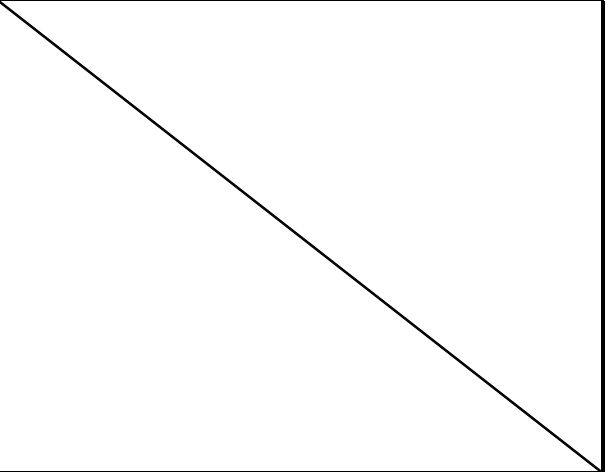
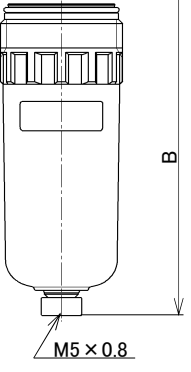
Option	Note 2) <b>C</b>		
Semi-standard	<b>2</b>		
External appearance drawing and part no.	Semi-standard 「2」		
	Port thread	⑤ Part no.	
	Rc	AD27-2-A	
G			
NPT	AD27-2(Z)-A		

Note 1) B in the table shows the distance from inlet piping centreline to drain port. Refer to "11. DIMENSIONS" (P30).

Note 2) Min. operating pressure is 0.1MPa.

Note 3) The part with no. ⑤ includes ④ Bowl packing. Refer to "10. DISASSEMBLY DRAWING" (P28 to P29).

Note 4) "Z" of the part with no. ⑤ is semi-standard for indicated unit of pressure and temperature, which is psi and °F.

Note 5) The symbol for option and semi-standard are described as "4. HOW TO ORDER" (P7).



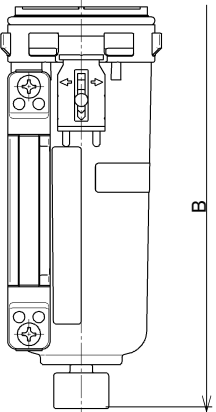
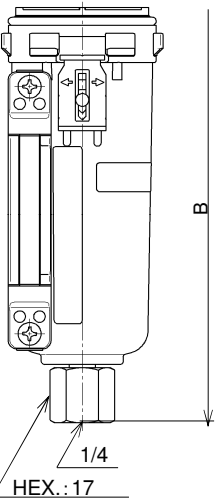
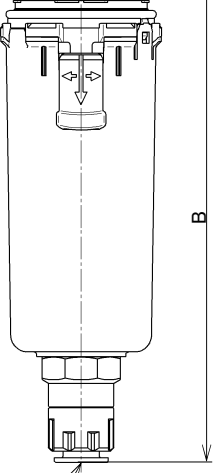
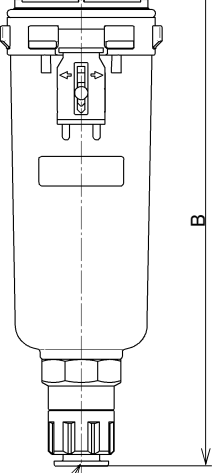
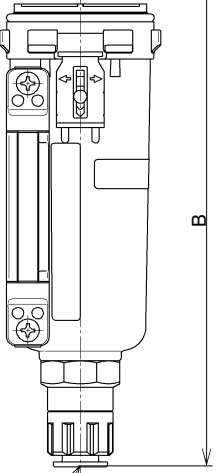

Option	—		—																									
Semi-standard	8		8J																									
External appearance drawing and part no.	<p>Semi-standard 「8」</p> <table border="1" data-bbox="352 248 639 394"> <tr> <td>Port thread</td> <td>⑤Part no.</td> </tr> <tr> <td>Rc</td> <td>C3LF-8-A</td> </tr> <tr> <td>G</td> <td>C3LF-8-A</td> </tr> <tr> <td>NPT</td> <td>C3LF-8(Z)-A</td> </tr> </table> 		Port thread	⑤Part no.	Rc	C3LF-8-A	G	C3LF-8-A	NPT	C3LF-8(Z)-A	<p>Semi-standard 「8J」</p> <table border="1" data-bbox="943 248 1230 394"> <tr> <td>Port thread</td> <td>⑤Part no.</td> </tr> <tr> <td>Rc</td> <td>C3LF-8J-A</td> </tr> <tr> <td>G</td> <td>C3LFF-8J-A</td> </tr> <tr> <td>NPT</td> <td>C3LFN-8J(Z)-A</td> </tr> </table> 		Port thread	⑤Part no.	Rc	C3LF-8J-A	G	C3LFF-8J-A	NPT	C3LFN-8J(Z)-A								
Port thread	⑤Part no.																											
Rc	C3LF-8-A																											
G	C3LF-8-A																											
NPT	C3LF-8(Z)-A																											
Port thread	⑤Part no.																											
Rc	C3LF-8J-A																											
G	C3LFF-8J-A																											
NPT	C3LFN-8J(Z)-A																											
Option	Note 2) C		Note 2) C																									
Semi-standard	—	6	2	2																								
External appearance drawing and part no.	<p>Semi-standard 「—」</p> <table border="1" data-bbox="352 931 639 1077"> <tr> <td>Port thread</td> <td>⑤Part no.</td> </tr> <tr> <td>Rc</td> <td>AD37-A</td> </tr> <tr> <td>G</td> <td>AD37-A</td> </tr> <tr> <td>NPT</td> <td>AD37N(Z)-A</td> </tr> </table> <p>Semi-standard 「6」</p> <table border="1" data-bbox="352 1133 639 1279"> <tr> <td>Port thread</td> <td>⑤Part no.</td> </tr> <tr> <td>Rc</td> <td>AD37-6-A</td> </tr> <tr> <td>G</td> <td>AD37-6-A</td> </tr> <tr> <td>NPT</td> <td>AD37N-6(Z)-A</td> </tr> </table>  <p>Applicable tube O.D. 10 (NPT: 3/8")</p>		Port thread	⑤Part no.	Rc	AD37-A	G	AD37-A	NPT	AD37N(Z)-A	Port thread	⑤Part no.	Rc	AD37-6-A	G	AD37-6-A	NPT	AD37N-6(Z)-A	<p>Semi-standard 「2」</p> <table border="1" data-bbox="943 931 1230 1077"> <tr> <td>Port thread</td> <td>⑤Part no.</td> </tr> <tr> <td>Rc</td> <td>AD37-2-A</td> </tr> <tr> <td>G</td> <td>AD37-2-A</td> </tr> <tr> <td>NPT</td> <td>AD37N-2(Z)-A</td> </tr> </table>  <p>Applicable tube O.D. 10 (NPT: 3/8")</p>		Port thread	⑤Part no.	Rc	AD37-2-A	G	AD37-2-A	NPT	AD37N-2(Z)-A
Port thread	⑤Part no.																											
Rc	AD37-A																											
G	AD37-A																											
NPT	AD37N(Z)-A																											
Port thread	⑤Part no.																											
Rc	AD37-6-A																											
G	AD37-6-A																											
NPT	AD37N-6(Z)-A																											
Port thread	⑤Part no.																											
Rc	AD37-2-A																											
G	AD37-2-A																											
NPT	AD37N-2(Z)-A																											
Option	Note 2) C																											
Semi-standard	8																											
External appearance drawing and part no.	<p>Semi-standard 「8」</p> <table border="1" data-bbox="352 1581 639 1727"> <tr> <td>Port thread</td> <td>⑤Part no.</td> </tr> <tr> <td>Rc</td> <td>AD37-8-A</td> </tr> <tr> <td>G</td> <td>AD37-8-A</td> </tr> <tr> <td>NPT</td> <td>AD37N-8(Z)-A</td> </tr> </table>  <p>Applicable tube O.D. 10 (NPT: 3/8")</p>		Port thread	⑤Part no.	Rc	AD37-8-A	G	AD37-8-A	NPT	AD37N-8(Z)-A																		
Port thread	⑤Part no.																											
Rc	AD37-8-A																											
G	AD37-8-A																											
NPT	AD37N-8(Z)-A																											

Option	Note 2) D		Note 2) D	
Semi-standard	—	6	2	
External appearance drawing and part no.	Semi-standard 「—」		Semi-standard 「2」	
	Port thread	⑤Part no.	Port thread	⑤Part no.
	Rc	AD38-A	Rc	AD38-2-A
	G		G	
	NPT	AD38N(-Z)-A	NPT	AD38N-2(Z)-A
	Semi-standard 「6」			
Port thread	⑤Part no.			
Rc	AD38-6-A			
G				
NPT	AD38N-6(Z)-A			
	Applicable tube O.D. 10 (NPT:3/8")		Applicable tube O.D. 10 (NPT:3/8")	
Option	Note 2) D			
Semi-standard	8		Metal bowl with sight glass Slide elevation	
External appearance drawing and part no.	Semi-standard 「8」			
	Port thread	⑤Part no.		
	Rc	AD38-8-A		
	G			
	NPT	AD38N-8(Z)-A		
	Applicable tube O.D. 10 (NPT:3/8")		31.5	

Note 1) B in the table shows the distance from inlet piping centreline to drain port. Refer to "11. DIMENSIONS" (P30).

Note 2) Min. operating pressure is 0.15MPa for N.C. type and 0.1MPa for N.O. type.

Note 3) The part with no. ⑤ includes ④ Bowl packing. Refer to "10. DISASSEMBLY DRAWING" (P28 to P29).

Note 4) "Z" of the part with no. ⑤ is semi-standard for indicated unit of pressure and temperature, which is psi and °F.

Note 5) The symbol for option and semi-standard are described as "4. HOW TO ORDER" (P7).

#### 4) Bowl assembly / Auto drain for AF40,50,60-A

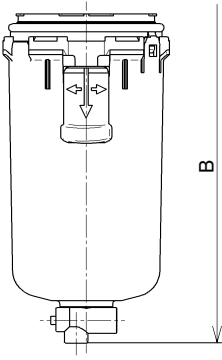
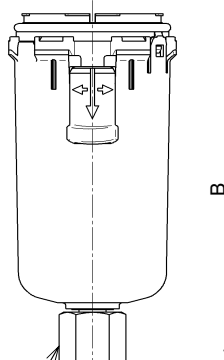
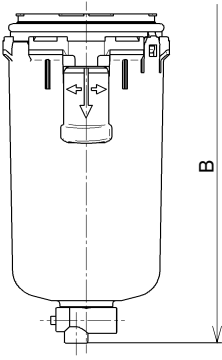
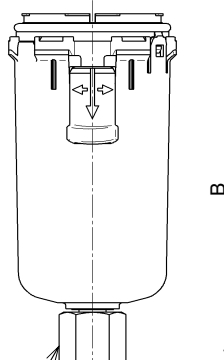
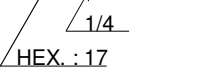
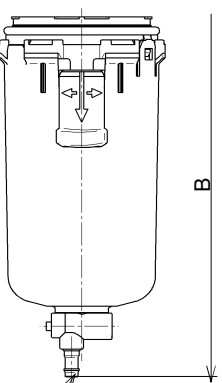
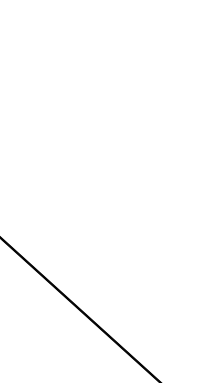
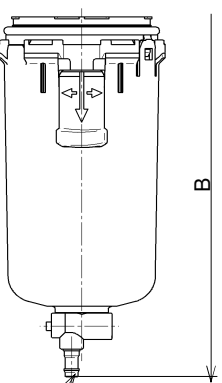
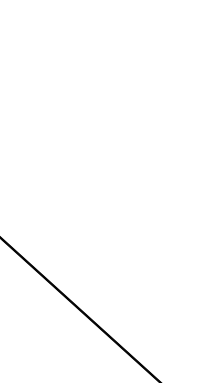
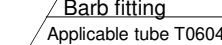
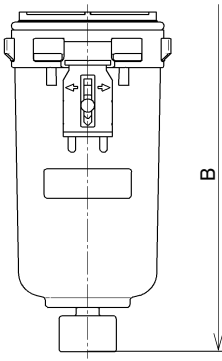
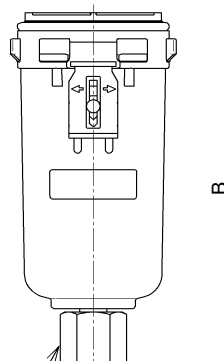
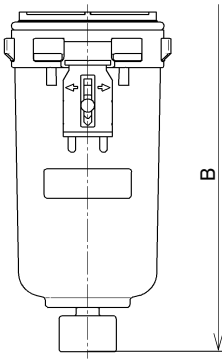
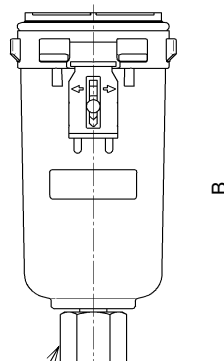
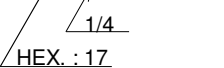
Option	-		-					
Semi-standard	-		6	J				
External appearance drawing and part no.	Semi-standard 「-」 (Standard)							
	Port thread	⑤Part no.			<table border="1"> <tr> <td>Rc</td> <td>C4SF-J-A</td> </tr> <tr> <td>G</td> <td>C4SFF-J-A</td> </tr> <tr> <td>NPT</td> <td>C4SFN-J(Z)-A</td> </tr> </table>	Rc	C4SF-J-A	G
Rc	C4SF-J-A							
G	C4SFF-J-A							
NPT	C4SFN-J(Z)-A							
External appearance drawing and part no.	Semi-standard 「6」							
	Port thread	⑤Part no.			<table border="1"> <tr> <td>Rc</td> <td>C4SF-6J-A</td> </tr> <tr> <td>G</td> <td>C4SFF-6J-A</td> </tr> <tr> <td>NPT</td> <td>C4SFN-6J(Z)-A</td> </tr> </table>	Rc	C4SF-6J-A	G
Rc	C4SF-6J-A							
G	C4SFF-6J-A							
NPT	C4SFN-6J(Z)-A							
								
Option	-		-					
Semi-standard	W		6W	J				
External appearance drawing and part no.	Semi-standard 「W」							
	Port thread	⑤Part no.			<table border="1"> <tr> <td>Rc</td> <td>C4SF-W-A</td> </tr> <tr> <td>G</td> <td>C4SF-W(Z)-A</td> </tr> </table>	Rc	C4SF-W-A	G
Rc	C4SF-W-A							
G	C4SF-W(Z)-A							
External appearance drawing and part no.	Semi-standard 「6W」							
	Port thread	⑤Part no.			<table border="1"> <tr> <td>Rc</td> <td>C4SF-6W-A</td> </tr> <tr> <td>G</td> <td>C4SF-6W(Z)-A</td> </tr> </table>	Rc	C4SF-6W-A	G
Rc	C4SF-6W-A							
G	C4SF-6W(Z)-A							
								
Option	-		-					
Semi-standard	2		2J	J				
External appearance drawing and part no.	Semi-standard 「2」							
	Port thread	⑤Part no.			<table border="1"> <tr> <td>Rc</td> <td>C4SF-2J-A</td> </tr> <tr> <td>G</td> <td>C4SFF-2J-A</td> </tr> <tr> <td>NPT</td> <td>C4SFN-2J(Z)-A</td> </tr> </table>	Rc	C4SF-2J-A	G
Rc	C4SF-2J-A							
G	C4SFF-2J-A							
NPT	C4SFN-2J(Z)-A							
External appearance drawing and part no.	Semi-standard 「2J」							
	Port thread	⑤Part no.			<table border="1"> <tr> <td>Rc</td> <td>C4SF-2J-A</td> </tr> <tr> <td>G</td> <td>C4SFF-2J-A</td> </tr> <tr> <td>NPT</td> <td>C4SFN-2J(Z)-A</td> </tr> </table>	Rc	C4SF-2J-A	G
Rc	C4SF-2J-A							
G	C4SFF-2J-A							
NPT	C4SFN-2J(Z)-A							
								

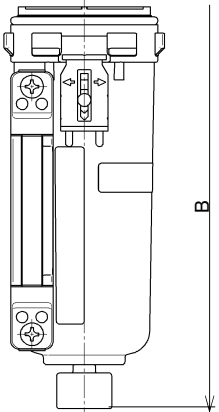
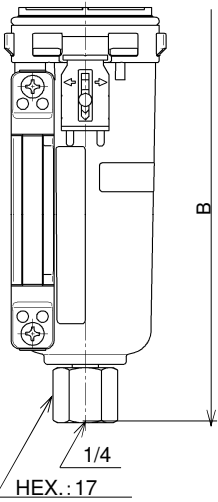
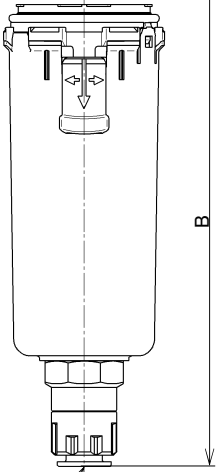
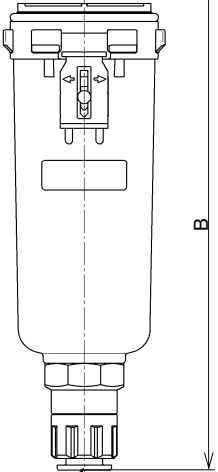
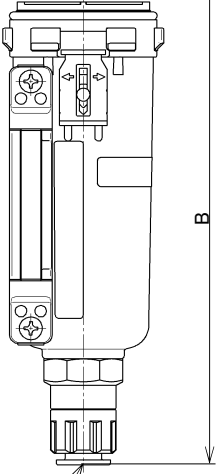
Option	—		—																									
Semi-standard	8		8J																									
External appearance drawing and part no.	<p>Semi-standard 「8」</p> <table border="1" data-bbox="352 248 639 394"> <tr> <td>Port thread</td> <td>⑤Part no.</td> </tr> <tr> <td>Rc</td> <td>C4LF-8-A</td> </tr> <tr> <td>G</td> <td>C4LF-8-A</td> </tr> <tr> <td>NPT</td> <td>C4LF-8(Z)-A</td> </tr> </table> 		Port thread	⑤Part no.	Rc	C4LF-8-A	G	C4LF-8-A	NPT	C4LF-8(Z)-A	<p>Semi-standard 「8J」</p> <table border="1" data-bbox="943 248 1230 394"> <tr> <td>Port thread</td> <td>⑤Part no.</td> </tr> <tr> <td>Rc</td> <td>C4LF-8J-A</td> </tr> <tr> <td>G</td> <td>C4LFF-8J-A</td> </tr> <tr> <td>NPT</td> <td>C4LFN-8J(Z)-A</td> </tr> </table> 		Port thread	⑤Part no.	Rc	C4LF-8J-A	G	C4LFF-8J-A	NPT	C4LFN-8J(Z)-A								
Port thread	⑤Part no.																											
Rc	C4LF-8-A																											
G	C4LF-8-A																											
NPT	C4LF-8(Z)-A																											
Port thread	⑤Part no.																											
Rc	C4LF-8J-A																											
G	C4LFF-8J-A																											
NPT	C4LFN-8J(Z)-A																											
Option	Note 2) C		Note 2) C																									
Semi-standard	—	6	2	2																								
External appearance drawing and part no.	<p>Semi-standard 「—」</p> <table border="1" data-bbox="352 927 639 1072"> <tr> <td>Port thread</td> <td>⑤Part no.</td> </tr> <tr> <td>Rc</td> <td>AD47-A</td> </tr> <tr> <td>G</td> <td>AD47-A</td> </tr> <tr> <td>NPT</td> <td>AD47N(Z)-A</td> </tr> </table> <p>Semi-standard 「6」</p> <table border="1" data-bbox="352 1128 639 1274"> <tr> <td>Port thread</td> <td>⑤Part no.</td> </tr> <tr> <td>Rc</td> <td>AD47-6-A</td> </tr> <tr> <td>G</td> <td>AD47-6-A</td> </tr> <tr> <td>NPT</td> <td>AD47N-6(Z)-A</td> </tr> </table>  <p>Applicable tube O.D. 10 (NPT: 3/8")</p>		Port thread	⑤Part no.	Rc	AD47-A	G	AD47-A	NPT	AD47N(Z)-A	Port thread	⑤Part no.	Rc	AD47-6-A	G	AD47-6-A	NPT	AD47N-6(Z)-A	<p>Semi-standard 「2」</p> <table border="1" data-bbox="943 927 1230 1072"> <tr> <td>Port thread</td> <td>⑤Part no.</td> </tr> <tr> <td>Rc</td> <td>AD47-2-A</td> </tr> <tr> <td>G</td> <td>AD47-2-A</td> </tr> <tr> <td>NPT</td> <td>AD47N-2(Z)-A</td> </tr> </table>  <p>Applicable tube O.D. 10 (NPT: 3/8")</p>		Port thread	⑤Part no.	Rc	AD47-2-A	G	AD47-2-A	NPT	AD47N-2(Z)-A
Port thread	⑤Part no.																											
Rc	AD47-A																											
G	AD47-A																											
NPT	AD47N(Z)-A																											
Port thread	⑤Part no.																											
Rc	AD47-6-A																											
G	AD47-6-A																											
NPT	AD47N-6(Z)-A																											
Port thread	⑤Part no.																											
Rc	AD47-2-A																											
G	AD47-2-A																											
NPT	AD47N-2(Z)-A																											
Option	Note 2) C																											
Semi-standard	8																											
External appearance drawing and part no.	<p>Semi-standard 「8」</p> <table border="1" data-bbox="352 1583 639 1729"> <tr> <td>Port thread</td> <td>⑤Part no.</td> </tr> <tr> <td>Rc</td> <td>AD47-8-A</td> </tr> <tr> <td>G</td> <td>AD47-8-A</td> </tr> <tr> <td>NPT</td> <td>AD47N-8(Z)-A</td> </tr> </table>  <p>Applicable tube O.D. 10 (NPT: 3/8")</p>		Port thread	⑤Part no.	Rc	AD47-8-A	G	AD47-8-A	NPT	AD47N-8(Z)-A																		
Port thread	⑤Part no.																											
Rc	AD47-8-A																											
G	AD47-8-A																											
NPT	AD47N-8(Z)-A																											

Option	Note 2) D		Note 2) D	
Semi-standard	—	6	2	
External appearance drawing and part no.	Semi-standard 「—」		Semi-standard 「2」	
	Port thread	⑤Part no.	Port thread	⑤Part no.
	Rc	AD48-A	Rc	AD48-2-A
	G		G	
	NPT	AD48N(-Z)-A	NPT	AD48N-2(Z)-A
	Semi-standard 「6」			
Port thread	⑤Part no.			
Rc	AD48-6-A			
G				
NPT	AD48N-6(Z)-A			
	Applicable tube O.D. 10 (NPT:3/8")		Applicable tube O.D. 10 (NPT:3/8")	
Option	Note 2) D			
Semi-standard	8		Metal bowl with sight glass Slide elevation	
External appearance drawing and part no.	Semi-standard 「8」			
	Port thread	⑤Part no.		
	Rc	AD48-8-A		
	G			
	NPT	AD48N-8(Z)-A		
	Applicable tube O.D. 10 (NPT:3/8")		38	

Note 1) B in the table shows the distance from inlet piping centreline to drain port. Refer to "11. DIMENSIONS" (P30).

Note 2) Min. operating pressure is 0.15MPa for N.C. type and 0.1MPa for N.O. type.

Note 3) The part with no. ⑤ includes ④ Bowl packing. Refer to "10. DISASSEMBLY DRAWING" (P28 to P29).

Note 4) "Z" of the part with no. ⑤ is semi-standard for indicated unit of pressure and temperature, which is psi and °F.

Note 5) The symbol for option and semi-standard are described as "4. HOW TO ORDER" (P7).

## 9. REPLACEMENT PROCEDURE

### WARNING

- Before replacement, ensure that the air filter is not pressurized.
- Replace referring to "10. DISASSEMBLY DRAWING" (P28 to P29).
- After replacement, ensure that specified function is satisfied and external leakage is not found before starting operation.

### 1) Bowl assembly / element

**【AF10—A】**

**<Disassembly>**

Step 1

Remove the bowl assembly. Hold the bowl assembly by hand and rotate counterclockwise to remove the bowl assembly. If the bowl assembly is tightened too much to be removed, use hook spanner until it can be loosened by hand.  
( Hook spanner Nominal : 25/28 )

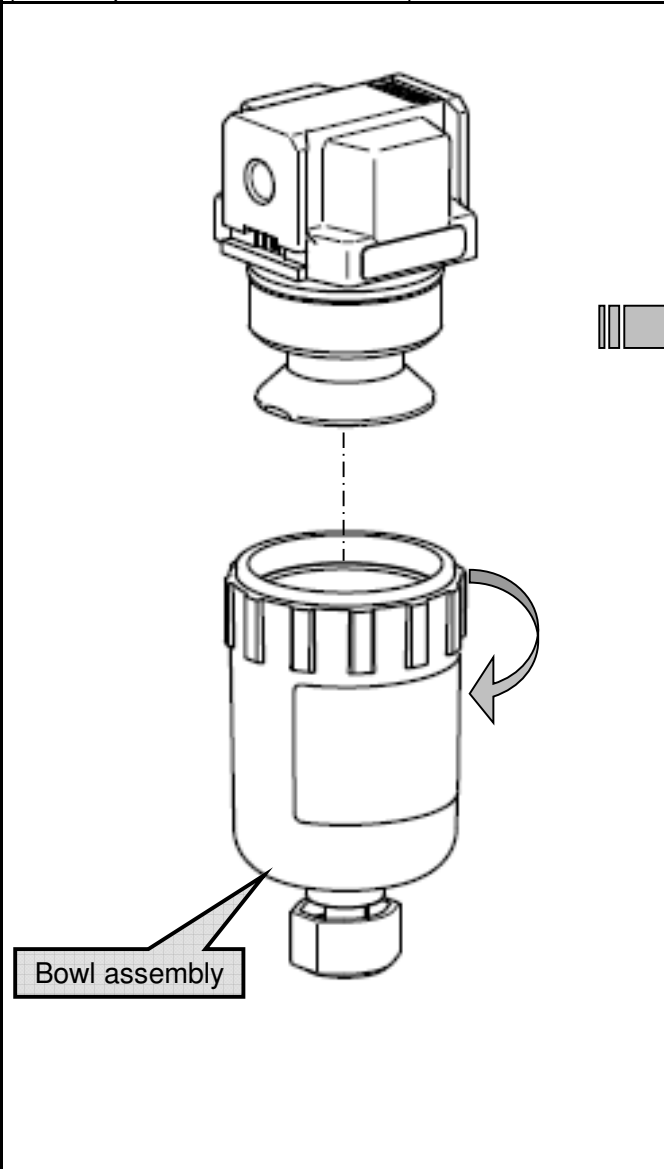

Step 1

Rotate the baffle by hand and counterclockwise to remove the baffle and element.

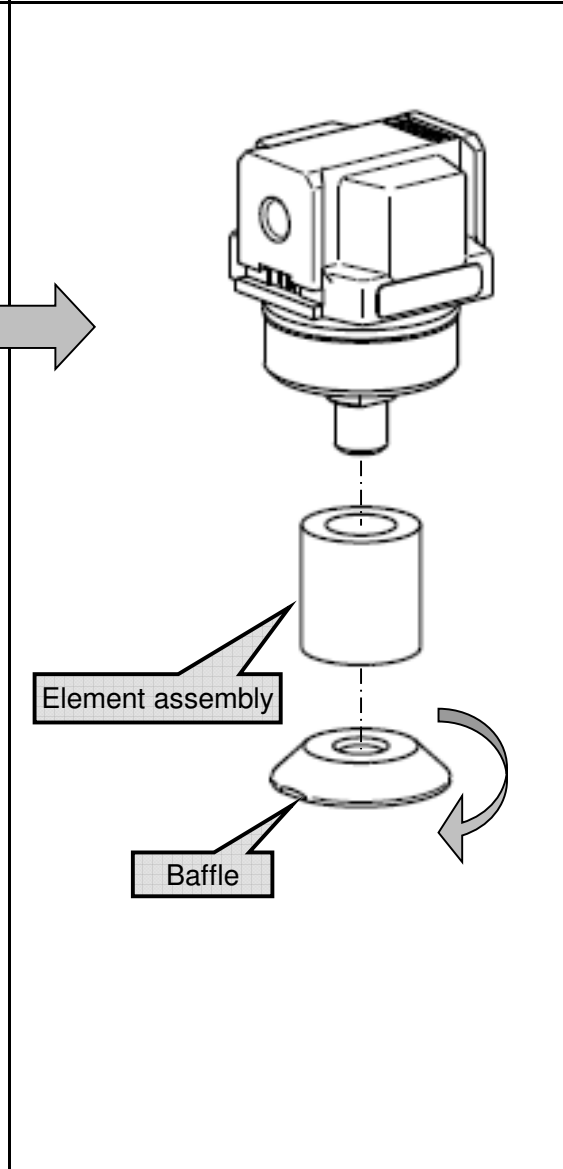

**[AF10-A]**

**<Assembly>**

**Step 1**

Mount the element to the element guide.  
Hold the baffle by hand to rotate it clockwise and mount the element.

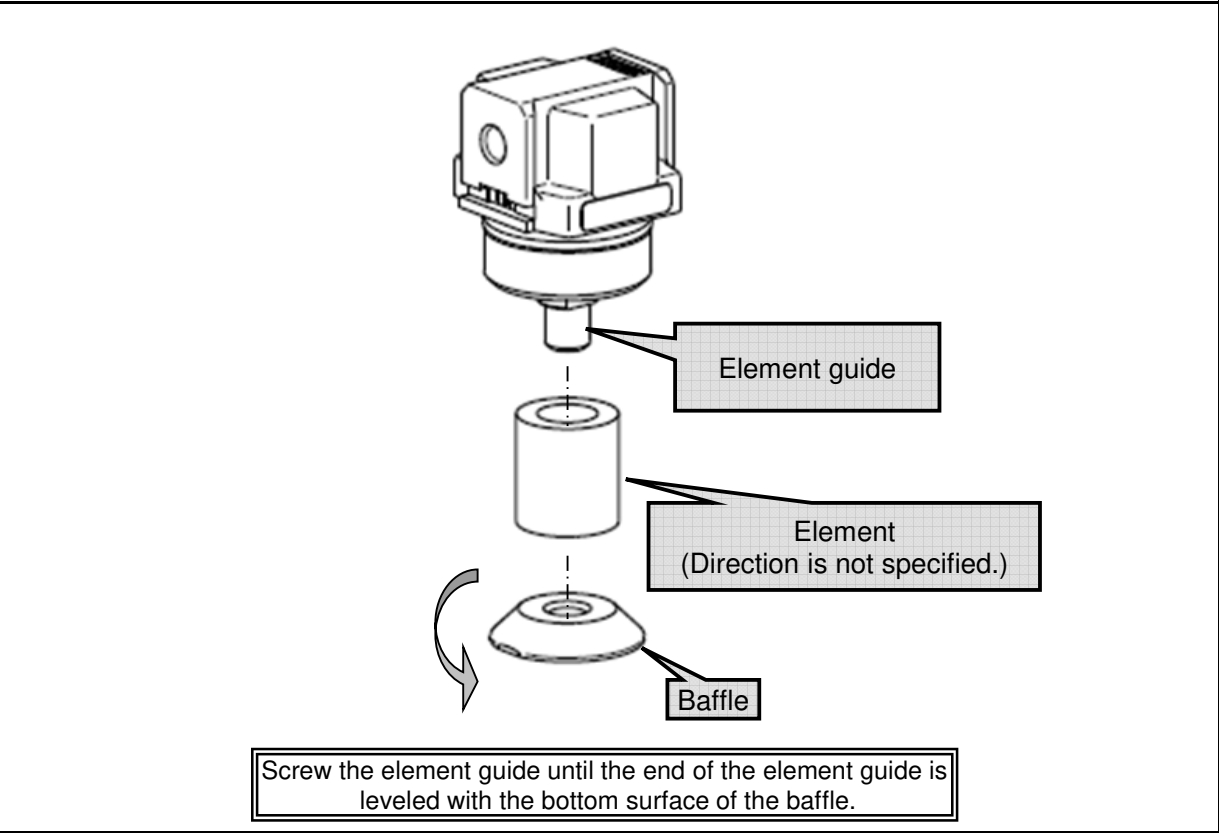

**Step 2**

Hold the baffle by hand to rotate it clockwise and mount the element.  
Tighten by hand is the followed tightening to torque level shown.

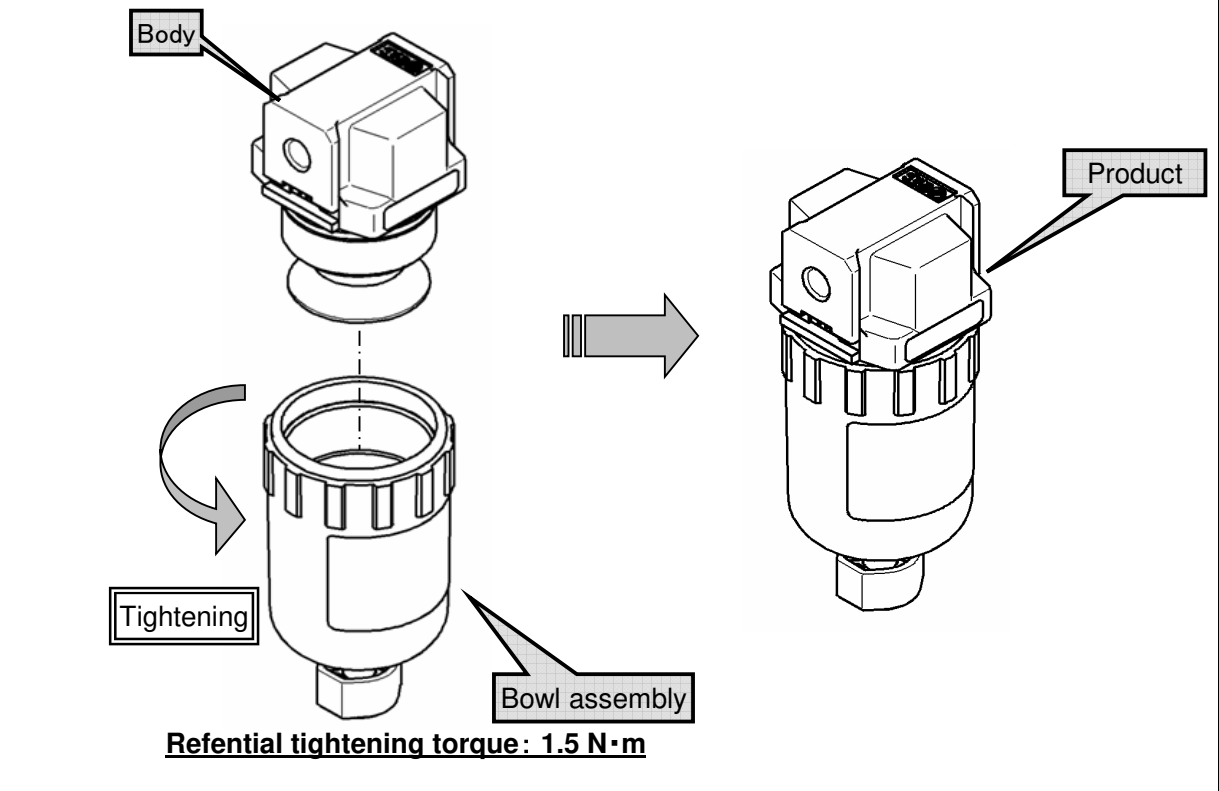

# [AF20-A]

## <Disassembly>

### Step 1

The bowl assembly is released counterclockwise, detaches it from the product. If the bowl assembly is tightened too much to be removed, use hook spanner until it can be loosened by hand.  
[SMC's special spanner P/N: 1129129 (Recommended)]

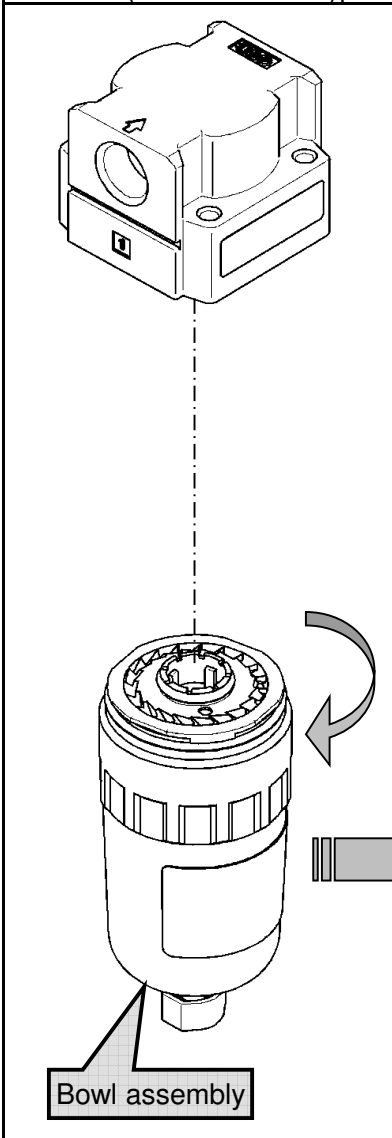

### Step 2

Detach the element assembly by grasping the outer edge between the 2 snap fits of the deflector and pulling up.

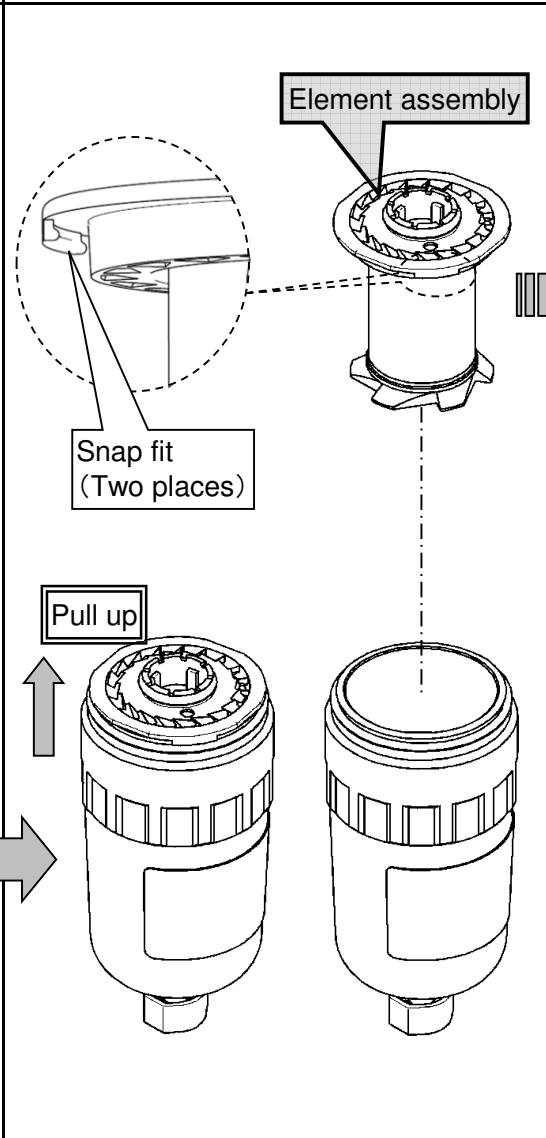

### Step 3

The baffle is rotated to the direction of the arrow and the element is detached.

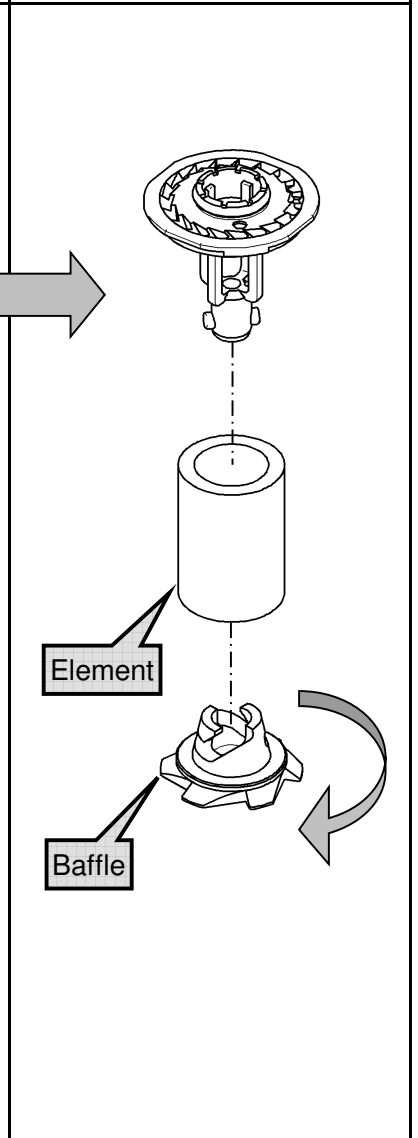



**[AF20—A]**

**<Assembly>**

Step 1

The element is attached to the deflector, and fixed into position in the direction shown.

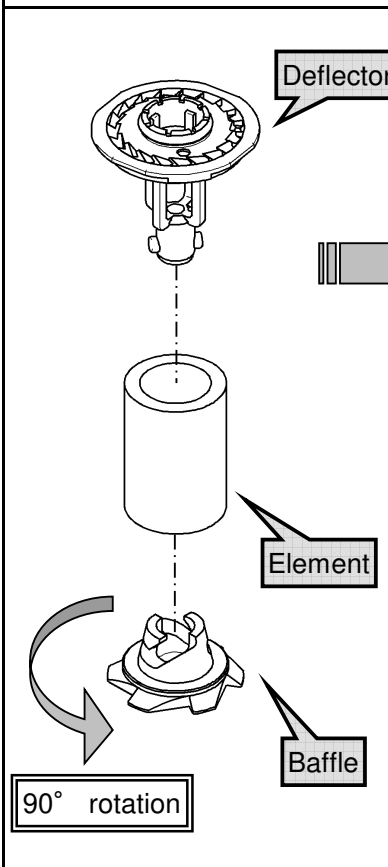

Step 2

When the element assembly is attached to the bowl assembly, the snap fit of the deflector is attached to the bowl assembly. (Until a 'pop' is heard)

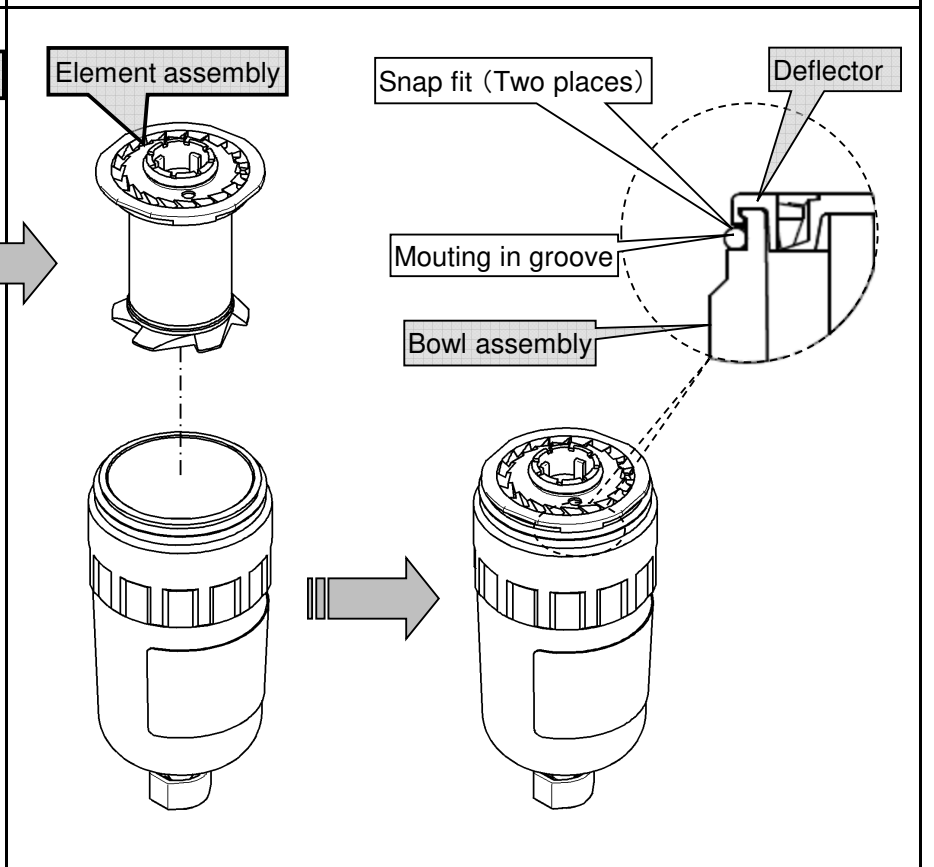

Step 3

The bowl assembly is rotated clockwise and secured to the product. Tighten by hand is the followed tightening to torque level shown.

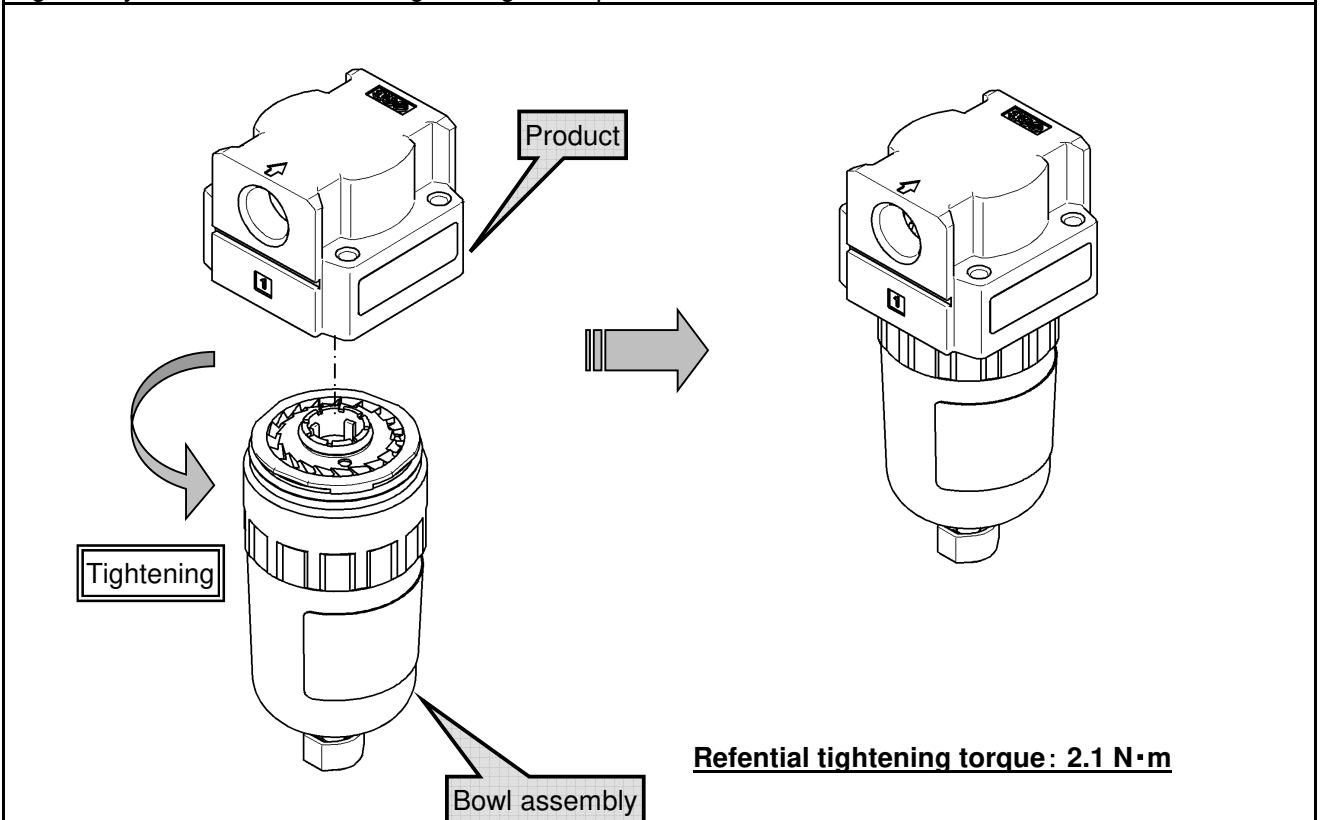

**【AF30, 40—A】**

**<Disassembly>**

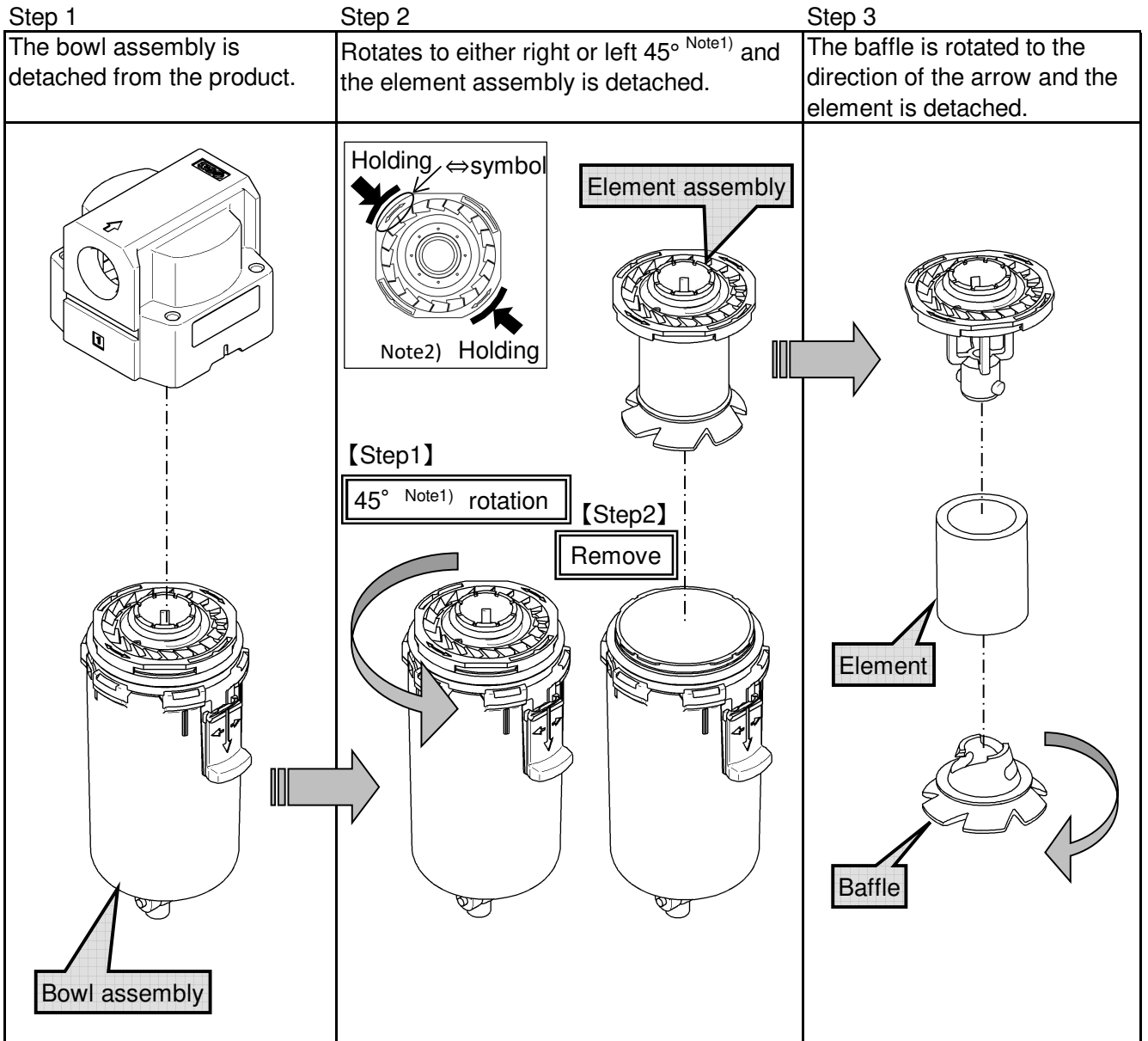

Note 1) Rotate 90 degrees to remove when -2 (Metal bowl), -8 (Metal bowl with level gauge).

Note 2) Rotate the element assembly holding the outer surface of the ⇄ symbol.

**[AF30, 40-A]**

**<Assembly>**

**Step 1**

The element is attached to the deflector, and fixed into position in the direction shown.

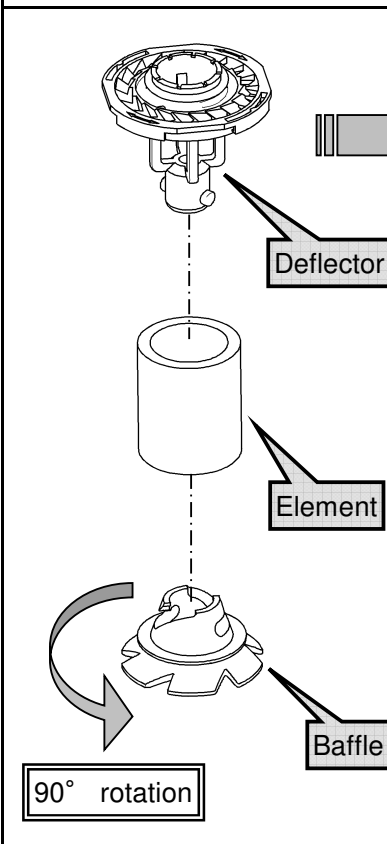

**Step 2**

To attach element assembly to the bowl assembly. Concave of the bowl assembly is combined with convex of the element assembly. Rotate to either right and left by 45°.

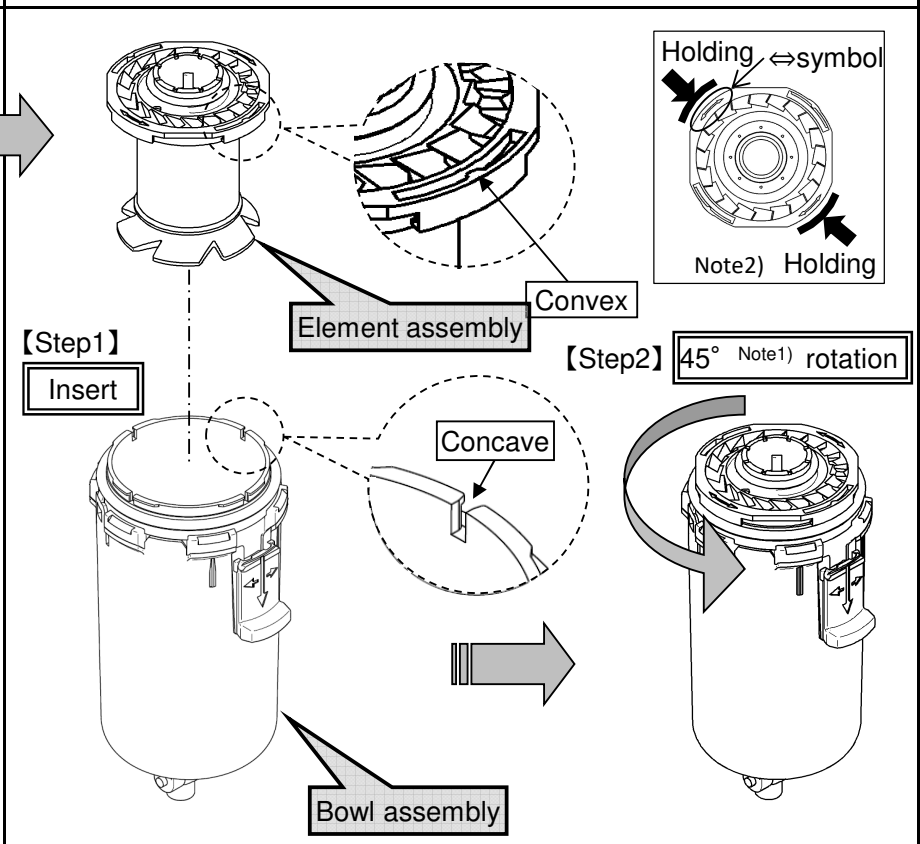

**Step 3**

The bowl assembly is rotated until the bowl assembly is attached to the product, and the lock button clicks into body when locked in position.

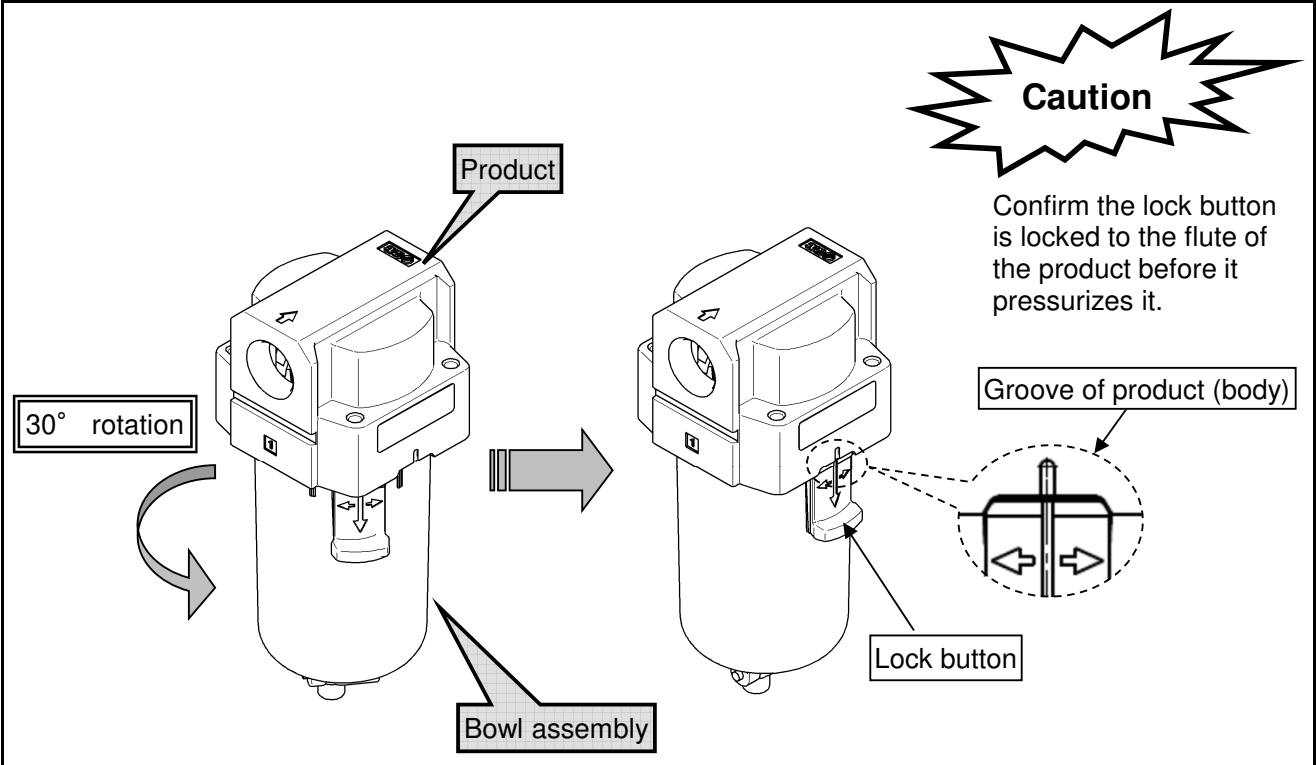

Note 1) Rotate 90 degrees to remove when -2 (Metal bowl), -8 (Metal bowl with level gauge).

Note 2) Rotate the element assembly holding the outer surface of the ⇄ symbol.

**【AF50, 60—A】**

**<Disassembly>**

Step 1

The bowl assembly is detached from the product.

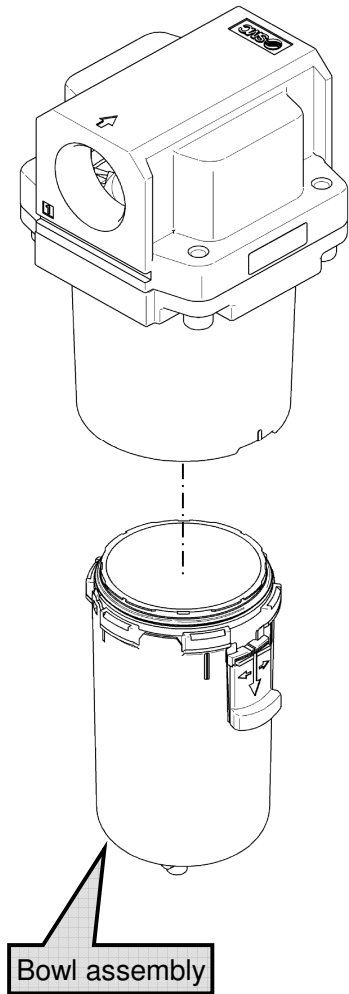

Step 2

The baffle is rotated to the direction of the arrow and the element is detached.

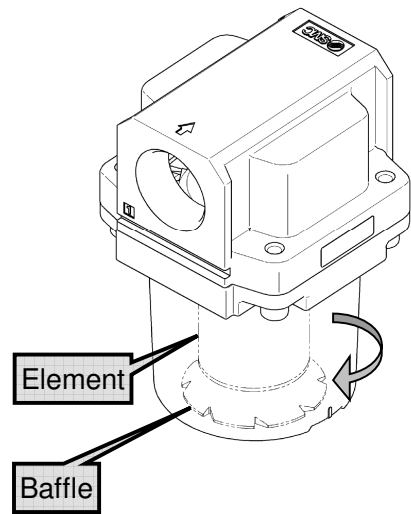

# 【AF50, 60—A】

## <Assembly>

### Step 1

Insert the element to the concave of the deflector.

Careful to the direction (convex to the element side) of mount and insert the baffle to the element.

Rotate it right with a hand till baffle will join element lightly. After that, rotate it right about 1/2 to tight it up.

Tighten by hand is the followed tightening to torque level shown.

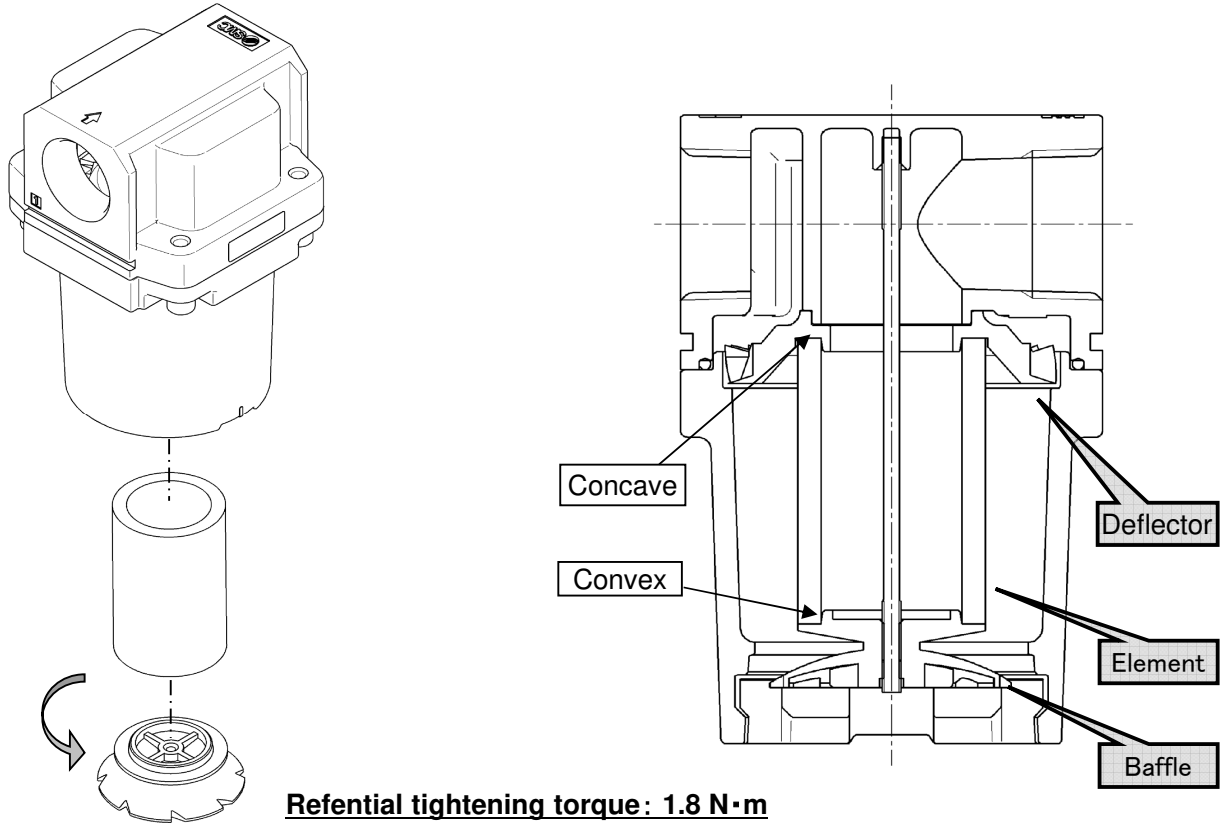

### Step 2

The bowl assembly is rotated until the bowl assembly is attached to the housing, and the lock button clicks into body when locked in position.

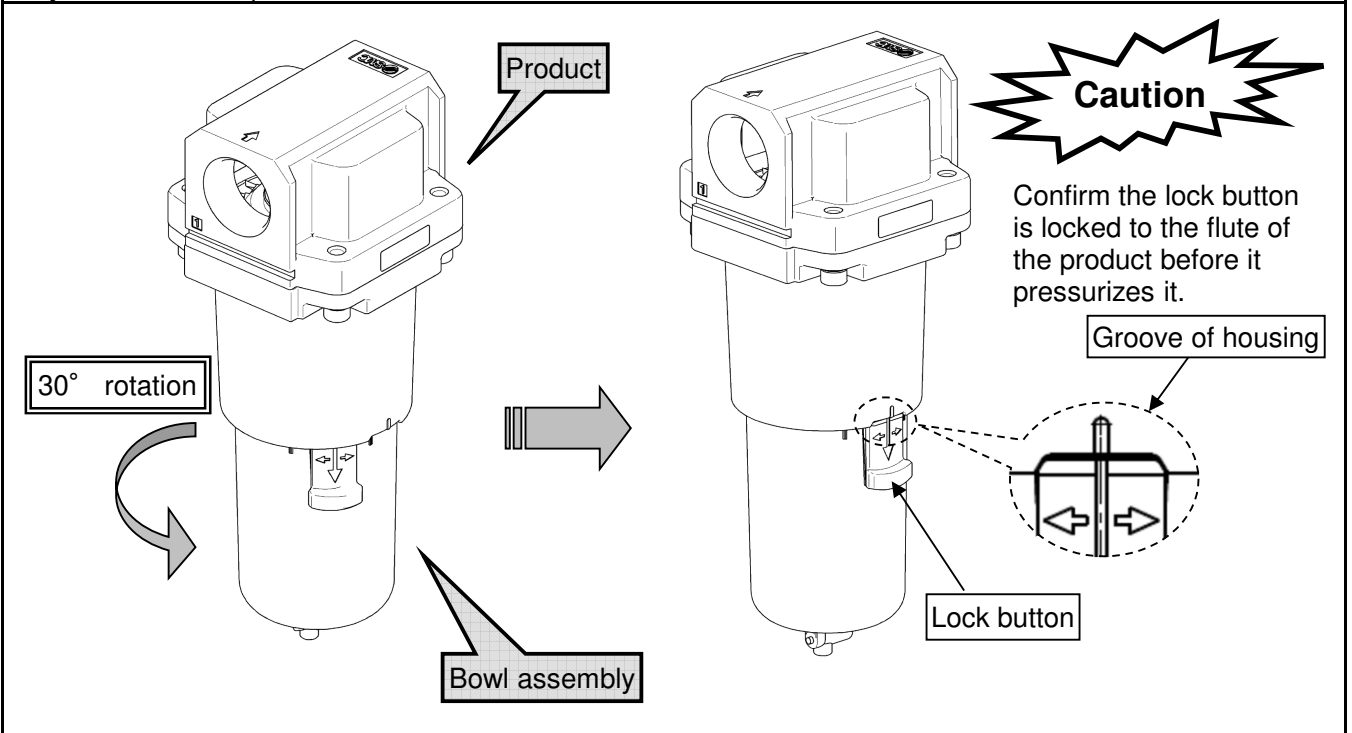

# 10. DISASSEMBLY DRAWING

## 1) AF10-A

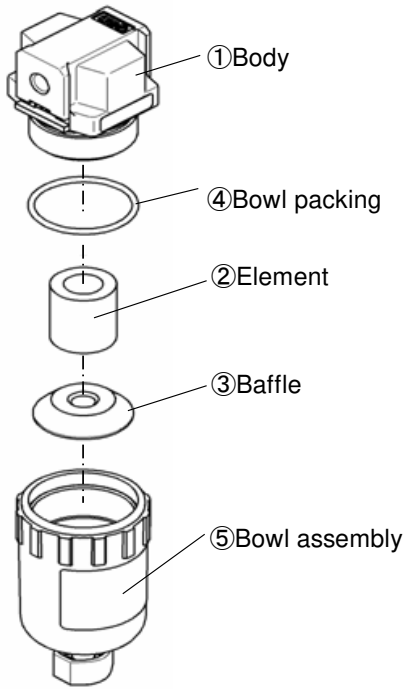

## 2) AF20-A

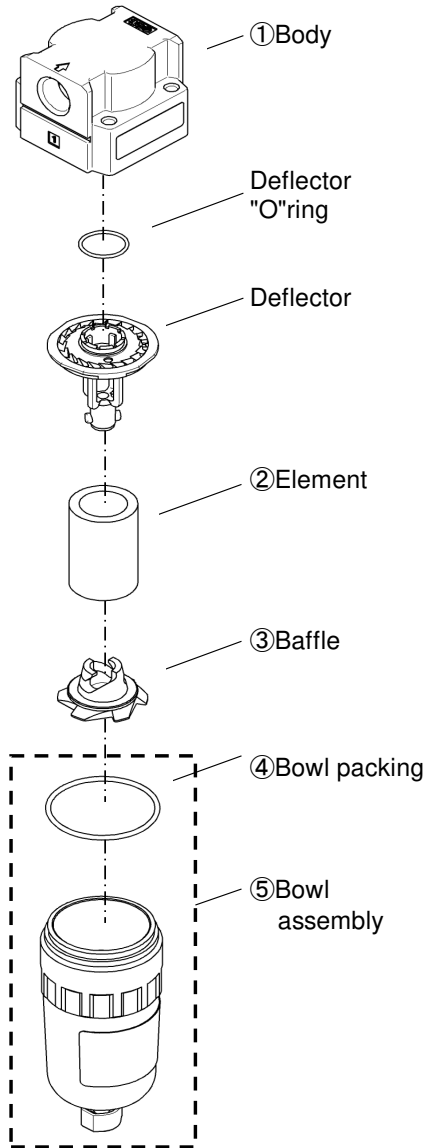

## 3) AF30,40-A

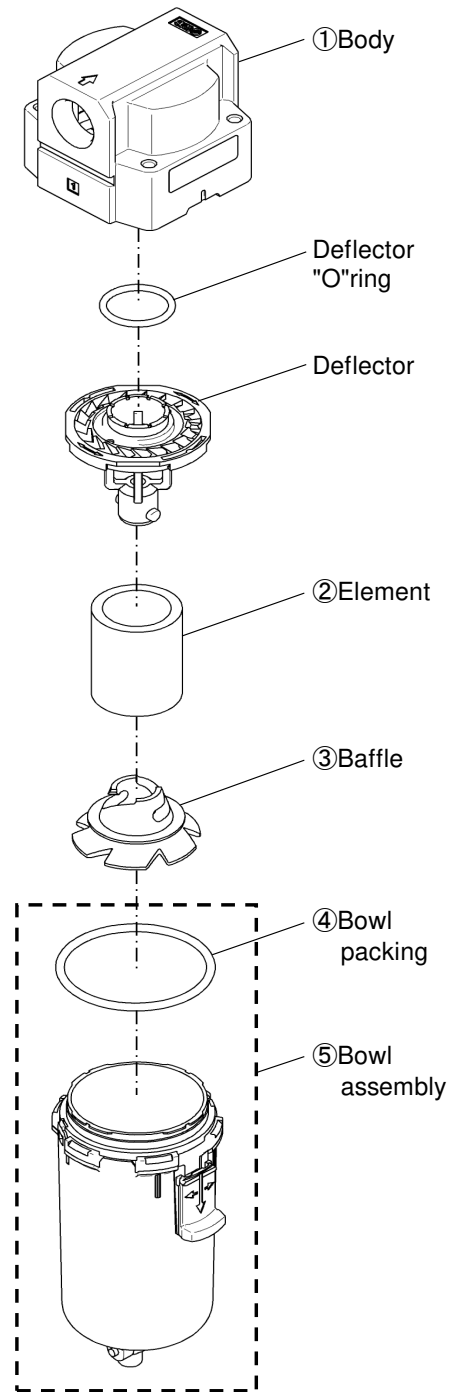

4) AF50,60-A

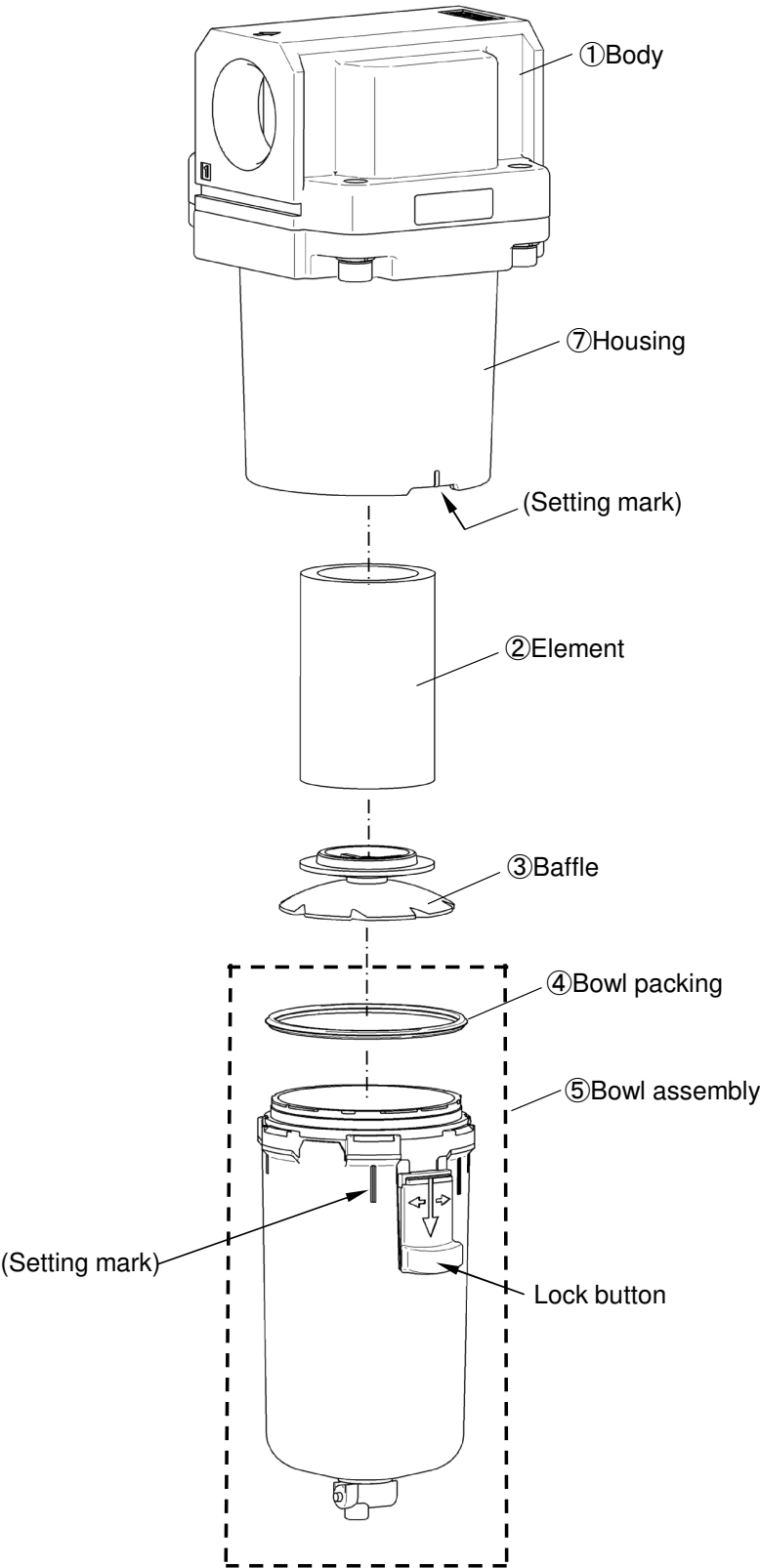

# 11. DIMENSIONS

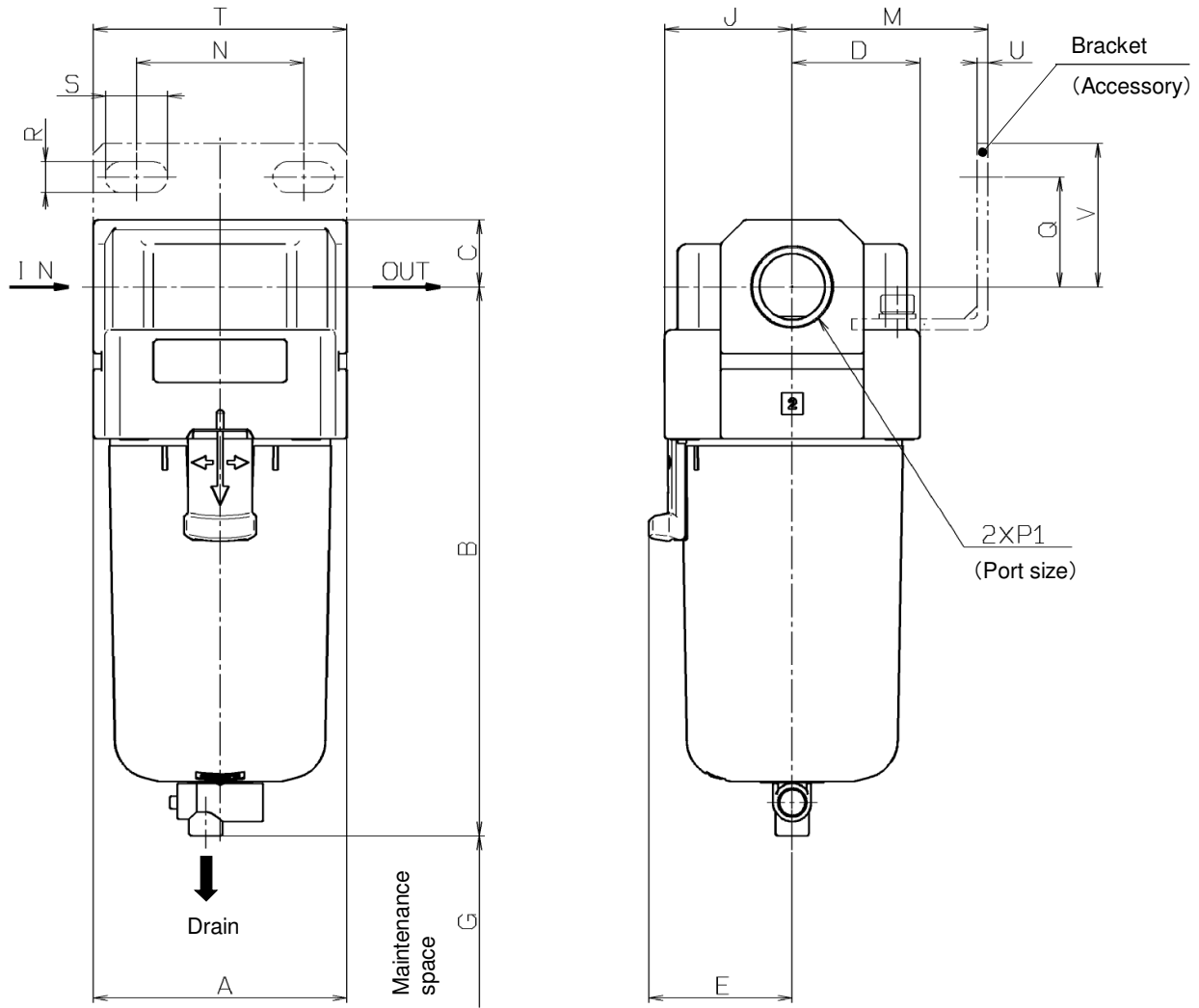

Model	Standard specifications							
	P1	A	B	C	D	E	G	J
AF10-A	M5	25	59.9	7	12.5	—	25	12.5
AF20-A	1/8·1/4	40	87.6	9.8	20	—	25	20
AF30-A	1/4·3/8	53	115.1	14	26.7	30	35	26.7
AF40-A	1/4·3/8·1/2	70	147.1	18	35.5	38.4	40	35.5
AF40-06-A	3/4	75	149.1	20	35.5	38.4	40	35.5
AF50-A	3/4·1	90	220.1	24	45	—	30	45
AF60-A	1	95	234.1	24	47.5	—	30	47.5

Model	Bracket mount dimensions							
	M	N	Q	R	S	T	U	V
AF10-A	—	—	—	—	—	—	—	—
AF20-A	30	27	22	5.4	8.4	40	2.3	28
AF30-A	41	35	23	6.5	13	53	2.3	30
AF40-A	50	52	26	8.5	12.5	70	2.3	35
AF40-06-A	50	52	25	8.5	12.5	70	2.3	34
AF50-A	70	66	35	11	13	90	3.2	47
AF60-A	70	66	35	11	13	90	3.2	47

### Dimension: B of auto-drain and optional bowl assembly

	Optional		C														D								
	Standard	Semi-standard	2	6	8	C	6C	J	2J	6J	8J	CJ	6CJ	W	6W	—	2	6	8						
AF10-A	59.3	59.9	—	—	—	—	—	—	—	—	—	—	—	—	—	77.9	77.9	77.9	—	—	—	—			
AF20-A	87.4	87.6	—	87.6	87.6	91.4	93.9	91.4	—	91.4	91.4	—	—	—	—	104.9	104.6	104.9	—	104.9	104.9	—	—	—	
AF30-A	117.6	115.1	137.6	—	—	121.9	122.1	121.9	142.1	—	—	—	123.6	123.6	156.8	156.8	156.8	156.8	—	—	—	156.8	156.8	156.8	156.8
AF40-A	149.6	147.1	169.6	—	—	153.9	154.1	153.9	174.1	—	—	—	155.6	155.6	186.9	188.8	186.9	188.8	—	—	—	186.9	188.8	186.9	188.8
AF40-06-A	151.6	149.1	171.6	—	—	155.9	156.1	155.9	176.1	—	—	—	157.6	157.6	188.9	190.8	188.9	190.8	—	—	—	188.9	190.8	188.9	190.8
AF50-A	222.6	220.1	242.6	—	—	226.9	227.1	226.9	247.1	—	—	—	228.6	228.6	259.9	261.8	259.9	261.8	—	—	—	259.9	261.8	259.9	261.8
AF60-A	236.6	234.1	256.6	—	—	240.9	241.1	240.9	261.1	—	—	—	242.6	242.6	273.9	275.8	273.9	275.8	—	—	—	273.9	275.8	273.9	275.8

Note 1) The specifications of auto-drain and optional bowl assembly are described in 「8. SPECIFICATIONS OF BOWL ASSEMBLY」(P11 to P19).



#### Revision history

<b>A</b>	Model (AF10-A,AF50-A,AF60-A) and Option (-2,-6,-8) addition.	2015.6
<b>B</b>	• P4 Fluorine grease is added. • P8 Shape changing of bracket. • P30 The page is deleted. • 11. DIMENSIONS option addition, Shape changing of bracket.	2018.1
<b>C</b>	• P4 Correction: 「Maintenance」 CAUTION④ • P23 Change:bowl tightening torque(AF20-A) • P30 Correction: E dimensions(AF50~60-A) N, S dimensions(AF30~40-A)	2021.12
<b>D</b>	• Sayfety Instructions : Revision	2024.9

## SMC Corporation

Tel: + 81 3 5207 8249 Fax: +81 3 5298 5362  
URL <https://www.smcworld.com>

Note: Specifications are subject to change without prior notice and any obligation on the part of the manufacturer.  
© SMC Corporation All Rights Reserved