



Operation Manual

Product Name

Auto Drain Valve

Model / Series / Product Number

AD402(T)-(F,N)02~(F,N)04(C,D)(-2,6,R,V,Z)-A

SMC Corporation

Contents

	PAGE
1. Safety instructions	1~7
2. Application	8
3. Specifications	8
4. How to order	9
5. Working principle	10
6. Troubleshooting	11~13
7. Construction / Parts list	14
8. Bowl assembly specifications	15
9. Replacement procedure	16~17
10. Disassembly drawing	18
11. Dimensions	19~20

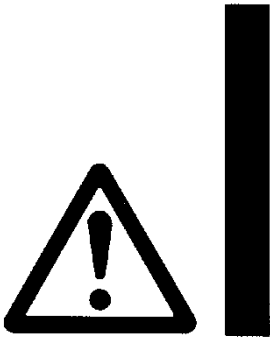

Safety Instructions

These safety instructions are intended to prevent hazardous situations and/or equipment damage. These instructions indicate the level of potential hazard with the labels of “**Caution**,” “**Warning**” or “**Danger**.” They are all important notes for safety and must be followed in addition to International Standards (ISO/IEC)^{*)}, and other safety regulations.

*1) ISO 4414: Pneumatic fluid power - General rules and safety requirements for systems and their components
ISO 4413: Hydraulic fluid power - General rules and safety requirements for systems and their components
IEC 60204-1: Safety of machinery - Electrical equipment of machines - Part 1: General requirements
ISO 10218-1: Robots and robotic devices - Safety requirements for industrial robots - Part 1: Robots
etc.

	Danger	Danger indicates a hazard with a high level of risk which, if not avoided, will result in death or serious injury.
	Warning	Warning indicates a hazard with a medium level of risk which, if not avoided, could result in death or serious injury.
	Caution	Caution indicates a hazard with a low level of risk which, if not avoided, could result in minor or moderate injury.

Warning

1. The compatibility of the product is the responsibility of the person who designs the equipment or decides its specifications.

Since the product specified here is used under various operating conditions, its compatibility with specific equipment must be decided by the person who designs the equipment or decides its specifications based on necessary analysis and test results. The expected performance and safety assurance of the equipment will be the responsibility of the person who has determined its compatibility with the product. This person should also continuously review all specifications of the product referring to its latest catalog information, with a view to giving due consideration to any possibility of equipment failure when configuring the equipment.

2. Only personnel with appropriate training should operate machinery and equipment.

The product specified here may become unsafe if handled incorrectly. The assembly, operation and maintenance of machines or equipment including our products must be performed by an operator who is appropriately trained and experienced.

3. Do not service or attempt to remove product and machinery/equipment until safety is confirmed.

1. The inspection and maintenance of machinery/equipment should only be performed after measures to prevent falling or runaway of the driven objects have been confirmed.
2. When the product is to be removed, confirm that the safety measures as mentioned above are implemented and the power from any appropriate source is cut, and read and understand the specific product precautions of all relevant products carefully.
3. Before machinery/equipment is restarted, take measures to prevent unexpected operation and malfunction.

4. Our products cannot be used beyond their specifications. Our products are not developed, designed, and manufactured to be used under the following conditions or environments. Use under such conditions or environments is not covered.

1. Conditions and environments outside of the given specifications, or use outdoors or in a place exposed to direct sunlight.
2. Use for nuclear power, railways, aviation, space equipment, ships, vehicles, military application, equipment affecting human life, body, and property, fuel equipment, entertainment equipment, emergency shut-off circuits, press clutches, brake circuits, safety equipment, etc., and use for applications that do not conform to standard specifications such as catalogs and operation manuals.
3. Use for interlock circuits, except for use with double interlock such as installing a mechanical protection function in case of failure. Please periodically inspect the product to confirm that the product is operating properly.

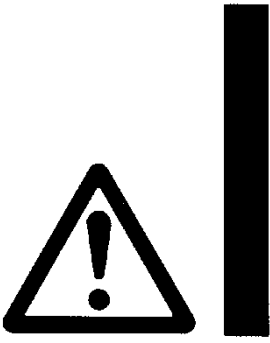

Safety Instructions

Caution

We develop, design, and manufacture our products to be used for automatic control equipment, and provide them for peaceful use in manufacturing industries.

Use in non-manufacturing industries is not covered.

Products we manufacture and sell cannot be used for the purpose of transactions or certification specified in the Measurement Act.

The new Measurement Act prohibits use of any unit other than SI units in Japan.

Limited warranty and Disclaimer/Compliance Requirements

The product used is subject to the following “Limited warranty and Disclaimer” and “Compliance Requirements”.

Read and accept them before using the product.

Limited warranty and Disclaimer

1. The warranty period of the product is 1 year in service or 1.5 years after the product is delivered, whichever is first.*2)

Also, the product may have specified durability, running distance or replacement parts. Please consult your nearest sales branch.

2. For any failure or damage reported within the warranty period which is clearly our responsibility, a replacement product or necessary parts will be provided.

This limited warranty applies only to our product independently, and not to any other damage incurred due to the failure of the product.

3. Prior to using SMC products, please read and understand the warranty terms and disclaimers noted in the specified catalog for the particular products.

***2) Vacuum pads are excluded from this 1 year warranty.**

A vacuum pad is a consumable part, so it is warranted for a year after it is delivered.

Also, even within the warranty period, the wear of a product due to the use of the vacuum pad or failure due to the deterioration of rubber material are not covered by the limited warranty

Compliance Requirements

1. The use of SMC products with production equipment for the manufacture of weapons of mass destruction (WMD) or any other weapon is strictly prohibited.

2. The exports of SMC products or technology from one country to another are governed by the relevant security laws and regulations of the countries involved in the transaction. Prior to the shipment of a SMC product to another country, assure that all local rules governing that export are known and followed.

Precautions on design

 **Warning**

1. The standard bowl for the auto drain valve is made of polycarbonate. Do not use in an environment where they are exposed to or come in contact with organic solvents, chemicals, cutting oil, synthetic oil, alkali and thread lock solutions.

Effects organic solvents and chemicals, and where these elements are likely to adhere to the equipment. Chemical data for substances causing degradation (Reference)

Type	Chemical name	Application examples	Material	
			Polycarbonate	Nylon
Acid	Hydrochloric acid Sulphuric acid, Phosphoric acid Chromic acid	Acid washing liquid for metals	△	×
Alkaline	Sodium hydroxide (Caustic soda) Potash Calcium hydroxide (Slack lime) Ammonia water Carbonate of soda	Degreasing of metals Industrial salts Water-soluble cutting oil	×	Good
Inorganic salts	Sodium sulphide Sulphate of potash Sulphate of soda	-	×	△
Chlorine solvents	Carbon tetrachloride Chloroform Ethylene chloride Methylene chloride	Cleaning liquid for metals Printing ink Dilution	×	△
Aromatic series	Benzene Toluene Paint thinner	Coatings Dry cleaning	×	△
Ketone	Acetone Methyl ethyl ketone Cyclohexane	Photographic film Dry cleaning Textile industries	×	×
Alcohol	Ethyl alcohol IPA Methyl alcohol	Antifreeze Adhesives	△	×
Oil	Gasoline Kerosene	-	×	Good
Ester	Phthalic acid dim ethyl Phthalic acid diethyl Acetic acid	Synthetic oil Anti-rust additives	×	Good
Ether	Methyl ether Ethyl ether	Brake oil additives	×	Good
Amino	Methyl amino	Cutting oil Brake oil additives Rubber accelerator	×	×
Others	Thread -lock fluid Seawater Leak tester	-	×	△

○: Essentially safe △: Some effects may occur ×: Effects will occur

When the above factors are present, or there is some doubt, use a metal case for safety.

2. Keep the compressed air and the ambient temperature of the location where this product is installed within the range of -5 to 60°C. Exceeding this range could lead to a failure or malfunction.
3. Avoid using this product in an area where corrosive gases, flammable gases or organic solvents are contained in the compressed air or in the surrounding air.

Selection



Caution

1. Use an auto drain valve under the following conditions to avoid malfunction.

<N.O. type>

- Operating pressure: 0.1MPa or more
- Operating compressor: 3.7 kW (400 L/min [ANR]) or more

Air may ceaselessly blow out of the drain discharge area when an air compressor with a small air discharge volume is used since the valve does not close unless the air pressure is 0.1MPa or higher.

<N.C. type>

- Operating pressure: 0.15MPa or more

2. Operation failure will occur if a large amount of drain is supplied into the valve. Do not use the auto drain valve in such environment.

Piping



Warning

1. Hold the female screw side and tighten to the recommended torque when screwing in the piping material. Insufficient tightening torque may cause loosening or defective sealing. Excessive tightening torque may damage the thread etc. If it is tightened without holding female thread side, excessive force will be directly applied to the internal parts resulting in a product failure.

Recommended torque	Unit: Nm		
Connection thread	1/4	3/8	1/2
Torque	12 to 14	22 to 24	28 to 30

Caution

1. Before piping is connected, it should be thoroughly blown out with air (flushing) or washed to remove chips, cutting oil and other debris from inside the pipe.
2. When screwing piping or fittings into ports, ensure that chips from the pipe threads or sealing material do not enter the piping. Also, if pipe tape is used, leave 1 thread ridges exposed at the end of the threads.
3. Before using an SMC fitting and S coupler, please refer to "Tightening the threaded portion of the connection thread" of the Fittings & Tubing Precautions.
4. For drain pipe, use piping which has an I.D. of Ø10 or larger and length of 5 m or less. Avoid riser piping.

Mounting

Caution

1. Install the auto drain valve with "Drain port" down in vertical position. If it is installed diagonally, laterally, or upside down, the drain will splash to the drain port.
2. Install with at least 30 mm of free space down the product to allow for maintenance.
3. To place this product near the air compressor, install in such a way that the vibrations will not be transmitted.
4. When the bowl is installed on the product, install them so that the lock button lines up the boss of the front (or the back) of the body to avoid drop or damage of the bowl.

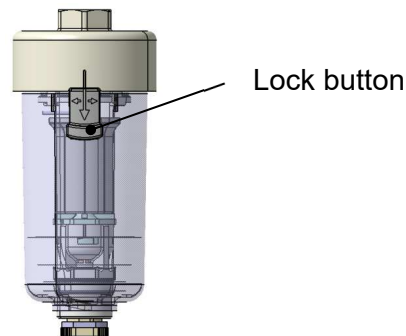

Air supply

Caution

1. The auto drain valve is not applicable to gases other than compressed air (example: oxygen, hydrogen, flammable gas, mixed gas).
2. Do not use compressed air that contained chemicals, organic solvents, salts, or corrosive gases. That can cause rust, damage to rubber and resin parts, or malfunction.
3. Operate within the specified operating pressure range. Damage, failure, or malfunction may occur if the auto drain valve is operated above the maximum operating pressure.

Operating environment

Warning

1. Do not use in explosive atmosphere.
2. Do not use in locations subject to vibration or impact.
3. A protective cover should be used to shield the auto drain valve from direct sunlight.
4. Shield the auto drain valve from radiated heat generated by nearby heat sources.

Maintenance

Warning

1. Perform maintenance inspection according to the procedures indicated in the operation manual. If handled improperly, malfunction and damage of machinery or equipment may occur.
2. Perform periodical inspections to detect any cracks, scratches, or other deterioration of transparent resin bowl of the auto drain valve. Replace with a new bowl or metal bowl when any kind of deterioration is found. Otherwise, damage may occur. Investigate and/or review the operating conditions if necessary.
3. Use a mild household cleanser to clean the dirt on the bowl. Do not use any other cleaning agents. Otherwise, this can cause damage.

Caution

1. A manual knob attached to the auto drain valve end is tightened to the "S" side in normal operation. The drain can be discharged by loosening it to "O" side. (Be careful, however, if pressure remains inside the bowl when the drain is discharged, the drain will blow out from the drain port.)

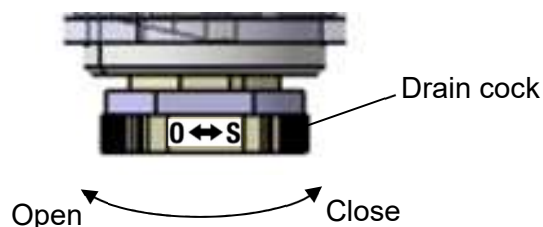

2. When releasing the drain manually, avoid applying excessive torque to the drain cock, such as by using a tool, as this can cause damage.

3. When removing the bowl, ensure the lock button pushes down from the dent in the body to release the lock before proceeding. It may damage the lock button.
4. During removal, if it is hard to rotate the bowl, lift it upwards then rotate it.

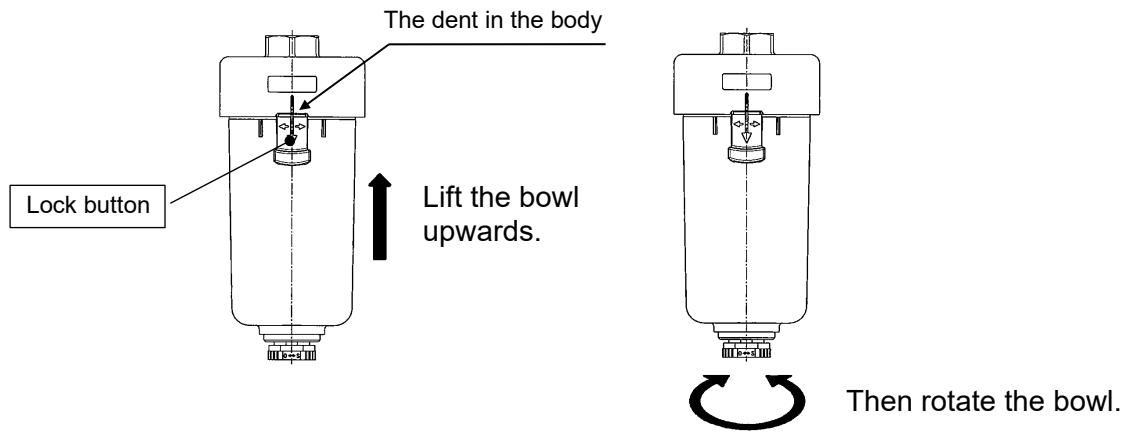

2. Applications

This product intends to discharge the collected drain automatically.

3. Standard specifications

Model		AD402-A	AD402T-A
Port direction		Vertical	Side
Auto drain type		Float type	
Auto drain valve type		N.C. (Normal close: Drain port is closed when pressure is not applied.) N.O. (Normal open: Drain port is open when pressure is not applied.)	
Fluid		Air	
Ambient and fluid temperature		-5 to 60°C (No freezing)	
Proof pressure		1.5MPa	
Max. operating pressure		1.0MPa	
Operating pressure range <small>Note)</small>	N. C.	0.15 to 1.0MPa	
	N. O.	0.1 to 1.0MPa	
Port size		1/4, 3/8, 1/2	
Drain port size		3/8	
Bowl material		Polycarbonate	
Bowl guard material		Polycarbonate	
Weight		0.46kg	0.52kg
Paint color		White	

Note) Use for an air compressor with rated flow of more than 400 L/min [ANR]

4. How to order

AD402 - 04 D - - A

Port direction ●

Symbol	Direction
Nil	Vertical
T	Side

Thread type ●

Symbol	Type
Nil	Rc
F	G
N	NPT

Port size ●

Symbol	Size
02	1/4
03	3/8
04	1/2

Auto drain type ●

Symbol	Description
C ^{Note1)}	N.C. (Normal close: Drain port is closed when pressure is not applied.)
D ^{Note2)}	N.O. (Normal open: Drain port is open when pressure is not applied.)

Note 1) When pressure is not applied, condensate which does not start the auto drain mechanism will be left in the bowl. Releasing the residual condensate before ending operations for the day is recommended.

Note 2) If the compressor is small (3.7 kW, discharge flow is less than 400 L/min [ANR]), air leakage from drain cock may occur during start of operations. N.C. type is recommended.

● Semi-standard

1) Bowl ^{Note3)}

Symbol	Description
Nil	Polycarbonate bowl
2	Metal bowl
6	Nylon bowl

Note 3) Refer to Chemical data on page 3 for chemical resistance data of the bowl..

+

2) Flow direction ^{Note4)}

Symbol	Description	
Nil	IN port left side	
R	IN port right side	

Note 4) Applies to side piping only. Indicates the direction of the port when the product label is viewed from the front.

+

3) Valve

Symbol	Description
Nil	Without bleed valve ^{Note5)}
V	With bleed valve

Note 5) Not available for port size 1/4 as it comes with a bleed valve.

+

4) Pressure unit

Symbol	Description
Nil	Name plate and caution plate for bowl in imperial units : MPa
Z ^{Note6)}	Name plate and caution plate for bowl in imperial units : psi

Note 6) For thread type: NPT only. This product is for overseas use only according to the new Measurement Law. (The SI unit type is provided for use in Japan.)

5. Working principle

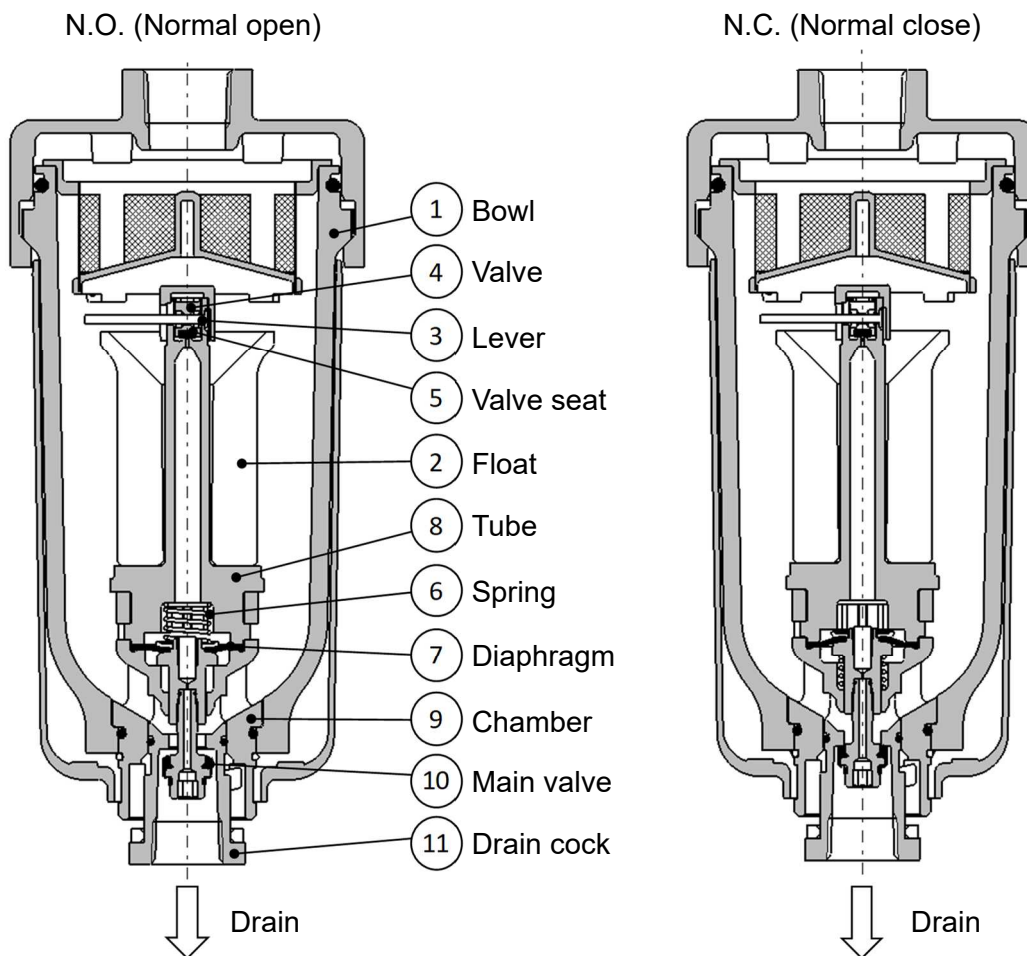

●When pressure inside the bowl is released:
When pressure is released from the bowl ①, diaphragm ⑦ is lowered by spring ⑥. The sealing action of main valve ⑩ is interrupted, and the outside air flows inside the bowl ① through chamber hole ⑨ and drain cock ⑪. Therefore, if there is an accumulation of condensate in the bowl ①, it will drain out through the drain cock ⑪.

●When pressure is applied inside the bowl:
When pressure exceeds 0.1MPa, the force of diaphragm ⑦ surpasses the force of spring ⑥, and the diaphragm goes up. This pushes main valve ⑩ up so that it creates a seal, and the inside of the bowl ①, is shut off from the outside air. If there is no accumulation of condensate in the bowl ① at this time, float ② will be pulled down by its own weight, causing valve ④, which is connected to lever ③, to seal valve seat ⑤.

●When there is an accumulation of condensate in the bowl:
Float ② rises due to its own buoyancy and pushes open the seal created by the valve seat ⑤. This allows the pressure inside the bowl ① to enter the tube ⑧. The result is that the force of the spring ⑥ lowers the diaphragm ⑦. This causes the sealing action of main valve ⑩ to be interrupted, and the accumulated condensate in the bowl ① drains out through the drain cock ⑪. Turning drain cock ⑪ manually counterclockwise rises drain cock ⑪, which pushes open the seal created by main valve ⑩, thus allowing the condensate to drain out.

●When pressure inside the bowl is released:
Even when pressure inside the bowl ① is released, spring ⑥ keeps diaphragm ⑦ in its upward position. This keeps the seal created by the main valve ⑩ in place; thus, the inside of the bowl ① is shut off from the outside air. Therefore, even if there is an accumulation of condensate in the bowl ①, it will not drain out.

●When pressure is applied inside the bowl:
Even when pressure is applied inside the bowl ①, the combined force of spring ⑥ and the pressure inside the bowl ① keeps diaphragm ⑦ in its upward position. This maintains the seal created by the main valve ⑩ in place; thus, the inside of the bowl ① is shut off from the outside air. If there is no accumulation of condensate in the bowl ① at this time, float ② will be pulled down by its own weight, causing valve ④, which is connected to lever ③, to seal valve seat ⑤.

●When there is an accumulation of condensate in the bowl:
Float ② rises due to its own buoyancy and pushes open the seal created by the valve seat ⑤. This allows the pressure inside the bowl ① to enter the tube ⑧. The result is that the force of the spring ⑥ lowers the diaphragm ⑦. This causes the sealing action of main valve ⑩ to be interrupted, and the accumulated condensate in the bowl ① drains out through the drain cock ⑪. Turning drain cock ⑪ manually counterclockwise rises drain cock ⑪, which pushes open the seal created by main valve ⑩, thus allowing the condensate to drain out.

6. Troubleshooting

Product break-down		Possible causes	Countermeasure
Category	Failure mode		
Air leaks	Air leaks between the bowl and the body.	1. Bowl o-ring is damaged.	1. Replace the bowl o-ring. Grease up before assembling. ^(Note)
	Air leaks from the bowl.	1. Bowl is damaged.	1. Replace the bowl assembly. Replace the nylon bowl or metal bowl.
	Air leaks between the bowl and the internal assembly.	1. Chamber o-ring is damaged.	1. Replace the bowl assembly.
	Air leaks between the internal assembly and the drain cock.	1. Drain cock o-ring is damaged.	1. Replace the bowl assembly.
	Drain or air keeps being discharged from the drain port.	1. Installed diagonally.	1. Install vertically.
		2. Clogging the orifice of internal assembly.	2. Replace the bowl assembly.
		3. Valve is damaged.	3. Replace the bowl assembly.
		4. Sealing failure of valve.	4. Replace the bowl assembly.
		5. Diaphragm is damaged.	5. Replace the bowl assembly.
		6. Main valve is damaged.	6. Replace the bowl assembly.
7. Sealing failure of main valve.		7. Replace the bowl assembly.	
8. Drain piping is too long or I.D. of piping is too small. (exhaust pressure is applied).	8. For drain pipe, use piping which I.D. is Ø10mm or larger, and whose length is 5 m or less. Avoid riser piping.		
9. Loose drain cock.	9. Tighten a manual knob of drain cock to the "S" side		

Product break-down		Possible causes	Countermeasure
Category	Failure mode		
Operational	Collected drain is not discharged.	1. The supply pressure exceeds the operating pressure range.	1. Use the product within the specified pressure range.
		2. Tube nozzle is clogged.	2. Remove the clogging by blowing the tube nozzle with air. Alternatively, replace the bowl assembly.
		3. Lever operation failure.	3. Confirm smooth operation by blowing the lever with air. Alternatively, replace the bowl assembly.
		4. Float operation failure.	4. Confirm smooth operation by cleaning the float and blowing it with air. Alternatively, replace the bowl assembly.
	Drain is not discharged even when rotating the drain cock to "O" side of the manual knob.	1. Drain cock outlet is clogged.	1. Remove the clogging by cleaning the drain cock and blowing it with air. Alternatively, replace the bowl assembly.
	Drain does not enter the bowl.	1. Element is clogged.	1. Remove the clogging by cleaning the element and blowing it with air. Alternatively, replace the element.
		2. Piping length of the IN side is excessively long or piping I.D. is restricting adequate flow of drain.	2. Review the length and I.D of piping. Alternatively, replace the product with a bleed valve type auto drain and open the valve to reduce the pressure in the bowl.

Note) Grease pack for maintenance "GR-F-###" is recommended for use.

Grease pack No.

No.	Mass(g)
GR-F-005	5
GR-F-050	50
GR-F-100	100
GR-F-200	200
GR-F-500	500

7. Construction / Parts list

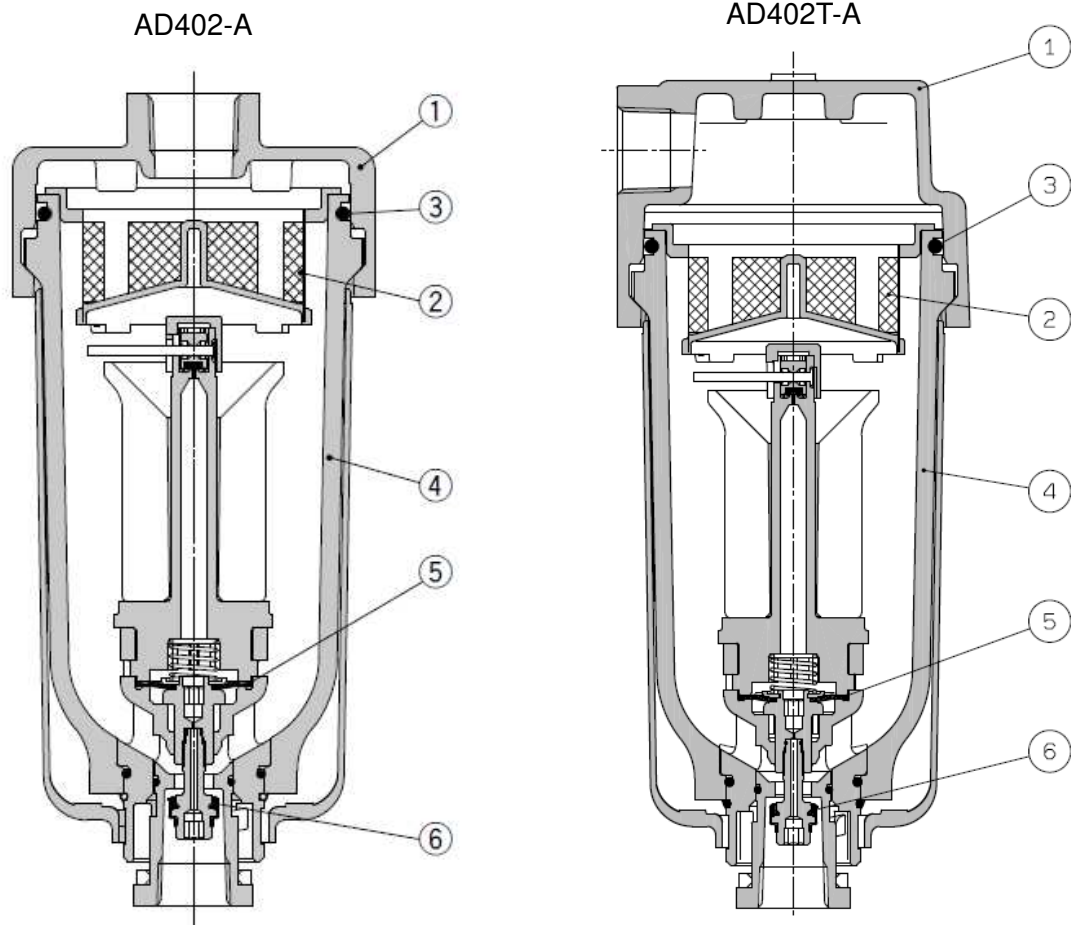

Component parts

No.	Description	Material	Color
1	Body	Aluminum die-cast	White
5	Diaphragm	FKM	-
6	Main valve	FKM	-

Replacement parts

No.	Description	Material	Part No.
2	Element	Nylon	AD402P-040S
3	Bowl O-ring	NBR	KA00463
4	Bowl assembly ^{Note)}	Refer to the following table	

Bowl assembly part no.

Bowl material	Bowl assembly Part No.	
	N.O. type	N.C. type
Polycarbonate	Please refer to "8. Bowl assembly specifications."	
Nylon		
Metal		

Note) Bowl assembly comes with a bowl o-ring.

8. Bowl assembly specifications

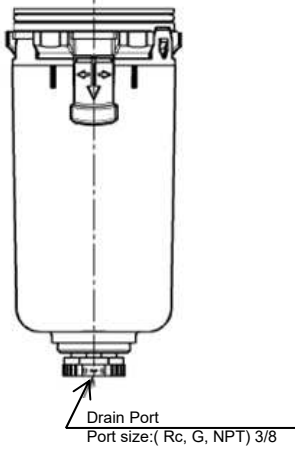
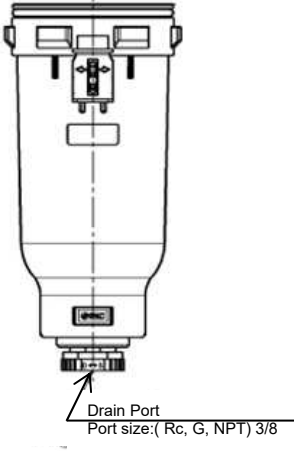
Auto-drain type			N.O. type			
Semi-standard symbol			-	6	2	
Appearance						
						Part No.
			G	AD52F-A	AD52F-6-A	AD52F-2-A
		NPT		AD52N-A	AD52N-6-A	AD52N-2-A
				AD52N-Z-A	AD52N-6Z-A	AD52N-2Z-A

Note1) "Z" in the part number indicates a semi-standard specification, in which the units for pressure and temperature are psi and °F.

Note2) The symbol for semi-standard is described as "4. HOW TO ORDER"

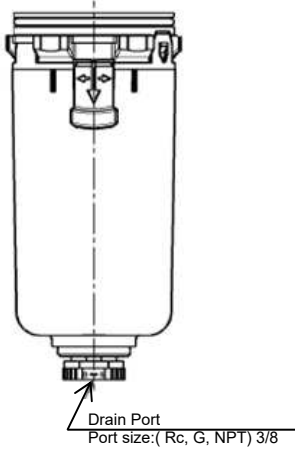
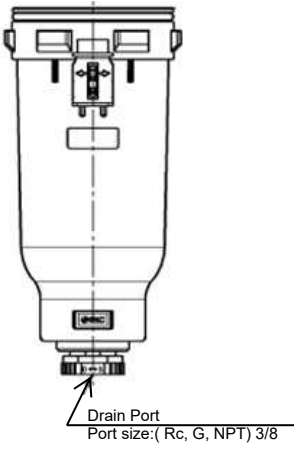
Auto-drain type			N.C. type			
Semi-standard symbol			-	6	2	
Appearance						
						Part No.
			G	AD51F-A	AD51F-6-A	AD51F-2-A
		NPT		AD51N-A	AD51N-6-A	AD51N-2-A
				AD51N-Z-A	AD51N-6Z-A	AD51N-2Z-A

Note1) "Z" in the part number indicates a semi-standard specification, in which the units for pressure and temperature are psi and °F.

Note2) The symbol for semi-standard is described as "4. HOW TO ORDER"

9. Replacement procedure

Warning

Before replacement, ensure that the auto drain valve is not pressurized.

After replacement, ensure that the specified function is satisfied and external leakage is not found before starting operation.

Procedure	What to do	To do list
1	Remove bowl assembly	Remove the bowl assembly by rotating it clockwise or counterclockwise by 30 degrees, sliding the lock button of the bowl assembly downwards. (When the setting mark of the body and bowl assembly meet, it means they have rotated by 30 degrees) * If it is hard to rotate the bowl, lift it upward then rotate it.
2	Remove element	Hold the boss of the element center to take it out of the bowl.
3	Remove bowl o-ring	Remove the bowl O-ring from the groove on the outer circumference of the bowl.
4	Remove bowl guard assembly	After releasing the engagement of the bowl guard concave and convex of the bowl, pull out the bowl guard assembly from the bowl.
5	Remove internal assembly	After removing the C-ring, remove the internal assembly from the bowl.

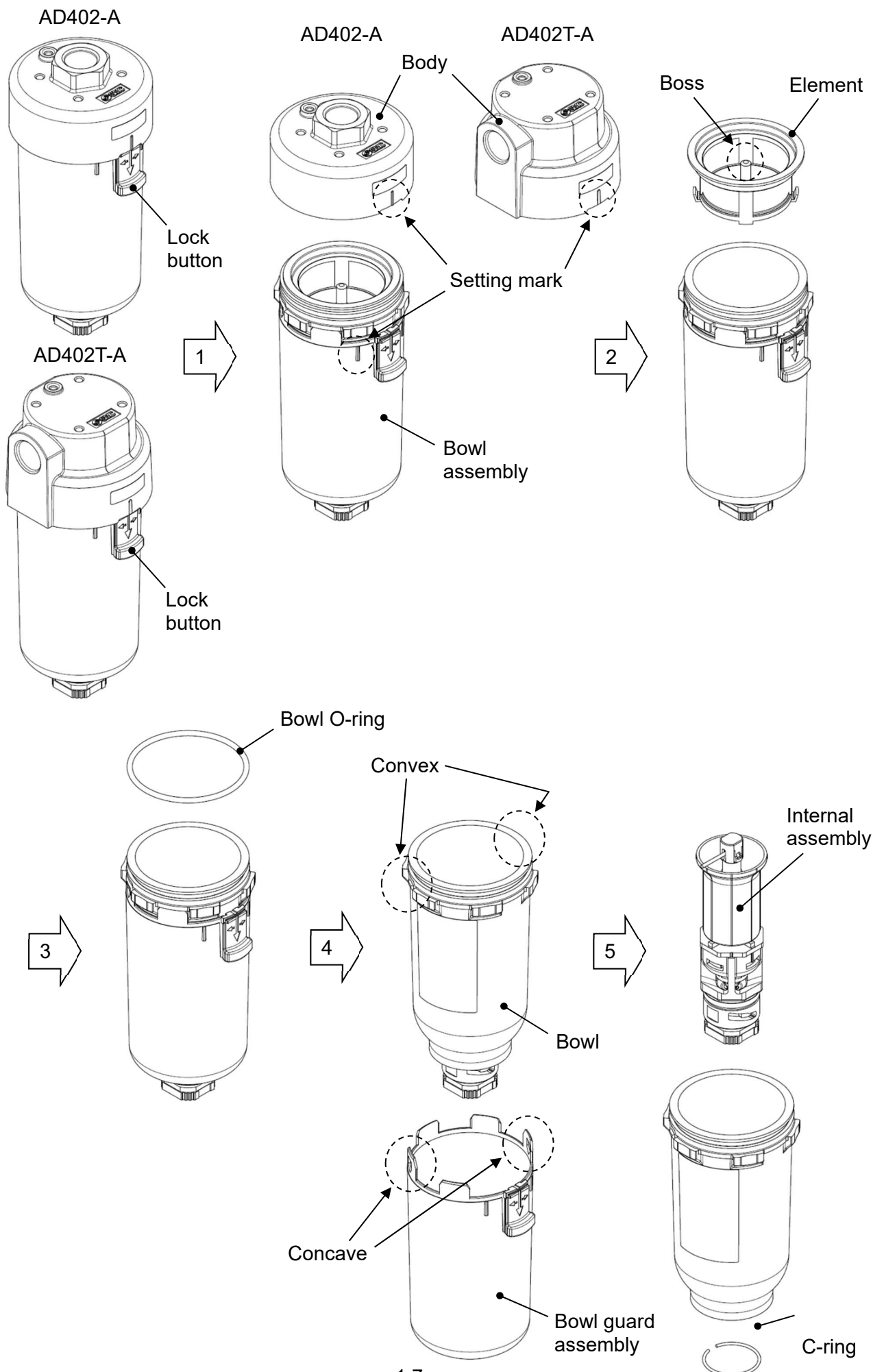

10. Disassembly drawing

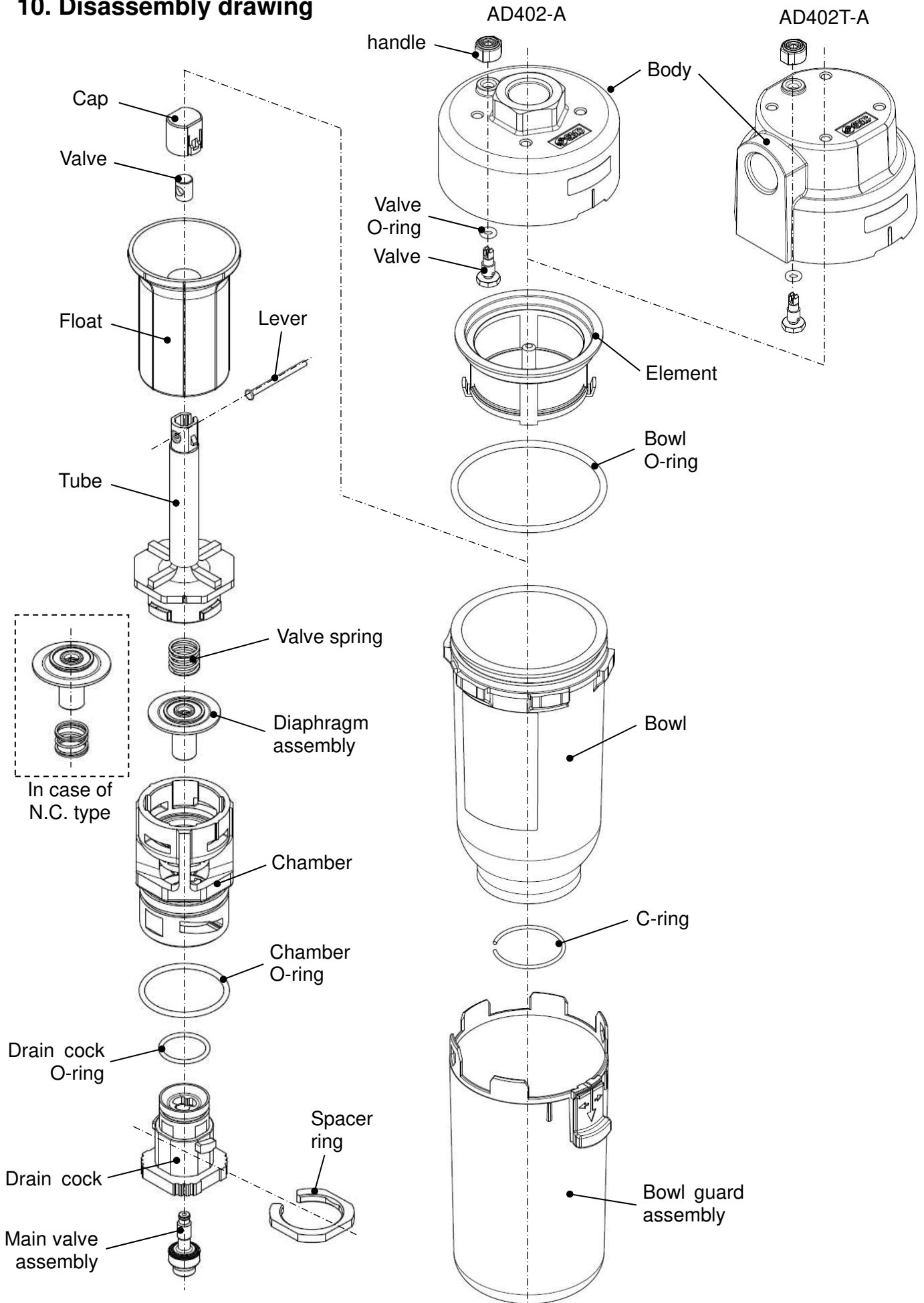

11. Dimensions

AD402-A

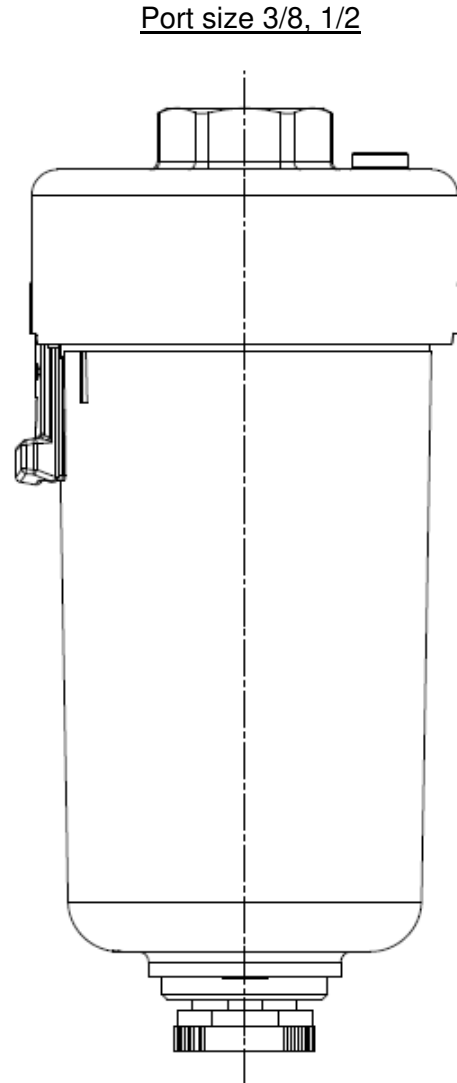
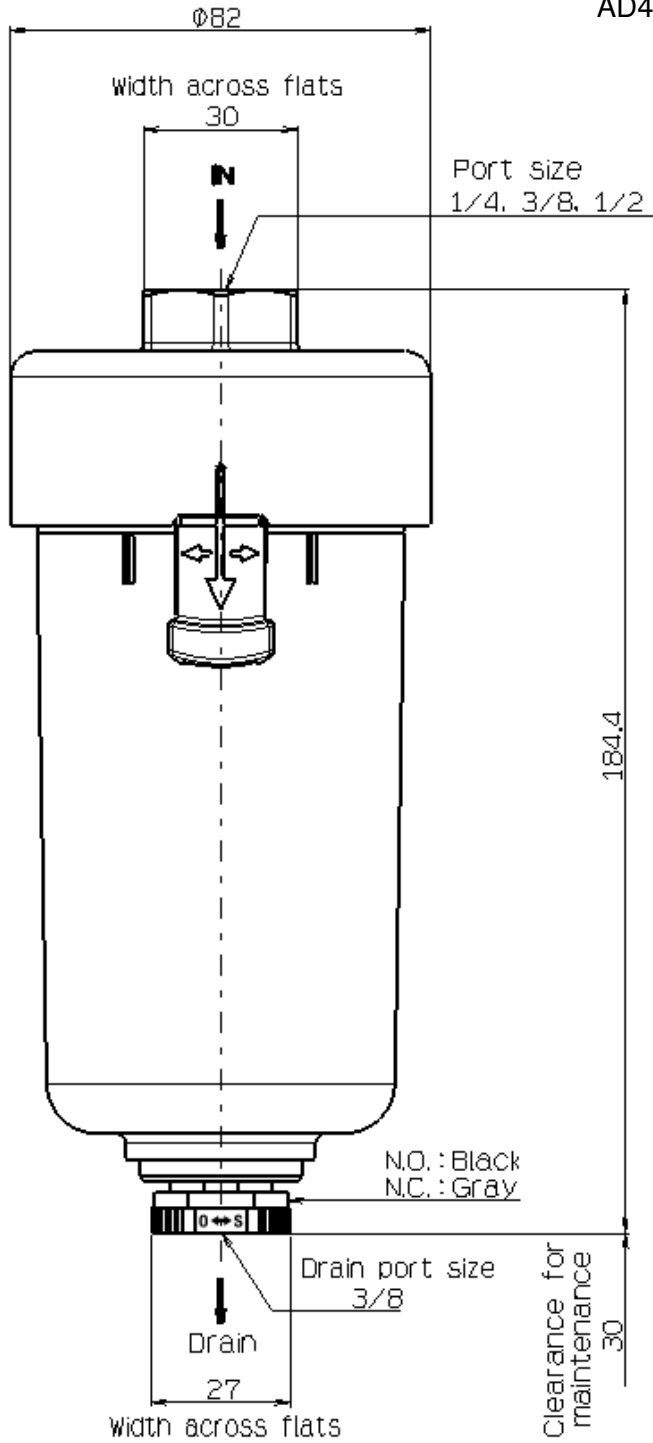

[With bleed valve] Port size 1/4, and Port size 3/8, 1/2 with "V" option

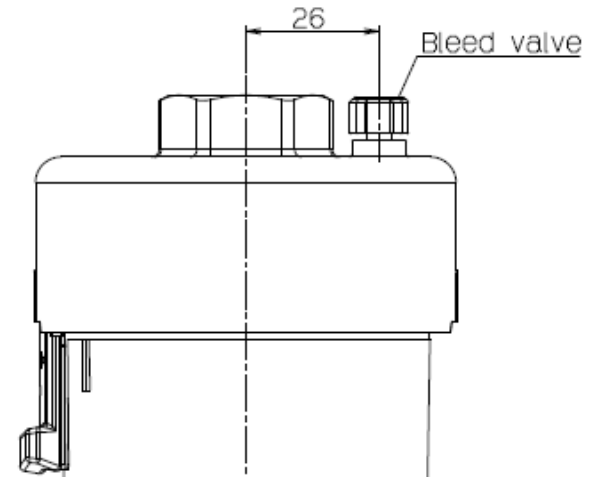

Port size 3/8, 1/2

AD402T-A

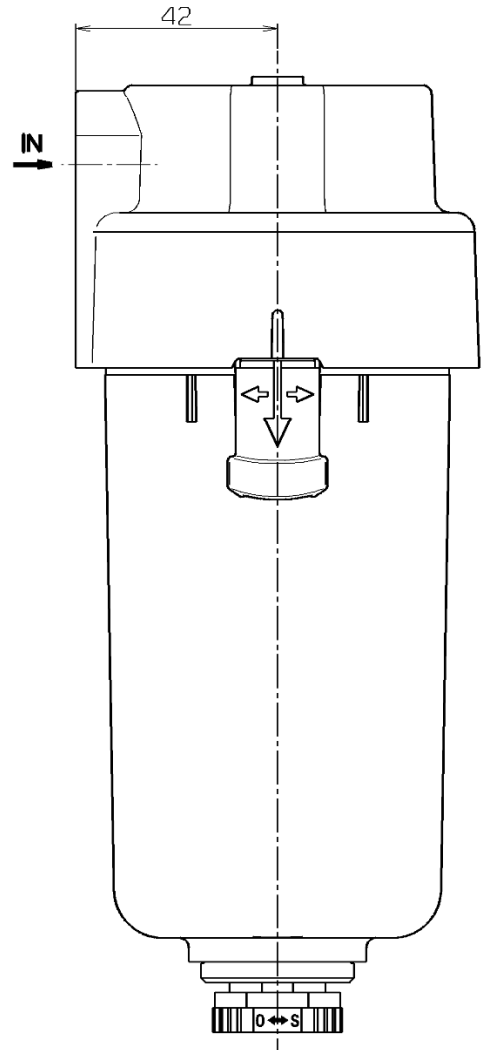
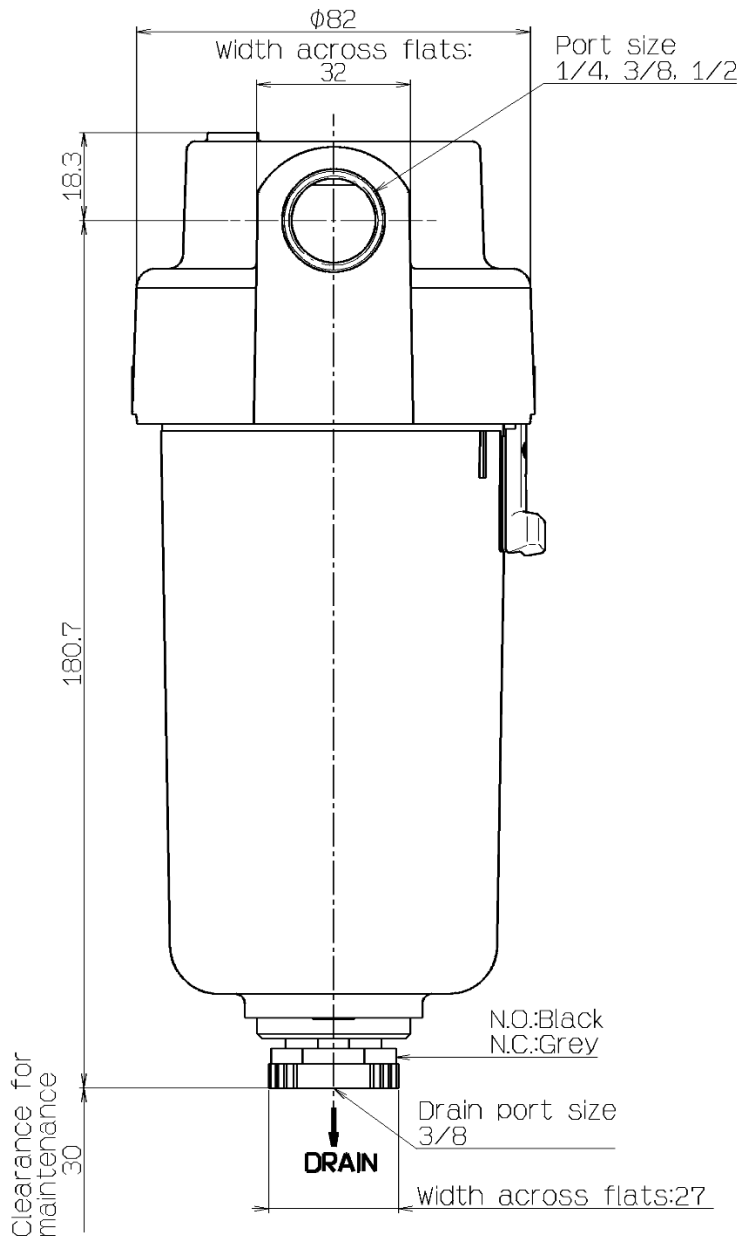

[With bleed valve] Port size 1/4, and
Port size 3/8, 1/2 with "V" option

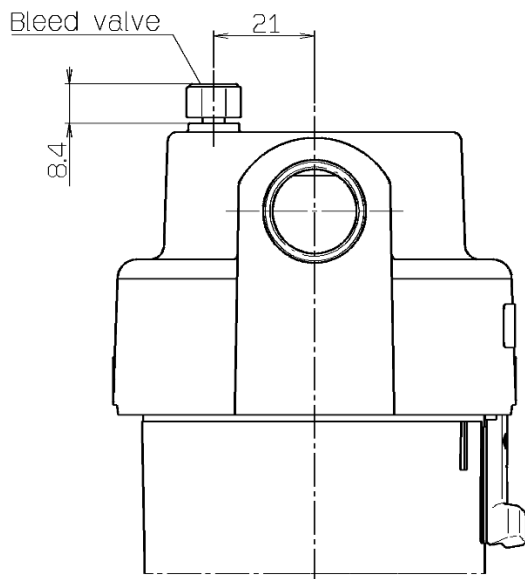

Revision history	
A: Addition of method of detaching bowl.	2017.08
B: Side piping specification added.	2022.12
C: Change : Safety instructions Addition : Method of detaching bowl "Bowl assembly specifications" Grease pack No.	2026.04

SMC Corporation

Tel: + 81 3 5207 8249 Fax: +81 3 5298 5362

URL <https://www.smcworld.com>

Note: Specifications are subject to change without prior notice and any obligation on the part of the manufacturer.
© SMC Corporation All Rights Reserved