



Operation Manual

PRODUCT NAME

Air Filter

MODEL / Series / Product Number

25A-AF20- (F, N) 01 ~ (F, N) 02 (B) (-R, Z) -D

25A-AF30- (F, N) 02 ~ (F, N) 03 (B) (-R, Z) -D

25A-AF40- (F, N) 02 ~ (F, N) 04 (B) (-R, Z) -D

25A-AF40- (F, N) 06 (B) (-R, Z) -D

25A-AF50- (F, N) 06 ~ (F, N) 10 (B) (-R, Z) -D

25A-AF60- (F, N) 10 (B) (-R, Z) -D

SMC Corporation

Contents

	Page
1. Safety Instructions	2-6
2. Application	7
3. Standard Specifications	7
4. How to Order	8
5. Structural Drawing, Option and Replacement Parts	9
6. Bowl Assembly Specifications	10
7. Assembly of Optional Parts	11
8. Operation and Adjustment	12
9. Trouble Shooting	13
10. How to Replace the Components	14-19
10-1. Bowl Assembly Replacement	14-16
10-2. Element Replacement	17-19
11. Disassembly Drawing	20
12. Dimensions	21



Safety Instructions

These safety instructions are intended to prevent hazardous situations and/or equipment damage. These instructions indicate the level of potential hazard with the labels of “**Caution**,” “**Warning**” or “**Danger**.” They are all important notes for safety and must be followed in addition to International Standards (ISO/IEC)^{*1)}, and other safety regulations.

*1) ISO 4414: Pneumatic fluid power - General rules and safety requirements for systems and their components
ISO 4413: Hydraulic fluid power - General rules and safety requirements for systems and their components
IEC 60204-1: Safety of machinery - Electrical equipment of machines - Part 1: General requirements
ISO 10218-1: Robots and robotic devices - Safety requirements for industrial robots - Part 1: Robots
etc.



Danger

Danger indicates a hazard with a high level of risk which, if not avoided, will result in death or serious injury.



Warning

Warning indicates a hazard with a medium level of risk which, if not avoided, could result in death or serious injury.



Caution

Caution indicates a hazard with a low level of risk which, if not avoided, could result in minor or moderate injury.

Warning

1. The compatibility of the product is the responsibility of the person who designs the equipment or decides its specifications.

Since the product specified here is used under various operating conditions, its compatibility with specific equipment must be decided by the person who designs the equipment or decides its specifications based on necessary analysis and test results. The expected performance and safety assurance of the equipment will be the responsibility of the person who has determined its compatibility with the product. This person should also continuously review all specifications of the product referring to its latest catalog information, with a view to giving due consideration to any possibility of equipment failure when configuring the equipment.

2. Only personnel with appropriate training should operate machinery and equipment.

The product specified here may become unsafe if handled incorrectly. The assembly, operation and maintenance of machines or equipment including our products must be performed by an operator who is appropriately trained and experienced.

3. Do not service or attempt to remove product and machinery/equipment until safety is confirmed.

1. The inspection and maintenance of machinery/equipment should only be performed after measures to prevent falling or runaway of the driven objects have been confirmed.
2. When the product is to be removed, confirm that the safety measures as mentioned above are implemented and the power from any appropriate source is cut, and read and understand the specific product precautions of all relevant products carefully.
3. Before machinery/equipment is restarted, take measures to prevent unexpected operation and malfunction.

4. Our products cannot be used beyond their specifications. Our products are not developed, designed, and manufactured to be used under the following conditions or environments. Use under such conditions or environments is not covered.

1. Conditions and environments outside of the given specifications, or use outdoors or in a place exposed to direct sunlight.
2. Use for nuclear power, railways, aviation, space equipment, ships, vehicles, military application, equipment affecting human life, body, and property, fuel equipment, entertainment equipment, emergency shut-off circuits, press clutches, brake circuits, safety equipment, etc., and use for applications that do not conform to standard specifications such as catalogs and operation manuals.
3. Use for interlock circuits, except for use with double interlock such as installing a mechanical protection function in case of failure. Please periodically inspect the product to confirm that the product is operating properly.



Safety Instructions

Caution

We develop, design, and manufacture our products to be used for automatic control equipment, and provide them for peaceful use in manufacturing industries.

Use in non-manufacturing industries is not covered.

Products we manufacture and sell cannot be used for the purpose of transactions or certification specified in the Measurement Act.

The new Measurement Act prohibits use of any unit other than SI units in Japan.

Limited warranty and Disclaimer/Compliance Requirements

The product used is subject to the following “Limited warranty and Disclaimer” and “Compliance Requirements”. Read and accept them before using the product.

Limited warranty and Disclaimer

1. The warranty period of the product is 1 year in service or 1.5 years after the product is delivered, whichever is first.*2)
Also, the product may have specified durability, running distance or replacement parts. Please consult your nearest sales branch.
2. For any failure or damage reported within the warranty period which is clearly our responsibility, a replacement product or necessary parts will be provided.
This limited warranty applies only to our product independently, and not to any other damage incurred due to the failure of the product.
3. Prior to using SMC products, please read and understand the warranty terms and disclaimers noted in the specified catalog for the particular products.

***2) Vacuum pads are excluded from this 1 year warranty.**

A vacuum pad is a consumable part, so it is warranted for a year after it is delivered.

Also, even within the warranty period, the wear of a product due to the use of the vacuum pad or failure due to the deterioration of rubber material are not covered by the limited warranty

Compliance Requirements

1. The use of SMC products with production equipment for the manufacture of weapons of mass destruction (WMD) or any other weapon is strictly prohibited.
2. The exports of SMC products or technology from one country to another are governed by the relevant security laws and regulations of the countries involved in the transaction. Prior to the shipment of a SMC product to another country, assure that all local rules governing that export are known and followed.

Precautions for Design

Warning

- (1) Do not use the product if no leakage is allowed due to the environment, or if the fluid is not air.
- (2) Polycarbonate resin is used for the external parts including the bowl. Organic solvents including thinner, acetone, alcohol and ethylene chloride; chemicals including sulphuric acid, nitric acid and hydrochloric acid; cutting oil, synthetic oils, ester-based compressor oil, alkali, kerosene, gasoline, lock material of screw are harmful. Do not use the product where these are present.

Chemical resistance of polycarbonate and nylon bowl

Type	Chemical name	Application examples	Material	
			Polycarbonate	Nylon
Acid	Hydrochloric acid Sulfuric acid Phosphoric acid Chromic acid	Acid washing liquid for metals	△	×
Alkaline	Sodium hydroxide (Caustic soda) Potash Calcium hydroxide (Slack lime) Ammonia water Carbotane of soda	Degreasing of metals Industrial salts Water-soluble cutting oil	×	○
Inorganic salts	Sodium sulfide Potassium nitrate Sulfate of soda	-	×	△
Chlorine solvents	Carbon tetrachloride Chloroform Ethylene chloride Methylene chloride	Cleaning liquid for metals Printing ink Dilution	×	△
Aromatic series	Benzene Toluene Paint thinner	Coatings Dry cleaning	×	△
Ketone	Acetone Methyl ethyl ketone Cyclohexane	Photographic film Dry cleaning Textile industries	×	×
Alcohol	Ethyl alcohol IPA Methyl alcohol	Antifreeze Adhesives	△	×
Oil	Gasoline Kerosene	-	×	○
Ester	Phthalic acid dimethyl Phthalic acid diethyl Acetic acid	Synthetic oil Anti-rust additives	×	○
Ether	Methyl ether Ethyl ether	Brake oil additives	×	○
Amino	Methyl amino	Cutting oil Brake oil additives Rubber accelerator	×	×
Others	Thread-lock fluid Sea water Leak tester	-	×	△

○: Essentially safe. △: Some effects may occur. ×: Effects will occur.

Note1) When the above factors are present or there is some doubt, use a metal bowl for safety.

- (3) Avoid the application where charge and discharge of pressure to/from a standard bowl is switched frequently. This may damage the bowl. A metal bowl is recommended in these cases.
- (4) Shield from ultra violet light and radiation with protective cover.

**Caution**

- (1) The 25A-series is a series that does not use copper (Cu) or zinc (Zn) and limits the use of materials containing these as the main components.

Selection**Warning**

- (1) Grease used on the internal sliding parts and seals may flow to the outlet side.

Installation**Warning**

- (1) Do not drop or apply impact during transportation or installation. It will cause damage to the product and result in operation failure.
- (2) Do not install in areas of high humidity or high temperature. Operation outside of the product specification range may cause damage to the product or operation failure, or shorten the product life.
- (3) Connect the product ensuring the direction of "1"(IN) and "2"(OUT) for air direction and indicated arrow. Incorrect connections may cause malfunction.
- (4) Install with adequate space for maintenance beneath the product. Refer to the section [12. Dimensions] for necessary space.
- (5) Install vertically so that outlet of drain is downward. It cannot be used in horizontal or upward direction as it may cause operation failure.

Piping**Warning**

- (1) Before piping is connected, it should be thoroughly blown out with air (flushing) or washed to remove chips, cutting oil and solid foreign material from inside the pipe. Contamination of piping may cause damage or malfunction.
- (2) When screwing together pipes and fittings, etc., be certain that chips from the pipe threads and sealant do not get inside the pipe. When a sealant tape is used, leave 1 thread ridge exposed at the end of the threads.
- (3) Connect piping/fittings using the recommended torque while holding the female thread side tightly. Insufficient tightening torque leads to cause of loosening or sealing failure, and excessive tightening torque leads to cause of breakage of screws. Tightening without holding female thread applies an excessive force to the bracket directly, leading to breakage.

Recommended tightening torque						Unit: N m
Thread size	1/8	1/4	3/8	1/2	3/4	1
Torque	3 to 5	8 to 12	15 to 20	20 to 25	28 to 30	36 to 38

- (4) Before using an SMC fitting and S coupler, please refer to "Tightening the threaded portion of the connection thread" of the Fittings & Tubing Precautions.
- (5) Do not apply torsion or bending moment other than the weight of the product itself. External piping needs to be supported separately as it may cause breakage. Non-flexible piping like steel tube is susceptible to excessive moment load or vibration. Insert flexible tubes to prevent this.

**Caution**

- (1) Usage of nylon tubing and polyurethane tubing in environments with a low dew point may affect dew points of ambient air and inside of piping. Use fluoropolymer tubing (TL series) or stainless steel tubing (Supply it on your own) in environments with a low dew point.

Air Source

Warning

- (1) Use clean air. Do not use compressed air containing chemicals, organic solvent, synthetic oil or corrosive gas as it may be cause of breakage of components or operation failure.
- (2) Air containing too much moisture may cause malfunction. Install an air drier or aftercooler before the air filter.

Maintenance

Warning

- (1) Release the pressure in the product to the atmosphere when replacing parts or removing piping.
- (2) Maintenance and checks should be done by following the procedure in this operation manual. Incorrect handling of the product may cause breakage or operation failure of the equipment or device.
- (3) Perform periodical check to find cracks, flaws or other deterioration on resin bowl.
If any of these appear, replace with a new or metal bowl. Otherwise, breakage may occur. Investigate and/or review the operating conditions if necessary.
- (4) Check for dirt in resin bowl periodically. If any dirt is seen, replace with new bowl. If removing dirt by washing the resin bowl, never use washing material other than neutral detergent. Otherwise, the bowl is damaged.
- (5) Open and close the drain cock manually. The use of tools can result in damage to the product.
- (6) Replace the element every 2 years or when the pressure drop at the output pressure from initial operation becomes 0.1 MPa, whichever comes first, to prevent damage to the element.
- (7) Discharge drain in the bowl before it reaches the element assembly. Refer to the section [7. Operation and Adjustment] for discharging of drain.

Caution

- (1) Check the element periodically and replace it with a new one if necessary. If it is found that outlet pressure drops lower than the normal condition or the flow is restricted during operation, check the condition of the element.

2. Application

This product aims at eliminating excess saturated water and solid foreign matter in the air line.

3. Standard Specifications

Model	25A-AF20-D	25A-AF30-D	25A-AF40-D	25A-AF40-06-D	25A-AF50-D	25A-AF60-D
Port size	1/8, 1/4	1/4, 3/8	1/4, 3/8, 1/2	3/4	3/4, 1	1
Fluid	Air					
Ambient and fluid temperature	-5 to 60 ° C (with no freezing)					
Proof pressure	1.5 MPa					
Max. operating pressure	1.0 MPa					
Filtration rating	5µm					
Compressed air quality class ^{Note 1)}	ISO8573-1:2010 [6:8:4]					
Drain capacity	8 cm ³	25 cm ³	45 cm ³			
Bowl material	Polycarbonate					
Bowl guard	Semi-standard (Steel)		Standard (Polycarbonate)			
Weight	0.09 kg	0.17 kg	0.35 kg	0.39 kg	0.85 kg	0.92 kg

Note 1) Based on ISO8573-1:2010 Compressed air - Part1: Contaminants and purity classes.

The compressed air quality class on the inlet side is [7:9:4].

4. How to Order

25A - AF **1** - **2** **3** **4** - **5** - D

Series compatible with secondary batteries

*For detailed specifications, please refer to the series catalog for secondary batteries.

		Symbol	Description	1						
				Body size						
				20	30	40	50	60		
2	Thread type	Nil	Rc	●	●	●	●	●		
		N	NPT	●	●	●	●	●		
		F	G	●	●	●	●	●		
3	Port size	01	1/8	●	-	-	-	-		
		02	1/4	●	●	●	-	-		
		03	3/8	-	●	●	-	-		
		04	1/2	-	-	●	-	-		
		06	3/4	-	-	●	●	-		
		10	1	-	-	-	●	●		
4	Option	a	Mounting	Nil	Without mounting option	●	●	●	●	●
				B	With bracket	●	●	●	●	●
5	Semi-standard	b	Flow direction	Nil	Flow direction: Left to right	●	●	●	●	●
				R	Flow direction: Right to left	●	●	●	●	●
	c	Pressure unit Temp. unit	Nil	Pressure unit: MPa Temp. unit: °C	●	●	●	●	●	
			Z	Pressure unit: psi Temp. unit: °F	○ Note 2)	○ Note 2)	○ Note 2)	○ Note 2)	○ Note 2)	

Note 1) **4**Option and **5**Semi-standard: Select one each for a to c.

Note 2) ○: For NPT thread type only.

5. Structural Drawing, Option and Replacement Parts

Structural drawing / Option / Replacement parts

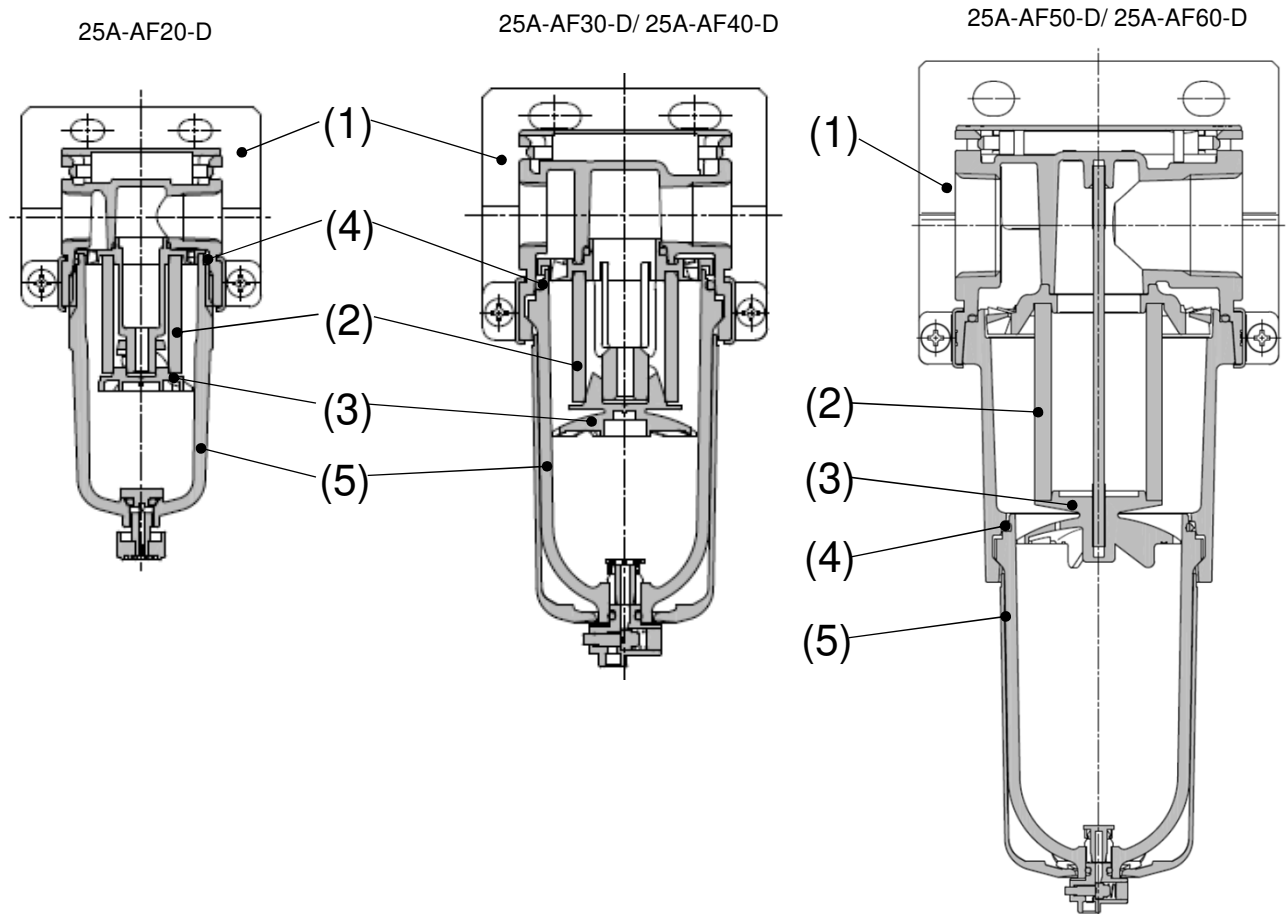

Option

No.	Part name	Part No.					
		25A-AF20-D	25A-AF30-D	25A-AF40-D	25A-AF40-06-D	25A-AF50-D	25A-AF60-D
(1)	Bracket assembly ^{Note 2)}	25A-AF24P-070AS	25A-AF34P-070AS	25A-AF44P-070AS	25A-AF49P-070AS	25A-AF54P-070AS	

Note 1) The number in the table and structural drawing is consistent with the number in [10. How to Replace the Components] and [11. Disassembly Drawing].

Note 2) Assembly of 2 types of bracket and 2 set screws.

Replacement Parts

No.	Part name	Part No.					
		25A-AF20-D	25A-AF30-D	25A-AF40-D	25A-AF40-06-D	25A-AF50-D	25A-AF60-D
(2)	Element	AF20P-060S	AF30P-060S	AF40P-060S		AF50P-060S	AF60P-060S
(3)	Baffle	AF24P-040S	AF34P-040S	AF44P-040S		AF54P-040S	AF64P-040S
(4)	Bowl seal	25A-C2SFP-260S	25A-C32FP-260S	25A-C42FP-260S			
(5)	Bowl assembly	Refer to the section [6. Bowl Assembly Specifications]					

Note 1) The number in the table and structural drawing is consistent with the number in [10. How to Replace the Components] and [11. Disassembly Drawing].

6. Bowl Assembly Specifications

6-1. Bowl assembly for 25A-AF20-D

Option symbol	—	
Semi-standard symbol	—	
Appearance and part No.	Semi-standard: — (Standard)	
	Piping port thread type	(5) Part No.
	Rc	25A-C2SF-D
	G	25A-C2SF(-Z)-D
	NPT	25A-C2SF(-Z)-D

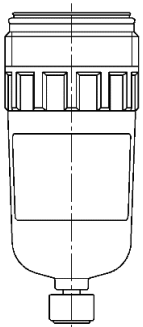

6-2. Bowl assembly for 25A-AF30-D

Option symbol	—	
Semi-standard symbol	—	
Appearance and part No.	Semi-standard: — (Standard)	
	Piping port thread type	(5) Part No.
	Rc	25A-C3SF-D
	G	25A-C3SF(-Z)-D
	NPT	25A-C3SF(-Z)-D

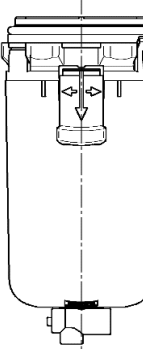

6-3. Bowl assembly for 25A-AF40, 50, 60-D

Option symbol	—	
Semi-standard symbol	—	
Appearance and part No.	Semi-standard: — (Standard)	
	Piping port thread type	(5) Part No.
	Rc	25A-C4SF-D
	G	25A-C4SF(-Z)-D
	NPT	25A-C4SF(-Z)-D

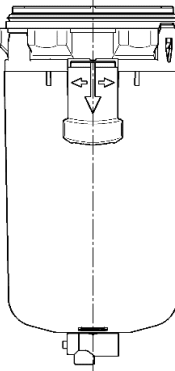

Note 1) Part No. (5) includes Bowl seal (4). Refer to the section [11. Disassembly Drawing]

Note 2) "Z" in Part No. (5) indicates standard specifications. The pressure unit: psi. The temperature unit: °F.

Note 3) Refer to the section [4. How to Order] for option and semi-standard symbols.

7. Assembly of Optional Parts

Bracket

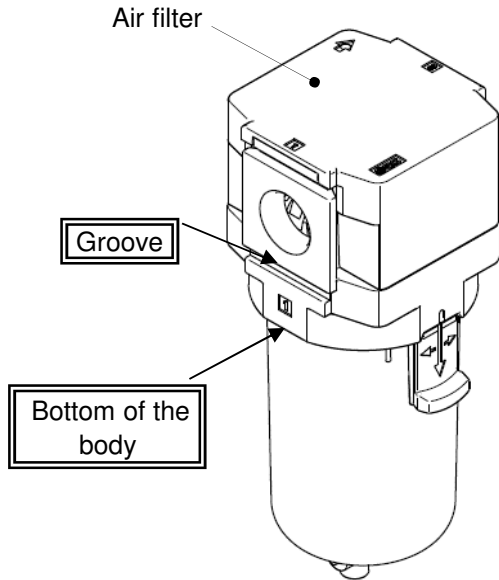

1) Mounting of bracket A

Insert bracket A from the front of the air filter so that the fingers of the bracket A hold the air filter at the groove and the bottom of the body.

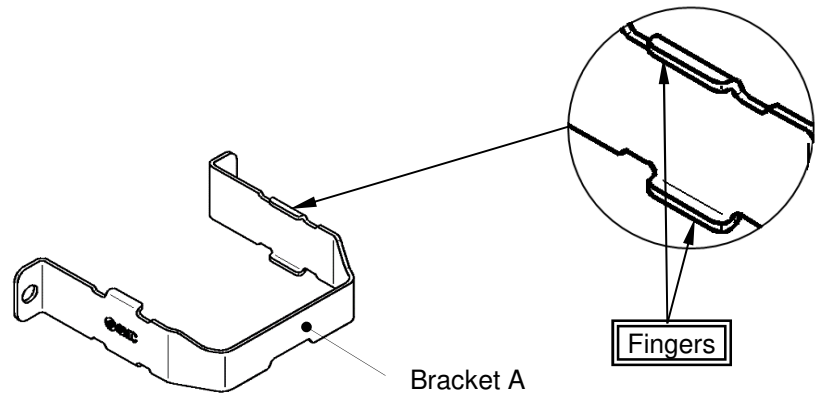

2) Mounting of bracket B

Fix the bracket B with the set screw (2 pcs.) included in the package. Refer to the table below for the tightening torque.

Bracket B

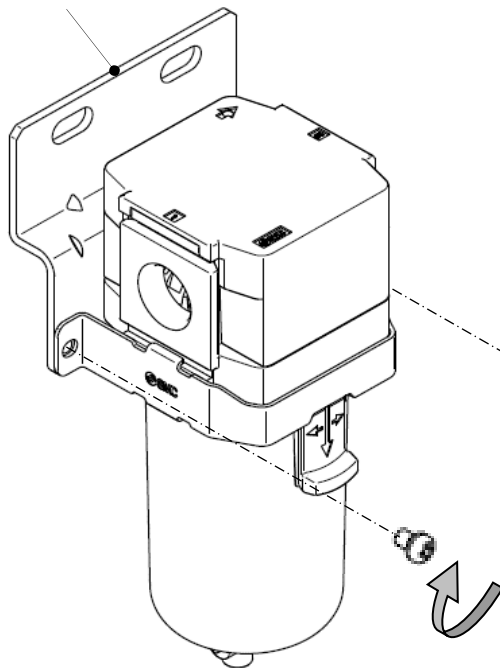

Model	Tool	Tightening torque
25A-AF20-D	Phillips screwdriver	0.75+/-0.2 N m
25A-AF30-D		
25A-AF40-D		1.5+/-0.2 N m
25A-AF50-D		
25A-AF60-D		

8. Operation and Adjustment

Discharge from the product with drain cock

- Pressurize the inside of the air filter when discharging drain. Drain will not be discharged properly if not pressurized.
- Drain discharge mechanism is different depending on the bowl assembly. Check the bowl assembly and discharge the drain following the method below.
Rotation type: After discharging the drain, tighten the drain cock to the opposite direction by hand until the seal inside seals correctly. Use of a tool can damage the product.

25A-AF20-D: Drain cock (rotation type)

25A-AF30-D / 25A-AF40-D / 25A-AF50-D / 25-AF60-D
: Drain cock (push type)

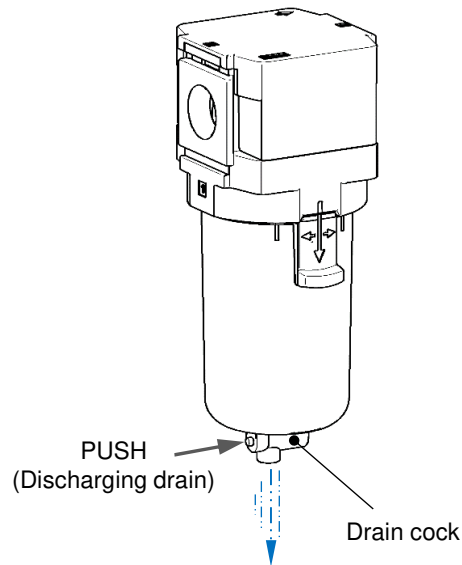
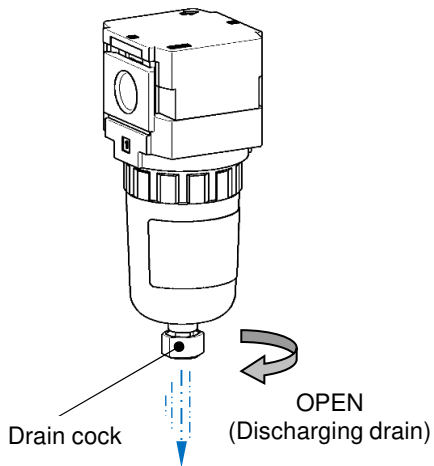

9. Trouble Shooting

Refer to the sections [8. Operation and Adjustment], [10. How to Replace the Components] and [11. Disassembly Drawing].

Trouble		Possible cause	Countermeasure	Page for reference
Category	Failure			
Flow rate	As pressure drop is large, fluid does not flow.	1. Clog of the element.	Replace the element.	P14-19
Air leakage	Air leakage from between the body and the bowl.	1. The bowl seal is damaged.	Replace the bowl seal. Grease up before replacing the bowl seal. <small>Note)</small>	P14-16
	Air leakage from the bowl.	1. The bowl is damaged.	Replace the bowl assembly. (If the solvent is considered to be harmful, replacement to a metal bowl is recommended.)	P14-16
	Air leakage from the drain cock.	1. Foreign matter caught in the valve of the drain cock.	Open the drain cock for a few seconds for blowing.	P12
2. Seating part of the drain cock is damaged.		Replace the bowl assembly.	P14-16	
Operability	Drain is not discharging when the drain cock opens.	1. Blockage of outlet of the drain cock due to solid foreign matter etc.	Replace the bowl assembly.	P14-16
	Too much drain comes from the piping of outlet side.	1. Drain level reaches the baffle.	Open the drain cock for discharging and replace the element.	P12 P14-19

Note) Special grease is used for 25A- series products.

Grease pack for maintenance "GR-D-###" is recommended for use. (See table 1)

Please follow coating amount per unit for the amount used. (See table 2)

Table 1. Grease pack No.

No.	Mass(g)
GR-D-005	5
GR-D-010	10
GR-D-100	100

Table 2. Coating amount per unit

Model	Mass(g)
25A-AF20-D	0.1
25A-AF30-D	0.15
25A-AF40-D	0.2
25A-AF50-D	0.25
25A-AF60-D	0.25

10. How to Replace the Components





Warning

Before replacement, make sure that no pressure remains in the product.

After replacement, confirm that the product satisfies specific functions and no external leakage occurs before operating it.

10-1. Bowl Assembly Replacement

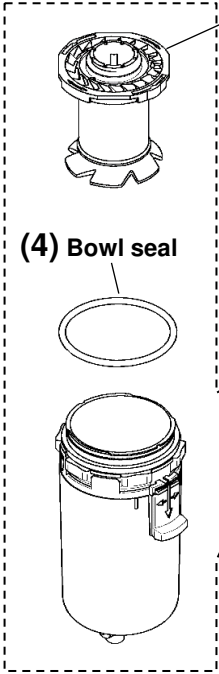
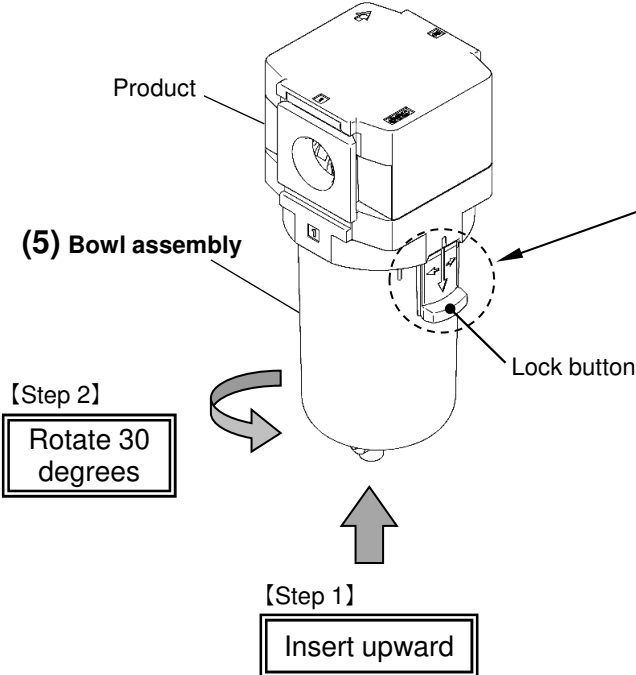
Applicable model	Work category	Procedure	Tool	Criteria
25A-AF20-D	Disassembly	<p>1) Remove the bowl assembly from the product. If the bowl assembly is tightened too much to be removed, use a hook spanner until it can be loosened by hand.</p>	Spanner specified for SMC Product No.: 1129129	-
	Work category	Procedure	Tool	Criteria
	Assembly	<p>1) Screw the bowl assembly into the product. Tighten it referring to the specified torque.</p>	-	Reference tightening torque: 2.1 N m

Applicable model	Work category	Procedure	Tool	Criteria
25A-AF30-D 25A-AF40-D	Disassembly	<p>1) Remove the bowl assembly from the product. While the lock button is held down, rotate the bowl assembly by approx. 30 degrees so that the mating marks of the body and bowl assembly meet each other. Then remove the bowl assembly by pulling it downward.</p>	-	-
<div style="display: flex; justify-content: space-between;"> <div style="width: 30%;">  <p>(4) Bowl seal</p> <p>(5) Bowl assembly</p> </div> <div style="width: 65%;"> <p>Element assembly Replacement of the bowl seal will be easier when the element assembly is removed first. Refer to the section [10-2. Element Replacement]</p> <p>Product</p> <p>Align the mating marks Mating mark of the body</p> <p>Mating mark of the bowl assembly</p> <p>Lock button</p> <p>[Step 1] Rotate 30 degrees</p> <p>[Step 2] Pull downward</p> </div> </div>				
Work category	Procedure	Tool	Criteria	
Assembly	<p>1) Mount the bowl assembly to the product and rotate the bowl assembly until the lock button is locked in position as shown in the figure below.</p>	-	-	
<div style="display: flex; justify-content: space-between;"> <div style="width: 60%;">  <p>(5) Bowl assembly</p> <p>Product</p> <p>Lock button</p> <p>[Step 2] Rotate 30 degrees</p> <p>[Step 1] Insert upward</p> </div> <div style="width: 35%;">  <p>Caution</p> <p>Make sure that the lock button is locked to the flute of the product before pressurising it.</p> </div> </div>				

Applicable model	Work category	Procedure	Tool	Criteria
25-AF50-D 25-AF60-D	Disassembly	<p>1) Remove the bowl assembly from the product. While the lock button is held down, rotate the bowl assembly by approx. 30 degrees so that the mating marks of the body and bowl assembly meet each other. Then remove the bowl assembly by pulling it downward.</p>	-	-
<p>Product</p> <p>Align the mating marks Mating mark of the housing</p> <p>(4) Bowl seal</p> <p>(5) Bowl assembly</p> <p>Mating mark of the bowl assembly</p> <p>Lock button</p> <p>[Step 1] Rotate 30 degrees</p> <p>[Step 2] Pull downward</p>				
Work category	Procedure	Tool	Criteria	
Assembly	<p>1) Mount the bowl assembly to the product and rotate the bowl assembly until the lock button is locked in position as shown in the figure below.</p>	-	-	
<p>Product</p> <p>(5) Bowl assembly</p> <p>Lock button</p> <p>[Step 2] Rotate 30 degrees</p> <p>[Step 1] Insert upward</p> <p>Caution Make sure that the lock button is locked to the flute of the product before pressurising it.</p>				

10-2. Element Replacement

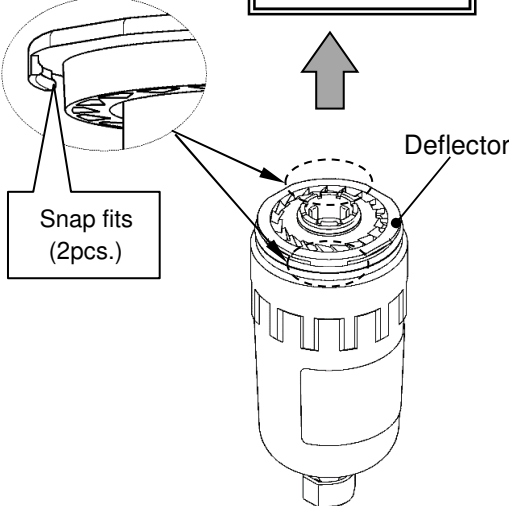
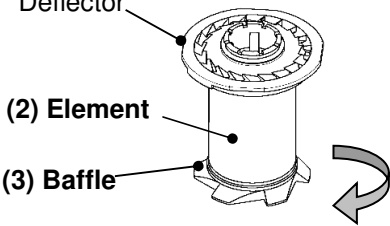
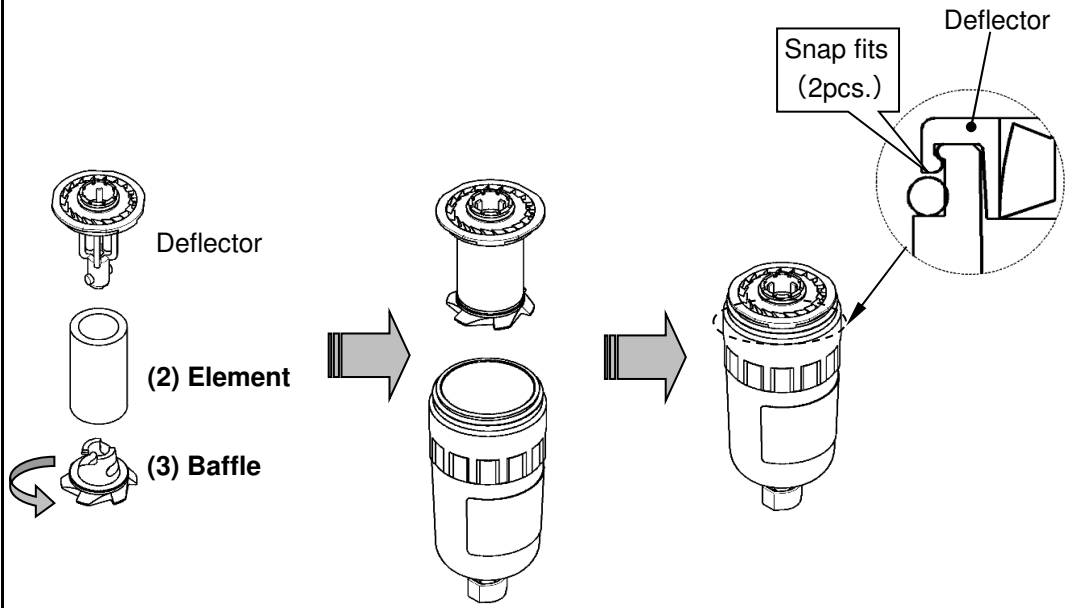
Applicable model	Work category	Procedure	Tool	Criteria
25A-AF20-D	Disassembly	<p>1) First remove the bowl assembly referring to the section [9-1. Bowl Assembly Replacement], then remove the snap fits (2 pcs.) of the deflector and pull upward to remove the element assembly. Rotate the baffle in the arrow direction to remove the element from the element assembly.</p>	-	-
		<div style="display: flex; justify-content: space-around; align-items: center;"> <div style="text-align: center;"> <p>【Step 1】</p> <div style="border: 1px solid black; padding: 2px;">Pull upward</div>  </div> <div style="text-align: center;"> <p>【Step 2】</p> <div style="border: 1px solid black; padding: 2px;">Rotate the baffle.</div>  </div> </div>		
	Work category	Procedure	Tool	Criteria
	Assembly	<p>1) Mount the element to the deflector and rotate the baffle in the arrow direction to mount the element to the baffle. Once the element and baffle are mounted, press the deflector downward until the snap fits (2 pcs.) are engaged with the bowl assembly. Mount the bowl assembly referring to section [10-1. Bowl Assembly Replacement].</p>	-	-
				

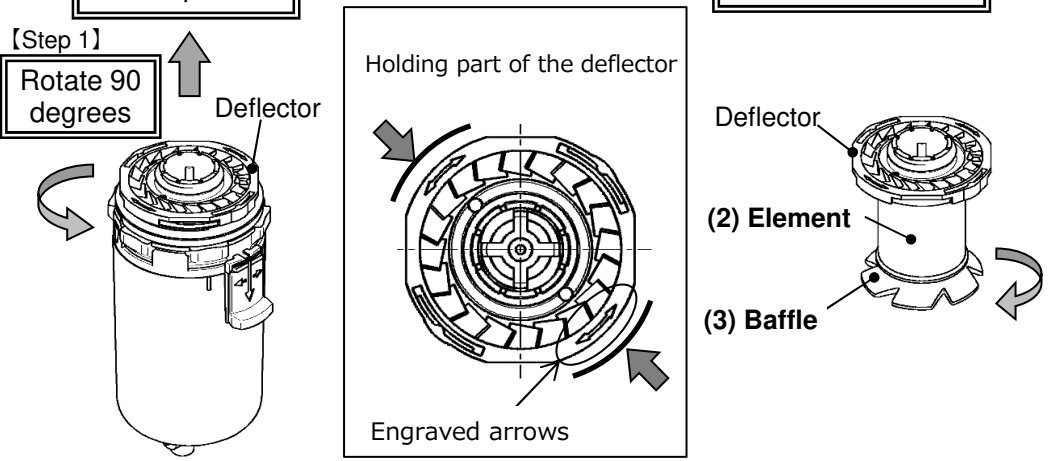
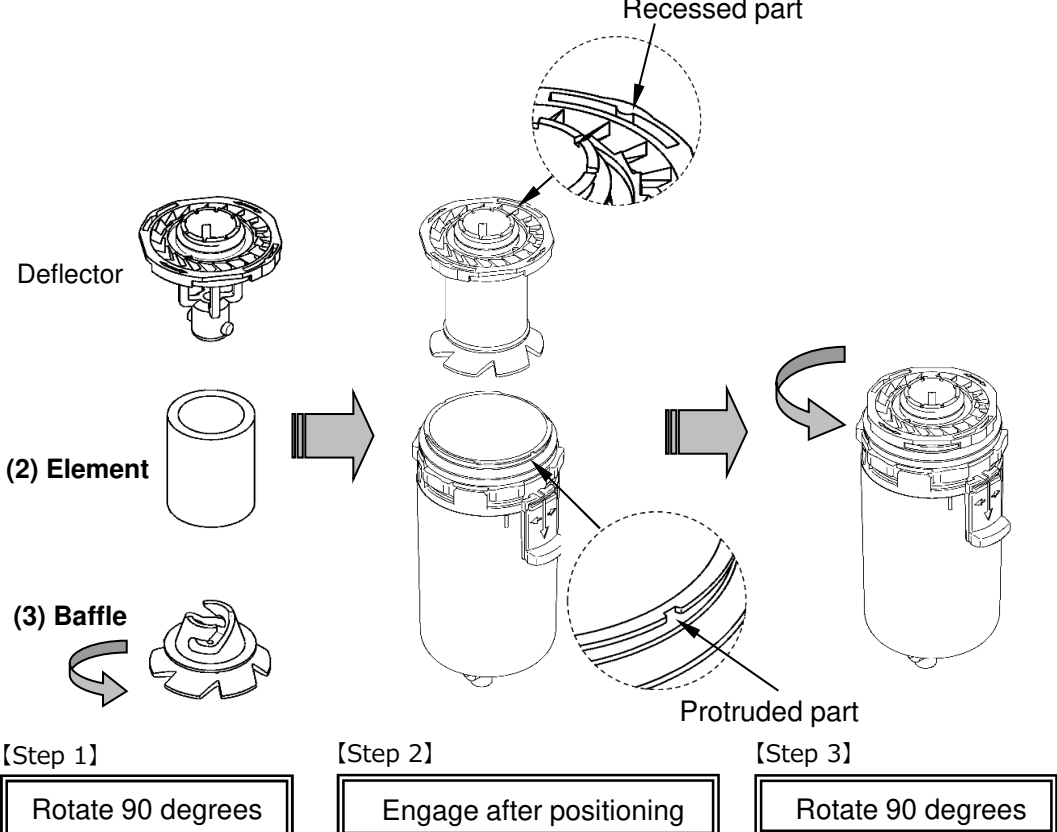
Applicable model	Work category	Procedure	Tool	Criteria
25A-AF30-D 25A-AF40-D	Disassembly	<p>1) Remove the bowl assembly referring to the section [9-1. Bowl Assembly Replacement]. With the bowl assembly removed, rotate the deflector 90 degrees while holding the holding parts and remove the element assembly.</p>	-	-
<div style="display: flex; justify-content: space-around;"> <div style="text-align: center;"> <p>【Step 2】</p> <div style="border: 1px solid black; padding: 2px;">Pull upward</div> </div> <div style="text-align: center;"> <p>【Step 3】</p> <div style="border: 1px solid black; padding: 2px;">Rotate 90 degrees</div> </div> </div> 				
Work category	Procedure	Tool	Criteria	
Assembly	<p>1) Mount the element to the deflector and rotate the baffle in the arrow direction to mount the element to the baffle. Then insert the element assembly into the bowl assembly and rotate in either direction so that the protruded part of the element assembly engages with the recessed part of the bowl assembly. Mount the bowl assembly referring to the section [10-1. Bowl Assembly Replacement].</p>	-	-	
 <div style="display: flex; justify-content: space-around; margin-top: 10px;"> <div style="text-align: center;"> <p>【Step 1】</p> <div style="border: 1px solid black; padding: 2px;">Rotate 90 degrees</div> </div> <div style="text-align: center;"> <p>【Step 2】</p> <div style="border: 1px solid black; padding: 2px;">Engage after positioning</div> </div> <div style="text-align: center;"> <p>【Step 3】</p> <div style="border: 1px solid black; padding: 2px;">Rotate 90 degrees</div> </div> </div>				

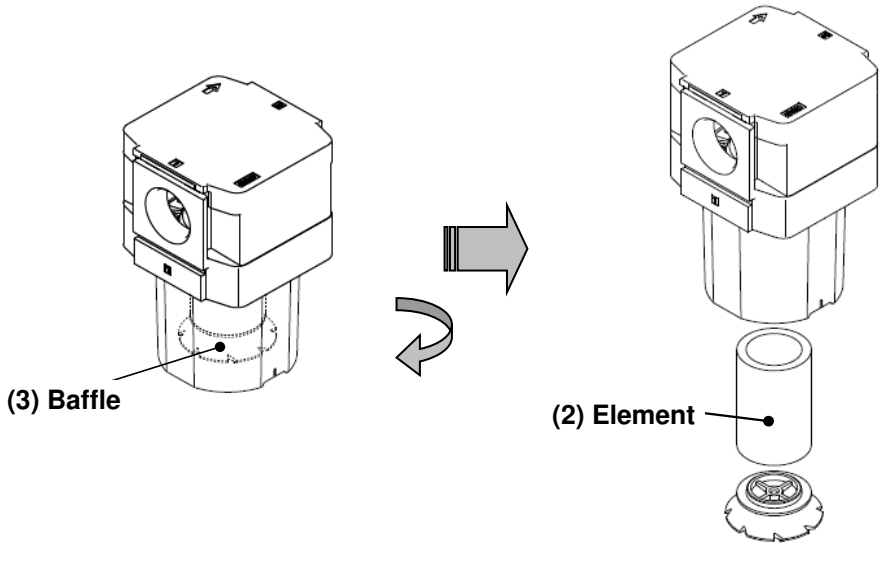
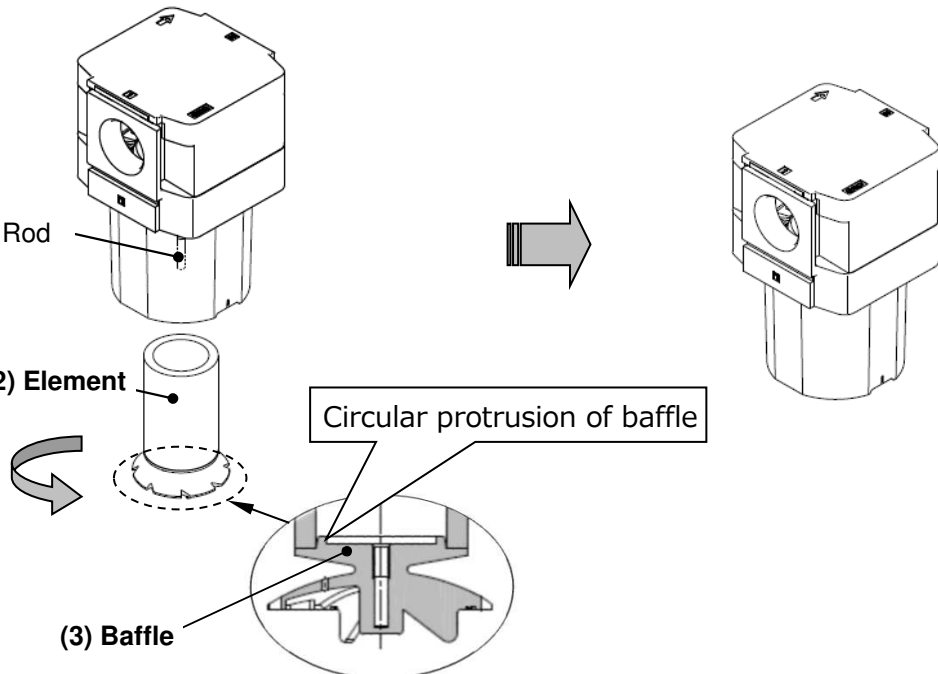
Applicable model	Work category	Step	Tool	Criteria
25A-AF50-D 25A-AF60-D	Disassembly	1) Remove the bowl assembly referring to the section [10-1. Bowl Assembly Replacement]. When the bowl assembly is removed, rotate the baffle to the left to remove the element.	-	-
				
	Assembly	1) Assemble the element and baffle. Then, assemble the baffle to the rod by rotating it to the right by hand. Rotate the baffle until the element is set without play. Then, rotate the baffle another 1/2 turn to the right. Refer to the tightening torque in the Criteria when tightening by hand. Mount the bowl assembly referring to the section [10-1. Bowl Assembly Replacement].	-	Reference tightening torque: 1.8 N m
				

11. Disassembly Drawing

25A-AF20-D

25A-AF30-D,25A-AF40-

25A-AF50-D,25A-AF60-D

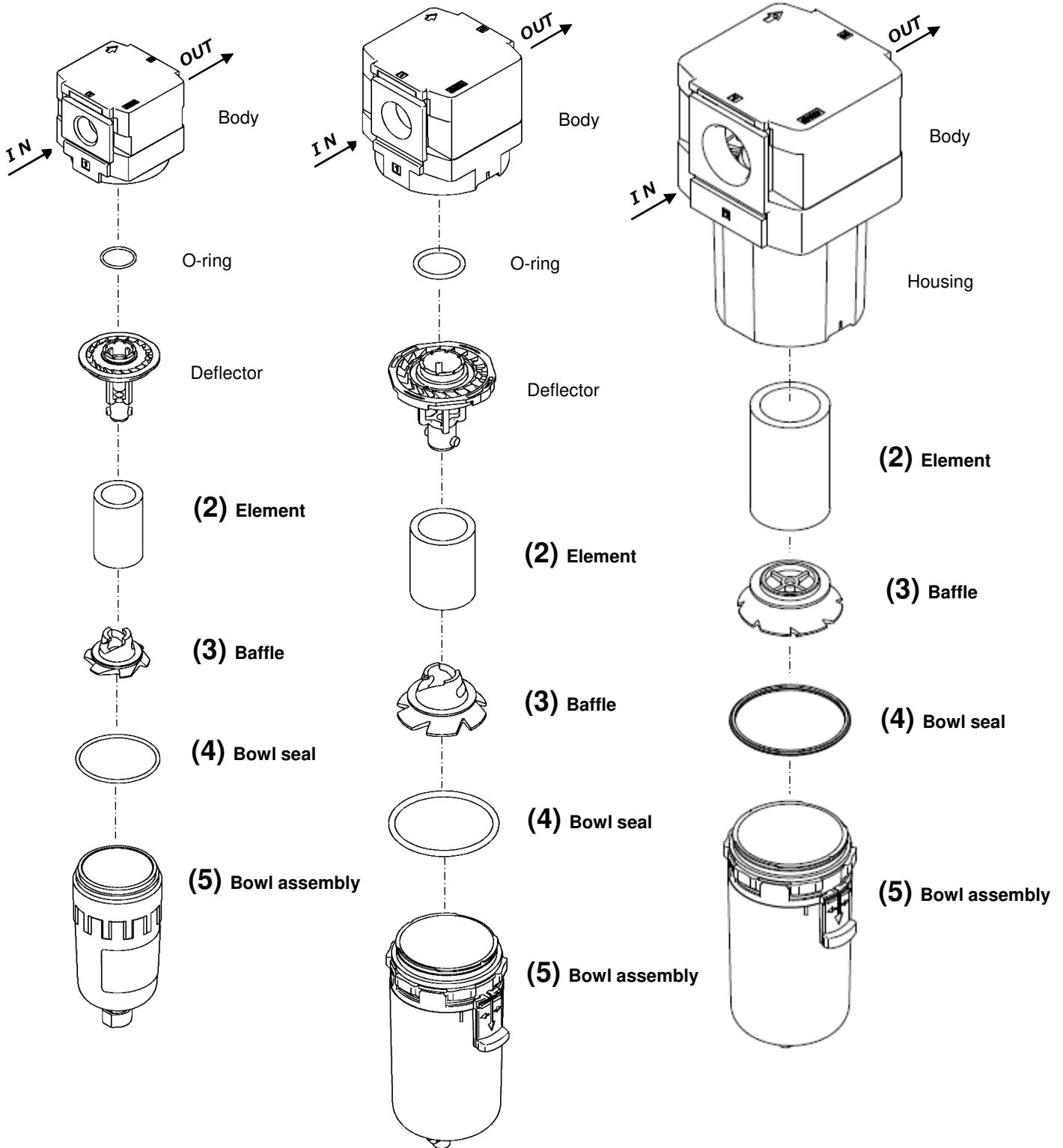

12. Dimensions

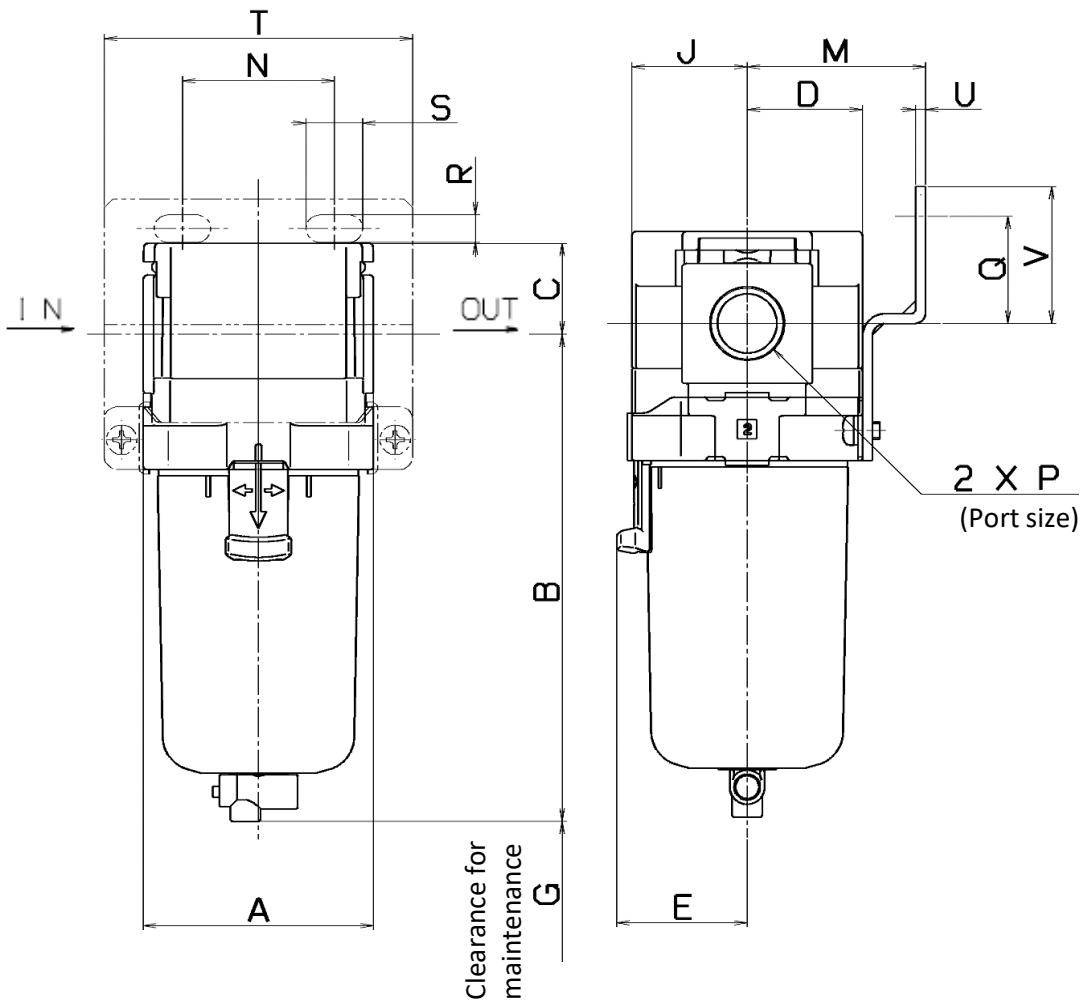

Model	Standard specifications								Optional specifications							
									Bracket mount							
	P	A	B	C	D	E	G	J	M	N	Q	R	S	T	U	V
25A-AF20-D	1/8, 1/4	40	87.6	17.5	21	-	25	21	30	27	22	5.4	8.4	60	2.3	28
25A-AF30-D	1/4, 3/8	53	115.4	21.5	26.5	30	35	26.5	41	35	25	6.5	13	71	2.3	32
25A-AF40-D	1/4, 3/8, 1/2	70	147.1	25.5	35.5	38.4	40	35.5	50	52	30	8.5	12.5	88	2.3	39
25A-AF40-06-D	3/4	75	149.1	27	35.5	38.4	40	35.5	50	52	34	8.5	12.5	88	2.3	43
25A-AF50-D	3/4, 1	90	220.1	32	45	-	30	45	70	66	40.5	11	13	113	3.2	52.5
25A-AF60-D	1	95	234.1	32	45	-	30	45	70	66	40.5	11	13	113	3.2	52.5

Revision history

SMC Corporation

4-14-1, Sotokanda, Chiyoda-ku, Tokyo 101-0021 JAPAN

Tel: + 81 3 5207 8249 Fax: +81 3 5298 5362

URL <https://www.smcworld.com>