

G thread Adapter Set

Thermo chiller

HRS Series / HRS-EP014

Introduction

Thank you for purchasing SMC's HRS Thermo chiller. This [G thread Adapter Set] includes the adapters for the piping thread that are used for the thermo-chiller HRS series. Please confirm the following procedure before handling.

Safety caution

- This work should be done by a person who has enough knowledge of general machineries. Check the safety before the work.
- Read and understand the Thermo chiller's operation manual before the work.
- Do not supply power during the work. Be sure to check that the power supply is shut off.
- Work on before supplying circulating fluid or discharge all Circulating fluid from the Thermo chiller.

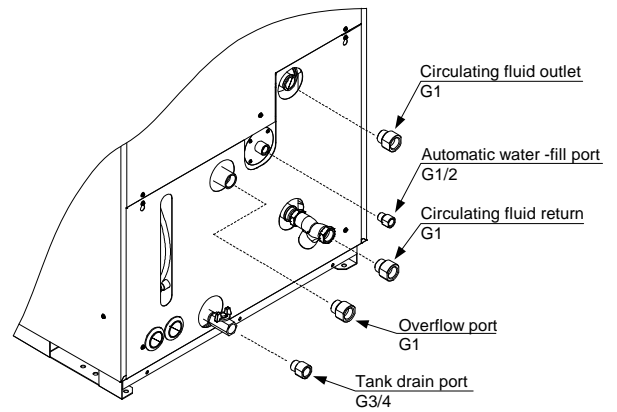



- 7) Operate the Thermo chiller and check that there is no fluid leakage after the sealant hardening.

1. Parts and Accessories

- This [G thread Adapter Set] includes the following parts. Please check that all required parts are included.

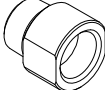
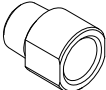
Parts List

- | | |
|-----------------------------------------------------------------------------------------------------------------------------------------------------------------|-----------------------------------------------------------------------------------------------------------------------------------------------------------------|
| <p>①</p>  <p>Manual(This manual)</p> | <p>②</p>  <p>Rc-G Adapter (1 inch)
(Material: Stainless)
3 pcs.</p> |
| <p>③</p>  <p>Rc-G Adapter (3/4 inch)
(Material: Stainless)
1 pc.</p> | <p>④</p>  <p>Rc-G Adapter (1/2 inch)
(Material: Stainless)
1 pc.</p> |

2. Mounting

- 1) Check that there is no dust and foreign material in the connection parts of the Thermo chiller.
- 2) Use seal tape or sealant for the adapters as sealant material.
- 3) Fasten the [Rc-G Adapter (1 inch)] into the outlet port, return port of the circulating fluid and overflow port. (recommended torque: 36 to 38 N·m)
- 4) Fasten the [Rc-G Adapter (1/2 inch)] into the automatic water-fill port. (recommended torque: 28 to 30N·m)
- 5) Fasten the [Rc-G Adapter (3/4 inch)] into the tank drain port. (recommended torque: 28 to 30N·m)
- 6) Sealing material is not attached. Please purchase separately (SMC part no: HRG-S0214).

When using sealant, apply it around the screw part of [Rc-G Adapter] leaving a thread from the end. It will take approx. 2 hours to harden. Do not supply circulating fluid before hardening.