

---

# OPERATION MANUAL

---

PRODUCT NAME: FILTER REGULATOR WITH THE PRESSURE GAUGE BUILT-IN

MODEL:                   AWG20-(F,N)01 ~ (F,N)02(B,C,H)(G1,G2,G3,G4)(-1,2,6,C,J,N,Z)

AWG30-(F,N)02 ~ (F,N)03(B,C,D,H)(G1,G2,G3,G4)(-1,2,6,8,J,N,W,Z)

AWG40-(F,N)02 ~ (F,N)04(B,C,D,H)(G1,G2,G3,G4)(-1,2,6,8,J,N,W,Z)

---

---

---

---

---

---

---

---

---

---

- Read this operation manual carefully to understand before installation and operation.
- Pay extra attention on the clause concerning the safety.
- Keep this operation manual available whenever necessary.

# CONTENTS

	PAGE
1. PRECAUTIONS FOR SAFETY	1~4
2. APPLICATION	5
3. SPECIFICATIONS	5
4. HOW TO ORDER	5
5. TROUBLE SHOOTING	6
6. CONSTRUCTION/PARTS LIST	7
7. BOWL ASSEMBLY SPECIFICATIONS	8~10
8. HOW TO REPLACE	11~12
9. PROCEDURE OF THE PRESSURE GAUGE REPLACEMENT AND ANGLE ADJUSTMENT	13~14
10. DISASSEMBLY DRAWING	15~17
11. DIMENSIONS	18



CONTACT ADDRESS: SMC CORPORATION

1-16-4, SHINBASHI, MINATO-KU, TOKYO  
105-8659, JAPAN  
TEL: 03-3502-8271

## 1. PRECAUTIONS FOR SAFETY

Precautions shown here are to ensure the product is used correctly and safely, and to prevent hazard and damage inflicting upon people from occurring. These precautions are divided into three categories, "Caution", "Warning", and "Danger" to indicate the degree of possible hazard and damage, and urgency.

As all these are important for safety, never fail to follow them in addition of ISO 4414(※1), JIS B 8370(※2), and other safety regulations.

-  **Caution** : Possible harmful effects are expected to be on people and possible loss is expected only of objects when wrong operation occurred.
-  **Warning** : Possible loss or serious injury of people is expected when wrong operation occurred.
-  **Danger** : Imminent danger that possible loss or serious injury of people is expected without evacuation.

※1) ISO 4414 Pneumatic fluid power—General rules relating to systems.

※2) JIS B 8370 Common regulations for pneumatic systems.

### **WARNING**

- ① **Suitability of pneumatic equipment should be determined by a designer of the pneumatic system or a person who prescribes its specifications.**

Since the product shown here is used in various operating conditions, its suitability to a system should be determined by the pneumatic system designer or the person prescribes its specifications based on necessary analysis and tests. The person who determined the suitability of the system is responsible for the performance at a certain point of time and safety assurance of this system.

- ② **Equipment should be handled by those who have sufficient knowledge and experience**  
Compressed air fluid could be hazardous if it is handled incorrectly. Assembly, operation and maintenance of machinery and equipment for which pneumatic apparatuses are used should be performed by those who have sufficient knowledge and experience.
- ③ **Never handle the machinery or equipment, or never take out the apparatus until safety is confirmed**
  - a. Check and maintenance of machinery or equipment should be performed after it is confirmed that dropping or uncontrollable running prevention measures are taken for the equipment on which the product is mounted.
  - b. Apparatuses should be taken out after it is confirmed equipment corresponding to air supply, that is an energy source, should be turned off; and compressed air in the system should be exhausted.
  - c. Re-starting of machinery or equipment should be done with ample care after it is confirmed that prevention measures for sudden movement are taken.
- ④ **When the product is used in the following conditions or environment, considerations for safety measures should be given along with consultation to our company**
  - a. Outdoor usage, or usage in conditions or environment outside of the specifications indicated.
  - b. Usage for nuclear power, railroad, air navigation, vehicle, medical equipment, appliances contacting food and beverage, entertainment apparatuses, emergency shutdown circuits, clutch/break circuits for pressing, and safety devices.
  - c. Usage for applications which especially require safety because considerable effects to people and properties are expected.

## Precautions for design



### WARNING

- ① External parts including the bonnet, handle, cover are made of resin. Organic solvents including synthetic fluid, chemicals including acetone, alcohol, ethylene chloride, sulphuric acid, nitrate, hydrochloric acid, cutting oil, kerosene, gasoline, lock material of screw are harmful. Don't use the regulator where containing those.
- ② Avoid the application where charge and discharge of pressure to standard bowl is switched frequently. The bowl may be broken. For this kind of application, the metal bowl is recommended.
- ③ Consult SMC if no leakage is allowed due to the environment, or operating fluid is not air
- ④ Protect from ultra violet ray and radiation heat by shield.
- ⑤ Safety device needs to be installed if output pressure exceeding set pressure lead to cause the breakage of outlet device and equipment or malfunction.



### CAUTION

- ① The use outside specifications is prohibited.
- ② Air consumption from release port is 0.1L/min(ANR) or less.
- ③ AD27 with auto drain may leak the drain pooled there during exhaust of pressure. (This leakage is allowed in their constructions and not failure.) Be sure to connect piping for drain.

## Selection



### WARNING

- ① Mineral grease used for internal sliding surface and packing may leak to the outlet. Please contact SMC if this is a problem.
- ② Residual pressure(outlet pressure) is not released even if releasing inlet pressure. Select the filter regulator with counter flow function. Without the function, residual pressure may not be eliminated.
- ③ Long absence of operation or operation with outlet circuit sealed or balance circuit may cause pressure fluctuation in outlet set pressure. Please consult SMC if this is a problem.
- ④ Set pressure of outlet pressure shall be 85% or less of inlet pressure. Pressure over 85% makes operation susceptible to flow and inlet pressure which lead to cause unstable operation.
- ⑤ Maximum set pressure range in the spec. has margin. Pressure set may be higher than the maximum value.
- ⑥ If regulator is used with circuit which require high exhaust sensitivity or set precision, please consult SMC.
- ⑦ N.O type auto drain should be used under the following requirements to avoid operating failure.  
Output of compressor: 0.75kW or more.  
Discharged flow rate: 100L/min (ANR) or more.  
If multiple auto drains are used, confirm used compressor has capacity over the result of multiplying the above capacity and the number of used auto drains.  
[For example, in case of two auto drain, the compressor need the capacity over 1.5kW [200L/min (ANR)].]
- ⑧ N.C. type auto drain should be used under the following requirements to avoid operating failure.  
Operating pressure: 0.1MPa at min. for AD27, 0.15MPa at min. for AD37 and 47.

## Installation



### CAUTION

- ① Connect the filter regulator ensuring the direction of "IN" and "OUT" for air direction or an arrow. Wrong connection lead to cause malfunction.
- ② Install vertically so that outlet of drain would turn downward. Use with the outlet of drain turned lateral or upward causes malfunction.
- ③ Keep the space for maintenance and operation on the top, bottom and front face. The required space is shown on 「11. Dimensions」 (P18).
- ④ Don't drop nor apply impact during transportation or installation. gauge. These lead to cause precision failure of pressure .
- ⑤ Don't install where highly humid or temperature is high. Or pressure gauge may malfunction.

## Adjustment



### WARNING

- ① Adjust the pressure ensuring inlet pressure and outlet pressure. Excessive rotation may cause internal parts.
- ② Operate the pressure adjusting handle manually. Tools may break the handle.



### CAUTION

- ① Check primary pressure before setting up.
- ② For the regulator with the pressure gauge, don't apply pressure over the maximum scale of the pressure gauge in order to protect the gauge.
- ③ Adjust pressure incrementally. Pressure may become lower than set pressure if adjusted by decreasing the value. Rotate the handle clockwise to raise the set pressure. Counterclockwise, reduce the pressure.
- ④ Outlet pressure may rise if eliminate the inlet pressure after pressure setting and supply pressure again. The pressure becomes close to the set pressure after air is consumed in outlet.
- ⑤ Outlet pressure might change if uses for a long time. Please confirm set pressure regularly.

## Piping



### WARNING

- ① Flash or clean piping before piping to eliminate swarf, cutting oil, solid foreign material. Remaining of these lead to cause malfunction.
- ② When screw in piping or fitting, avoid entering of chips and sealing materials from piping screws into the inside of equipment. Or malfunction is led to occur. When use sealing tapes, leave 1.5~2 threads of a screw and starts taping.
- ③ Hold the female screw side and screw in piping with recommended tightening torque. Insufficient tightening torque lead to cause loose piping or sealing failure. Excessive torque may lead to cause screw breakage. Tightening without holding female screw side applies excessive force to the piping bracket which lead to cause breakage.

Recommended torque unit: N·m

Screw	1/8	1/4	3/8	1/2
Torque	7~9	12~14	22~24	28~30

\*1: First, tighten it by hand, then give it an additional 1/6 turn with a wrench.

- ④ Don't apply any torsional moment, or bending moment except the weight of the regulator itself. External pipings need its support separately. Hard piping like steel tube is susceptible to excessive moment load or vibration. Insert the flexible tube to cancel the influence.
- ⑤ Drain guide is not equipped with valve function. Be sure to connect piping for drain. No piping for drain allows the drain and compressed air to exhaust freely. Also, the piping should be performed with drain guide held by spanner to prevent breakage of bowl.
- ⑥ The piping for drain from auto drain should be connected under the following requirements to avoid operating failure.  
AD27: I.D.  $\phi$  2.5 ( $\phi$  3/32") at min., Length 5m (200") at max.  
AD37, 47(N): I.D.  $\phi$  4 ( $\phi$  3/16") at min., Length 5m (200") at max.  
AD38, 48(N): I.D.  $\phi$  6.5 ( $\phi$  1/4") at min., Length 5m (200") at max.

## Air Source



### WARNING

- ① Use clean air. Compressed air containing chemicals, organic solvent, synthetic oil or corrosive gas may lead to cause breakage of parts or malfunction.
- ② Air containing much drain lead to cause malfunction. Install the air drier or the after-cooler before the filter regulator.

## Maintenance



### WARNING

- ① Maintenance or check should be done by following the procedure in the operation manual. Incorrect handling of the product may cause breakage or malfunction of the equipment or device.
- ② Perform periodical check to find crack, flaw or other deterioration on resin bowl. If any of them is seen, as malfunction is caused, replace with new bowl or metal bowl.
- ③ Check the dirt of resin bowl periodically. If any dirt is seen, replace with new bowl. And if removing off the dirt by washing instead of replacement, never use washing material other than neutral detergent. Otherwise, the bowl is damaged.
- ④ Replace the element before 2 years passed since purchase or pressure drop from initial outlet pressure reaches 0.1MPa. Or the element is broken.
- ⑤ Open and close drain cock manually. Open and close by a too may damage the drain cock.
- ⑥ Drain the bowl by opening drain cock before the drain level in the bowl reaches baffle.



### CAUTION

- ① For First-aid for setting failure or leakage, check the internal valve sliding surface or the valve seat before giving first-aid treatment.
- ② Check the element periodically and replace it with new one if necessary.  
If it is found that secondary pressure lowers or the flow is restricted, check the condition of element.
- ③ The manual exhaust for emergency case can be performed by counterclockwise rotation of the handle in AD27. (O←direction)  
For AD37, 38, 47 and 48, rotate the drain cock counterclockwise in that case.(O←direction)

## 2. APPLICATION

This instrument aims at , eliminating excess saturated water of the air line and solid foreign material,pressure controlling of air lines.

## 3. SPECIFICATIONS

Model	AWG20	AWG30	AWG40
Port size	1/8·1/4	1/4·3/8	1/4·3/8·1/2
Fluid	AIR		
Proof pressure	1. 5MPa		
Max. operating pressure	1. 0MPa		
Set pressure range	0. 05~0. 85MPa		
Relieving pressure	Set pressure plus 0.05MPa {When relieving flow is 0.1L/min(ANR) }		
Ambient and fluid temperature	-5~60°C(Should be no freezing)		
Filtration	5 μ m		
Drain capacity	8cm <sup>3</sup>	25cm <sup>3</sup>	45cm <sup>3</sup>
Construction	Reliving type		
Weight	0. 38kg	0. 51kg	0. 86kg
Note4) Bowl guard*	△	○	○

注1) ○: Combinable to standard △: Combinable to option

## 4. HOW TO ORDER

AWG 20 - 01 G1 -

**Body size**

20
30
40

**Thread**

NIL	Rc
Note1) N	NPT
Note2) F	G

Note1) Drain guide(Bore size):  
NPT 1/8(AWG20)NPT 1/4(AWG30,40)  
Note2) Drain guide(Bore size):  
G 1/8(AWG20)G 1/4(AWG30,40)

**Port size**

01	1/8
02	1/4
03	3/8
04	1/2

**Option**

Symbol	Description	Applicable model
Nil	—	—
Note4) 1	Setting pressure 0.02~0.2MPa	AWG20~40
2	Metal bowl	AWG20~40
6	Nylon bowl	AWG20~40
8	Metal bowl with sight glass	AWG30, 40
C	Bowl guard	AWG20
Note5) J	drain guide	AWG20~40
N	Non-relieving styie	AWG20~40
W	With drain cock and barb fitting (For nylon φ6×φ4)	AWG20~40
Note6) Z	Nameplate, Pressure gauge Unit: PSI·° F	AWG20~40

When specifying more than one option, indicate symbols numerically then alphabetically.  
Note4) Only the adjusting spring is different from the standard model. Max. outlet pressure is 0.2MPa or more and it might go up.  
Note5) Without valve function.  
Note6) Thread: NPT Z is applicable to only overseas because of new measure ment law in Japan(SI unit).

**Accessory ②**

Symbol	Description	Applicable model
Nil	—	—
H	Panel mounting(With set nut)	AWG20~40

**Accessory ①>Note3)**

Symbol	Description	Applicable model
Nil	—	—
B	With Bracket(With set nut)	AWG20~40
C	With float auto drain (N.C.)	AWG20~40
D	With float auto drain (N.O.)	AWG30, 40

Note3) Accessory is packed together and is not mounted.

### ●Drawing of pressure gauge mounting direction

Accessory	G1	G2	G3	G4
Mounting angle	0°	90°	180°	270°
Drawing of mounting angle				

## 5. TROUBLESHOOTING

Refer to 「6.CONSTRUCTION」(P7),「10.DISASSEMBLY DRAWING」(P15～P17).

TROUBLE		POSSIBLE CAUSE	REMEDY	Applicable model
Demarcation	Phenomenon			
Pressure	Pressure is not regulated.	1. Opposite flow direction or opposite installation of regulator.	1. Check flow direction and install the regulator correctly if wrong.	AWG20～40
		2. Adjust spring is damaged.	2. Replace the adjust spring.	AWG20～40
		3. Valve spring is damaged.	3. Replace the valve spring.	AWG20～40
		4. Foreign materials caught in valve seat or valve "O" ring.	4. Remove the valve guide to clean valve, valve seat and the valve "O" ring. Then, grease up the valve "O" ring and the sliding surface.	AWG20～40
		5. Valve rubber seat is damaged.	5. Replace the valve assembly.	AWG20～40
	Set pressure does not return to zero when pressure handle is loosened.	1. Foreign materials caught in valve seat or valve "O" ring.	1. Remove the valve guide to clean valve, valve seat and the valve "O" ring. Then, grease up the valve "O" ring and the sliding surface.	AWG20～40
		2. Valve rubber seat is damaged.	2. Replace the valve assembly.	AWG20～40
		3. Valve spring is damaged.	3. Replace the valve spring.	AWG20～40
		4. Valve adheres to the valve guide.	4. Wash the sliding surface of valve "O" ring and grease up.	AWG20～40
	Flow rate	resistance reduces flow rate.	1. Clog of the element.	1. Replace the element.
Air leaks	Air leaks from the bonnet exhaust port.	1. Diaphragm is damaged.	1. Replace the diaphragm assembly.	AWG20～40
		2. Foreign material is caught in the relieving valve seat.	2. Clean the relieving valve seat, or replace the diaphragm assembly.	AWG20～40
		3. Foreign material is caught in the valve seat of valve "O" ring.	3. Remove the valve guide to clean valve, valve seat and the valve "O" ring. Then, grease up the valve "O" ring and the sliding surface.	AWG20～40
		4. Valve rubber seat is damaged.	4. Replace the valve assembly.	AWG20～40
		5. Back pressure exceeding the set pressure is applied to the outlet.	5. Revise the air circuit so that back pressure does not exceed the set pressure.	AWG20～40
	between the bonnet and the body.	1. Loosened bonnet.	1. Fasten the bonnet.	AWG20～40
		2. Diaphragm is damaged.	2. Replace the diaphragm assembly.	AWG20～40
	Air leaks from the bowl and the body.	1. Breakage of "O" ring.	1. Replace the "O" ring. Grease up before assembling.	AWG20～40
	Air leaks from the bowl.	1. Breakage of bowl.	1. Replace the bowl assembly or with metal bowl.	AWG20～40
	Air leaks from the drain cock.	1. The foreign matter caught in the valve of the drain cock, the drain cock.	1. Open the drain cock for a few seconds for blowing.	AWG20～40
2. Breakage of the seating part of the drain cock.		2. Replace the bowl assembly.	AWG20～40	
Air leaks from the pressure gauge.	1. Foreign materials are caught in the pressure gauge "O" ring.	1. Remove the pressure gauge, and clean the pressure gauge "O" ring. After cleaning, apply grease to the pressure gauge "O" ring.	AWG20～40	
	2. Pressure gauge is damaged.	2. Replace the pressure gauge.	AWG20～40	
Operational	Draining isn't performed though the drain cock is opened.	1. Clog of outlet of the drain cock due to solid foreign matter etc.	1. Replace the bowl assembly.	AWG20～40
	Too much drain comes from the piping of secondary side.	1. Drain level reaches the baffle plate.	1. Open the drain cock for draining and replace the element.	AWG20～40

Note) The grease used recommends Mitsubishi diamond multipurpose No.2.



## 6. CONSTRUCTION/PARTS LIST

### AWG20

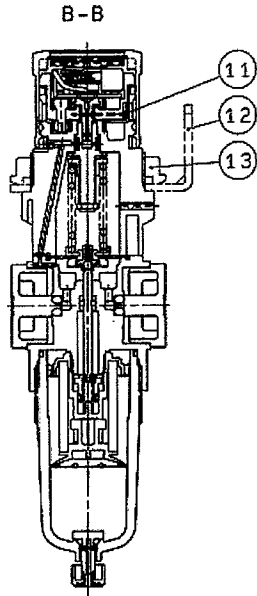
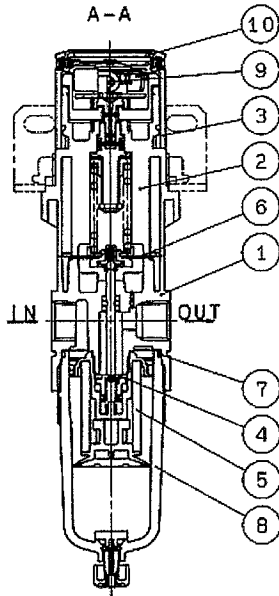
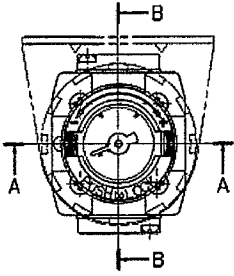

### AWG30,40

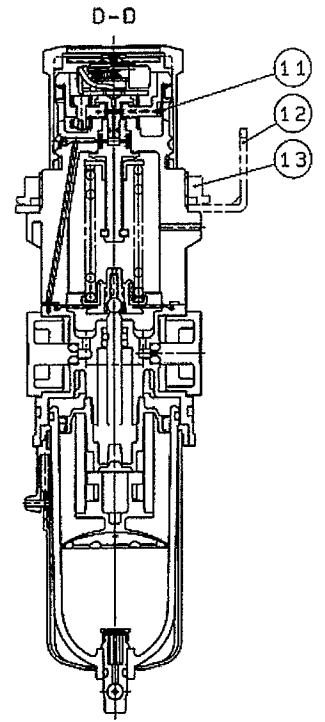
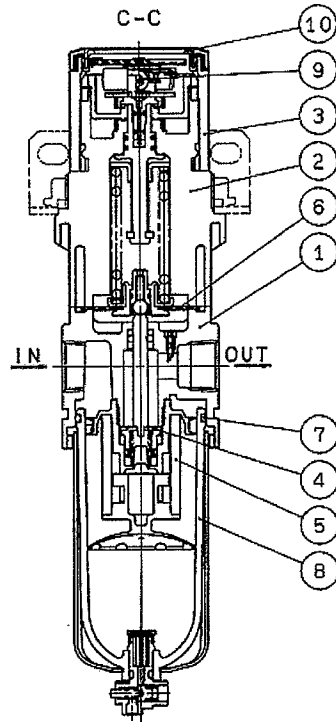
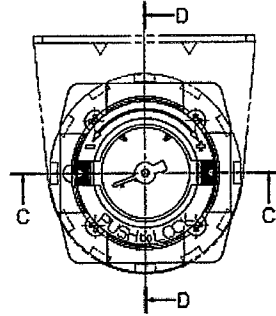

### COMPONENT PARTS

No.	Description	Material			Note
		AWG20	AWG30	AWG40	
①	Body	Zinc die cast	Aluminium die cast	Aluminium die cast	Painted platinum/silver
②	Bonnet		PBT		Painted black
③	Handle		POM		Painted black

### OPTION/REPLACEMENT PARTS

No.	Description	Option	Material	Part no.			
				AWG20	AWG30	AWG40	
④	Valve assembly	—	BRASS BAR+HNBR	AW20P-340AS	AW30P-340AS	AW40P-340AS	
⑤	Element	—	POLYOLEFIN	AF20P-060S	AF30P-060S	AF40P-060S	
⑥	Diaphragm assembly	—	Weatherproof NBR	AR20P-150AS	AR30P-150AS	AR40P-150AS	
		N	Weatherproof NBR	AR20P-150AS-N	AR30P-150AS-N	AR40P-150AS-N	
⑦	Bowl "O" ring	—	NBR	C2SFP-260S	C3SFP-260S	C4SFP-260S	
⑧	Bowl assembly	Refer to 「7. SPECIFICATIONS OF BOWL ASSEMBLY」(P8~P10).					
	Auto drain (N.C.)						
	Auto drain (N.O.)						
⑨	Pressure gauge	—	—	GB2-10AS	GB3-10AS	GB4-10AS	
		1	0~0.3MPa	—	GB2-3AS	GB3-3AS	GB4-3AS
		Z	0~150PSI	—	GB2-P10AS	GB3-P10AS	GB4-P10AS
		1Z	0~45PSI	—	GB2-P3AS	GB3-P3AS	GB4-P3AS
⑩	Pressure gauge cover	—	PC	ARG20P-400S	ARG30P-400S	ARG40P-400S	
⑪	Clip	—	Stainless steel wire	ARG20P-420S	ARG30P-420S	ARG40P-420S	
⑫	Note2) Bracket assembly	—	Steel plate+POM	AW20P-270AS	AR30P-270AS	AR40P-270AS	
⑬	Set nut	—	POM	AR20P-260S	AR30P-260S	AR40P-260S	

Note2) Bracket and Set nut assembly.

Note7) The number in the table is corresponding to the number in structural drawing (above-mentioned figure) and 「7.SPECIFICATIONS OF BOWL ASSEMBLY」(P8~P10),「10.DISASSEMBLY DRAWING」(P15~P17)

# 7. BOWL ASSEMBLY SPECIFICATIONS

## 1) Bowl assembly/Auto drain for AWG20

Accessory	—		Note2) C		—	
Option	—	6	—	6	J	6J
External appearance drawing Part no.	Option 「-」 (Standard) Port thread ⑧ Part no. Rc C2SF G C2SF(-Z) NPT C2SF(-Z)		Option 「-」 Port thread ⑧ Part no. Rc AD27 G AD27(-Z) NPT AD27(-Z)		Option 「J」 Port thread ⑧ Part no. Rc C2SF-J G C2SFF-J NPT C2SFN-J(Z)	
	Option 「6」 Port thread ⑧ Part no. Rc C2SF-6 G C2SF-6(Z) NPT C2SF-6(Z)		Option 「6」 Port thread ⑧ Part no. Rc AD27-6 G AD27-6(Z) NPT AD27-6(Z)		Option 「6J」 Port thread ⑧ Part no. Rc C2SF-6J G C2SFF-6J NPT C2SFN-6J(Z)	
Accessory	—		Note2) C		—	
Option	C	6C	C	6C	CJ	6CJ
External appearance drawing Part no.	Option 「C」 Port thread ⑧ Part no. Rc C2SF-C G C2SF-C(Z) NPT C2SF-C(Z)		Option 「C」 Port thread ⑧ Part no. Rc AD27-C G AD27-C(Z) NPT AD27-C(Z)		Option 「CJ」 Port thread ⑧ Part no. Rc C2SF-CJ G C2SFF-CJ NPT C2SFN-CJ(Z)	
	Option 「6C」 Port thread ⑧ Part no. Rc C2SF-6C G C2SF-6C(Z) NPT C2SF-6C(Z)		Option 「6C」 Port thread ⑧ Part no. Rc AD27-6C G AD27-6C(Z) NPT AD27-6C(Z)		Option 「6CJ」 Port thread ⑧ Part no. Rc C2SF-6CJ G C2SFF-6CJ NPT C2SFN-6CJ(Z)	
Accessory	—		Note2) C		—	
Option	2		2		2J	
External appearance drawing Part no.	Port thread ⑧ Part no. Rc C2SF-2 G C2SF-2(Z) NPT C2SF-2(Z)		Port thread ⑧ Part no. Rc AD27-2 G AD27-2(Z) NPT AD27-2(Z)		Port thread ⑧ Part no. Rc C2SF-2J G C2SFF-2J NPT C2SFN-2J(Z)	
			M5 X 0.8		1/8 HEX.14	

Note 1) B in the table shows full dimensions of the product. Refer to 「11. DIMENSIONS」 (P18).

Note 2) Min. operating pressure is 0.1MPa .

Note 3) The part with no. ⑧ includes ⑦ Bowl O ring. Refer to 「10. DISASSEMBLY DRAWING」 (P15~P17).

Note 4) "Z" of the part with no. ⑧ is semi-standard for indicated unit of pressure and temperature, which is PSI and ° F

Note 5) The symbol for option and semi-standard are described as 「4. HOW TO ORDER」(P5).

## 2) Bowl assembly/Auto drain for AWG30

Accessory	C		D		J		W																																																																																																													
Option	6		6		6J		6W																																																																																																													
External appearance drawing Part no.	<table border="1"> <tr><td>Option [F-] (Standard)</td><td>Port thread</td><td>Part no.</td><td>D</td></tr> <tr><td>Rc</td><td>C3SF</td><td>AD37</td><td>φ 10</td></tr> <tr><td>G</td><td>C3SF(-Z)</td><td>NPT</td><td>AD37N(-Z) φ 3/8"</td></tr> </table> <table border="1"> <tr><td>Option [6J]</td><td>Port thread</td><td>Part no.</td><td>D</td></tr> <tr><td>Rc</td><td>C3SF-6</td><td>AD37-6</td><td>φ 10</td></tr> <tr><td>G</td><td>C3SF-6(Z)</td><td>NPT</td><td>AD37N-6(Z) φ 3/8"</td></tr> </table>	Option [F-] (Standard)	Port thread	Part no.	D	Rc	C3SF	AD37	φ 10	G	C3SF(-Z)	NPT	AD37N(-Z) φ 3/8"	Option [6J]	Port thread	Part no.	D	Rc	C3SF-6	AD37-6	φ 10	G	C3SF-6(Z)	NPT	AD37N-6(Z) φ 3/8"	<table border="1"> <tr><td>Option [F-]</td><td>Port thread</td><td>Part no.</td><td>D</td></tr> <tr><td>Rc</td><td>AD38</td><td>φ 10</td><td></td></tr> <tr><td>G</td><td>AD38N(-Z)</td><td>φ 3/8"</td><td></td></tr> </table> <table border="1"> <tr><td>Option [6J]</td><td>Port thread</td><td>Part no.</td><td>D</td></tr> <tr><td>Rc</td><td>AD38-6</td><td>φ 10</td><td></td></tr> <tr><td>G</td><td>AD38N-6(Z)</td><td>φ 3/8"</td><td></td></tr> </table>	Option [F-]	Port thread	Part no.	D	Rc	AD38	φ 10		G	AD38N(-Z)	φ 3/8"		Option [6J]	Port thread	Part no.	D	Rc	AD38-6	φ 10		G	AD38N-6(Z)	φ 3/8"		<table border="1"> <tr><td>Option [J]</td><td>Port thread</td><td>Part no.</td><td>D</td></tr> <tr><td>Rc</td><td>C3SF-J</td><td>C3SF-J</td><td>T0604</td></tr> <tr><td>G</td><td>C3SF(-Z)</td><td>C3SF(-Z)</td><td></td></tr> <tr><td>NPT</td><td>C3SFN-6(Z)</td><td>C3SFN-6(Z)</td><td></td></tr> </table> <table border="1"> <tr><td>Option [6J]</td><td>Port thread</td><td>Part no.</td><td>D</td></tr> <tr><td>Rc</td><td>C3SF-6J</td><td>C3SF-6J</td><td>T0604</td></tr> <tr><td>G</td><td>C3SF-6(Z)</td><td>C3SF-6(Z)</td><td></td></tr> <tr><td>NPT</td><td>C3SFN-6J(Z)</td><td>C3SFN-6J(Z)</td><td></td></tr> </table>	Option [J]	Port thread	Part no.	D	Rc	C3SF-J	C3SF-J	T0604	G	C3SF(-Z)	C3SF(-Z)		NPT	C3SFN-6(Z)	C3SFN-6(Z)		Option [6J]	Port thread	Part no.	D	Rc	C3SF-6J	C3SF-6J	T0604	G	C3SF-6(Z)	C3SF-6(Z)		NPT	C3SFN-6J(Z)	C3SFN-6J(Z)		<table border="1"> <tr><td>Option [W]</td><td>Port thread</td><td>Part no.</td><td>D</td></tr> <tr><td>Rc</td><td>C3SF-W</td><td>C3SF-W</td><td>T0604</td></tr> <tr><td>G</td><td>C3SF(-WZ)</td><td>C3SF(-WZ)</td><td></td></tr> <tr><td>NPT</td><td>C3SFN-6(WZ)</td><td>C3SFN-6(WZ)</td><td></td></tr> </table> <table border="1"> <tr><td>Option [6W]</td><td>Port thread</td><td>Part no.</td><td>D</td></tr> <tr><td>Rc</td><td>C3SF-6W</td><td>C3SF-6W</td><td>T0604</td></tr> <tr><td>G</td><td>C3SF-6(WZ)</td><td>C3SF-6(WZ)</td><td></td></tr> <tr><td>NPT</td><td>C3SFN-6(WZ)</td><td>C3SFN-6(WZ)</td><td></td></tr> </table>	Option [W]	Port thread	Part no.	D	Rc	C3SF-W	C3SF-W	T0604	G	C3SF(-WZ)	C3SF(-WZ)		NPT	C3SFN-6(WZ)	C3SFN-6(WZ)		Option [6W]	Port thread	Part no.	D	Rc	C3SF-6W	C3SF-6W	T0604	G	C3SF-6(WZ)	C3SF-6(WZ)		NPT	C3SFN-6(WZ)	C3SFN-6(WZ)	
Option [F-] (Standard)	Port thread	Part no.	D																																																																																																																	
Rc	C3SF	AD37	φ 10																																																																																																																	
G	C3SF(-Z)	NPT	AD37N(-Z) φ 3/8"																																																																																																																	
Option [6J]	Port thread	Part no.	D																																																																																																																	
Rc	C3SF-6	AD37-6	φ 10																																																																																																																	
G	C3SF-6(Z)	NPT	AD37N-6(Z) φ 3/8"																																																																																																																	
Option [F-]	Port thread	Part no.	D																																																																																																																	
Rc	AD38	φ 10																																																																																																																		
G	AD38N(-Z)	φ 3/8"																																																																																																																		
Option [6J]	Port thread	Part no.	D																																																																																																																	
Rc	AD38-6	φ 10																																																																																																																		
G	AD38N-6(Z)	φ 3/8"																																																																																																																		
Option [J]	Port thread	Part no.	D																																																																																																																	
Rc	C3SF-J	C3SF-J	T0604																																																																																																																	
G	C3SF(-Z)	C3SF(-Z)																																																																																																																		
NPT	C3SFN-6(Z)	C3SFN-6(Z)																																																																																																																		
Option [6J]	Port thread	Part no.	D																																																																																																																	
Rc	C3SF-6J	C3SF-6J	T0604																																																																																																																	
G	C3SF-6(Z)	C3SF-6(Z)																																																																																																																		
NPT	C3SFN-6J(Z)	C3SFN-6J(Z)																																																																																																																		
Option [W]	Port thread	Part no.	D																																																																																																																	
Rc	C3SF-W	C3SF-W	T0604																																																																																																																	
G	C3SF(-WZ)	C3SF(-WZ)																																																																																																																		
NPT	C3SFN-6(WZ)	C3SFN-6(WZ)																																																																																																																		
Option [6W]	Port thread	Part no.	D																																																																																																																	
Rc	C3SF-6W	C3SF-6W	T0604																																																																																																																	
G	C3SF-6(WZ)	C3SF-6(WZ)																																																																																																																		
NPT	C3SFN-6(WZ)	C3SFN-6(WZ)																																																																																																																		
Accessory	2		2		2J		2J																																																																																																													
External appearance drawing Part no.	<table border="1"> <tr><td>Port thread</td><td>Part no.</td><td>D</td></tr> <tr><td>Rc</td><td>C3SF-2</td><td>φ 10</td></tr> <tr><td>G</td><td>C3SF-2(Z)</td><td></td></tr> <tr><td>NPT</td><td>C3SF-2(Z)</td><td></td></tr> </table>	Port thread	Part no.	D	Rc	C3SF-2	φ 10	G	C3SF-2(Z)		NPT	C3SF-2(Z)		<table border="1"> <tr><td>Port thread</td><td>Part no.</td><td>D</td></tr> <tr><td>Rc</td><td>AD38-2</td><td>φ 10</td></tr> <tr><td>G</td><td>AD38N-2(Z)</td><td>φ 3/8"</td></tr> </table>	Port thread	Part no.	D	Rc	AD38-2	φ 10	G	AD38N-2(Z)	φ 3/8"	<table border="1"> <tr><td>Port thread</td><td>Part no.</td><td>D</td></tr> <tr><td>Rc</td><td>C3SF-2J</td><td>C3SF-2J</td><td></td></tr> <tr><td>G</td><td>C3SF-2J</td><td>C3SF-2J</td><td></td></tr> <tr><td>NPT</td><td>C3SFN-2J(Z)</td><td>C3SFN-2J(Z)</td><td></td></tr> </table>	Port thread	Part no.	D	Rc	C3SF-2J	C3SF-2J		G	C3SF-2J	C3SF-2J		NPT	C3SFN-2J(Z)	C3SFN-2J(Z)		<table border="1"> <tr><td>Port thread</td><td>Part no.</td><td>D</td></tr> <tr><td>Rc</td><td>C3LF-8J</td><td>C3LF-8J</td><td></td></tr> <tr><td>G</td><td>C3LFF-8J</td><td>C3LFF-8J</td><td></td></tr> <tr><td>NPT</td><td>C3LFN-8J(Z)</td><td>C3LFN-8J(Z)</td><td></td></tr> </table>	Port thread	Part no.	D	Rc	C3LF-8J	C3LF-8J		G	C3LFF-8J	C3LFF-8J		NPT	C3LFN-8J(Z)	C3LFN-8J(Z)																																																														
Port thread	Part no.	D																																																																																																																		
Rc	C3SF-2	φ 10																																																																																																																		
G	C3SF-2(Z)																																																																																																																			
NPT	C3SF-2(Z)																																																																																																																			
Port thread	Part no.	D																																																																																																																		
Rc	AD38-2	φ 10																																																																																																																		
G	AD38N-2(Z)	φ 3/8"																																																																																																																		
Port thread	Part no.	D																																																																																																																		
Rc	C3SF-2J	C3SF-2J																																																																																																																		
G	C3SF-2J	C3SF-2J																																																																																																																		
NPT	C3SFN-2J(Z)	C3SFN-2J(Z)																																																																																																																		
Port thread	Part no.	D																																																																																																																		
Rc	C3LF-8J	C3LF-8J																																																																																																																		
G	C3LFF-8J	C3LFF-8J																																																																																																																		
NPT	C3LFN-8J(Z)	C3LFN-8J(Z)																																																																																																																		
Accessory	8		8		8J		8J																																																																																																													
External appearance drawing Part no.	<table border="1"> <tr><td>Port thread</td><td>Part no.</td><td>D</td></tr> <tr><td>Rc</td><td>C3LF-8</td><td>φ 10</td></tr> <tr><td>G</td><td>C3LF-8(Z)</td><td></td></tr> <tr><td>NPT</td><td>C3LF-8(Z)</td><td></td></tr> </table>	Port thread	Part no.	D	Rc	C3LF-8	φ 10	G	C3LF-8(Z)		NPT	C3LF-8(Z)		<table border="1"> <tr><td>Port thread</td><td>Part no.</td><td>D</td></tr> <tr><td>Rc</td><td>AD38-8</td><td>φ 10</td></tr> <tr><td>G</td><td>AD38N-8(Z)</td><td>φ 3/8"</td></tr> </table>	Port thread	Part no.	D	Rc	AD38-8	φ 10	G	AD38N-8(Z)	φ 3/8"	<table border="1"> <tr><td>Port thread</td><td>Part no.</td><td>D</td></tr> <tr><td>Rc</td><td>C3LF-8J</td><td>C3LF-8J</td><td></td></tr> <tr><td>G</td><td>C3LFF-8J</td><td>C3LFF-8J</td><td></td></tr> <tr><td>NPT</td><td>C3LFN-8J(Z)</td><td>C3LFN-8J(Z)</td><td></td></tr> </table>	Port thread	Part no.	D	Rc	C3LF-8J	C3LF-8J		G	C3LFF-8J	C3LFF-8J		NPT	C3LFN-8J(Z)	C3LFN-8J(Z)		<table border="1"> <tr><td>Port thread</td><td>Part no.</td><td>D</td></tr> <tr><td>Rc</td><td>C3LF-8J</td><td>C3LF-8J</td><td></td></tr> <tr><td>G</td><td>C3LFF-8J</td><td>C3LFF-8J</td><td></td></tr> <tr><td>NPT</td><td>C3LFN-8J(Z)</td><td>C3LFN-8J(Z)</td><td></td></tr> </table>	Port thread	Part no.	D	Rc	C3LF-8J	C3LF-8J		G	C3LFF-8J	C3LFF-8J		NPT	C3LFN-8J(Z)	C3LFN-8J(Z)																																																														
Port thread	Part no.	D																																																																																																																		
Rc	C3LF-8	φ 10																																																																																																																		
G	C3LF-8(Z)																																																																																																																			
NPT	C3LF-8(Z)																																																																																																																			
Port thread	Part no.	D																																																																																																																		
Rc	AD38-8	φ 10																																																																																																																		
G	AD38N-8(Z)	φ 3/8"																																																																																																																		
Port thread	Part no.	D																																																																																																																		
Rc	C3LF-8J	C3LF-8J																																																																																																																		
G	C3LFF-8J	C3LFF-8J																																																																																																																		
NPT	C3LFN-8J(Z)	C3LFN-8J(Z)																																																																																																																		
Port thread	Part no.	D																																																																																																																		
Rc	C3LF-8J	C3LF-8J																																																																																																																		
G	C3LFF-8J	C3LFF-8J																																																																																																																		
NPT	C3LFN-8J(Z)	C3LFN-8J(Z)																																																																																																																		

Note 1) B in the table shows full dimensions of the product. Refer to [11. DIMENSIONS] (P18).

Note 2) Min. operating pressure is 0.15MPa for N.C. type and 0.1MPa for N.O. type.

Note 3) The part with no. ⑧ includes Bowl O ring. Refer to [10. DISASSEMBLY DRAWING] (P15~17).



Note 4) "Z" of the part with no. ⑧ is semi-standard for indicated unit of pressure and temperature, which is PSI and ° F.

Note 5) The symbol for option and semi-standard are described as [4. HOW TO ORDER] (P5).

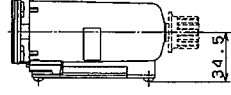
Metal bowl with sight glass

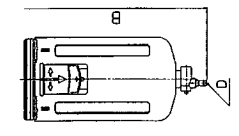

## 2) Bowl assembly/Auto drain for AWG40

Accessory	C		D		J	6J	W	6W																																																																												
Option	6		6		6J		6W																																																																													
External appearance drawing Part no.	<p>Option [F-J] (Standard)</p> <table border="1"> <tr><td>Port thread</td><td>ⒺPart no.</td></tr> <tr><td>Rc</td><td>C4SF</td></tr> <tr><td>G</td><td>C4SF-C</td></tr> <tr><td>NPT</td><td>C4SF-C(Z)</td></tr> </table> <p>Option [6]</p> <table border="1"> <tr><td>Port thread</td><td>ⒺPart no.</td></tr> <tr><td>Rc</td><td>C4SF-6</td></tr> <tr><td>G</td><td>C4SF-6</td></tr> <tr><td>NPT</td><td>C4SF-6(Z)</td></tr> </table>		Port thread	ⒺPart no.	Rc	C4SF	G	C4SF-C	NPT	C4SF-C(Z)	Port thread	ⒺPart no.	Rc	C4SF-6	G	C4SF-6	NPT	C4SF-6(Z)	<p>Option [F-J]</p> <table border="1"> <tr><td>Port thread</td><td>ⒺPart no.</td><td>D</td></tr> <tr><td>Rc</td><td>AD47</td><td>φ10</td></tr> <tr><td>G</td><td>NPT AD47N-Z</td><td>φ3/8"</td></tr> <tr><td>NPT</td><td>AD47N-Z(Z)</td><td>φ3/8"</td></tr> </table> <p>D: APPLICABLE TUBE EXTERNAL DIAMETER</p> <p>Option [6]</p> <table border="1"> <tr><td>Port thread</td><td>ⒺPart no.</td><td>D</td></tr> <tr><td>Rc</td><td>AD47-6</td><td>φ10</td></tr> <tr><td>G</td><td>NPT AD47N-6(Z)</td><td>φ3/8"</td></tr> <tr><td>NPT</td><td>AD47N-6(Z)</td><td>φ3/8"</td></tr> </table> <p>D: APPLICABLE TUBE EXTERNAL DIAMETER</p>		Port thread	ⒺPart no.	D	Rc	AD47	φ10	G	NPT AD47N-Z	φ3/8"	NPT	AD47N-Z(Z)	φ3/8"	Port thread	ⒺPart no.	D	Rc	AD47-6	φ10	G	NPT AD47N-6(Z)	φ3/8"	NPT	AD47N-6(Z)	φ3/8"	<p>Option [6J]</p> <table border="1"> <tr><td>Port thread</td><td>ⒺPart no.</td></tr> <tr><td>Rc</td><td>C4SF-J</td></tr> <tr><td>G</td><td>C4SFF-J</td></tr> <tr><td>NPT</td><td>C4SFN-J(Z)</td></tr> </table> <p>Option [6J]</p> <table border="1"> <tr><td>Port thread</td><td>ⒺPart no.</td></tr> <tr><td>Rc</td><td>C4SF-6J</td></tr> <tr><td>G</td><td>C4SFF-6J</td></tr> <tr><td>NPT</td><td>C4SFN-6J(Z)</td></tr> </table>		Port thread	ⒺPart no.	Rc	C4SF-J	G	C4SFF-J	NPT	C4SFN-J(Z)	Port thread	ⒺPart no.	Rc	C4SF-6J	G	C4SFF-6J	NPT	C4SFN-6J(Z)	<p>Option [W]</p> <table border="1"> <tr><td>Port thread</td><td>ⒺPart no.</td><td>D</td></tr> <tr><td>Rc</td><td>C4SF-W</td><td>T0604</td></tr> <tr><td>G</td><td>NPT C4SF-W(Z)</td><td></td></tr> </table> <p>D: APPLICABLE TUBE</p> <p>Option [6W]</p> <table border="1"> <tr><td>Port thread</td><td>ⒺPart no.</td><td>D</td></tr> <tr><td>Rc</td><td>C4SF-6W</td><td>T0604</td></tr> <tr><td>G</td><td>NPT C4SF-6W(Z)</td><td></td></tr> </table> <p>D: APPLICABLE TUBE</p>		Port thread	ⒺPart no.	D	Rc	C4SF-W	T0604	G	NPT C4SF-W(Z)		Port thread	ⒺPart no.	D	Rc	C4SF-6W	T0604	G	NPT C4SF-6W(Z)			
Port thread	ⒺPart no.																																																																																			
Rc	C4SF																																																																																			
G	C4SF-C																																																																																			
NPT	C4SF-C(Z)																																																																																			
Port thread	ⒺPart no.																																																																																			
Rc	C4SF-6																																																																																			
G	C4SF-6																																																																																			
NPT	C4SF-6(Z)																																																																																			
Port thread	ⒺPart no.	D																																																																																		
Rc	AD47	φ10																																																																																		
G	NPT AD47N-Z	φ3/8"																																																																																		
NPT	AD47N-Z(Z)	φ3/8"																																																																																		
Port thread	ⒺPart no.	D																																																																																		
Rc	AD47-6	φ10																																																																																		
G	NPT AD47N-6(Z)	φ3/8"																																																																																		
NPT	AD47N-6(Z)	φ3/8"																																																																																		
Port thread	ⒺPart no.																																																																																			
Rc	C4SF-J																																																																																			
G	C4SFF-J																																																																																			
NPT	C4SFN-J(Z)																																																																																			
Port thread	ⒺPart no.																																																																																			
Rc	C4SF-6J																																																																																			
G	C4SFF-6J																																																																																			
NPT	C4SFN-6J(Z)																																																																																			
Port thread	ⒺPart no.	D																																																																																		
Rc	C4SF-W	T0604																																																																																		
G	NPT C4SF-W(Z)																																																																																			
Port thread	ⒺPart no.	D																																																																																		
Rc	C4SF-6W	T0604																																																																																		
G	NPT C4SF-6W(Z)																																																																																			
Accessory	C		D		J	6J	W	6W																																																																												
Option	2		2		2J		2J																																																																													
External appearance drawing Part no.	<p>Option [F-J]</p> <table border="1"> <tr><td>Port thread</td><td>ⒺPart no.</td><td>D</td></tr> <tr><td>Rc</td><td>AD47-2</td><td>φ10</td></tr> <tr><td>G</td><td>NPT AD47N-2(Z)</td><td>φ3/8"</td></tr> </table> <p>D: APPLICABLE TUBE EXTERNAL DIAMETER</p> <p>Option [6]</p> <table border="1"> <tr><td>Port thread</td><td>ⒺPart no.</td><td>D</td></tr> <tr><td>Rc</td><td>AD48-6</td><td>φ10</td></tr> <tr><td>G</td><td>NPT AD48N-6(Z)</td><td>φ3/8"</td></tr> </table> <p>D: APPLICABLE TUBE EXTERNAL DIAMETER</p>		Port thread	ⒺPart no.	D	Rc	AD47-2	φ10	G	NPT AD47N-2(Z)	φ3/8"	Port thread	ⒺPart no.	D	Rc	AD48-6	φ10	G	NPT AD48N-6(Z)	φ3/8"	<p>Option [F-J]</p> <table border="1"> <tr><td>Port thread</td><td>ⒺPart no.</td><td>D</td></tr> <tr><td>Rc</td><td>AD48</td><td>φ10</td></tr> <tr><td>G</td><td>NPT AD48N-(Z)</td><td>φ3/8"</td></tr> </table> <p>D: APPLICABLE TUBE EXTERNAL DIAMETER</p> <p>Option [6J]</p> <table border="1"> <tr><td>Port thread</td><td>ⒺPart no.</td></tr> <tr><td>Rc</td><td>C4SF-2J</td></tr> <tr><td>G</td><td>C4SFF-2J</td></tr> <tr><td>NPT</td><td>C4SFN-2J(Z)</td></tr> </table>		Port thread	ⒺPart no.	D	Rc	AD48	φ10	G	NPT AD48N-(Z)	φ3/8"	Port thread	ⒺPart no.	Rc	C4SF-2J	G	C4SFF-2J	NPT	C4SFN-2J(Z)	<p>Option [W]</p> <table border="1"> <tr><td>Port thread</td><td>ⒺPart no.</td><td>D</td></tr> <tr><td>Rc</td><td>C4SF-W</td><td>T0604</td></tr> <tr><td>G</td><td>NPT C4SF-W(Z)</td><td></td></tr> </table> <p>D: APPLICABLE TUBE</p> <p>Option [6W]</p> <table border="1"> <tr><td>Port thread</td><td>ⒺPart no.</td><td>D</td></tr> <tr><td>Rc</td><td>C4SF-6W</td><td>T0604</td></tr> <tr><td>G</td><td>NPT C4SF-6W(Z)</td><td></td></tr> </table> <p>D: APPLICABLE TUBE</p>		Port thread	ⒺPart no.	D	Rc	C4SF-W	T0604	G	NPT C4SF-W(Z)		Port thread	ⒺPart no.	D	Rc	C4SF-6W	T0604	G	NPT C4SF-6W(Z)																										
Port thread	ⒺPart no.	D																																																																																		
Rc	AD47-2	φ10																																																																																		
G	NPT AD47N-2(Z)	φ3/8"																																																																																		
Port thread	ⒺPart no.	D																																																																																		
Rc	AD48-6	φ10																																																																																		
G	NPT AD48N-6(Z)	φ3/8"																																																																																		
Port thread	ⒺPart no.	D																																																																																		
Rc	AD48	φ10																																																																																		
G	NPT AD48N-(Z)	φ3/8"																																																																																		
Port thread	ⒺPart no.																																																																																			
Rc	C4SF-2J																																																																																			
G	C4SFF-2J																																																																																			
NPT	C4SFN-2J(Z)																																																																																			
Port thread	ⒺPart no.	D																																																																																		
Rc	C4SF-W	T0604																																																																																		
G	NPT C4SF-W(Z)																																																																																			
Port thread	ⒺPart no.	D																																																																																		
Rc	C4SF-6W	T0604																																																																																		
G	NPT C4SF-6W(Z)																																																																																			
Accessory	C		D		J	6J	W	6W																																																																												
Option	8		8		8J		8J																																																																													
External appearance drawing Part no.	<p>Option [F-J]</p> <table border="1"> <tr><td>Port thread</td><td>ⒺPart no.</td><td>D</td></tr> <tr><td>Rc</td><td>AD47-8</td><td>φ10</td></tr> <tr><td>G</td><td>NPT AD47N-8(Z)</td><td>φ3/8"</td></tr> </table> <p>D: APPLICABLE TUBE EXTERNAL DIAMETER</p> <p>Option [6]</p> <table border="1"> <tr><td>Port thread</td><td>ⒺPart no.</td><td>D</td></tr> <tr><td>Rc</td><td>AD48-8</td><td>φ10</td></tr> <tr><td>G</td><td>NPT AD48N-8(Z)</td><td>φ3/8"</td></tr> </table> <p>D: APPLICABLE TUBE EXTERNAL DIAMETER</p>		Port thread	ⒺPart no.	D	Rc	AD47-8	φ10	G	NPT AD47N-8(Z)	φ3/8"	Port thread	ⒺPart no.	D	Rc	AD48-8	φ10	G	NPT AD48N-8(Z)	φ3/8"	<p>Option [F-J]</p> <table border="1"> <tr><td>Port thread</td><td>ⒺPart no.</td><td>D</td></tr> <tr><td>Rc</td><td>AD48-8</td><td>φ10</td></tr> <tr><td>G</td><td>NPT AD48N-8(Z)</td><td>φ3/8"</td></tr> </table> <p>D: APPLICABLE TUBE EXTERNAL DIAMETER</p> <p>Option [6J]</p> <table border="1"> <tr><td>Port thread</td><td>ⒺPart no.</td></tr> <tr><td>Rc</td><td>C4LF-8J</td></tr> <tr><td>G</td><td>C4LFF-8J</td></tr> <tr><td>NPT</td><td>C4LFN-8J(Z)</td></tr> </table>		Port thread	ⒺPart no.	D	Rc	AD48-8	φ10	G	NPT AD48N-8(Z)	φ3/8"	Port thread	ⒺPart no.	Rc	C4LF-8J	G	C4LFF-8J	NPT	C4LFN-8J(Z)	<p>Option [W]</p> <table border="1"> <tr><td>Port thread</td><td>ⒺPart no.</td><td>D</td></tr> <tr><td>Rc</td><td>C4SF-W</td><td>T0604</td></tr> <tr><td>G</td><td>NPT C4SF-W(Z)</td><td></td></tr> </table> <p>D: APPLICABLE TUBE</p> <p>Option [6W]</p> <table border="1"> <tr><td>Port thread</td><td>ⒺPart no.</td><td>D</td></tr> <tr><td>Rc</td><td>C4SF-6W</td><td>T0604</td></tr> <tr><td>G</td><td>NPT C4SF-6W(Z)</td><td></td></tr> </table> <p>D: APPLICABLE TUBE</p>		Port thread	ⒺPart no.	D	Rc	C4SF-W	T0604	G	NPT C4SF-W(Z)		Port thread	ⒺPart no.	D	Rc	C4SF-6W	T0604	G	NPT C4SF-6W(Z)																										
Port thread	ⒺPart no.	D																																																																																		
Rc	AD47-8	φ10																																																																																		
G	NPT AD47N-8(Z)	φ3/8"																																																																																		
Port thread	ⒺPart no.	D																																																																																		
Rc	AD48-8	φ10																																																																																		
G	NPT AD48N-8(Z)	φ3/8"																																																																																		
Port thread	ⒺPart no.	D																																																																																		
Rc	AD48-8	φ10																																																																																		
G	NPT AD48N-8(Z)	φ3/8"																																																																																		
Port thread	ⒺPart no.																																																																																			
Rc	C4LF-8J																																																																																			
G	C4LFF-8J																																																																																			
NPT	C4LFN-8J(Z)																																																																																			
Port thread	ⒺPart no.	D																																																																																		
Rc	C4SF-W	T0604																																																																																		
G	NPT C4SF-W(Z)																																																																																			
Port thread	ⒺPart no.	D																																																																																		
Rc	C4SF-6W	T0604																																																																																		
G	NPT C4SF-6W(Z)																																																																																			

Metal bowl with sight glass

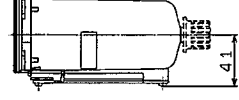

Note 1) B in the table shows full dimensions of the product. Refer to [11. DIMENSIONS] (P18).  
 Note 2) Min. operating pressure is 0.15MPa for N.C. type and 0.1MPa for N.O. type.  
 Note 3) The part with no. Ⓔ includes ⑦ Bowl O ring. Refer to [10. DISASSEMBLY DRAWING] (P15~17).  
 Note 4) "Z" of the part with no. Ⓔ is semi-standard for indicated unit of pressure and temperature, which is PSI and ° F  
 Note 5) The symbol for option and semi-standard are described as [4. HOW TO ORDER] (P5).

## 8. REPLACEMENT PROCEDURE

### WARNING

Before replacement, ensure that the regulator is not pressurized.

Rotate the pressure adjusting handle to zero.

Replace referring to 「10. DISASSEMBLY DRAWING」 (P15~P17).

After replacement, ensure that specified function is satisfied and external leakage is not found before starting operation.

#### 1) Bowl assembly/element

Applicable model	Process	Procedure	Tools	Check item
AWG20	Disassembly	1) Remove the bowl assembly. Hold the bowl assembly by hand and rotate counterclockwise to remove the bowl assembly. If the bowl assembly is tightened too much to be removed, use hook spanner until it can be loosened by hand.	(Hook spanner) (Nominal: 34/38)	—
		2) Remove the baffle element. Rotate the baffle by hand and counterclockwise to remove the baffle and element.	—	—
	Assembly	3) Mount the element. Mount the element to the element guide.	—	—
		4) Mount the baffle. Insert the baffle so that concave on the valve guide could meet T convex on the baffle. And rotate it clockwise manually until feeling snap fit (approx. 110° ) to fix to the element.	—	—
		5) Remove the bowl assembly. Hold the bowl assembly by hand and rotate counterclockwise to remove the bowl assembly. If the bowl assembly is tightened too much to be removed, use hook spanner until it can be loosened by hand.	—	Referential tightening torque: 2.2 N·m
AWG30 AWG40	Disassembly	1) Remove the bowl assembly. Hold the bowl assembly by hand and rotate counterclockwise to remove the bowl assembly. If the bowl assembly is tightened too much to be removed, use hook spanner until it can be loosened by hand.	—	—
		2) Remove the baffle element. Rotate the baffle by hand and counterclockwise to remove the baffle and element.	—	—
	Assembly	3) Mount the element. Mount the element to the element guide.	—	—
		4) Mount the baffle. Insert the baffle so that concave on the valve guide could meet T convex on the baffle. And rotate it clockwise manually until feeling snap fit (approx. 110° ) to fix to the element.	—	Direction of baffle. For element convex side.
		5) Mount the bowl assembly. Hold the bowl assembly by hand and rotate clockwise. Do not use tool for mounting because the bowl may be damaged. See check item for referential tightening torque.	—	Lock button is up.

#### 2) Diaphragm assembly

Applicable model	Process	Procedure	Tool	Check item						
AWG20	Disassembly	1) Remove the bonnet assembly. Rotate the set screw counterclockwise with cross pointed driver to remove the bonnet from the body.	Cross pointed driver	—						
		2) Remove parts in order of the pressure adjusting spring, and the diaphragm assembly.	—	—						
	Assembly	3) Mount parts to the body in order of the diaphragm assembly, pressure adjusting spring.	—	Diaphragm						
		4) Mount the bonnet to the body. Mount the bonnet to the body, and settle it roughly with four(4) set screws with a cross pointed driver. Then, Tighten screws diagonally with the tightening torque in the check item to settle.	Cross pointed driver	<table border="1"> <thead> <tr> <th colspan="2">Tightening torque</th> </tr> </thead> <tbody> <tr> <td>AWG20</td> <td>2.15±0.3N·m</td> </tr> <tr> <td>AWG30</td> <td>2.35±0.3N·m</td> </tr> <tr> <td>AWG40</td> <td>3.5 ±0.3N·m</td> </tr> </tbody> </table>	Tightening torque		AWG20	2.15±0.3N·m	AWG30	2.35±0.3N·m
Tightening torque										
AWG20	2.15±0.3N·m									
AWG30	2.35±0.3N·m									
AWG40	3.5 ±0.3N·m									

### 3) Valve assembly

Applicable model	Proess	Procedure	Tool	Check item						
AWG20 AWG30 AWG40	Disassembly	1) Remove valve guid after removeing bowl assembly and element.Hold the valve guide with a spanner to rotate it counterclockwise and remove the valve guide.	Spanner Nominal: 7	—						
		2) Remove the valve spring.	—	—						
		3) Remove the valve.	—	—						
	Assembly	4) Mount the valve. Mount the valve so that convex on the valve could be turned to the valve guide.	—	Presence of chamber. Mount if there is not a chamber direction						
		5) Mount the valve spring. Insert internal circumference of the valve spring to the convex on the valve.	—	—						
		6) Mount the valve guide. Hold the valve guide with a spanner to rotate it clockwise and mount the valve guide. See check item for the tightening torque.	Spanner Nominal: 7	<table border="1"> <thead> <tr> <th colspan="2">Tightening torque</th> </tr> </thead> <tbody> <tr> <td>AWG20</td> <td><math>0.8 \pm 0.1 \text{N} \cdot \text{m}</math></td> </tr> <tr> <td>AWG30</td> <td><math>2.35 \pm 0.3 \text{N} \cdot \text{m}</math></td> </tr> <tr> <td>AWG40</td> <td><math>3.5 \pm 0.3 \text{N} \cdot \text{m}</math></td> </tr> </tbody> </table>	Tightening torque		AWG20	$0.8 \pm 0.1 \text{N} \cdot \text{m}$	AWG30	$2.35 \pm 0.3 \text{N} \cdot \text{m}$
Tightening torque										
AWG20	$0.8 \pm 0.1 \text{N} \cdot \text{m}$									
AWG30	$2.35 \pm 0.3 \text{N} \cdot \text{m}$									
AWG40	$3.5 \pm 0.3 \text{N} \cdot \text{m}$									

### 4) Bracket assembly, panel mount

Applicable model	Proess	Procedure	Tool	Check item														
AWG20 AWG30 AWG40	Assembly	1) Mount the parts to the bracket(panel) Mate the bracket(panel) concave and the bonnet convex to mount the bracket.	—	—														
		2) Settle the bracket(panel) with set nut. Rotate the set nut clockwise with a hook spanner to settle the parts to the bracket(panel).See check item for tightening torque.Set nut knurling surface shall face the bracket. When mounting with bracket, set nut tightened manually is adequate fir general used.(AWG20~40)	<table border="1"> <thead> <tr> <th colspan="2">AWG20/30/40 Hook spanner Nominal</th> </tr> </thead> <tbody> <tr> <td>AWG20</td> <td>52/55</td> </tr> <tr> <td>AWG30</td> <td>58/65</td> </tr> <tr> <td>AWG40</td> <td>65/70</td> </tr> </tbody> </table>	AWG20/30/40 Hook spanner Nominal		AWG20	52/55	AWG30	58/65	AWG40	65/70	<table border="1"> <thead> <tr> <th colspan="2">Tightening torque</th> </tr> </thead> <tbody> <tr> <td>AWG20</td> <td><math>2.0 \pm 0.2 \text{N} \cdot \text{m}</math></td> </tr> <tr> <td>AWG30</td> <td><math>3.5 \pm 0.3 \text{N} \cdot \text{m}</math></td> </tr> <tr> <td>AWG40</td> <td><math>4.0 \pm 0.4 \text{N} \cdot \text{m}</math></td> </tr> </tbody> </table>	Tightening torque		AWG20	$2.0 \pm 0.2 \text{N} \cdot \text{m}$	AWG30	$3.5 \pm 0.3 \text{N} \cdot \text{m}$
AWG20/30/40 Hook spanner Nominal																		
AWG20	52/55																	
AWG30	58/65																	
AWG40	65/70																	
Tightening torque																		
AWG20	$2.0 \pm 0.2 \text{N} \cdot \text{m}$																	
AWG30	$3.5 \pm 0.3 \text{N} \cdot \text{m}$																	
AWG40	$4.0 \pm 0.4 \text{N} \cdot \text{m}$																	

## 8. PROCEDURE OF THE PRESSURE GAUGE REPLACEMENT AND ANGLE ADJUSTMENT

### WARNING

Before replacement, ensure that the regulator is not pressurized.

Rotate the pressure adjusting handle to zero.

After replacement, ensure that specified function is satisfied and external leakage is not found before starting operation.

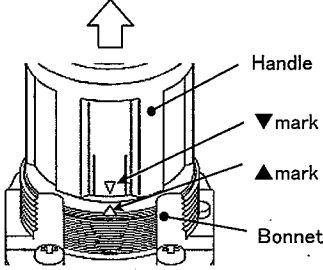
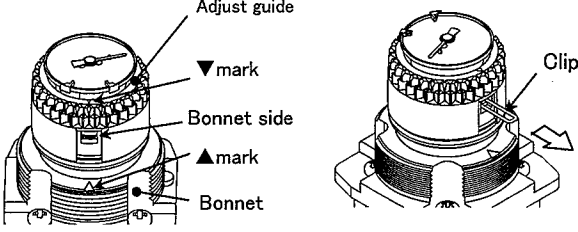
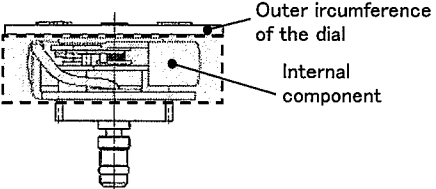
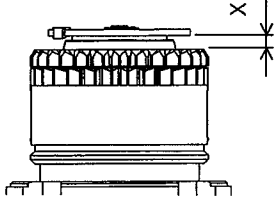
Applicable model	Process	Procedure	Tools	Check item								
AWG20 AWG30 AWG40	Disassembly	1) Preparation Release the handle lock with the pressure adjusting handle completely loosened.	—	Orange line can be seen between the handle and the bonnet.								
		2) Removal of the handle. Pull out the handle to remove at the position where ▼ mark of the handle and ▲ mark of the bonnet meet. 	—	—								
		3) Removal of the clip. The clip becomes visible from the side window of the bonnet if ▲ mark of the bonnet and ▼ mark of the pressure adjusting guide meet. pull out the clip with tweezers. ※Retate the pressure adjusting guide clockwise when matching the mark. 	Tweezers	—								
		4) Removal of the pressure gauge. Pill out the pressure gauge holding the outer circumference of the dial. ※ Don't touch the internal component of the pressure gauge (surrounded by broken line).It may damage the indication accuracy of the pressure gauge. 	—	—								
	Assembly	5) Setting the pressure gauge Hold the outer circumference of the dial and set the gauge at specified angle, and push in the gauge lightly. For reference, table 1 shows the gap dimension between the bottom surface of the dial and the top surface of the pressure adjusting guide after mounting the pressure gauge. Note1) If the gauge does not enter by some interference when setting the pressure gauge, set the gauge by slightly rotating it in rotating direction. (The planetary gear of the pressure adjusting guide and the sun gear integrated in the pressure gauge interfere each other) Note2) Set the pressure gauge completely. Note3) The end of the pressure gauge has greased O ring. Attention should be taken so that dust and particle not enter to the pressure gauge.	—	 FIG.1.Gap dimension <table border="1" data-bbox="1177 1899 1501 1995"> <thead> <tr> <th></th> <th>AWG20</th> <th>AWG30</th> <th>AWG40</th> </tr> </thead> <tbody> <tr> <td>X dimension (Reference value)</td> <td>2.6mm</td> <td>3.3mm</td> <td>3.3mm</td> </tr> </tbody> </table>		AWG20	AWG30	AWG40	X dimension (Reference value)	2.6mm	3.3mm	3.3mm
	AWG20	AWG30	AWG40									
X dimension (Reference value)	2.6mm	3.3mm	3.3mm									

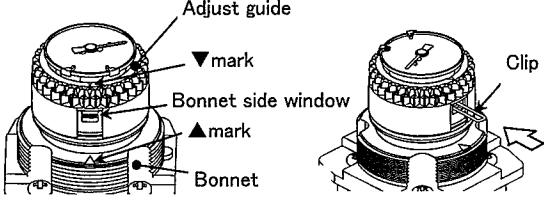
Applicable model	Process	Procedure	Tools	Check item
AWG20 AWG30 AWG40	Assembly	<p>6) Setting the clip.            Insert the clip from the wide window of the bonnet where ▲ mark of the pressure adjusting guide and ▼ mark of the bonnet meet. Use something sharp like tweezers when inserting the clip to the end. If the clip is not inserted to the end the handle may not rotate after setting the handle.</p> <p>Note1) Clip is slightly tapered to the end to avoid falling off. Slightly open the end of the clip when setting the clip.</p> <p>Note2) Following causes are possible when the clip is stuck in the middle.</p> <p>① The pressure adjusting screw is lower than the original position. (Gap is made between the pressure adjusting nut and the pressure adjusting spring. When the pressure adjusting screw is completely loosened, the pressure adjusting screw may be lowered. Countermeasure... Turn the pressure adjusting guide approx. 5 times clockwise (pressure rise direction).)</p> <p>② Pressure gauge is not properly set.            Countermeasure... 5) See setting the pressure gauge.</p> 	Tweezers	—
		<p>7) Setting the handle            Set the handle, and finish.</p>	—	—



# 10. DISASSEMBLY DRAWING

## 1) AWG20 Disassembly drawing

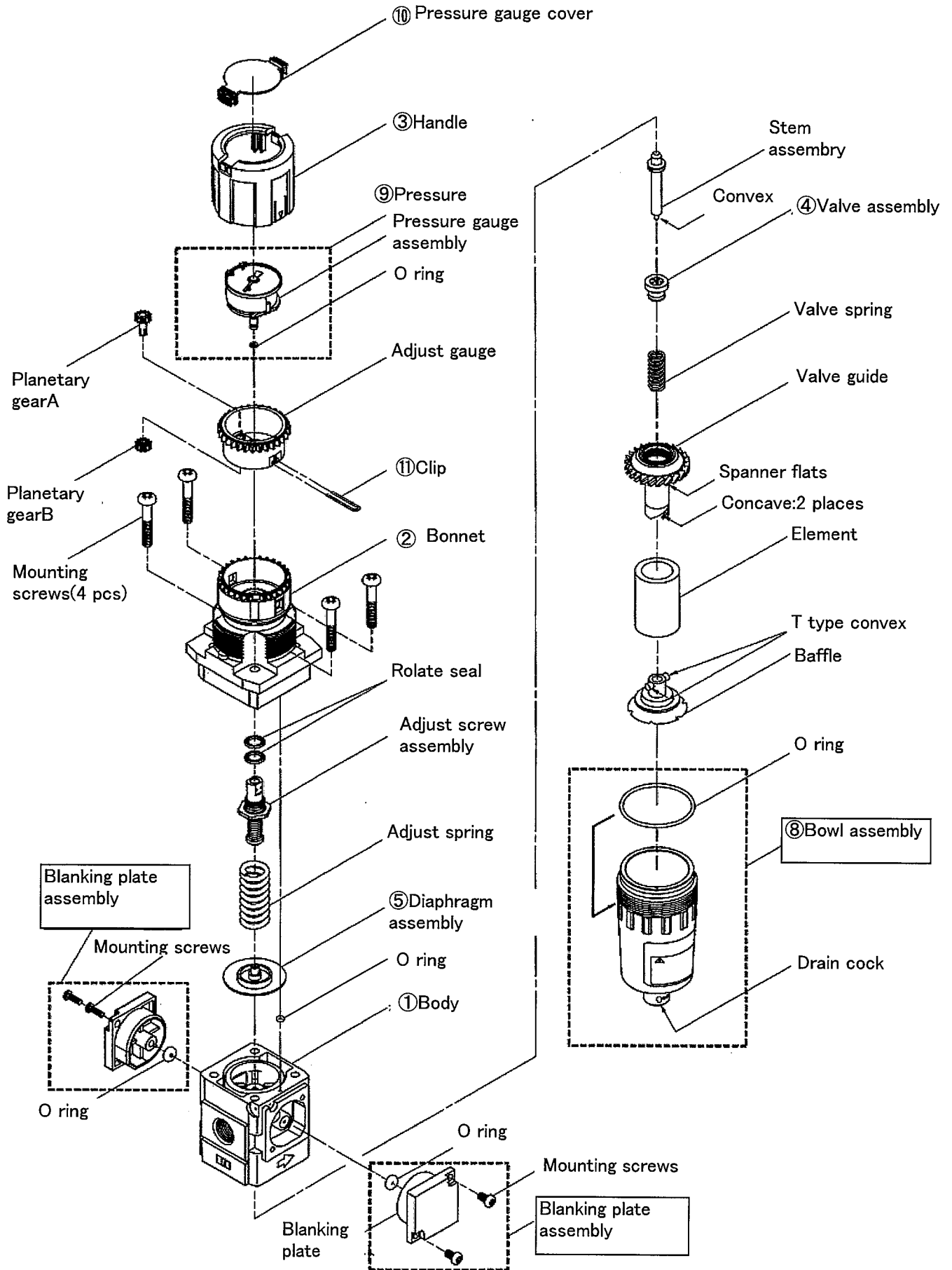

2)AWG30·40分解图

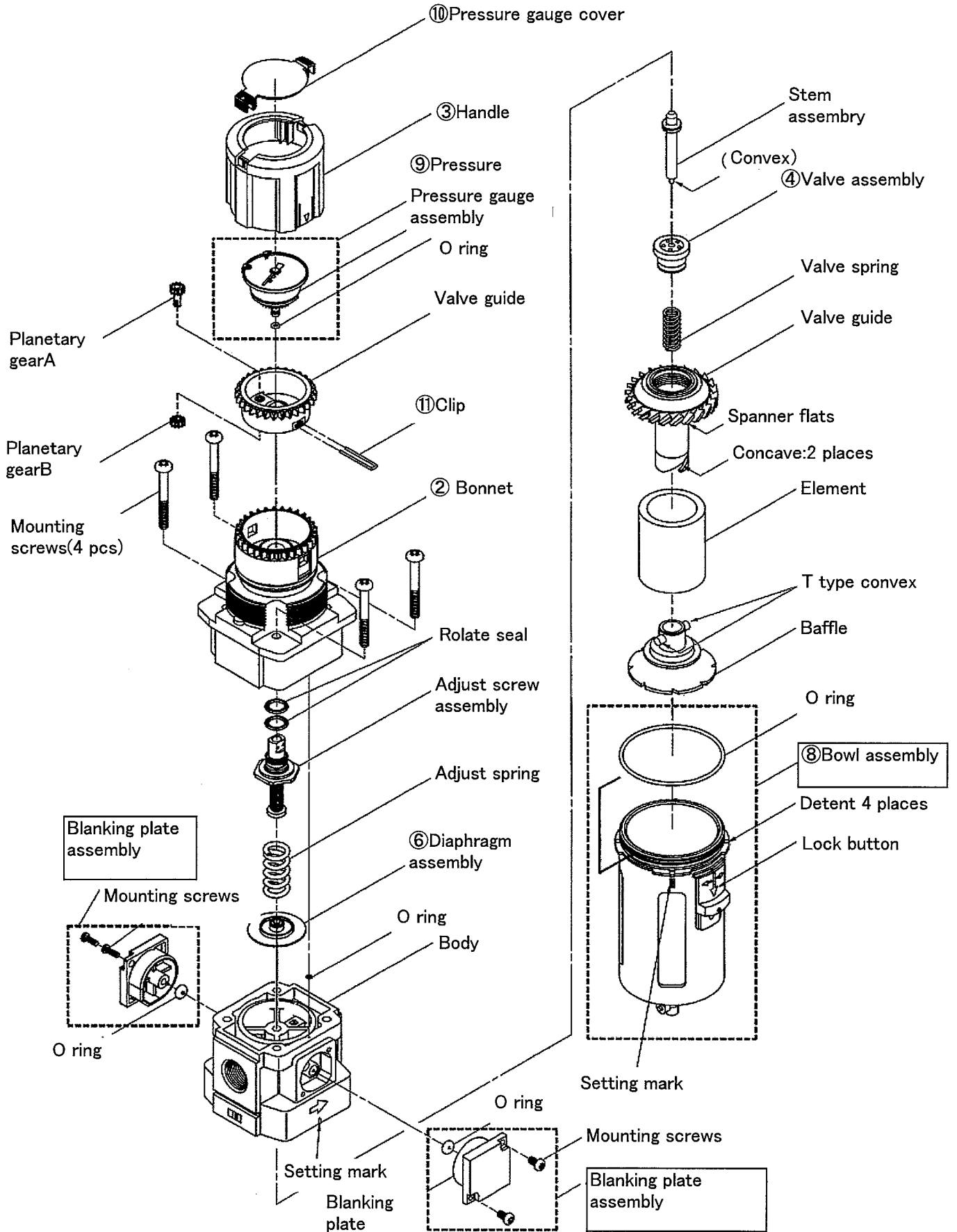

3)AWG20/30/40 Bracket assembly•panel mounting disassembly drawing

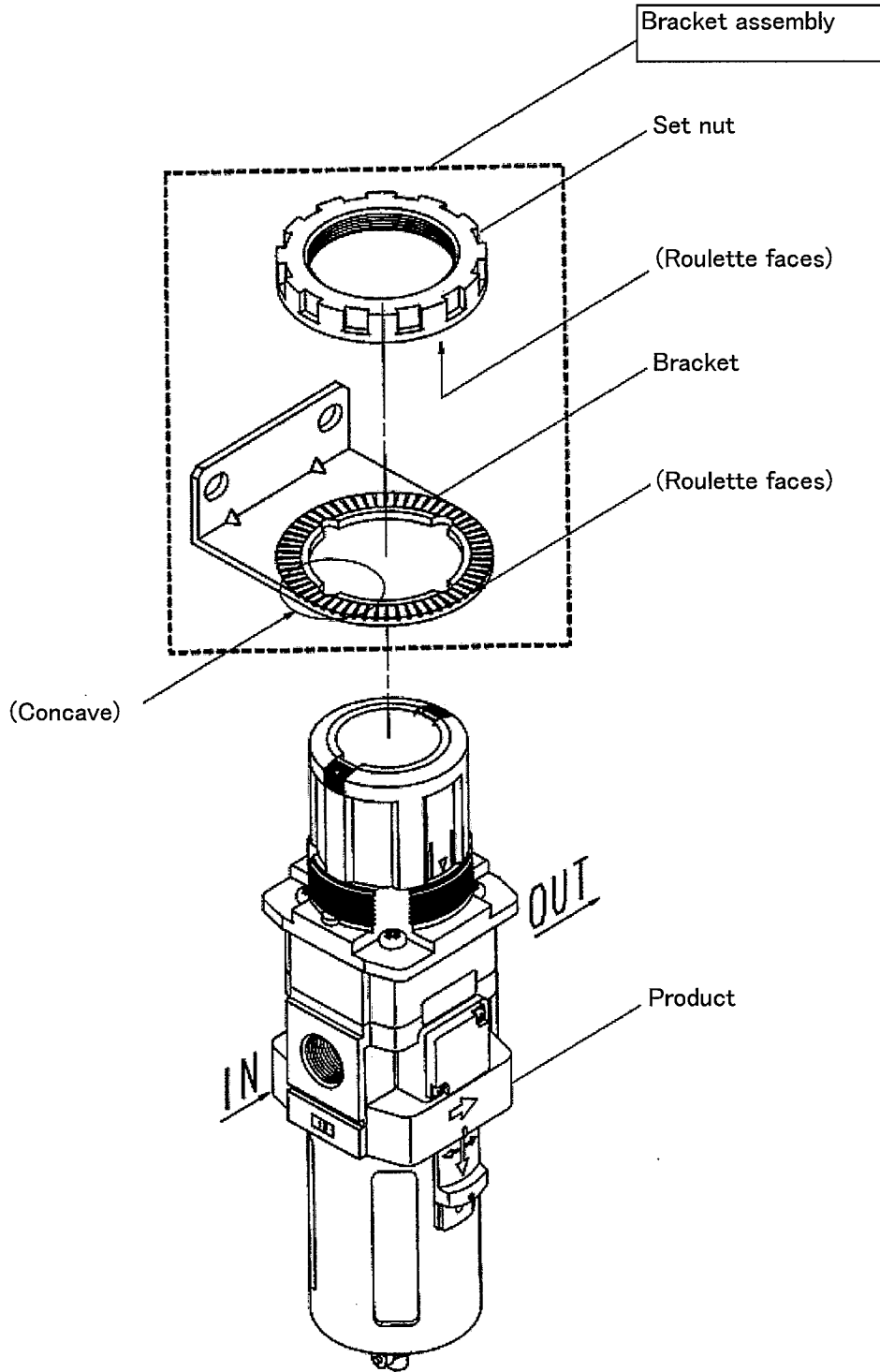

# 11. DIMENSIONS

## AWG20

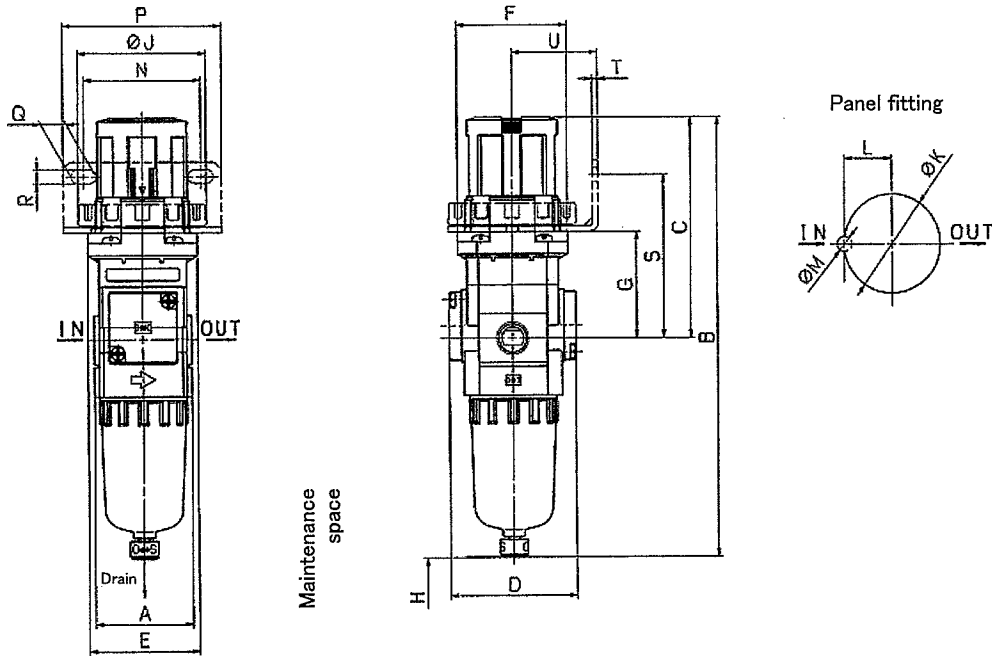

## AWG30,40

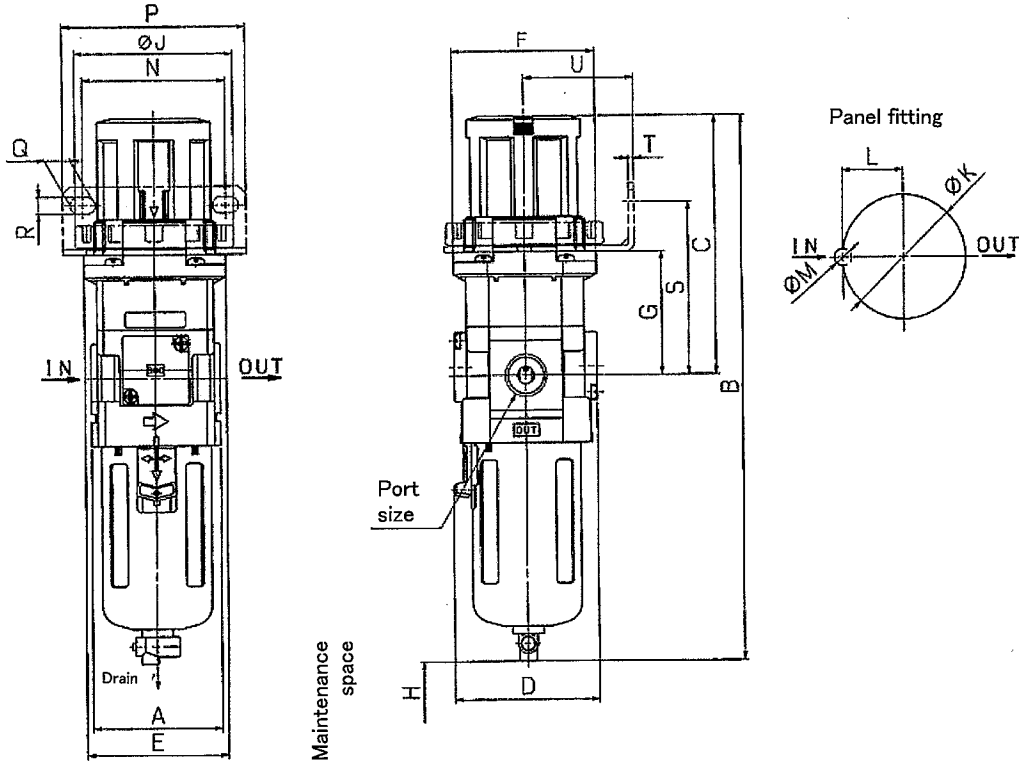

### Dimensions

Model	Port size	Standard							Accessory											
									Panel mounting						Bracket mounting dimensions					
		A	B <sup>※1)</sup>	C	D	E	F	H	G	J	K	L	M	N	P	Q	R	S	T	U
AWG20	1/8·1/4	40	179	91	52	45	45	40	43	52.5	39.5	19.5	6.0	48	65	10.4	5.4	65	2.3	35
AWG30	1/4·3/8	53	223.5	108.5	59	58	58.8	55	50	65	50.5	25	7.0	58.5	75	10.5	6.5	70	2.3	45
AWG40	1/4·3/8·1/2	70	261.5	114.5	75	70	70	80	56	70	55.5	27.5	7.0	70	85	12.5	8.5	77	2.3	50

### B for Auto-drain/Optional bowl assembly

Model	Accessory											C				D									
	Option																								
	2	6	8	C	6C	J	2J	6J	8J	CJ	6CJ	W	6W	-	2	6	8	C	6C	-	2	6	8		
AWG20	179	179	-	179	179	183	186	183	-	183	183	-	-	177	177	177	-	177	177	-	-	-	-		
AWG30	236.5	223.5	256.5	-	-	230.5	230.5	230.5	250.5	-	-	231.5	231.5	264.5	264.5	264.5	264.5	-	-	-	-	264.5	264.5	264.5	
AWG40	273.5	261.5	294.5	-	-	268.5	268.5	268.5	288.5	-	-	269.5	269.5	300.5	303.5	300.5	303.5	-	-	-	-	300.5	303.5	300.5	303.5

Note 1) The specifications of auto-drain and optional bowl assembly are described in 「7. SPECIFICATIONS OF BOWL ASSEMBLY」 (P8~P10).