



Instruction Manual
Digital Flow Switch – Integrated Display
PFM7 series



The intended use of the digital flow sensor is to monitor and control flow and provide an output signal.

1 Safety Instructions

These safety instructions are intended to prevent hazardous situations and/or equipment damage. These instructions indicate the level of potential hazard with the labels of "Caution," "Warning" or "Danger." They are all important notes for safety and must be followed in addition to International Standards (ISO/IEC) ⁽¹⁾, and other safety regulations.

- ⁽¹⁾ ISO 4414: Pneumatic fluid power - General rules relating to systems.
- ISO 4413: Hydraulic fluid power - General rules relating to systems.
- IEC 60204-1: Safety of machinery - Electrical equipment of machines. (Part 1: General requirements)
- ISO 10218-1: Manipulating industrial robots -Safety. etc.
- Refer to product catalogue, Operation Manual and Handling Precautions for SMC Products for additional information.
- Keep this manual in a safe place for future reference.

Caution	Caution indicates a hazard with a low level of risk which, if not avoided, could result in minor or moderate injury.
Warning	Warning indicates a hazard with a medium level of risk which, if not avoided, could result in death or serious injury.
Danger	Danger indicates a hazard with a high level of risk which, if not avoided, will result in death or serious injury.

Warning

- Always ensure compliance with relevant safety laws and standards.**
- All work must be carried out in a safe manner by a qualified person in compliance with applicable national regulations.
- This product is class A equipment intended for use in an industrial environment. There may be potential difficulties in ensuring electromagnetic compatibility in other environments due to conducted or radiated disturbances.
- Refer to the operation manual on the SMC website (URL: <https://www.smcworld.com>) for more safety instructions.

2 Specifications

2.1 General specifications

Item	Specifications
Enclosure	IP40
Operating temperature	Operating: 0 to 50 °C; Storage: -10 to 60 °C (no freezing or condensation)
Humidity range	35 to 85% R.H. (no condensation)
Withstand voltage	1000 VAC for 1 min. between charged part and case
Insulation resistance	50 MΩ min (500 VDC Mega) between charged part and case
Materials in contact with fluid	LCP, PBT, brass (electroless nickel plating), HNBR (+ fluoro coating), FKM (+ fluoro coating), Si, Au, SUS304

2 Specifications (continued)

2.2 Specifications

Model	PFM710	PFM725	PFM750	PFM711		
Applicable fluid	Dry air, N ₂ , Ar, CO ₂ (air quality class to ISO8573-1 1.1.2 to 1.6.2)					
Rated flow range (L/min)	Dry air, N ₂ , Ar	0.2 to 10	0.5 to 25	1 to 50	2 to 100	
	CO ₂	0.2 to 5	0.5 to 12.5	1 to 25	2 to 50	
Instantaneous flow	Display flow range (L/min)	Dry air, N ₂ , Ar	0.2 to 10.5	0.5 to 26.3	1 to 52.5	2 to 105
		CO ₂	0.2 to 5.2	0.5 to 13.1	1 to 26.2	2 to 52
	Set flow range (L/min)	Dry air, N ₂ , Ar	0 to 10.5	0 to 26.3	0 to 52.5	0 to 105
		CO ₂	0 to 5.2	0 to 13.1	0 to 26.2	0 to 52
Accumulated flow	Setting / display unit (L/min)	0.01 min. / 0.1 min.				
	Setting / display flow range	0 to 999999 L				
	Minimum Setting / display unit	1 L				
	Accumulated flow volume / pulse	0.1 L/pulse		1 L/pulse		
Display unit	Instantaneous flow: L/min, CFM x 10 ⁻² Accumulated flow: L, ft ³ x 10 ⁻¹					
Reference condition	Standard condition (ANR), Normal condition (NOR)					
Repeatability	±1% F.S. max. (fluid: Dry air) Analogue output accuracy: ±3% F.S. max.					
Pressure characteristics	±5% F.S. max. (0.35 MPa reference)					
Temperature characteristics	±2% F.S. max. (15 to 35 °C) ±5% F.S. max. (0 to 15 °C, 35 to 50 °C)					
Rated pressure range	-70 to 750 kPa					
Proof pressure	1 MPa					
Switch output	NPN or PNP open collector output					
Analogue output	Max. load current	80 mA				
	Max. load voltage	28 VDC (NPN output)				
	Internal voltage drop	NPN output: 1 V (at 80 mA), PNP output: 1.5 V or less (at 80 mA)				
	Response time	1 s (50 ms, 0.5 s, 2 s selectable)				
	Output protection	Short circuit protection				
	Output mode	Hysteresis mode, Window comparator mode, Accumulated output mode, Accumulated pulse output mode				
	Hysteresis	Variable				
	Response time	1.5 s				
	Voltage output	Output voltage: 1 to 5 V Output impedance: 1 kΩ				
	Current output	Output current: 4 to 20 mA Max. load impedance: 600 Ω (24 VDC) Min. load impedance: 50 Ω				
Accuracy	±5% F.S. max.					
External input	Voltage free input (reed or solid-state switch), 30 ms or more					
Display accuracy	±3% F.S. max. (fluid: Dry air)					
Display	3 digits, 7 segment, dual colour (red/green)					
Indicator LED	LED is ON when output is ON OUT1: Green, OUT2: Red					
Supply voltage	24 VDC ±10%					
Power consumption	55 mA					

2 Specifications (continued)

2.3 Piping Port and Weight specifications

Model	01	02	N01	N02	F01	F02	C4 *	C6 *	C8 *	N7 *
Thread (Port size)	Rc 1/8	Rc 1/4	NPT 1/8	NPT 1/4	G 1/8	G 1/4	φ4 (5/32")	φ6	φ8 (5/16")	φ1/4
Weight	Straight		95 g (without flow adjustment valve)		125 g		55 g			
	Bottom entry		105 g (without flow adjustment valve)		135 g		65 g			
	Straight		135 g (with flow adjustment valve)		165 g		95 g			
	Bottom entry		145 g (with flow adjustment valve)		175 g		105 g			

* Indicates one touch fitting.

2.4 Cable specifications

Conductor	Nominal cross section	AWG26
	Individual wire diameter	approx. 0.50 mm
Insulator	Outside diameter	approx. 1.00 mm
	Colours	Brown, White, Black, Blue
Sheath	Material	Lead free heat and oil resistant PVC
	Outer diameter	approx. φ3.5 mm

Warning

- Special products (-X) might have specifications different from those shown in this section. Contact SMC for specific drawings.

2.5 Analogue Output characteristics

*: Analogue output at maximum rated flow rate when CO₂ is selected is 3 [V] for the voltage output type and 12 [mA] for the current output type.

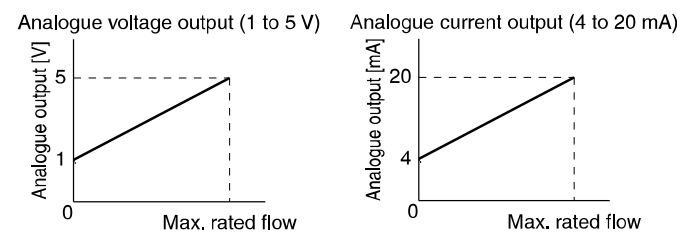

Model	Max. rated flow (L/min)	Model	Max. rated flow (L/min)
PFM710-#-C/E	10 (5)	PFM710-#-D/F	10 (5)
PFM725-#-C/E	25 (12.5)	PFM725-#-D/F	25 (12.5)
PFM750-#-C/E	50 (25)	PFM750-#-D/F	50 (25)
PFM711-#-C/E	100 (50)	PFM711-#-D/F	100 (50)

*: Values for CO₂ shown in brackets ().

3 Name and function of parts

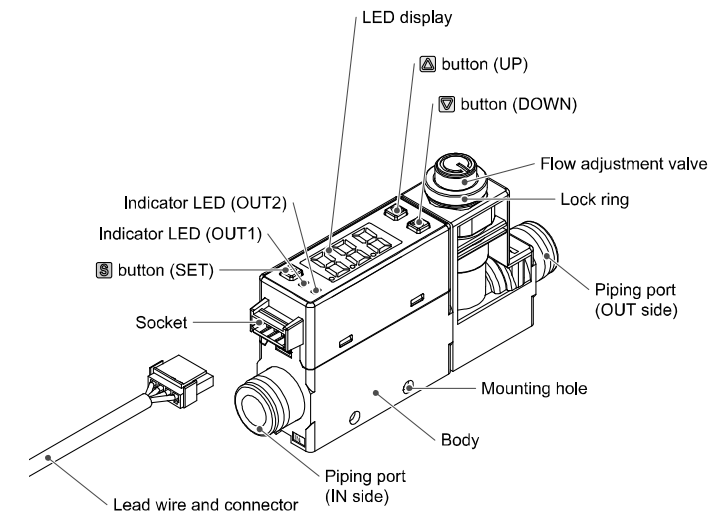

Item	Description
Indicator LED (OUT1)	Indicates the output status of OUT1. LED is ON (Green) when OUT1 is ON. When the accumulated pulse output mode is selected, the indicator LED will turn OFF.
Indicator LED (OUT2)	Indicates the output status of OUT2. LED is ON (Red) when OUT2 is ON. When the accumulated pulse output mode is selected, the indicator LED will turn OFF.
SET button	Press this button to change to another mode and to set a value.
Socket	Socket for electrical connections.
Piping port	Connected to the fluid inlet at IN side and to the fluid outlet at OUT side.
LED display	Displays the flow value, setting mode, and error indication. Four display modes can be selected: display always in red or green, or display changing from green to red, or red to green, according to the output status (OUT1).
UP button	Selects the mode or increases the ON/OFF set value. Press this button to change to the peak display mode.
DOWN button	Selects the mode or decreases the ON/OFF set value. Press this button to change to the bottom display mode.
Flow adjustment valve	Orifice mechanism to adjust the flow.
Lock ring	Used to lock the flow adjustment valve.
Mounting hole	Used to mount the product on a DIN rail or directly to a panel.
Body	The body of the product.
Lead wire and connector	Lead wire to supply power and transmit output signals.

*: The table shows the specifications when a flow adjusting valve is included.

4 Installation

4.1 Installation

Warning

- Do not install the product unless the safety instructions have been read and understood.
- Use the product within the specified operating rated flow, operating pressure and temperature range.
- Tighten to the specified tightening torque. If the tightening torque is exceeded the mounting screws, brackets and the product can be broken. Insufficient torque can cause displacement of the product from its correct position.
- Do not drop, hit or apply excessive shock to the product.

4 Installation (continued)

4.2 Environment

Warning

- Do not use in an environment where corrosive gases, chemicals, salt water or steam are present.
- Do not use in an explosive atmosphere.
- Do not expose to direct sunlight. Use a suitable protective cover.
- Do not install in a location subject to vibration or impact in excess of the product's specifications.
- Do not mount in a location exposed to radiant heat that would result in temperatures in excess of the product's specifications.

4.3 Mounting

- Never mount the product in a location that will be used as a foothold.
- Mount the product so that the fluid flows in the direction indicated by the arrow on the body.

4.3.1 Panel mounting

- Insert Panel Mount Adapter B (supplied as an accessory) into Section A of Panel Mount Adapter A. Push Panel Mount Adapter B from behind until the display is located in the panel.
- The pin of Panel Mount Adapter B engages the notched part of Panel Adapter section C to fix the display.
- The switch can be mounted on a panel with a thickness of 1 to 3.2 mm.

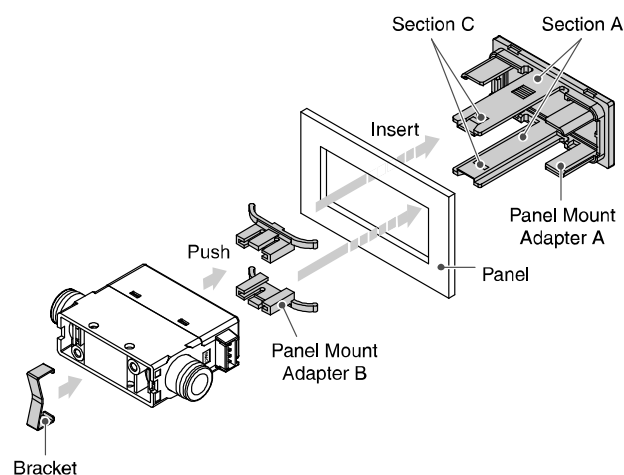

4.3.2 Bracket mounting

- Mount the bracket (Part No. ZS-36-A1) on to the product using the mounting screws supplied.
- The required tightening torque is 0.5 ± 0.05 N•m.

Without Flow adjustment valve
(using Part No. ZS-33-M)

With Flow adjustment valve
(using Part No. ZS-33-MS)

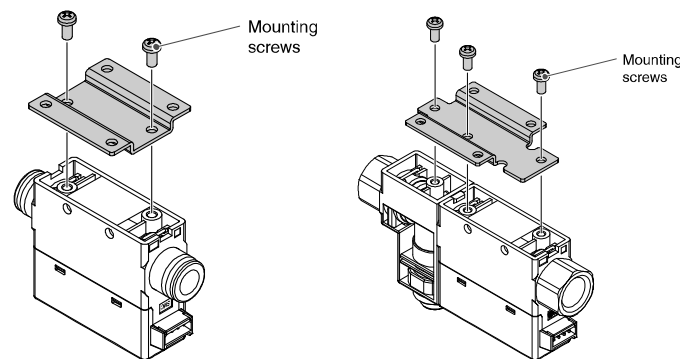

- Install the product (with bracket) using M3 screws (4 pcs.).
- Bracket thickness is approximately 1.2 mm.

Refer to the operation manual on the SMC website (URL: <https://www.smworld.com>) for mounting hole dimensions.

4 Installation (continued)

4.3.3 DIN rail mounting

- Mount the DIN rail brackets (Part No. ZS-33-R#) to the product using the mounting screws and joint screws supplied.
- The required tightening torque for both screw types is 0.4 ± 0.05 N•m.

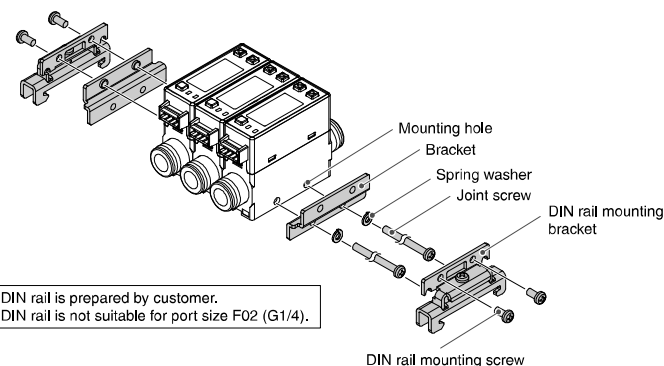

4.4 Piping

Caution

- Before connecting piping make sure to clean up chips, cutting oil, dust etc.
- When installing piping or fittings, ensure sealant material (tape) does not enter inside the port.
- When connecting the piping, hold the specified part of the body with a spanner. Using a spanner on other parts may damage the product.
- The required tightening torque of the fittings is given in the table below. If the tightening torque is exceeded, the product can be damaged. If the correct tightening torque is not applied, the fittings may become loose.
- Ensure there is no leakage after piping.

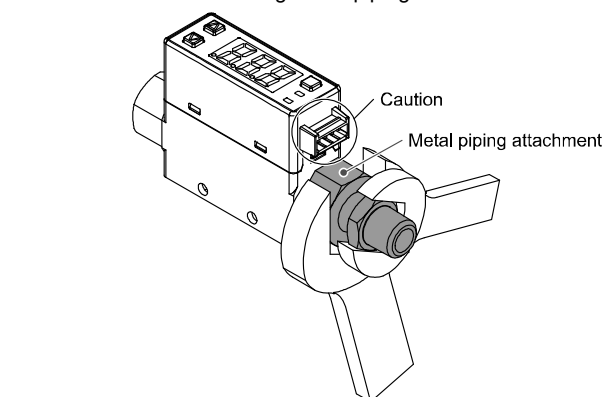

Nominal Thread size	Width across flats of attachment	Tightening torque
Rc (NPT) 1/8, G1/8	17 mm	7 to 9 N•m
Rc (NPT) 1/4	21 mm	12 to 14 N•m

4.4.1 One Touch fittings

- Insert the tube until it bottoms out, to ensure it cannot be pulled out.
- Insertion with excessive force can cause damage.
- Ensure that there is no leakage after piping.
- Use the product within the specified operating pressure and temperature ranges.
- Proof pressure is 1.0 MPa.

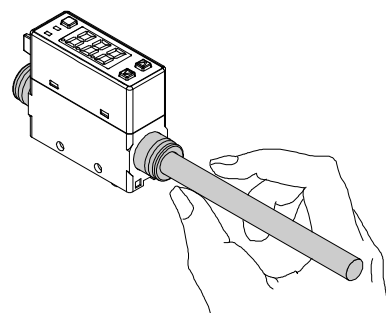

5 Wiring

5.1 Wiring

Caution

- Wiring should only be performed with the power supply turned OFF.
- Confirm proper insulation of wiring.
- Use separate routes for the product wiring and any power or high voltage wiring. Otherwise, malfunction may result due to noise.
- Keep wiring as short as possible to prevent interference from electromagnetic noise and surge voltage.
- Ensure that the FG terminal is connected to ground when using a commercially available switch-mode power supply. Switching noise will be superimposed and the product specification can no longer be met. This can be prevented by inserting a noise filter, such as a line noise filter and ferrite core, between the switch-mode power supply and the product, or by using a series power supply instead of a switch-mode power supply.

5.1.1 Connecting/Disconnecting

- When mounting the connector, insert it straight into the socket, holding the lever and connector body, and push the connector until the lever hooks into the housing, and locks.
- When removing the connector, press down the lever to release the hook from the housing and pull the connector straight out.

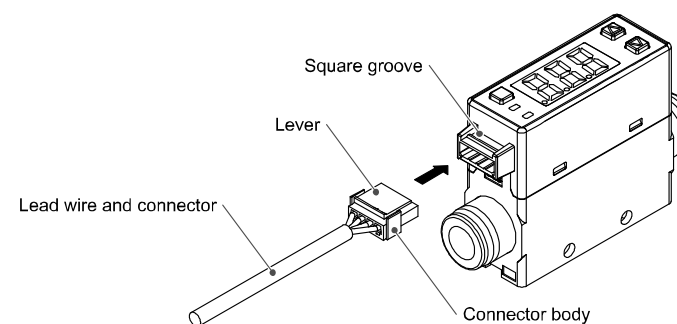

5.1.2 Connector pin numbers (on the lead wire)

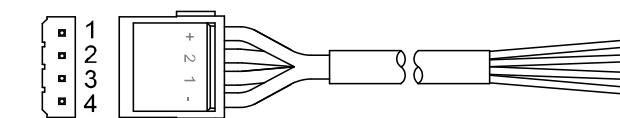

Pin No.	Wire colour	Signal
1	Brown	DC (+)
2	White	OUT2 / Analogue output/External input
3	Black	OUT1
4	Blue	DC (-)

6 Flow Setting

6.1 Measurement mode

- Measurement mode is the mode in which the flow is detected and displayed, and the switch function is operating.
- This is the basic operating mode; other modes should be selected for set-point and other Function Setting changes.

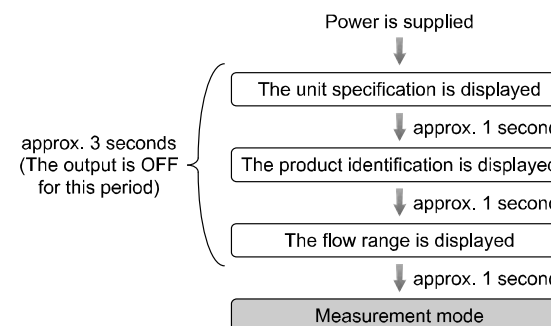

6 Flow Setting (continued)

6.2 Switch operation

- When the flow exceeds the set value, the switch will turn ON.
- When the flow falls below the set value by the amount of hysteresis or more, the switch will turn OFF.
- If this condition, shown to the right, is acceptable, then keep these settings.

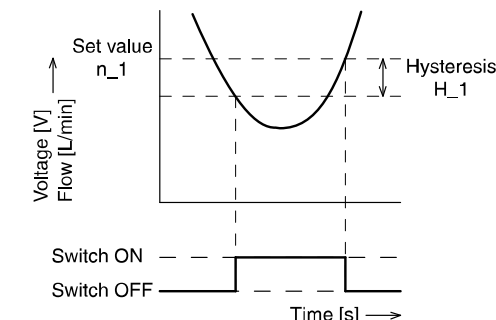

<Operation>

*: The Product outputs will continue operating during setting.

- Press the SET button in measurement mode to display the set values.

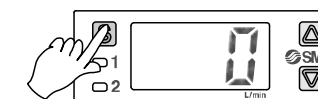

[P_1] or [n_1] and the set value are displayed in turn.



- Press the UP or DOWN button to change the set value.

The UP button is to increase and the DOWN button to decrease the set value. Press the UP button once to increase by one digit or press it continuously to keep increasing the set value.



Press the DOWN button once to decrease by one digit or press it continuously to keep decreasing the set value.

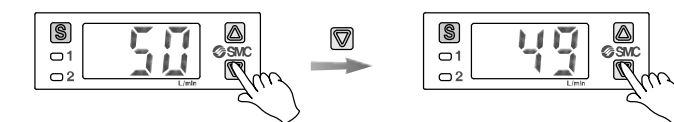

- Press the SET button to finish the setting of OUT1.

For models with 2 outputs, [P_2] or [n_2] will be displayed. Set OUT2 as above.

- Zero clear of display
The display is reset to zero when UP and DOWN are pressed simultaneously for 1 second.
For the initial operation, always perform zero clear with no flow applied.

7 Function Setting

7.1 Function selection mode

In measurement mode, press the SET button for 2 seconds or longer to display [F 0].

The [F##] indicates the mode for changing each function setting.

Press the SET button for 2 seconds or longer in function selection mode to return to measurement mode.

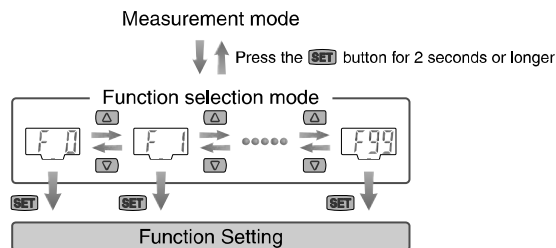

Item	Default setting
[F 0] [Uni] Unit selection function	[L] L/min
[oU1] Output mode (OUT1)	[HYS] Hysteresis mode
[1ot] Reversed output (OUT1)	[1_P] Normal output
[P_1] Input Set value (OUT1)	[] 50% of max. rated flow PFM710: 5 L/min, PFM725: 12.5 L/min PFM750: 25 L/min, PFM711: 50 L/min
[H_1] Hysteresis Setting (OUT1)	[] 3% of max. rated flow PFM710: 0.3 L/min, PFM725: 0.8 L/min PFM750: 1.5 L/min, PFM711: 3 L/min
[CoL] Display colour	[SoG] ON: Green, OFF: Red
[F 2] [oU2] Output mode (OUT2)	[HYS] Hysteresis mode
[2ot] Reversed output (OUT2)	[2_P] Normal output
[P_2] Input Set value (OUT2)	[] 50% of max. rated flow PFM710: 5 L/min, PFM725: 12.5 L/min PFM750: 25 L/min, PFM711: 50 L/min
[H_2] Hysteresis Setting (OUT2)	[] 3% of max. rated flow PFM710: 0.3 L/min, PFM725: 0.8 L/min PFM750: 1.5 L/min, PFM711: 3 L/min
[F 3] [FLU] Operating fluid	[A i r] dry air, N ₂
[F 4] [rEF] Reference condition	[A n r] Standard condition
[F 5] [eES] Response time	[1.00] 1 second
[F 6] [dSP] Display mode	[i n S] Instantaneous flow
[F 7] [inP] External input	[r_r] Accumulated flow external reset
[F 8] [drE] Display resolution	[1E2] 100-split
[F 9] [PrS] Auto-preset	[oFF] Manual
[F10] [EEP] Accumulated hold	[oFF] OFF
[F11] [AFL] Analogue output filter	[on] With filter
[F12] [Eco] Power saving mode	[oFF] Unused
[F13] [Pin] Security code	[oFF] Unused
[F98] [ALL] Setting of all functions	[oFF] Unused
[F99] [ini] Reset to default settings	[oFF] Unused

8 Other Functions

- Peak / Bottom hold function
- Zero clear function
- Key-lock function

Refer to the operation manual on the SMC website (URL: <https://www.smcworld.com>) for setting these functions.

9 How to Order

Refer to the operation manual or catalogue on the SMC website (URL: <https://www.smcworld.com>) for How to order information.

10 Outline Dimensions (mm)

Refer to the operation manual or catalogue on the SMC website (URL: <https://www.smcworld.com>) for Outline Dimensions.

11 Maintenance

11.1 General Maintenance

Caution

- Not following proper maintenance procedures could cause the product to malfunction and lead to equipment damage.
- If handled improperly, compressed air can be dangerous.
- Maintenance of pneumatic systems should be performed only by qualified personnel.
- Before performing maintenance, turn off the power supply and be sure to cut off the supply pressure. Confirm that the air is released to atmosphere.
- After installation and maintenance, apply operating pressure and power to the equipment and perform appropriate functional and leakage tests to make sure the equipment is installed correctly.
- If any electrical connections are disturbed during maintenance, ensure they are reconnected correctly and safety checks are carried out as required to ensure continued compliance with applicable national regulations.
- Do not make any modification to the product.
- Do not disassemble the product, unless required by installation or maintenance instructions.

How to reset the product after a power cut or when the power has been unexpectedly removed

The settings of the product are retained from before the power cut or de-energizing.

The output condition also recovers to that before the power cut or de-energizing, but may change depending on the operating environment. Therefore, check the safety of the whole system before operating the product.

12 Limitations of Use

12.1 Limited warranty and Disclaimer/Compliance Requirements

Refer to Handling Precautions for SMC Products.

13 Product disposal

This product should not be disposed of as municipal waste. Check your local regulations and guidelines to dispose of this product correctly, in order to reduce the impact on human health and the environment.

14 Contacts

Refer to www.smcworld.com or www.smc.eu for your local distributor / importer.

SMC Corporation

URL: <https://www.smcworld.com> (Global) <https://www.smceu.com> (Europe)
SMC Corporation, 4-14-1, Sotokanda, Chiyoda-ku, Tokyo 101-0021, Japan
Specifications are subject to change without prior notice from the manufacturer.
© 2021 SMC Corporation All Rights Reserved.
Template DKP50047-F-085M