



ORIGINAL INSTRUCTIONS

Instruction Manual

Zero pressure differential type pilot operated 2 port solenoid valve

Series VXS

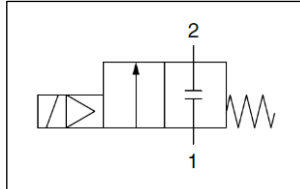

The intended use of this valve is to control the flow of heated water and steam for downstream pressurised systems.

1 Safety Instructions

Be sure to read the "Handling Precautions for SMC Products", "Product Catalogue" and the "Operation Manual" on the SMC website before handling this product:

<https://www.smcworld.com/pl/en-jp> <https://www.smc.eu/en-eu/safety-instructions>

These safety instructions are intended to prevent hazardous situations and/or equipment damage. These instructions indicate the level of potential hazard with the labels of "Caution," "Warning" or "Danger." They are all important notes for safety and must be followed in addition to International Standards (ISO/IEC), and other safety regulations.

| | |
|----------------|--|
| Danger | Danger indicates a hazard with a high level of risk which, if not avoided, will result in death or serious injury. |
| Warning | Warning indicates a hazard with a medium level of risk which, if not avoided, could result in death or serious injury. |
| Caution | Caution indicates a hazard with a low level of risk which, if not avoided, could result in minor or moderate injury. |

Warning

- Always ensure compliance with relevant safety laws and standards.
- All work must be carried out in a safe manner by a qualified person in compliance with applicable national regulations.
- If this equipment is used in a manner not specified by the manufacturer, the protection provided by the equipment may be impaired.

Caution

- The product is provided for use in manufacturing industries only. This product must not be used in residential areas.

2 Specifications

2.1 Valve specifications

| | |
|---|--|
| Valve type | Normally closed (N.C.) |
| Valve construction | Zero differential pressure pilot operated 2 port piston type |
| Fluid | Steam, Heated water |
| Maximum system pressure [MPa] | 1.0 |
| Withstand pressure [MPa] | 2.0 |
| Operating pressure differential range [MPa] | 0 to 1.0 ^{Note 1)} |
| Orifice Ø [mm] | 10, 15, 20, 25 |
| Ambient temperature [°C] | -20 to 60 (no freezing) |
| Fluid temperature [°C] | Steam: 183 or less Heated water: 99 or less |
| Flow characteristics | Refer to table 3 |
| Min. operating frequency | 1 cycle / 30 days |
| Manual override | None |
| Lubrication | Not required |
| Impact/Vibration resistance [m/s ²] | 150/30 ^{Note 2)} |
| Enclosure (based on IEC60529) | IP65 |
| Mounting orientation | Restricted (see 3.6 Mounting) |
| Body material | C37 (Brass), Stainless steel |

2 Specifications – continued

| | |
|---------------|------------------|
| Seal material | FKM |
| Weight | Refer to table 3 |

Table 1.

Note 1) The operation of the valve may be unstable due to the capacity of the pressure supply source such as pumps and boilers or the pressure loss by the orifice of piping.

Note 2) Impact resistance: No malfunction occurred when it was tested in the axial direction and at right angles to the main valve and armature; in both energized and de-energised states and for every time in each condition. (Values quoted are for a new valve)

Vibration resistance: No malfunction occurred in a one-sweep test between 5 and 200 Hz. Tests are performed at both energized and de-energized states in the axial direction and at right angles to the main valve and armature. (Values quoted are for a new valve).

2.2 Solenoid specifications

| | VXS23/24 | VXS25/26 |
|--|--|--|
| Coil rated voltage | DC [VDC] | 24 |
| | AC [VAC] | 100, 200, 110, 230 (220, 240, 48, 24) ^{Note 1)} |
| Electrical entry | Grommet, DIN terminal, Conduit terminal, Conduit | |
| Coil insulation class | Class H | |
| Allowable voltage fluctuation ^{Note 2)} | ±10% of rated voltage | |
| Apparent power [VA] | 12 | 15 |
| Power consumption [W] | 12 | 15 |
| Temperature rise [°C] | 100 | |
| Allowable leakage voltage | AC | 5% or less of rated voltage |
| | DC | 2% or less of rated voltage |
| Surge voltage suppressor | Varistor | |

Table 2.

Note 1) Voltage in brackets () indicates special voltage.

Note 2) Valve state is not defined if electrical input is outside of specified operating ranges.

2.3 Model/Valve specifications

| Size | Port Size | Orifice Dia. [mm] | Model | Flow characteristics | | Weight ^{Note)} [g] |
|------|-----------|-------------------|--------|----------------------|-----|-----------------------------|
| | | | | Kv | Cv | |
| 3 | 1/4 | 10 | VXS235 | 2.1 | 2.4 | 600 |
| | 3/8 | | | 2.4 | 2.8 | |

| | | | | | | |
|---|-----|----|--------|------|------|------|
| 4 | 1/2 | 15 | VXS245 | 4.6 | 5.3 | 720 |
| 5 | 3/4 | 20 | VXS255 | 7.9 | 9.2 | 1100 |
| 6 | 1 | 25 | VXS265 | 10.4 | 12.0 | 1300 |

Table 3.

Note) Weight of Grommet type. Add 10g for Conduit type, 30g for DIN terminal, 60g for Conduit terminal type.

Valve internal and external leakage rate

| Fluid | Leakage rate ^{Note)} |
|--------------|----------------------------------|
| Steam | 1 cm ³ /min or less |
| Heated water | 0.1 cm ³ /min or less |

Table 4.

Note) Leakage is the value at ambient temperature 20°C.

3 Installation

3.1 Installation

Warning

- Do not install the product unless the safety instructions have been read and understood.

3.2 Environment

Warning

- Do not use in an environment where corrosive gases, chemicals, salt water, water, or steam is present.
- Do not use in an explosive atmosphere.
- Do not expose to direct sunlight. Use a suitable protective cover.
- Do not install in a location subject to vibration or impact exceeding the product's specifications.
- Do not mount in a location exposed to radiant heat that would result in temperatures exceeding the product's specifications.
- Employ suitable protective measures in locations where there is contact with water droplets, oil or welding splatter, etc.
- Products compliant with IP65 enclosures are protected against dust and water, however, these products cannot be used in water.

3 Installation – continued

- Products compliant with IP65 enclosures satisfy the specifications by mounting each product properly. Be sure to read the Specific Product Precautions for each product.
- Do not use in high humidity environment where condensation can occur.

3.2 Piping

Caution

- Before connecting piping, it should be thoroughly blown out with air (flushed) or washed to remove chips, cutting oil and other debris from inside the pipe. Avoid pulling, compressing, or bending the valve body when piping.
- Avoid connecting ground lines to piping, as this may cause electrolytic corrosion of the system.
- When installing piping or fittings, ensure sealant material does not enter inside the port. When using seal tape, leave sufficient space at the end of the thread to ensure that sealing tape does not enter the product.
- Tighten fittings to the specified tightening torque, see table 5.
- Install piping so that it does not apply pulling, pressing, bending or other forces on the valve body.
- When connecting piping, avoid mistakes regarding the supply port.
- Steam generated by a boiler contains a large amount of drainage; ensure to operate with a drain trap installed.
- Avoid installing piping to the valve at the lowest point of the layout. If condensate accumulates in the valve or adjacent piping, this could cause steam hammer. If steam hammer causes a problem, install a bypass to discharge condensate from the piping.
- If the effective area of the piping on the fluid supply side is restricted, the operating time may become unstable due to the differential pressure fluctuation when the valve is closed.
- For the convenience of maintenance and repair, install a bypass circuit and use a union for piping.
- To control the fluid in the tank, connect the piping a little higher than the bottom of the tank.
- If using SMC fittings refer to the fittings catalogue for the specified tightening torque.
- Follow the manufacturer's instructions if using fittings other than SMC.

- If using metal piping, tighten to the specified tightening torque.

| Model | Thread | Tightening torque [N·m] |
|-------|--------|-------------------------|
| VXS23 | 1/4 | 8 to 12 |
| | 3/8 | 15 to 20 |
| VXS24 | 1/2 | 20 to 25 |
| VXS25 | 3/4 | 28 to 30 |
| VXS26 | 1 | 36 to 38 |

Table 5.

3.3 Lubrication

Caution

- SMC products have been lubricated for life at manufacture, and do not require lubrication in service.
- If a lubricant is used in the system, refer to catalogue for details.

3.4 Fluid supply

Warning

- The use of a fluid that contains foreign matter can cause problems, such as malfunction and seal failure by promoting the wear of the valve seat and armature, by sticking to the sliding parts of the armature, etc.
- Install a suitable filter (strainer) immediately upstream of the valve.
- As a general rule, use 100 mesh for water.
- As a standard, the mesh count for the strainer is 100 mesh. However, the size and shape of foreign objects that occur depends on the operating environment. Check the fluid status and choose an appropriate mesh count.

3.4.1 Steam, Water

Warning

- Be aware that rust stains, chloride separation, etc., from the piping may cause malfunction, leakage, or, in worse case scenarios, damage due to corrosion. Also, such damage may result in the spraying of fluids or scattering of parts. Please be sure to have protective measures in place in case such incidents should occur.

3 Installation – continued

- In the case that water contains substances such as calcium and magnesium, which generate hard scale and sludge, install water softening equipment and a filter (strainer) directly upstream from the valve to remove these substances, as this scale and sludge can cause the valve to malfunction.
- The water pressure of tap water is usually 0.4 MPa or less, but the pressure can sometimes increase to 1.0 MPa in tall buildings. Therefore, pay attention to the max. operating pressure differential.
- Do not use operation steam which contains chemicals, synthetic oils containing organic solvents, salts or corrosive gases etc., as these can cause damage or deterioration.
- The seal material (special FKM) used for wetted parts of the product can withstand steam in standard conditions. However, the resistance of the sealing material can deteriorate depending on the types of additives such as boiler compounds and water conditioners within the boiler steam. Please only utilize the product after determining the sealing material resistance within the actual usage conditions.

3.5 Mounting

Warning

- Do not install with the coil downwards. If a valve is mounted with the coil positioned downwards, foreign objects in the fluid will adhere to the core/armature leading to a malfunction.
- Secure with brackets, except in the case of steel piping and copper fittings.
- Avoid sources of vibration or adjust the distance from the body to a minimum length so that resonance will not occur.
- If air leakage increases or equipment does not operate properly, stop operation. After mounting is completed, confirm that it has been done correctly by performing a suitable function test.
- Do not apply external force to the coil section: When tightening fittings, apply a wrench or other tool to the outside of the piping connection parts.
- Do not warm the coil assembly with a heat insulator, etc. Use tape, heaters, etc., for freeze prevention on the piping and body only. They can cause the coil to burn out.
- Painting and coating. Warnings or specifications printed or labelled on the product should not be erased, removed or covered up.

3.5.1 Bracket mounting

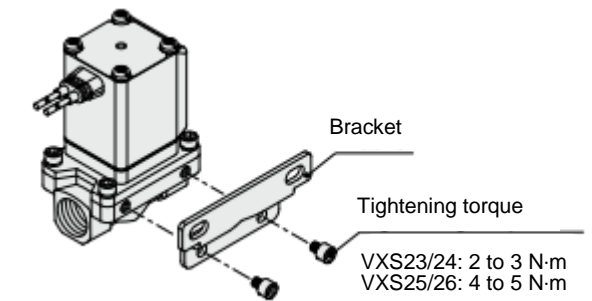

Figure 1.

3.6 Electrical circuits

Caution

Surge suppression should be specified by using the appropriate part number. If a valve type without suppression (Type 'A') is used, suppression must be provided by the host controller as close as possible to the valve.

3 Installation – continued

3.6.1 DC circuit

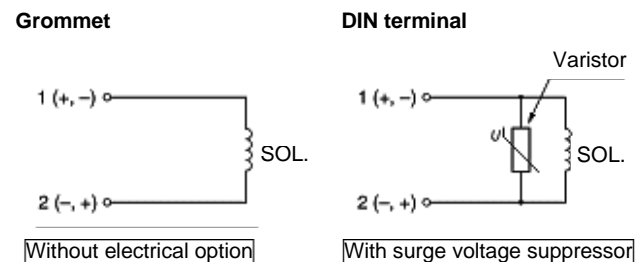
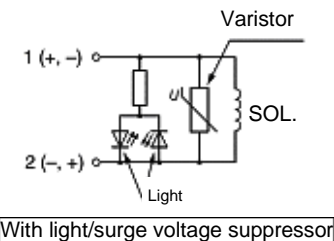

Figure 2.

DIN terminal, Conduit terminal



3.6.2 AC circuit

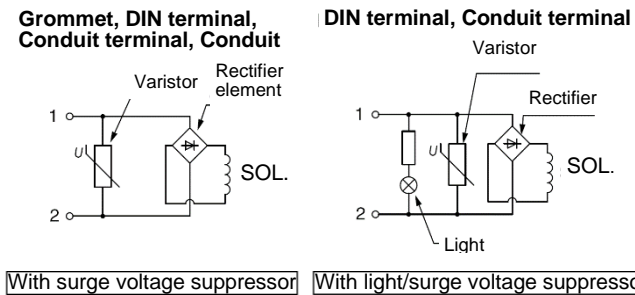

Figure 3.

DIN terminal H type with AC voltage has full-wave rectifier built in the DIN connector. Coil does not have full-wave rectifier.

3.7 Electrical connectors

Caution

- When a surge from the solenoid affects the electrical circuitry, install a surge absorber, etc., in parallel with the solenoid. Or, use an option that comes with surge voltage protection circuit.
- Use electrical circuits that do not generate chattering in their contacts.
- Use voltage that is within ±10% of the rated voltage. In cases with a DC power supply where responsiveness is important, stay within ±5% of the rated value. (The voltage drop is the value in the lead wire section connecting the coil).
- Generally use electrical wire with cross sectional area 0.5 to 1.25 mm².
- Do not bend or pull cables repeatedly.
- Do not allow excessive force to be applied to the lines.
- Do not apply AC voltage to AC type unless it has a built in full-wave rectifier or it will be damaged.

3.7.1 Grommet

Class H coil: AWG18 Outside insulator diameter of 2.1 mm.

3 Installation – continued

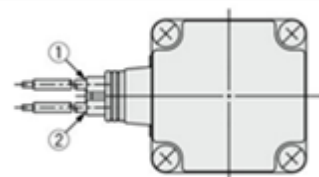

Figure 4.

| Rated Voltage | Lead wire colour | |
|---------------|------------------|------|
| | 1 | 2 |
| DC | Black | Red |
| 100 VAC | Blue | Blue |
| 200 VAC | Red | Red |
| Other AC | Grey | Grey |

Table 6.

*There is no polarity

3.7.2 DIN terminal

- Tighten the screw to a torque of between 0.5 and 0.6 N·m.
- Cable O.D.: ø6 to ø12 mm
- For an outside cable diameter of ø9 to 12 mm, remove the internal parts of the rubber seal before using.
- The orientation of the connector can be changed in steps of 90° by changing the method of assembling the housing and the terminal block.

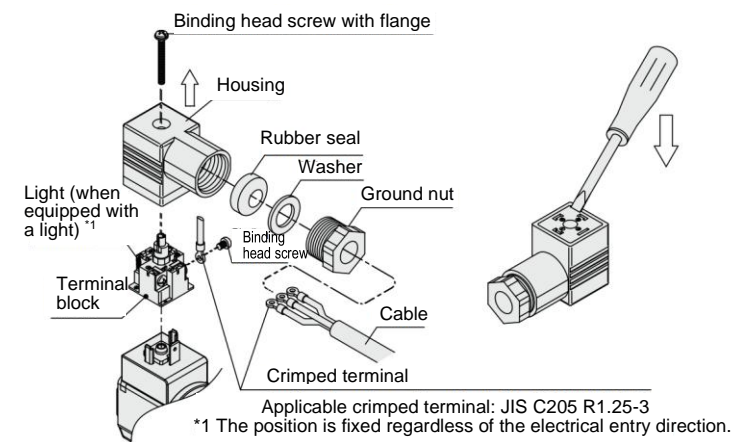

Figure 5.

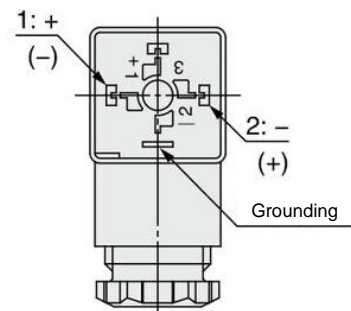

Figure 6.

| Terminal no. | 1 | 2 |
|--------------|------|------|
| Din Terminal | +(-) | -(+) |

Table 7

*There is no polarity

3 Installation – continued

3.7.3 DIN (EN175301-803) Terminal

This DIN terminal corresponds to the Form A DIN connector with an 18 mm terminal pitch, which complies with EN175301-803B.

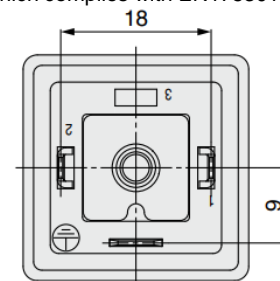

Figure 7.

Caution

- For class H coil, surge voltage suppressor and full-wave rectifier (for AC) are on DIN connector side. A SMC DIN connector must be used. Part numbers can be found in product catalogue.

Warning

- The ground terminal is connected to the coil assembly only and does not provide a protective earth for the body of the valve.

3.7.4 Conduit terminal

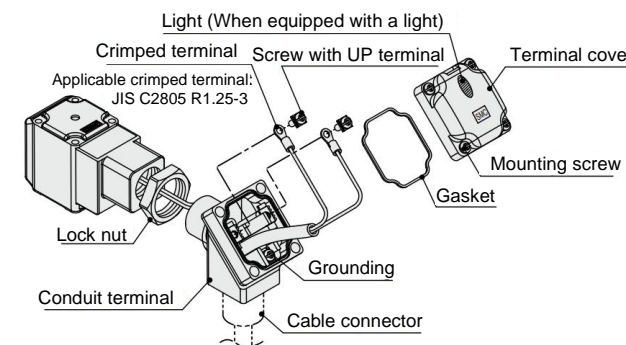

Figure 8.

- Make connections according to the marking shown in Figure 9.
- Tighten screws and fittings according to Figure 9.

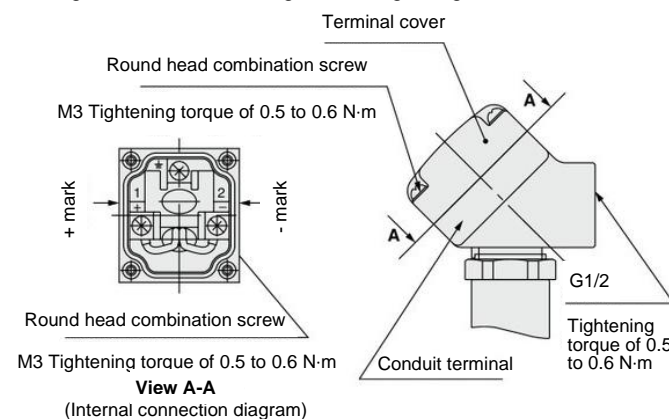

Figure 9.

- Properly seal the terminal connection (G1/2) with special wiring conduit, etc.

3 Installation – continued

3.7.5 Conduit

- When used as an IP65 equivalent use seal (VCW20-15-6) to install the wiring conduit.
- Tighten conduit to torque shown in Figure 10.
Class H coil: AWG18 Outside insulator diameter of 2.1 mm

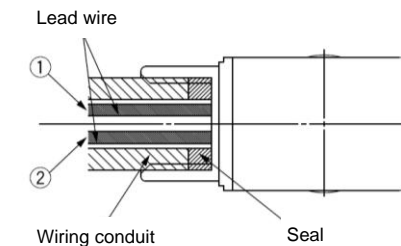

(Connection G1/2 Tightening torque of 0.5 to 0.6 N·m)

Figure 10.

| Rated Voltage | Lead wire colour | |
|---------------|------------------|------|
| | 1 | 2 |
| DC | Black | Red |
| 100 VAC | Blue | Blue |
| 200 VAC | Red | Red |
| Other AC | Grey | Grey |

Table 8.

*There is no polarity
(For the power saving type, there is polarity)

3.8 Residual voltage

Caution

- If a Zener diode or varistor voltage suppressor is used, the suppressor arrests the back EMF voltage from the coil to a level in proportion to the rated voltage.
- Ensure the transient voltage is within the specification of the host controller.

3.9 Countermeasure for surge voltage

Caution

- At times of sudden interruption of the power supply, the energy stored in a large inductive device may cause non-polar type valves in a de-energised state to switch.
- When installing a breaker circuit to isolate the power, consider a valve with polarity (with polarity protection diode), or install a surge absorption diode across the output of the breaker.

3.10 Extended period of continuous energization

Warning

- The solenoid coil will generate heat when continuously energized so avoid installing in an enclosed space. Install the valve in a well-ventilated area.
- Do not touch the coil while it is being energized or immediately after energization.

4 How to Order

Refer to catalogue for 'How to Order'.

5 Outline Dimensions

Refer to catalogue for outline dimensions.

6 Maintenance

6.1 General maintenance

Caution

- Not following proper maintenance procedures could cause the product to malfunction and lead to equipment damage.
- If handled improperly, compressed air can be dangerous.
- Maintenance of pneumatic systems should be performed only by qualified personnel.
- Before performing maintenance, turn off the power supply and be sure to cut off the supply pressure. Confirm that the air is released to atmosphere.
- After installation and maintenance, apply operating pressure and power to the equipment, and perform appropriate functional and leakage tests to ensure the equipment is installed correctly.

6 Maintenance – continued

- If any electrical connections are disturbed during maintenance, ensure they are reconnected correctly and that safety checks are carried out as required to maintain compliance with applicable national regulations.
- Do not make any modification to the product.
- Do not disassemble the product, unless required by installation or maintenance instructions.
- Exhaust the drainage from the piping periodically.

Warning

6.2 Removing the product

- The valve will reach a high temperature when used with high temperature fluids. Confirm that the valve temperature has dropped sufficiently before performing work. If touched inadvertently, there is danger of being burned.
 1. Shut off the fluid supply and release the fluid pressure in the system.
 2. Shut off the power supply.
 3. Remove the valve, ensuring any seals are retained.

Caution

6.3 Filters and strainers

- Be careful regarding clogging of filters and strainers.
- Replace filter elements after one year of use, or earlier if the pressure drop reaches 0.1 MPa.
- Clean strainers when the pressure drop reaches 0.1MPa.

6.4 Replacement parts

Refer to catalogue for "How to order" of replacement parts such as DIN connector, DIN connector gasket and bracket assembly.

6.5 Storage

In the case of long-term storage, thoroughly remove all moisture to prevent rust and deterioration of rubber materials, etc.

7 Limitations of Use

7.1 Limited warranty and disclaimer/compliance requirements

Refer to Handling Precautions for SMC Products.

Warning

7.2 Effect of energy loss on valve switching

| | |
|---|---|
| Fluid supply present, electrical supply cut | Valve returns to the initial de-energised position by spring force. |
| Electrical supply present, fluid supply cut | Valve remains in the energised position. |

Table 9.

7.3 Low temperature operation

- The valve can be used in an ambient temperature of -20°C. However, take measures to prevent freezing or solidification of impurities, etc.
- When using valves for water application in cold climates, take appropriate countermeasures to prevent the water from freezing in tubing after cutting the water supply from the pump, by draining the water, etc.
- When warming by a heater, etc., be careful not to expose the coil portion to a heater. Installation of a dryer, heat retaining of the body is recommended to prevent freezing condition in which the dew point temperature is high and the ambient temperature is low, and the high flow runs.

7.4 Fluids

- The compatibility of the components of this product with the fluid used may vary depending on the type of fluid, additives, concentration, temperature, etc. Check the compatibility with the actual machine before use.
- Take measures to prevent static electricity since some fluids can cause static electricity.
- Do not use the product with the fluids listed below:
 - Fluids that are harmful to the human body.
 - Combustible or flammable fluids.
 - Corrosive gas and fluid.
 - Sea water, saline.

7 Limitations of Use – continued

7.5 Holding of pressure

Since valves are subject to air leakage, they cannot be used for applications such as holding pressure (including vacuum) in a system.

7.6 Cannot be used as an emergency shut-off valve

This product is not designed for safety applications such as an emergency shut-off valve. If the valves are used in this type of system, other reliable safety assurance measures should be adopted.

7.7 Closed liquid circuit

In a closed circuit, when liquid is static, pressure could rise due to changes in temperature. This pressure rise could cause malfunction and damage to components such as valves. To prevent this, install a relief valve in the system.

7.8 Impact by rapid pressure fluctuation

When problems are caused by a steam hammer, install a steam hammer relief device such as an accumulator. Install water hammer relief equipment (accumulator, etc.), or use a SMC water hammer relief valve (e.g. VXR series).

When an impact, such as steam hammer etc., caused by the rapid pressure fluctuation is applied, the solenoid valve may be damaged.

7.9 Back pressure

If there is a possibility of back pressure being applied to the valve, take countermeasures such as mounting a check valve on the downstream side of the valve.

7.10 Usage with low flow

- Unstable flow may occur under the following conditions:
 - Low flow from the pump or boiler, etc.
 - Use of several elbows or tees in the circuit.
 - Thin nozzles installed at the end of piping, etc.
- These can cause valve opening/closing failure or oscillation and cause a valve malfunction.
- Check the pressure differential and flow to select the appropriate size of valve by referring to the flow rate characteristics. Ensure the pressure differential does not become less than 0.01MPa during ON (N.C.: Valve Open).

Caution

7.11 Leakage voltage

Ensure that any leakage voltage caused by the leakage current when the switching element is OFF causes $\leq 2\%$ (for DC coils) or $\leq 5\%$ (for AC coils) of the rated voltage across the valve.

7.12 Rapid pressure changes

- If used in conditions in which rapid decrease in the inlet pressure and rapid increase in the outlet pressure of the valve are repeated, excessive stress will be applied to the diaphragm, which causes damage to the diaphragm, leading to malfunction of the valve.
- Check the operating conditions before use.

7.13 Sudden inlet pressure increase

- When valve is closed and pressure is applied suddenly due to starting of fluid supply source, such as boiler, the valve may open momentarily, and fluid may leak.

7.14 Low frequency operation:

- Switch valves at least once every 30 days to prevent malfunction. Also, in order to use it under the optimum state, conduct a regular inspection once every 6 months.

7.15 EMC restrictions

7.15.1 Class and group description

- This product is group 1, class A equipment according to EN55011.
- Group 1 equipment does not intentionally generate radio-frequency energy in the range 9kHz to 400 GHz.
- Class A equipment is equipment suitable for use in all locations other than those allocated in residential environments and those directly connected to a low voltage power supply network which supplies buildings used for domestic purposes.
- This equipment is not intended for use in residential environments and may not provide adequate protection to radio reception in such environments.

8 Product Disposal

This product shall not be disposed of as municipal waste. Check your local regulations and guidelines to dispose this of product correctly, in order to reduce the impact on human health and the environment.

9 Return of Product

If the product to be returned is contaminated or is possibly contaminated with substances that are harmful to humans, for safety reasons, please contact SMC beforehand and then employ a specialist cleaning company to decontaminate the product. After the decontamination prescribed above has been carried out, submit a Product Return Request Sheet or the Detoxification/Decontamination Certificate to SMC and await SMC's approval and further instructions before attempting to return the item. Please refer to the International Chemical Safety Cards (ICSC) for a list of harmful substances.

10 Support / Importer / Manufacturer

Support: Please contact your distributor or importer in the country of purchase if you need assistance.

Importer: Address of importer in the country of purchase is listed at <https://www.smc.eu/en-eu/worldwide-addresses>

Manufacturer:

SMC Corporation

URL : <https://www.smcworld.com> (Global) <https://www.smc.eu> (Europe)
SMC Corporation, 1-5-5, Kyobashi, Chuo-ku, Tokyo 104-0031, Japan
Specifications are subject to change without prior notice from the manufacturer.
© SMC Corporation All Rights Reserved.
Template DKP50047-F-085P