



ORIGINAL INSTRUCTIONS

Instruction Manual

Residual pressure relief valve with direct monitoring for use in safety related systems Series VP546/746(-XA###) modular connection type

Note) "###" represent numerical digits.



Safety component as defined by the Machinery Directive 2006/42/EC article 2c/ The Supply of Machinery (safety) Regulations 2008 part 2.4(2)(c).

The intended use of this valve is to vent a protected system to atmosphere when it is de-energised. When properly integrated into a suitable safety system the duplex valves are compatible for use in systems up to Category 4, and the single valves are compatible for use in systems up to Category 2 as defined by EN ISO 13849-1.

1 Safety Instructions

These safety instructions are intended to prevent hazardous situations and/or equipment damage. These instructions indicate the level of potential hazard with the labels of "Caution," "Warning" or "Danger." They are all important notes for safety and must be followed in addition to International Standards (ISO/IEC) (1), and other safety regulations.

- 1) ISO 4414: Pneumatic fluid power - General rules and safety requirements for systems and their components
- ISO 4413: Hydraulic fluid power - General rules and safety requirements

for systems and their components IEC 60204-1: Safety of machinery - Electrical equipment of machines. Part 1: General requirements

ISO 10218-1: Robots and robotic devices - Safety requirements for industrial robots - Part 1: Robots

- Refer to product catalogue, Operation Manual and Handling Precautions for SMC Products for additional information.
- Keep this manual in a safe place for future reference.

|                |  |
|----------------|--|
| <b>Danger</b>  | Danger indicates a hazard with a high level of risk which, if not avoided, will result in death or serious injury.     |
| <b>Warning</b> | Warning indicates a hazard with a medium level of risk which, if not avoided, could result in death or serious injury. |
| <b>Caution</b> | Caution indicates a hazard with a low level of risk which, if not avoided, could result in minor or moderate injury.   |

**Warning**

- Always ensure compliance with relevant safety laws and standards.
- All work must be carried out in a safe manner by a qualified person in compliance with applicable national regulations.

**Caution**

- The product is provided for use in manufacturing industries only. This product must not be used in residential areas.

2 Specifications

**Warning**

- Special products (-XA###) might have specifications different from those shown in this Instruction Manual. Contact SMC for specific drawings.

2 Specifications - continued

2.1 Functional description

The product consists of either one or two solenoid operated 2 position 3 port valves, which are connected to a main air supply (in some cases via an integrated soft-start valve). The valves are capable of performing the safety function described in this document. The soft start valve is intended to allow the end user to perform machine operational start up procedures with reduced flow potential until a pre-set operational pressure is achieved. At the defined pressure the soft start valve allows full flow in order to achieve full operation. The soft start function is intended for machine operation purposes and not for the performance of a safety function.

2.2 Valve specifications

| Size   | Standard                               |             | High pressure |        |
|--|--|-------------|---------------|--------|
|  | VP546                                  | VP746       | VP546K        | VP746K |
| Type of Actuation  | Normally closed                        |             |               |        |
| Return method  | Spring return                          |             |               |        |
| Fluid  | Air                                    |             |               |        |
| Proof pressure [MPa]                                       | 1.05                                   |             | 1.5           |        |
| Internal pilot operating pressure range [MPa]              | 0.25 to 0.7                            |             | 0.25 to 1     |        |
| External pilot operating pressure range [MPa]              | Main pressure                          | S, D type   | 0.05 to 0.7   |        |
|  | SS, DS type                            | SS, DS type | 0.25 to 0.7   |        |
| Pilot pressure   | Same as main pressure (min. 0.25)      |             |               |        |
| Ambient and operating fluid temperature [°C]               | -10~50 (no freezing / no condensation) |             |               |        |
| Ambient humidity   | 20 to 90% RH (no condensation)         |             |               |        |
| Lubrication  | Not required (Note 1)                  |             |               |        |
| Operating frequency: Max                                   | 30 cycles per minute                   |             |               |        |
| Operating frequency: Min                                   | 1 cycle per week (Note 2)              |             |               |        |
| Duty cycle   | Contact SMC                            |             |               |        |
| Response time  | See 2.11.2                             |             |               |        |
| Impact / Vibration resistance (Note 3) [m/s <sup>2</sup> ] | 150 / 30 (Note 4, 5)                   |             |               |        |
| Air quality  | 5 µm filtration or smaller             |             |               |        |
| Environment  | Indoor use only                        |             |               |        |
| Enclosure (based on IEC60529)                              | IP65                                   |             |               |        |

| B <sub>10D</sub> [cycles]      | 10,000,000 (Note 6)  |          | 5,000,000 (Note 6)   |           |
|--------------------------------|--|----------|--|-----------|
|                                | M-S type   | M-D type | M-SS type  | M-DS type |
| Mission time [years or cycles] | Maximum 20 years or when the number of cycles = B <sub>10D</sub> , whichever occurs first (Note 7) |          | Maximum 20 years or when the number of cycles = B <sub>10D</sub> , whichever occurs first (Note 7) |           |
| Mass (examples) [kg]           | 0.5  | 0.8      | 0.7  | 1.3       |
|                                | 0.8  | 1.4      | 1.3  | 1.9       |

Table 1.

- Note 1) If lubrication is used in the system, use class 1 turbine oil (no additive), ISO VG32.
- Note 2) The valve must be energised/de-energised at least once per week.
- Note 3) See section 2.5 for switch impact/vibration specifications.
- Note 4) Impact resistance:
  - No malfunction resulted from the impact test using a drop impact tester.
  - The test was performed in both energised and de-energised states to the axis of and at right angles to the direction of the main valve and armature (Values quoted are for a new valve).
- Note 5) Vibration resistance:
  - No malfunction occurred in a one-sweep test between 5 and 2000 Hz.
  - Test was performed in both energised and de-energised states to the axis of and at right angles to the direction of the main valve and armature (Values quoted are for a new valve).
- Note 6) The B<sub>10D</sub> figure is estimated from SMC life tests under SMC test conditions.
- Note 7) See section 2.11.4 for details.

2.3 Flow characteristics (Note 1, 2)

| VP546            | S type    |           | D type    |           | SS type   |           | DS type   |           |
|------------------|-----------|-----------|-----------|-----------|-----------|-----------|-----------|-----------|
|                  | 1→2 (P→A) | 2→3 (A→R) | 1→2 (P→A) | 2→3 (A→R) | 1→2 (P→A) | 2→3 (A→R) | 1→2 (P→A) | 2→3 (A→R) |
| C[liter/(s.bar)] | 8.8       | 8.3       | 6.6       | 8.3       | 6.6       | 8.3       | 5.6       | 8.3       |
| b                | 0.18      | 0.18      | 0.13      | 0.18      | 0.13      | 0.18      | 0.06      | 0.18      |
| Cv               | 2.1       | 2.0       | 1.5       | 2.0       | 1.5       | 2.0       | 1.3       | 2.0       |

Table 2.

2 Specifications - continued

| VP746                | S type    |           | D type    |           | SS type   |           | DS type   |           |
|----------------------|-----------|-----------|-----------|-----------|-----------|-----------|-----------|-----------|
|                      | 1→2 (P→A) | 2→3 (A→R) | 1→2 (P→A) | 2→3 (A→R) | 1→2 (P→A) | 2→3 (A→R) | 1→2 (P→A) | 2→3 (A→R) |
| Flow characteristics | 14.2      | 12.3      | 10.8      | 12.3      | 10.6      | 12.3      | 8.9       | 12.3      |
| C[liter/(s.bar)]     | 14.2      | 12.3      | 10.8      | 12.3      | 10.6      | 12.3      | 8.9       | 12.3      |
| b                    | 0.22      | 0.25      | 0.13      | 0.25      | 0.11      | 0.25      | 0.08      | 0.25      |
| Cv                   | 3.4       | 3.0       | 2.5       | 3.0       | 2.4       | 3.0       | 2.0       | 3.0       |

Table 3.

Note 1) Flow characteristics shown are for standard pressure type and high pressure type.

Note 2) For flow during soft start mode, see section 2.8.2.

The flow direction is identifiable by an arrow in the manifold itself. Please see some examples in Figure 1.

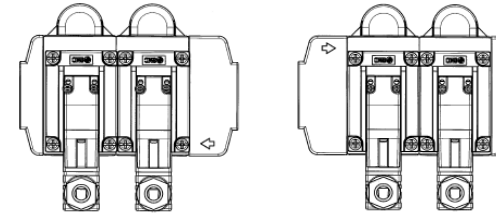

Figure 1.

2.4 Pilot valve specifications

| Electrical entry              | D or Y type DIN terminal (See 3.8.1) |
|-------------------------------|--------------------------------------|
| Coil rated voltage [VDC]      | 24                                   |
| Allowable voltage fluctuation | -10% to +10% (Note 1)                |
| Power consumption [W]         | 0.45 per solenoid                    |
| Surge voltage suppressor      | Varistor                             |
| Indicator light               | LED                                  |

Table 4.

Note 1) Valve state is not defined if electrical input is outside of specified operating ranges.

2.5 Limit switch specifications

|                                       | Omron                      | Rockwell Automation        |
|---------------------------------------|----------------------------|----------------------------|
| Electrical entry                      | G1/2 conduit M12 connector | M12 connector              |
| Contact resistance [mΩ]               | 25 max                     | 50 max                     |
| Minimum permissible load              | 5 VDC 1mA (resistive load) | 5 VDC 5mA (resistive load) |
| Rated voltage [VDC]                   | 24                         |                            |
| Maximum permitted load current [mA]   | 50 (Note 1)                |                            |
| Maximum permitted load inductance [H] | 0.5 (Note 1)               |                            |
| Rated insulation voltage [V]          | 300                        | 600                        |
| Electric shock protection class       | Class II (EN 60947-5-1)    |                            |
| Pollution degree                      | Level 3 (EN 60947-5-1)     |                            |
| Vibration / Impact resistance         | See note 2, 3)             |                            |

Table 5.

- Note 1) For the purposes of EN ISO 13849-2 table D.2 the switch is de-rated from the figures specified by the switch manufacturer. The switch load must be limited in the application in order to maintain the specified safety performance, including the B<sub>10D</sub> and mission time.
- Note 2) The Omron switch is subject to the following vibration and impact limitations specified by the manufacturer:
  - 'Contact opening time should be less than a 1 ms pulse under vibration of 0.75 mm single amplitude, 10 to 55 Hz, 10 cycles in each direction for 45 minutes.'
  - Impact: 300 m/s<sup>2</sup> (Contact open time: 1 ms maximum pulse).
- Note 3) The Rockwell Automation switch is subject to the following vibration and impact limitations specified by the manufacturer:
  - Impact: IEC60068-2-7 (30gn (300m/s<sup>2</sup>)), 3 pulses per axis.
  - Vibration: IEC60068-2-6 (10...55Hz, 0.35mm amplitude).

2.6 Safety specification

- Safety function: When the valve is de-energised, the protected circuit is vented to atmosphere.
- The valve assembly is compatible for use in systems up to either Category 2 or Category 4 depending on configuration according to the Safety Standard when integrated into a suitable safety system.
- In this section, 'the Safety Standard' refers to EN ISO 13849-1 and 'the Validation Safety Standard' refers to EN ISO 13849-2 as referenced in the Declaration of Conformity.
- Information about compatibility with the Safety Standard is given in section 2.11.

2 Specifications - continued

2.7 Pneumatic symbols (examples)

2.7.1 S type

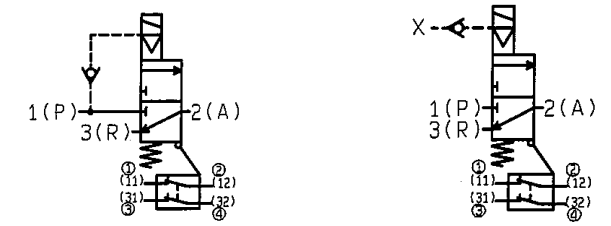

Figure 2. Internal pilot (Omron switch variant shown for reference)

Figure 3. External pilot (Omron switch variant shown for reference)

2.7.2 D type

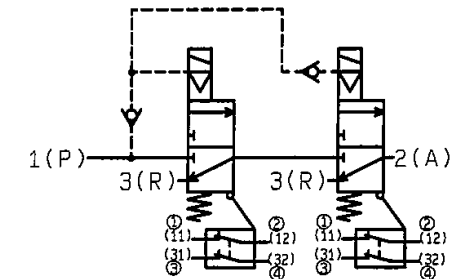

Figure 4. Internal pilot (Omron switch variant shown for reference)

2.7.3 SS type

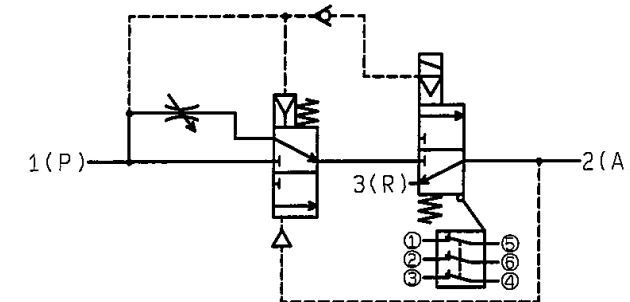

Figure 5. External pilot (Omron switch variant shown for reference)

Figure 6. Internal pilot (Rockwell switch variant shown for reference)

2 Specifications - continued

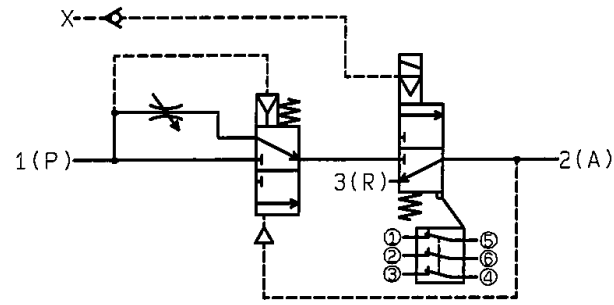

Figure 7. External pilot (Rockwell switch variant shown for reference)

2.7.4 DS type

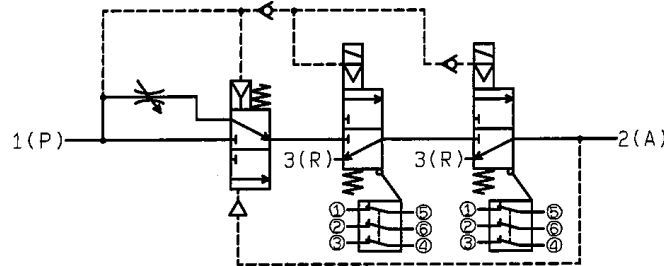

Figure 8. Internal pilot (Rockwell switch variant shown for reference)

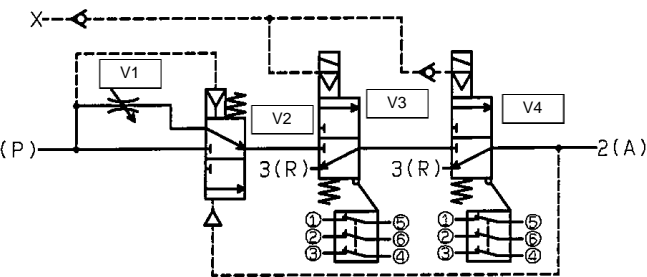

Figure 9. External pilot (Rockwell switch variant shown for reference)

2.8 Soft start specification and operating principle

2.8.1 Operating principle

- In a safety related application, the machine safety system will energise the safety valves (V3 and V4 in Figure 9) when the machine is safe to operate. When both valves are energised air will flow into the protected system via port 2 (A). The flow is initially limited by needle valve V1 and pressure in the protected system will remain low as the system fills or actuators move slowly. The pressure will eventually rise as the system becomes full or the actuators stop moving. As P2 pressure increases (see Figure 10) valve V2 switches and valve V1 is by-passed. In this condition air will flow into the protected system according to the figures given in section 2.3.
- When either of the valves V3 or V4 are de-energised the protected system is vented to atmosphere. When the protected system pressure drops below P2 (see Figure 10) valve V2 returns to its spring returned state with V1 limiting the flow to V3 and V4.

2 Specifications - continued

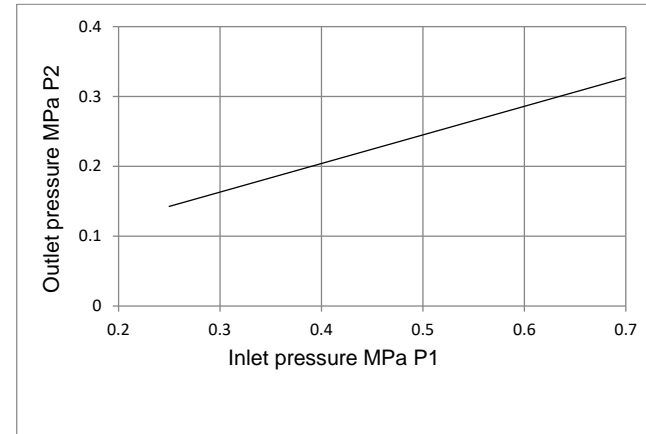

Figure 10. Switching pressure (Close → Open) of soft start-up valve V2

2.8.2 Soft start flow

The adjustable flow restriction is set by V1, see Figure 11 and 12.

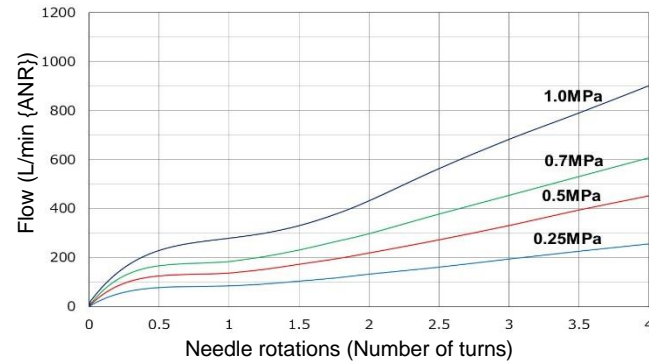

Figure 11. Needle valve flow characteristics VP546(K)-SS/DS (Use this graph as a guide only)

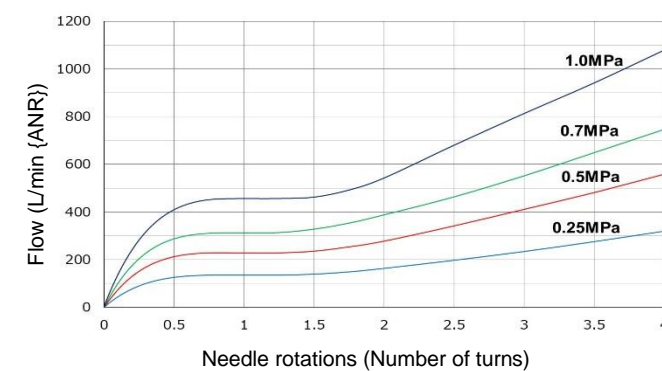

Figure 12. Needle valve flow characteristics VP746(K)-SS/DS (Use this graph as a guide only)

2 Specifications - continued

2.9 Declaration of conformity

Original declaration Doc. No. VP500-TF122-134EU

**EU DECLARATION OF CONFORMITY**

С Декларация за съответствие EU Proklamace o shodě EU-överensstämmeiserklaring EU-Konformitätserklärung Δήλωση συμμόρφωσης ΕΕ Declaración UE de conformidad EU vastavusdeklaratsioon

EU-vaatimustenmukaisuusvakuutus Declaration UE de conformité EU-egyetemesítő nyilatkozat Dichiarazione UE di conformità ES actividades de declaración EU atbilstības deklarācija

EU-coformiteitsverklaring Deklaracja zgodności UE Declarație UE de conformitate Declaratia de conformitate ue Vyhlášení o shodě EU Izjava EU o skladnosti EU-förklarar om överensstämme

SMC Corporation, 4-14-1, Sotokanda, Chiyoda-ku, Tokyo 101-0021, JAPAN, declares under its sole responsibility, that the following equipment:

**Modular residual pressure relief valve with direct monitoring for use in safety related systems**  
VP546(-XA###)  
VP746(-XA###)

Batch No. AU onwards Marked H

is in conformity with the relevant Union harmonisation legislation and has been demonstrated to fulfil the requirements with reference to the harmonised standard(s) or applied standard(s) as listed below:

| Directive                                     | Requirements | Harmonised/applied standards                                   |
|---|--------------|--|
| 2006/42/EC<br>(Machinery Directive)           | Annex I      | EN ISO 13849-1:2015<br>EN ISO 13849-2:2012<br>EN ISO 4414:2010 |
| 2014/30/EU<br>[EMC Directive]                 | Annex I      | EN 61000-6-2:2005  |
| 2011/65/EU <sup>(1)</sup><br>[RoHS Directive] | Annex II     | EN IEC 63000:2018  |

<sup>(1)</sup> Including substances added by Commission Delegated Directive (EU) 2015/863.

Name and address of the person authorised to compile the technical file<sup>(2)</sup>:

Mr Lucio Moriggi, General Manager, SMC Italia S.p.A.  
Via delle Donne Lavoratrici, 21-20861 BRUGHERIO (MB), ITALY

Importer/Distributor contact details www.SMC.eu, www.SMCworld.com

Shinichi Yoshimura  
General Manager  
Product Development Division - 1

Tokyo, Date: 6<sup>th</sup> July, 2022

2 Specifications - continued

Original declaration Doc. No. VP500-TF122-134UK

**UK DECLARATION OF CONFORMITY**

SMC Corporation, 4-14-1, Sotokanda, Chiyoda-ku, Tokyo 101-0021, JAPAN, declares under its sole responsibility, that the following equipment:

**Modular residual pressure relief valve with direct monitoring for use in safety related systems**  
VP546(-XA###)  
VP746(-XA###)

Batch No. AU onwards Marked H

is in conformity with relevant statutory regulations (including amendments) and has been demonstrated to fulfil the requirements with reference to the designated standards as listed below:

| Statutory Instrument   | Requirements | Designated Standards/ Technical Specifications                 |
|--|--------------|--|
| Supply of Machinery (Safety) Regulations 2008  | Schedule 2   | EN ISO 13849-1:2015<br>EN ISO 13849-2:2012<br>EN ISO 4414:2010 |
| Electromagnetic Compatibility Regulations 2016   | Schedule 1   | EN 61000-6-2:2005  |
| The Restriction of the Use of Certain Hazardous Substances in Electrical and Electronic Equipment Regulations 2012 | Schedule 2   | EN IEC 63000:2018  |

Importer/Distributor contact details:

SMC  
Vincent Avenue  
Milton Keynes  
MK8 0AN

www.smc.eu, www.smcworld.com

The person authorised to compile the technical file is the person named at the address below:

Tokyo, Date: 6<sup>th</sup> July, 2022

Shinichi Yoshimura  
General Manager  
Product Development Division - 1  
4-2-2, Kinunodai, Tsukubamirai-shi,  
Ibaraki 300-2436, JAPAN

2.10 Batch code

The batch code indicated in the product label translates to construction year / month according to the following table (e.g. "CQ = Mar 2024):

| Construction Year / Month | Production batch codes |     |     |     |     |     |     |     |     |     |     |     |
|---------------------------|------------------------|-----|-----|-----|-----|-----|-----|-----|-----|-----|-----|-----|
|                           | Jan                    | Feb | Mar | Apr | May | Jun | Jul | Aug | Sep | Oct | Nov | Dec |
| 2024                      | Co                     | CP  | CQ  | CR  | CS  | CT  | CU  | CV  | CW  | CX  | Cy  | CZ  |
| 2025                      | Do                     | DP  | DQ  | DR  | DS  | DT  | DU  | DV  | DW  | DX  | Dy  | DZ  |
| ...                       | ...                    | ... | ... | ... | ... | ... | ... | ... | ... | ... | ... | ... |
| 2027                      | Fo                     | FP  | FQ  | FR  | FS  | FT  | FU  | FV  | FW  | FX  | Fy  | FZ  |

Table 6.

2.11 Safety system

2.11.1 Timing diagram

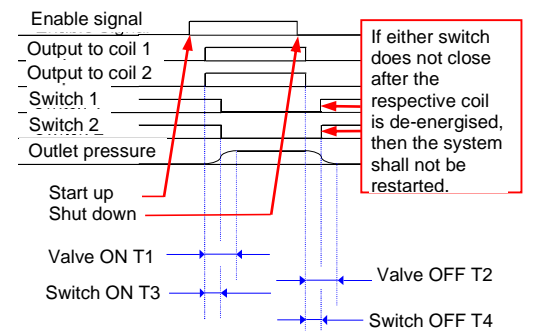

Figure 13. Diagram for a duplex valve

Note: The monitor switches are Normally Closed, i.e. closed when the valve solenoids are de-energised. The monitor signals are therefore shown 'High' when the valve is de-energised.

2.11.2 VP546(K) / VP746(K) valve and switch response

- The valve response time ON (T1) depends on the supply pressure, the volume of the protected system and the soft start operation (see 2.8). T1 times are not related to the safety function.

## 2 Specifications - continued

- The valve response time OFF (T2) depends on the volume (V) and the flow capacity of the protected system. It is defined as the time interval in which the pressure in a test volume connected to an outlet port of the valve reduces from 0.63 MPa to 0.05 MPa in response to a change in the control signal to that valve. Refer to the tables below for indicative values under SMC conditions.
- The ON response time of the limit switch (T3) is shown in the table below.
- The OFF response time of the limit switch (T4) is shown in the table below.

### Caution

- Response time values are for reference only and it is the system integrator's responsibility to obtain the actual values.

| Volume / litre | Valve OFF response / T2, ms | Switch response |                         |
|----------------|-----------------------------|-----------------|-------------------------|
|                |                             | T3, ms          | T4, ms                  |
| 3              | 1110                        | 30              | 155<br>(250 for K type) |
| 10             | 3560                        |                 |                         |
| 20             | 7060                        |                 |                         |

Table 7. VP546(K) response time

| Volume / litre | Valve OFF response / T2, ms | Switch response |                         |
|----------------|-----------------------------|-----------------|-------------------------|
|                |                             | T3, ms          | T4, ms                  |
| 3              | 930                         | 40              | 280<br>(350 for K type) |
| 10             | 2750                        |                 |                         |
| 20             | 5350                        |                 |                         |

Table 8. VP746(K) response time

### Caution

- Response times are based on tests under SMC conditions and are not guaranteed. Always observe the terms of 2.11.3.
- Exhaust times will increase on the duplex valves when only one channel is functioning in a fault condition.

### 2.11.3 Relationship of flow and response performance to safety function

- The safety function is to vent the compressed air in the protected system so that the protected system does not present a hazard when the application operates under the control of a suitable safety system.
- The time taken for the air to vent and remove the hazard is a function

of:

- The flow capacity of the valve
- The flow restriction of silencers fitted to the valve
- The volume of the protected system
- The pressure of the air in the protected system
- The flow restrictions in the protected system
- The end user is expected to establish the time taken to vent the application system and ensure that this time is consistent with the requirement of the overall safety system. This includes the selection of suitable silencers.
- The performance of the system should be validated by test after each installation to ensure that the actual performance of the valve is consistent with the safety function. Validate the performance of the system under all foreseeable operating conditions of pressure, flow and volume.

### 2.11.4 Mission time according to the Safety Standard

The operational life of the product shall be limited to the mission time stated in section 2.2. The user is expected to calculate an equivalent figure in time units from the B<sub>10D</sub> value based on the operating cycles of the application. In no circumstances can the mission time exceed 20 years. After the mission time has expired for the component it shall be replaced with a new unit.

### 2.11.5 MTTFD according to the Safety Standard

The B<sub>10D</sub> for the component given in section 2.2 is derived from product knowledge and based on specific life tests. The system integrator should use this data to determine MTTFD and the Performance Level (PL) of the system using the methods described in the Safety Standard.

### 2.11.6 Diagnostic Coverage according to the Safety Standard

These valves are fitted with 'direct monitoring' according to Table E1 of EN ISO 13849-1. When properly integrated these valve assemblies can contribute to a DC value of 99% to the DCavg for the complete safety function.

### 2.11.7 Common Cause Failures according to the Safety Standard

CCF analysis is the responsibility of the system integrator. The single valve is a single channel system so CCF does not apply.

## 2 Specifications - continued

The duplex valve has 2 channels made of identical valves. The use of this valve might not allow the system calculation to include CCF points for diversity.

## 3 Installation

### 3.1 Installation

#### Warning

- Do not install the product unless the safety instructions have been read and understood.
- Do not install the product if it appears to have been damaged during transport.
- The valve must be protected from contamination from the downstream system when air is vented through the valve.
- Do not paint the product.
- Do not remove or cover up warnings or specifications printed or affixed to the product.
- Ensure sufficient space for maintenance activities. When installing the products, allow access for maintenance.
- Ensure that the connections of pipework and cables to the unit do not result in a residual trip hazard to system operators or maintainers.
- If air leakage increases or equipment does not operate to specification, stop operation.
- Check mounting conditions when air and power supplies are connected. Initial function and leakage tests should be performed after installation.

### 3.2 Environment

#### Warning

- Do not use in an environment where corrosive gases, chemicals, salt water or steam are present.
- Do not use in an explosive atmosphere.
- Do not expose to direct sunlight. Use a suitable protective cover.
- Do not install in a location subject to vibration or impact in excess of the product's specifications.
- Do not mount in a location exposed to radiant heat that would result in temperatures in excess of the product's specifications.
- Do not install in a location subject to strong magnetic fields.
- Do not install in an EMC environment other than 'industrial' according to the scope of standard listed on the Declaration of Conformity.

- If it is used in an environment where there is possible contact with oil, weld spatter, etc., exercise preventive measures.
- Products compliant with IP65 or more enclosures are protected against dust and water, however, these products cannot be used in water.
- Products compliant with IP65 or more enclosures satisfy the specifications by mounting each product properly. Be sure to read the Specific Product Precautions for each product.
- When the solenoid valve is mounted in a control panel or is energised for a long time, make sure ambient temperature is within the specification of the valve.
- Ambient humidity  
When using the valve in environments with low humidity, take measures to prevent static. If the humidity rises, take measures to prevent the adhesion of water droplets on the valve.  
Do not use in high humidity environment where condensation occurs.
- Altitude limitation is 1000 m above sea level for valves with Omron switches and 2000 m for valves with Rockwell switches.

### 3.3 Piping

#### Caution

- Before connecting piping make sure to clean up chips, cutting oil, dust etc.
- When installing piping or fittings, ensure sealant material does not enter inside the port. When using seal tape, leave 1 thread exposed on the end of the pipe/fitting.

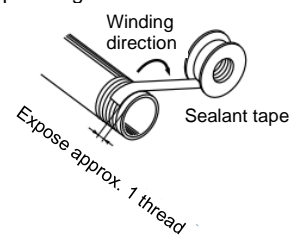

Figure 14.

- Tighten fittings to the specified tightening torque.

## 3 Installation - continued

| Port   | Connection thread size (R, NPT) | Tightening torque [N·m] |
|--|---------------------------------|-------------------------|
| X (External pilot)   | 1/8 (Rc, G, NPT)                | 3 to 5                  |
| 3(R) for VP546 / VP746 (Compact resin type/male thread silencer AN30-03) | 3/8 (G)                         | See Note 1              |

Table 9.

Note 1) Hold the tip of the main body (the side without thread) and screw it in. At the point where the thread begins to feel tight, use a wrench on the hexagonal flats to tighten an additional 1/4 turn. Refer to catalogue AN series Specific Product Precautions (silencers).

### 3.4 Lubrication

#### Caution

- SMC products have been lubricated for life at manufacture, and do not require lubrication in service.
- If a lubricant is used in the system, use turbine oil Class 1 (no additive), ISO VG32. Once lubricant is used in the system, lubrication must be continued because the original lubricant applied during manufacturing will be washed away.

### 3.5 Air supply

#### Warning

- Please consult with SMC when using the product in applications other than compressed air.
- Compressed air containing a large amount of water vapour can cause malfunction of pneumatic equipment such as valves. An air dryer or water separator should be installed upstream from filters.
- If condensation in the drain bowl is not emptied on a regular basis, the bowl will overflow and allow the condensation to enter the compressed air lines causing malfunction of pneumatic equipment.
- If the drain bowl is difficult to check and remove, installation of a drain bowl with an auto drain option is recommended.
- Use clean air. If the compressed air supply includes chemicals, synthetic materials (including organic solvents), salinity, corrosive gas etc., it can lead to damage or malfunction.

#### Caution

- When selecting a regulator or a filter regulator, use piping larger than

the recommended size with sufficient flow rate characteristics.

- For extended piping between the regulator and the valve (inlet piping), keep piping as short as possible (1 m or less).
- When extremely dry air is used as the fluid, degradation of the lubrication properties inside the equipment may occur, resulting in reduced reliability (or reduced service life) of the equipment. Please consult with SMC.
- Install an air filter upstream near the valve. Select an air filter with a filtration size of 5 µm or smaller.
- Take measures to ensure air quality, such as by installing an aftercooler, air dryer, or water separator.
- If excessive carbon powder is seen, install a mist separator on the upstream side of the valve. If excessive carbon dust is generated by the compressor it may adhere to the inside of a valve and cause it to malfunction.
- When using the external pilot type valve, it is recommended that the main supply pressure and the pilot pressure are taken from separate lines. The A/B options are available which have a check valve fitting in the pilot port (see "How to order" in catalogue or drawing).
- If necessary, a check valve can be installed in the external pilot line to prevent a drop in pilot pressure.

#### Warning

- Ensure there is no hazard created by any air trapped between the check valve and the pilot valves.
- Minimise the distance between the valve and the air supply and between the valve and the protected system.
- Do not place any devices between the valve and the protected system that might interfere with the safety function.
- The exhaust ports of the valves should never be blocked and must be protected from ingress of contamination by a suitable silencer or device which does not affect the valve function.

### 3.6 Mounting

#### Caution

- The valves are compatible with the modular FRL unit AC-D series, please observe the AC-D precautions for mounting orientation.
- The valves require the use of Y#00T-D spacers with brackets.

## 3 Installation - continued

| Size       | Spacer with bracket | Tightening torque [N·m] |
|------------|---------------------|-------------------------|
| VP546 AC30 | Y300T-D             | 1.2±0.05                |
| VP746 AC40 | Y400T-D             | 1.2±0.05                |

Table 10.



Figure 15. Y#00T-D

- If a threaded inlet/outlet port is required, a piping adapter E300-###-D (for VP546) and E400-###-D (for VP746) is required. Refer to catalogue "Modular F.R.L. Units AC-D" for details.

Port size

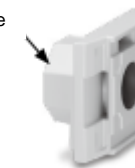

Figure 16. E#00-###-D

### 3.7 Noise

#### Caution

- It is recommended that silencers or noise reduction devices are fitted to protect personnel from transient noise when the valves are de-energised.
- The pressure drop of silencers or devices must be taken into account during the design and testing of the application system to ensure that the safety function is maintained.

### 3.8 Electrical connection

#### Caution

- When electric power is connected to a solenoid valve, be careful to apply the proper voltage. Improper voltage may cause malfunction or coil damage.
- Check if the connections are correct after completing all wiring.

#### 3.8.1 Pilot valve

##### 3.8.1.1 Surge voltage suppression

For DIN terminal:

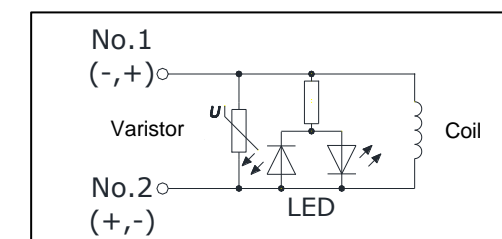

DIN terminal has no polarity.

Figure 17.

##### 3.8.1.2 Pilot valve connections

- DIN interchangeability  
The 'Y' type DIN terminal corresponds to the DIN connector with a terminal pitch of 8 mm, which complies with EN175301-803C. The pitch is different from the 'D' type DIN connector (which has a pitch of 9.4 mm), the two types are therefore not interchangeable.
- Applicable cable dia: Ø3.5 ~ Ø7 mm

##### 3.8.1.3 Leakage voltage

Ensure that any leakage voltage caused by the leakage current when the switching element is OFF causes ≤ 3% of the rated voltage across the valve.

### 3 Installation - continued

#### 3.8.1.4 Using DIN connector with the pilot valve

##### Caution

##### Connection

- Loosen the holding screw and pull the connector out of the solenoid valve terminal block.
- After removing the holding screw, insert a flat head screwdriver, etc. into the notch on the bottom of the terminal block and pry it open, separating the terminal block and the housing.
- Loosen the terminal screws (slotted screws) on the terminal block, insert the cores of the lead wires into the terminals according to the connection method, and fasten them securely with the terminal screws.
- Secure the cord by fastening the gland nut.

##### Caution

- When making connections, take note that using other than the supported size (ø3.5 to ø7) heavy duty cord will not satisfy IP65 (enclosure) standards.
- Also, be sure to tighten the gland nut and holding screw within their specified torque ranges.
- Ensure sealing gaskets are correctly installed.

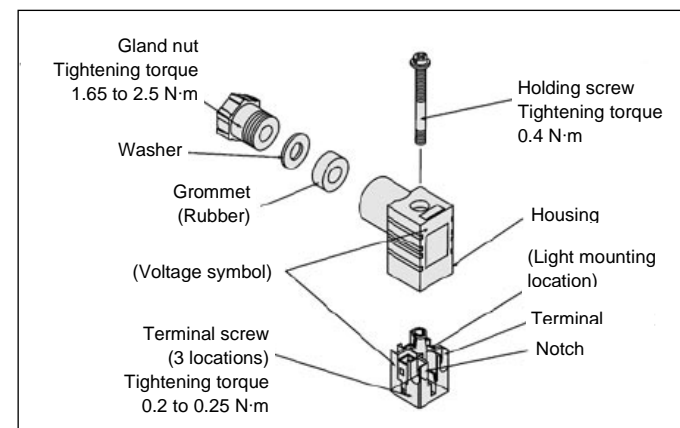

Figure 18.

##### Warning

The ground terminal is connected to the coil assembly only and does not provide a protective earth for the body of the valve.

##### Changing the entry direction

After separating the terminal block and housing, the cord entry can be changed by attaching the housing in the desired direction (4 directions at 90° intervals).

\* When equipped with a light, be careful not to damage the light with the cord's lead wires.

##### Precautions

Plug in and pull out the connector vertically without tilting to one side.

##### Compatible cable

Cord O.D.: ø3.5 to ø7  
(Reference) 0.5 mm<sup>2</sup>, 2-core or 3-core, equivalent to JIS C 3306

#### 3.8.2 Omron limit switch: conduit type

##### 3.8.2.1 Limit switch screw tightening torque

| Screw position              | Tightening torque [N·m] |
|-----------------------------|-------------------------|
| Terminal screw              | 0.6 to 0.8              |
| Cover clamping screw        | 0.5 to 0.7              |
| Conduit mounting connection | 1.8 to 2.2              |

Table 11.

##### 3.8.2.2 Wiring

- When connecting to the terminals via insulating tube and M3.5 crimp terminals, arrange the crimp terminals as shown below so that they do not rise up onto the case or the cover. Application lead wire size: AWG20 to AWG18 (0.5 to 0.75 mm<sup>2</sup>)

### 3 Installation - continued

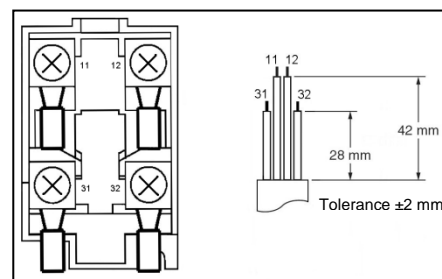

Figure 19.

- Do not push crimp terminals into gaps in the case interior. Doing so may cause damage or deformation of the case.
- Use crimp terminals not more than 0.5 mm in thickness. Otherwise, they will interfere with other components inside the case. The crimp terminal shown below are not more than 0.5 mm thick.

| Manufacturer | Type   | Wire size                    |
|--------------|--|------------------------------|
| J.S.T.       | FV0.5-3.7 (F type)<br>V0.5-3.7 (straight type) | AWG20 (0.5 mm <sup>2</sup> ) |

J.S.T. is a Japanese manufacturer.

Table 12.

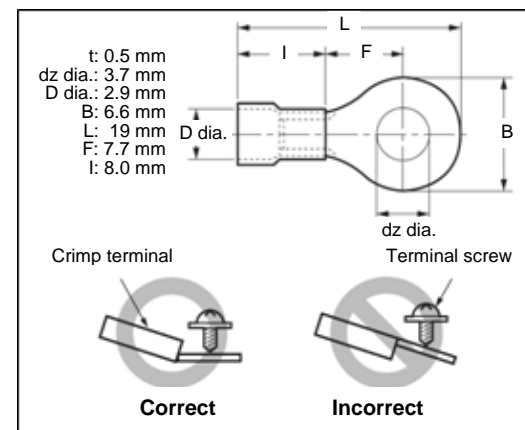

Figure 20.

##### 3.8.2.3 Conduit opening

- Connect a recommended connector to the opening of the conduit and tighten the connector to the specified torque. The case may be damaged if an excessive tightening torque is applied.
- Use a cable with a suitable diameter for the connector.

##### 3.8.2.4 Recommended connectors

- Use connectors with screws not exceeding 9 mm, otherwise the screws will protrude into the case interior, interfering with other components in the case. The connectors listed in the following table have connectors with thread sections not exceeding 9 mm. Use the recommended connectors to ensure conformance to the stated IP level.

| Size  | Manufacturer | Model             | Applicable cable diameter |
|-------|--------------|-------------------|---------------------------|
| G 1/2 | LAPP         | ST-PF1/25380-1002 | 6.0 to 12.0 mm            |
|       | Ohm Denki    | OA-W1609          | 7.0 to 9.0 mm             |
|       |              | OA-W1611          | 9.0 to 11.0 mm            |

LAPP is a German manufacturer.

Ohm Denki is a Japanese manufacturer.

Table 13. Recommended conduit connectors

### 3 Installation - continued

- Use LAPP connectors together with seal packing (JPK-16, GP-13.5, GPM20, or GPM12), and tighten to the specified tightening torque. Seal packing is sold separately.

#### 3.8.3 Omron limit switch: M12 connector type

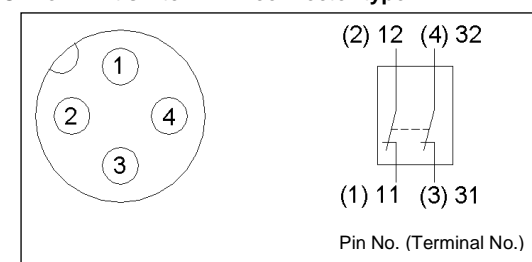

Figure 21.

Orientation of the M12 connector is not guaranteed. Only a straight connector should be used.

#### 3.8.4 Rockwell Automation limit switch: M12 connector type

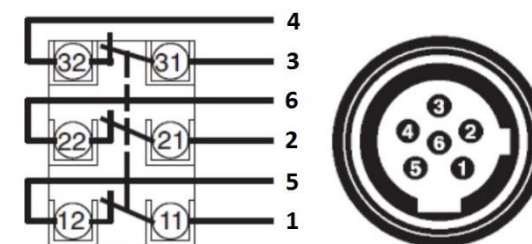

Figure 22.

##### 3.8.4.1 Socket tightening

- Turn the socket connector screws by hand and tighten until no space remains between the socket and the plug.
- Make sure that the socket connector is tightened securely. Otherwise, the rated degree of protection may not be maintained and vibration may loosen the socket connector.

- Orientation of the M12 connector is not guaranteed. Only a straight connector should be used.

#### 3.9 Residual voltage

##### Caution

- If a Zener diode or varistor voltage suppressor is used, the suppressor arrests the back EMF voltage from the coil to a level in proportion to the rated voltage.
- Ensure the transient voltage is within the specification of the host controller.
- Contact SMC for the Zener diode or varistor residual voltage.

#### 3.10 Countermeasure for surge voltage

##### Caution

- At times of sudden interruption of the power supply, the energy stored in a large inductive device may cause non-polar type valves in a de-energised state to switch.
- When installing a breaker circuit to isolate the power, consider a valve with polarity (with polarity protection diode), or install a surge absorption diode across the output of the breaker.

#### 3.11 Extended periods of continuous energization

##### Warning

- If a valve is continuously energized for an extended period of time, the temperature of the valve will increase due to the heat generated by the coil assembly.

### 4 How to Order

Refer to drawings or catalogue for 'How to Order'.

### 5 Outline Dimensions

Refer to drawings or catalogue for outline dimensions.

### 6 Maintenance

#### 6.1 General maintenance

##### Caution

- Not following proper maintenance procedures could cause the product to malfunction and lead to equipment damage.
- If handled improperly, compressed air can be dangerous.
- Maintenance of pneumatic systems should be performed only by qualified personnel.
- Before performing maintenance, turn off the power supply and be sure to cut off the supply pressure. Confirm that the air is released to atmosphere.
- After installation and maintenance, apply operating pressure and power to the equipment and perform appropriate functional and leakage tests to make sure the equipment is installed correctly.
- If any electrical connections are disturbed during maintenance, ensure they are reconnected correctly and safety checks are carried out as required to ensure continued compliance with applicable national regulations.
- Do not make any modification to the product.
- Do not disassemble the product, unless required by installation or maintenance instructions.

##### Warning

- To avoid any hazard created by air trapped between the check valve and pilot valve, energise and de-energise the solenoid valve several times with no air supply to port 1 or to the external pilot port.

#### 6.2 Replacement parts

##### Warning

- Under no circumstances attempt to change the solenoid of the pilot valve as this is an integral part of the valve and doing so will invalidate SMC warranty.
- Do not attempt to replace the limit switches. M4 limit switch retaining screws are secured into position with adhesive, do not remove.
- There are no replaceable parts on these safety products.

#### 6.3 Periodic testing

- The product should be tested for proper operation of the safety function once per month or whenever considered necessary for the purposes of the end user. The test should consist of operation of the safety

system and observation of the following:

When the connected control system is energising the solenoids:

- Check that the solenoid indicator lights are illuminated.
- Check that the connected downstream system is properly pressurised.
- Check that the switch contacts are open.
- For duplex valve assemblies check that when only one channel of the system (one of the solenoids) is energised the protected system does not become pressurised. Check this for both channels.

When the connected control system is not energising the solenoids:

- Check that the solenoid indicator lights are not illuminated.
- Check that the connected downstream system is properly vented to atmosphere and ensure that the condition of the silencers is not causing an extension of the vent time.
- Check that the switch contacts are closed.
- For the duplex valve assemblies check that when only one channel of the system (one of the solenoids) is de-energised the protected system is vented to atmosphere. Check this for both channels.

##### Warning

The specification of the valve requires the valve to be cycled (energised and de-energised) at least once per week.

#### 6.4 Silencers

##### Warning

- Ensure that any silencers fitted to the valve remain clean and uncontaminated in operation because blockage will affect the safety function.
- These silencers are to be fitted by the end user during installation.
- Examine any silencers at least once per month and more frequently if necessary due to the nature of the application environment.

## 6 Maintenance - continued

### 6.5 Troubleshooting guide

| Symptom                                      | Possible fault                           | Action   |
|--|--|--|
| Valve does not open                          | Pilot valve is not energised             | Check pilot solenoid indicator (light) is illuminated and that voltage is within specification |
|  | Supply pressure is too low               | Check supply pressure  |
|  | Pilot valve has failed                   | Replace the entire unit  |
| Valve does not close                         | Pilot valve remains energised            | Check pilot solenoid indicator (light)   |
|  | Pilot valve is jammed                    | Replace the entire unit  |
|  | Main valve is jammed                     | Replace the entire unit  |
|  | Supply pressure is too high              | Check supply pressure  |
| Switch contacts do not open                  | Switch has failed                        | Replace the entire unit  |
| Switch contacts do not close                 | Switch has failed                        | Replace the entire unit  |
| Valve operation is noisy or erratic          | Supply flow is inadequate                | Increase supply pressure and/or flow   |
| Valve is slow to pressurise protected system | Supply flow is inadequate                | Increase supply pressure and/or flow.  |
|  | One channel of valve is not functioning  | Check 'Valve does not open' symptoms above   |
| Valve is slow to vent protected system       | Inadequate flow area in protected system | Revise flow in protected system  |
|  | One channel of valve is not functioning  | Check 'Valve does not close' symptoms above  |

Note: If one channel fails in a duplex valve, replace the entire unit.

Table 14.

## 7 Limitations of Use

### Danger

- The machine designer is responsible for ensuring that the operation of this device is compatible with relevant safety regulations.
- Fitting a soft start device does not contribute to human risk reduction.
- The limited flow phase and the transition to full flow might cause unpredictable machine movements.

### Warning

The system designer should determine the effect of the possible failure modes of the product on the system.

#### 7.1 Limited warranty and disclaimer/compliance requirements

Refer to Handling Precautions for SMC Products.

#### 7.2 Unexpected start-up

In the event of the loss of supply pressure, the electrical supplies to the solenoid valves shall be removed to avoid the potential for an unexpected start-up when the supply pressure is restored.

#### 7.3 Holding of pressure

Since valves are subject to air leakage, they cannot be used for applications such as holding pressure (including vacuum) in a system.

#### 7.4 Safety relays or PLC

- A safe output from a safety relay or PLC is used to operate this valve, ensure that any output test pulse duration is shorter than 1 ms to avoid the valve solenoid responding.
- The diagnostic switches should be wired to the safety input of the PLC.

### Caution

#### 7.5 Leakage voltage

Ensure that any leakage voltage caused by the leakage current when the switching element is OFF causes  $\leq 3\%$  of the rated voltage across the valve.

#### 7.6 Low temperature operation

Unless otherwise indicated in the specifications for each valve, operation is possible to  $-10^{\circ}\text{C}$ , but appropriate measures should be taken to avoid solidification or freezing of drainage and moisture, etc.

#### 7.7 EMC Restrictions

##### 7.7.1 Class and group description

- This product is group 1, class A equipment according to EN55011.
- Group 1 equipment does not intentionally generate radio-frequency energy in the range 9kHz to 400 GHz.

## 7 Limitations of Use - continued

- Class A equipment is equipment suitable for use in all locations other than those allocated in residential environments and those directly connected to a low voltage power supply network which supplies buildings used for domestic purposes.
- This equipment is not intended for use in residential environments and may not provide adequate protection to radio reception in such environments.

#### 7.7.2 Cable length to connect

The cable to connect the product shall be less than or equal to 30m.

#### 7.7.3 Connecting the power supply

This product is not intended to be directly connected to any DC Distribution network.

#### 7.8 Limitations

### Caution

- Please note that if the operating pressure falls below 0.25 MPa due to the pressure drop caused by insufficient air supply capacity, it may not switch properly.
- This product is CE/UKCA marked as a safety component as defined under the Machinery Directive 2006/42/EC / The Supply of Machinery (safety) Regulations 2008. For details, please refer to the Declaration of Conformity supplied with the product.
- The valve may only be used to provide the stated safety function for the supply and removal of pressure from all or part of a pneumatic system, under the total control of a supervisory device. The valve can only perform as a safety component when properly installed in a system conforming to the appropriate safety standards.
- Any such use must be within the specified limits and application conditions for the product.
- In order to meet a required performance level as defined by the appropriate safety standard, the user must provide all the other necessary components to complete function of the safety system.
- The user is responsible for the specification, design, implementation, validation and maintenance of the safety system.

## 8 Product Disposal

This product shall not be disposed of as municipal waste. Check your local regulations and guidelines to dispose this product correctly, in order to reduce the impact on human health and the environment.

## 9 Contacts

Refer to [www.smcworld.com](https://www.smcworld.com) or [www.smc.eu](https://www.smc.eu) for your local distributor/importer.

# SMC Corporation

URL : <https://www.smcworld.com> (Global) <https://www.smc.eu> (Europe)  
SMC Corporation, 4-14-1, Sotokanda, Chiyoda-ku, Tokyo 101-0021, Japan  
Specifications are subject to change without prior notice from the manufacturer.  
© SMC Corporation All Rights Reserved.  
Template DKP50047-F-085N