

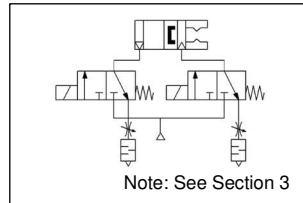

ORIGINAL INSTRUCTIONS

Instruction Manual

Air Gripper for Collaborative Robots RMHZ Series

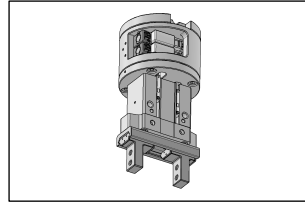

Note: See Section 3

The intended use of this parallel type of air gripper is to convert the potential energy provided by compressed air into a force which causes mechanical linear motion of the fingers.

1 Safety Instructions

These safety instructions are intended to prevent hazardous situations and/or equipment damage. These instructions indicate the level of potential hazard with the labels of "Caution," "Warning" or "Danger." They are all important notes for safety and must be followed in addition to International Standards (ISO/IEC)¹⁾, and other safety regulations.
¹⁾ ISO 4414: Pneumatic fluid power - General rules relating to systems.
 ISO 4413: Hydraulic fluid power - General rules relating to systems.
 IEC 60204-1: Safety of machinery - Electrical equipment of machines. (Part 1: General requirements)
 ISO 10218-1: Robots and robotic devices - Safety requirements for industrial robots - Part 1: Robots.

- Refer to product catalogue, Operation Manual and Handling Precautions for SMC Products for additional information.
- Keep this manual in a safe place for future reference.

	Caution	Caution indicates a hazard with a low level of risk which, if not avoided, could result in minor or moderate injury.
	Warning	Warning indicates a hazard with a medium level of risk which, if not avoided, could result in death or serious injury.
	Danger	Danger indicates a hazard with a high level of risk which, if not avoided, will result in death or serious injury.

Warning

- **Always ensure compliance with relevant safety laws and standards.**
- All work must be carried out in a safe manner by a qualified person in compliance with applicable national regulations.

2 Specifications

2.1 Product Specifications

Installation Standard		Compliant with ISO9409-1-50-4-M6 ¹⁾
Fluid		Air
Operating Pressure [MPa]		0.1 to 0.7
Ambient and Fluid Temperature [C]		-10 to +50 ²⁾
Repeatability [mm]		± 0.01
Maximum Operating Frequency [c.p.m.]		120
Lubrication		Non-Lube
Action		Double Acting
Gripping Force (/per finger) ³⁾	External Force [N]	54.2
	Internal Force [N]	72.2
Opening/Closing Stroke [mm]		14
Weight [g] ⁴⁾		638
Connector configuration		M8 8-Pin (Plug)
Air Supply Port		One Touch Fittings (φ4)
Supply Voltage		DC 24V ± 10% ²⁾

Note 1) Robots whose end effector mounting standard differs are equipped with a dedicated mounting flange.

Note 2) When the compatible robot is KUKA's LBR-iiwa, the power supply voltage is DC 24V (-15%/+20%) and the maximum operating temperature is 40°C.

2 Specifications (continued)

Note 3) Values taken at the centre of stroke, when the pressure is 0.5 MPa and the gripping point distance L is 20 mm.

Note 4) Value excludes weights of the protective cover, finger attachment, and cable with connector.

2.2 Individual Models:

Solenoid valve	V114
Auto switch	D-M9N / D-M9P
Exhaust throttle valve	ASN2-M5-X937

Warning

Special products (-X) might have specifications different from those shown in this section. Contact SMC for specific drawings.

3 Installation

3.1 Installation

Warning

- Do not install the product unless the safety instructions have been read and understood.
- When installing the product, consider and allow access for maintenance.
- Do not scratch or dent the air gripper, by dropping or bumping it when mounting. Deformation to the product can cause inaccuracies in operation or a malfunction.
- Tighten to a value within the specified torque range when mounting the attachment. Excessive tightening can cause malfunction, and insufficient tightening can cause slippage and dropping.

3.1.1 Mounting the Product

- Insert parallel pins to the pin holes of the robot tool flange.
- Insert the parallel pins by aligning them with the long holes of the main plate assembly. Mount the main plate onto the robot with the supplied clamber bolts.
- Check that the clamber bolts on the main plate are loosened and align the claspers with the flange grooves on the air gripper side.
- Tighten the clamber bolts to mount the air gripper.

Bolt	Size	Width Across Flats	Tightening Torque
Hexagon Thin Socket Head Bolt	M6 x 1.0	4	5.2 ± 0.5 N.m
Clamber Bolts	M5 x 0.8	3	3.0 ± 0.3 N.m

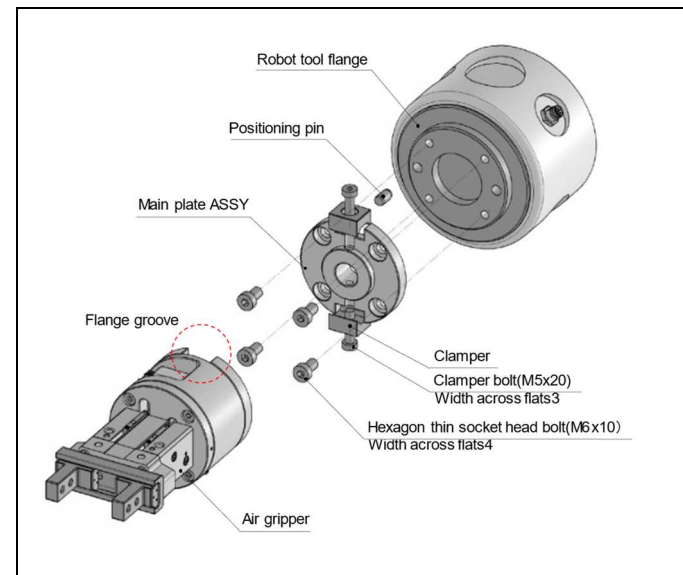

Note: Installation of dedicated flange (identification symbol: 031N, 031P, 041N, 041P, 042N, 042P). Before mounting the main plate ASSY, mount the dedicated flange.

3 Installation (continued)

3.1.1.1 Flange dedicated to Mitsubishi Electric

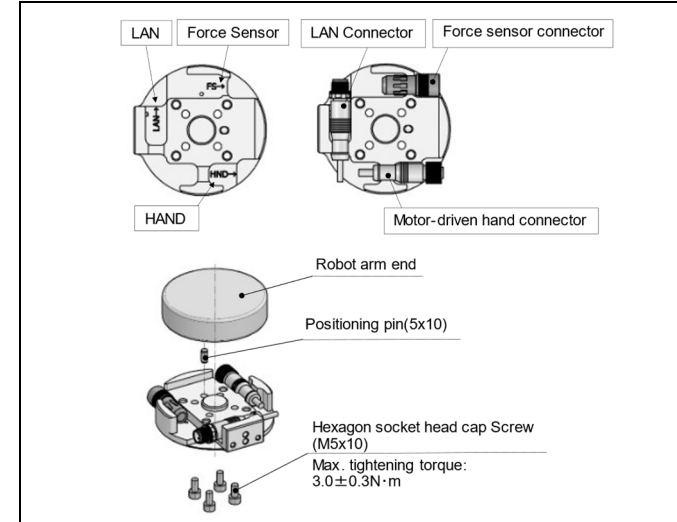

3.1.1.2 Flange dedicated to YASKAWA Electric

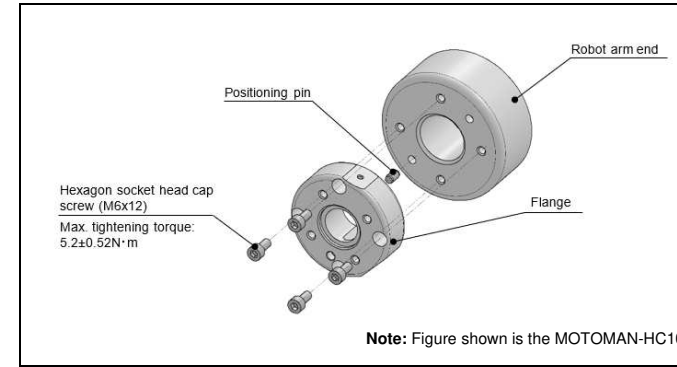

3.1.1.3 Mounting the Protective Cover

- When attaching or detaching a finger attachment, use the tightening torque shown below.

Bolt	Maximum Tightening Torque
M3 x 0.5	0.63 ± 0.06 N.m

3.1.2 Connector and Pin Layout

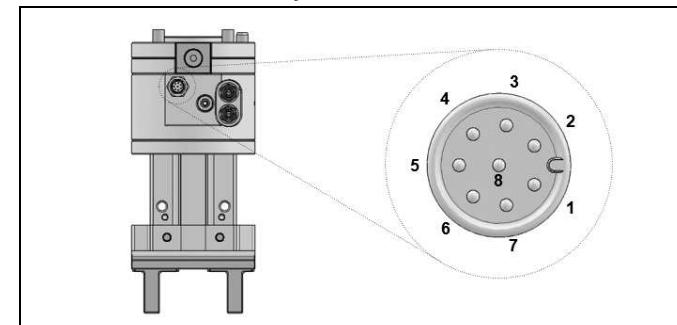

3.1.2.1 Universal Robots (011P), Yaskawa Electric (043N), DTP Series (043P), FANUC (051P), SIASUN (081P) and ABB (0121P).

PIN #	Function	Description
1	-	Unused
2	-	Unused
3	Auto switch (Finger Closing Direction)	-
4	Auto switch (Finger Opening Direction)	-
5	+24 V	Power Supply 24 VDC
6	Valve 2 On/Off	-
7	Valve 1 On/Off	-
8	Ground (GND)	Power Supply 0 VDC

3 Installation (continued)

3.1.2.2 Techman, Omron (021N)

PIN #	Function	Description
1	+24 V	Power Supply 24 VDC
2	Auto switch (Finger Opening Direction)	-
3	Auto switch (Finger Closing Direction)	-
4	-	Unused
5	Valve 1 On/Off	-
6	Valve 2 On/Off	-
7	-	Unused
8	Ground (GND)	Power Supply 0 VDC

3.1.2.3 Mitsubishi Electric (0131N, 0131P)

PIN #	Function	Description
1	Ground (GND)	Power Supply 0 VDC
2	+24 V	Power Supply 24 VDC
3	Valve 1 On/Off	-
4	Valve 2 On/Off	-
5	Auto switch (Finger Closing Direction)	-
6	Auto switch (Finger Opening Direction)	-
7	-	Unused
8	-	Unused

3.1.2.4 Yaskawa Electric (041N, 041P, 042N, 042P)

PIN #	Function	Description
1	+24 V	Power Supply 24 VDC
2	Ground (GND)	Power Supply 0 VDC
3	Valve 1 On/Off	-
4	Valve 2 On/Off	-
5	Auto switch (Finger Opening Direction)	-
6	Auto switch (Finger Closing Direction)	-
7	-	Unused
8	-	Unused

3.1.2.5 KUKA (061P)

PIN #	Function	Description
1	+24 V	Power Supply 24 VDC
2	-	Unused
3	Auto switch (Finger Opening Direction)	-
4	Auto switch (Finger Closing Direction)	-
5	Valve 1 On/Off	-
6	Valve 2 On/Off	-
7	-	Unused
8	Ground (GND)	Power Supply 0 VDC

3.1.2.6 Doosan Robotics (071P)

PIN #	Function	Description
1	Auto switch (Finger Opening Direction)	-
2	Valve 1 On/Off	-
3	Valve 2 On/Off	-
4	-	Unused
5	+24 V	Power Supply 24 VDC
6	-	Unused
7	Auto switch (Finger Closing Direction)	-
8	Ground (GND)	Power Supply 0 VDC

3.1.2.7 JAKA (091N, 091P)

PIN #	Function	Description
1	+24 V	Power Supply 24 VDC
2	Auto switch (Finger Opening Direction)	-
3	Auto switch (Finger Closing Direction)	-
4	Valve 1 On/Off	-
5	Valve 2 On/Off	-
6	-	Unused
7	-	Unused
8	Ground (GND)	Power Supply 0 VDC

3 Installation (continued)

3.1.2.8 AUBO (101N)

PIN #	Function	Description
1	Ground (GND)	Power Supply 0 VDC
2	+24 V	Power Supply 24 VDC
3	Auto switch (Finger Opening Direction)	-
4	Auto switch (Finger Closing Direction)	-
5	Valve 1 On/Off	-
6	-	Unused
7	Valve 2 On/Off	-
8	-	Unused

3.1.2.9 HAN'S ROBOT (111N)

PIN #	Function	Description
1	Auto switch (Finger Opening Direction)	-
2	Auto switch (Finger Closing Direction)	-
3	-	Unused
4	Valve 1 On/Off	-
5	Valve 2 On/Off	-
6	-	Unused
7	-	Unused
8	-	Unused
9	-	Unused
10	-	Unused
11	+24 V	Power Supply 24 VDC
12	Ground (GND)	Power Supply 0 VDC

3.1.3 Internal Circuit Diagrams

Universal Robots (011P) Switch Output: PNP Valve: +COM 	Omron/Techman (021N) Switch Output: NPN Valve: +COM
Mitsubishi Electric (031N) Switch Output: NPN Valve: +COM 	Mitsubishi Electric (031P) Switch Output: PNP Valve: -COM
Yaskawa Electric (041N,042N) Switch Output: NPN Valve: +COM 	Yaskawa Electric (041P,042P) Switch Output: PNP Valve: -COM

3 Installation (continued)

Yaskawa Electric (043N) Switch Output: NPN Valve: +COM 	Yaskawa Electric (043P) Switch Output: PNP Valve: -COM
FUNAC (051P) Switch Output: PNP Valve: +COM 	KUKA (061P) Switch Output: PNP Valve: -COM
Doosan (071P) Switch Output: PNP Valve: -COM 	SIASUN (081P) Switch Output: PNP Valve: -COM

JAKA (091N) Switch Output: NPN Valve: +COM 	JAKA (091P) Switch Output: PNP Valve: -COM
AUBO (101N) Switch Output: NPN Valve: +COM 	HAN'S ROBOT (111P) Switch Output: PNP Valve: +COM
ABB (121P) Switch Output: PNP Valve: +COM 	

3 Installation (continued)

3.2 Environment



Warning

- Do not use in an environment where corrosive gases, chemicals, salt water or steam are present.
- Do not use in an explosive atmosphere.
- Do not expose to direct sunlight. Use a suitable protective cover.
- Do not install in a location subject to vibration or impact.
- Do not mount in a location exposed to radiant heat that would result in temperatures in excess of the product's specifications.
- Do not use this product in a dusty environment, or in an environment in which water or oil can splash onto the product.

3.3 Piping



Caution

- Before connecting piping make sure to clean up chips, cutting oil, dust etc.
- When installing piping or fittings, ensure sealant material does not enter inside the port. When using seal tape, leave 1 thread exposed on the end of the pipe/fitting.
- Connect tubing with outer diameter Ø4mm to the air supply port. To remove the tubing, press the release button and pull.

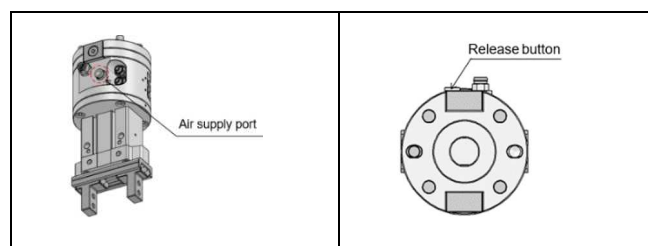

3.4 Pneumatic Circuit Diagram

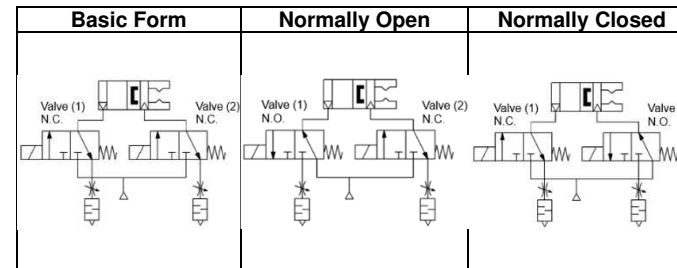

3.5 Wiring

- When installing and securing the cable between the air gripper and the tool flange, do not energise the product.
- Ensure that the connect is secure before operating to prevent it becoming loose.

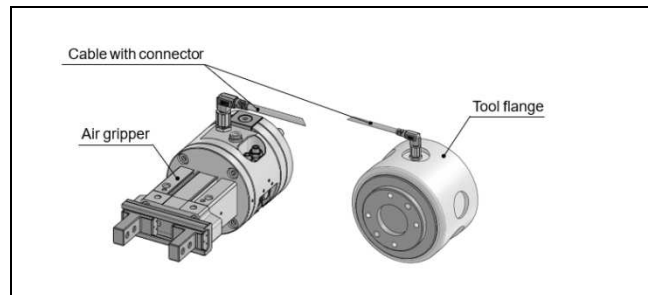

3.6 Lubrication



Caution

- SMC products have been lubricated for life at manufacture, and do not require lubrication in service.
- If a lubricant is used in the system, refer to catalogue for details.

4 Settings

4.1 Finger Opening/Closing Speed Adjustment

- Use a flat blade screwdriver for adjusting the metering valves.
- Ensure that the restriction of the two metering valves is approximately the same. If they differ too much, the operation can become unstable.

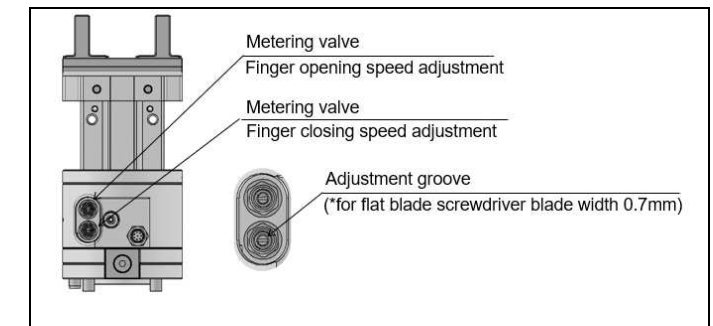

4.2 Relationship between Valve ON/OFF and Gripper Action

Energization state of valve		Gripper action		
Solenoid valve (1)	Solenoid valve (2)	Basic type	Normal open	Normal close
OFF	OFF	No pressure applied *1	Finger opening	Finger closing
ON	OFF	Finger opening	No pressure applied *1	Pressure applied to both sides *2
OFF	ON	Finger closing	Pressure applied to both sides *2	No pressure applied *1
ON	ON	Pressure applied to both sides *2	Finger closing	Finger opening

Note 1) When no pressure is applied, there is no air pressure on either the open or close side of the piston, therefore the fingers can be moved by hand.

Note 2) When pressure is applied to both sides, air is on both sides of the piston, however due to the construction there will be a small force generated in the closing direction.

5 How to Order

Refer to product catalogue for 'How to Order'.

R MHZ 2 - 20 D - 011 P O - N D E		① ② ③ ④ ⑤ ⑥	
① Supported robots	② Switch selection	③ Valve Options	
Refer to the table of compatible robots.	N Auto switch(NPN) P Auto switch(PNP)	Nil. basic form O Normal open C Normal close	
④ Robot connection cable	⑤ Protection cover	⑥ Manual changer	
Nil. With connector N Cable included	Nil. Without cover D With cover	E With main plate ASSY F Without main plate ASSY	

Compatible robot

Symbol	Robot manufacturer	Supported models	Switch output	Valve polarity
011P	UNIVERSAL ROBOTS	UR3(e)	PNP	+COM
		UR5(e)		
		UR10(e)		
		UR16e		
021N	OMRON TECHMAN ROBOT	TM5	NPN	+COM
		TM12		
		TM14		
031N	Mitsubishi Electric	MELFA ASSISTA (RV-5AS-D)	NPN	+COM
031P			PNP	-COM

Symbol	Robot manufacturer	Supported models	Switch output	Valve polarity		
041N	YASKAWA Electric	MOTOMAN-HC10	NPN	+COM		
041P			PNP	-COM		
042N		MOTOMAN-HC10DT	NPN	+COM		
042P			PNP	-COM		
043N		MOTOMAN-HC10DTP MOTOMAN-HC20SDTP MOTOMAN-HC20DTP MOTOMAN-HC10DTP MOTOMAN-HC20SDTP MOTOMAN-HC20DTP		NPN	+COM	
043P				PNP	-COM	
051P	FANUC			CRX-5iA	PNP	+COM
				CRX-10iA(L)		
				CRX-20iA		
		CRX-25iA				
061P	KUKA	LBR-iiwa (media flange : I/O Pneumatic only)	PNP	-COM		
071P	Doosan Robotics	H2017	PNP	-COM		
		H2515				
		M0609				
		M0617				
		M1013				
		M1509				

6 Outline Dimensions

Refer to product catalogue for outline dimensions.

7 Maintenance

7.1 General maintenance

Caution

- Not following proper maintenance procedures could cause the product to malfunction and lead to equipment damage.
- If handled improperly, compressed air can be dangerous.
- Maintenance of pneumatic systems should be performed only by qualified personnel.
- Before performing maintenance, turn off the power supply and be sure to cut off the supply pressure. Confirm that the air is released to atmosphere.
- After installation and maintenance, apply operating pressure and power to the equipment and perform appropriate functional and leakage tests to make sure the equipment is installed correctly.
- If any electrical connections are disturbed during maintenance, ensure they are reconnected correctly and safety checks are carried out as required to ensure continued compliance with applicable national regulations.
- Do not make any modification to the product.
- Do not disassemble the product, unless required by installation or maintenance instructions.

Warning

- When air grippers are removed for maintenance, first confirm that measures are in place to prevent any workpieces from dropping, run-away of equipment. Then cut off the supply pressure and electric power and exhaust all compressed air from the system using the residual pressure release function. When the equipment is restarted, proceed with caution after confirming that appropriate measures are in place to prevent cylinders from sudden movement.
- Do not allow people to enter or place objects in the carrying path of the air gripper.
- Do not put hands in between the air gripper fingers or attachments.

7.2 Procedure for replacing Gripper

- Loosen the hexagon socket head cap screws (M4x0.8) and remove the flange and gripper assembly, from the module base.
- Loosen the screws of the auto switches and remove the auto switches from the gripper.
- Loosen the hexagon socket head cap screws (M5x1.0) which secure the gripper and remove the gripper assembly.
- Replace the gripper and mount the dismantled parts by following the above steps in the reverse order.

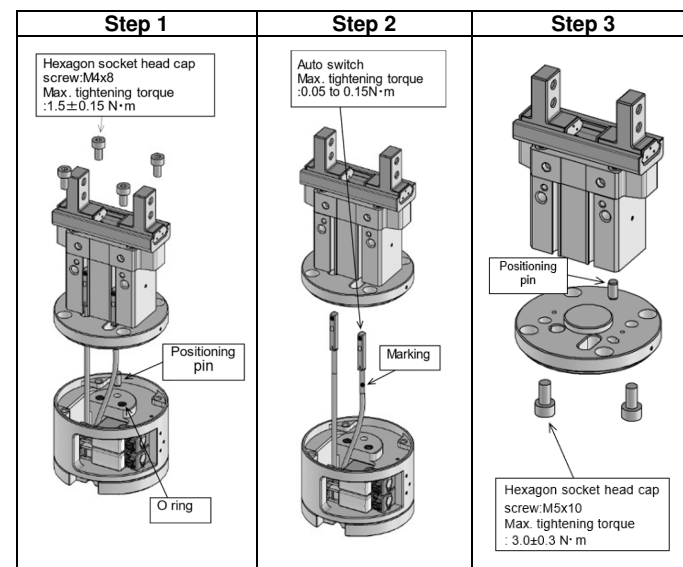

Caution

- When disassembly the product, take care not to lose the positioning pin and the O-ring.
- The two auto switches have a specific switch groove for installation. When installing the switches, fix them as shown above.

7 Maintenance (continued)

7.3 Procedure for replacing Auto Switch

- Loosen the hexagon socket head cap screws (M4x0.8) and remove the flange and gripper assembly, from the module base.
- Loosen the screws of the auto switches and remove the auto switches from the gripper.
- Loosen the hexagon socket head cap screw (M4x0.8) and remove the tool plate from the module base.
- Take the auto switches out from the tool plate side to the extent that the connector of the substrate in the module base is visible.
- Replace the auto switch assembly by disconnecting the connector and mount the dismantled parts by following the above steps in the reverse order.

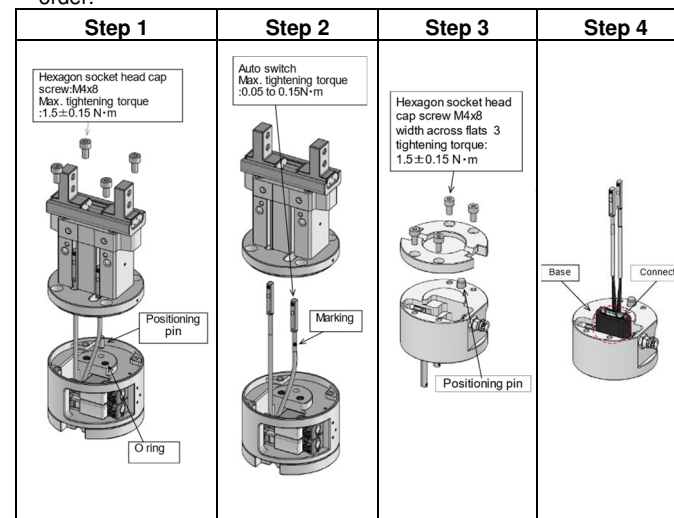

Caution

- When disassembly the product, take care not to lose the positioning pin and the O-ring.

7.4 Procedure for replacing the solenoid valve (Basic Type)

- Loosen the cross recessed head machine screw (M1.5) and take the solenoid valve out.
- Replace the valve by disconnecting the connector and mount the dismantled parts by following the above step.

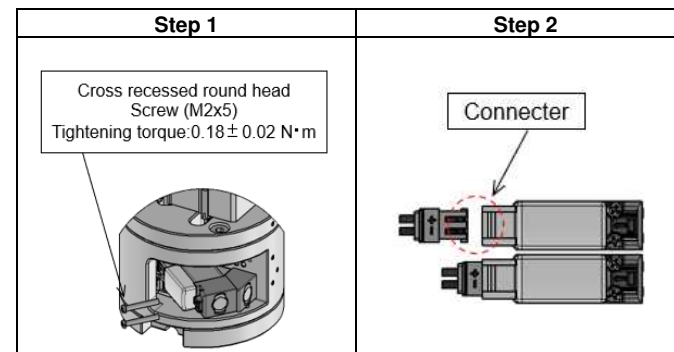

Caution

- A gasket is mounted on the solenoid valve. Take care not to lose the gasket or have dirt attach on it at the time of replacement.
- Mount the solenoid valve while placing the cable with a marking to be below the other cable.

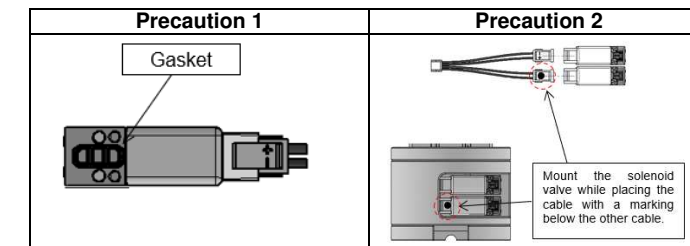

7 Maintenance (continued)

7.4 Procedure for replacing the solenoid valve (Normally Open, Normally Closed)

In the normally open or normally closed version, a piping block is assembled between the valve on one side and the module base. The valve on the side with the piping block should be replaced with V124-5MOU and the valve on the other side with V114-5MOU. The replacement procedure is the same as for the basic type.

- Remove the valve by following the same procedures as those for basic type.
- Mount a gasket on the piping block, and secure the block to the module base.
- *1 While moving the piping block in the direction indicated by the arrow in the figure below, secure it with screws.
- Mount the connector to the valve, and install the valve on top of the piping block.

Symbol	Robot manufacturer	Supported models	Switch output	Valve polarity
081P	SIASUN	SCR3	PNP	-COM
		SCR5		
		GCR3-620		
		GCR5-910		
		GCR10-1300		
		GCR14-1400		
		GCR20-1100		
091N	JAKA	JAKA Zu3	NPN	+COM
		JAKA Zu7		
		JAKA Zu12		
091P	JAKA	JAKA Zu3	PNP	-COM
		JAKA Zu7		
		JAKA Zu12		
101N	AUBO	AUBO-i3	NPN	+COM
		AUBO-i5		
		AUBO-i10		
111P	HAN'S ROBOT	E03	PNP	-COM
		E05		
		E10		
121P	ABB	Gofa	PNP	-COM

*Please contact our nearest sales office for the compatibility with robots not listed in the compatible robot list.

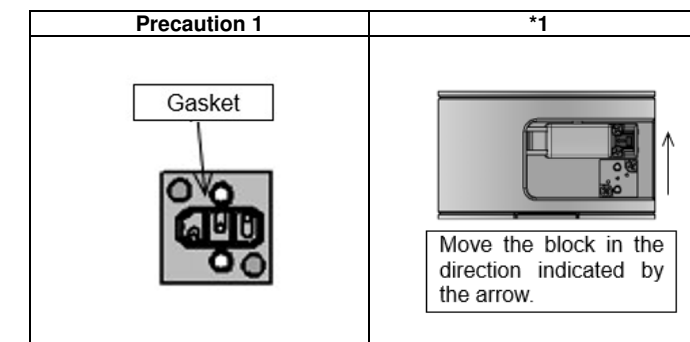
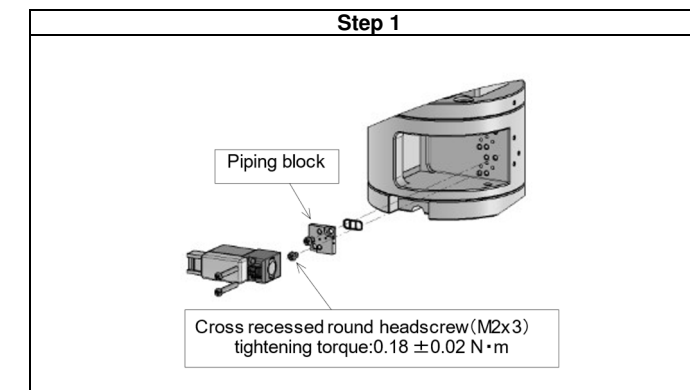

Caution

- When installing the gasket on the piping block, pay attention not to have dirt attach to it.
- Mount the solenoid valve while placing the cable with a marking to be below the other cable.

7.5 Solenoid Valve Part Numbers

	Valve 1	Valve 2
Basic Form	V114-5MOU	V114-5MOU
Normally Open	V124-5MOU + Piping block assembly	V114-5MOU
Normally Closed	V114-5MOU	V124-5MOU + Piping block assembly

8 Limitations of Use

8.1 Limited warranty and disclaimer/compliance requirements

Refer to Handling Precautions for SMC Products.

Warning

- Do not operate this product at specifications beyond what has been specified, as this can cause damage and/or malfunction to the product.
- Do not allow people to enter or place objects in the carrying path of the air gripper. Otherwise, injury or accident may occur.
- Do not put hands in between the air gripper fingers or attachments. It is the end-user's responsibility to take relevant safety measures e.g. protective covers to prevent this.
- There is a danger that workpieces may be dropped if there is a reduction in gripping force, caused by a power failure. It is the end-user's responsibility to take measures to prevent drop prevention which can lead to injury, or damage to machinery or equipment.
- If the product is used for any purpose other than the transportation of a workpiece such positioning of clamping, please consult SMC.

9 Product Disposal

This product shall not be disposed of as municipal waste. Check your local regulations and guidelines to dispose this product correctly, in order to reduce the impact on human health and the environment.

10 Contacts

Refer to www.smcworld.com or www.smc.eu for your local distributor/importer.

SMC Corporation

URL : [https:// www.smcworld.com](https://www.smcworld.com) (Global) <https:// www.smc.eu> (Europe)
 SMC Corporation, 4-14-1, Sotokanda, Chiyoda-ku, Tokyo 101-0021, Japan
 Specifications are subject to change without prior notice from the manufacturer.
 © 2022 SMC Corporation All Rights Reserved.
 Template DKP50047-F-085M