



ORIGINAL INSTRUCTIONS

**Instruction Manual**  
**Digital Flow Switch – Remote Monitor unit**  
**PF3W30# series**



The intended use of the digital flow switch is to monitor and display flow information from remote sensors and provide an output signal.

**1 Safety Instructions**

These safety instructions are intended to prevent hazardous situations and/or equipment damage. These instructions indicate the level of potential hazard with the labels of "Caution," "Warning" or "Danger." They are all important notes for safety and must be followed in addition to International Standards (ISO/IEC)<sup>1)</sup>, and other safety regulations.

<sup>1)</sup>ISO 4414: Pneumatic fluid power - General rules and safety requirements for systems and their components.

ISO 4413: Hydraulic fluid power - General rules and safety requirements for systems and their components.

IEC 60204-1: Safety of machinery - Electrical equipment of machines - Part 1: General requirements.

ISO 10218-1: Robotics - Safety requirements - Part 1: Industrial robots.

- Refer to product catalogue, Operation Manual and Handling Precautions for SMC Products for additional information.
- Keep this manual in a safe place for future reference.

<b>Danger</b>	Danger indicates a hazard with a high level of risk which, if not avoided, will result in death or serious injury.
<b>Warning</b>	Warning indicates a hazard with a medium level of risk which, if not avoided, could result in death or serious injury.
<b>Caution</b>	Caution indicates a hazard with a low level of risk which, if not avoided, could result in minor or moderate injury.

**Warning**

- **Always ensure compliance with relevant safety laws and standards.**
- All work must be carried out in a safe manner by a qualified person in compliance with applicable national regulations.
- This product is class A equipment intended for use in an industrial environment. There may be potential difficulties in ensuring electromagnetic compatibility in other environments due to conducted or radiated disturbances.
- Refer to the operation manual on the SMC website (URL: <https://www.smcworld.com>) for more safety instructions.

**2 Specifications**

Model	PF3W30#				
	PF3W 504	PF3W 520	PF3W 540	PF3W 511	PF3W 521
Applicable sensor	PF3W 504	PF3W 520	PF3W 540	PF3W 511	PF3W 521
Rated flow range	0.5 to 4 L/min	2 to 16 L/min	5 to 40 L/min	10 to 100 L/min	50 to 250 L/min
Display flow range	0.35 to 4.50 L/min	1.7 to 18.0 L/min	3.5 to 45.0 L/min	7 to 112 L/min	20 to 280 L/min
Switch point range	0.35 to 4.50 L/min	1.7 to 18.0 L/min	3.5 to 45.0 L/min	7 to 112 L/min	20 to 280 L/min
Minimum setting unit	0.01 L/min	0.1 L/min		1 L/min	2 L/min
Conversion of accumulated pulse (Pulse width = 50 ms)	0.05 L/pulse	0.1 L/pulse	0.5 L/pulse	1 L/pulse	2 L/pulse
Display unit	L/min for real-time flow and L for accumulated flow				
Accuracy	±3% F.S.				
Repeatability	±2% F.S.				
Temperature characteristics	±5% F.S. max. (25 °C reference)				
Operating pressure range	Refer to graph of operating pressure and proof pressure				
Proof pressure	Refer to graph of operating pressure and proof pressure				
Pressure loss	Refer to graph of pressure loss				
Accumulated flow range	99999999.9 L		999999999 L		
	By 0.1 L	By 0.5 L	By 1 L		
Switch output	NPN or PNP open collector output				
Max. load current	80 mA				
Max. applied voltage	28 V				
Internal voltage drop	NPN: 1.0 V or less (Load current 80 mA) PNP: 1.5 V or less (Load current 80 mA)				
Response time	1 s / 2 s				
Output protection	Short circuit protection				
Output mode	Flow	Select one of output (hysteresis or window comparator mode), output for the accumulated flow and the accumulated pulse output.			
	Temp.	Select the output for fluid temperature (hysteresis mode or window comparator mode).			
Response time	1 s / 2 s				
Analogue output	Voltage output	Output voltage: 1 to 5 V, Output impedance: 1 kΩ			
	Current output	Output current: 4 to 20 mA Max. load impedance: 300 Ω for 12 VDC, 600 Ω for 24 VDC			
Hysteresis	Variable from 0				
External Input	Voltage free input of 0.4 V or less (reed or solid state type) for 30 ms or longer				
Input / output	Input for copy mode				

**2 Specifications (continued)**

Model	PF3W30#	
Display method	2-screen display (main screen, sub screen) Main screen: 4-digit, 7-segment, 2-colour, red/green Sub screen: 6-digit, 11-segment, white Display update frequency 5 times/sec.	
Indicator light	Output 1 and 2: Orange	
Power Supply voltage	12 to 24 VDC ±10%, including ripple (p-p)	
Current consumption	50 mA max.	
Environment	Enclosure	IP40 (front panel display is IP65 when using optional panel mount adapter and front protective cover)
	Operating temp. range	0 to 50 °C (no freezing and condensation)
	Operating humidity range	Operation, Storage: 35 to 85%R.H. (no condensation)
	Withstand voltage	1000 VAC, for 1 minute between terminals and housing
Insulation resistance	50 MΩ min. (with 500 VDC) between terminals and housing	
Weight without lead wire	50 g	
Weight with lead wire	100 g	

**Warning**

- Special products (-X) might have specifications different from those shown in this section. Contact SMC for specific drawings.

**3 Names of individual parts**

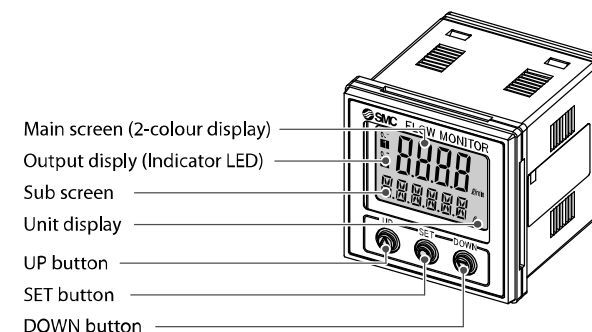

Element	Description
Main screen (2-colour display)	Displays the flow, status of setting mode and error code.
Sub screen	Displays the accumulated flow, set value, peak/bottom value, fluid temperature and line names.
Output display (Indicator LED)	Displays the output status of OUT1 and OUT2. When ON: Orange LED is ON.
Unit display	Displays the unit selected.
UP button	Selects a mode and the display shown at the sub screen, and increases the ON/OFF set values.
SET button	Press this button to select mode and to confirm a set value.
DOWN button	Selects a mode and the display shown at the sub screen, and decreases the ON/OFF set values.

**4 Installation**

**4.1 Installation**

**Warning**

- Do not install the product unless the safety instructions have been read and understood.
- Use the product within the specified operating pressure and temperature range.
- Proof pressure could vary according to the fluid temperature. Check the characteristics data for operating pressure and proof pressure.

**4.2 Environment**

**Warning**

- Do not use in an environment where corrosive gases, chemicals, salt water or steam are present.
- Do not use in an explosive atmosphere.
- Do not expose to direct sunlight. Use a suitable protective cover.
- Do not install in a location subject to vibration or impact in excess of the product's specifications.
- Do not mount in a location exposed to radiant heat that would result in temperatures in excess of the product's specifications.

**4.3 Mounting with panel mount adapter**

- The flow monitor can be fixed to the panel with the panel mount adapter using the screws supplied M3 x 8 L (2 pcs.). Panel mount adapter (Part number: ZS-26-B) Front protective cover (Part number: ZS-26-01)
- The panel mount adapter can be rotated through 90 degrees for mounting.
- The panel mount adapter should be fixed firmly with screws. Otherwise, fluids such as water may enter. After contact with the panel, tighten screws by 1/4 to 1/2 turn.

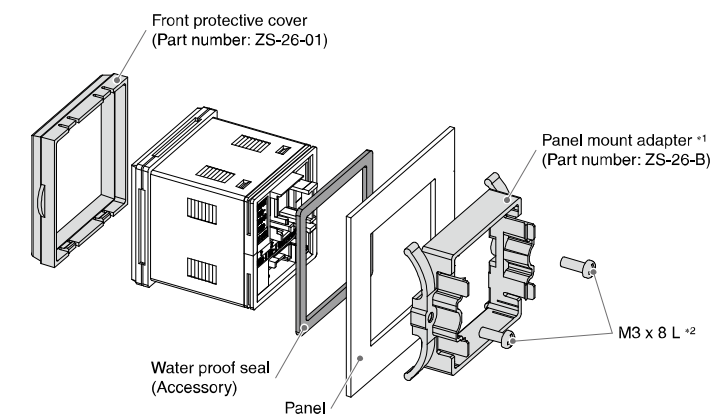

**4.4 Removal of pane mount adapter**

The flow monitor with panel mount adapter can be removed from the panel after removing the two screws, and by disconnecting the hooks on both sides. This can be done by inserting a suitable piece of thin card. Pull the panel mount adapter to the front and remove the flow monitor. If the panel mount adapter is pulled forward with the hook caught, the product and the adapter may be damaged.

## 4 Installation (continued)

### 4.5 Wiring

#### Caution

- Do not perform wiring while the power is on.
  - Confirm proper insulation of wiring.
  - Do not route wires and cables together with power or high voltage cables.
- Otherwise the product can malfunction due to interference of noise and surge voltage from power and high voltage cables to the signal line.
- Keep wiring as short as possible to prevent interference from electromagnetic noise and surge voltage.
  - Ensure that the FG terminal is connected to ground when using a commercially available switch-mode power supply.
- Switching noise will be superimposed and the product specification can no longer be met. This can be prevented by inserting a noise filter, such as a line noise filter and ferrite core, between the switch-mode power supply and the product, or by using a series power supply instead of a switch-mode power supply.

#### Connection of Sensor and Power supply connectors

- When connecting, insert the connectors straight into the body until it clicks.
- To remove the connectors, push the lever downward with your thumb, and pull the connectors out straight.

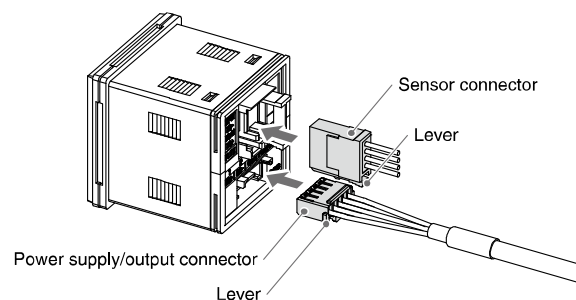

### 4.6 Sensor Connector

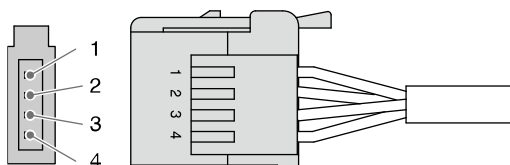

Pin No.	Description	Wire colour
1	DC(+)	Brown
2	N.C. / temperature analogue input (1 to 5 V)	White
3	DC(-)	Blue
4	flow analogue input (1 to 5 V)	Black

#### Wiring of the Sensor connector

- Strip the sensor lead wire as shown in the figure.
- (Refer to the following table for the connector and applicable wire). Do not cut the insulator.

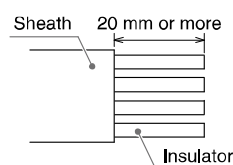

SMC part No. (1 pc.)	Colour of cover	Insulator outside diameter
ZS-28-CA-4 (option)	Blue	φ1.15 to φ1.35
ZS-28-C-1	Yellow	φ1.0 to φ1.2

## 4 Installation (continued)

- The core of the corresponding colour shown in the table below is put into the pin of the number marked on the connector for sensor connection.

Pin No.	Wire colour *
1	Brown
2	White
3	Blue
4	Black

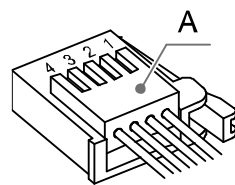

\* When using the lead wire with M8 connector included with the PF3W5 series.

- Ensure that the above-mentioned preparation work has been performed correctly, and press part "A" by hand to make temporary connection.
- Press part "A" centre straight in using a suitable tool, such as pliers.
- The sensor connector cannot be re-used once crimped.
- For a connection failure such as incorrect order of wire or incomplete insertion, use a new connector.
- When the sensor is not connected correctly, "LLL" will be displayed.

### 4.7 Power Supply Connector

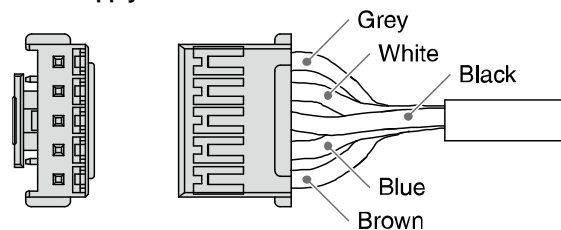

Description	Wire colour
COPY	Grey
OUT2	White
OUT1	Black
DC(-)	Blue
DC(+)	Brown

## 5 Flow Setting

### 5.1 Measurement mode

The mode in which the flow is detected and displayed, and the switch function is operating. This is the basic operating mode; other modes should be selected for set-point and other function setting changes.

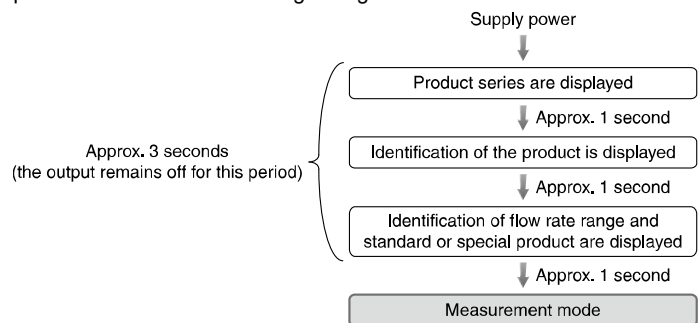

### 5.2 Switch operation

When the flow exceeds the set value, the switch will be turned ON. When the flow falls below the set value by the amount of hysteresis or more, the switch will be turned OFF. If the operation shown is acceptable, keep this setting.

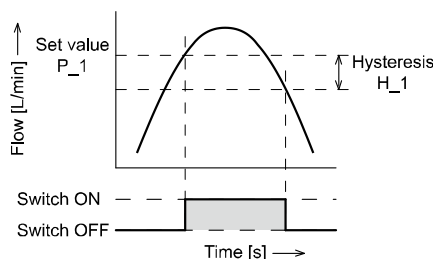

## 6 3-step Setting mode

- Be sure to select the required sensor to be connected.
- 1. Press the SET button in measurement mode to display set values. [P\_1] or [n\_1] and the set value are displayed alternately.

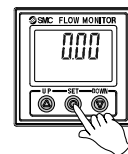

- 2. Press the UP or DOWN button to change the set value. The UP button is to increase and the DOWN button is to decrease.

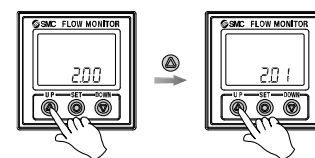

- Press the UP button once to increase by one digit, or press and hold to continuously increase.

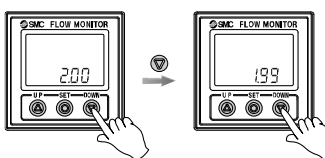

- Press the DOWN button once to decrease by one digit, or press and hold to continuously decrease.

- 3. Press the SET button to finish the setting. For models with switch outputs for both OUT1 and OUT2, [P\_2] or [n\_2] will be displayed, and for models with temperature sensor [tn] or [tp] will be displayed.
- For setting of hysteresis, perform the settings referring to [F 1] Setting of OUT1 and [F 2] Setting of OUT2.
- For more detailed settings, set each function in Function selection mode while referring to the operation manual.

## 7 Function Settings

### 7.1 Function selection mode

In measurement mode, press the SET button for 2 seconds or longer to display [F 0]. Select to display the function to be change [F□□]. Press and hold the SET button for 2 seconds or longer to return to measurement mode.

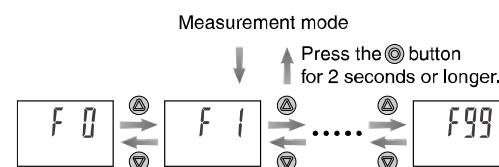

The function number is increased and decreased by the UP and DOWN buttons. Display the required function number and press the SET button.

### 7.2 Sub screen display

In measurement mode, the sub screen display can be temporarily changed by pressing the UP or DOWN buttons. After 30 seconds, it will automatically reset to the display selected in [F10]. Example shown is for the 4 L/min type.

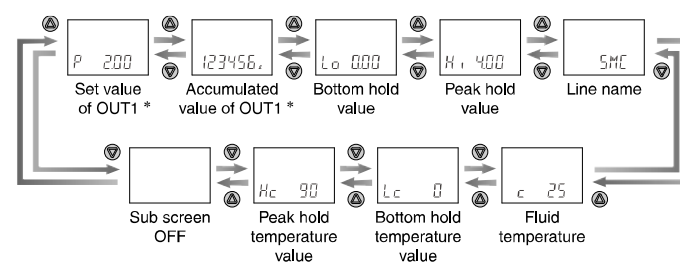

## 7 Function Settings (continued)

### 7.3 Default function settings

Item	Default setting
[F 0] [ rAn] Sensor selection range	[ 4] 4 L sensor
[F 1] [ oUt1] Output mode (OUT1)	[ HYS] Hysteresis mode
[ 1ot] Switch operation (OUT1)	[ 1_P] Normal output
[ P_1] Set value (OUT1)	50% of maximum rated flow
[ H_1] Hysteresis (OUT1)	5% of maximum rated flow
[ CoL] Display colour (OUT1)	[ SoG] ON: Green OFF: Red (OUT1)
[F 2] [ oUt2] Output mode (OUT2)	[ HYS] Hysteresis mode
[ 2ot] Switch operation (OUT2)	[ 2_P] Normal output
[ P_2] Set value (OUT2)	50% of maximum rated flow
[ H_2] Hysteresis (OUT2)	5% of maximum rated flow
[F 3] [ rES] Response time setting	[ 100] 1 second
[F10] [ SUB] Sub screen display setting	[ oU1] Set value of OUT1 displayed.
[F 20] [ iNP] Setting of External input	[REACUM] Accumulated flow external reset
[F 22] [ AnA] Setting of Analogue output	[ FLoW] Output of flow.
[ FrE] Free range	[ oFF] Free range: OFF
[F30] [ SAvE] Accumulated flow value storage	[ oFF] OFF (not held)
[F80] [ diSP] Power saving mode	[ oN] Normal display
[F81] [ Pin] Security code setting	[ oFF] OFF
[F82] [ LinE] Input of line name	[*****] No name
[F90] [ ALL] Setting of all functions	[ oFF] OFF
[F96] [ SEN iN] Input check (INPUT1 or INPUT2)	[ ] OFF
[F97] [ CoPY] Copy function	[ oFF] OFF
[F98] [ tESt] Output test mode	[ NoRMAL] OFF
[F99] [ iNi] Reset to the default settings	[ oFF] OFF

## 8 Other Settings

- Reset of accumulated flow function
- Peak / Bottom hold function
- Key-lock function

Refer to the operation manual on the SMC website (URL: <https://www.smcworld.com>) for setting these functions.

## 9 How to Order

Refer to the operation manual or catalogue on the SMC website (URL: <https://www.smcworld.com>) for How to order information.

## 10 Outline Dimensions (mm)

Refer to the operation manual or catalogue on the SMC website (URL: <https://www.smcworld.com>) for Outline Dimensions.

## 11 Troubleshooting

### 11.1 Error indication

Error	Error displayed	Description	Measures
OUT1 over current error	Er 1	A load current of 80 mA or more is flowing to the switch output (OUT1).	Turn the power off and remove the cause of the over current. Then turn the power on again.
OUT2 over current error	Er 2	A load current of 80 mA or more is flowing to the switch output (OUT2).	Turn the power off and remove the cause of the over current. Then turn the power on again.
Excessive instantaneous flow	HHH	The applied flow rate is above approx. 110% of maximum rated flow.	Reset applied flow to a level within the display range.
Sensor disconnection error	LLL	The remote sensor is not connected to the monitor, or the sensor output is below 0.6 V.	Connect the sensor or check the sensor output voltage.
Excessive accumulated flow	-999999- ↑ -999-	The accumulated flow range is exceeded. (the decimal point may flash depending on the flow range).	Reset the accumulated flow once. (Press the UP and DOWN button for 1 second or longer).
Temp. upper limit exceeded	cHHH	The fluid temperature is above 110 °C.	Reduce the fluid temperature.
Temp. lower limit exceeded	cLLL	The fluid temperature is below -10 °C.	Increase the fluid temperature.
Temp. sensor disconnection error		The temperature sensor output is not connected.	Connect the temperature sensor output line.
		The remote sensor does not have a temperature sensor.	Check that the temperature can be measured using the remote sensor.
Temp. sensor failure		If an error is displayed even if measures are taken to improve the "temperature lower limit exceeded" and "temperature sensor is not connected", the temperature sensor of the remote sensor may be damaged.	Contact SMC for repair.
System error	Er 0 Er 4 Er 6 Er 8	Displayed if an internal data error has occurred.	Turn the power off and turn it on again. If the failure cannot be solved, contact SMC for repair.

If the error cannot be reset after the above measures are taken, or errors other than the above are displayed, please contact SMC.

Refer to the operation manual on the SMC website (URL: <https://www.smcworld.com>) for more detailed information about troubleshooting.

## 12 Maintenance

### 12.1 General Maintenance

#### Caution

- Not following proper maintenance procedures could cause the product to malfunction and lead to equipment damage.
  - If handled improperly, compressed air can be dangerous.
  - Maintenance of pneumatic systems should be performed only by qualified personnel.
  - Before performing maintenance, turn off the power supply and be sure to cut off the supply pressure. Confirm that the air is released to atmosphere.
  - After installation and maintenance, apply operating pressure and power to the equipment and perform appropriate functional and leakage tests to make sure the equipment is installed correctly.
  - If any electrical connections are disturbed during maintenance, ensure they are reconnected correctly and safety checks are carried out as required to ensure continued compliance with applicable national regulations.
  - Do not make any modification to the product.
  - Do not disassemble the product, unless required by installation or maintenance instructions.
- **How to reset the product after a power cut or when the power has been unexpectedly removed**  
 The settings of the product are retained from before the power cut or de-energizing.  
 The output condition also recovers to that before the power cut or de-energizing, but may change depending on the operating environment. Therefore, check the safety of the whole system before operating the product.

## 13 Limitations of Use

### 8.1 Limited warranty and Disclaimer/Compliance Requirements

Refer to Handling Precautions for SMC Products.

## 14 Product disposal

This product should not be disposed of as municipal waste. Check your local regulations and guidelines to dispose of this product correctly, in order to reduce the impact on human health and the environment.

## 15 Contacts

Refer to [www.smcworld.com](https://www.smcworld.com) or [www.smc.eu](https://www.smc.eu) for your local distributor / importer.

# SMC Corporation

URL : <https://www.smcworld.com> (Global) <https://www.smc.eu> (Europe)  
 SMC Corporation, 1-5-5, Kyobashi, Chuo-ku, Tokyo 104-0031, JAPAN  
 Specifications are subject to change without prior notice from the manufacturer.  
 © SMC Corporation All Rights Reserved.  
 Template DKP50047-F-085O