



ORIGINAL INSTRUCTIONS

Instruction Manual

Bar Type Ionizer

Series IZS51

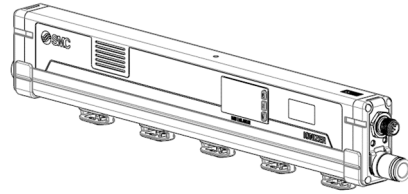

The intended use of this product is to neutralize electrostatically charged objects.

1 Safety Instructions

These safety instructions are intended to prevent hazardous situations and/or equipment damage. These instructions indicate the level of potential hazard with the labels of "Caution," "Warning" or "Danger."

They are all important notes for safety and must be followed in addition to International Standards (ISO/IEC)¹⁾, and other safety regulations.

¹⁾ ISO 4414: Pneumatic fluid power - General rules and safety requirements for systems and their components.

ISO 4413: Hydraulic fluid power — General rules and safety requirements for systems and their components.

IEC 60204-1: Safety of machinery - Electrical equipment of machines. Part 1: General requirements.

ISO 10218-1: Robots and robotic devices - Safety requirements for industrial robots - Part 1: Robots.

Refer to product catalogue, Operation Manual and Handling Precautions for SMC Products for additional information.

Keep this manual in a safe place for future reference.

	Danger	Danger indicates a hazard with a high level of risk which, if not avoided, will result in death or serious injury.
	Warning	Warning indicates a hazard with a medium level of risk which, if not avoided, could result in death or serious injury.
	Caution	Caution indicates a hazard with a low level of risk which, if not avoided, could result in minor or moderate injury.

Warning

- Always ensure compliance with relevant safety laws and standards. All work must be carried out in a safe manner by a qualified person in compliance with applicable national regulations.

1.1 Safety instructions

Warning

- This product is intended for use in general factory automation.** Consult SMC beforehand when using this product for other intentions.
- Use within the specified voltage and temperature range.** Operation with a voltage other than that specified can cause malfunction, damage to the product, electric shock or fire.
- Use clean compressed air as fluid.** Never use flammable or explosive gas as fluid. This may lead to fire or explosion. If fluid other than compressed air is used, consult SMC.
- The product is not designed to be explosion proof.** Never use in an atmosphere of potential dust explosion, flammable gas or explosive gas. It may cause fire.

Caution

- Clean specification is not available with this product.** This product has not suitable for a clean room environment. When using this product in a clean room environment, flush and confirm the product's purification level before use. A minute amount of particles are generated due to wearing of the emitters while the ionizer is operating.

Refer to the operation manual and catalogue on the SMC website (URL: <https://www.smcworld.com>) for further Safety Instructions.

2 Installation

2.1 Installation

Warning

- Do not install the product unless the safety instructions have been read and understood.

- Reserve enough space for maintenance, inspection and wiring. Take into consideration that the connectors need enough space to be easily attached / detached.

To avoid unreasonable stress applied to the connector mounting parts, bending of the cable should be more than the minimum bending radius. If the cable is bent in an acute angle or load is applied to the cable repeatedly, it may cause malfunction, wire damage or fire.

Minimum bending radius:

Power supply cable (for NPN/PNP type): IZS51-CP: 50 mm

Power supply cable (for IO-Link type): IZS51-CQ: 50 mm

Communication cable: IZS51-CE: 40 mm

Relay cable: IZS51-CF: 50 mm

Note: This is an allowable bend radius at 20°C. Bend radius should be larger at lower than 20°C.

- Mount on a flat surface.

Mounting on an uneven surface will apply excessive force to the housing and bracket, which may lead to damage or failure. Do not drop the product or subject it to a strong impact.

- Install the product so that the bar does not have excessive deflection.

For a bar length of 800 mm or more, support the bar at both ends and in the centre using brackets (IZS51-BM1 or IZS51-BM2). If the bar is held only at each end, the bar weight causes deflection, resulting in damage to the bar.

- Avoid installing in a place where noise (electromagnetic wave and surge) is generated.

It may cause malfunction, deterioration or damage to internal components. Take measures to prevent noise at its source and avoid power and signal lines from coming into close contact.

- Tighten screws to the specified torque.

If the screws are tightened in excess of the specified torque range, it may damage the mounting screws, mounting brackets, etc. If the tightening torque is insufficient, the mounting screws and brackets may become loose.

- Do not directly touch the emitters.

Do not directly touch the emitter with your finger. If the emitter sticks to your finger, or electrical shock makes an instantaneous rapid body motion to escape from the shock, your body may touch the equipment around you, causing injury. If emitter or cartridge is damaged by tools, etc., it may interfere with the specified function and performance, and may also cause operation failure and accident.

Caution: High Voltage

High voltage is applied to the emitters. Never touch the emitters. Inserting foreign matter into the cartridge or touching emitter may cause electric shock and instantaneous rapid body motion to escape from the shock. Your body may then impact the equipment around you, causing injury.

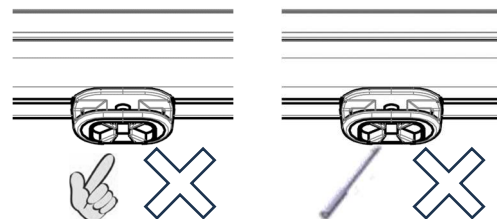

- Do not affix tape or labels to the product.

If the tape or label contains conductive adhesive or reflective paint, it is possible that due to the dielectric effect, charge could build up causing an electro-static discharge or electrical leakage.

- Be sure to disconnect the power supply and air supply to the product before starting the installation.

2 Installation (continued)

Caution

- Install the IZS51 series ionizer maintaining a distance from a wall, etc. as shown in the figure below.

When there is a wall or an object within the area shown in the figure, generated ions may not reach the workpiece effectively, resulting in deterioration of efficiency.

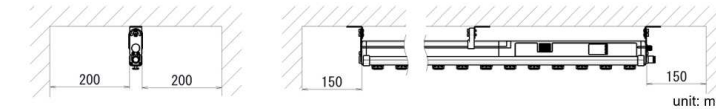

- Verify the performance of the product after installation.

The effect of the ionizer varies depending on the surrounding installation and operating conditions. Confirm the effect of static electricity elimination after installation.

- When installing ionizers which operate in DC mode (one polarity, positive or negative) with the IZS51 close together, they should be positioned at least 2 meters apart from each other.

When the IZS51 operating in AC mode is close to an ionizer operating in DC mode, separate the ionizers by at least 2 meters.

The offset voltage (ion balance) may not be adjusted by the built-in sensor due to the ions discharged from an ionizer which operates in DC mode.

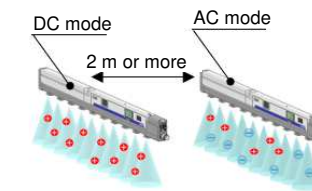

2.2 Environment

Warning

- Do not use in an environment where corrosive gases, chemicals, salt water or steam are present.
- Do not use in an explosive atmosphere.
- Do not expose to direct sunlight. Use a suitable protective cover.
- Do not install in a location subject to vibration or impact. Check the product specifications.
- Do not mount in a location exposed to radiant heat.
- Operate the product within the specified fluid and ambient temperature range.

Operating ambient temp. range: Ionizer 0 to 40°C, Remote controller 0 to 45°C, AC adapter 0 to 40°C. Avoid sudden temperature changes even within the specified temperature range, as it may cause condensation.

- Do not use this product in an enclosed space.

This product utilizes the corona discharge phenomenon. Do not use the product in an enclosed space as ozone and nitrogen oxides exist, even though in marginal quantities.

- Environments to avoid

Never use or store the product under the following conditions:

- Areas where the ambient temperature exceeds the operating temperature range.
- Areas Where ambient humidity exceeds the operating humidity range.
- Areas where abrupt temperature changes may cause condensation.
- Areas where corrosive gas, flammable gas or other volatile flammable substances are stored.
- Areas where the product may be exposed to conductive powder such as iron powder or dust, oil mist, salt, organic solvent, machining chips, particles or cutting oil (including water and any liquids), etc.
- Areas in the path of direct air flow, such as air conditioners.
- Enclosed or poorly ventilated areas.
- Locations that are exposed to direct sunlight or heat radiation.
- Areas where strong electromagnetic noise is generated, such as strong electrical and magnetic fields or supply voltage spikes.
- Areas where the product is exposed to static electricity discharge.
- Locations where strong high frequency is generated.
- Locations which are subject to potential lightning strikes. The ionizer, remote controller and AC adapter are not resistant to lightning surge.
- Areas where the product may be exposed to direct impact or vibration.
- Areas where the product may be subjected to forces or weight that could cause physical deformation.

2 Installation (continued)

2.3 Mounting and installation of the bracket

- 2 types of end bracket and intermediate bracket are available. When end bracket type 1 is used, use intermediate bracket 1. For end bracket 2, use intermediate bracket 2.

1) End bracket

For mounting, fix the end bracket at both ends of the bar using M4 screws, to the specified tightening torque: 0.51 to 0.55 N·m.

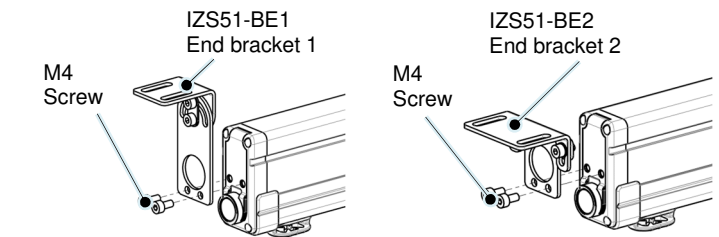

2) Intermediate bracket (for bar length of 800 mm or more)

Align the protrusion on the intermediate bracket with the groove of the ionizer and slide the bracket from the end or middle of the bar. Intermediate brackets should be mounted at the same intervals.

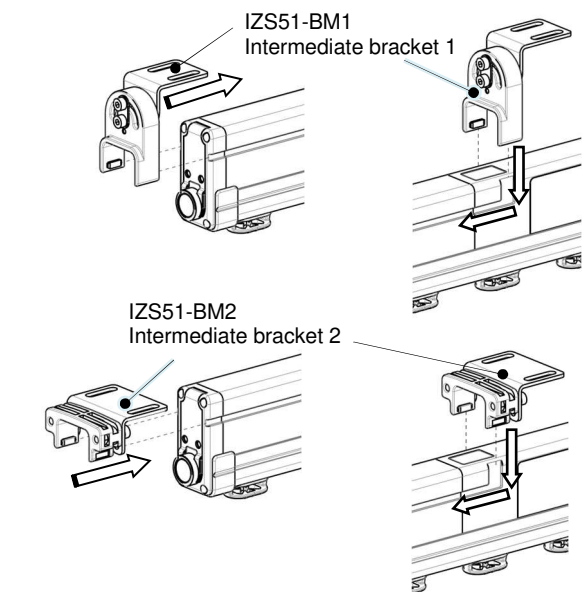

3) Installation of the ionizer

Mount the bracket to the specified position using M5 screws.

Refer to the operation manual for dimensional details.

The screws should be supplied by the user. The fixing part of the brackets thickness is 2 mm, recommended mounting screw is M5x8 mm.

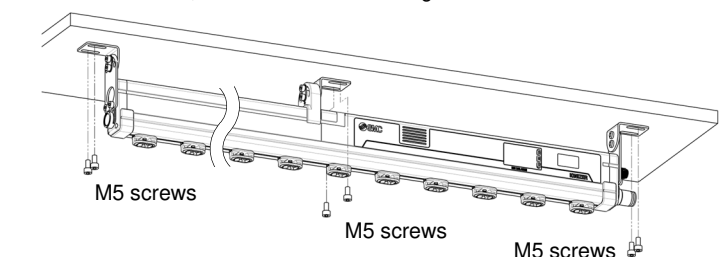

4) Mounting angle adjustment

Adjust the mounting angle of the ionizer for effective neutralization and fix the product using the M4 rotation set screw at each bracket.

End brackets (IZS51-BE1 and -BE2): 0.72 to 0.76 N·m.

Intermediate brackets (IZS51-BM1 and -BM2): 0.47 to 0.49 N·m.

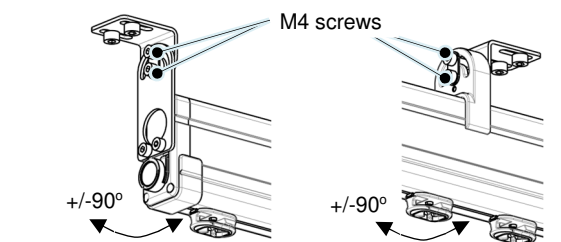

IZS51-BE1
End bracket 1

IZS51-BM1
Intermediate bracket

2 Installation (continued)

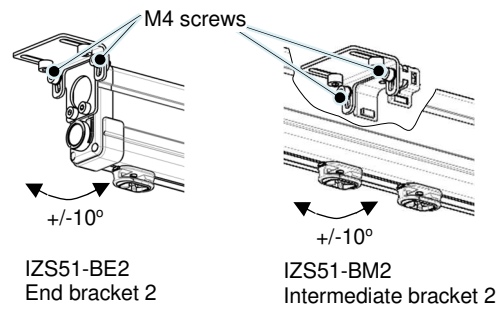

2.4 Piping

Caution

- Before piping make sure to clean up chips, cutting oil, dust etc.
- Flush the piping before connecting. Verify that all dust, moisture, oil, etc. are eliminated from the piping before connecting.
- **Do not use air containing mist and / or dust.**
Air containing mist and / or dust may cause deterioration of performance and reduce the maintenance cycle.
Install a dryer (IDF series), air filter (AF/AFF series), or mist separator (AFM/AM series) to obtain clean compressed air (air quality of Class 2.6.3 or higher according to ISO 8573-1: 2001 is recommended for operation).
- **Selection of piping port size**
Refer to the operation manual for the recommended piping port size and connect piping either to one side or both sides depending on the bar length or one-touch fittings.
For models with a valve unit, air is supplied from the piping port of the valve unit, and the opposite end of the ionizer is plugged.
For some ionizer bar lengths, the valve unit is installed at both ends of the bar. Supply air from both piping ports.
If a tube is used which is thicker than the recommended tube, neutralization performance will be deteriorated due to a shortage of air flow.

3 Wiring

3.1 Wiring

Warning

- Ensure that the power supply capacity meets the specification and that the voltage is within specification before wiring.
- To maintain product performance, the power supply should be UL Class 2 certified by National Electric Code (NEC) or evaluated as a limited power source according to UL60950.
- Wiring (including insertion and removal of the power supply connector) should never be carried out with the power supply ON. Otherwise, an electrical shock or accident may occur.
- Use the specified cables for connecting this product. Do not disassemble or retrofit them. This may cause product failure, electric shock or fire.
- Ensure the safety of wiring and surrounding conditions before supplying power.
- Malfunctions induced by noise may occur if the wire is installed in the same route as that of power or high-voltage cables. Wire the ionizer separately.
- Confirm that the wiring is correct before operation. Incorrect wiring will lead to a malfunction or breakage of the product.

3.2 Ground connection of F.G. cable

- Make sure to ground the F.G. cable with a resistance of 100 Ω maximum. The F.G. cable is used as a reference electric potential for de-ionization. If the ground terminal F.G. is not grounded, the ionizer will not be able to achieve the optimal offset voltage.
- When an ionizer is used in DC mode, make sure to ground the F.G. cable and DC(-) cable of the input power supply with a resistance of 100 Ω maximum. Without grounding the DC(-) cable, the ionizer and/or power supply may be damaged.

3 Wiring (continued)

3.3 Wiring connections (for NPN and PNP)

3.3.1 Power supply cable IZS51-CP**

Used for IZS51-**N (NPN type) and IZS51-**P (PNP type)

This cable supplies power to the product and connects input/output signals between the product and external devices. This cable also supplies power to external equipment used to control this product.
Connect the power supply cable M12 8-pin socket connector (A coded) to the ionizer. Pay attention to the key alignment when connecting. Connect the lead wires according to the wiring diagram. Unused wires should be cut short or insulated using insulation tape.

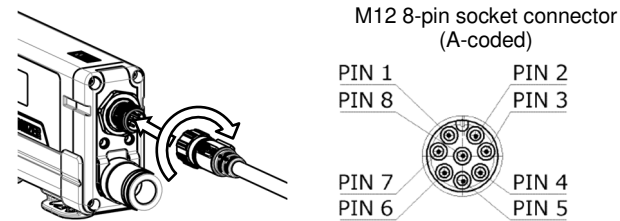

Pin No.	Wire colour	Signal	Signal direction	Description
1	Brown	DC(+)	IN	Power supply + for ionizer.
2	Pink	Ion generation stop signal	IN	Signal input to stop ion generation. NPN type: Ion generation is stopped by connecting to 0 VDC. PNP type: Ion generation is stopped by connecting 24 VDC.
3	Blue	DC(-)	IN	Power supply - for ionizer.
4	Grey	Air supply stop signal	IN	Signal input to turn ON/OFF air supply when ion generation or air supply stops or synchronization is OFF. NPN type: Connect to 0 VDC, stop air supply by closing valve. PNP type: Connect to 24 VDC, stop air supply by closing valve. [Only for models with valve unit].
5	Purple	Error signal	OUT1 (B contact)	Turns OFF in case of power supply failure, high voltage failure, CPU failure or output signal over current. (signal is ON for no problem).
6	Yellow	Maintenance detection signal	OUT2 (A contact)	Turns ON when emitter needs cleaning.
7	White	-	-	-
8	Shield	F.G.	-	Ground terminal (F.G.).

3 Wiring (continued)

3.4 Wiring diagram

3.4.1 IZS51-**N (NPN type)

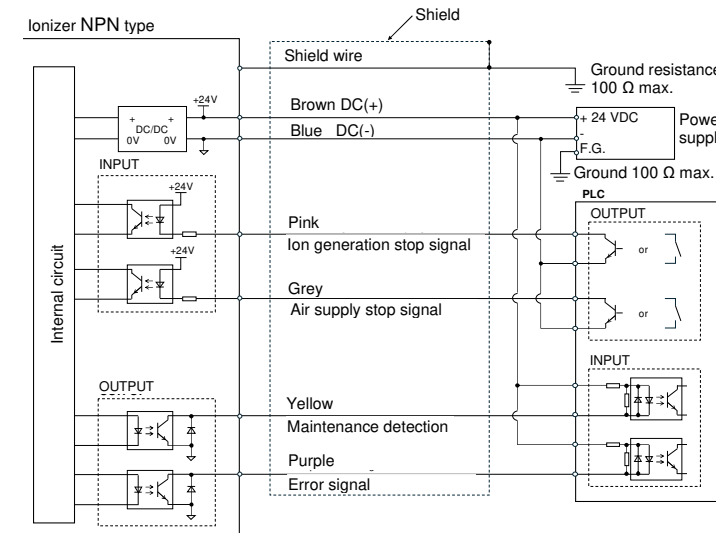

3.4.2 IZS51-**P (PNP type)

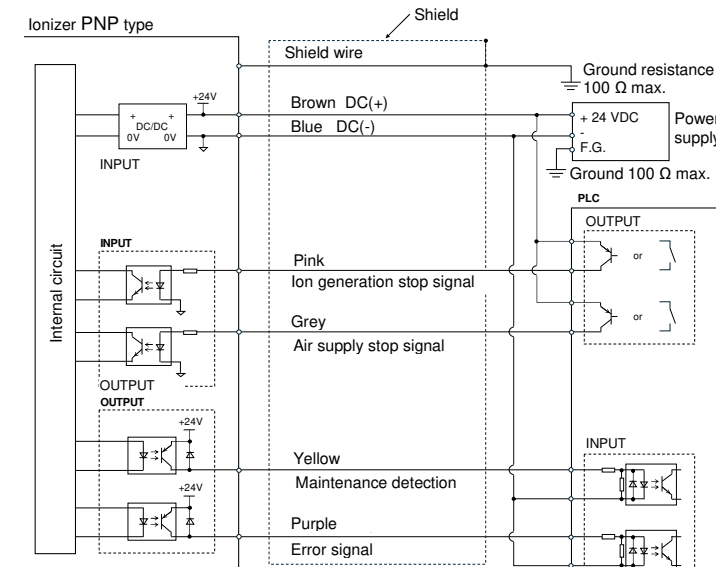

3.5 Wiring connections (for IO-Link)

3.5.1 Power supply cable IZS51-CQ**

Used for IZS51-**L (IO-Link type)

This cable supplies power to the product and connects input/output signals between the product and external devices.
Connect the power supply cable M12 socket 5-pin connector (B coded) to the T connector adapter. Pay attention to the key alignment when connecting the connector.

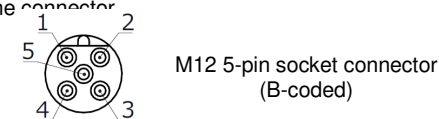

Pin No.	Wire colour	Signal	Description
1	Brown	DC(+)	Power supply + for ionizer.
2	-	-	-
3	Blue	DC(-)	Power supply + for ionizer.
4	-	-	-
5	Shield	F.G.	Ground terminal (F.G.).

3 Wiring (continued)

3.5.2 Communication cable IZS51-CE**

Used for IZS51-**L (IO-Link type)

A cable for IO-Link communication with the product.
Connect the communication cable M12 5-pin socket connector (B coded) to the T connector adapter.
Pay attention to the key alignment when connecting them together.

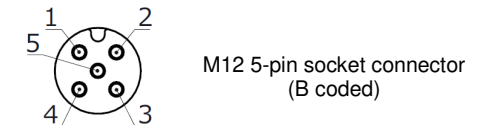

Pin No.	Signal	Description
1	L+	Power supply for IO-Link type.
2	-	-
3	L-	Power supply for IO-Link type.
4	C/Q	IO-Link communication data.
5	-	-

3.5.3 Relay cable IZS51-CF**

Used for IZS51-**L (IO-Link type)

A cable for IO-Link communication with the product.
Connect the relay cable M12 8-pin socket to the ionizer power supply connector and connect the relay cable M12 8-pin plug to the T connector adapter socket.
Pay attention to the key alignment when connecting them together.

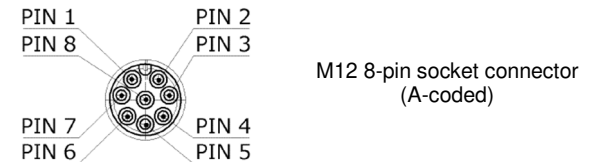

3.5.4 Connection arrangement for IZS51-**L (IO-Link type)

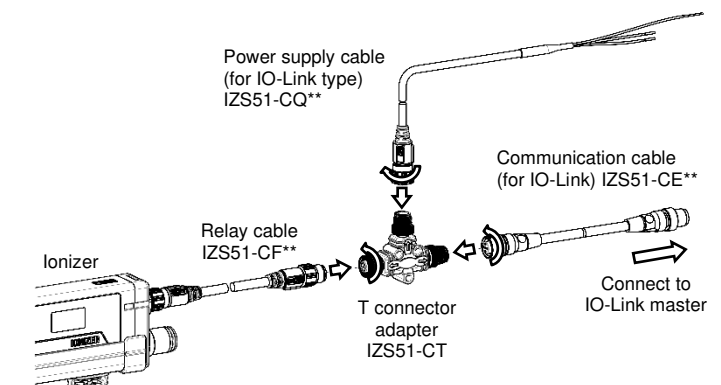

3.6 AC Adapter connection

- When an AC adapter is used (IZS51-CG*), perform F.G. wiring using the ground terminal (F.G.) of the AC cord. If the AC cord is plugged in, plug it into a grounded outlet with a resistance of less than 100Ω. Use an AC cord with ground terminal, if it is prepared by the user.
- The ground terminal (F.G.) is used as a reference electric potential for static neutralization. If the ground terminal is not grounded, the ionizer will not be able to achieve the optimal offset voltage (ion balance).
- When an AC adapter is used, the input/output signal cannot be used.

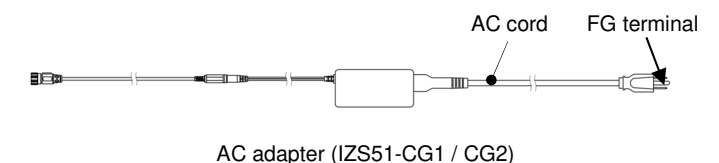

4 Specifications

4.1 Ionizer specifications

Ionizer model	IZS51-**N (NPN)	IZS51-**P (PNP)	IZS51-**L (IO-Link)
Ion generation method	Corona discharge method		
Method of applying voltage	AC, DC ^{Note 1)}		
Applied voltage ^{Note 2)}	+/-7,000 V		
Offset voltage ^{Note 3)}	Within +/-30 V		
Air purge	Fluid	Air (Clean and dry)	
	Operating pressure	0.5 MPa max.	
	Proof pressure	0.7 MPa	
	Connected tube O.D.	Metric size: f4, f6, f8, f10 Inch size: f1/16", f3/4", f5/16", f3/8"	
Power supply voltage	24 VDC +/-10%		
Current consumption	700 mA max.		
Input signal	Connect to	DC(-)	DC(+)
	Voltage range	5 VDC max.	19 VDC to supply voltage
	Current consumption	5 mA max.	5 mA max.
Output signal	Load current	100 mA max.	100 mA max.
	Residual voltage	1 V or less (at 100 mA load current)	1 V max. (at 100 mA load current)
	Max. supply voltage	26.4 VDC	-
IO-Link communication	Voltage range	-	18 to 30 VDC
	Current consumption	-	100mA max. (Refer to IO-Link specification).
Function	Auto balance, Maintenance detection, High voltage abnormality detection (ion generation stops when abnormality is detected), Ion generation stop input		
Effective static neutralizing distance	50 to 2000 mm		
Ambient and fluid temperature	0 to +40°C		
Ambient humidity	35 to 80% RH (no condensation)		
Material	Body: ABS, PBT, PC, Aluminium, SUS Emitter cartridge: PBT, SUS Emitter: Tungsten or Single crystal silicon		
Standards / Directives	CE (EMC directive, RoHS directive), UKCA		

Note 1) Apply cathode or anode to DC.

Note 2) Measured value with a high voltage probe (1000MΩ, 5pF).

Note 3) With air purge at a distance of 300 mm between the workpiece and ionizer.

4.2 Communication specifications

IO-Link type	Device
IO-Link version	V1.1
Configuration file format	IODD file
Communication speed	COM2 (38.4 kbps)
Minimum cycle time	8.0 ms
Process data length	Input Data: 3 bytes Output Data: 2 bytes
On-Request data	Compatible
Data storage	Compatible
Event	Compatible
Vender ID	131 (0x0083)
Device ID	666 (0x00029A)

5 Name and function of parts

5.1 IZS51 ionizer bar

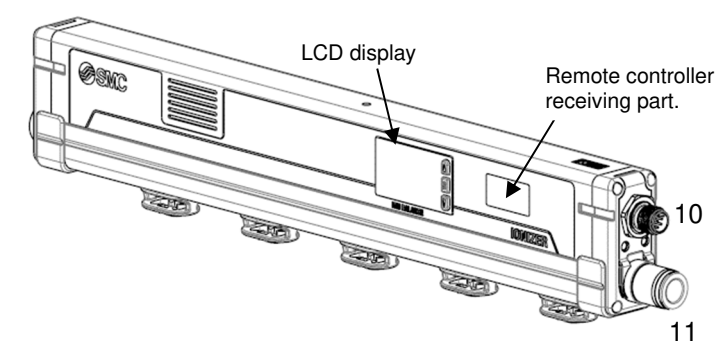

5.1.1 LCD display

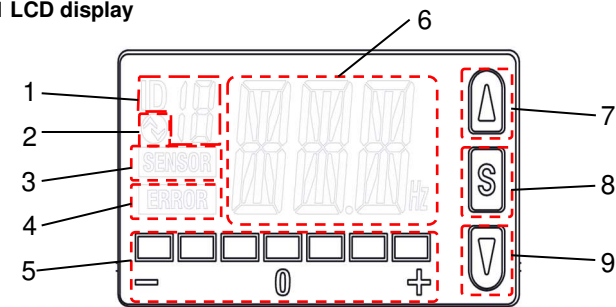

No.	Name	Indication	Type	Description
1	ID number display	ID*	LCD (White)	Displays the ID number (0 to 15) of the ionizer (NPN / PNP type only).
2	Communication status display		LCD (White)	Flashing when the IO Link communication is established. ON when the communication is not established or when there is a communication error (IO-Link type only).
3	Sensor display	SENSOR	LCD (White)	ON when balance control function is ON.
4	Error display	ERROR	LCD (White)	ON when any errors are detected.
5	Ion balance display	ION BALANCE	LCD (White)	Indicates the ion balance status by turning ON during operation. Flashing during offset voltage adjustment. ON when ion balance is maximum or minimum during offset voltage adjustment.
6	Frequency display	0.1 to 100 Hz DC+, DC-	LCD (Green, Red)	Displays frequency setting by turning ON Green during operation. Displays selected frequency by flashing Green during setting. Displays detected error details by flashing Red in case of abnormality.
7	▲ button	▲	Push button	Increases the set value.
8	S button	S	Push button	Change the mode and set a set value.
9	▼ button	▼	Push button	Decreases the set value.
10	M12 connector	-	Connector	Connector for power supply cable or relay cable.
11	One-touch fitting	-	Piping port	Piping port for air supply.

5 Name and function of parts (continued)

5.2 Remote controller (IZS51-RC)

Applicable models: IZS51-**N and IZS51-**P

- An infrared remote controller is used for these models. Communication cannot be established if there are obstacles between the remote controller and ionizer. When operating with a remote controller, install the ionizer with the receiving part exposed, and point the sending part of the remote controller at the receiving part of the ionizer. Maximum communication distance of the remote controller is 5 m.
- Before performing settings with a remote controller, make sure to set the same ID number as the number displayed on the LCD of the ionizer to be controlled, and enable the communication. The default ID number is 0.
- After completing settings with the remote controller, cancel the communication between the remote controller and the ionizer. It will not be possible to start operation of the ionizer until communication is cancelled. (Without any signal received from the remote controller for 30 seconds, communication will be canceled automatically).
- When communication is cancelled, the frequency display will turn ON (green) in the frequency setting.

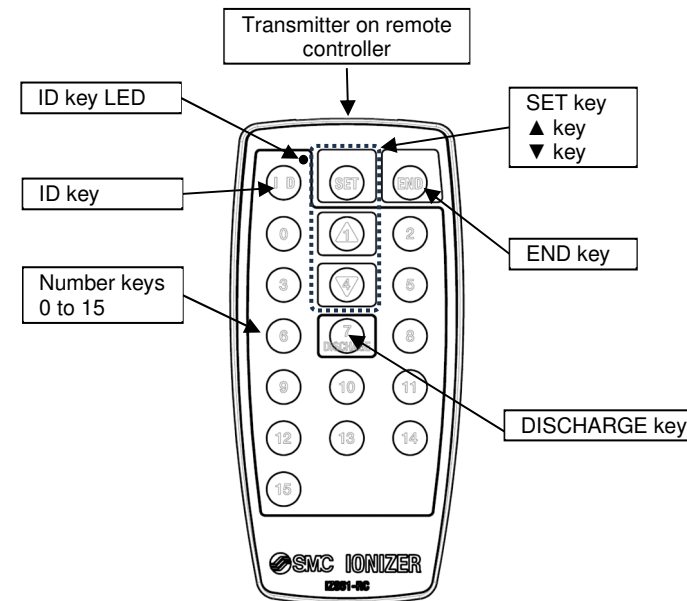

Name	Description
ID key	Input when enabling the ID number setting.
Number keys	Sets the ID number. Not operable when the ID key is OFF (LED of the ID key should be ON).
▲ key	Increase the set value.
SET key	Change the mode and set a set value.
▼ key	Decrease the set value.
END key	Used to clear the communication with the ionizer. Switches to normal operation.
DISCHARGE key	Used to stop ion generation from the Ionizer.

6 Settings

The following settings should be carried out before using the ionizer. Refer to the Operation manual (OM) available on the SMC website (<https://www.smcworld.com>).

- Frequency setting
- Offset voltage adjustment
- Balance control setting
- Maintenance detection level selection
- Ion generation stop / air supply stop synchronisation setting
- ID number setting
- Ion generation stop setting
- Output signal check mode
- Key lock setting

7 Operation flow chart

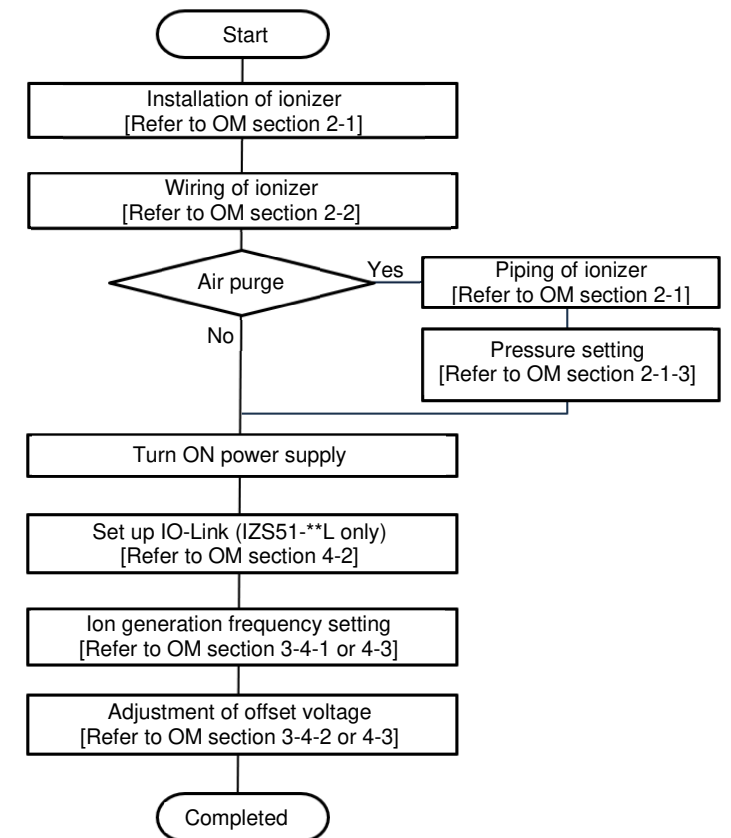

8 Alarm function

- IO-Link communication events and the LCD display are used for the notification of alarms and failures.
- Note that the ion generation may either continue or stop depending on the type of failure.

Alarm name	Output signal	Operation after alarm	LCD					How to return to normal operation	
			Display	Frequency	ERROR	ION BALANCE	SENSOR		ID number
Abnormality of the CPU	Error signal OFF (B contact)	Stop		Flash (Red)	ON (White)	OFF	OFF or ON (White)	ON (White)	Turn power off and on again.
Abnormality of power supply	Error signal OFF (B contact)	Stop		Flash (Red)	ON (White)	OFF	OFF or ON (White)	ON (White)	To be reset automatically.
Abnormality of high voltage	Error signal OFF (B contact)	Stop		Flash (Red)	ON (White)	OFF	OFF or ON (White)	ON (White)	- Ion generation stop signal OFF and ON again. - Turn the power off and on again.
Output signal over current	Maintenance detection signal OFF (A contact) - Error signal OFF (B contact)	Continue		Flash (Red)	ON (White)	OFF	OFF or ON (White)	ON (White)	To be reset automatically.
Maintenance warning	Maintenance detection signal ON (A contact)	Continue		ON (Green)	OFF	ON (White)	OFF or ON (White)	ON (White)	- Ion generation stop signal OFF and ON again. - Turn the power off and on again.

Note. During the time of any abnormality occurring the display will hold the status before the abnormality.

9 How to Order

Refer to the operation manual or catalogue for details of 'How to Order'.

10 Outline Dimensions

Refer to the operation manual or catalogue for outline dimensions.

11 Maintenance

11.1 General Maintenance

⚠ Caution

- Not following proper maintenance procedures could cause the product to malfunction and lead to equipment damage.
- If handled improperly, compressed air can be dangerous. Maintenance of pneumatic systems should be performed only by qualified personnel.
- Before performing maintenance, turn off the power supply and be sure to cut off the supply pressure. Confirm that the air is released to atmosphere.
- After installation and maintenance, apply operating pressure and power to the equipment and perform appropriate functional and leakage tests to make sure the equipment is installed correctly.
- Do not make any modification to the product.
- Do not disassemble the product, unless required by installation or maintenance instructions.

11.2 Maintenance and Inspection

⚠ Warning

• Perform maintenance regularly and clean the emitters.

Check regularly that the product is not operating with undetected failures. The maintenance must be carried out by an operator who has sufficient knowledge and experience.

If the product is used for an extended period with dust present on the emitters, the product performance will be reduced.

Maintenance detection function is installed to this product. When the emitter contamination is detected, clean the emitter.

In cases where the maintenance detection function is not used on this product is used, perform neutralizing performance test and set maintenance cycle for periodic cleaning.

Emitter contamination level is different depending on the installation environment.

If the performance is not recovered after cleaning, it is possible that emitters are worn. Replace the emitter cartridge (IZS51-N*).

• Be sure to remove the power supply and air supply to the lonizer before cleaning the emitters or replacing the emitter cartridge.

Never touch the emitter with the power supplied to the ionizer. Electric shock may cause injury.

If the emitter cartridge is removed while air is supplied, the emitter cartridge jumps out by compressed air. Replace the emitter cartridge after discharging the air supply.

If emitter cartridges are not securely mounted to the ionizer body, they may eject or release when air is supplied to the product.

Securely mount or remove the emitter cartridges referencing the instructions shown below.

Securely mount or remove the emitter cartridges by hand and do not use tools.

⚠ Caution: High Voltage

This product contains a high voltage generation circuit. When performing maintenance inspection, be sure to confirm that the power supply to the ionizer is turned off. Never disassemble or modify the product, as this can cause loss of product functionality, and there is also a risk of electric shock and earth leakage.

• Do not disassemble or modify the product.

This may lead to accidents such as electric shock, failure, fire or etc. If the product is disassembled and/or modified, the functions and performance in the specifications may not be achieved and the product will not be guaranteed.

• Do not operate the product with wet hands.

Never operate the product with wet hands. It may cause electric shock or other accidents.

⚠ Caution

- If the product is used for an extended period of time, contamination such as dust will stick to the emitters, reducing the static neutralization performance.
- The maintenance detection function is available. When the emitter contamination is detected, clean the emitter.
In cases where the maintenance detection function is not used, perform neutralizing performance test and set a maintenance cycle for periodic cleaning.

11 Maintenance (continued)

- The emitter contamination level is different depending on the installation environment and air supply pressure.
- If the maintenance signal is output upon completion of cleaning the emitter, it may not have been cleaned sufficiently or it may be worn or damaged. If the emitters are worn out or damaged, replace the emitter cartridge.
- If the emitter is worn out or damaged, the static electricity elimination performance will decrease.

11.3 Emitter cleaning procedure

- It is highly recommended that the emitter cleaning kit (IZS51-M3 or IZT43-M2) is used to clean the emitter needles.

• Cleaning procedure using the IZS51-M3

- Before cleaning the emitters, turn off the power supply and air supply.
- Place the cleaning kit (IZS51-M3) on the lonizer so that the brush touches the emitter and move it along the groove to clean it.

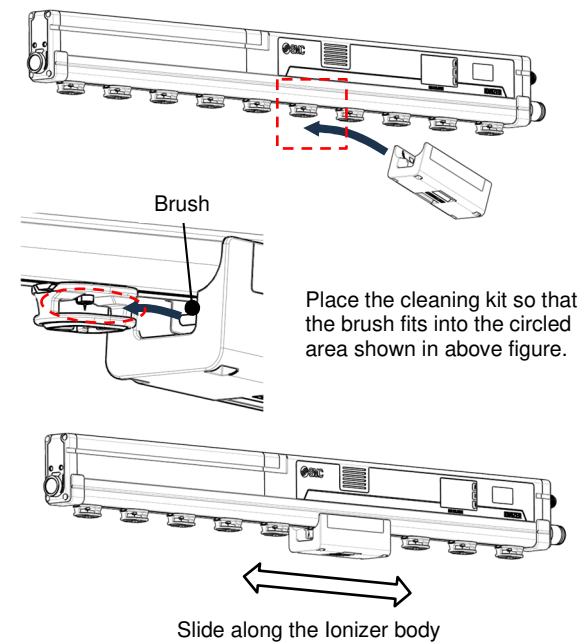

• Cleaning procedure using the IZT43-M2

- Before cleaning the emitters, turn off the power supply and air supply.
- The emitters may be cleaned with the emitter cartridges mounted to the lonizer body or with the cartridges removed from the lonizer body. Refer to the figure below for instructions on how to remove the cartridges.

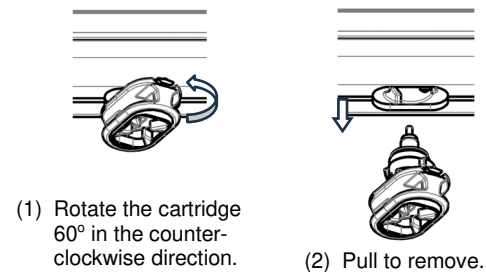

- The emitter cleaning kit (IZT43-M2) has felt at one end of the tool and rubber-bonded whetstone ^{Note} at the other end of the tool.

Note! Do not use a rubber bonded whetstone if the emitter material is silicon. The emitter tip may be accidentally broken off during cleaning.

11 Maintenance (continued)

Saturate the felt end of the emitter cleaning tool with alcohol and insert it into the back of the emitter cartridge. Turn the tool for several rotations to thoroughly remove dirt.

If it is not possible to thoroughly remove the dirt using the felt end of the cleaning tool, the rubber-bonded whetstone should be used in the same procedure as described for that of the felt end.

If you do not have a cleaning kit, an alcohol saturated cotton ball can be used for cleaning the electrodes. Use caution to prevent damage to the electrode needles.

The alcohol used should be reagent ethanol class 1 99.5 vol% or more.

- If the emitter cartridges have been removed for cleaning, remount them to the lonizer body according to the figure shown below. Make sure that the cartridges are securely mounted. If not, the cartridges may become dislodged when compressed air is supplied to the ionizer.

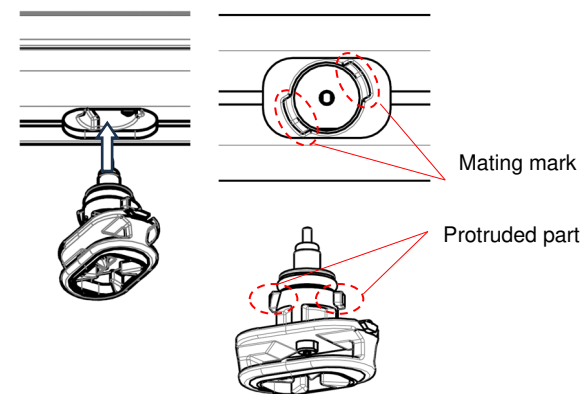

- Confirm that the static neutralization performance is maintained after cleaning and remounting of the cartridges are completed.

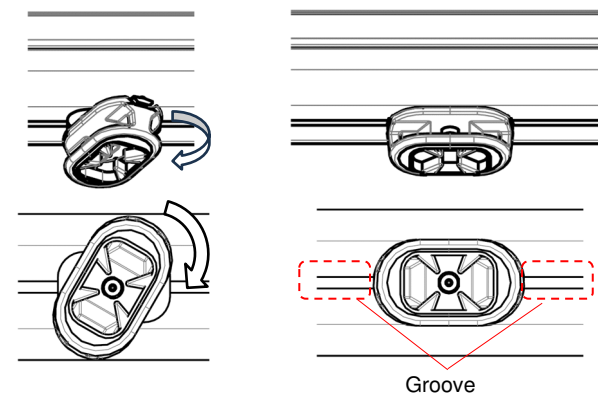

- Insert the emitter cartridge with aligning the protruded part on the cartridge and the mating mark on the lonizer body.
- Rotate the cartridge 60° in the clockwise direction until it is parallel to the groove on the bottom of the lonizer, then secure it in place.

12 Limitations of Use

12.1 Limited warranty and disclaimer/compliance requirements

Refer to Handling Precautions for SMC Products.

13 Product Disposal

This product shall not be disposed of as municipal waste. Check your local regulations and guidelines to dispose of this product correctly, in order to reduce the impact on human health and the environment.

14 Contacts

Refer to www.smcworld.com or www.smc.eu for your local distributor / importer.

SMC Corporation

URL : <https://www.smcworld.com> (Global) <https://www.smc.eu> (Europe)
SMC Corporation, 4-14-1, Sotokanda, Chiyoda-ku, Tokyo 101-0021, Japan
Specifications are subject to change without prior notice from the manufacturer.
© SMC Corporation All Rights Reserved.
Template DKP50047-F-085N