

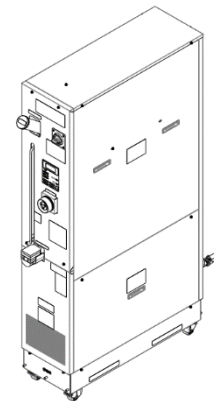

**Instruction Manual  
Thermo-Chiller  
INR-495-042**



The intended use of this product used a built-in pump to circulate a liquid such as water, adjusted to a constant temperature by the refrigeration circuit. This circulating liquid cools parts of customer's machine that generate heat start and stop the product and reset its alarms. Read this manual before using.

**1 Safety Instructions**

These safety instructions are intended to prevent hazardous situations and/or equipment damage. These instructions indicate the level of potential hazard with the labels of "Caution," "Warning" or "Danger." They are all important notes for safety and must be followed in addition to International Standards (ISO/IEC) (1), and other safety regulations. (1)ISO 4414: Pneumatic fluid power — General rules and safety requirements for systems and their components. ISO 4413: Hydraulic fluid power — General rules and safety requirements for systems and their components IEC 60204-1: Safety of machinery - Electrical equipment of machines.

**Part 1: General requirements**

ISO 10218-1: Robots and robotic devices - Safety requirements for industrial robots - Part 1: Robots

- Refer to product catalogue, Operation Manual and Handling Precautions for SMC Products for additional information.
- Keep this manual in a safe place for future reference.

<b>Danger</b>	Danger indicates a hazard with a high level of risk which, if not avoided, will result in death or serious injury.
<b>Warning</b>	Warning indicates a hazard with a medium level of risk which, if not avoided, could result in death or serious injury.
<b>Caution</b>	Caution indicates a hazard with a low level of risk which, if not avoided, could result in minor or moderate injury.

**Warning**

- **Always ensure compliance with relevant safety laws and standards.**
- All work must be carried out in a safe manner by a qualified person in compliance with applicable national regulations.

**2 Specifications**

**2.1 Product Specification**

INR-495-042

Model		INR-495-042	
Cooling Method		Single loop / Water-cooled refrigeration	
Temp. Setting Range / Temp. Stability	℃	-20 to 70 / ± 1.0 <sup>1)</sup>	
Temp. Control Method		PID control	
Cooling Capacity	kW	8.5 @ 20℃ <sup>2)</sup>	
Heating Capacity	kW	3.0 (Heater less) <sup>3)</sup>	
Refrigerant		R744 (CO <sub>2</sub> )	
Installation Environment	Ambient Temperature	℃	10 to 35
	Ambient Humidity	℃	30 to 70 (No condensation)
	Altitude	m	1000 or less
Facility Water	Temperature Range	℃	10 to 30
	Inlet Pressure Range	MPa	0.3 to 0.7
	Required Flow Rate <sup>4)</sup>	L/min	10 (Facility water Inlet temperature 10 to 20℃) 25 (Facility water Inlet temperature 30℃)
Circulating Fluid System	Fluid Type		Fluorinert™ FC-3283 <sup>5)</sup>
	Pump Capacity	MPa	0.5 (at 20L/min, 20℃) (Flow rate, supply pressure and pump output control can be selected.)
	Rated Flow Rate	L/min	20 <sup>6)</sup>
	Display Range of Flow Rate <sup>7)</sup>	L/min	5 to 40
	Display Range of Supply Pressure	MPa	0 to 1.5
Tank	Setting Range of Flow Rate	L/min	7 to 40 <sup>8)</sup>
	Setting Range of Supply Pressure	MPa	0.1 to 1.0 <sup>9)</sup>
	Setting Range of Pump Output	%	20 to 100
Power Supply	Capacity	L	Approx. 8 <sup>10)</sup>
	Free Space Capacity	L	Approx. 12 <sup>10)</sup>
	Rated voltage	V	3 Phase AC200/200 to 208 +/-10(%) (50/60Hz) <sup>11)</sup>
	Max. Operating Current	A	18
	Breaker Capacity	A	20 (Sensitivity of leak current: 30mA)
Circulating Fluid Wetted Materials			Stainless steel, Copper brazing (Heat exchanger), Silicone, Fluoropolymer, PPS
Facility Water Wetted Materials			Stainless steel, EPDM, Copper brazing (Heat exchanger), Silicone, Bronze, NBR, PPS
Operation Display Panel			LCD English indication
Communication function			Contact Input / Output, Analog communication (D-sub 25pin) Serial communication (RS-485) connector (D-sub 9pin)
Height Difference Between the Product and the External Equipment	m		10 or less
Accessory <sup>12)</sup>			Operation manual (Japanese: 1pc, English: 1pc) 2pcs, Anti-quake bracket (2pcs.) (M8 nut 6pcs.)
Weight	kg		185 (Dry condition)
Body Colour			White (SMC standard)

Notes:

- \*1: Conditions: Circulating fluid flow rate =20L/min, with short bypass tube between supply port and return port. Ambient temp. =25℃, Installation environment, Conditions of facility water, power voltage, etc. are within the specification limit.
- \*2: Conditions: Circulating fluid flow rate =20L/min, facility water temp. =25℃, facility water flow rate =17.5L/min. (The value of the cooling capacity when the product and heat load are connected directly with the shortest distance. The radiation from the piping between the chiller and your equipment have to be considered into total heat load.)
- \*3: Conditions: Circulating fluid flow rate =20L/min, supply pressure =0.5MPa, facility water temp. =25℃, facility water flow rate =17.5L/min. Hot gas of the refrigerating circuit is used as heat source. (The value of the heating capacity with short bypass tube between inlet and outlet. The heat radiation from the piping between the chiller and your equipment, it may not reach the set temperature. If it does not reach the set temperature, please increase the circulating supply pressure.)
- \*4: Required flow rate to maintain cooling capacity during cooling and not occur any issue. Please adjust the facility water flow rate according to the facility water inlet temperature.
- \*5: Fluorinert TM is a trademark of U.S. 3M.
- \*6: Required flow rate to maintain cooling capacity and temperature stability. When used below the rated flow, use the individually sold "by-pass piping set".
- \*7: When using accessory "by-pass piping set" flow becomes total of flow on customer side and flow on by-pass.
- \*8: Depending on the pressure drop of the piping, the set value can not be controlled.
- \*9: The volume is optimal range on tank.
- \*10: The volume of the free space capacity that can accommodate the liquid volume in customer system.
- \*11: The electric power with harmonic distortion may make the product false operation. Do not use power from inverter. +/-10% is the tolerance for voltage fluctuation and does not guarantee the rated capacity.

**2 Specifications (continue)**

**2.2 Production Serial Number Code**

The production serial number code printed on the label indicates the month and year of production as per the following table:

Year	2023	2024	2025	...	2028	2029	2030	...
	<b>Month</b>	B	C	D	...	G	H	I
<b>Jan</b>	o	Bo	Co	Do	...	Go	Ho	Io
<b>Feb</b>	P	BP	CP	DP	...	GP	HP	IP
<b>Mar</b>	Q	BQ	CQ	DQ	...	GQ	HQ	IQ
<b>Apr</b>	R	BR	CR	DR	...	GR	HR	IR
<b>May</b>	S	BS	CS	DS	...	GS	HS	IS
<b>Jun</b>	T	BT	CT	DT	...	GT	HT	IT
<b>Jul</b>	U	BU	CU	DU	...	GU	HU	IU
<b>Aug</b>	V	BV	CV	DV	...	GV	HV	IV
<b>Sep</b>	W	BW	CW	DW	...	GW	HW	IW
<b>Oct</b>	X	BX	CX	DX	...	GX	HX	IX
<b>Nov</b>	y	By	Cy	Dy	...	Gy	Hy	Iy
<b>Dec</b>	Z	BZ	CZ	DZ	...	GZ	HZ	IZ

**3 Transportation, Transfer and Moving**

**Caution**

- Do not set this system on its side during transportation. Oil in the compressor drains into the refrigerant pipe, which causes lubricant shortages, leading to damage to the compressor.
- Drain the remaining fluid out of the pipe as much as possible. The remaining fluid may spill if disregarded.
- Exercise caution not to damage the panel and piping with the forklift when transporting the system.

**3.1 Transporting with a Forklift**

**Warning**

- This product is heavy and requires a forklift to safely move it.
- For transporting with the forklift, be sure to insert the fork into a designed position. Always insert the forks all the way through. Be careful not to hit the casters and adjustable feet.
- Forklift insertion positions are on either left or right side of this system. Do not insert the from the front or the rear.
- Do not set this system on its side for transportation. Potential damage to this system carrying danger of personnel injury if disregarded.

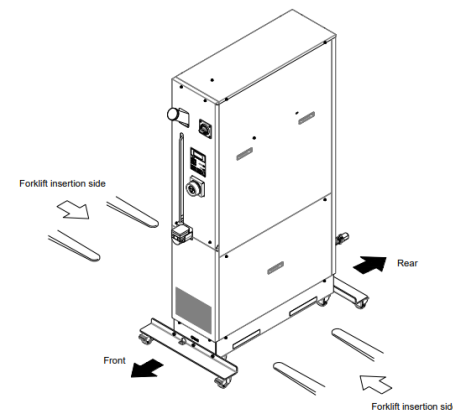

**3.2 Transporting with Caster**

**Warning**

This system is heavy, which requires assistance for this work. Exercise caution and look out for sloped surfaces such as ramps, etc.

**Caution**

Do not grab piping on the back of this system or panel handles when transporting with the casters. Potential damage to piping and panels may occur if disregarded.

**4 Installation**

**4.1 Installation**

**Warning**

- Product installation should be kept from areas with the potential of flammable gas leak. Ignition may occur if leaked gas is collected around the product.
- This product is NOT designed for outside use. Potential electric shock, fire and product damage may occur if exposed to rain, water and dust.

**4 Installation (continued)**

**Caution**

This product is to be installed on a level floor that can withstand the weight of this product. Potential water leak and personal injury due to system tipping over may occur if disregarded.

**4.2 Environment**

**Warning**

- Clean room specifications are not applied to this unit. The pump and ventilating fan installed in this unit generate particles.
- Do not use in an environment where dust, powder, corrosive gases, flammable gases, chemicals, oil, salt water or steam are present.
- Do not use in an explosive atmosphere.
- Do not expose to direct sunlight. Use a suitable protective cover.
- Do not install in a location subject to vibration or impact in excess of the product's specifications.
- Do not install in an environment that is subject to abrupt changes in temperature.
- Do not install in an environment that is subject to intense electromagnetic noise (intense electric field, intense magnetic field or surges) or strong high frequencies.
- Do not install in an environment that is subject to static electricity, or condition that discharges static electricity to the system.
- Do not install where the altitude is 1000m or higher.
- Do not mount in a location exposed to radiant heat that would result in temperatures in excess of the product's specifications.
- Ambient temperature of the environment must be 10 to 35 °C in operation and 0 to 45 °C in storage.
- Humidity of the environment must be 30 to 70% in operation and 15 to 85% in storage.
- Do not install in conditions that apply an external force or weight causing system deformation.
- Do not install if there is no adequate space for maintenance in the installation site.
- Location that is inclined.

**4.3 Installation**

**Warning**

- The Installer / End User is responsible for carrying out a noise risk assessment on the equipment after installation and taking appropriate measures as required.

**Caution**

- When installing this product, it is recommended to attach anti-quake bracket.
- Preparation of anchor bolts suitable for floor material is your responsibility. M12-anchor bolts (4 pcs.) are required.

**4.3.1 Procedure to install anti-quake bracket**

- Transfer system to the installation site.
- Lock the brakes on casters (2pcs. On the front).
- Using a 13-mm open end wrench, attach the anti-seismic brackets to the front and back.

**Caution**

- Drain pan port is assigned to the bottom on the back of the system. Exercise caution not to damage the drain pan port when attaching the seismic bracket.

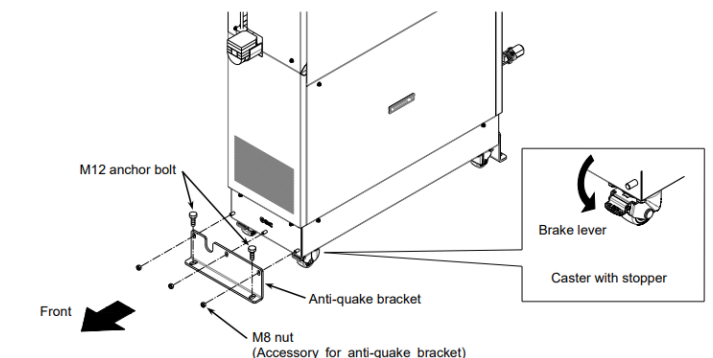

**4 Installation (continued)**

**4.4 Wiring**



- Only designated personnel are allowed to install wiring.
- Be sure to turn OFF the power prior to wiring to assure safety. Do not do any wiring when the system is energized.
- The system wiring requires not only a thorough connection with the designated cable but also securing to prevent loose connection. Poor connection and securing may cause electric shock, heat spots, fire or communication errors.
- Be sure to supply the power to this system according to specifications.
- Supply pure AC power. Potential malfunction may occur if a rectified AC with voltage rise (dv/dt) at zero crossing exceeds 40V /200μ sec.
- Always establish a connection to a ground for safety.
- Be sure that no ground connection is made to a water pipe, gas pipe and lighting rod.

**4.4.1 Wiring Installation**

Item		Cable Specifications	
Power cable	Size (recommended)	10AWG x4-conductor	
	Crimp Contact (recommended)	Breaker	R5. 5-5
		Earth bar	R5. 5-8
	Torque (recommended)	Breaker	2.5 N•m
Earth bar		12.5 N•m	
Main breaker		20A	

**4.4.2 Procedures for wiring installation**

1. Turn OFF the power breaker on the customer side (primary side), and then use the assigned procedures to perform lockout/tagout.
  - Connection of the power cable with this system must be established first. Do not connect the cable with the factory side at this point.
2. Turn OFF the main breaker of this system.
3. Undo the screws (4 pcs.) to remove the front panel.
4. Undo the screws (2 pcs.) or press claw to remove the breaker cover.
  - Make sure the breaker is at the 'Off' position.
  - Otherwise, the removal of the front panel is not possible.

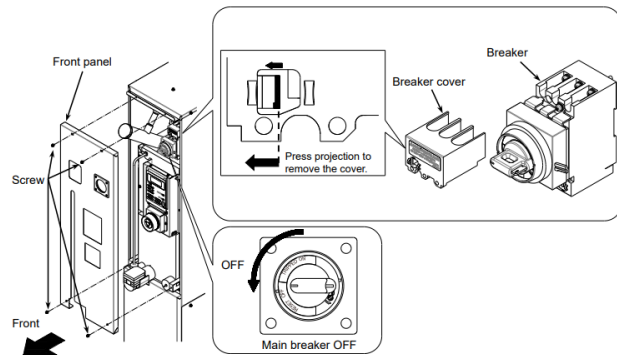

5. Loosen the cap at the power cable access (strain relief) and insert the power cable.
6. Connect the power cables to the breaker terminal, correct phase rotation is required.
7. Connect the ground terminal (M8) of the power cable to the earth bar. Use a 13-mm open end wrench. Recommended torque: 12.5 N•m.

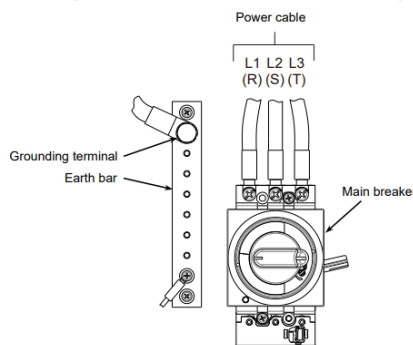

**4 Installation (continued)**

8. Attach the breaker cover to the breaker.
9. Attach front panel.
10. Connect the power cable to the power breaker on the customer/primary side.
11. Connect the communication cables with P1 and P2.

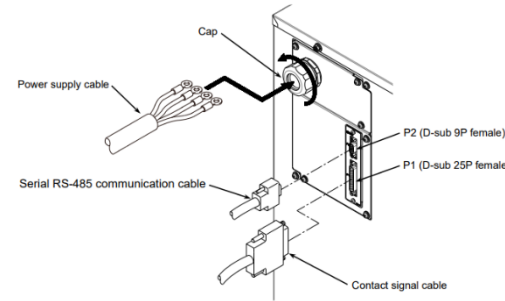

**4.5 Piping**



- Before connecting piping make sure to clean up chips, cutting oil, moisture, dust, and other particles. Apply air blow to the parts before using. The presence of particles, oil or moisture in the circulating fluid circuit causes insufficient cooling, system failure attributed to moisture freeze when entering the system or foaming of the circulating fluid in the tank.
- When installing piping or fittings, ensure sealant material does not enter inside the port. When using seal tape, leave 1 thread exposed on the end of the pipe/fitting.
- Tighten fittings to the specified tightening torque.
- Consider the suitability for the operating pressure and temperature of the circulating fluid and facility water, to minimise risk of pipes bursting during operation.
- Do not use corrosive materials such as aluminium and iron for fluid contact parts, like piping, as this may lead to clogging or leakage in the circulating fluid and facility water circuits, refrigerant leakage and other problems. Provide protection against corrosion when using this product.

- Always insulate external circulating piping, as this may affect cooling performance.
- When using fluorinated liquid as the circulating fluid, do not use pipe tape as leakage may occur. We recommend that you use the following sealant: SMC Part No. HRZ-S0003 (Silicone sealant)
- The total capacity of circulating fluid required by external piping should remain under the capacity of the tank.
- Be sure to choose a circulating fluid pipe capable of letting the fluid flow at the rated flow rate or better. See "Pump performance" defined in the operation manual, appendix 8.1.1 "System specification" for the flow rate rating.
- Have a drip pan available in case of a fluid leak.
- Do not return the circulating fluid to the unit by installing a pump in the user system.
- Make sure of the locations of ports for the circulating fluid supply, return, facility water inlet, outlet and their corresponding connections are correct.
- Do not give an impact when the piping connector section is fixed or tightened. It may damage the piping or cause leakage.
- The flow rate of the facility water is automatically adjusted depending on using conditions. The facility water outlet temperature can be up to 60°C.

**4.5.1 Pipe Diameter**

Pipe	Diameter	Recommended torque
Facility water inlet	Rc1/2	28 to 30 N • m
Facility water outlet	Rc1/2	28 to 30 N • m
Circulating fluid supply	Rc3/4	28 to 30 N • m
Circulating fluid return	Rc3/4	28 to 30 N • m
Tank drain port	Rc3/8 (with valve)	Piping not necessary
Drain pan port	Rc3/8	Piping not necessary

**4 Installation (continued)**

**4.5.2 Procedure for piping installation**

Secure the pipe coupling section with a pipe wrench and provide proper tightening to the pipe.

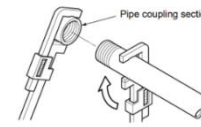

**4.5.3 Supply of circulating fluid**

- Remove the circulating fluid fill cap and fill the circulating fluid until it reaches its specified level.
- The circulating fluid specified level is a ranged between "HIGH" and "LOW".

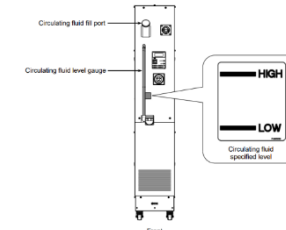

- Be sure to tighten the cap after fluid supply to avoid evaporation loss.
- If the circulating fluid is supplied over the specified level, follow the procedure provided in the operation manual section 7.3.1 "Draining of circulating fluid out of tank" to drain excess fluid until it reaches the specified level.

Note: Level between "HIGH" and "LOW" represents liquid in normal running conditions. The fluid level will start to drop, so additional fluid must be added until it is at the specified level.

**4.5.4 Facility Water Flow rate Setting**

Please adjust the facility water flow rate to the flow rate shown in the figure below by using the valve at the facility water inlet according to the facility water inlet temperature. Please gradually open the valve from the fully closed state and adjust the facility water flow rate. Also, do not let the facility water flow rate more than 40 L/min. It may cause the flow sensor to break. This flow rate is the minimum required flow rate.

Low facility water flow rate may cause the followings: -

- Low facility water flow rate alarm
- Decreased cooling capacity
- Failure of this product
- The outlet temperature of the facility water may reach 60°C or higher, which is dangerous

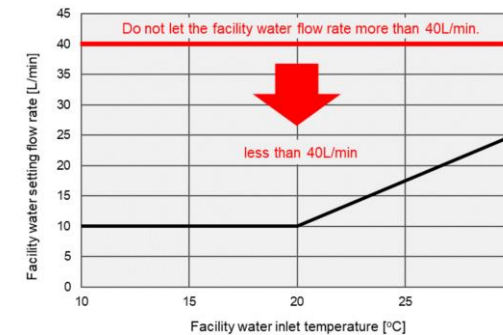

**5 Start, Stop and Menu Settings**

**5.1 Operation Display Panel**

- The name of parts used in this manual are as follows:

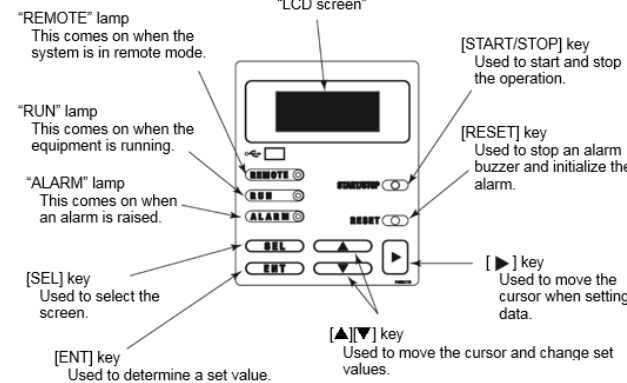

**5 Start, Stop and Temperature Settings (continued)**

**5.1 Power On**

- Turn on the breaker handle. The model and revision number of the system should be visible on the LCD display.
- This screen remains ON for approx. 5 seconds and is automatically switched to "Status screen 1" in approx. 20 seconds.
- The "Alarm Display screen" is displayed if error occurs in this system.

**5.2 System Startup and Shutdown**

System startup:

- Press the [START/STOP] key on the operation display panel.
- The [RUN] lamp on the operation display panel comes on, and the "System Information screen" is flashing. The screen then changes to the "Status screen 1", which initiates system operation.

System shutdown:

- Press the [START/STOP] key on the operation display panel.
- The "System Information screen" is flashing on the LCD screen, and the [RUN] lamp comes on. The compressor comes to a halt approx. 20 seconds after circulating pump stop for protection of the compressor. The screen is returned to the "Setting screen 1", which prompts the [RUN] lamp to go out.

**5.3 Different Modes and LED Screen**

There are many screens and mode that they system has. Using keys on the display panel, you can change the mode and information displayed. The LED screen can display up to four lines of text, in the following format. Please refer to the operation manual section 5.3 "Operation Screen" for the full flow chart and details of the screens.

**Status Screens**

Cycle through screens 1 to 4 by pushing the [▼] and [▲] keys.

Status Screen 2		
No.	Item	Description
1	TEMP PV	Discharge temperature of the circulating fluid
2	TEMP SP	Set circulating fluid temperature
3	<<TEMP READY>>	Displays the BAND/READY [Displayed when set value conditions are satisfied]*1
4	TEMP BAND	Set value of BAND range*1

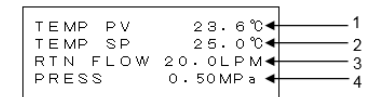

Status Screen 1		
No.	Item	Description
1	TEMP PV	Discharge temperature of the circulating fluid
2	TEMP SP	Set value of circulating fluid discharge temperature
3	RTN FLOW	Return flow rate of the circulating fluid
4	PRESS	Discharge pressure of the circulating fluid

\*1 - See in operation manual Chapter 8 "Appendix 8.5 BAND/READY".

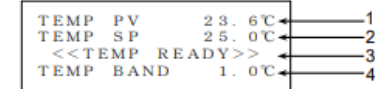

Status Screen 3		
No.	Item	Description
1	F.W. TEMP	Facility water inlet temperature
2	F.W. FLOW	Facility water flow rate
3	IN	Facility water inlet pressure
4	OUT	Facility water outlet pressure

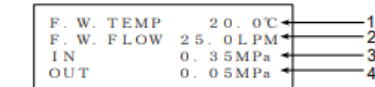

Status Screen 4		
No.	Item	Description
1	OFFSET	The current offset mode*1
2	OFFSET	Set offset

\*1 - See in operation manual Chapter 8 "Appendix 8.4 Offset Function".



### 5 Start, Stop and Menu Settings (continued)

#### 5.3.1 Alarm Display Screen

In case of an alarm, the screen will switch to the alarm display screen. It will display the alarm code and message.

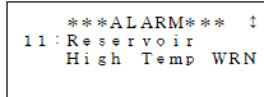

#### 5.3.2 Menu Screen

Press [SEL] key when on a status screen to change it to the menu screen. Press the [▼] and [▲] keys to select the item. Press the [ENT] key to switch to the selected screen. Press [SEL] to return to the status screens.

No.	Item	Descriptions
1	SETTING	Switches to the "Setting screen" with the press of the [ENT] key.
2	REMOTE MODE	Switches to the "Mode Selection screen" with the press of the [ENT] key.
3	MAINTENANCE	Switches to the "Initial Setting screen 1" with the press of the [ENT] key.

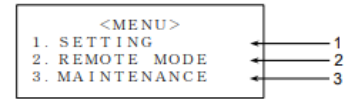

#### 5.3.3 Setting Screen

Press the [▼] and [▲] keys to select the item. Press the [ENT] key to switch to the selected screen. Press [SEL] to return to the menu screen.

No.	Item	Descriptions
1	CONTROL SET	Switches to the "Control Setting screen 1" with the press of the [ENT] key.
2	ALARM SET	Switches to the "Alarm Setting 1" with the press of the [ENT] key.
3	INITIAL SET	Switches to the "Initial Setting 1" with the press of the [ENT] key.



#### 5.3.4 Control setting features:

[▲] or [▼] key is used for selecting "Item." And pressing [ENT] key enabling changing the set point. Use the [▲] or [▼] key to change the set point value. Press [SEL] to return to the setting screen.

No.	Item	Descriptions	Setting Range	Factory Default
1	TEMP SP	Allows the sett of circulating fluid discharge temperature.	-20.0 to 70.0 °C	20.0 °C
2	OFFSET	Allows the setting of OFFSET value "1".	-20.0 to 20.0 °C	0.0 °C
3	PUMP SP	Allows the setting of circulating fluid flow rate. (PUMP IV set to FLOW)	7.0 to 40.0 LPM	20.0 LPM
		Allows the setting of circulating fluid discharge pressure. (When PUMP IV on "Initial Setting screen 3" is set to PRESS. Unit on the display will be switched to MPa.)	0.10 to 1.00MPa	0.10MPa

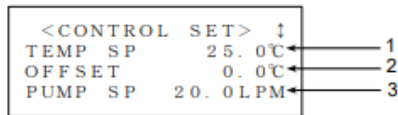

### 5 Start, Stop and Menu Settings (continued)

No.	Item	Descriptions	Setting Range	Factory Default
1	TEMP SP	Allows the sett of circulating fluid discharge temperature.	-20.0 to 70.0 °C	20.0 °C
2	OFFSET	Allows the setting of OFFSET value "1".	-20.0 to 20.0 °C	0.0 °C
3	PUMP SP	Switched to the "Control Setting screen 2-2". ("Control Setting screen 2-1" is displayed only if PUMP IV on "Initial Setting screen 3" is set to FREQ.)	--	--

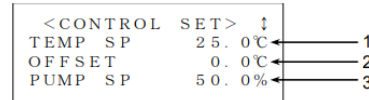

No.	Item	Descriptions	Setting Range	Factory Default
1	FLOW	Return flow rate of circulating fluid.	--	--
2	PRESS	Discharge pressure of circulating fluid.	--	--
3	FREQ	Switched to the "Control Setting screen 2-2". ("Control Setting screen 2-1" is displayed only if PUMP IV on "Initial Setting screen 3" is set to FREQ.)	20.0 to 100%	20.0%

\*1 - In the case of using Offset Function, select any one of MODE 1 to 3 on No.3 of "Initial Setting screen 1". See in operation manual Chapter 8 "Appendix 8.4 Offset Function".

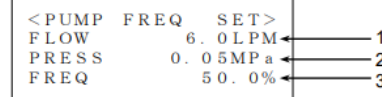

#### 5.3.5 Alarm setting features:

[▲] or [▼] key is used for selecting "Item" and move to other Alarm Setting screens. And pressing the [ENT] key enabling to change the set value. Press [SEL] to return to the setting screen.

- Alarm is raised when circulating fluid temperature exceeds or falls below the set value.

No.	Item	Descriptions	Setting Range	Factory Default
1	HI TEMP	Allows the setting of temperature to generate "11: Reservoir High Temp. WRN". Alarm is raised when circulating fluid	-20.0 to 75.0 °C	75.0 °C
2	LO TEMP	Allows the setting of temperature to generate "32: Reservoir Low Temp. WRN". Alarm is raised when circulating fluid temperature falls below the set value.	-25.0 to 75.0 °C	-25.0 °C

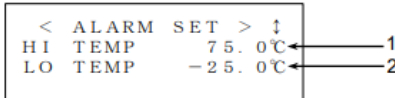

- Alarm is raised when flow rate falls below set value. Can be turned on/off.

No.	Item	Descriptions	Setting Range	Factory Default
1	LO FLOW WRN	Allows the setting of "13: Discharge Low Flow WRN" (valid: ON/invalid: OFF). Alarm is not raised if invalid: OFF is selected.	OFF, ON	ON
2	LO FLOW WRN	Allows the setting of flow rate to generate "13: Discharge Low Flow WRN". Alarm is raised when circulating	6.0 to 40.LPM	6.0LPM

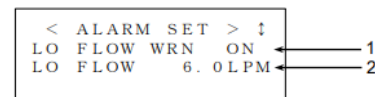

### 5 Start, Stop and Menu Settings (continued)

#### 5.3.6 Initial setting features:

See operation manual section 5.3.14 "Initial Setting screen" for full details.

[▲] or [▼] key is used for selecting "Item" and move to other Initial Setting screens. And pressing the [ENT] key enabling to select the setting. Press [SEL] to return to the setting screen.

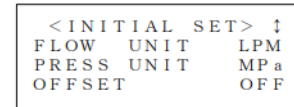

- Allows selection of the units for the flow rate and pressure.
- Allows selection of the offset mode.
- Options to store TEMP SP and FLOW SP values with serial communications. Also, setting for the device address for serial communication and selection of system conditions when an error occurs.

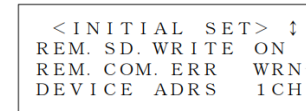

- Allow the setting of the device address for serial communication.
- Allows the selection of the control for pump operation: PUMP IV. FREQ: Pump frequency control. FLOW: Circulating fluid flow rate control. PRESS: Pump discharge pressure control.
- Allows the setting of pump discharge upper limit value. Can be turned on/off.

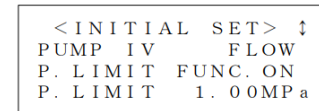

- Setting of buzzers during key input. Can be turned on/off.
- Setting of alarm buzzer. Can be turn on/off.

### 6 Outline Dimensions

#### 6.1 Dimensions of INR-495-042

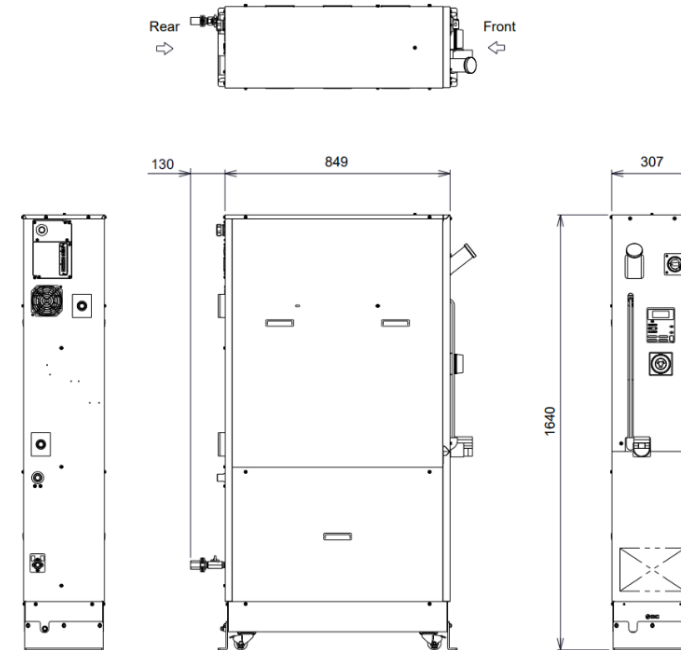

Note: Dimensions tolerance ±10 mm

### 7 Alarms and Troubleshooting

#### 7.1 Error Message

The following are to be performed in the event of an error in the system:

- The "ALARM" lamp comes on.
- Alarm buzzer comes on.
- The "Alarm Display screen" is displayed on the LCD screen.
- Error signal is issued through external communication.
- This system is brought to a stop forcefully according to error types.

#### 7.2 Troubleshooting

The procedure for error recovery varies with alarm types:

- Alarm Code 01 to 21, 25, to 29, 32: Eliminate the error cause. Press the [RESET] key on the operation display panel or power cycle the main breaker to enable error recovery to take effect.
- Alarm Code 22: Eliminate the error cause, and power cycle the main breaker to enable error recovery to take effect.
- Alarm Code 23: Automatic error recovery is implemented upon elimination of the error.

#### Alarm code list and troubleshooting:

Code	Error Message	Operation Condition	Cause	Remedies
01	Water Leak Detect FLT	Stop	The fluid is pooled at the base of this system.	Check for fluid leak.
03	RFGT High Press FLT	Stop	The pressure of the refrigerant circuit exceeded the specified value. Specified value = 12.5MPa	Check that facility water is being supplied to this product.
04	CPRSR Overheat FLT	Stop	The temperature in the compressor was excessive. Specified value = 110°C	Check that facility water is being supplied to this product.
05	Reservoir Low Level FLT	Stop	An insufficient amount of the circulating fluid is observed in the tank.	Replenish the circulating fluid.
06	Reservoir Low Level WRN	Continued	An insufficient amount of the circulating fluid is observed in the tank.	Replenish the circulating fluid.
07	Reservoir High Level WRN	Continued	An excessive amount of the circulating fluid is observed in the tank.	Drain the circulating fluid.

Code	Error Message	Operation Condition	Cause	Remedies
09	Reservoir High Temp. FLT	Stop	The temperature of the circulating fluid exceeded the specified value. Specified value = 80°C	Check the load specification.
10	Return High Temp WRN	Continued	The temperature of the circulating fluid exceeded the specified value. Specified value = 90°C	Check the circulating fluid flow rate, load specification.
11	Reservoir High Temp. WRN	Continued	The temperature of the circulating fluid exceeded your set value. Setting range: -20.0 to 75.0 °C. Factory default: 75.0 °C	Reset the setting temperature.
12	Return Low Flow FLT	Stop	The flow rate of the circulating fluid falls below specified value. Specified value = 6.0L/min	·Check that the external valve is opened. ·Prepare a thicker external pipe or install bypass piping
13	Return Low Flow WRN	Continued	The flow rate of the circulating fluid falls below your set value. Setting range: 6.1 to 40.0L/min. Factory default: 6.0L/min	Reset the setting flow rate.
15	Pump Breaker Trip FLT	Stop	The breaker for the circulating pump power line was tripped.	Check that the power supply to this product is compliant with the specification
16	CPRSR Breaker Trip FLT	Stop	The breaker for the compressor power line was tripped.	Check that the power supply to this product is compliant with the specification.
19	FAN Motor Stop WRN	Continued	The cooling fan inside the product has stopped.	Check that the air vent on the back of the product is not blocked off.
21	Controller Error FLT	Stop	An error was detected in the control system.	Contact the system supplier for request of inspection and repair.

## 7 Alarms and Troubleshooting (continued)

Code	Error Message	Operation Condition	Cause	Remedies
22	Memory Data Error FLT	Stop	An error was detected in data stored in the controller of this system.	<ul style="list-style-type: none"> <li>Re-turn ON the main breaker to recover from the error.</li> <li>Contact the system supplier for request of inspection and repair.</li> </ul>
23	Communication Error	0001	An interruption of serial communication occurred in this system.	Contact the system supplier for request of inspection and repair.
	Communication Error	8000	An interruption of serial communication occurred between this system and your system.	Contact the system supplier for request of inspection and repair.
25	Pump Inverter Error FLT	Stop	An error was detected in the inverter for circulating pump.	Contact the system supplier for request of inspection and repair.
26	F.Water Low Flow WRN	Continued	Continued 1. Facility water is insufficient. See Figure 1A Failure of flow meter.	<ol style="list-style-type: none"> <li>Check facility water specification.</li> <li>Check flow meter.</li> </ol>
27	F.Water Low Flow FLT	Stop	1. Facility water is insufficient. See Figure 1A. Failure of flow meter.	<ol style="list-style-type: none"> <li>Check facility water specification.</li> <li>Check flow meter.</li> </ol>
28	CPRSR INV Error FLT	Stop	An error was detected in the inverter for compressor.	Contact the system supplier for request of inspection and repair.

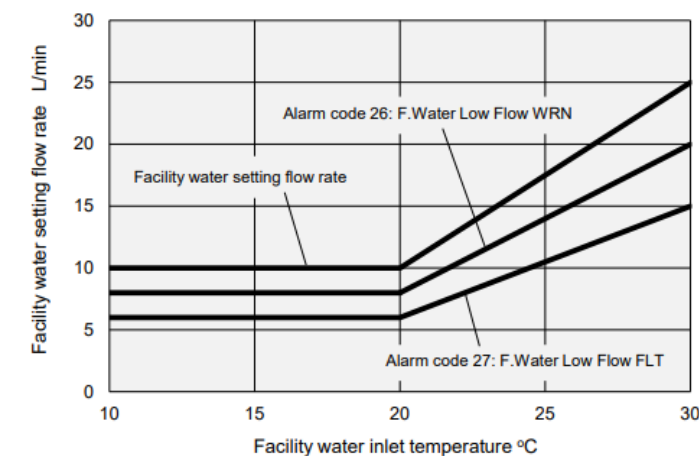

Figure 1A: Facility water flow rate drop alarm.

Code	Error Message	Operation Condition	Cause	Remedies
29	RFGT Low Press FLT	Stop	The refrigerant pressure falls below the specified value <sup>1</sup> .	Contact the system supplier for request of inspection and repair.
32	Reservoir Low Temp. WRN	Continued	The temperature of the circulating fluid falls your set value <sup>1</sup> .	Reset the setting temperature.

## 8 Maintenance

### 8.1 General maintenance

#### Caution

- Not following proper maintenance procedures could cause the product to malfunction and lead to equipment damage.

## 8 Maintenance (continued)

- Maintenance of this system should be performed only by qualified personnel.
- Before performing maintenance, turn off the power supply and be sure to cut off the facility water supply.
- After installation and maintenance, perform appropriate functional and leakage tests to make sure the equipment is installed correctly.
- If any electrical connections are disturbed during maintenance, ensure they are reconnected correctly, and safety checks are carried out as required to ensure continued compliance with applicable national regulations.
- Do not make any modification to the product.
- Do not disassemble the product, unless required by installation or maintenance instructions.

### 8.2 Water Quality Management

#### Caution

Only designated circulating fluid is permitted to use for this system. Potential system failure and fluid leak may occur if disregarded, which results in electric shock, ground fault, and freeze. Be sure to use fresh water (tap water) compliant with water quality standards for facility water. See operation manual Chapter 7 Control, Inspection and cleaning for full details.

#### Caution

If the periodic inspection finds a nonconforming substance in the facility water, clean the facility water circuit and recheck the quality of the facility water.

### 8.3 Inspection and cleaning

#### Warning

- Do not touch any electrical parts with wet hands. Keep wet hands away from electrical parts. Potential electric shock can occur if disregarded.
- Keep this system from water. Potential electric shock or fire can occur if disregarded.
- If the inspection and cleaning require the removal of the panel, be sure to re-attach the panel upon completion. Potential personal injury or electric shock may occur if operated with the panel opened or removed.

Inspection item	Inspection method	
Installation condition	Check of the condition of system installation	No heavy object is placed on this system. This system should not be subjected to external force. Temperature and humidity fall within the specified range.
Fluid leak	Check of the piping connector section	No leak of facility water and circulating fluid from the piping connector section
Fluid level	Reading of the level of the circulating fluid	Level falls within the circulating fluid specified level between "High" and "Low".
Operation display panel	Display check	Clarity of letters and numbers on the LCD display should be assured.
	Function check	[RUN] lamp is ON.
Circulating fluid temperature	Confirm the reading on the LCD screen	Temperature should be within setpoint.
Refrigerant pressure	Reading of the refrigerant pressure gauge	Value of "HI PRESS" in see operation "5.3.27 Maintenance screen 6" should be in the following range.4.09 to 9.0MPa
Discharge pressure of circulating fluid	Confirm the reading on the LCD screen	Reading should not have deviated much from last inspection.
Circulating fluid flow rate	Confirm the reading on the LCD screen	Reading should not have deviated much from last inspection.
Operating condition	Operating condition check	No abnormal noise, vibration, odour, and smoke
Facility water	Check of the facility water	Temperature, flow rate and pressure fall within the specified range.
Circulating fluid supply port cap	Check by providing manual tightening	No looseness

### 8.3.1 Quarterly Inspection

#### Warning

Quarterly inspection requires an advance lockout/tagout of this product. See section 1.5.3 in the operation manual.

## 8 Maintenance (continued)

Inspection item	Inspection method
Circulating fluid	Circulating fluid is to be drained for check. Fluid should be free of particles, moisture <sup>1</sup> and foreign substances.
	For ethylene glycol solution, confirm that the concentration falls within the specified range.
	Recommended to replace the water.
Facility water	Facility water quality should fall within the standards specified.
Ventilation hole and electrical parts	No particles and dust should be present.

#### Caution

Moisture trapped in the fluorinated fluid (\*1) freezes in the heat exchanger element and piping, which may lead to system failure.

### 8.4 Storage

The following should be performed for system long-term storage.

- Drain circulating fluid.
- Drain facility water.
- Cover the system with a plastic sheet for storage.

#### 8.4.1 Draining of Circulating Fluid out of Tank

#### Warning

- If the recovered circulating fluid is contaminated by foreign substances, completely remove them. Do not reuse contaminated fluid.
- Potential insufficient cooling, system failure and froth in the circulating fluid may occur if disregarded.
- Recovered circulating fluid must be sealed in a container to prevent contamination from moisture or foreign substances.
- Store in a cool, dark place.
- Keep it from flame.

#### Caution

- Use the clean container for circulating fluid recovery. Reuse of the recovered circulating fluid with contaminated will cause insufficient cooling and system failure.
- Be sure to wait until the circulating fluid obtains room temperature for its draining. Potential burns and dew intrusion may occur if disregarded.

- Prepare the container for circulating fluid recovery at the back of this product.
- Connect the drain hoses to the drain tank drain port. Insert the tip of the hose into the container.
  - Prepare a drain hose (Rc3/8-diameter) on your responsibility.
- Remove the cap of the circulating fluid port.
- Open the value tank drain port to drain the circulating fluid.
- Purge the circulating fluid remaining in the heat exchange by air to return it to the reservoir and drain it. (Pressure: 50kPa)

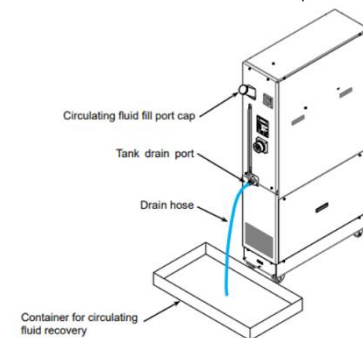

- Upon completion of fluid draining, close the value tank drain port.
- Add plugs to seal off ports on the rear of this system.

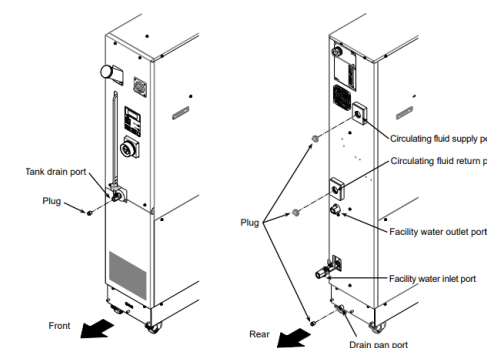

## 8 Maintenance (continued)

### 8.4.2 Draining of Facility Water

#### Caution

Be sure to drain the facility water only when it is at room temperature. Trapped fluid inside the system can still be hot. Potential burns can occur if disregarded.

- Place the drain pan underneath the piping connections on the rear of this product.
  - A 7L-capacity or bigger drain pan is required.
- Remove facility water piping.
  - Remove the joints such as unions if present.
- Drain the facility water using the facility water inlet/outlet ports.

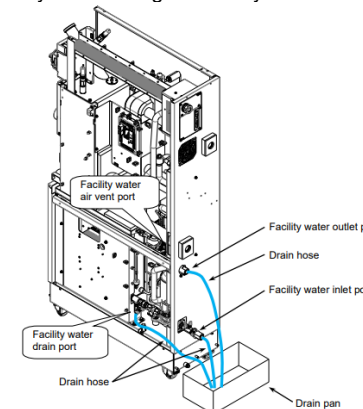

### 8.5 Periodic Replacement Parts

Replacement of consumables listed in the following table is recommended.

Part	Recommended replacement cycle
Circulating pump	Every 3 years
Ventilation fan	Every 3 years
Inverter cooling fan	Every 3 years

\*Note: A replacement cycle may vary depending on operation conditions.

## 9 Limitations of Use

### 9.1 Limited warranty and disclaimer/compliance requirements

Refer to Handling Precautions for SMC Products.

## 10 Product Disposal

This product shall not be disposed of as municipal waste. Check your local regulations and guidelines to dispose this product correctly, in order to reduce the impact on human health and the environment.

## 11 Declaration of Conformity

Below is a sample Declaration of Conformity (DoC) used in this product.

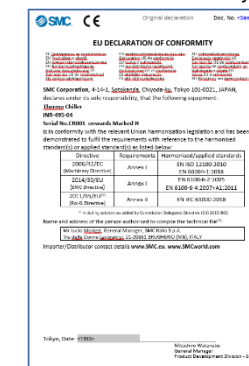

## 12 Contacts

Refer to [www.smcworld.com](http://www.smcworld.com) or [www.smc.eu](http://www.smc.eu) for your local distributor/importer.

## SMC Corporation

URL : <https://www.smcworld.com> (Global) <https://www.smc.eu> (Europe)  
 SMC Corporation, 4-14-1, Sotokanda, Chiyoda-ku, Tokyo 101-0021, Japan  
 Specifications are subject to change without prior notice from the manufacturer.  
 © SMC Corporation All Rights Reserved.  
 Template DKP50047-F-085N