



Instruction Manual

Auto switch (Solid state) – Trimmer type

Series D-M9K / D-F7K / D-Y7K (Sensor)

D-RNK / D-RPK (Amplifier)



The intended use of the auto switch is to detect and control the position of an actuator using magnetic detection.

1 Safety Instructions

These safety instructions are intended to prevent hazardous situations and/or equipment damage. These instructions indicate the level of potential hazard with the labels of "Caution," "Warning" or "Danger." They are all important notes for safety and must be followed in addition to International Standards (ISO/IEC)¹⁾, and other safety regulations.

- ¹⁾ ISO 4414: Pneumatic fluid power - General rules relating to systems.
 - ISO 4413: Hydraulic fluid power - General rules relating to systems.
 - IEC 60204-1: Safety of machinery - Electrical equipment of machines. (Part 1: General requirements)
 - ISO 10218-1: Manipulating industrial robots -Safety. etc.
- Refer to product catalogue, Operation Manual and Handling Precautions for SMC Products for additional information.
 - Keep this manual in a safe place for future reference.

	Caution	Caution indicates a hazard with a low level of risk which, if not avoided, could result in minor or moderate injury.
	Warning	Warning indicates a hazard with a medium level of risk which, if not avoided, could result in death or serious injury.
	Danger	Danger indicates a hazard with a high level of risk which, if not avoided, will result in death or serious injury.

Warning

- Always ensure compliance with relevant safety laws and standards.
- All work must be carried out in a safe manner by a qualified person in compliance with applicable national regulations.
- This product is class A equipment intended for use in an industrial environment. There may be potential difficulties in ensuring electromagnetic compatibility in other environments due to conducted or radiated disturbances.
- Refer to the operation manual on the SMC website (URL: <https://www.smcworld.com>) for all Safety Instructions.

Warning

- Special products (-X or -####) might have specifications different from those shown in the Specifications section. Contact SMC for specific drawings.

2 Specifications

2.1 Sensor unit specifications

Model	D-M9K	D-F7K	D-Y7K
Mounting	Direct mounting (round groove)	Rail mounting	Direct mounting (square groove)
Applicable amplifier	D-RNK, D-RPK		
Impact resistance	980 m/s ²		
Insulation resistance	50 MΩ or more, test voltage 500 VDC (between case and cable)		
Withstand voltage	1000 VAC, 1 min (between case and cable)		
Ambient temperature	-10 to 60 °C		
Enclosure	IP67 to IEC60529		
Weight (with connector)	55 g		58 g

2.2 Cable specifications (sensor and amplifier cable)

Sheath	Outside diameter	φ3.5 mm
Insulator	Colours	Brown, Blue, Black, White
	Diameter	φ1 mm
Conductor	Nominal cross section area	0.15 mm ² (AWG26)
	Wire diameter	φ0.08 mm
Minimum bending radius (reference value)		21 mm

2.3 Amplifier unit specifications

Model	D-RNK	D-RPK
Applicable sensor	D-M9K, D-Y7K, D-F7K	
Applicable load	Relay / PLC	
Voltage output	12 to 24 VDC	
Current output	40 mA or less	
Output type	NPN (2 output)	PNP (2 output)
Load voltage	28 V or less	-
Load current	80 mA or less / 1 output	
Internal voltage drop	1.5 V or less	
Leakage current	100 μA or less / 1 output	
Response time	1 ms or less	
Impact resistance	98 m/s ²	
Insulation resistance	50 MΩ or more, test voltage 500 VDC (between case and cable)	
Withstand voltage	1000 VAC, 1 min (between case and cable)	
Ambient temperature	-10 to 60 °C	
Enclosure	IP40 to IEC 60529	
Weight	70 g	

3 Names of Individual parts

3.1 Sensor unit

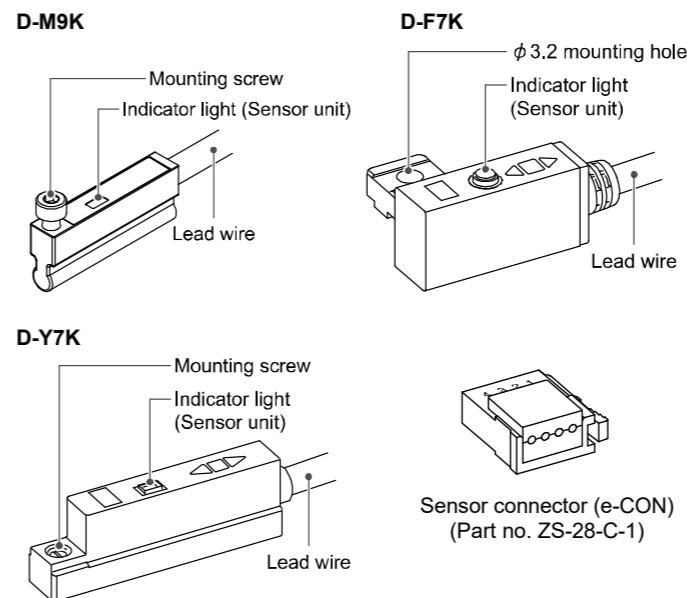

Part	Description
Mounting screw	Screw for securing the sensor unit in the groove in the actuator.
φ3.2 mounting hole	Hole for mounting the sensor to the actuator rail. (use mounting bracket included with actuator).
Indicator light (Sensor unit)	Indicator LED is ON (red or green) when the sensor unit detects the magnetic field.
Lead wire	Lead wire for power supply and outputs (3 m).
Sensor connector (e-CON)	Sensor Connector supplied loose with the product.

3.2 Amplifier unit

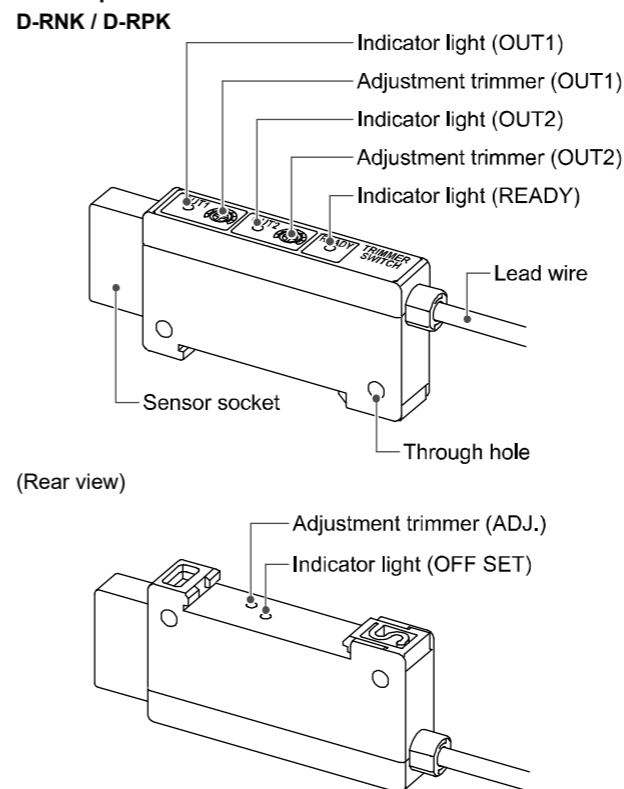

3 Names of Individual parts (continued)

Part	Description
Indicator light (OUT1)	Indicates the output status of OUT1. The LED is ON (Green) when the output is ON.
Adjustment trimmer (OUT1)	For adjusting the detection range of OUT1.
Indicator light (OUT2)	Indicates the output status of OUT2. The LED is ON (Orange) when the output is ON.
Adjustment trimmer (OUT2)	For adjusting the detection range of OUT2.
Indicator light (READY)	The READY LED is ON (Red) when the sensor unit detects the magnetic field. The detection ranges of OUT1 and OUT2 should be adjusted when this LED is ON.
Lead wire	Lead wire for power supply and outputs (3 m).
Through hole	Hole for direct mounting.
Sensor socket	For connecting the sensor.
Adjustment trimmer (ADJ)	For adjusting the sensor unit when it is connected for the first time.
Indicator light (OFFSET)	The OFFSET LED is ON (Red) when the adjustment is completed.

4 Installation

4.1 Installation



- Do not install the product unless the safety instructions have been read and understood.

4.2 Design and Selection

- Confirm the specifications.
Read the specifications carefully and use the product correctly. The product may be damaged or malfunction if it is used outside of the specification range.
- Take precautions when multiple actuators are used close together.
When multiple actuators are used in close proximity, magnetic field

interference may cause the switches to malfunction. Maintain a minimum actuator separation of 40 mm.

- Pay attention to the length of time that a switch is ON at an intermediate stroke position.
When a sensor is placed at an intermediate position of the stroke and a load is driven at the time the piston passes, the sensor will operate, but if the speed is too great the operating time will be short and the load may not operate correctly. The maximum detectable piston speed is:

$$V \text{ (mm/s)} = \frac{\text{Sensor operating range (mm)}}{\text{Load operating time (ms)}} \times 1000$$

- Keep wiring as short as possible
Although a long wire length does not affect the switch function, it is recommended to keep it to 100 m or less.
The sensor cable length should be 3 m or less.
- Do not use a load that generates a surge voltage.
When a load which generates a surge voltage is to be directly driven, operating for example a relay or solenoid, use a product with built-in surge protection.
- Caution for use in an interlock circuit
When an auto switch is used for an interlock signal requiring high reliability, devise a double interlock system by providing a mechanical protection function, or by using another switch (sensor) together with the auto switch.
- Pay attention to the internal voltage drop of the product.
When sensors are connected in series, the voltage drop will be "n" times larger when "n" products are connected. Even though a product may operate normally, the load may not operate.
- The product output will be unstable for 50 ms after power is supplied.
During the time after supplying power, the input device (e.g. PLC, relay) may consider the ON position as an OFF output or the OFF position as an ON output. Please set up the application to consider the signals will be invalid within 50 ms after power is supplied.

4 Installation (continued)

4.3 Mounting and Adjustment

- Do not cause impact to the product.
Do not drop, bump or apply excessive impact while handling (sensor 980 m/s², amplifier: 98 m/s²). Although the body of the product may not appear damaged, the inside could be damaged and cause a malfunction.
- Observe the required tightening torque for mounting the product.
If the product is tightened beyond the specified tightening torque, the product, mounting screws, or mounting bracket may be damaged.
Tightening below the specified tightening torque will allow the product to move out of position.
- Use only the screws installed in the product body for mounting the product. If other screws are used, the product may be damaged.
- Position the sensor based on the instructions for the actuator.
Mounting the product close to the edge of its operating range (close to the border of ON/OFF operation) may cause unstable operation. Some actuator and cylinder series have their own setting methods. In such cases, follow the instructions given.

4.4 Environment

Warning

- Do not use in an environment where oil, corrosive gases, chemicals, salt water or steam are present.
- Do not install in a location subject to vibration or impact in excess of the product specifications.
- Do not mount in a location exposed to radiant heat that would result in temperatures in excess of the product specification.
- Do not use in an area where a magnetic field is generated.
Auto switches can malfunction or magnets inside actuators can become demagnetized.
- Do not use in an environment where the auto switch will be continually exposed to water.
- Do not use in an environment with temperature cycles.
- Avoid accumulation of iron waste or close contact with magnetic substances. A large amount of accumulated iron waste such as machining chips or spatter may cause the auto switch to malfunction.

4.5 Mounting

4.5.1 Installation of the Amplifier unit

Caution

Perform offset adjustment before the installation of the amplifier unit.

Direct mounting

- For direct mounting use M3 screws (2 pcs.) or equivalent.
- The recommended tightening torque of the screw is 0.5 to 0.7 N•m.
- Mount the product on a flat and even surface. Mounting on an uneven surface can damage the case.
- Screws and washers should be supplied by the user.

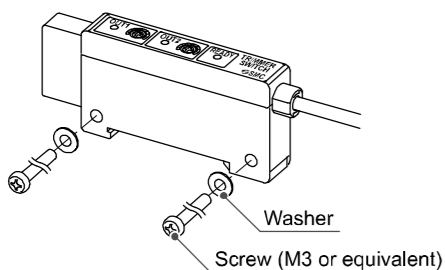

DIN Rail mounting

- Hook the claw part 1 to the DIN rail (35 mm width).
- Push the claw part 2 down until it clicks.

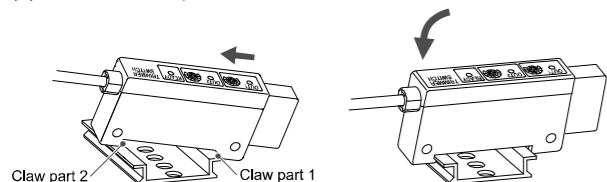

- For removal, push the product body towards the sensor socket end, and pull the sensor socket end of the product upwards.

5 Wiring

5.1 Wiring

- Connections should only be made with the power supply turned OFF.
- Confirm proper insulation of wiring.
Check that there is no faulty wiring insulation (contact with other circuits, ground fault, improper insulation between terminals, etc.)
- Do not route wiring with power lines or high voltage lines.
Avoid parallel wiring or wiring in the same conduit with these lines. Control circuits containing auto switches may malfunction due to noise.
- Ensure that the FG terminal is connected to ground when using a commercially available switch-mode power supply. When a switch-mode power supply is connected to the product, switching noise will be superimposed and the product specification can no longer be met. This can be prevented by inserting a noise filter, such as a line noise filter and ferrite core, between the switch-mode power supply and the product, or by using a series power supply instead of a switch-mode power supply.

5.2 Wiring connection

- Attach the sensor connector to the sensor wire.
- Strip the sensor cable sheath as shown.
- Do not cut the insulator.

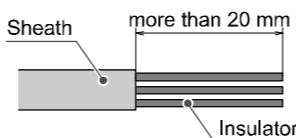

- Insert the corresponding wire colour shown in the table into the pin number printed on the sensor connector, to the bottom.

Pin number	Wire colour	Signal
1	Black	SOUT1
2	Blue	GND
3	White	SOUT2
4	Brown	Vsw

- Check that the above preparation has been performed correctly, then part A shown should be pressed in by hand to make temporary connection.
- Part A should then be pressed in using a suitable tool, such as pliers.

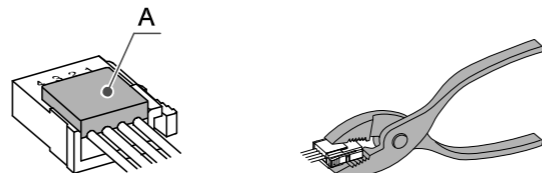

- The sensor connector cannot be re-used once it has been fully crimped.
- In case of connection failure such as incorrect order of wires or incomplete insertion, use a new connector (SMC Part no. ZS-28-C-1).

5.3 Sensor connection to amplifier unit

- When installing the connector, insert it straight into the socket until the connector clicks.
- When removing the connector, press down the lever to release the hook from the sensor socket and pull the connector straight out.

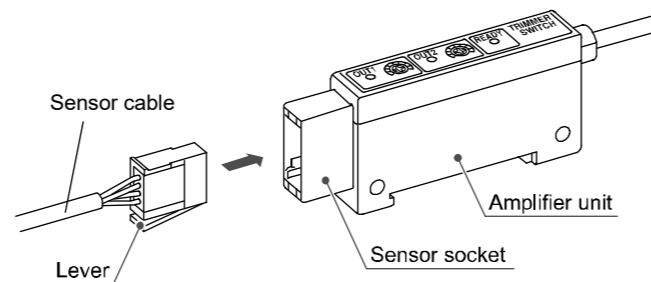

5 Wiring (continued)

5.4 Internal Circuit and wiring

5.4.1 Sensor unit (D-M9K / D-F7K / D-Y7K)

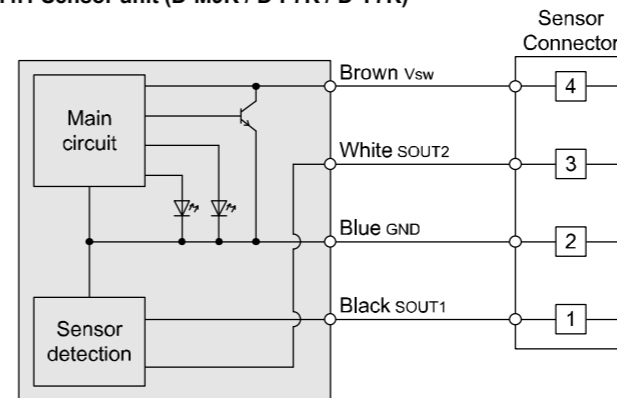

5.4.2 Amplifier unit

D-RNK NPN (2 output) type

Max. load current: 80 mA Max. applied voltage: 28 V
Internal voltage drop: 1.5 V or less

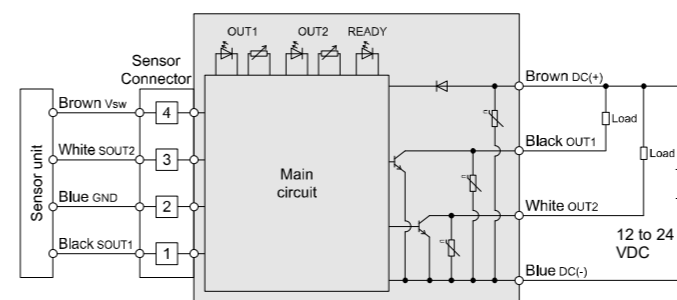

D-RPK NPN (2 output) type

Max. load current: 80 mA
Internal voltage drop: 1.5 V or less

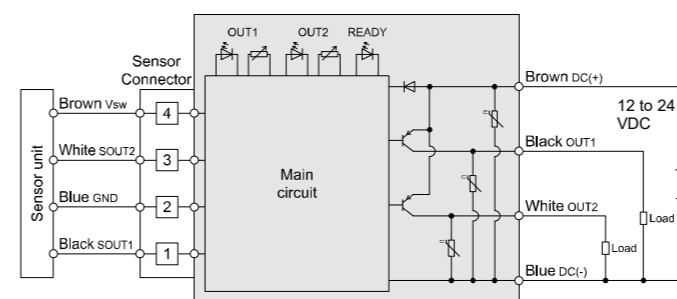

6 Setting

6.1 Offset Adjustment

Caution

- During offset adjustment, the sensor unit should not be mounted to an actuator, so that no magnetic field is present. Keep the sensor unit away from any magnetic field as far as possible because the sensor may detect a magnetic field even when the operation light is not ON.

- Connect the sensor unit to the amplifier unit and connect the amplifier unit to the power supply.
- Insert a small flat blade screwdriver into the adjustment trimmer (ADJ) to turn the trimmer clockwise or counterclockwise.
Be careful where the screwdriver is inserted. Inserting the screwdriver into the indicator light (OFFSET) hole may damage the light.
The recommended torque applied to the adjustment trimmer must be 20 mN•m or less. The effective rotation is 12 turns.

6 Setting (continued)

- The adjustment trimmer does not have any rotational stop. If the desired adjustment is not achieved by rotating in one direction, then try the other direction.
- When the indicator light (OFFSET) is Red, adjustment is complete.

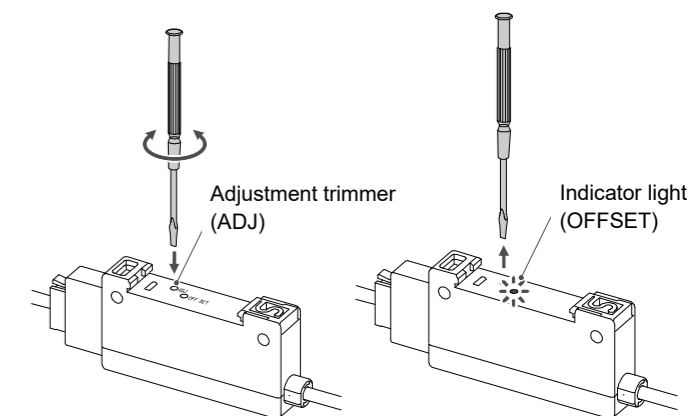

Offset Adjustment

- Offset Adjustment is the optimization of the electrical reference point of the sensor.
- Without offset adjustment, ON/OFF of the output signal cannot be operated correctly.
- When the sensor unit is used for the first time, always perform offset adjustment.
- After the adjustment, further adjustment is not necessary unless the sensor unit is replaced.

6.2 Setting using the Adjustment Trimmer

"How to mount" depends on the actuator type and bore size. Please refer to the actuator catalogue.
The size of the work piece (correct, too small, too large, or no work piece) can be verified by setting the detection range of OUT1 and OUT2 within the operation range using the adjustment trimmer. (See below)

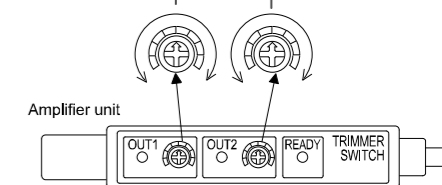
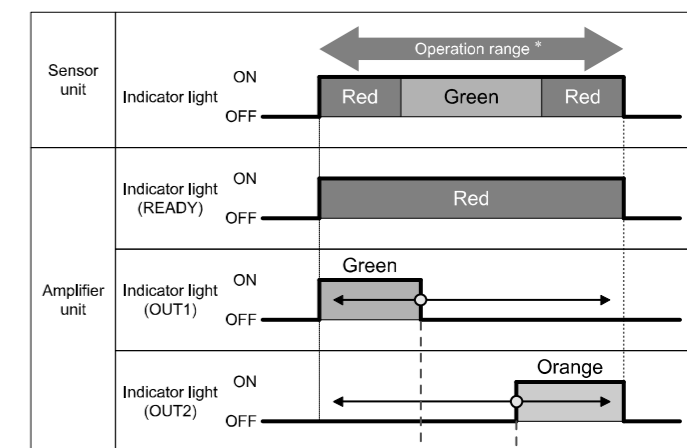

* For standard products, the operating range depends on the actuator and bore size. It cannot be varied.

6 Setting (continued)

- The maximum recommended torque applied to the adjustment trimmer is 2 to 20 mN·m. The maximum rotation is 260 degrees. Make the adjustment within the specification range.
- The scale of the trimmer does not show the operation range. Please only use this as a guide for setting.

Caution

- For setting, do not move the actuator by hand. Use air to start the actuator.
- The Detection range may vary depending on the air supply pressure, variation of the ambient magnetic field, or the presence of any magnetic material.
- The Minimum detection distance is 0.5 mm. This product is not suitable when the size difference of the work piece is less than 0.5 mm in the stroke direction.
- This product is not suitable for work pieces with unstable shapes such as rubber parts.

6.2.1 Setting Procedure 1

- The following is an example setting procedure.
- Perform the setting and operation check according to the actual equipment.

<< Verify 4 work pieces below using Actuator (CQ2 series) >>

[A]	Work piece size is correct
[B]	Work piece is too large
[C]	Work piece is too small
[D]	No work piece

- (1) Push the largest conformant work piece by supplying air to the actuator.

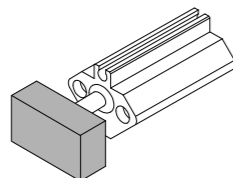

- (2) Insert the sensor unit up to the end of the mounting groove.

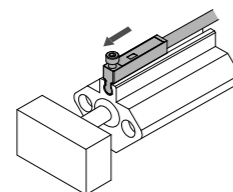

* The relationship between OUT1 and OUT2 is reversed if the mounting direction is opposite. The Detection range may change. An operation check with actual equipment should be performed as the location of OUT1 and OUT2 is reversed depending on the cylinder structure.

- (3) Pull back the sensor unit. Position the sensor unit where the indicator light changes from red to green.

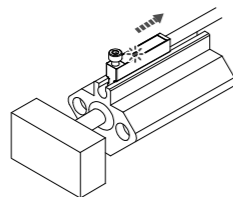

- (4) Make sure that the indicator light (READY) on the amplifier unit is ON.
 (5) Fix the sensor unit using the mounting screw or a mounting bracket. Refer to the table below for the tightening torque.

Model	Mounting	Mounting tool	Tightening torque
D-M9K	Hexagon socket head cap screw (M2.5 x 12 L)	Hexagon driver (size 2 mm)	0.1 to 0.2 N·m
D-F7K	Mounting bracket + Mounting screw (M3)	Phillips head screwdriver	0.5 to 0.7 N·m
D-Y7K	Mounting screw (M2.5 x 4 L)	Small flat blade screwdriver	0.05 to 0.1 N·m

6 Setting (continued)

- (6) Turn the adjustment trimmer (OUT1) with a screwdriver. Stop turning the screwdriver when the indicator light (OUT1) is ON. If the indicator light (OUT1) is already ON, turn the trimmer to turn OFF the light, then adjust the trimmer.

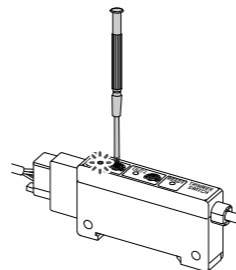

- (7) Replace the pushed work piece with the smallest conformant work piece.

- (8) Turn the adjustment trimmer (OUT2) with a screwdriver. Stop turning the screwdriver when the indicator light (OUT2) is ON. If the indicator light (OUT2) is already ON, turn the trimmer to turn OFF the light, then adjust the trimmer.

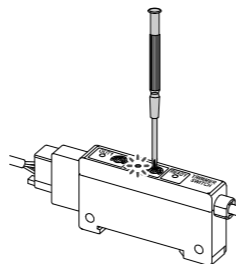

Workpiece Verification

	OUT1 output (Detects the upper limit of the work piece)	OUT2 output (Detects the lower limit of the work piece)
[A] Work piece size is correct (Conformant range)	ON (Work piece is smaller than the upper limit. Conformance)	ON (Work piece is larger than the lower limit. Conformance)
[B] Work piece is too small	ON (Work piece is smaller than the upper limit. Conformance)	OFF (Work piece is smaller than the lower limit. Non-conformance)
[C] Work piece is too large	OFF (Work piece is larger than the upper limit. Non-conformance)	ON (Work piece is larger than the lower limit. Conformance)
[D] No work piece	OFF (Work piece is larger than the upper limit. Non-conformance)	OFF (Work piece is smaller than the lower limit. Non-conformance)

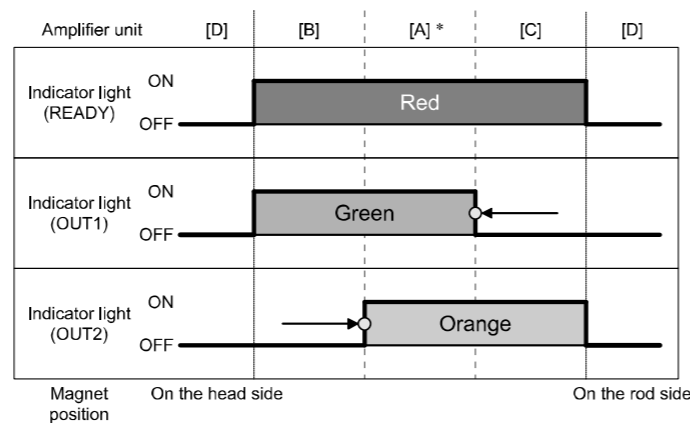

* Dimension for [A] should be 0.5 mm minimum in the stroke direction.

6 Setting (continued)

6.2.2 Setting Procedure 2

- The following is an example setting procedure.
- Perform the setting and operation check according to the actual equipment.

<<Verify 4 work pieces below using Air Gripper (MHZ2 series)>>

[A]	Work piece size is correct
[B]	Work piece is too small
[C]	Work piece is too large
[D]	No work piece

- (1) Hold the minimum conformant work piece by supplying air to the gripper.

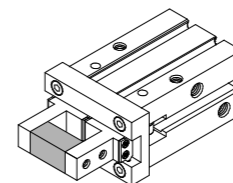

- (2) Insert the sensor unit up to the end of the mounting groove.

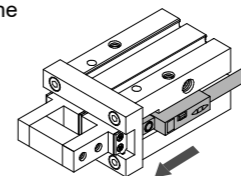

* The relationship between OUT1 and OUT2 is reversed if the mounting direction is opposite. The Detection range may change. An operation check with actual equipment should be performed as the location of OUT1 and OUT2 is reversed depending on the cylinder structure.

- (3) Pull back the sensor unit. Position the sensor unit where the indicator light changes from red to green.

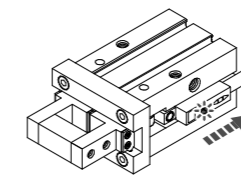

- (4) Make sure that the indicator light (READY) on the amplifier unit is ON.
 (5) Fix the sensor unit using the mounting screw or a mounting bracket. Refer to the table below for the tightening torque.

Model	Mounting	Mounting tool	Tightening torque
D-M9K	Hexagon socket head cap screw (M2.5 x 12L)	Hexagon driver (size 2 mm)	0.1 to 0.2 N·m
D-F7K	Mounting bracket + Mounting screw (M3)	Phillips head screwdriver	0.5 to 0.7 N·m
D-Y7K	Mounting screw (M2.5 x 4L)	Small flat blade screwdriver	0.05 to 0.1 N·m

- (6) Turn the adjustment trimmer (OUT1) with a screwdriver. Stop turning the screwdriver when the indicator light (OUT1) is ON. If the indicator light (OUT1) is already ON, turn the trimmer to turn OFF the light, then adjust the trimmer.

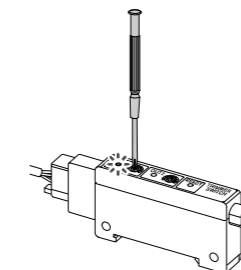

- (7) Replace the pushed work piece with the maximum conformant work piece.

- (8) Turn the adjustment trimmer (OUT2) with a screwdriver. Stop turning the screwdriver when the indicator light (OUT2) is ON. If the indicator light (OUT2) is already ON, turn the trimmer to turn OFF the light, then adjust the trimmer.

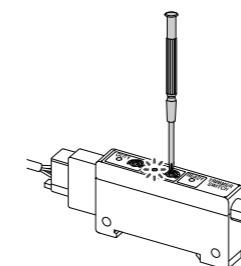

6 Setting (continued)

Workpiece Verification

	OUT1 output (Detects the lower limit of the work piece)	OUT2 output (Detects the upper limit of the work piece)
[A] Work piece size is correct (Conformant range)	ON (Work piece is larger than the lower limit. Conformance)	ON (Work piece is smaller than the upper limit. Conformance)
[B] Work piece size is too large	ON (Work piece is larger than the lower limit. Conformance)	OFF (Work piece is larger than the upper limit. Non-conformance)
[C] Work piece size is too small	OFF (Work piece is smaller than the lower limit. Non-conformance)	ON (Work piece is smaller than the upper limit. Conformance)
[D] No work piece	OFF (Work piece is smaller than the lower limit. Non-conformance)	OFF (Work piece is larger than the upper limit. Non-conformance)

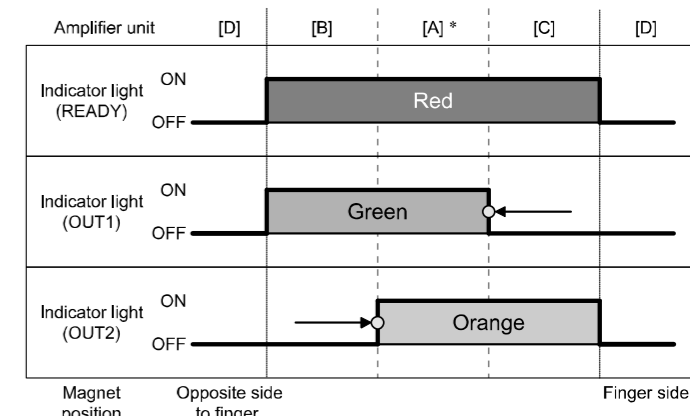

* Dimension for [A] should be 0.5 mm minimum in the stroke direction.

7 How to Order

Refer to the catalogue or operation manual on the SMC website (URL: <https://www.smcworld.com>) for How to order information.

8 Outline dimensions

Refer to the catalogue or operation manual on the SMC website (URL: <https://www.smcworld.com>) for outline dimensions.

9 Maintenance

9.1 General Maintenance

Caution

- Not following proper maintenance procedures could cause the product to malfunction and lead to equipment damage.
- If handled improperly, compressed air can be dangerous.
- Maintenance of pneumatic systems should be performed only by qualified personnel.
- Before performing maintenance, turn off the power supply and be sure to cut off the supply pressure. Confirm that the air is released to atmosphere.
- After installation and maintenance, apply operating pressure and power to the equipment and perform appropriate functional and leakage tests to make sure the equipment is installed correctly.
- If any electrical connections are disturbed during maintenance, ensure they are reconnected correctly and safety checks are carried out as required to ensure continued compliance with applicable national regulations.
- Do not make any modification to the product.
- Do not disassemble the product, unless required by installation or maintenance instructions.
- Perform the following maintenance periodically in order to prevent possible danger due to unexpected auto switch malfunction.
 - 1) Securely tighten switch mounting screws. If screws become loose or the mounting position is dislocated, re-tighten them after readjusting the mounting position.
 - 2) Confirm that there is no damage to lead wires. To prevent faulty insulation, replace switches or repair lead wires, etc., if damage is discovered.

How to reset the product after a power cut or when the power has been unexpectedly removed

Regarding set up, contents of the program may be maintained by the customer's application systems. Be sure to confirm safety when returning operation of the actuator because it could have been stopped in an unstable condition.

Perform the following maintenance regularly to avoid possible danger due to unexpected product malfunction.

- Make sure that the Adjustment trimmer of the amplifier unit is set in the correct setting position.
- Check if the mounting bracket or mounting screws are loose.
If the mounting bracket or mounting screws are loose, tighten them using the appropriate tightening torque.
- Make sure that the cable is not damaged.
A damaged cable may lead to insulation failure. Repair the cable or replace the product.

10 Limitations of Use

10.1 Limited warranty and Disclaimer/Compliance Requirements

Refer to Handling Precautions for SMC Products.

11 Product disposal

This product should not be disposed of as municipal waste. Check your local regulations and guidelines to dispose of this product correctly, in order to reduce the impact on human health and the environment.

12 Contacts

Refer to www.smcworld.com or www.smc.eu for your local distributor / importer.

SMC Corporation

URL: <https://www.smcworld.com> (Global) <https://www.smceu.com> (Europe)
SMC Corporation, 4-14-1, Sotokanda, Chiyoda-ku, Tokyo 101-0021, Japan
Specifications are subject to change without prior notice from the manufacturer.
© 2021 SMC Corporation All Rights Reserved.
Template DKP50047-F-085M