



ORIGINAL INSTRUCTIONS

## Instruction Manual

### Stroke Reading Cylinder

#### CE1\*\*-\* series



The intended use of this product is to convert an electrical signal into mechanical motion and provide position feedback signal using a sensor.

### 1 Safety Instructions

These safety instructions are intended to prevent hazardous situations and/or equipment damage. These instructions indicate the level of potential hazard with the labels of "Caution," "Warning" or "Danger." They are all important notes for safety and must be followed in addition to International Standards (ISO/IEC)<sup>(1)</sup>, and other safety regulations.

- <sup>(1)</sup> ISO 4414: Pneumatic fluid power - General rules relating to systems.  
 ISO 4413: Hydraulic fluid power - General rules relating to systems.  
 IEC 60204-1: Safety of machinery - Electrical equipment of machines. (Part 1: General requirements)  
 ISO 10218-1: Robots and robotic devices - Safety requirements for industrial robots - Part 1: Robots.
- Refer to product catalogue, Operation Manual and Handling Precautions for SMC Products for additional information.
  - Keep this manual in a safe place for future reference.

<b>Caution</b>	Caution indicates a hazard with a low level of risk which, if not avoided, could result in minor or moderate injury.
<b>Warning</b>	Warning indicates a hazard with a medium level of risk which, if not avoided, could result in death or serious injury.
<b>Danger</b>	Danger indicates a hazard with a high level of risk which, if not avoided, will result in death or serious injury.

### Warning

- Always ensure compliance with relevant safety laws and standards.**
- All work must be carried out in a safe manner by a qualified person in compliance with applicable national regulations.
- The compatibility of pneumatic equipment is the responsibility of the person who designs the pneumatic system or decides its specifications.
- Do not service machinery / equipment or attempt to remove components until safety is confirmed.
- Do not use the product outside of the specifications.
- Refer to the operation manual or catalogue on the SMC website (URL: <https://www.smcworld.com>) for further Safety Instructions.
- Special products (-X) might have specifications different from those shown in the specifications section. Contact SMC for specific drawings.

## 2 Specifications

- The Stroke Reading Cylinder is a cylinder with a built-in linear encoder.
- The scale of the magnetic rod and magnetic sensor detects changes in piston position, and a pulse signal is output using an A/B quadrature pulse (90° nominal phase relationship).
- Position detection to 0.1 mm resolution is possible by inputting this signal to a CEU5 Multi Counter.

### 2.1 Cylinder specifications

Action	Double acting, single rod (Non-rotating piston rod)		
Fluid	Air		
Proof pressure	1.5 MPa		
Max. operating pressure	1.0 MPa		
Min. operating pressure	Ø12 0.07 MPa	Ø20 to 63 0.1 MPa	
Operating piston speed	70 to 500 mm/s		
Ambient & fluid temperature	0 to 60° (no freezing)		
Humidity	25 to 85% RH (no condensation)		
Lubrication	Non-lube		
Stroke tolerance range	Ø12 to 20 : 0 to +1.0 mm	Ø32 to 63 : 0 to +1.6 mm	
Cushion	Ø12 to 32: None	Ø40 to 63: Selectable	
Rod non-rotating accuracy	Ø12: ±2°	Ø20: ±1°	Ø32 to 63: ±0.8°
Mounting	Direct mounting front end tapped (standard), Foot type, Front rear flange type, Double clevis type		
Thread tolerance	According to JIS class 2		

### 2.2 Sensor specifications

Item	Specification
Cable	Ø7, 6-core twisted pair shielding wire (Heat resistance, oil resistance, flameproof)
Max. cable length	23 m <sup>(1)</sup>
Position detection method	Incremental encoder (rod with magnetic scale, magnetic sensor)
Magnetic field resistance	14.5 mT
Power supply	12 to 24VDC ±10%, ripple: 1% or less
Current consumption	40 mA
Resolution	0.1 mm (at CEU5)
Accuracy	±0.2 mm (at 20°C) <sup>(2)</sup>
Output type	Open collector (24 VDC, 40 mA max.)
Output signal	A/B quadrature pulse (90° nominal phase relationship)
Insulation resistance	500 VDC, 50 MΩ or more (case: between 12E)
Vibration proof	33.3 Hz, 66.7 m/s <sup>2</sup> , 2 hours each in X and Y directions, 4 hours in Z direction, to JIS D1601
Impact resistance	294.2 m/s <sup>2</sup> , 3 times each in X, Y and Z directions
Enclosure	IP65 (IEC60529 standard) <sup>(3)</sup>

- <sup>(1)</sup> When an SMC cable and SMC CEU5 counter are used.  
<sup>(2)</sup> Including errors due to digital indication at Counter CEU5. The overall measurement accuracy after being mounted to the equipment may vary depending on the mounting environment. When accuracy of the equipment as a whole is required, calibration should be performed by the end users.  
<sup>(3)</sup> The cylinder section does not have a water-resistant enclosure.

## 3 Installation

### 3.1 Installation

#### Warning

- Do not install the product unless the safety instructions have been read and understood.
- Do not apply torque to the piston rod. Applying torque to the piston rod may cause damage and malfunction. When hardware and nuts are screwed on to the piston rod end, the piston rod should be fully retracted. Use double nuts to fix the work since the Scale Reading Cylinder does not have any parallel parts at the rod.

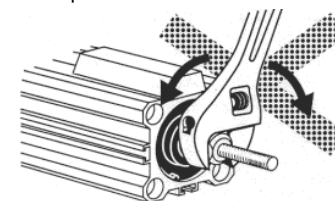

- Refer to the table below for maximum torque applied.

Ø12	10 N·m
Ø20 to 32	20 N·m
Ø40, Ø50, Ø60	30 N·m

- Ensure that the equipment operates properly before use.
- When installing the product, always allow space for maintenance.
- Do not apply strong impact and / or excessive moment when work is mounted. External force other than the allowable moment may cause rattle at the guide part and / or increase in sliding resistance.
- Use the product in such a condition that load is always applied in the axial direction to the piston rod. When load is applied in other directions, regulate the load itself using a guide. Perform a complete centering when the cylinder is mounted.
- Avoid using the product where the piston rod is subjected to a constant torque or where excessive impact is applied to the piston rod.
- Avoid scratches or dents on the sliding part of the piston rod.

### 3.2 Environment

#### Warning

- Do not use in an environment where corrosive gases, chemicals, salt water or steam are present.
- Do not use in an explosive atmosphere.
- Do not expose to direct sunlight. Use a suitable protective cover.
- Do not install in a location subject to vibration or impact in excess of the product specifications.
- Do not mount in a location exposed to radiant heat that would result in temperatures in excess of the product's specifications.
- Do not use in a place where condensation occurs due to sudden temperature change.
- Do not use in an atmosphere containing conductive powder such as dust and iron chips, oil mist, salt, or organic solvent, or splashed by cutting chips, dust and cutting oil (water, liquid).
- Do not use in a place where strong electromagnetic noise is generated, strong magnetic field or surge is generated.
- Do not use in a place where static electricity is discharged or in a condition where the product are exposed to electrostatic discharge.
- Do not use in a condition where the product is deformed by force or weight applied.
- Do not use the cylinder close to any objects which are affected by magnets, since magnets are used inside the cylinder.

### 3.3 Piping

#### Caution

- Before connecting piping make sure to clean up chips, cutting oil, dust etc.
- When installing piping or fittings, ensure sealant material does not enter inside the port. When using seal tape, leave 1.5 to 2 threads exposed on the end of the pipe/fitting.
- Tighten fittings to the specified tightening torque.
- Do not use the product outside of the specified ranges for pressure and temperature to prevent equipment damage and malfunction.

## 3 Installation (continued)

- Ensure that the air supply system is filtered to 5 microns.

### 3.4 Lubrication

#### Caution

- SMC products have been lubricated for life at manufacture, and do not require lubrication in service.
- If a lubricant is used in the system, use the equivalent of turbine oil type 1 ISO VG32. Once lubrication is performed, it should be continued since the initial lubricant will flow out causing malfunction.

### 3.5 Sensor unit

#### Caution

- Do not remove the sensor.** The position and sensitivity of the sensor is adjusted correctly. Removing or replacing the sensor may cause malfunction.
- Do not pull the sensor cable with excessive force. Such action may cause detection failure.
- External magnetic field should be 145 mT or less. A strong magnetic field in the close vicinity may cause malfunction since the sensor is a magnetic type sensor. For example, this is equivalent to a magnetic field in a radius of approximately 18 cm from a welding gun using a welding current of about 15000 amperes. When the product is used near strong magnetic fields, take counter measures such as shielding the sensor part with a cover made from a magnetic material.

## 4 Wiring

### 4.1 Preparation for wiring

- Turn OFF the power before wiring (including the insertion and removal of connectors).
- Mount a protective cover over the terminal block after wiring.
- Make sure the power supply has sufficient capacity and voltages are within the specified range before wiring.
- Check the wiring. Incorrect wiring may cause damage or malfunction.

### 4.2 Connector Details

- The table below shows the connector pin layout and wire colours of the CE1 cylinder with connector.

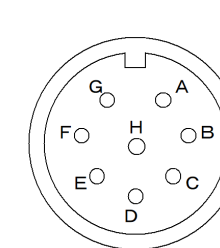

Pin No.	Wire colour	Signal
A	White	A-phase
B	Yellow	B-phase
C	Brown	COM (0V)
D	Blue	COM (0V)
E	Red	12 to 24 VDC
F	Black	0 V
G	Shield	Shield
H	-	Not used

### 4.3 Wiring of Counter

- Use SMC extension cable (Part No. CE1-R\*\*) for wiring between the stroke reading cylinder and the CEU5.

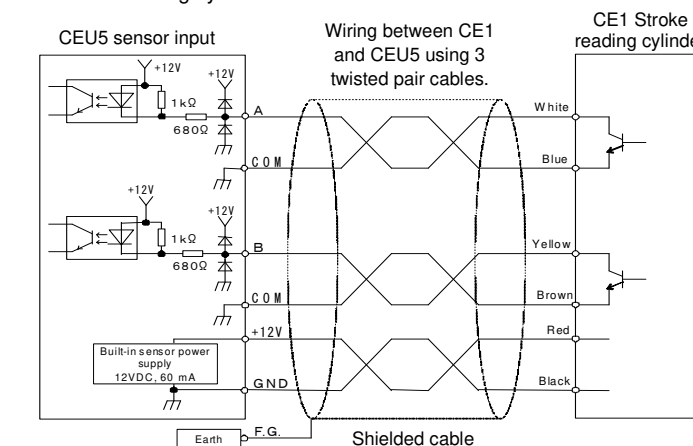

## 4 Wiring (continued)

- If the length of cable between the CE1 and CEU5 is 20 m or longer, use the specified relay box (SMC Part No. CE1-H0374).
- Operation capability is confirmed at max. transfer distance 23 m. Do not use wiring longer than this. (If a longer distance is required use the relay boxes).
- For clamping, care should be taken not to apply excess tension force to the cable connector and sensor connection. If the cable is bent during operation, the bend radius shall be 25 mm or larger.
- Sliding bend performance:  
The number of times the wire can be bent in the conditions shown below before the wire breaks is 4,000,000 times (based on one turn for one time, bend speed 100 times/minute).

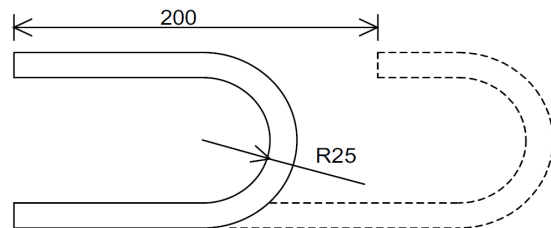

### Caution

Follow the instructions below to prevent malfunction due to noise:

- Use SMC extension cable CE1-R\*\* for CEU1/CEU5.  
Ground the shield wire properly.
- Keep signal wires away from power cables.
- Mount a ferrite core to signal cables to avoid radiated noise effects.
- Use a stable power source for the CE1 power supply.
- Mount a noise filter for possible noise effects of power source.
- Refer to the operation manual for the CEU5 Multi Counter on the SMC website (URL: <https://www.smcworld.com>).
- Separation of signal wires from power wires  
Avoid common or parallel wiring of signal and power wires to prevent malfunction due to noise.

### Wiring arrangement and fixing

Avoid bending cables sharply near the connector or electrical entry in the wiring arrangement.  
Improper arrangement may cause disconnection which in turn may cause malfunction. Fix cables close enough not to avoid excessive force to the connector.

### 4.4 Ground Connection

- Connect the product to ground using the Ground terminal block F.G.
- Individual grounding should be provided close to the product.  
Resistance to ground should be 100 ohms or less.

## 5 Operation Principle

### 5.1 Internal parts of cylinder

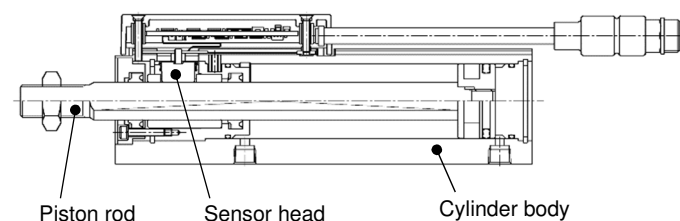

- The piston rod has a magnetic scale on its circumference.
- The detection head of the sensor unit (encoder) is positioned facing the scale. Along the piston rod travel, the sensor detects its magnetic signal. The sensor converts the signal to a pulse output signal. The output signal is measured by the counter.
- In order to maintain the relative position of the scale and the sensor head, an elliptical piston to provide a non-rotating cylinder.

## 5 Operation Principle (continued)

### 5.2 Measurement Principle

The scale cylinder is an air cylinder which has a function to output the piston stroke movement in the form of a pulse signal in 0.1 mm resolution.

Measuring Principle is as follows:

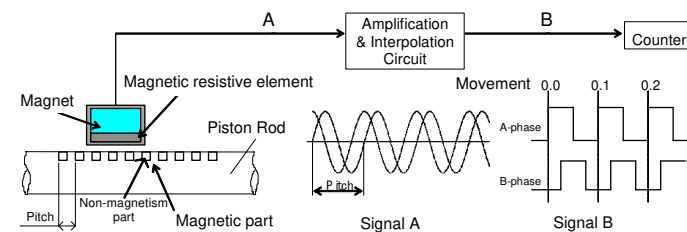

- 1) The piston rod has a scale consisting of a magnetic layer and a non-magnetic layer in a 0.8 mm pitch.
- 2) The magnetic resistive element receives a 2-phase signal (signal A) of sin. and cos. Produced by the piston rod movement. For this waveform, 1 pitch (0.8 mm) is equal to one cycle.
- 3) This signal is amplified and divided into 1/8. As a result, 90° phase difference pulse signal (signal B) is output, which is 0.1 mm per pulse.
- 4) By counting this pulse signal with a counter, with four quadrant multiplier, the piston position can be detected in 0.1 mm resolution.

## 6 How to Order

Refer to the catalogue or operation manual on the SMC website (URL: <https://www.smcworld.com>) for the "How to Order" information.

## 7 Outline Dimensions

Refer to the catalogue or operation manual on the SMC website (URL: <https://www.smcworld.com>) for Outline dimensions.

## 8 Maintenance

### 8.1 General maintenance

#### Caution

- Not following proper maintenance procedures could cause the product to malfunction and lead to equipment damage.
- If handled improperly, compressed air can be dangerous.
- Maintenance of pneumatic systems should be performed only by qualified personnel.
- Before performing maintenance, turn off the power supply and be sure to cut off the supply pressure. Confirm that the air is released to atmosphere.
- After installation and maintenance, apply operating pressure and power to the equipment and perform appropriate functional and leakage tests to make sure the equipment is installed correctly.
- If any electrical connections are disturbed during maintenance, ensure they are reconnected correctly and safety checks are carried out as required to ensure continued compliance with applicable national regulations.
- Do not make any modification to the product.
- Do not disassemble the product, unless required by installation or maintenance instructions.
- **Performing regular maintenance check**  
Check regularly that the product does not operate with failures unsolved. Checks should be carried out by trained and experienced operators.
- **Prohibition of disassembly and modification**  
To prevent accidents such as failures and electric shocks, do not remove the cover to perform disassembly or modification. If the cover must be removed, turn OFF the power before removal.

## 9 Limitations of Use

### 9.1 Limited warranty and disclaimer/compliance requirements

Refer to Handling Precautions for SMC Products.

## 10 Product Disposal

This product shall not be disposed of as municipal waste. Check your local regulations and guidelines to dispose of this product correctly, in order to reduce the impact on human health and the environment.

## 11 Contacts

Refer to [www.smcworld.com](https://www.smcworld.com) or [www.smc.eu](https://www.smc.eu) for your local distributor / importer.

## SMC Corporation

URL : <https://www.smcworld.com> (Global) <https://www.smc.eu> (Europe)  
SMC Corporation, 4-14-1, Sotokanda, Chiyoda-ku, Tokyo 101-0021, Japan  
Specifications are subject to change without prior notice from the manufacturer.  
© 2021 SMC Corporation All Rights Reserved.  
Template DKP50047-F-085M