



ORIGINAL INSTRUCTIONS

Instruction Manual

Smart Positioner - Lever type

Series 52-IP8001 / 52-IP8001-X414

Ex II 1G Ex h ia IIC T4/T5/T6 Ga
 -20°C ≤ Ta ≤ +80°C (T4/T5), -20°C ≤ Ta ≤ +60°C (T6)
 [52-IP8001-X414 = -40°C ≤ Ta ≤ +60°C (T4/T5/T6)]

The intended use of the smart positioner is to accurately control and monitor the position of a pneumatic actuator.

1 Safety Instructions

These safety instructions are intended to prevent hazardous situations and/or equipment damage. These instructions indicate the level of potential hazard with the labels of "Caution," "Warning" or "Danger." They are all important notes for safety and must be followed in addition to International Standards (ISO/IEC) and other safety regulations.

ISO 4414: Pneumatic fluid power - General rules relating to systems.
 ISO 4413: Hydraulic fluid power - General rules relating to systems.
 IEC 60204-1: Safety of machinery - Electrical equipment of machines. (Part 1: General requirements)
 ISO 10218-1: Manipulating industrial robots - Safety, etc.

- Refer to the product catalogue, Operation Manual and Handling Precautions for SMC Products for additional information.
- Keep this manual in a safe place for future reference.

Caution	Caution indicates a hazard with a low level of risk which, if not avoided, could result in minor or moderate injury.
Warning	Warning indicates a hazard with a medium level of risk which, if not avoided, could result in death or serious injury.
Danger	Danger indicates a hazard with a high level of risk which, if not avoided, will result in death or serious injury.

Warning

- Always ensure compliance with relevant safety laws and standards.
- All work must be carried out in a safe manner by a qualified person in compliance with applicable national regulations.

1.1 ATEX Safety Instructions

ATEX Marking Description	
II 1G Ex h ia IIC T4/T5/T6 Ga	
-20°C ≤ Ta ≤ +80°C (T4/T5), -20°C ≤ Ta ≤ +60°C (T6)	
[52-IP8001-X414 = -40°C ≤ Ta ≤ +60°C (T4/T5/T6)]	
Equipment Group II	IIC - For all types of Gas
Category 1	T4/T5/T6 - Temperature classification
G - Gas environment	Ga - EPL
Ex - European standards apply	Ta - Ambient temperature
h ia - Intrinsic Safety	

Based on conformity assessment carried out by DEKRA Certification B.V.

Certificate Number: DEKRA 07ATEX0155 X

If the Certificate number includes an X, special conditions for safe use apply as follows :-

- The Smart Positioner has an aluminium alloy enclosure. When mounted in a potentially explosive atmosphere where the use of category 1 G apparatus is required, it must be installed such that, in the event of rare incidents:
 - An ignition source due to impact or friction is excluded.
 - An ignition source due to electrostatic charging is excluded (for models with a plastic window).
- When using the positioner in a hazardous area ensure that the operational speed of the moving parts is less than 1 m/s, and that the actuator is not hunting.

1 Safety Instructions (continued)

- Take care during normal conditions of use, maintenance and cleaning to avoid danger of ignition due to electrostatic charging. Do not clean with a soft dry cloth.
- Avoid electrostatic charges on the non-metallic parts and coated parts.

1.2 General Safety Instructions

- Protect the product and electrical cables against all impact or mechanical damage.
- If the input current is disconnected during use, the output of OUT1 will become 0 MPa and the output of OUT2 will reach its maximum, regardless of the operating direction (parameter code: 200), whether in direct or reverse actuation.
- If reverse operation is selected (parameter code: 200), when the power supply is turned off, OUT1 output will become 0 MPa and the positioner will start moving toward input current 20 mA DC direction.
- Depending on the parameter settings, the actuator will move erratically when an input current of 4 mA DC is applied.
- There is a capacitor for noise prevention between FG terminal (case) and each input / output terminal of the positioner respectively. Avoid conducting withstand voltage testing or insulation resistance testing between the terminal and case.
- Do not use the product outside of the range of specifications.
- Refer to the Operation manual for further details.

Caution

- Ensure that the air supply system is filtered to 0.3 micron.

2 Specifications

2.1 Specifications

Item	52-IP8001 / 52-IP8001-X414
Input current	4 to 20 mA DC *1 (2 wire system, separate power source not necessary)
Minimum current	3.85 mADC or more
Voltage between terminals	12 VDC (Input resistance equivalent to 600 Ω at 20 mADC)
Max supply power	1 W (100 mADC, 28 VDC) *2
Supply air pressure	0.14 to 0.7 MPa
Standard stroke	10° to 30° *3
Sensitivity	±0.2% F.S. or less *4
Linearity	±1% F.S. or less *4
Hysteresis	0.5% F.S. or less
Repeatability	±0.5% F.S. or less
Temperature coefficient	0.05% F.S. / °C or less
Max output flow rate	80 L / min (ANR) max. (SUP = 0.14 MPa) *5
Air consumption	2 L / min (ANR) or less (SUP = 0.14 MPa) *5 4 L / min (ANR) or less (SUP = 0.4 MPa) *5
Ambient temperature and operating fluid temperature	52-IP8001 = -20°C to 80°C (T4/T5) -20°C to 60°C (T6) 52-IP8001-X414 = -40°C to 60°C (T4/T5/T6)
Explosion Protection Construction	ATEX Intrinsic Safety Type of Protection CE 0344 Ex II 1G Ex h ia IIC T4/T5/T6 Ga
Intrinsically Safe Parameters	Ui=28V, li=100mA, Pi=0.7W, Ci=12.5nF, L1=1.5mH
Degree of Protection	JISF8007 IP65 (conforms to IEC 60529)
Communication protocol	HART Communication
Air connection ports	Rc1/4 female thread (or G1/4 or 1/4NPT)
Electrical connections	M20x1.5 female thread (or G1/2 or 1/2 NPT)
Material	Body / Cover: Die cast aluminium (Coating: Epoxy resin baked) Shaft / Screw: Stainless steel
Weight	Approx. 2.6 kg

2 Specifications (continued)

2.2 Specification of Options

Alarm output 1, 2 *6	
Standard	DIN 19234 / NAMUR
Wiring method	2 wire system
Power supply voltage	5 to 28 VDC
Output current	ON: 2.1 mADC or more, OFF: 1.2 mADC or less
Analogue output *7	
Wiring method	2 wire system
Supply voltage	10 to 28 VDC
Output current	4 to 20 mADC (Min: 3.85 mADC/ Max:24 mADC)
Load resistance	0 to 750 Ω
Accuracy	±0.5% F.S. or less *8

Notes

- *1: 1/2 split range is available using the split range setting (parameter code: 300).
- *2: <Ex.> When applying an input current of 80 mADC, a power supply voltage of 12.5V DC or less can prevent damage to the positioner. Max. supply power = 80 mADC x 12.5 VDC = 1 W
- *3: If the rotating angle of the feedback lever assembled to the positioner is 30° or less, it's stroke can be adjusted optionally in the range from 0 to 10° and from 0 to 30°. Set the operation angle of the feedback lever to 10° when accuracy is required.
- *4: Linearity is a characteristic verified with no load using a factory inspection machine. The positioner cannot function independently and is used as part of a loop including actuating equipment such as valve(s), actuator(s), DCS, etc. Therefore it should be noted that the described characteristic values may vary according to the loop conditions.
- *5: (ANR) indicates standard air in accordance with JIS B0120.
- *6: When no input current has been applied, an alarm is output. Fig. 1 shows an internal alarm circuit.

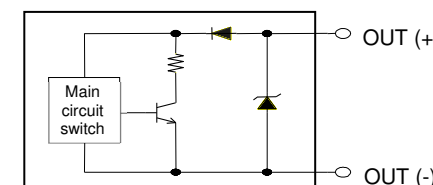
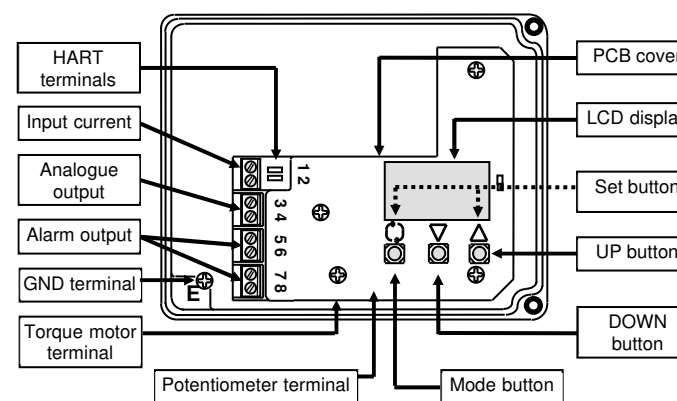

Fig.1

- *7: Connect a load resistance with consideration given to the minimum power supply voltage.
- *8: Analogue output accuracy to position value (P value) in the LCD display.

3 Names of Individual parts

- View of positioner with cover removed.



4 Installation

4.1 Installation

Warning

- Do not install the product unless the safety instructions have been read and understood.
- Protect the product from impact and dropping during installation and when mounted. This may cause product failure.
- Avoid hitting the product with metallic objects.
- Avoid using the product in an environment which can become explosive due to air leakage.
- If the system is in possible danger because of a failure of the positioner, prepare the system with an alternative safety circuit.

4.2 Environment

Warning

- Do not use in an environment where corrosive gases, chemicals, salt water, water or steam are present.
- Do not install in a location subject to vibration or impact in excess of the product specifications. When the positioner is used in locations subject to vibration, use a suitable cable support to prevent lead wire damage.
- Do not mount in a location exposed to radiant heat that would result in temperatures in excess of the product specifications.
- Do not mount the positioner in a location with high humidity and temperature.
- Do not expose to direct sunlight (UV light). Install a suitable protective cover for protection against the effects of direct UV light.
- Do not mount the product near a source of electrical noise.

4.3 Piping

Caution

- Before connecting piping make sure to clean up chips, cutting oil, dust etc.
- When installing piping or fittings, ensure sealant material does not enter inside the port. When using seal tape, leave 1.5 to 2 threads exposed on the end of the pipe / fitting.
- Use de-humidified and dust free clean air as the air supply source.

- The Positioner has very fine internal paths. Therefore use dehydrated and filtered clean air, and avoid using lubricant. Use a cleaning system according to No. 4 or higher from the "Compressed Air Cleaning Equipment" listed in the manual for air-supply cleaning systems.
- Avoid using compressed air containing chemicals, synthetic fluid including organic solvent, salinity, and corrosive gas as it may cause malfunction.

Piping Layout

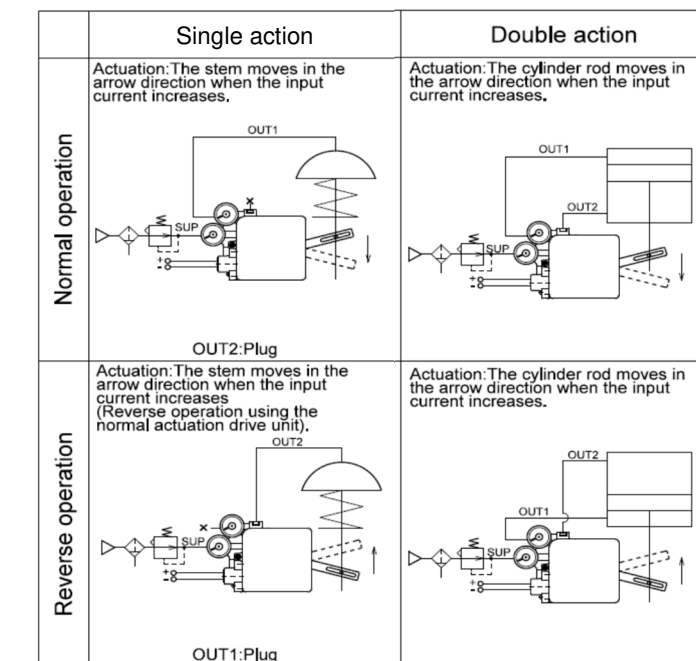

4 Installation (continued)

4.4 Lubrication

Caution

- The positioner has a fixed orifice and nozzle, which contain fine internal paths. Use filtered, dehydrated air and avoid the use of lubricants as this may cause malfunction of the positioner. Ensure that the air supply system is filtered to 0.3 micron.

4.5 Handling

- Avoid applying impact to the body and torque motor of the positioner and avoid excessive force to the armature because it may lead to failure. Handle with care during transportation and operation.
- If the positioner is left unused at the operation site for an extended period, ensure the body cover unit is fitted, and mount a plug on the wiring and piping ports. If the atmosphere is of high temperature or high humidity, take measures to avoid condensation inside the positioner. Condensation control measures must be taken thoroughly during export shipment.
- Be sure to mount the body cover unit when using the positioner. IP65 cannot be guaranteed if the mounting condition of the body cover is incorrect. To achieve the IP rating tighten the cover fixing screws using the appropriate torque (2.8 to 3.0 Nm).

4.6 Mounting

Warning

- Check that the positioner is securely mounted on to the actuator.
- Be careful not to get fingers caught when aligning the mounting positions.
- Allow sufficient space around the positioner for maintenance and adjustment during installation.
- Disconnect the supply pressure and ensure compressed air is discharged from the positioner and actuator completely before mounting.

Examples of Mounting on Actuator

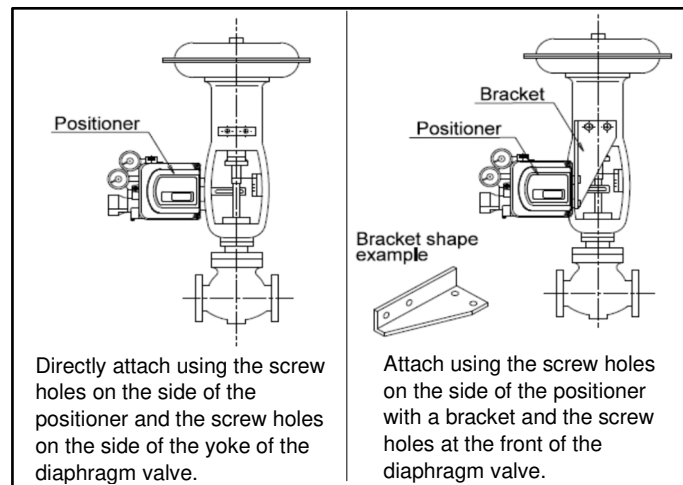

Connection of Feedback Lever

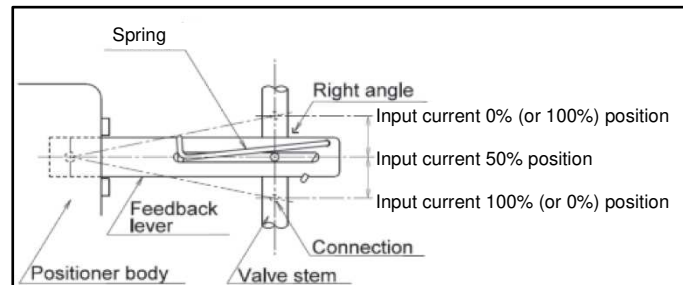

- Attach the positioner so that the valve stem and feedback lever form a right angle when the input current is at 50% (distribute evenly with 50% input current set as a reference).
- Attach the positioner so that the operation angle of the feedback lever is within the range of 10° to 30°.

4 Installation (continued)

- Do not impact the feedback shaft of the positioner when the feedback lever is connected with the valve stem or installed on the positioner.
- There are 3 types of feedback lever unit for different stroke applications.

Stroke	Lever Part No.
10 to 85 mm (standard)	P565010-323
35 to 100 mm	P565010-324
50 to 140 mm	P565010-325

For further details of the feedback lever specifications refer to the operation manual on the SMC website (URL: <http://www.smcworld.com>).

4.7 Electrical wiring

Caution

- Be sure to perform electrical wiring with the input current turned OFF.
- Use a ground connection and perform electrical installation following relevant local regulations, to prevent noise from disturbing the input current and static electricity from damaging the positioner.
- Do not touch around the actuator axis when applying an input current after wiring.
- Use an input current source (4 to 20 mA DC) with a secure 12 V DC or greater voltage as close as possible to the input current terminal to avoid voltage drops.
- An M20 x 1.5 blue explosion proof cable gland is provided for electrical connection (code M) approved to ATEX II 2GD. It has been subsequently tested by the notified body in accordance with ATEX II 1GD during certification of the positioner.

Warning

- To use in an explosion protection specification the positioner may only be connected to a certified intrinsically safe electrical circuit with the maximum parameter given in the specifications.
- Intrinsically Safe barriers used in the positioner supply circuit must be linear resistive output type barriers, in accordance with the I.S. parameters given in the specifications.

Wiring layout (including output functions)

- Remove the positioner body cover.
 - Connect the input current wiring from a meter (controller) and the optional output wiring as shown below. The M20x1.5 input port is fitted with a blue cable gland.
- Note 1) If the electrical connections are G1/2 or 1/2NPT option the cable gland will not be supplied.
- Note 2) Be sure to fit a plug to any unused electrical ports.

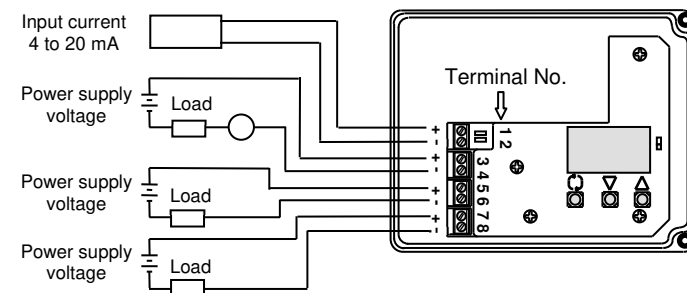

Terminal No.	Description	Wire diameter	Remarks
1	4 to 20 mA input current	0.14 to 1.5 mm ² stranded wire (AWG26-14).	Minimum input current required for operation = 3.85 mA
2			
3	Analogue output		Output range: 3.85 to 24 mA
4	Alarm output 1		
5	Alarm output 2		
6	Alarm output 1		
7	Alarm output 2		
8	Alarm output 2		

For further details of intrinsically safe wiring, analogue output and alarm output specifications refer to the operation manual on the SMC website (URL: <https://www.smcworld.com>).

5 Settings

The work flow from set-up to initial adjustment of the positioner is shown below. Follow this flow when performing set up and adjustment. For further details refer to the operation manual on the SMC website (URL: <https://www.smcworld.com>).

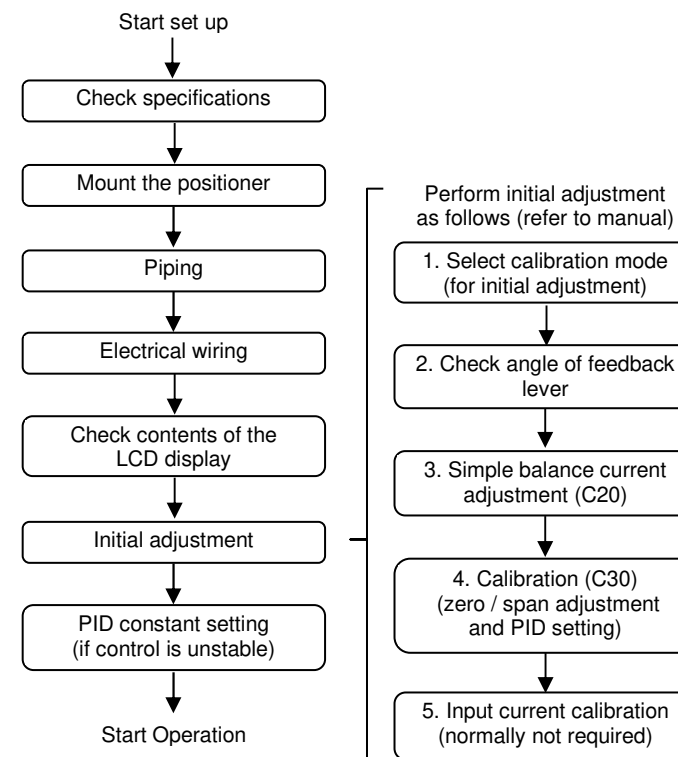

6 How to Order

Refer to the catalogue or operation manual on the SMC website (URL: <https://www.smcworld.com>) for "How to Order" details.

7 Outline Dimensions (mm)

Refer to the catalogue or operation manual on the SMC website (URL: <https://www.smcworld.com>) for Outline dimensions.

8 Maintenance

8.1 General Maintenance

Caution

- Not following proper maintenance procedures could cause the product to malfunction and lead to equipment damage.
- If handled improperly, compressed air can be dangerous.
- Maintenance of pneumatic systems should be performed only by qualified personnel.
- Before performing maintenance, turn off the power supply and be sure to cut off the supply pressure. Confirm that the air is released to atmosphere.
- After installation and maintenance, apply operating pressure and power to the equipment and perform appropriate functional and leakage tests to make sure the equipment is installed correctly.
- If any electrical connections are disturbed during maintenance, ensure they are reconnected correctly and safety checks are carried out as required to ensure continued compliance with applicable national regulations.
- Do not make any modification to the product.
- Do not disassemble the product. A product which has been disassembled cannot be guaranteed. Consult with SMC.

8 Maintenance (continued)

- Modification of the electrical construction is prohibited to maintain the ATEX explosion proof certification.
- Check the positioner once a year. If excessively worn diaphragms, O-rings or seals are found, or any unit has been damaged, replace with new units. Treatment at an early stage is especially important if the positioner is used in a place of severe environment like coastal areas.
- If the fixed orifice is clogged with carbon particles or others, remove the pilot valve unit Auto/Manual switch screw (built-in fixed orifice) and clean it by inserting a φ0.2 wire into the aperture. If it must be replaced with new one, stop the supply pressure and remove the stopper screw of the pilot valve unit.
- It is recommended to replace the pilot valve unit every 3 years. When the pilot valve unit is disassembled, apply a small amount of specified grease to the sliding surface.
- Check for air leaks from the compressed air piping. Air leaks could lower the performance characteristics of the positioner. Air is normally discharged from a bleed port, but this is a necessary air consumption based on the construction of the positioner, and is not an abnormality if the air consumption is within the specified range.
- When replacing piping to change the positioner operating direction be sure to perform a span adjustment (parameter C70).
- When removing the positioner from the actuator and mounting it onto another actuator, malfunction may occur due to retained initial constants. Therefore connect the input current with the air supply disconnected, and select parameter mode for adjustments.
- The balance current will change depending on the positioner orientation. Adjust the balance current (parameter C60) each time the orientation is changed.

9 Limitations of Use

9.1 Limited warranty and Disclaimer/Compliance Requirements

Refer to Handling Precautions for SMC Products.

Warning

Do not exceed any of the product specifications.

10 Product disposal

This product should not be disposed of as municipal waste. Check your local regulations and guidelines to dispose of this product correctly, in order to reduce the impact on human health and the environment.

11 Contacts

Refer to www.smcworld.com or www.smc.eu for your local distributor/importer.

SMC Corporation

URL : <http://www.smcworld.com> (Global) <http://www.smc.eu> (Europe)
 SMC Corporation, Akihabara UDX15F, 4-14-1, Sotokanda, Chiyoda-ku, Tokyo 101 0021
 Specifications are subject to change without prior notice from the manufacturer.
 © 2021 SMC Corporation All Rights Reserved.
 Template DKP50047-F-085L