



MHM

Magnetic Gripper

Kit

User Manual

For Universal Robots
Document Version 1.1
March 2019



Contents

General Information	3
Welcome	3
What's Included	3
Getting Started.....	4
Mounting Overview	4
Mounting Instructions	4
SMC User Interface Guide.....	5
Construction Drawings.....	8
Replacement Parts	8
Technical Details	9
MHM Series, Magnetic Gripper	9
SY Series, Solenoid Valve (Rubber Seal).....	10

Visit www.smcusa.com/ur for more information.

For questions, contact marketing@smcusa.com



General Information

Welcome

Thank you for choosing SMC. The UR+ Certified MHM Magnetic Gripper Kit offers an easy Plug + Play integration solution for transferring ferromagnetic workpieces that are of uneven surface, porous, or susceptible to damage when traditional methods of vacuum systems or mechanical grippers are not viable solutions.

From Startups to experienced integrators, SMC has the global support to equip your UR e-series cobots with a solution complete with URcap plugin.

What's Included

The MHM Magnetic Gripper Kit includes everything needed to mount and setup to UR Robot.



Figure 1:
(1) Transition Plate
(4) M6x10L SHCS



Figure 2:
(1) Gripper Assembly with 8 pin connector
(4) M6x20L SHCS
*One M6x20L is already installed in the Gripper Assembly

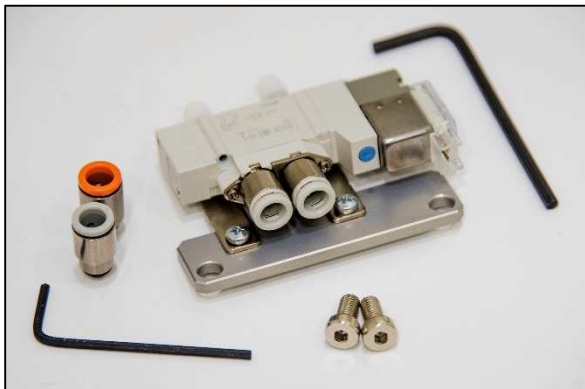

Figure 3:
(1) Valve Assembly
(2) M5x10L SHCS
Hexagon Wrench

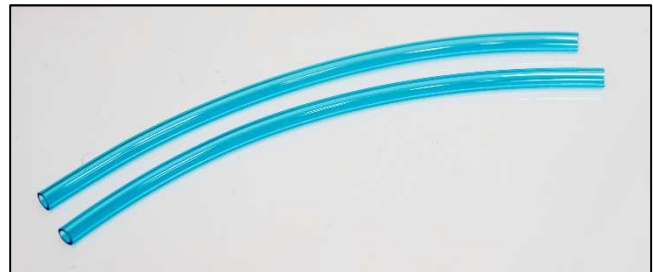

Figure 4:
(2) 6mm tubing

Note: URcap available for download from www.smcusa.com/ur



Getting Started

Mounting Overview

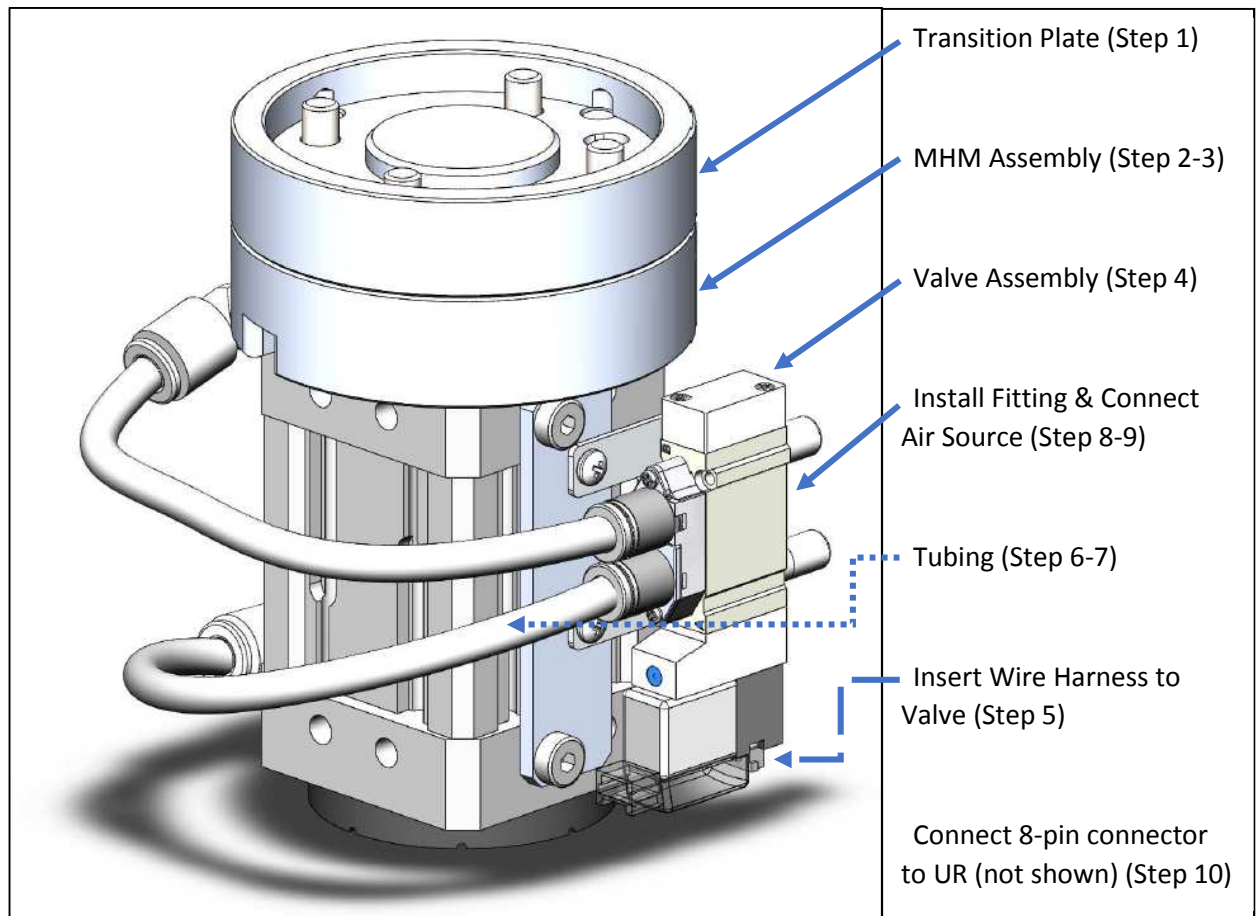

Mounting Instructions

- 1) Attach the transition plate to the robot using the (4) M6x10L SHCS.
- 2) Align the gripper assembly to the transition plate with the 8-pin connector on the same side as the connection to the robot.
- 3) Attach the gripper assembly by using the (4) M6x20L SHCS.
- 4) Attach the valve assembly to the gripper assembly in the mounting holes opposite the fittings by using the (2) M5x10L SHCS.
- 5) Attach the wire harness to the valve.
- 6) Attach one piece of tubing between the elbow fitting closest to the robot and the fitting on the valve closest to the robot arm.
- 7) Attach one piece of tubing between the elbow fitting closest to the bumper and the fitting on the valve closest to the electrical connection.
- 8) Install fitting for air supply source to valve
 - a. If you are using $\frac{1}{4}$ " tubing as air source, install the fitting KQ2S07-32N (orange cap) to the valve between the two white silencers.
 - b. If you are using 6mm tubing as air source, install the fitting with the KQ2S06-M5N (grey cap) to the valve between the two white silencers. There is an internal hex to use for installation.
- 9) Attach the air supply source to fitting inserted from Step 8.
- 10) Attach the 8-pin connector to the UR unit



SMC User Interface Guide

Downloading the URCap

Visit www.smcusa.com/ur page and find the “URCap Download” button to download the file “URCap.zip”. Save the “.urcap” file to a local USB to install the URCap on the robot.

On the teach pad, Navigate to the Settings Tab and open the System node and last select URCaps, see below.

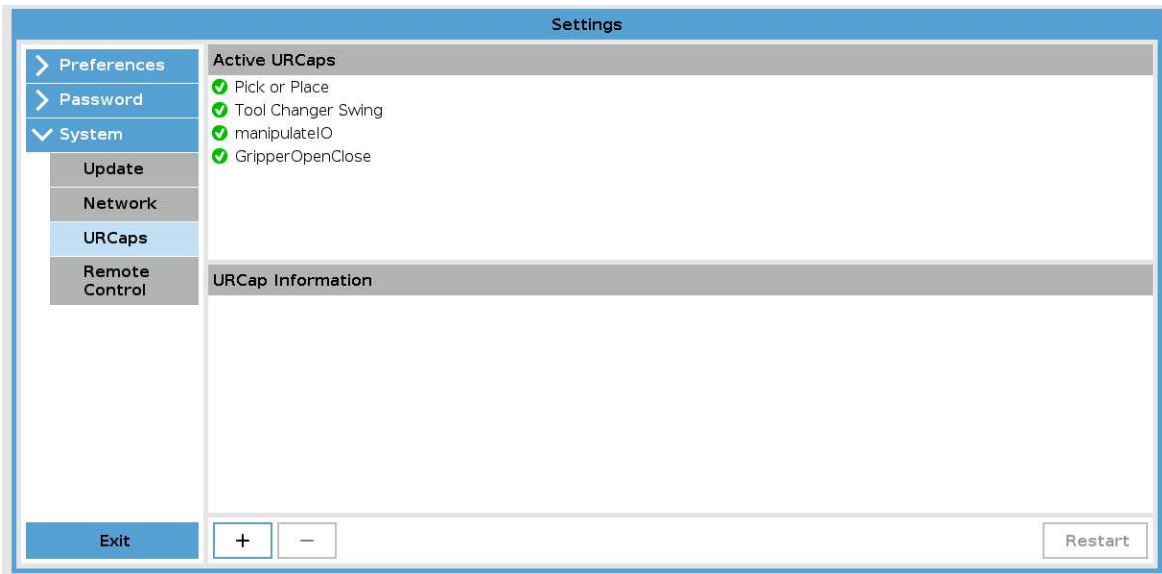

Select the “+” button to add a URCap then browse the the .urcap file. After adding the .urcap file a restart is required.

Installation Settings

By navigating to the Installation tab set the “Tool Output Voltage” to 24V.

Next, set “Digital Output 0” and “Digital Output 1” to Sourcing(PNP)

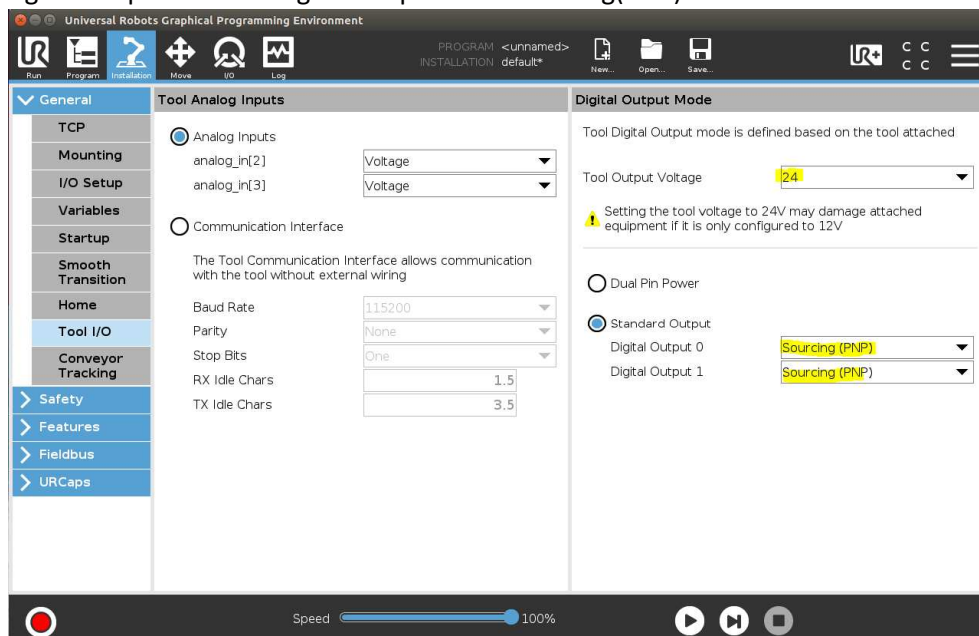



Operating the SMC MHM Gripper Node

The SMC MHM URCap is a simple operation with 2 options, Grip and Release. Example shown below.

SMC MHM Gripper Node

Select which operation you wish to perform at this node:

Grip

Release

Only one option can be selected at a time with each node. Multiple instances of the node can be implemented into the program.

Grip will move the piston and magnet toward the workpiece. By changing "Digital Out 0" to HIGH

Release will move the piston and magnet to the release position. By setting "Digital Out 0" to LOW.

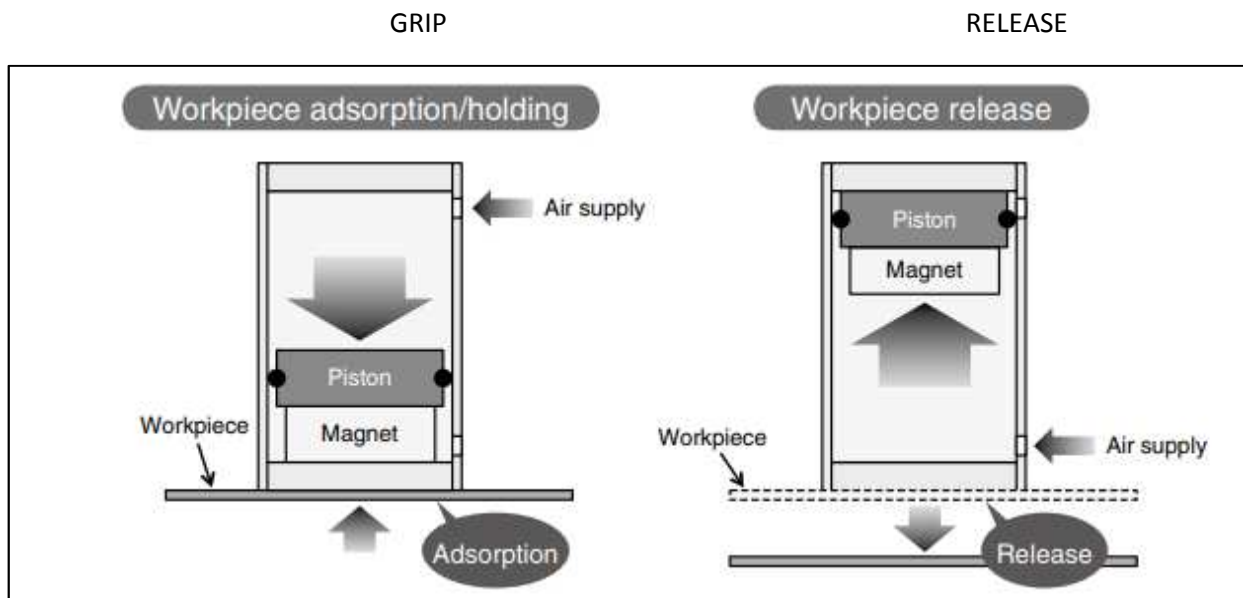



To confirm the position of the cylinder before continuing the program. Implement the “Wait” node into the program.

Release position will be confirmed when “Tool_In[0]” is High. Example below.

Close position will be confirmed when “Tool_In[1]” is High

Wait
Please select what should trigger the robot's next action;

No Wait

Wait seconds

Wait for Digital Input

Wait for mA

Wait for



Construction Drawings

All measurements are in millimeters (mm). For simplicity, the auto switch harnesses are not shown.

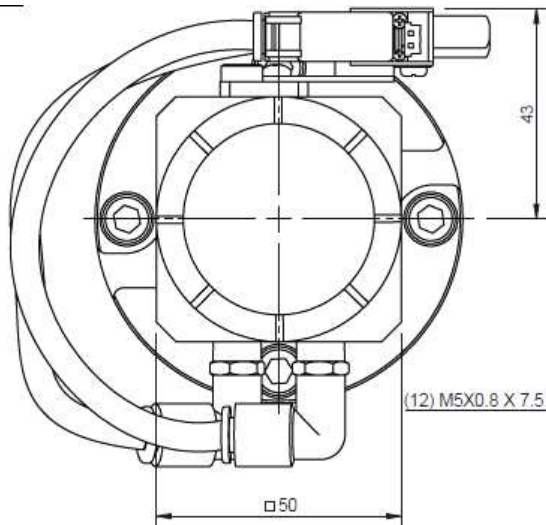

Bottom View

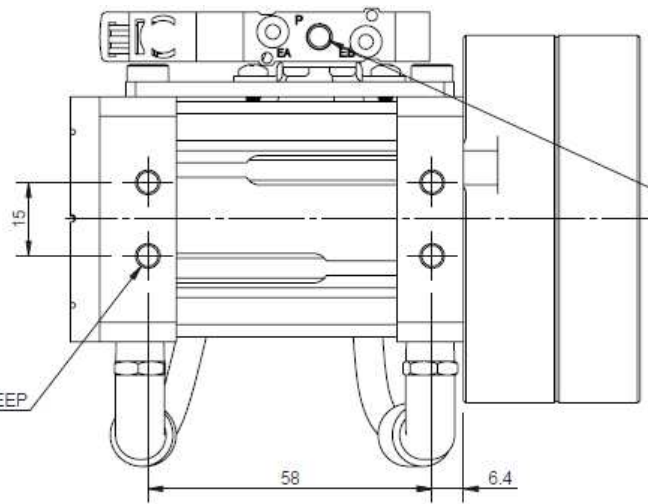

Side View

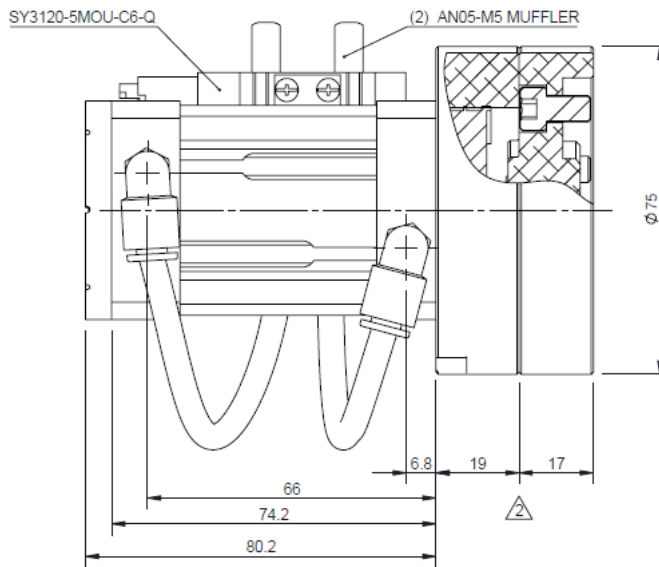

Side View

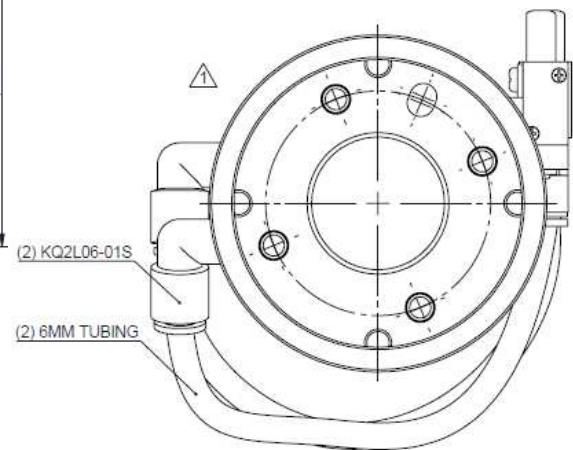

Top View

Replacement Parts

Replacement		Bumper Replacement (80N included in assembly)	
Valve	SY3120-5MOU-C6-Q	Holding Force 80N	MHM-A3201-1-X6400
Silencer	AN05-M5	Holding Force 50N	MHM-A3201-2-X6400
Fitting (attached to MHM)	KQ2L06-01S	Holding Force 30N	MHM-A3201-3-X6400
Fitting (attached to 1/4" air supply)	KQ2S07-32N (orange cap)		
Fitting (attached to 6mm air supply)	KQ2S06-M5N (grey cap)		



Technical Details

MHM Series, Magnetic Gripper

Please refer to www.smcusa.com for additional information and complete precautions.

Specifications

Action	Double acting	
Fluid	Air	
Operating pressure	0.25 to 0.6 MPa	
Ambient and fluid temperature	-10 to 60°C (No freezing)	
Holding force	MHM-32D1-X6400	80 N
(Workpiece thickness: 0.6 mm)	MHM-32D2-X6400	50 N
	MHM-32D3-X6400	30 N
Residual holding force	0.3 N or less	
Lubrication	Non-lube	
Weight	475 g	

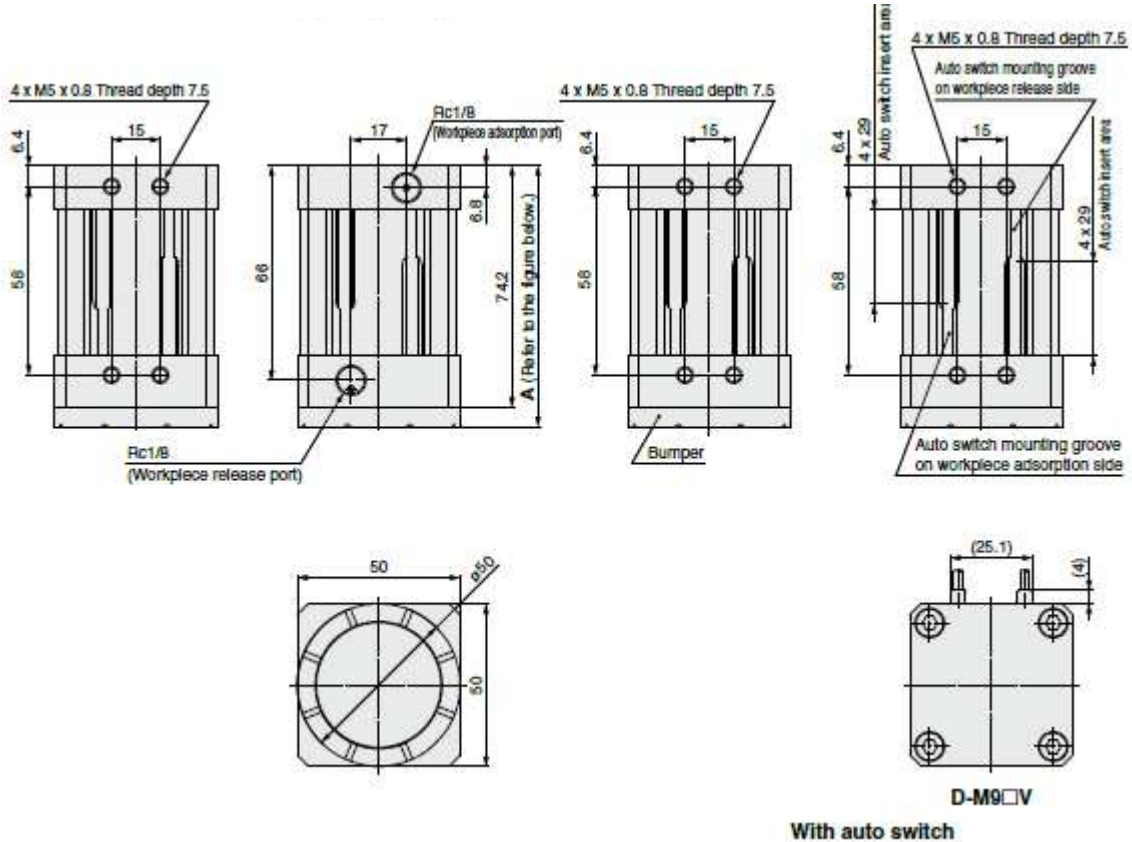

⚠ Caution

- Since a thin plate is used for the metal surface on the end, damage may occur when an impact load is applied due to contact with a workpiece. Be sure to attach a bumper before use, and check and adjust operation so that no impact load is applied to the metal surface.
- When operating an actuator with a small diameter and a short stroke at a high frequency, dew condensation (water droplets) may occur inside the piping depending on the conditions.
Simply connecting the moisture control tube (IDK series) to the actuator will prevent dew condensation from occurring. For details, refer to the IDK series in the **WEB catalog**.



SY Series, Solenoid Valve (Rubber Seal)

Please refer to www.smcusa.com for additional information and complete precautions

Valve Specifications

Valve type		Rubber seal	Metal seal	
Fluid				
		Air		
Internal pilot operating pressure range [MPa]	2-position single	0.15 to 0.7	0.1 to 0.7 (High pressure type: 0.1 to 1)	
	2-position double	0.1 to 0.7		
	3-position	0.2 to 0.7		
	4-position dual 3-port valve	0.15 to 0.7	—	
External pilot operating pressure range [MPa]	Operating pressure range		-100 kPa to 0.7 (4-position: -100 kPa to 0.6) -100 kPa to 0.7 (High pressure type: -100 kPa to 1)	
	Pilot pressure range	2-position single	0.25 to 0.7	0.1 to 0.7 (High pressure type: 0.1 to 1)
		2-position double		
		3-position		
	4-position dual 3-port valve	Operating pressure + 0.1 or more (Min. 0.25) to 0.7	—	
Ambient and fluid temperature [°C]		-10 to 50 (No freezing)		
Max. operating frequency [Hz]	SY3000 SY5000	2-position single/double	5	20*1
		4-position dual 3-port valve	3	10*1
		3-position		
	SY7000	2-position single/double	5	10*1
		4-position dual 3-port valve	3	—
		3-position	3	10*1
Manual override		Non-locking push type Push-turn locking slotted type Push-turn locking lever type Slide locking type		
Pilot exhaust type	Internal pilot	Main/Pilot valve common exhaust	Main/Pilot valve individual exhaust	
	External pilot	Pilot valve individual exhaust		
Lubrication		Not required		
Mounting orientation^{a2}		Unrestricted	Single: Unrestricted Double/3-position: Main valve is horizontal.	
Impact/Vibration resistance^{a2} [m/s²]		150/30		
Enclosure		IP67 (Based on IEC60529) ^{a3}		
Coil rated voltage [DC]		24, 12 V		
Allowable voltage fluctuation [V]		±10% of rated voltage ^{a4}		
Power consumption [W]	Standard	0.35 (With indicator light: 0.4)		
	High pressure type, Quick response type	0.9 (With indicator light: 0.95)		
	With power saving circuit	Standard: 0.1 ^{a5} (With indicator light only) [Inrush 0.4, Holding 0.1], High pressure type: 0.4 ^{a5} (With indicator light only) [Inrush 0.95, Holding 0.4]		
Surge voltage suppressor		Diode (Varistor for non-polar type)		
Indicator light		LED		

*1: Use below 5 Hz for with the power saving circuit.

*2: Impact resistance: No malfunction occurred when it is tested in the axial direction and at the right angles to the main valve and armature in both energized and de-energized states every once for each condition. (Values at the initial period)

Vibration resistance: No malfunction occurred in a one-sweep test between 45 and 2000 Hz. Test was performed at both energized and de-energized states in the axial direction and at the right angles to the main valve and armature. (Values at the initial period)

Refer to page 394 for the fixation of DIN rail mounting type manifold.

*3: In the case of a metal seal, there are restrictions in the operating environment. Refer to the Specific Product Precautions (page 389).

*4: Due to voltage drops by the internal circuit in S/Z type and T type (with power saving circuit), use within the allowable voltage fluctuation as follows.

S/Z type { 24 VDC: -7% to +10% T type { 24 VDC: -8% to +10%
 { 12 VDC: -4% to +10% { 12 VDC: -6% to +10%

*5: For details, refer to page 391.

Environment

Warning

- Do not use valves in atmospheres of corrosive gases, chemicals, sea water, water, water vapor, or where there is direct contact with any of these.
- Products compliant with IP67 enclosures (based on IEC60529) are protected against dust and water, however, these products cannot be used in water. If using in an environment that is exposed to water and dust splashes, take measures such as using a protective cover.
- When using built-in silencer type manifold with an IP67 enclosure, keep the exhaust port of the silencer from coming in direct contact with water or other liquids.
- The metal seal valve is provided with a hole to discharge the pilot EXH. When using in atmospheres containing water and dust, mount it horizontally.

Manual Override

Warning

Regardless of an electric signal for the valve, the manual override is used for switching the main valve. Connected actuator is started by manual operation. Use the manual override after confirming that there is no danger.

Non-locking push type

Push down on the manual override button until it stops.

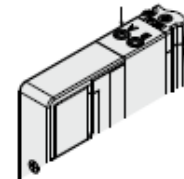

Continuous Duty

Caution

If a valve is energized continuously for a long period of time, the rise in temperature due to heat-up of the coil assembly may cause a decline in solenoid valve performance, reduce service life, or have adverse effects on peripheral equipment. If the valve is energized continuously for a long period of time, be sure to use a valve with power saving circuit. In particular, if three or more adjacent stations on the manifold are energized simultaneously for extended periods of time or if the valves on A side and B side are energized simultaneously for a long period of time, take special care as the temperature rise will be greater.



Global Manufacturing, Distribution and Service Network

Worldwide Subsidiaries

EUROPE

AUSTRIA
SMC Pneumatik GmbH (Austria)

BELGIUM
SMC Pneumatics N.V./S.A.

BULGARIA
SMC Industrial Automation Bulgaria EOOD

CROATIA
SMC Industrijska Automatika d.o.o.

CZECH
SMC Industrial Automation CZ s.r.o.

DENMARK
SMC Pneumatik A/S

ESTONIA
SMC Pneumatics Estonia

FINLAND
SMC Pneumatics Finland OY

FRANCE
SMC Pneumatique S.A.

GERMANY
SMC Pneumatik GmbH

GREECE
SMC Hellas EPE

HUNGARY
SMC Hungary Ipari Automatizálási Kft.

IRELAND
SMC Pneumatics (Ireland) Ltd.

ITALY
SMC Italia S.p.A.

LATVIA
SMC Pneumatics Latvia SIA

LITHUANIA
SMC Pneumatics Lietuva, UAB

NETHERLANDS
SMC Pneumatics BV

NORWAY
SMC Pneumatics Norway A/S

POLAND
SMC Industrial Automation Polska Sp.z.o.o.

ROMANIA
SMC Romania S.r.l.

RUSSIA
SMC Pneumatik LLC.

SLOVAKIA
SMC Priemysel'ná Automatizácia, s.r.o.

SLOVENIA
SMC Industrijska Avtomatika d.o.o.

SPAIN / PORTUGAL
SMC España, S.A.

SWEDEN
SMC Pneumatics Sweden AB

SWITZERLAND
SMC Pneumatik AG

UK
SMC Pneumatics (U.K.) Ltd.

ASIA

CHINA
SMC (China) Co., Ltd.

HONG KONG
SMC Pneumatics (Hong kong) Ltd.

INDIA
SMC Pneumatics (India) Pvt. Ltd.

JAPAN
SMC Corporation

MALAYSIA
SMC Pneumatics (S.E.A.) Sdn. Bhd.

PHILIPPINES
SMC Pneumatics (Philippines), Inc.

SINGAPORE
SMC Pneumatics (S.E.A.) Pte. Ltd.

SOUTH KOREA
SMC Pneumatics Korea Co., Ltd.

TAIWAN
SMC Pneumatics (Taiwan) Co., Ltd.

THAILAND
SMC Thailand Ltd.

NORTH AMERICA

CANADA
SMC Pneumatics (Canada) Ltd.

MEXICO
SMC Corporation (Mexico) S.A. DE C.V.

USA
SMC Corporation of America

SOUTH AMERICA

ARGENTINA
SMC Argentina S.A.

BOLIVIA
SMC Pneumatics Bolivia S.R.L.

BRAZIL
SMC Pneumaticos do Brazil Ltda.

CHILE
SMC Pneumatics (Chile) S.A.

PERU
SMC Corporation Peru S.A.C.

VENEZUELA
SMC Neumatica Venezuela S.A.

OCEANIA

AUSTRALIA
SMC Pneumatics (Australia) Pty. Ltd.

NEW ZEALAND
SMC Pneumatics (N.Z.) Ltd.

U.S. & Canadian Sales Offices

WEST

Austin
Dallas
Los Angeles
Phoenix
Portland
San Jose

CENTRAL

Chicago
Cincinnati
Cleveland
Detroit
Des Moines
Grand Rapid
Indianapolis
Kansas
Milwaukee
Minneapolis
St. Louis

EAST

Albany
Atlanta
Boston
Charlotte
Nashville
New Jersey
Rochester
Tampa

CANADA

Vancouver
Toronto
Windsor
Montreal

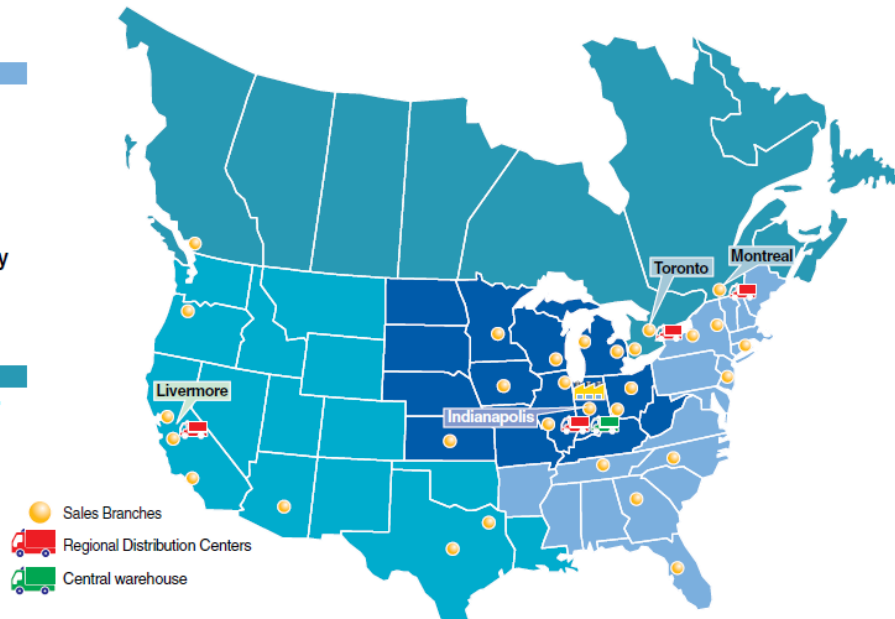

SMC Corporation of America
10100 SMC Blvd., Noblesville, IN 46060
www.smcusa.com

SMC Pneumatics (Canada) Ltd.
www.smc Pneumatics.ca

(800) SMC.SMC1 (762-7621)
e-mail: sales@smcusa.com
International inquiries: www.smcworld.com

