

Reduction of the turning diameter required by mounting the air grippers in parallel

Double Gripper Reversing Unit

- 3-Finger Air Grippers in parallel. Since the turning radius has been reduced, this can be mounted in limited spaces.

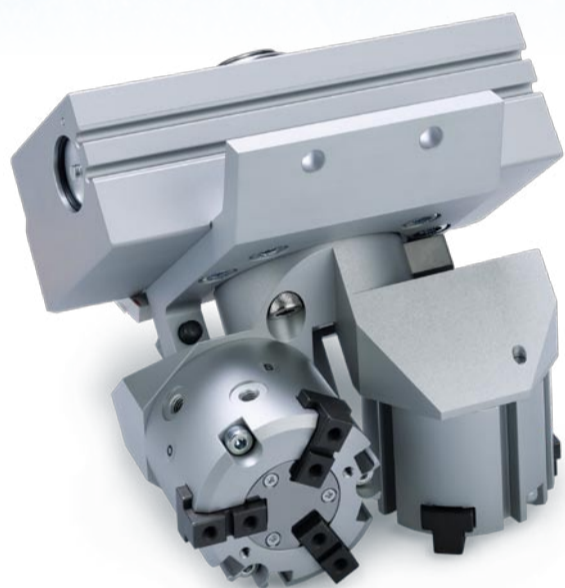

Double gripper reversing unit

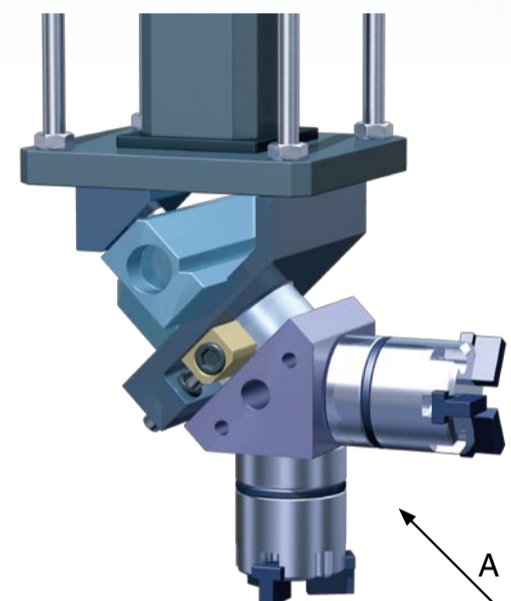
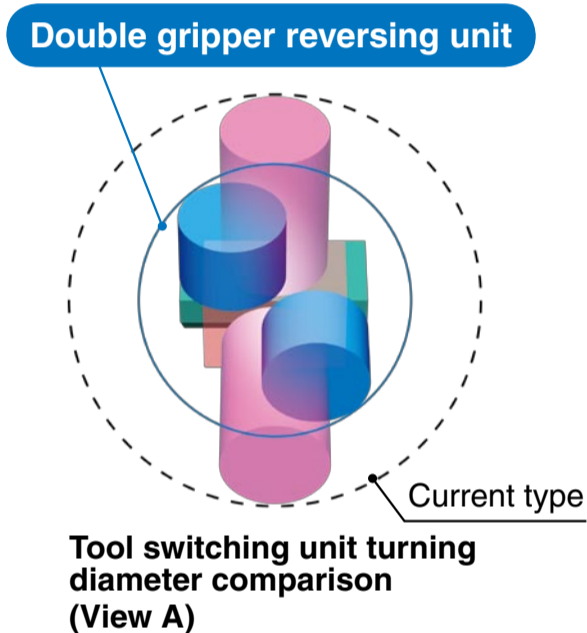

Current type

- The stroke of the equipment shutters can be reduced.

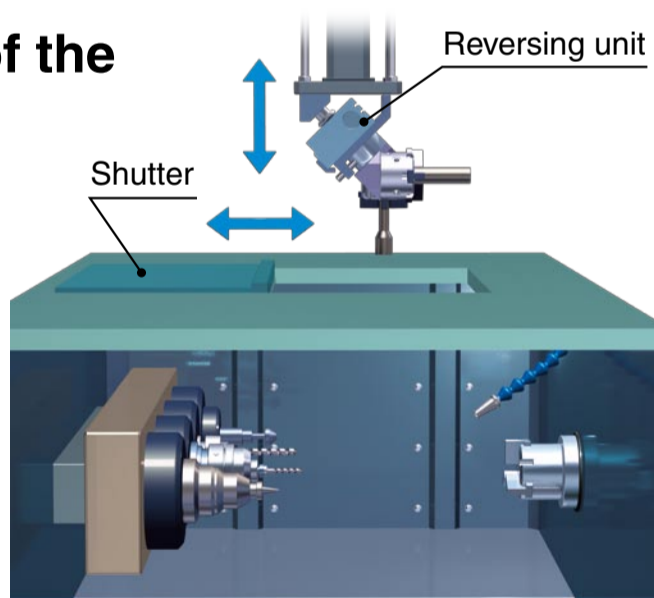

- Cylinder size: $\varnothing 32$

- External gripping force: 74 N
- Internal gripping force: 82 N
(0.5 MPa, L = 30 mm)

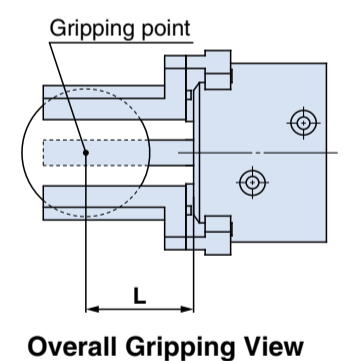

- Finger stroke: 8 mm

- Seal material: Fluororubber

Application Examples

- **Switching Loaders for Machining Equipment**
Turning Diameter can be reduced.

